

INSTRUCTION MANUAL

for

AEL MODEL FM-15QE

FM EXCITER

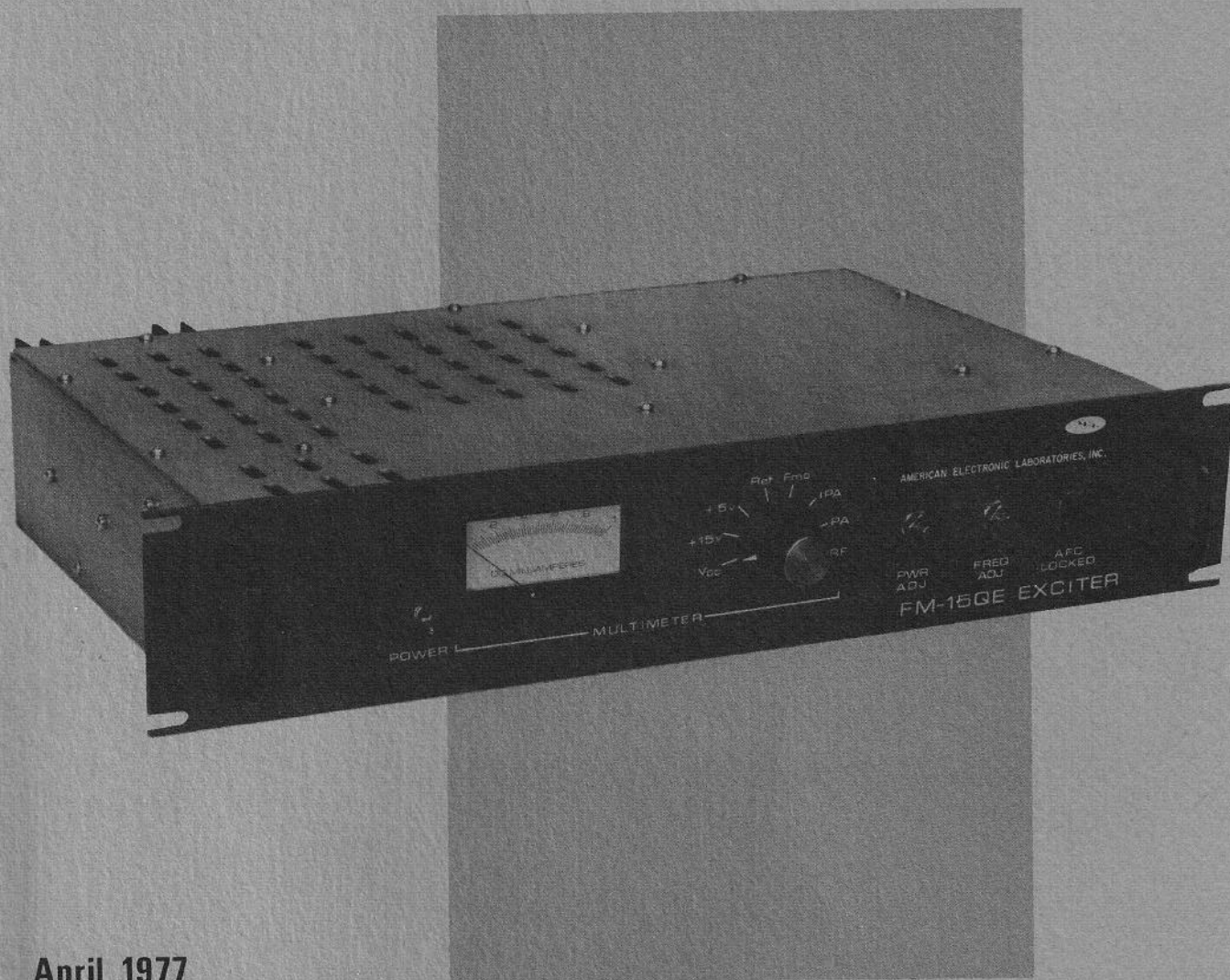

April 1977



American Electronic Laboratories, Inc.

A Subsidiary of AEL Industries, Inc.

Richardson Road, Colmar, PA 18915

INSTRUCTION MANUAL

FOR

AEL MODEL

FM-15QE

FM EXCITER

May 1977



AMERICAN ELECTRONIC LABORATORIES, INC.

A DIVISION of AEL INDUSTRIES, INC.

Richardson Road

Colmar, PA 18915

MODEL _____

DATE _____

SERIAL NO. _____

TO: _____

WARRANTY

Seller warrants the products of this contract, manufactured and sold by Seller, against failure due to defects in material and workmanship under normal use and service for a period of _____ from the date of original delivery when operated in accordance with Seller's operating instructions. This warranty shall not apply to tubes, fuses, bulbs, semiconductors, motors, meters and relays; however, the warranties extended by the original manufacturers apply. All warranties whether expressed or implied (hereinafter collectively called "warranties") shall extend only to the Buyer and no others.

Warranties are valid only when and if (a) Seller receives prompt written notice of the breach within the period of the warranty, (b) the defective product is properly packed and returned by the Buyer (transportation and insurance prepaid), and (c) Seller determines, in its sole judgment, that the product is defective and not subject to any misuse, neglect, improper installation, negligence, accident, or (unless authorized in writing by Seller) repair or alteration. Seller's exclusive obligation under all warranties, and Seller's exclusive liability for any personal and/or property damages (including direct, consequential or incidental) caused by the breach of any or all warranties, shall be limited to the following: (a) repairing or replacing (in Seller's sole discretion) any defective parts free of charge (f.o.b. Seller's plant), and/or (b) crediting (in Seller's sole discretion) all or a portion of the purchase price to the Buyer.

SELLER DOES NOT WARRANT MERCHANTABILITY OF GOODS OR PARTS THEREOF NOT MANUFACTURED BY SELLER THERE ARE NO WARRANTIES THAT EXTEND BEYOND THE DESCRIPTION ON THE FACE HEREOF OR BEYOND THE TERMS AND CONDITIONS CONTAINED HEREIN.

GUARANTEE

American Electronic Laboratories, Inc. also agrees to make available for purchase by Buyer the replaceable parts for the transmitters and exciters, and stereo generators sold hereunder for a period of ten (10) years at the price charged by AEL to others for said parts.

Table of Contents

<u>Section</u>		<u>Page</u>
I	GENERAL DESCRIPTION	
	1-1. Introduction	1-1
	1-2. Physical Description	1-1
	1-3. Electrical Description	1-1
	1-4. Specifications	1-1
II	INSTALLATION	
	2-1. Unpacking and Inspection	2-1
	2-2. Mechanical Installation	2-1
	2-3. Environmental Requirements	2-1
	2-4. Mounting Requirements	2-1
	2-5. Electrical Installation	2-1
	2-6. AC Power	2-1
	2-7. Low Output Power Operation	2-1
	2-8. Monaural Transmission	2-3
	2-9. Stereo Transmission	2-3
	2-10. SCA Transmission	2-3
	2-11. External Meter	2-3
	2-12. RF Output	2-3
	2-13. Installation Checkout	2-3
III	OPERATION	
	3-1. Controls and Indicators	3-1
	3-2. Operating Procedure	3-1
IV	THEORY OF OPERATION	
	4-1. Overall theory	4-1
	4-2. FMO and Phase Lock Assembly	4-1
	4-3. IPA and PA	4-1
	4-4. Power Supply-Regulator	4-1
	4-5. Detailed Theory	4-2
	4-6. FMO and Phase Lock Assembly	4-2
	4-7. IPA and PA	4-3
	4-8. Power Supply-Regulator	4-3
	4-9. Power and Signal Distribution	4-4
V	MAINTENANCE	
	5-1. Preventive Maintenance	5-1
	5-2. Access to Components	5-1
	5-3. Test Equipment	5-1
	5-4. Introduction to Troubleshooting	5-1
	5-5. Troubleshooting Chart	5-1

Table of Contents (Cont'd)

<u>Section</u>		<u>Page</u>
	5-6. Removal and Replacement Procedures	5-11
	5-7. Alignment and Adjustment	5-11
	5-8. Frequency Programming	5-12
	5-9. FMO and Phase Lock AFC Adjustment	5-12
	5-10. FMO and Phase Lock Coarse Frequency Adjustment	5-12
	5-11. IPA and PA Coarse Alignment	5-16
	5-12. IPA and PA Final Alignment	5-16
	5-13. FMO and Phase Lock Modulation Level Adjustment	5-17
	5-14. Recheck Coarse Frequency Adjustment	5-17
	5-15. Proof of Performance Test	5-17
VI	PARTS LISTS	
	6-1. Ordering Information	6-1
	6-2. Parts Lists	6-1
VII	DIAGRAMS	

List of Illustrations

<u>Figure</u>	<u>Title</u>	<u>Page</u>
1-1	FM-15QE FM Exciter	1-2
2-1	FM-15QE Exciter Rear Panel	2-2
3-1	FM-15QE Exciter Controls and Indicators	3-3
5-1	FM-15QE Exciter Top View with Cover Removed	5-2
5-2	FM-15QE Exciter Bottom View with Cover Removed	5-3
5-3	FMO and Phase Lock Assembly, Location of Parts	5-4
5-4	IPA and PA Assembly, Location of Parts	5-5
5-5	Power Supply-Regulator Assembly, Location of Parts	5-6

List of Tables

<u>Number</u>	<u>Title</u>	<u>Page</u>
1-1	Specifications	1-3
3-1	Exciter Controls and Indicators	3-2
5-1	Recommended Test Equipment	5-7
5-2	Troubleshooting Chart	5-8
5-3	Frequency Programming	5-13

SECTION I

GENERAL DESCRIPTION

1-1. INTRODUCTION.

This manual contains information for installation, operation, and maintenance of the AEL FM-15QE FM exciter (figure 1-1). The necessary drawings are included with, but not bound into, the manual.

The FM-15QE was designed and built for the professional FM broadcaster and is an all solid-state, on-carrier, direct FM, phase locked, frequency synthesized exciter. The FM-15QE was designed to meet or exceed FCC requirements for use in the standard FM broadcast band (88 to 108 MHz).

1-2. PHYSICAL DESCRIPTION.

The exciter is housed in a 3-1/2 X 19 X 14 in. enclosure for mounting in a standard equipment rack. All operator controls and indicators are located on the front panel. The rear panel contains signal input and output connectors, the ac power line cord and fuse, and the switch for selecting mono or stereo input signals.

The exciter is identified by a model number and serial number located on the rear panel. All correspondence in regard to this unit should reference the complete model and serial numbers.

1-3. ELECTRICAL DESCRIPTION.

The exciter is all solid-state, employing silicon transistors, diodes, and integrated circuits and featuring phase-locked stability and on-carrier direct FM for full multiplex operation with freedom from spurious responses. The exciter can withstand any VSWR phase or magnitude and provides a power output adjustable from less than 5 to greater than 20 watts. Also, the exciter may be programmed to operate on any 100 kHz increment in the FM band by using the internal 8 MHz crystal as a reference.

1-4. SPECIFICATIONS.

Table 1-1 lists the electrical and mechanical specifications for the FM-15QE exciter.

SECTION I

GENERAL DESCRIPTION

1-1. INTRODUCTION

This manual contains information for installation, operation, and maintenance of the AEL FM-15QE FM exciter (Figure 1-1). The necessary drawings are included with, but not bound into, the manual.

The FM-15QE was designed and built by the professional FM broadcaster and is an all-solid-state, on-carrier, direct FM, phase-locked, frequency-synthesized exciter. The FM-15QE was designed to meet or exceed FCC requirements for use in the standard FM broadcast band (88 to 108 MHz).

1-2. PHYSICAL DESCRIPTION

The exciter is designed for mounting in a standard equipment rack. The



TX77-006-1

The exciter is all solid-state, and provides excellent phase-locked stability and on-carrier operation with freedom from spurious responses. The exciter can be set for any VSWR phase or magnitude and provides a power output adjustable from less than 5 to greater than 100 watts. Also, the exciter may be programmed to operate on any 100 kHz increment in the FM band by using the internal 8 MHz crystal as a reference.

1-4. SPECIFICATIONS

Table 1-1 lists the electrical and mechanical specifications for the FM-15QE exciter.

Figure 1-1. FM-15QE FM Exciter.

Table 1-1. Specifications

Parameter	Specification
<u>MECHANICAL</u>	
Dimensions	3-1/2 in. H X 19 in. W X 14 in. D
Mounting Dimensions	Standard 19 in. rack
Net Weight	12 lb.
Shipping Weight	16 lb.
Maximum Operating Temp.	131°F (55°C) ambient
Environmental	0°C to +55°C operating (-15°C to +55°C with 30 min. warm up)
<u>ELECTRICAL</u>	
Primary Power	105-125/210/250 Vac, 50/60 Hz
Power Consumption	Approx 50 watts max.
Power Output	Adjustable from less than 5 to greater than 20 watts
Frequency Range	88 to 108 MHz (programmable)
Type of Emission	180F3 or 300F9
Modulation Capability (less than 1 percent THD)	150 kHz peak
Frequency Stability	± 500 Hz (-10°C to +55°C)
Output Impedance	50 ohms
VSWR Protection	Any magnitude or phase
AM Noise	Better than -55 dB
Stereo Separation	Better than 40 dB from 30 Hz to 15 kHz with AEL Model FM-15QE/SG Stereo Generator

Table 1-1. Specifications (Cont'd)

Parameter	Specification
Crosstalk (Main to SCA)	-55 dB
Crosstalk (SCA to Main)	-65 dB
Harmonic and Spurious Suppression	Better than 80 dB (with optional harmonic filter)
Mono Input: a. Impedance b. Level c. Pre-emphasis	600 ohms (balanced) +10 dBm for 75 kHz dev. at 400 Hz 75 usec \pm 1 dB (50 usec optional)
Stereo Input: a. Impedance b. Level	10k ohms 4Vpp for 75 kHz deviation
SCA Inputs (2): a. Impedance b. Level	10k ohms 1Vpp for 10 percent injection
Distortion	0.35 percent max. THD at 75 kHz dev.
FM Noise (below 75 kHz dev. with 75 usec de-emphasis)	Better than -70 dB

SECTION II

INSTALLATION

2-1. UNPACKING AND INSPECTION.

After receipt, carefully unpack the equipment and check items received against the shipping invoice. Inspect all items received for completeness and damage. Notify the shipment carrier involved in cases of loss or damage.

2-2. MECHANICAL INSTALLATION.

The following paragraphs provide the information needed to accomplish mechanical installation of the exciter.

2-3. ENVIRONMENTAL REQUIREMENTS. Locate the exciter in an environment that satisfies the following conditions:

- a. Maximum altitude: 10,000 ft.
- b. Maximum temperature: 131°F (55°C)
- c. Minimum temperature: 5°F (-15°C)

2-4. MOUNTING REQUIREMENTS. The exciter is designed for mounting in a standard 19 in. rack. Provide sufficient air space above and below the exciter to allow for dissipation of heat generated by the circuitry. If the exciter is placed above equipment that generates substantial quantities of heat, forced air cooling may be required to keep the ambient temperature of the exciter within the specified range.

Secure the exciter to the rack using four (4) each no. 10 oval head screws and finishing washers.

2-5. ELECTRICAL INSTALLATION.

The following paragraphs provide the information needed to accomplish electrical installation of the exciter.

2-6. AC POWER. The exciter is supplied wired for either 105 to 125 Vac, single phase, 50 to 60 Hz power or 210 to 250 Vac, single phase, 50 to 60 Hz power as noted on the rear panel identification plate (figure 2-1). If any doubt exists as to the voltage for which the exciter is wired, or if it is desired to change the operating voltage, refer to drawing 4051139 for power transformer connections. Clearly mark the equipment to indicate the voltage for which it is wired. Plug the line cord into a suitable receptacle.

2-7. LOW OUTPUT POWER OPERATION. If the exciter is to be used for only 12 watts or less output, it may be modified as follows to reduce heat generation:

SECTION II

INSTALLATION

2-1. UNPACKING AND INSPECTION

After receipt, carefully unpack the equipment and check items received against the shipping invoice. Inspect all items received for completeness and damage. Notify the shipment carrier involved in cases of loss or damage.

2-2. MECHANICAL INSTALLATION

The following paragraphs provide the information needed to accomplish mechanical installation of the exciter.

2-3. ENVIRONMENTAL REQUIREMENTS

The exciter is designed for operation in an environment that satisfies the following conditions:

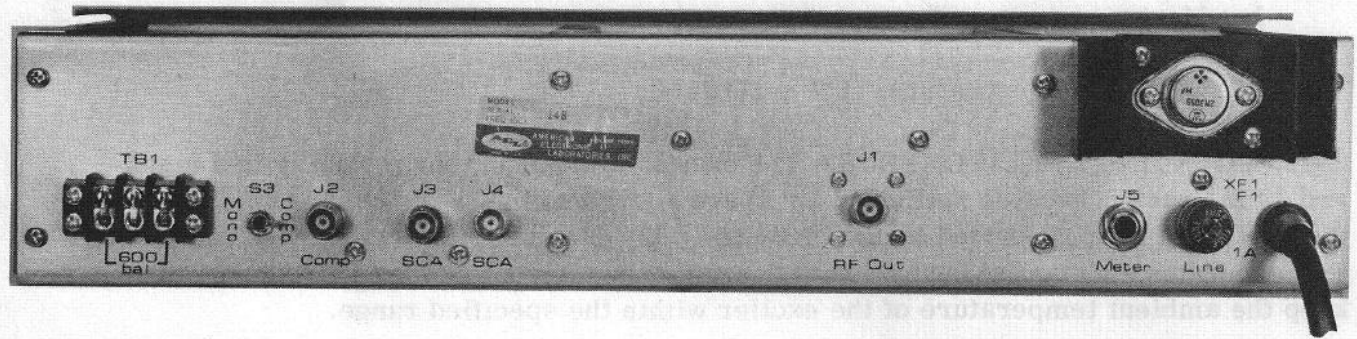

TX77-006-2

2-4. ELECTRICAL INSTALLATION

The following paragraphs provide the information needed to accomplish electrical installation of the exciter.

2-4. AC POWER. The exciter is supplied with either 100 to 125 V ac, single phase, 50 to 60 Hz power or 210 to 250 V ac, single phase, 50 to 60 Hz power as noted on the rear panel identification plate (figure 2-1). It can operate on either voltage for which the exciter is wired, or it can be rewired to operate on either voltage, refer to drawing 4051130 for power transformer connection. Clearly mark the equipment to indicate the voltage for which it is wired. Plug the line cord into a suitable receptacle.

2-5. LOW OUTPUT POWER OPERATION. If the exciter is to be used for only 12 watts or less output, it may be necessary to change the power transformer.

Figure 2-1. FM-15QE Exciter Rear Panel.

1. Remove power transformer yellow lead from CR1.
2. Connect power transformer red/yellow lead to CR1.
3. Change A4R10 from 820 ohms to 1.5 k ohms.
4. Clearly mark the equipment to indicate the low-power modification.

2-8. MONAURAL TRANSMISSION. If monaural transmission is to be used, connect the monaural audio line to TB1. The exciter requires a 600 ohm balanced audio input having a level of +10 (\pm 1) dBm for 75 kHz deviation at 400 Hz. This input provides 75 μ sec pre-emphasis. The center terminal of TB1 is connected to chassis ground.

Set Mono/Comp switch S3 to Mono.

2-9. STEREO TRANSMISSION. If stereo transmission is to be used, connect the stereo generator to Comp jack J2 using a type BNC connector and RG-58/U cable or its equivalent. This input requires 4 V peak-to-peak across 10 k ohms for 75 kHz deviation.

Set Mono/Comp switch S3 to Comp.

2-10. SCA TRANSMISSION. If SCA transmission is to be used, connect an SCA generator to SCA jack J3 or J4 using a type BNC connector and RG-58/U cable or its equivalent.

2-11. EXTERNAL METER. Meter jack J5 is provided on the rear panel to allow remote monitoring of the PA collector current. Use a 0 to 3 Amp meter connected to J5 using a three-wire stereo phone plug.

2-12. RF OUTPUT. Connect RF Out jack J1 to a transmitter or other load having a 50 ohm input impedance using a type BNC connector and RG-58/U cable or its equivalent.

CAUTION

Never operate the exciter without an RF load.

2-13. INSTALLATION CHECKOUT

Proceed as follows to ensure proper installation and operation of the exciter:

1. Recheck all installation details for conformance to requirements.
2. Ensure that all connections are properly made and tight.
3. Review Section III of this manual to gain familiarity with the location and function of all controls and indicators.

4. Connect RF Out jack J1 to a 50 ohm, 20 watts (min.) RF load using a signal sampler having a -20 to -30 dB output.
5. Connect a frequency counter to the signal sampler low level output.
6. Accomplish operating procedure of paragraph 3-2.

SECTION III

OPERATION

3-1. CONTROLS AND INDICATORS.

All operator's controls and indicators are mounted on the exciter's front panel. Table 3-1 lists the controls and indicators, describes their functions, and locates them by reference to figure 3-1.

3-2. OPERATING PROCEDURE.

1. Set MULTIMETER switch to RF.
2. Set POWER switch to on (up). Observe that POWER on indicator lights.
3. Verify that AFC LOCKED indicator lights and RF output is indicated on meter within a few seconds.

NOTE

The RF reading will vary somewhat depending on the RF load connected to the exciter.

4. Set MULTIMETER switch to all positions. Verify that meter indicates within ± 10 percent of factory-supplied information.
5. Use PWR ADJ control to set power output to level required.
6. Use FREQ ADJ control to fine-tune exciter to exact frequency.
7. To de-energize the exciter, set the POWER switch to off (down).

Table 3-1. Exciter Controls and Indicators

Item	Control or Indicator	Function
1	Power switch	Applies ac power to exciter when set to the up position.
2	POWER on indicator	Indicates, when lit, that ac power is applied to exciter
3	MULTIMETER meter	Indicates, on a scale of 0 to 1, the relative levels of functions selected by MULTIMETER switch.
4	MULTIMETER switch, having positions as follows: Vcc +15 V +5 V Ref Fmo IPA PA RF	Selects various exciter functions for display on meter: Power to integrated circuits Output of 15 Volt power supply. Output of 5 Volt power supply. Reference oscillator level. FM oscillator RF level. IPA power output (IPA collector current) PA power output (PA collector current) Exciter RF output.
5	PWR ADJ control	Screwdriver adjustment to set level of exciter RF output over a range of approx 5 to 20 watts.
6	FREQ ADJ control	Screwdriver adjustment to fine-tune exciter output RF output over a range of approx ± 500 Hz.
7	AFC LOCKED indicator	Indicates, when lit, that exciter output frequency is locked to the internal reference oscillator.

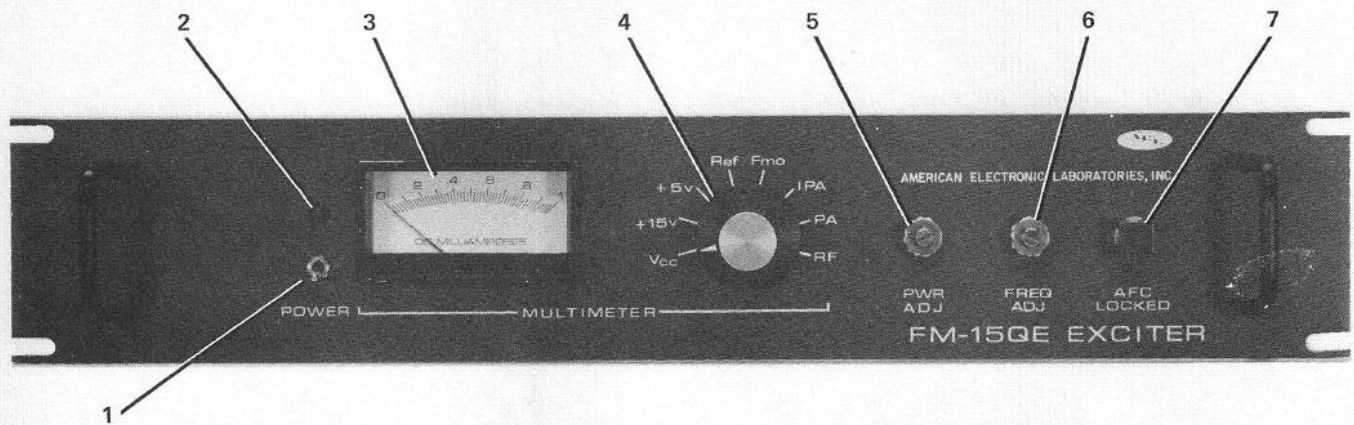

Figure 3-1. FM-15QE Exciter Controls and Indicators.

SECTION IV

THEORY OF OPERATION

4-1. OVERALL THEORY.

Refer to drawing 3050688 for a block diagram of the exciter. The exciter is divided into three functional areas:

- a. Frequency Modulation Oscillator (FMO) and Phase Lock - A2 assembly
- b. Intermediate Power Amplifier (IPA) and Power Amplifier (PA) - A3 assembly
- c. Power Supply and Regulator - A4 assembly.

4-2. FMO AND PHASE LOCK ASSEMBLY. The FMO receives pre-emphasized monaural audio, a composite (comp) audio signal from a stereo generator, or up to two SCA inputs. The FMO produces the basic frequency modulated signal which is amplified by the FMO buffer and control amplifier to approximately 100 mw. This signal is then sent to the IPA and PA assembly.

A sample of the signal from the FMO buffer is fed to a high speed divider which reduces the frequency to nominally 5 MHz ($F_c/20$). This 5 MHz signal is then processed by the programmable divider which has an output of 5 kHz regardless of the selected frequency. The output of an 8 MHz crystal controlled oscillator is digitally divided to 5 kHz. This signal is phase compared with the output of the programmable divider; the resulting signal is filtered and used to control the FMO subassembly. Thus, the programmable divider allows the use of the same high stability 8 MHz reference crystal regardless of channel assignment.

Note that this phase locked loop requires a phase error, not a frequency error, to generate its correction signal. Because of this, the output of a phase locked exciter exhibits long term phase coherence with the reference oscillator without the frequency drift associated with frequency locked loop exciters.

The lock detector senses loss of phase coherence and provides a signal that cuts off the control amplifier thereby shutting off the RF output until lock is established.

4-3. IPA AND PA. The IPA and PA assembly contains a two-stage power amplifier which raises the 100 mw output of the FMO and Phase Lock assembly to a maximum level of approximately 20 watts.

4-4. POWER SUPPLY - REGULATOR. The Power Supply - Regulator assembly contains a power supply-regulator for the IPA and PA, for the FMO (+15 Vdc), and for the FMO logic circuits (+5 Vdc). These supplies are short circuit protected. The supply-regulator for the IPA and PA can be continuously varied from 14 Vdc to 24 Vdc by using the front panel PWR ADJ control. This allows control over the power output of the IPA and PA assembly.

4-5. DETAILED THEORY.

These paragraphs provide detailed theory for the following areas of the exciter:

- a. FMO and Phase Lock Assembly
- b. IPA and PA Assembly
- c. Power Supply-Regulator
- d. Power and Signal Distribution.

4-6. FMO AND PHASE LOCK ASSEMBLY. The FMO and Phase Lock assembly receives comp audio, two SCA inputs, or monaural audio. Refer to drawing 5051277. The monaural audio is applied through transformer T2, switch A1S3, and then directly to the FMO subassembly. If stereo operation is used, the comp input is applied to the FMO through network R34, R35, and C18, and through A1S3; R34 is used to set the input level to the FMO. The two SCA inputs are capacitively coupled to the input of the FMO.

The output of the FMO subassembly is fed to the base of Q1, the FMO buffer. This stage drives Q3, the control amplifier and U1, a high speed emitter coupled logic (ECL) flip-flop. Q3 raises the power level to approximately 100 mw, a level sufficient to drive the IPA. If an unlocked condition is sensed, a signal is developed which causes Q2 to conduct thereby shorting the base of Q3 to ground and shutting off the RF output. The Ref Mtr output provides a voltage representative of FMO RF level for use by the front panel meter. The Shut Down output is not used.

Q4 provides level matching between the output of U1 ($f_c \div 2$) and the input of U2. U2 is a high speed divide by 10 circuit. The output of U2 is therefore $f_c \div 20$. U3, U4, U5 and U6 make up the programmable divider. By grounding the appropriate points (refer to table 2-1), this circuit can be made to divide by any whole number from 2 to 2000. For operation in the FM band, the circuit is made to divide by a number between 881 and 1079. When this is done, the output frequency of the programmable divider is 5 kHz when the FMO is operating on the assigned channel.

Q7, Y1 and associated circuitry form a stable 8 MHz crystal oscillator which provides the reference frequency for the system. C27 is the coarse tune capacitor and Q8 (a transistor used as a varicap) provides the voltage controlled fine tuning. Q8 is controlled by the FREQ ADJ pot on the front panel. Q9 buffers the output of the reference oscillator and provides level matching to drive U7. U7, U8 and U9 are TTL integrated circuits. The output of U9 is $8 \text{ MHz} \div 1600$ or 5 kHz. This 5 kHz square wave is differentiated and applied to Q7. When Q7 conducts, it discharges C21. C21 is charged through constant current source Q6, R46 and R47. The result of this action is to convert the 5 kHz square wave to a linear 5 kHz sawtooth. R47 is an amplitude and linearity adjustment.

The 5 kHz output of the programmable divider drives pulse amplifier Q5. The output of Q5 and the sawtooth converter are coupled to U12. This IC and associated circuitry form a sample hold phase detector. U12 is a gated Operational Transconductance Amplifier. This device has a high impedance (constant current) output. R39 and C20 form a storage circuit. U12 charges this storage circuit to the point on the input sawtooth which is coincident with the pulse from Q5. Therefore, as the phase angle between the reference derived and the FMO derived 5 kHz signals changes, the voltage on C20 rides up or down. However, since the voltage can change only when the pulse from Q5 is present, the filter required to eliminate the reference frequency is greatly reduced. U11 is a high input impedance voltage follower which eliminates any loading of the storage circuit. The low impedance output of U11 is filtered and applied to the AFC control port of the FMO subassembly thereby closing the control loop.

Q10 buffers the output of U9 (reference 5 kHz) and drives the REF position on the MULTIMETER.

U10, Q11 and Q12 form the circuit that senses lock. A 5 kHz square wave from U9 and a 5 kHz pulse from the programmable divider are fed to U10. If the two inputs are not locked, a square wave will appear at pin 6 of U10. This signal is converted to a DC level by Q11 and this level is applied to Q12 which drives the other half of U10. The output of U10 is then fed to Q2 where it shuts down the RF output and to Q13 which turns off the AFC LOCKED lamp.

4.7. IPA AND PA. The output of the FMO and Phase Lock assembly (approximately 100 mw) is applied to T1. Refer to drawing 4051142. T1 and T2 provide impedance matching to the base of Q1, the IPA. C2 stabilizes the amplifier throughout the power adjust range. C7, C8 and L2 provide impedance matching between the collector of Q1 and the base of Q2, the PA. L5, C14 and C15 provide impedance matching between the collector of Q2 and the load. CR1 and associated circuitry drives the RF position on the MULTIMETER. Parallel bypass capacitors are used on both stages to ensure that the power supply is bypassed for all frequencies. This precaution is necessary due to the extremely high low frequency gain of RF power transistors. If adequate bypassing is not used, low frequency oscillations of a sufficient magnitude to destroy the transistor can occur.

4-8. POWER SUPPLY - REGULATOR. The Power Supply-Regulator receives unregulated dc voltage from a chassis mounted rectifier. This unregulated voltage is distributed to the IPA-PA regulator, the 15 volt regulator, and the 5 volt regulator. Refer to drawing 4051141.

IPA-PA Regulator. A 12 volt zener diode, CR4, is the reference for this supply. The PWR ADJ control R1 (front panel control, across pins H and S) supplies all or part of the 12 volts across CR4 to the base of Q2. Q2 and Q3 form a DC amplifier with a gain of approximately 2. This raises the voltage supplied to the base of pass transistor A1Q1 (mounted on heat sink at rear of unit) to approximately 24.7 volts max. The

emitter of the pass transistor supplies the load through R12. If the current drawn through R12 is excessive, the voltage drop across R12 will exceed the forward voltage necessary to cause Q4 to conduct. When Q4 conducts, it fires SCR CR3 which shorts out the reference thereby causing the supply to shut down. When this occurs, C1 starts to charge through R11. When the voltage at the junction of R11 and C1 becomes more negative than the gate voltage of SCR CR1, CR1 fires discharging C1. The resulting pulse causes Q1 to momentarily interrupt the holding current through CR3 thereby cutting off CR3. This action resets the supply automatically. R27 provides unregulated dc to the front panel AFC LOCKED indicator; R28 provides a +24 Vdc output to the front panel POWER on indicator.

15 Volt Regulator. Zener diode CR6 is the reference for this regulator. Q5 and Q7 amplify the voltage across this diode to approximately 15 volts. Q6 acts similar to Q4 if the current drawn from the supply exceeds approximately 100 ma.

5 Volt Regulator. A 6.3 volt zener diode CR5 is the reference for this regulator. Q8 buffers the voltage across this diode and drives the chassis mounted pass transistor A1Q2. Q9 and R25 provide the current limit function for this supply. The limit point is approximately 500 ma. A 6 Vac input from the chassis-mounted power transformer drives diode bridge CR7 through CR10. This bridge provides collector voltage for A1Q2.

4-9. POWER AND SIGNAL DISTRIBUTION. The FMO and Phase Lock, IPA and PA, and Power Supply-Regulator assemblies are mounted on the main chassis of the exciter. Refer to drawing 4051139. The chassis also provides signal interconnections, Multi-meter and switching functions, and unregulated dc power.

Signal Interconnections. The chassis provides audio input connections (TB1 and J2), SCA input connections (J3 and J4), and the RF output connection (J1). J6 is an internal connector for connecting FMO RF to the IPA and PA assembly. J5 provides a convenient means of remotely monitoring collector current for the IPA and PA.

Multimeter Function. The front panel mounter meter (M1) receives +24 Vdc, +15 Vdc, and +5 Vdc from the Power Supply-Regulator via contacts 1, 2, and 3 respectively on switch S2. This allows monitoring of all power supply functions. S2 contacts 4 and 5 provide to M1 dc levels proportional to the RF levels of the reference 5 kHz and FMO, respectively. S2 contacts 6 and 7 provide for the monitoring of Vcc for the IPA and PA, respectively; for these functions M1 is returned to +24 Vdc. M1 also monitors exciter RF output via contact 8 of S2.

Unregulated DC Power. Ac power is applied to power transformer T1 through POWER switch S1 and fuse F1. The transformer may be wired for operation on either 120 or 240 Vac. The ac output from T1 drives rectifier CR1 which provides the unregulated dc voltage required by the Power Supply-Regulator. Front panel PWR ADJ control R1 sets the level of the dc voltage to the IPA and PA.

SECTION V

MAINTENANCE

5-1. PREVENTIVE MAINTENANCE.

Frequently check all MULTIMETER positions to ensure proper operation of all exciter circuits. Other than this, and the normal care to be exercised with electronic instruments, there are no specific preventive maintenance procedures required for the exciter.

5-2. ACCESS TO COMPONENTS.

Access to all exciter internal components can be gained by removing the top and bottom cover plates. Figures 5-1 through 5-5 locate all components by reference designation. For the complete reference designation, prefix the given reference by:

- a. A1 for the chassis
- b. A2 for the FMO and Phase Lock assembly
- c. A3 for the IPA and PA assembly
- d. A4 for the Power Supply-Regulator assembly.

5-3. TEST EQUIPMENT.

Table 5-1 lists the test equipment required for alignment and adjustment of the exciter.

5-4. INTRODUCTION TO TROUBLESHOOTING.

Troubleshooting the exciter is greatly simplified by using the front panel MULTIMETER. If a malfunction should occur, use the following general guidelines to isolate the fault:

1. Check the line fuse.
2. Use the MULTIMETER to isolate the fault to the FMO and Phase Lock assembly, the IPA and PA assembly, the Power Supply-Regulator assembly, or to chassis components.
3. Use the troubleshooting chart (table 5-2).

5-5. TROUBLESHOOTING CHART.

Table 5-2 is the troubleshooting chart for the exciter. The table lists a selected number of malfunctions based on front panel indications and provides for these malfunctions one or more probable causes and corrective actions.

SECTION V
 MAINTENANCE

5-1. PREVENTIVE MAINTENANCE

Frequently check all MULTIMETER positions to ensure proper operation of all exciter circuits. Other than this, and the normal care to be exercised with electronic instruments, there are no special preventive maintenance procedures required for the exciter.

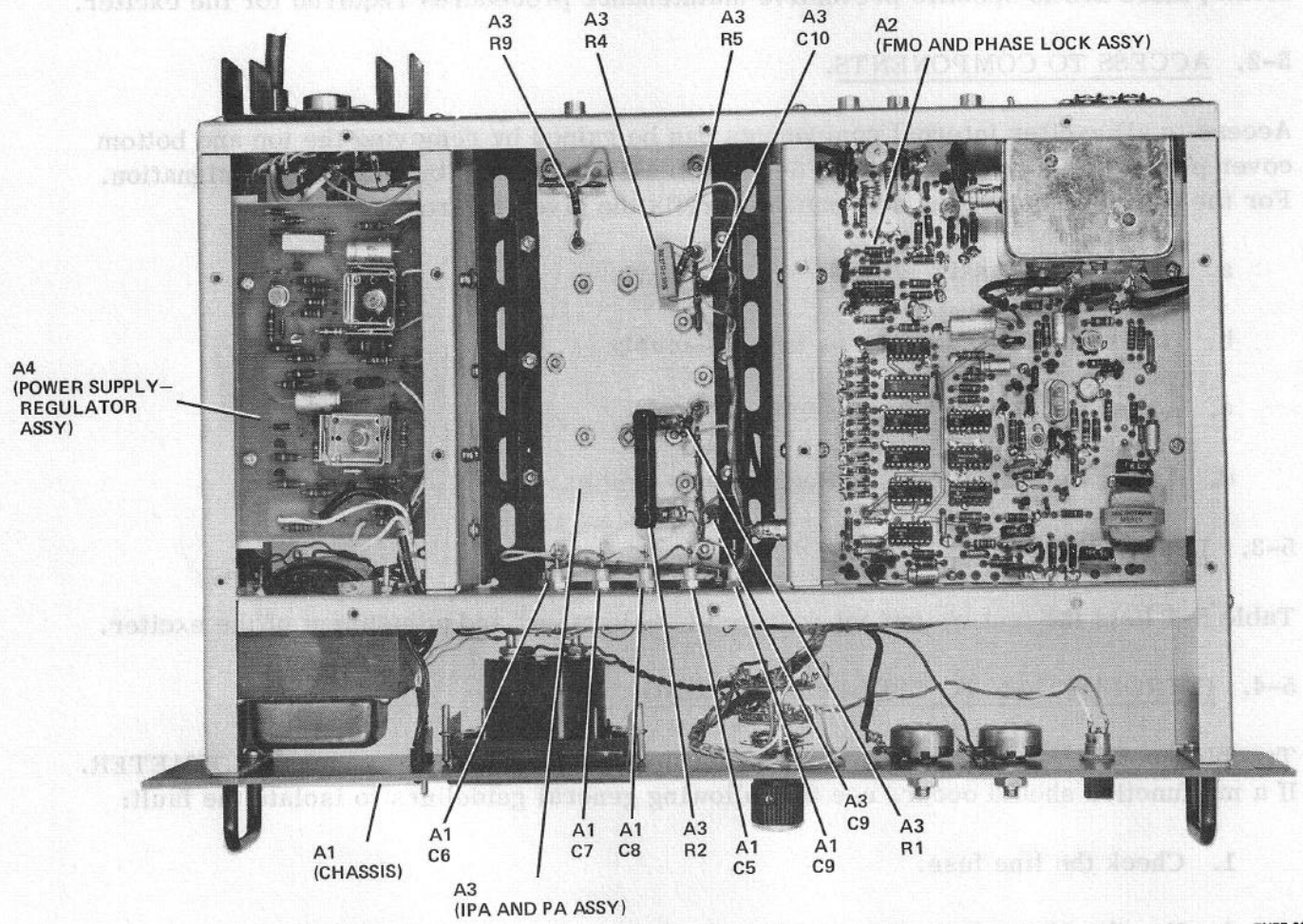

TX77-006-4

Figure 5-1. FM-15QE Exciter Top View with Cover Removed.

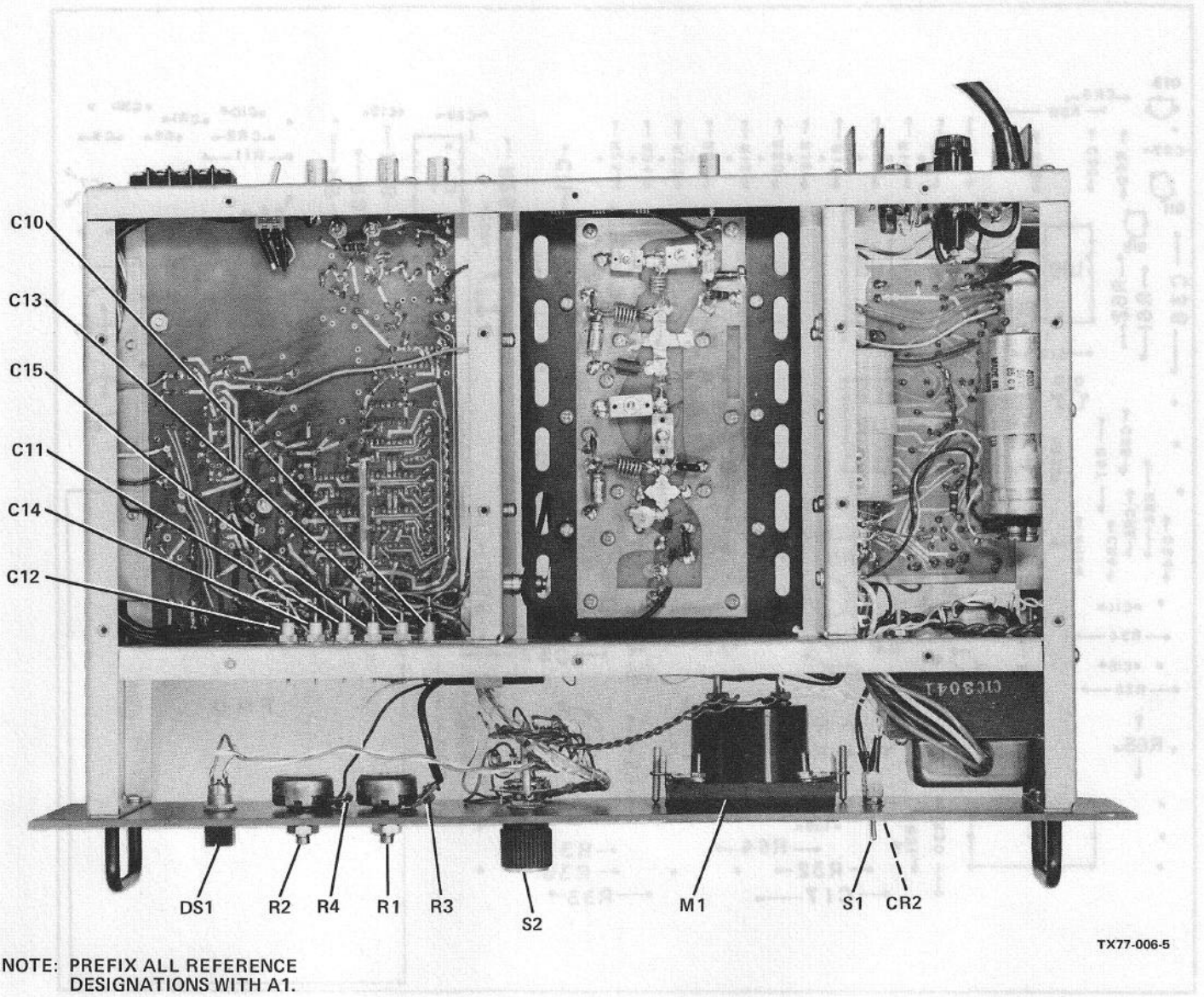
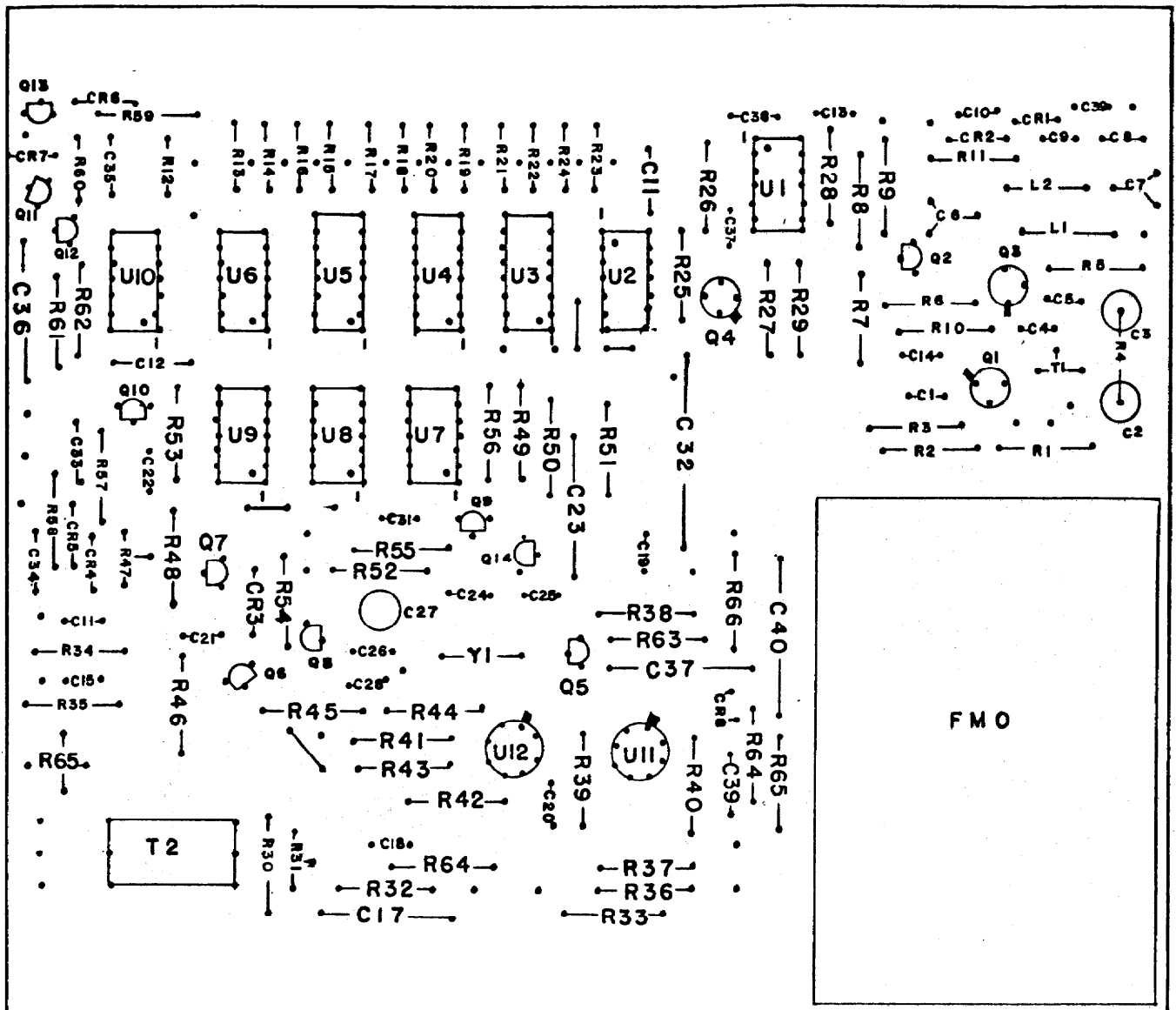
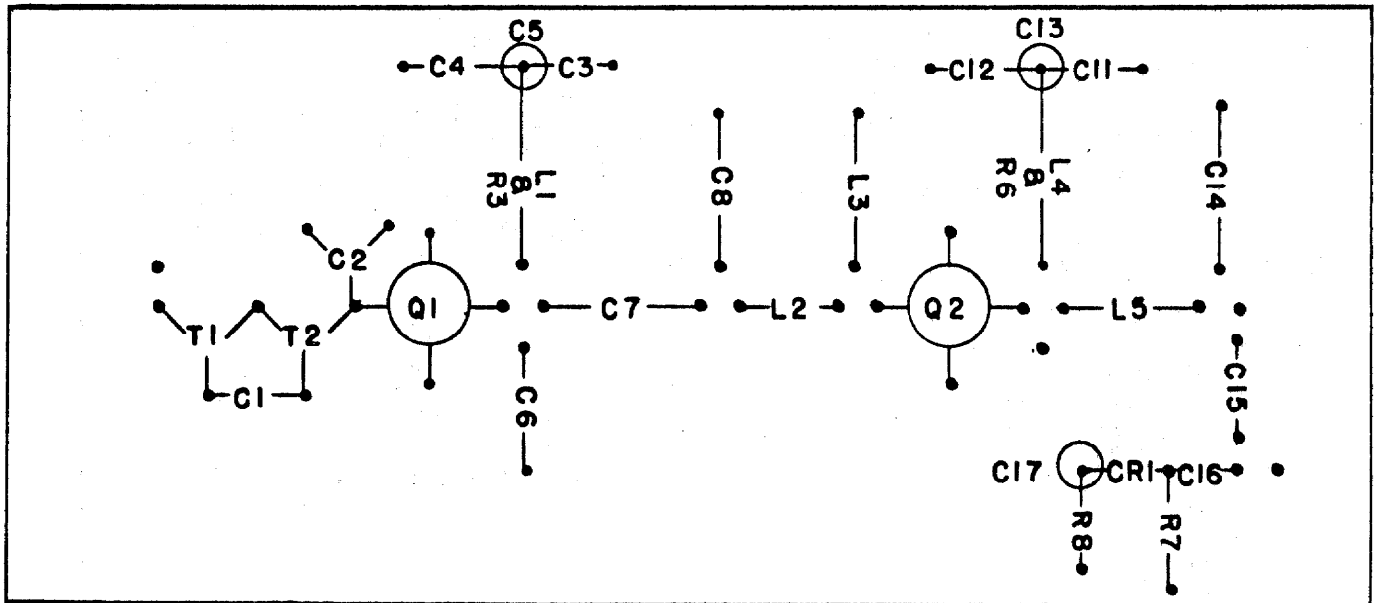

Figure 5-2. FM-15QE Exciter Bottom View with Cover Removed.



TX77-006-6

Figure 5-3. FMO and Phase Lock Assembly, Location of Parts.



TX77-006-7

Figure 5-4. IPA and PA Assembly, Location of Parts.

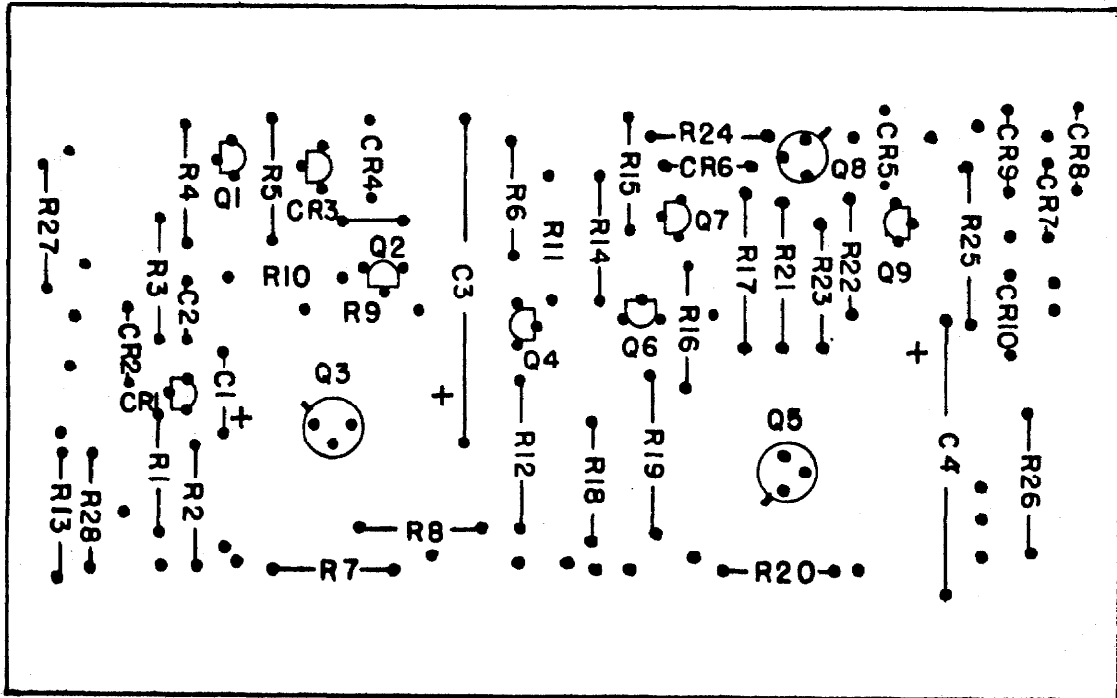

TX77-006-8

Figure 5-5. Power Supply - Regulator Assembly, Location of Parts.

Table 5-1. Recommended Test Equipment

Test Equipment	Type (or equivalent)
RF Load and Wattmeter (50 ohms, 20 Wmin.)	Bird 611
FM Modulation Monitor	QEI 671
Audio Generator (less than 0.1% distortion)	Hewlett-Packard 200CD
Dual Trace 10 MHz Oscilloscope	Telequipment D54
110 MHz Counter (Stability greater than 1 part in 10^6)	Hewlett-Packard 5245L with 5253 Plug-in
Signal Sampler (-20 to -30 dB output)	Emco M-201N
Spectrum Analyzer	Hewlett-Packard 8553B/8552A
Distortion Analyzer	Hewlett-Packard 331

Table 5-2. Troubleshooting Chart

Malfunction	Probable Cause	Corrective Action
POWER on indicator does not light; unit does not function.	<ol style="list-style-type: none"> 1. Unregulated dc power missing. 2. A4CR1 or A4CR2 defective. 	<ol style="list-style-type: none"> 1. Check A1F1 and A1CR1; replace if defective. 2. Replace A4CR1 or A4CR2.
POWER on indicator does not light; unit functions correctly.	<ol style="list-style-type: none"> 1. A1CR2 defective. 2. A4R28 open. 	<ol style="list-style-type: none"> 1. Replace A1CR2. 2. Replace A4R28.
Vcc reading on MULTIMETER is incorrect.	<ol style="list-style-type: none"> 1. IPA and PA supply-regulator defective. 2. PWR ADJ control A1R1 defective. 	<ol style="list-style-type: none"> 1. Check A1Q1, through A4Q4, A1Q1, and A4CR1 through A4CR4; replace if defective. 2. Replace A1R1.
+15 V reading on MULTIMETER is incorrect.	+15 Vdc supply-regulator defective.	Check A4Q5 through A4Q7 and A4CR6, replace if defective.
+5 V reading on MULTIMETER is incorrect.	+5 Vdc supply-regulator defective.	Check A4Q8, A4Q9, A1Q2, A4CR5, and A4CR7 through A4CR10; replace if defective.
Ref reading on MULTIMETER is incorrect.	<ol style="list-style-type: none"> 1. Reference oscillator defective. 2. Divide-by-1600 counter defective. 3. 6 kHz buffer defective. 	<ol style="list-style-type: none"> 1. Check A2Q7 through A2Q9 and A2Y1; replace if defective. 2. Check A2U7 through A2U9; replace if defective. 3. Check A2Q10; replace if defective.

Table 5-2. Troubleshooting Chart (Cont'd)

Malfunction	Probable Cause	Corrective Action
Fmo reading on MULTIMETER is incorrect.	<ol style="list-style-type: none"> 1. FMO circuit defective. 2. FMO buffer or amplifier defective. 3. FMO-unlocked circuit defective. 	<ol style="list-style-type: none"> 1. Check FMO subassembly; replace if defective. 2. Check A2Q1 or A2Q3; replace if defective. 3. Check A2Q2; replace if defective.
IPA reading on MULTIMETER is incorrect.	IPA circuit defective.	Check A3Q1; replace if defective.
PA reading on MULTIMETER is incorrect.	PA circuit defective.	Check A3Q2; replace if defective.
RF reading on MULTIMETER is incorrect.	<ol style="list-style-type: none"> 1. PA defective. 2. Improper RF load. 	<ol style="list-style-type: none"> 1. Check A3Q2; replace if defective. 2. Check RF load; ensure that exciter is working into a 50 ohm load.
AFC LOCKED indicator does not light; output frequency is stable.	<ol style="list-style-type: none"> 1. AFC LOCKED indicator defective. 2. A4R27 open. 	<ol style="list-style-type: none"> 1. Check A1DS1; replace if defective. 2. Check A4R27; replace if defective.
AFC indicator does not light; output frequency unstable.	<ol style="list-style-type: none"> 1. FMO circuits defective; Fmo reading on MULTIMETER is incorrect. 2. Reference oscillator circuits defective; Ref reading on MULTIMETER is incorrect. 3. Divider circuits defective. 	<ol style="list-style-type: none"> 1. Proceed as for incorrect FMO reading on MULTIMETER. 2. Proceed as for incorrect Ref reading on MULTIMETER. 3. Check U1 through U6; replace if defective.

Table 5-2. Troubleshooting Chart (Cont'd)

Malfunction	Probable Cause	Corrective Action
	4. Phase comparator and lock detector defective.	4. Check U10, Q11, and Q12; replace if defective.

5-6. REMOVAL AND REPLACEMENT PROCEDURES.

All exciter components are easily replaced without the use of special tools or special techniques. Observe, however, the following general precautions when making repairs to the exciter:

- a. Solid-state components are susceptible to heat damage during soldering operations. Therefore, always use a low capacity soldering iron (25 W or less) and heat sink solid-state component leads to prevent thermal damage to the item.
- b. Use only 60/40 rosin core solder.
- c. Always use a "solder sucker" or "solder wick" when unsoldering components.
- d. When removing a diode always note the location of the band on the diode (cathode end). Observe this polarity when replacing the diode.
- e. When removing a component having multiple leads, always tag the leads to ensure correct reinstallation.

5-7. ALIGNMENT AND ADJUSTMENT.

NOTE

Do not attempt troubleshooting or alignment of this unit without adequate tools and test equipment

Before starting alignment of this unit, verify that three supply voltages are present and correct. Connect the Exciter to a 50 ohm, 20 watt RF load through the signal sampler.

The following adjustments may be accomplished on the FMO and Phase Lock assembly:

- a. Frequency programming
- b. AFC adjustment - A2R47
- c. Modulation level adjustment - A2R31, A2R34
- d. Coarse frequency adjustment - A2C27.

The following adjustments may be accomplished on the IPA and PA assembly:

- a. Coarse alignment - A3C2, A3C7, A3C8, A3C14, A3C15
- b. Final alignment - A3C2, A3C7, S3C8, A3C14, A3C15.

5-8. FREQUENCY PROGRAMMING. The exciter can be reprogrammed to operate on any odd tenth-MHz frequency from 88.1 to 107.9 MHz. To accomplish this, the programmable counter must be configured with a program unique to each frequency. Proceed as follows:

1. Refer to drawing 5051277.
2. Locate the following programming points on the drawing and the FMO and Phase Lock assembly.
 - a. X1 - X2
 - b. A1, B1, C1, D1
 - c. A2, B2, C2, D2
 - d. A3, B3, C3, D3.
3. Refer to table 5-3. For the frequency to be programmed, tie to ground those programming points indicated by X, short together those programming points indicated by *, and leave open those points indicated by o.
4. Accomplish paragraphs 5-9 through 5-15 in the sequence given to check exciter alignment.

5-9. FMO AND PHASE LOCK AFC ADJUSTMENT.

1. Connect oscilloscope to junction of A2C21 and A2R43. Adjust A2R47 for the greatest amplitude linear 5 kHz sawtooth obtainable.
2. Connect oscilloscope to pin 6 of A2U11. Adjust trimmer accessible through hole in FMO can until pin 6 shows a dc level. Either side of lock will give a sawtooth signal whose frequency becomes lower as lock is approached.

5-10. FMO AND PHASE LOCK COARSE FREQUENCY ADJUSTMENT.

NOTE

Be sure of the accuracy and stability of the frequency counter.

1. Connect a frequency counter to the low level output of the signal sampler.
2. Remove all modulation from the exciter. If any modulation is present, it is necessary for the counter to have a gate time of at least four seconds in order to obtain a correct reading.
3. Set FREQ ADJ pot R2 to the center of its range.

Table 5-3. Frequency Programming

Freq. MHz	Programming Points												
	X1-X2	A1	B1	C1	D1	A2	B2	C2	D2	A3	B3	C3	D3
88.1	o		X	X					X	X	X	X	
88.3	o		X	X	X	X	X	X		X	X	X	
88.5	o			X	X	X	X	X		X	X	X	
88.7	o		X		X	X	X	X		X	X	X	
88.9	o				X	X	X	X		X	X	X	
89.1	o		X	X		X	X	X		X	X	X	
89.3	o		X	X	X		X	X		X	X	X	
89.5	o			X	X		X	X		X	X	X	
89.7	o		X		X		X	X		X	X	X	
89.9	o				X		X	X		X	X	X	
90.1	o		X	X			X	X		X	X	X	
90.3	o		X	X	X	X	X	X	X		X	X	
90.5	o			X	X	X	X	X	X		X	X	
90.7	o		X		X	X	X	X	X		X	X	
90.9	o				X	X	X	X	X		X	X	
91.1	o		X	X		X	X	X	X		X	X	
91.3	o		X	X	X		X	X	X		X	X	
91.5	o			X	X		X	X	X		X	X	
91.7	o		X		X		X	X	X		X	X	
91.9	o				X		X	X	X		X	X	
92.1	o		X	X			X	X	X		X	X	
92.3	o		X	X	X	X		X	X		X	X	
92.5	o			X	X	X		X	X		X	X	
92.7	o		X		X	X		X	X		X	X	
92.9	o				X	X		X	X		X	X	
93.1	o		X	X		X		X	X		X	X	
93.3	o		X	X	X			X	X		X	X	
93.5	o			X	X			X	X		X	X	
93.7	o		X		X			X	X		X	X	
93.9	o				X			X	X		X	X	
94.1	o		X	X				X	X		X	X	
94.3	o		X	X	X	X	X		X		X	X	
94.5	o			X	X	X	X		X		X	X	
94.7	o		X		X	X	X		X		X	X	
94.9	o				X	X	X		X		X	X	

Table 5-3. Frequency Programming (Cont'd)

Freq. MHz	Programming Points												
	X1-X2	A1	B1	C1	D1	A2	B2	C2	D2	A3	B3	C3	D3
95.1	o		X	X		X	X		X		X	X	
95.3	o		X	X	X		X		X		X	X	
95.5	o			X	X		X		X		X	X	
95.7	o		X		X		X		X		X	X	
95.9	o				X		X		X		X	X	
96.1	o		X	X			X		X		X	X	
96.3	o		X	X	X	X			X		X	X	
96.5	o			X	X	X			X		X	X	
96.7	o		X		X	X			X		X	X	
96.9	o				X	X			X		X	X	
97.1	o		X	X		X			X		X	X	
97.3	o		X	X	X				X		X	X	
97.5	o			X	X				X		X	X	
97.7	o		X		X				X		X	X	
97.9	o				X				X		X	X	
98.1	o		X	X					X		X	X	
98.3	o		X	X	X	X	X	X			X	X	
98.5	o			X	X	X	X	X			X	X	
98.7	o		X		X	X	X	X			X	X	
98.9	o				X	X	X	X			X	X	
99.1	o		X	X		X	X	X			X	X	
99.3	o		X	X	X		X	X			X	X	
99.5	o			X	X		X	X			X	X	
99.7	o		X		X		X	X			X	X	
99.9	o				X		X	X			X	X	
100.1	*	X	X	X	X	X	X	X	X	X	X	X	X
100.3	*	X		X	X	X	X	X	X	X	X	X	X
100.5	*	X	X		X	X	X	X	X	X	X	X	X
100.7	*	X			X	X	X	X	X	X	X	X	X
100.9	*	X	X	X		X	X	X	X	X	X	X	X
101.1	*	X	X	X	X		X	X	X	X	X	X	X
101.3	*	X		X	X		X	X	X	X	X	X	X
101.5	*	X	X		X		X	X	X	X	X	X	X
101.7	*	X			X		X	X	X	X	X	X	X
101.9	*	X	X	X			X	X	X	X	X	X	X

Table 5-3. Frequency Programming (Cont'd)

Freq. MHz	Programming Points												
	X1-X2	A1	B1	C1	D1	A2	B2	C2	D2	A3	B3	C3	D3
102.1	*	X	X	X	X	X		X	X	X	X	X	X
102.3	*	X		X	X	X		X	X	X	X	X	X
102.5	*	X	X		X	X		X	X	X	X	X	X
102.7	*	X			X	X		X	X	X	X	X	X
102.9	*	X	X	X		X		X	X	X	X	X	X
103.1	*	X	X	X	X			X	X	X	X	X	X
103.3	*	X		X	X			X	X	X	X	X	X
103.5	*	X	X		X			X	X	X	X	X	X
103.7	*	X			X			X	X	X	X	X	X
103.9	*	X	X	X				X	X	X	X	X	X
104.1	*	X	X	X	X	X	X		X	X	X	X	X
104.3	*	X		X	X	X	X		X	X	X	X	X
104.5	*	X	X		X	X	X		X	X	X	X	X
104.7	*	X			X	X	X		X	X	X	X	X
104.9	*	X	X	X		X	X		X	X	X	X	X
105.1	*	X	X	X	X		X		X	X	X	X	X
105.3	*	X		X	X		X		X	X	X	X	X
105.5	*	X	X		X		X		X	X	X	X	X
105.7	*	X			X		X		X	X	X	X	X
105.9	*	X	X	X			X		X	X	X	X	X
106.1	*	X	X	X	X	X			X	X	X	X	X
106.3	*	X		X	X	X			X	X	X	X	X
106.5	*	X	X		X	X			X	X	X	X	X
106.7	*	X			X	X			X	X	X	X	X
106.9	*	X	X	X		X			X	X	X	X	X
107.1	*	X	X	X	X				X	X	X	X	X
107.3	*	X		X	X				X	X	X	X	X
107.5	*	X	X		X				X	X	X	X	X
107.7	*	X			X				X	X	X	X	X
107.9	*	X	X	X					X	X	X	X	X

X - Tie to ground
o - Open
* - Short together.

4. Adjust A2C27 until exciter is on frequency.
5. Vary FREQ ADJ pot R2 from end to end. Frequency should vary approximately ± 500 Hz. Reset exciter on frequency.

5-11. IPA AND PA COARSE ALIGNMENT.

1. Using the signal sampler, connect the RF load/Wattmeter to RF Out jack J1. Connect a spectrum analyzer to the low level output of the signal sampler.
2. Apply power to the unit and observe POWER on indicator CR2 and AFC LOCKED indicator DS1. If indicators do not light refer to FMO alignment procedures (paragraphs 5-9, 5-10, and 5-13).
3. Set PWR ADJ control R1 full clockwise. Set the MULTIMETER switch S2 to the IPA position. Set A3C2 to mid-range.
4. Observe an indication of IPA collector current on the MULTIMETER. Maximize this indication by adjusting A2C6 and A2C7 of the A2 board.
5. Set the MULTIMETER switch to the PA position. Adjust A3C7 and A3C8 for a maximum reading in this position.
6. Set the MULTIMETER switch to the RF position. Adjust A3C14 and A3C15 for a maximum reading in this position. The coarse alignment is now complete. Accomplish final alignment.

5-12. IPA AND PA FINAL ALIGNMENT.

1. Connect low level output of signal sampler to spectrum analyzer.
2. Set MULTIMETER switch S2 to the RF position. Adjust A3C14 and A3C15 for a maximum reading on the multimeter. If the Power Amplifier draws excessive current and trips the power supply overload circuitry, adjust A3C15 clockwise until this condition is corrected. When this condition appears, the output power is in excess of 20 watts. Adjust A3C15 clockwise to reduce the output power to 20 watts. Readjust A3C14 for a maximum reading on the MULTIMETER.
3. Adjust A3C7 and A3C8 for a maximum reading on the MULTIMETER.
4. Turn the PWR ADJ control R1 to the max. CCW position.
5. Adjust A3C2 for stability as observed on the spectrum analyzer.
6. Turn the PWR ADJ control to the max. CW position. Readjust A3C2 if necessary to stabilize the display.

5-13. FMO AND PHASE LOCK MODULATION LEVEL ADJUSTMENT.

1. Connect an FM Modulation Monitor to the low level output of the signal sampler.
2. Using an audio generator, connect a 400 Hz +10 dBm signal to TB1. Place S3 in MONO position. Adjust A2R31 until monitor reads 100 percent.
3. Using a 400 Hz 4 Vpp (1.41 Vrms) signal to Comp jack J2. Place S3 in position. Adjust A2R34 until monitor reads 100 percent.

5-14. RECHECK COARSE FREQUENCY ADJUSTMENT. Repeat step 5-10; readjust if necessary.

5-15. PROOF OF PERFORMANCE TEST. Accomplish a proof of performance test using the Distortion Analyzer.

SECTION VI

PARTS LISTS

6-1. ORDERING INFORMATION.

To order parts for the FM-15QE Exciter, write:

American Electronic Laboratories, Inc.
P. O. Box 552
Lansdale, PA 19446

or call:

(215) 822-2929, extension 355.

Provide the following information:

- a. Station call
- b. Model and serial no.
- c. Reference designation of part if applicable (i. e., A4R10)
- d. AEL part no. or manufacturer's part no.
- e. Desired method of shipment.

6-2. PARTS LISTS.

The parts lists for the exciter are found, unbound, at the back of this manual.

SECTION VII

DIAGRAMS

The following diagrams are supplied, unbound, with this technical manual:

<u>Title</u>	<u>Drawing No.</u>
Block Diagram, FM Exciter	3050688
Schematic Diagram, FM Exciter Chassis	4051139
Schematic Diagram, Power Supply	4051141
Schematic Diagram, FM Exciter Power Amplifier	4051142
Schematic Diagram, FMO and Phase Lock	5051277

AMERICAN ELECTRONIC LABORATORIES, INC.

EXCITER PROOF OF PERFORMANCE

MODEL FM-15QE

<u>Freq. (Hz)</u>	<u>INPUT LEVEL (dB)</u>	<u>MAX.</u>	<u>MIN.</u>	<u>DIST. (%)</u>
50	<u>+10</u>	12.2	8.2	<u>.14</u>
100	<u>+10</u>	11.7	8.7	<u>.11</u>
400	<u>+10</u>	10.0		<u>.12</u>
1000	<u>+9.4</u>	10.8	7.8	<u>.13</u>
5000	<u>+2.0</u>	3.3	0.3	<u>.12</u>
7500	<u>-1.0</u>	0.2	-2.8	<u>.15</u>
10,000	<u>-3.1</u>	-1.6	-5.4	<u>.19</u>
15,000	<u>-6.0</u>	-4.4	-9.4	<u>.26</u>

PANEL METER READINGS

<u>VCC</u>	<u>.43</u>
<u>+15V</u>	<u>58</u>
<u>+5V</u>	<u>.50</u>
<u>REF</u>	<u>.48</u>
<u>FMO</u>	<u>.72</u>
<u>IPA</u>	<u>.36</u>
<u>PA</u>	<u>.31</u>
<u>RF</u>	<u>.26</u>
<u> </u>	<u> </u>
<u> </u>	<u> </u>

FM NOISE	<u>-72 dB</u>
AM NOISE	<u>> - 70 dB</u>
EXCITER SR. NO.	<u>145</u>
FREQUENCY	<u>93.7 MHz</u>
STATION	<u>WAYL</u>
MODULATION MONITOR	<u>QEI 1671</u>
DISTORTION METER	<u>HP 334A</u>
DATE	<u>9/12/77</u>
TESTER	<u>Paul Alcock</u>

THIS DOCUMENT AND THE INFORMATION AND IDEAS CONTAINED HEREIN ARE THE PROPERTY OF AMERICAN ELECTRONIC LABORATORIES, INC. OR ITS AFFILIATED CORPORATIONS. SHALL BE MAINTAINED IN CONFIDENCE, AND SHALL NOT BE DISCLOSED, DUPLICATED, COPIED OR USED AS A BASIS FOR THE MANUFACTURE OR SALE OF ANY PRODUCT OR PROCESS WITHOUT PRIOR WRITTEN CONSENT. THE U. S. GOVERNMENT AND OTHER RECIPIENTS SHALL NOT BE BOUND BY THIS RESTRICTION TO THE EXTENT THEY HAVE BY WRITTEN CONTRACT ACQUIRED GREATER RIGHTS, PURSUANT TO PART 2, SECTION 12 OF ASPR OR OTHERWISE.

REVISIONS				
ZONE	LTR	DESCRIPTION	DATE	APPROVED

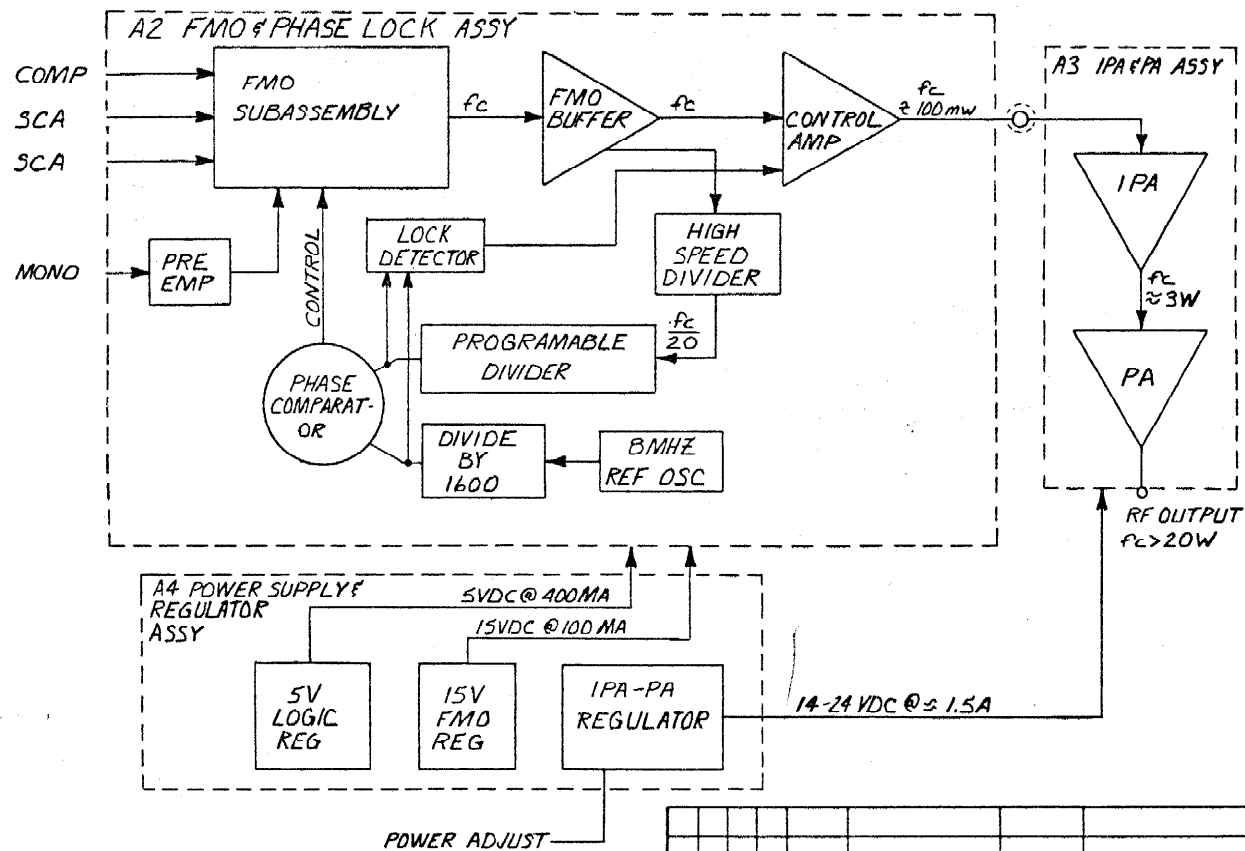

504	503	502	501	ITEM OR REF DESIG.	PART NUMBER	CODE IDENT †	DESCRIPTION	MATERIAL/FINISH	SPECIFICATION	NOTE

INTERPRET DRAWING IN ACCORDANCE WITH STANDARDS PRESCRIBED BY MIL-D-1000. DO NOT SCALE DRAWING. UNLESS OTHERWISE SPECIFIED; DIMENSIONS ARE IN INCHES AND INCLUDE PLATING THICKNESS WHEN SPECIFIED. ALL THREADS ARE UNIFIED NATIONAL SERIES, CLASS 2. REMOVE ALL BURRS AND SHARP EDGES. MANUFACTURE IN ACCORDANCE WITH MFG SPEC NO. * VENDOR ITEM—SEE SPECIFICATION OR SOURCE CONTROL DRAWING. † VENDORS IDENTIFIED BY CODE IDENT NO. ARE LISTED IN FEDERAL CATALOGING HANDBOOK H4-2.

UNLESS OTHERWISE SPECIFIED TOLERANCES OF	CONTRACT OR ORDER NO.	
BASIC DIMENSIONS	2 P. ALL DIMENSIONS	3 P. ALL DIMENSIONS
UP TO .10	$\pm .02$.005
ABOVE .10 TO .36	$\pm .03$	$\pm .010$
ABOVE .36	$\pm .06$	$\pm .015$
ANGULAR DIMENSIONS $\pm 1^\circ$		
UNLESS OTHERWISE SPECIFIED ALL HOLE TOLERANCES PER 1610123		
REF	12406	
ASSY OR PART	NEXT ASSY	USED ON
APPLICATION		

		AMERICAN ELECTRONIC LABORATORIES, INC. COLMAR, PA.	
DRAWN John Ross		DATE 9-11-75	
CHECKED R. Thomas		DATE 9-15-75	
MECH ENGR		ELEC ENGR R. Thomas	
APPROVAL (PROJECT)		DATE 9-15-75	
APPROVAL (CUSTOMER)		APPROVAL (PROJECT)	
DWG	CODE IDENT	DRAWING NO.	REV
C	93346	3050688	
SCALE	WEIGHT	SHEET 1 OF 1	
NONE	N/A		

3050688

THIS DOCUMENT, AND THE INFORMATION AND IDEAS CONTAINED HEREIN, ARE THE PROPERTY OF AMERICAN ELECTRONIC LABORATORIES, INC. OR ITS AFFILIATED CORPORATIONS, SHALL BE MAINTAINED IN CONFIDENCE, AND SHALL NOT BE DISCLOSED, DUPLICATED, COPIED OR USED AS A BASIS FOR THE MANUFACTURE OR SALE OF ANY PRODUCT OR PROCESS WITHOUT PRIOR WRITTEN CONSENT. THE U. S. GOVERNMENT AND OTHER RECIPIENTS SHALL NOT BE BOUND BY THIS RESTRICTION TO THE EXTENT THEY HAVE BY WRITTEN CONTRACT ACQUIRED GREATER RIGHTS PURSUANT TO PART 2, SECTION 12 OF ASPR OR OTHERWISE.

REVISIONS		DESCRIPTION	
ZONE	LTR		
	A	GENERAL REVISIONS	JW3

COMPONENT REFERENCE DESIGNATIONS	
LAST USED	NOT USED
AIJ	
C17	
CRI	
L5	
Q2	
R9	
T2	

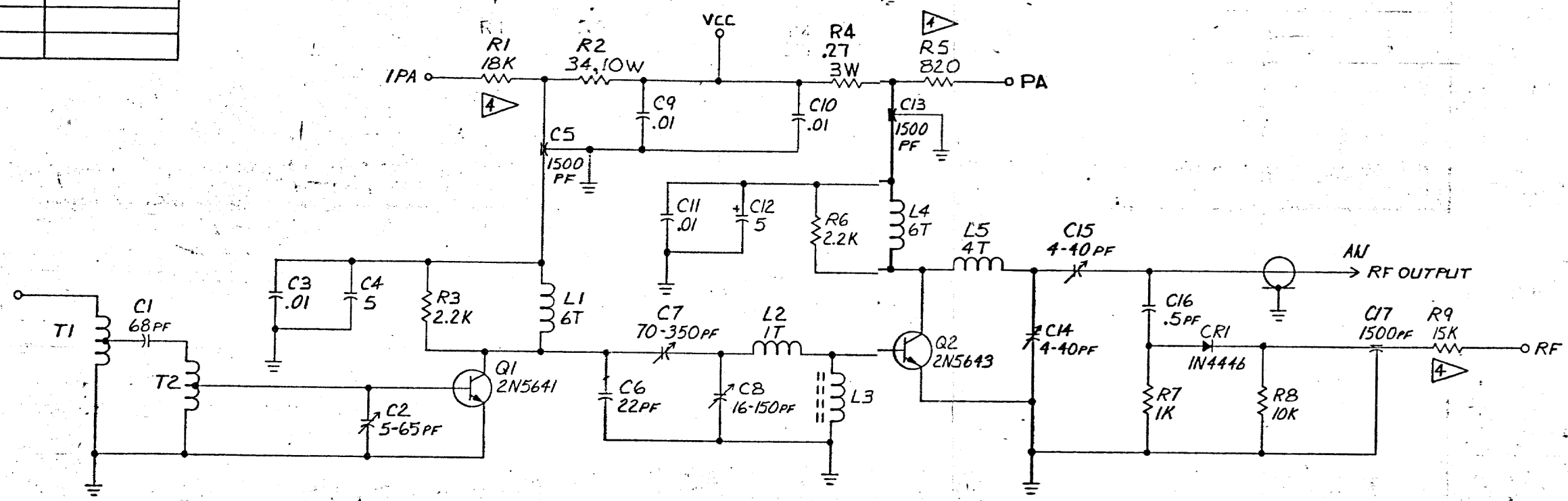

- NOTES:**
- UNLESS OTHERWISE SPECIFIED:
 - 1. REFERENCE DESIGNATIONS ARE ABBREVIATED. FOR COMPLETE DESIGNATION, PREFIX WITH UNIT NUMBER AND/OR SUBASSEMBLY DESIGNATION(S) AS APPLICABLE.
 - 2. ALL RESISTANCE VALUES ARE IN OHMS.
 - 3. ALL CAPACITANCE VALUES ARE IN UF.
 - 4. FACTORY SELECT ITEM.

INTERPRET DRAWING IN ACCORDANCE WITH STANDARDS PRESCRIBED BY MIL-STD-100. DO NOT SCALE DRAWING. UNLESS OTHERWISE SPECIFIED: DIMENSIONS ARE IN INCHES AND INCLUDE PLATING THICKNESS WHEN SPECIFIED. ALL THREADS ARE UNIFIED NATIONAL SERIES, CLASS 2. REMOVE ALL BURRS AND SHARP EDGES. MANUFACTURE IN ACCORDANCE WITH MFG. SPEC. * VENDOR ITEM-SEE SPECIFICATION OR SOURCE CONTROL DRAWING. † VENDORS IDENTIFIED BY CODE IDENT. NO. ARE LISTED IN FEDERAL CATALOGING HANDBOOK H4.2.

504	503	502	501	ITEM OR REF. DESIG.	PART NUMBER	CODE IDENT	DESCRIPTION	MATERIAL/FINISH	SP

UNLESS OTHERWISE SPECIFIED, TOLERANCES ON:		CONTRACT OR ORDER NO.		AMERICAN ELECTRONIC LAI COLMAR, PA.
SIZE	DECIMALS	DATE		
UP TO 10	±02	9-11-75		SCHEMATIC DIAGRAM FM EXCITER POWER AMPLIFIER
10 TO 30	±03	9-15-75		
ABOVE 30	±04			
UNLESS OTHERWISE SPECIFIED ALL HOLE TOLERANCES PER 1610123		DRAWN: JOHN ROSS		
		CHECKED: J. J. JONES		
		MECH ENGR:		
		ELEC ENGR: R. J. JONES		
		APPROVAL (PROJECT):		
		APPROVAL (CUSTOMER):		
REF	12406	DWG	93346	DRAWING NO. 405114
ASSY OR PART		SIZE	D	
NEXT ASSY		SCALE	NONE	WEIGHT N/A
USED ON				
APPLICATION				

THIS DOCUMENT, AND THE INFORMATION AND IDEAS CONTAINED HEREIN, ARE THE PROPERTY OF AMERICAN ELECTRONIC LABORATORIES, INC. OR ITS AFFILIATED CORPORATIONS, SHALL BE MAINTAINED IN CONFIDENCE, AND SHALL NOT BE DISCLOSED, DUPLICATED, COPIED OR USED AS A BASIS FOR THE MANUFACTURE OR SALE OF ANY PRODUCT OR PROCESS WITHOUT PRIOR WRITTEN CONSENT. THE U. S. GOVERNMENT AND OTHER RECIPIENTS SHALL NOT BE BOUND BY THIS RESTRICTION TO THE EXTENT THEY HAVE BY WRITTEN CONTRACT ACQUIRED GREATER RIGHTS PURSUANT TO PART 2, SECTION 12 OF ASPR OR OTHERWISE.

REVISIONS		DESCRIPTION	
ZONE	LTR		
	A	GENERAL REVISIONS	JW3

COMPONENT REFERENCE DESIGNATIONS	
LAST USED	NOT USED
AIJ	
C17	
CRI	
L5	
Q2	
R9	
T2	

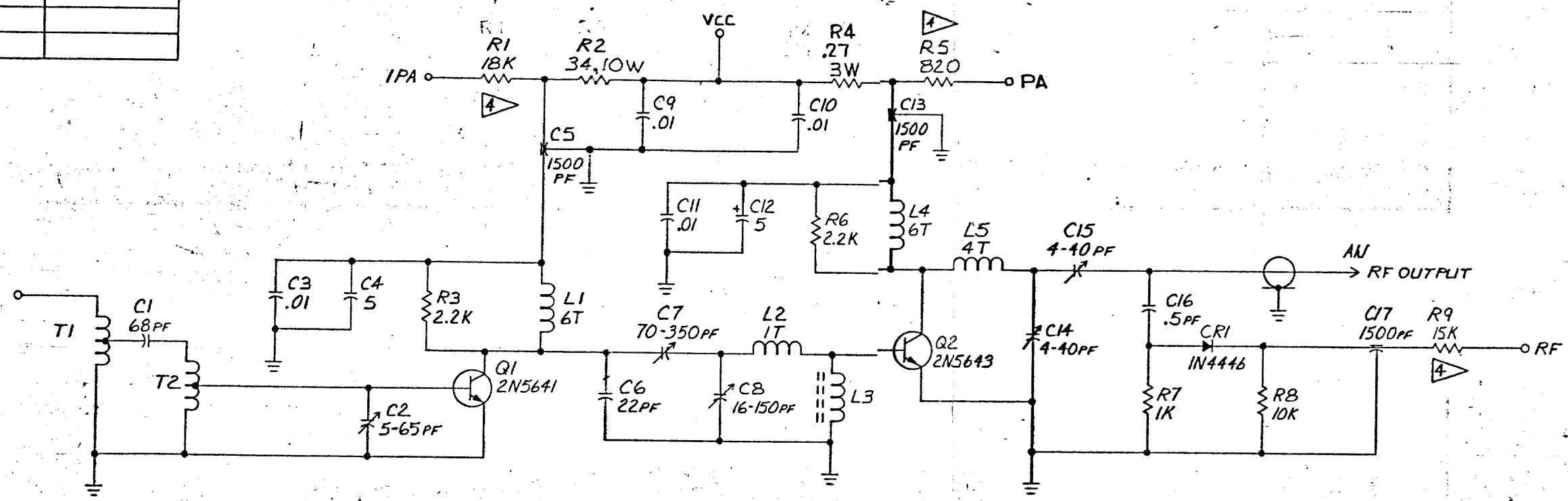

- NOTES:**
- UNLESS OTHERWISE SPECIFIED:
 - 1. REFERENCE DESIGNATIONS ARE ABBREVIATED. FOR COMPLETE DESIGNATION, PREFIX WITH UNIT NUMBER AND/OR SUBASSEMBLY DESIGNATION(S) AS APPLICABLE.
 - 2. ALL RESISTANCE VALUES ARE IN OHMS.
 - 3. ALL CAPACITANCE VALUES ARE IN UF.
 - 4. FACTORY SELECT ITEM.

INTERPRET DRAWING IN ACCORDANCE WITH STANDARDS PRESCRIBED BY MIL-STD-100. DO NOT SCALE DRAWING. UNLESS OTHERWISE SPECIFIED: DIMENSIONS ARE IN INCHES AND INCLUDE PLATING THICKNESS WHEN SPECIFIED. ALL THREADS ARE UNIFIED NATIONAL SERIES, CLASS 2. REMOVE ALL BURRS AND SHARP EDGES. MANUFACTURE IN ACCORDANCE WITH MFG. SPEC. * VENDOR ITEM-SEE SPECIFICATION OR SOURCE CONTROL DRAWING. † VENDORS IDENTIFIED BY CODE IDENT. NO. ARE LISTED IN FEDERAL CATALOGING HANDBOOK H4.2.

PARTS LIST		CONTRACT OR ORDER NO.		DRAWN		DATE	
504	503	502	501		JOHN ROSS	9-11-75	
QTY REQD				CHECKED			
UNLESS OTHERWISE SPECIFIED, TOLERANCES ON:				MECH ENGR			
DIMENSIONS				ELEC ENGR			
APPROX 36				APPROVAL (PROJECT)			
ANGULAR DIMENSIONS ONLY				APPROVAL (CUSTOMER)			
UNLESS OTHERWISE SPECIFIED ALL HOLE TOLERANCES PER 1610123				DWG			
REF				CODE IDENT			
NEXT ASSY				DRAWING NO.			
USED ON				SIZE			
APPLICATION				SCALE			
				WEIGHT			
				SHE			

AMERICAN ELECTRONIC LAI COLMAR, PA

SCHEMATIC DIAGRAM FM EXCITER POWER AMPLIFIER

DWG 93346 405114

SCALE NONE WEIGHT N/A SHE

REVISIONS			DATE
ZONE	LTR	DESCRIPTION	
	A	GENERAL REVISIONS	1/72

THIS DOCUMENT, AND THE INFORMATION AND IDEAS CONTAINED HEREIN, ARE THE PROPERTY OF AMERICAN ELECTRONIC LABORATORIES, INC. OR ITS APPLICATED CORPORATIONS. SHALL BE MAINTAINED IN CONFIDENCE AND SHALL NOT BE DISCLOSED, DUPLICATED, COPIED OR USED AS A BASIS FOR THE MANUFACTURE OR SALE OF ANY PRODUCT OR PROCESS WITHOUT PRIOR WRITTEN CONSENT. THE U. S. GOVERNMENT AND OTHER RECIPIENTS SHALL NOT BE BOUND BY THIS RESTRICTION TO THE EXTENT THEY HAVE BY WRITTEN CONTRACT ACQUIRED GREATER RIGHTS, PURSUANT TO PART 5, SECTION 25 OF ASPPR OR OTHERWISE.

COMPONENT REFERENCE DESIGNATIONS	
LAST USED	NOT USED
A4	A1
C19	
CR2	
DS1	
J5	
P1	
Q2	
R5	
S3	
T1	
XDS1	
XF1	

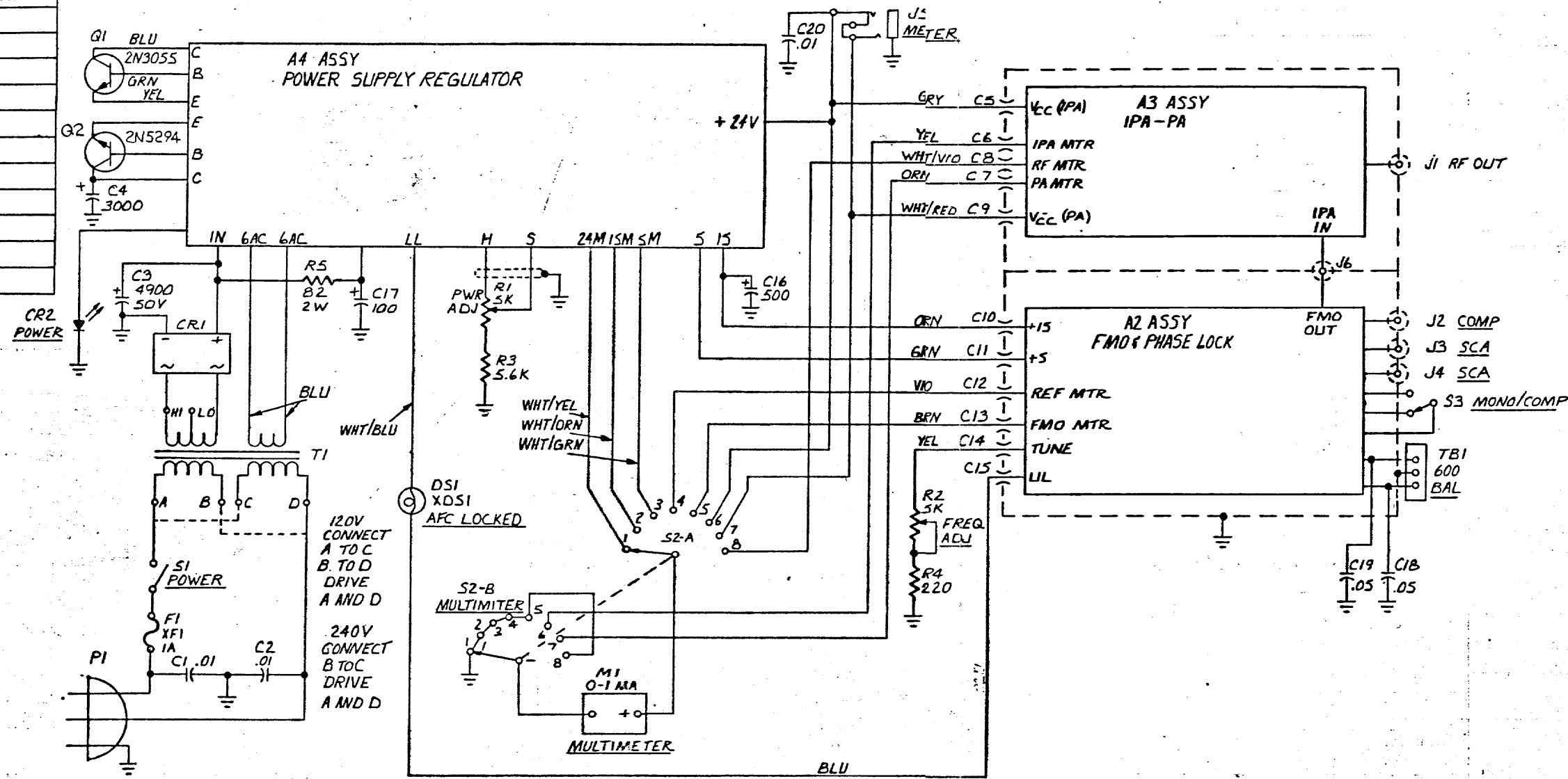

NOTES:

- UNLESS OTHERWISE SPECIFIED:
- 1. REFERENCE DESIGNATIONS ARE ABBREVIATED. FOR COMPLETE DESIGNATION, PREFIX WITH UNIT NUMBER AND/OR SUBASSEMBLY DESIGNATION(S) AS APPLICABLE.
- 2. ALL RESISTANCE VALUES ARE IN OHMS.
- 3. ALL CAPACITANCE VALUES ARE IN

INTERPRET DRAWING IN ACCORDANCE WITH STANDARDS PRESCRIBED BY MIL-STD-100. DO NOT SCALE DRAWING. UNLESS OTHERWISE SPECIFIED, DIMENSIONS ARE IN INCHES AND INCLUDE PLATING THICKNESS WHEN SPECIFIED. ALL THREADS ARE UNIFIED NATIONAL SERIES, CLASS 2. REMOVE ALL BURRS AND SHARP EDGES. MANUFACTURE IN ACCORDANCE WITH MFG. SPEC. * VENDOR ITEM-SEE SPECIFICATION OR SOURCE CONTROL DRAWING. † VENDORS IDENTIFIED BY CODE IDENT. NO. ARE LISTED IN FEDERAL CATALOGING HANDBOOK H-12.

504	503	502	501	ITEM OR REF. DESIG.	PART NUMBER	CODE IDENT †	DESCRIPTION	MATERIAL/FINISH	SPECIFICA
PARTS LIST									
UNLESS OTHERWISE SPECIFIED TOLERANCES ON:					CONTRACT OR ORDER NO.				
DIMENSIONS		PLACEMENT		TOLERANCE		DRAWN: <i>John Ross</i> DATE: 9-10-75			
AP TO 10		± .01		± .005		CHECKED: <i>[Signature]</i> DATE: 9-15-75			
10 TO 30		± .01		± .010		MECH ENGR:			
30 TO 100		± .01		± .015		ELEC ENGR: <i>[Signature]</i> DATE: 9-15-75			
ANGULAR DIMENSIONS ± .1°					APPROVAL (PROJECT):				
UNLESS OTHERWISE SPECIFIED ALL HOLE TOLERANCES PER 1610123					APPROVAL (CUSTOMER):				
REF: 12406		NEXT ASSY:		USED ON:		DWG CODE IDENT: D 93346 DRAWING NO. 4051139			
ASSY OR PART:		APPLICATION:				SCALE: N/A WEIGHT: N/A SHEET: 1			



SCHEMATIC DIAGRAM
FM EXCITER CHASSIS

THIS DOCUMENT, AND THE INFORMATION AND IDEAS CONTAINED HEREIN, ARE THE PROPERTY OF AMERICAN ELECTRONIC LABORATORIES, INC. OR ITS AFFILIATED CORPORATIONS. SHALL BE MAINTAINED IN CONFIDENCE, AND SHALL NOT BE DISCLOSED, DUPLICATED, COPIED OR USED AS A BASIS FOR THE MANUFACTURE OR SALE OF ANY PRODUCT OR PROCESS WITHOUT PRIOR WRITTEN CONSENT. THE U. S. GOVERNMENT AND OTHER RECIPIENTS SHALL NOT BE BOUND BY THIS RESTRICTION TO THE EXTENT THEY HAVE BY WRITTEN CONTRACT ACQUIRED GREATER RIGHTS: PURSUANT TO PART 2, SECTION 12 OF ASPE OR OTHERWISE.

COMPONENT REFERENCE DESIGNATIONS	
LAST USED	NOT USED
A1Q2	
C4	
CR10	
R2B	
Q9	

REVISIONS			
ZONE	LTR	DESCRIPTION	DATE
	A	GENERAL REVISIONS	JWZ 6/7/75

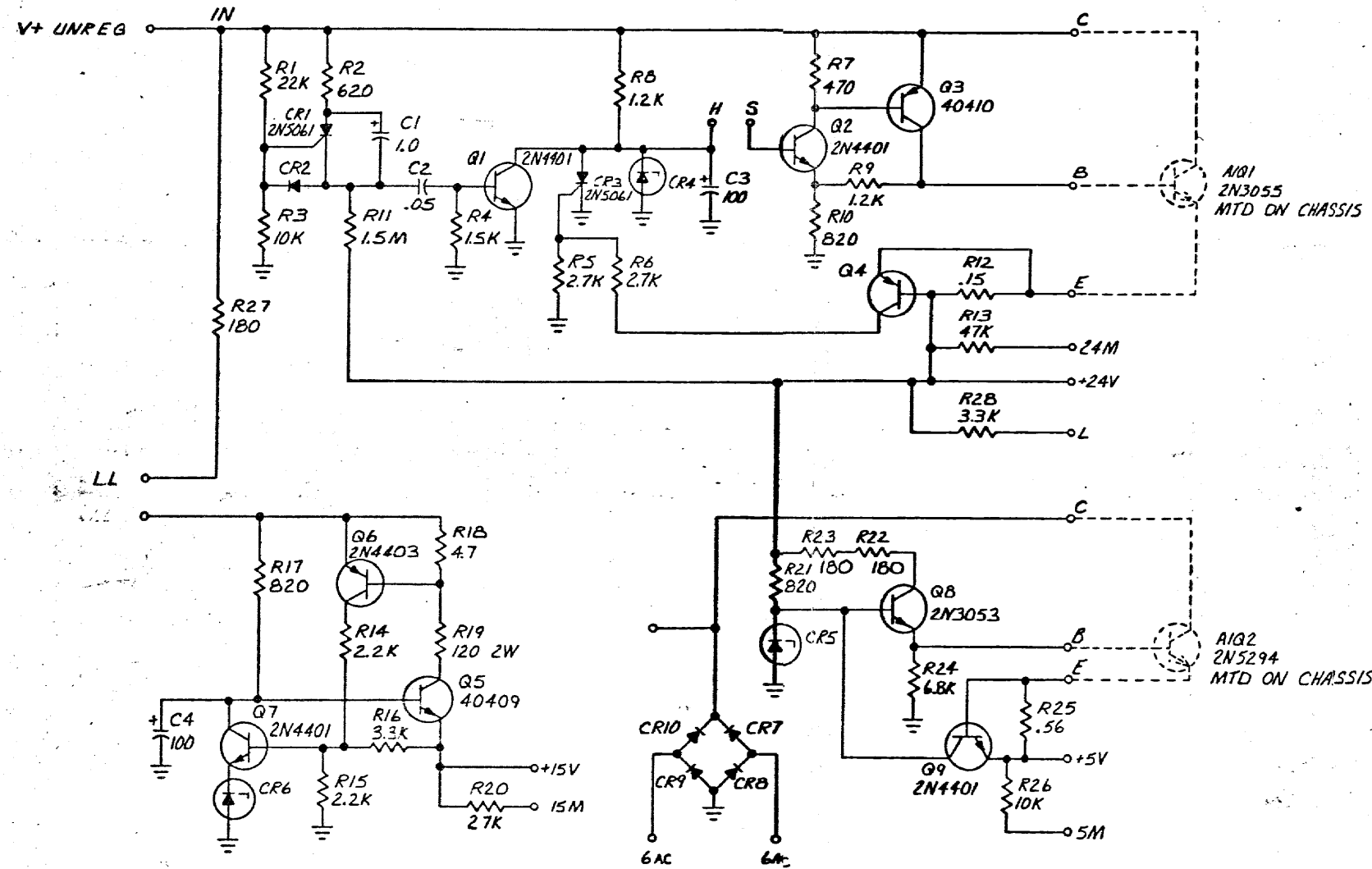

NOTES:

- UNLESS OTHERWISE SPECIFIED:
- 1. REFERENCE DESIGNATIONS ARE ABBREVIATED. FOR COMPLETE DESIGNATION, PREFIX WITH UNIT NUMBER AND/OR SUBASSEMBLY DESIGNATION(S) AS APPLICABLE.
- 2. ALL RESISTANCE VALUES ARE IN OHMS.
- 3. ALL CAPACITANCE VALUES ARE IN UF.

INTERPRET DRAWING IN ACCORDANCE WITH STANDARDS PRESCRIBED BY MIL-STD-100.
 DO NOT SCALE DRAWING.
 UNLESS OTHERWISE SPECIFIED DIMENSIONS ARE IN INCHES AND INCLUDE PLATING THICKNESS WHEN SPECIFIED.
 ALL THREADS ARE UNIFIED NATIONAL SERIES, CLASS 2. REMOVE ALL BURRS AND SHARP EDGES.
 MANUFACTURE IN ACCORDANCE WITH MFG. SPEC.
 * VENDOR ITEM-SEE SPECIFICATION OR SOURCE CONTROL DRAWING.
 † VENDORS IDENTIFIED BY CODE IDENT. NO. ARE LISTED IN FEDERAL CATALOGING HANDBOOK H4-2.

QTY REQD	504	503	502	501	ITEM OR REF DESIG.	PART NUMBER	CODE IDENT	DESCRIPTION	MATERIAL/FINISH	SPECIFICATION

UNLESS OTHERWISE SPECIFIED TOLERANCES ON:		CONTRACT OR ORDER NO.		AMERICAN ELECTRONIC LABORATORIES, INC. COLMAR, PA.
BASIC DIMENSIONS	FRAGILE DIMENSIONS	DATE		
UP TO 10	±.02	9-11-75		
10 TO 30	±.03	9-15-75		
30 TO 60	±.04			
60 TO 120	±.06			
120 TO 240	±.08			
240 TO 480	±.12			
480 TO 960	±.15			
960 TO 1920	±.20			
1920 TO 3840	±.25			
3840 TO 7680	±.30			
7680 TO 15360	±.35			
15360 TO 30720	±.40			
30720 TO 61440	±.45			
61440 TO 122880	±.50			
122880 TO 245760	±.55			
245760 TO 491520	±.60			
491520 TO 983040	±.65			
983040 TO 1966080	±.70			
1966080 TO 3932160	±.75			
3932160 TO 7864320	±.80			
7864320 TO 15728640	±.85			
15728640 TO 31457280	±.90			
31457280 TO 62914560	±.95			
62914560 TO 125829120	±1.00			

SCHEMATIC DIAGRAM POWER SUPPLY

DWG	CODE IDENT	DRAWING NO.
D	93346	4051141
SCALE	WEIGHT	SHEET / OF
N/A	N/A	1 / 1