

AC-6

95.18

100.00



**AC-8 Audio Console**

# AUTOGRAM

## AC-8 Mono/Stereo Audio Console

### SPECIFICATIONS

#### INPUT CHARACTERISTICS:

##### Sources:

- 26 stereo inputs — customer's option as to use by plug-in modules
- 1 high level cassette

##### Impedances:

- Microphone, 200 or 50 ohms
- High level 10K ohm bridge or 600 ohm terminate
- External monitor 10K ohm

##### Levels:

- Microphone -65 to -50 dBm
- High level -10 dBm to +10 dBm
- External monitor - 10 dBm to +10 dBm

##### Noise:

- Program/audition -120 dBm
- Monitor -110 dBm

##### Power Source:

- 117 or 230 Vac 50-60 Hz single phase

#### OUTPUT CHARACTERISTICS:

##### Outputs (Depends on modules used)

- 1 Stereo program
- 1 Stereo audition
- 1 Monophonic program
- 2 Monitor amplifiers
- 2 Headphone amplifiers
- 1 Cue amplifier

##### Impedances:

- Program/audition 600 ohm balanced or unbalanced — 10K ohm balanced or unbalanced
- Monitor 4-16 ohm unbalanced
- Cue 4-16 ohm unbalanced

##### Levels:

- Program/audition or mono: +8 dBm nominal — +24 dBm maximum
- Monitor — 15 watts RMS into 8 ohm load
- Cue and headset — 1 watt into 8 ohm load

##### Frequency Response:

- Program/audition  $\pm 1$  dB 30 to 15K Hz
- Monitor  $\pm 1.5$  dB 30 to 15K Hz

##### Distortion:

- Program/audition less than 0.5% THD
- Monitors less than 1.5% THD

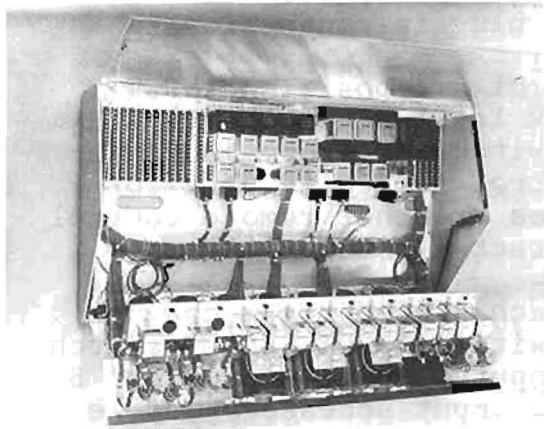
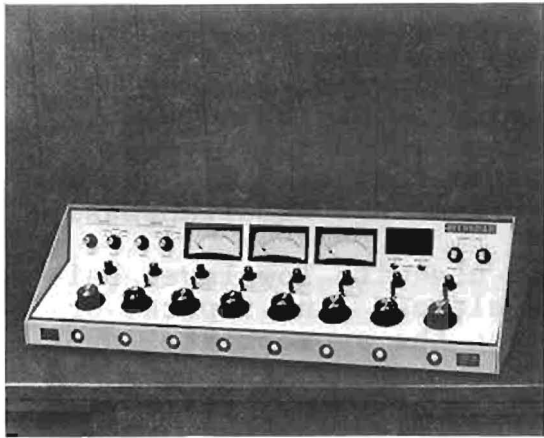

#### MOUNTING & DIMENSIONS:

- Table top with bottom or back cable entry
- Height: 10 in.; 25.4 cm.
- Depth: 20 in.; 50.8 cm.
- Width: 37 $\frac{1}{4}$  in.; 94.6 cm.

**AUTOGRAM CORPORATION**  
PO Box 456, 631 J. Place  
Plano, Texas 75074  
214-424-8585

## AUTOGRAM AC-8 AUDIO CONSOLE

### I. FUNCTIONAL DESCRIPTION

The AC-8 console, as normally configured, consists of 8 stereo mixing channels, a stereo program channel, a stereo audition channel, and a monaural program channel. All audio panel controls control right and left channels simultaneously.

All input channels can be adapted for use with low-level balanced microphone inputs, high-level balanced line inputs, or high level bridging inputs by selecting the appropriate input accessory module.

Audio input terminals and program outputs are located at the left end of the console and monitor outputs and control functions are located at the right end of the console and are accessible from the top. Optional input connectors, such as the XL type, can be supplied for direct plug-in connections.

Each stereo mixer position consists of a 2-position INPUT SELECT switch, a rotary stereo MIXER level control with CUE position, an AUDITION/PROGRAM key switch, and a push-button control switch. The pushbutton control switch is used for remote starting of cartridge machines or other remote control functions requiring a momentary contact closure.

Two stereo inputs are provided to each stereo mixer channel for channels 1 through 6. The 2-position INPUT SELECT switch connects either of the two stereo inputs, input A or input B, or two input accessory modules. The input accessory module may be a microphone preamplifier, a high-level input bridging transformer, or a high-level input matching transformer. The outputs of the monaural switch and balance control to a stereo MIXER level control attenuator. The outputs from the MIXER level attenuator are applied to an AUDITION/PROGRAM key switch that connects the mixer channel output to the stereo audition mixer channel buses, disconnects the outputs (center off position), or connects the outputs to the program mixer channel buses. Signals placed on the program mixer buses are amplified by mixer amplifiers and applied to program line level controls inside the console. Outputs from the program line level controls are amplified by two program line amplifiers and applied to output transformers to provide the 600-ohm balanced stereo program outputs. Stereo program line outputs are monitored by the left channel and right

channel VU meters on the front panel. Signals placed on the audition mixer buses are amplified by an additional set of amplifiers in the same manner as the program channels and may be monitored by left and right VU meters by placing VU meter switch in AUDITION.

Two 6-position selector switches are provided to switch stereo inputs to mixer channels 7 and 8. The stereo outputs from the REMOTE LINES SELECT switch 7A, are connected to mixer 7 with INPUT SELECT switch in A position. The stereo outputs from the REMOTE LINE SELECT switch 8A are connected to mixer 8 with INPUT SELECT switch in A position. Input 7B and 8B are single stereo inputs.

The MIXER level control attenuators provide a CUE position in the maximum counterclockwise position of the control. In this position, the mixer channel stereo outputs are combined and applied to a monaural cue bus. The signal on the cue bus is amplified by a cue amplifier and provided as an unbalanced output for driving a cue speaker or headphones.

The AC-8 consoles provide a monaural line level output that is the sum of the left and right program channels or the left and right audition channels, depending upon position of the mono mix switch. The left and right channels are connected through a level control, line amplifier, and output transformer to provide the balanced monaural line output. The panel mounted monaural channel VU meter and monaural headphone jack are connected across the monaural line output.

Two monitor amplifiers can be switched to monitor the stereo program channels, the stereo audition channels, and off-the-air stereo channel, or stereo external source. The MONITOR SELECT switch selects the stereo inputs to the monitor amplifiers, and the stereo MONITOR LEVEL control adjusts the output levels. The outputs of the monitor amplifiers are connected through two muting relays to allow connection to studio, lobby, and control room speakers.

The AC-8 console provides a headphone PHONES SELECT switch, a stereo PHONES LEVEL control, and two headphone amplifiers that allow stereo headphone monitoring of the program channel outputs, the audition channel outputs, off-the-air stereo channel, an external stereo source, or the output of the MONITOR SELECT switch.

*Monitor Muting Relay*

Table 1 AC-8 Consoles, Basic Components.

EQUIPMENT	MODEL	PART NUMBER	CHARACTERISTIC
Input Accessory Modules:			
Microphone preamplifier	MPA-1	124-0052-855	Matches microphone impedance and amplifies low-level output of microphone.
Matching transformer	MT-1	124-0052-894	Input device that isolates input from console when input level is high enough to drive console directly.
Bridging transformer	BT-1	124-0052-893	Non-loading input accessory used when input audio level is high enough to drive console directly.
Output Amplifiers:			
Line amplifier	LA-1	124-0052-858	Amplifier to drive isolation transformer.
Cue amplifier	CA-1	124-0052-861	Amplifies cue bus audio to drive cue speaker.
Headphone amplifier	HA-1	124-0052-860	Amplifies monitor audio to drive headphone.
Monitor amplifier	MA-1	124-0052-859	Amplifies monitor audio to drive monitor speakers.
Mixer Amplifier	MXA-1	124-0052-857	Active combining network amplifier.
Power Supply	PS-1	124-0052-862	Bipolar 24-Vdc rectifier regulator

## II. INSTALLATION

The arrangement of studio and control room facilities determines the location of the console in a particular station. Carefully plan the placement of equipment and wiring before beginning installation. Placement of the unit is not critical but approximately 4 inches (10.16 cm) should be left at the rear of the unit to allow for adequate ventilation. For access to all internal terminal boards, lift the front edge of the unit top and fold back; the front panel can then be pulled forward and down. The top and front panels are held in the fully open position by retaining cables. Approximately 28 inches (81.12 cm) front to back is required for the fully open unit.

During installation the following rules should be followed to eliminate grounding problems.

- A. Ground input and output cable shields at console end only. However when running signal lines from a balanced source, ground the shield at the source.

### NOTE

If noise on signal input cables is high, it may be necessary to ground shields at both ends to reduce noise levels.

- B. Use standard audio shielded twisted pair with insulated cover.
- C. Low- and high-level audio leads should be separated from power and control wiring.
- D. Use 1- to 2-inch ground strap to connect console chassis to common ground.
- E. Use shielded power leads if noise level is high.

### CAUTION

Be sure that cable shields do not come in contact with anything but grounding terminals.

### III. WIRING INSTRUCTIONS

Console location and type of installation determine the position of the input, output, and primary power wiring. Refer to figure 1 for access hole locations. Openings at the rear and bottom of the console provide access to terminal boards for incoming and outgoing leads. If the wiring is to enter from the bottom of the console, corresponding holes must be drilled through the table top for wiring access.

#### CAUTION

Connect primary power only after all other connections are made.

Refer to tables 2-1 through 2-3 for a list of input/output and control function terminal boards, and terminal functions. To ensure proper phasing of stereo signal lines, it is important to connect each twisted shielded pair to the terminals the same way. For example, if a twisted pair is used with red and white wires, always wire the red wire to + terminal, the white wire to the C (common) terminal, and the shield to the S (shield) terminal. The S terminal connects directly to the console chassis. No separate grounding is necessary.

#### A. Input Connections

Terminal boards TB1 through TB12 provide input audio connections for the AC-8 console. Each audio connection contains a + terminal, a common terminal C, and a shield terminal S. The S terminal is connected to the console chassis ground.

#### B. Mixer Channels 1 Through 8

The audio input impedance and level characteristics of a mixing channel are determined by the input accessory modules. The input may be a low-level input, bridging high-level input, or terminating high-level input. Multiple switched inputs are provided for each mixer channel, and all inputs to a mixer channel must be the same type. For example, low-level, high-level bridging, or high-level terminating.

#### C. Low-Level Inputs

The microphone preamplifier, MPA-1, is used for the low-level mixer channel. The MPA-1 preamplifier is factory wired with a 200-ohm input impedance and accepts input levels of -65dBm to -50dBm. The input impedance may be

changed to 50 ohms by making wiring changes on the console-mounted accessory socket. To change the mixer channel input impedance to 50 ohms, remove the connection between terminals 2 and 3 of the console-mounted accessory socket, install a connection between terminals 1 and 2, connections must remain on terminals 1 and 4.

#### D. High-Level Inputs - Bridging

The bridging transformer, BT-1, input accessory module provides a bridging input for the mixer channel. The bridging input provides a 10,000-ohm input impedance, which will accept input voltage levels corresponding to -10 dBm to +10 dBm across a 600-ohm terminated line (0.246 volt to 2.46 volts rms).

#### E. High-Level Inputs - Terminating

The matching transformer, MT-1, input accessory module provides a 600-ohm terminating line input for the mixer channel. The terminating input will accept input levels of -10 dBm to +10 dBm.

#### F. Remote Inputs

Two 6-position selector switches are provided for switching stereo inputs to mixer channels 7 and 8 of the AC-8 console. All inputs switched into a mixer channel must be the same type. Normally mixer channels 7 and 8 will employ the MT-1 matching transformer or the BT-1 bridging transformer input accessory modules. Table 2-1 provides the input terminal connections.

#### G. External Monitor Inputs

The AC-8 console contains provisions for an external stereo monitor input and an off-the-air stereo monitor input. Each of these inputs has a 10,000-ohm balanced input impedance.

#### H. Cassette Input

The AC-8 console contains two miniature phone jacks located in the lower right-hand corner of the front panel area. These jacks terminate in wiring pigtailed located inside the console adjacent to the mixer input area. These cables enable the console installer to connect the cassette inputs to any suitable mixer input during the process of the



installation. The wires are labeled for identification. Care should be taken to properly phase the left and right channels to the selected input.

#### I. Stereo/Monaural Input Switching

A stereo/monaural input switch for each mixer is located on the back of the front panel adjacent to the plug-in input accessory module sockets. This switch must be placed in either the S (stereo) or M (monaural) position as dictated by the type of input selected for the applicable mixer. In the monaural position, the output of the right channel is disconnected and the left channel input is connected to both left and right channel outputs of the mixer.

#### J. Program and Audition Line Outputs

Connections to the 600-ohm isolated program and audition line outputs are made through terminal board TB<sub>2</sub> on output amplifier chassis A2. Refer to table 2-2 for connections.

#### K. Monitor Speaker Outputs

Two separate stereo monitor speaker output connections are provided through two separate **muting** relays for studio and/or remote speaker connections. Refer to table 2-3 for audio connections. Muting relay controls are connected as described in paragraph entitled "Muting Relay Connections", which follows.

#### NOTE

Do not ground either conductor of the monitor speaker lines--use twisted pair shielded cable 18 gauge or larger.

#### L. Cue Output

A single cue output is provided to drive a customer-furnished cue speaker. Refer to table 2-2 for connections.

#### NOTE

Do not ground either conductor of the cue speaker line.

#### M. Stereo Headphone Output

The consoles contain a separate jack located in the lower left-hand corner for headphone monitoring. The output will accept headphone impedances of 8 ohms to 50 kilohms, eliminating the need of special headphones or impedance matching transformers.

#### N. Muting Relay Connections

Two muting relays are provided for silencing monitor speakers when a program/audition switch is placed in the PROGRAM or AUDITION position. The relays must be strapped to the selected program/audition switch for operation. Refer to table 2-3 for control connections. For example, to mute the speakers with the PROGRAM/AUDITION MIXER 1 switch in the PROGRAM position, connect the "mute key ground" line for 1 PGM to the "mute relay to ground" terminals of the relay to which the monitor speaker is connected. If the monitor speakers to be muted are connected to relay K1, jumper AC-8 TB16-1 to TB16-13.

#### O. Pushbutton Control Functions

The front panel momentary pushbutton controls are wired to terminal boards and are used to start externally located equipment. The pushbuttons are to be used only with contact closure dc switched equipment. No ac should be wired through the pushbutton switches. Refer to table 2-3 for connections to the pushbutton switch contacts through the terminal boards. Each pair of connections represents a single set of normally open contacts. Contact rating is 1 ampere maximum.

Table 2-1 AC-8 Audio Input Connections

CONTROL	FUNCTION		ASSY NO	INPUT	TERMINAL NO			
	SW POS	CHAN			TB ( )	+	C	S
MIXER	1	A	L	A5	1	1	2	3
	1	A	R	A5	2	1	2	3
	1	B	L	A5	3	1	2	3
	1	B	R	A5	4	1	2	3
	2	A	L	A5	1	4	5	6
	2	A	R	A5	2	4	5	6
	2	B	L	A5	3	4	5	6
	2	B	R	A5	4	4	5	6
3	A	L	A5	1	7	8	9	
3	A	R	A5	2	7	8	9	
3	B	L	A5	3	7	8	9	
3	B	R	A5	4	7	8	9	
4	A	L	A5	1	10	11	12	
4	A	R	A5	2	10	11	12	
4	B	L	A5	3	10	11	12	
4	B	R	A5	4	10	11	12	
5	A	L	A5	1	13	14	15	
5	A	R	A5	2	13	14	15	
5	B	L	A5	3	13	14	15	
5	B	R	A5	4	13	14	15	
6	A	L	A5	5	1	2	3	
6	A	R	A5	6	1	2	3	
6	B	L	A5	7	1	2	3	
6	B	R	A5	8	1	2	3	
7	A1	L	A5	5	4	5	6	
7	A1	R	A5	6	4	5	6	
7	A2	L	A5	5	7	8	9	
7	A2	R	A5	6	7	8	9	
7	A3	L	A5	5	10	11	12	
7	A3	R	A5	6	10	11	12	
7	A4	L	A5	5	13	14	15	
7	A4	R	A5	6	13	14	15	
7	A5	L	A5	7	4	5	6	
7	A5	R	A5	8	4	5	6	
7	A6	L	A5	7	7	8	9	
7	A6	R	A5	8	7	8	9	
7	B	L	A5	7	10	11	12	
7	B	R	A5	8	10	11	12	

Table 2-1 AC-8 Audio Input Connections (Cont)

CONTROL	FUNCTION		ASSY NO	INPUT TB ( )	TERMINAL NO		
	SW POS	CHAN			±	C	S
MIXER							
8	A1	L	A5	9	1	2	3
8	A1	R	A5	10	1	2	3
8	A2	L	A5	9	4	5	6
8	A2	R	A5	10	4	5	6
8	A3	L	A5	9	7	8	9
8	A3	R	A5	10	7	8	9
8	A4	L	A5	9	10	11	12
8	A4	R	A5	10	10	11	12
8	A5	L	A5	11	1	2	3
8	A5	R	A5	12	1	2	3
8	A6	L	A5	11	4	5	6
8	A6	R	A5	12	4	5	6
8	B	L	A5	11	7	8	9
8	B	R	A5	12	7	8	9
MONITOR/ PHONES SELECT							
	EXTERNAL	L	A5	7	13	14	15
	AIR	R	A5	8	13	14	15
		L	A5	9	13	14	15
		R	A5	10	13	14	15

Table 2-2 AC-8 Audio Output Connections

OUTPUT	CHANNEL	ASSY NO	OUTPUT TB ( )	TERMINAL NO		
Program out	L	A2	2	1	2	3
Program out	R	A2	2	4	5	6
Program out	MONO	A2	2	7	8	9
Audition out	L	A2	2	10	11	12
Audition out	R	A2	2	13	14	15
Monitor K1	L	A4	2	1	2	-
Monitor K1	R	A4	2	3	4	-
Monitor K2	L	A4	2	5	6	-
Monitor K2	R	A4	2	7	8	-
Cue Output	-	A4	2	9	10	11

Table 2-3 AC-8 Control Function Connections

CONTROL	ASSY NO	CONTROL TB ( )	SWITCH TERMINALS		TERMINAL
<b>Pushbutton</b>					
1A	A6	13	1	2	-
1B	A6	13	3	4	-
2A	A6	13	5	6	-
2B	A6	13	7	8	-
3A	A6	13	9	10	-
3B	A6	13	11	12	-
4A	A6	14	1	2	-
4B	A6	14	3	4	-
5A	A6	14	5	6	-
5B	A6	14	7	8	-
6A	A6	14	9	10	-
6B	A6	14	11	12	-
7A	A6	15	1	2	-
7B	A6	15	3	4	-
8A	A6	15	5	6	-
8B	A6	15	7	8	-
<b>Mute Key Ground</b>					
1 PGM	A6	16	-	-	1
1 AUD	A6	16	-	-	2
2 PGM	A6	16	-	-	3
2 AUD	A6	16	-	-	4
3 PGM	A6	16	-	-	5
3 AUD	A6	16	-	-	6
4 PGM	A6	16	-	-	7
4 AUD	A6	16	-	-	8
5 PGM	A6	16	-	-	9
5 AUD	A6	16	-	-	10
6 PGM	A6	16	-	-	11
6 AUD	A6	16	-	-	12
7 PGM	A6	15	-	-	9
7 AUD	A6	15	-	-	10
8 PGM	A6	15	-	-	11
8 AUD	A6	15	-	-	12
<b>On-Air Warning Light Connections*</b>					
K1	A6	13	13	14	-
K2	A6	14	13	15	-
<b>Cue Muting*</b>					
K1	A6	13	13	15	-
K2	A6	14	13	15	-
<b>Mute Relay To Ground</b>					
K1	A6	16	-	-	13
K2	A6	16	-	-	14

\* K1 or K2 can not be used simultaneously for on-air warning and cue mute.

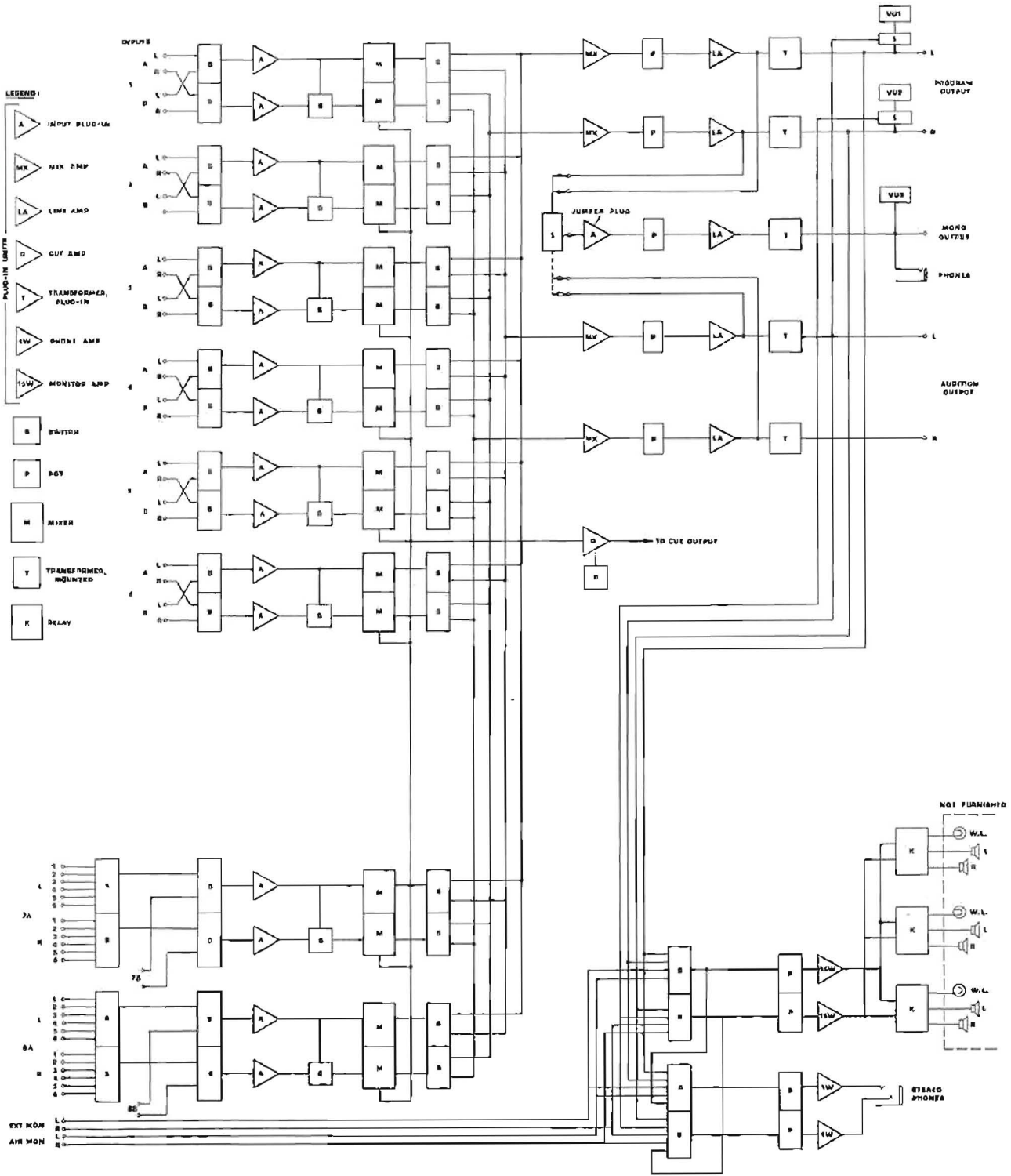

- LEGEND:**
- A INPUT BUFFER
  - MX MIX AMP
  - LA LINE AMP
  - D CUF AMP
  - T TRANSFORMER, PLUG-IN
  - 10W MONITOR AMP
  - 10W MONITOR AMP
  - B BUFFER
  - P PAD
  - M MIXER
  - Y TRANSFORMER, MOUNTED
  - K DELAY

BLOCK DIAGRAM  
AC-R AUDIO CONSOLE

4-72 CW 5202P

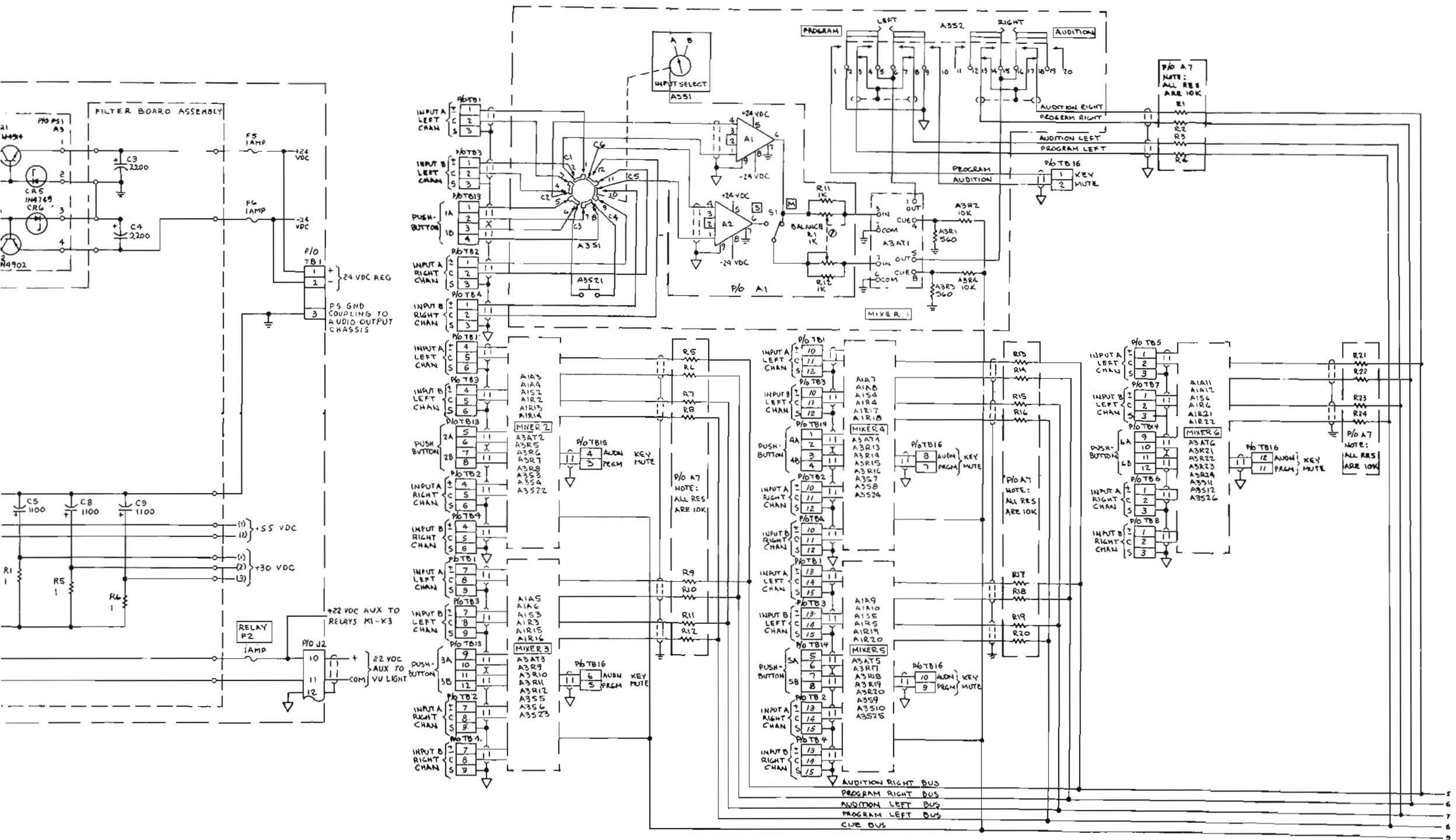
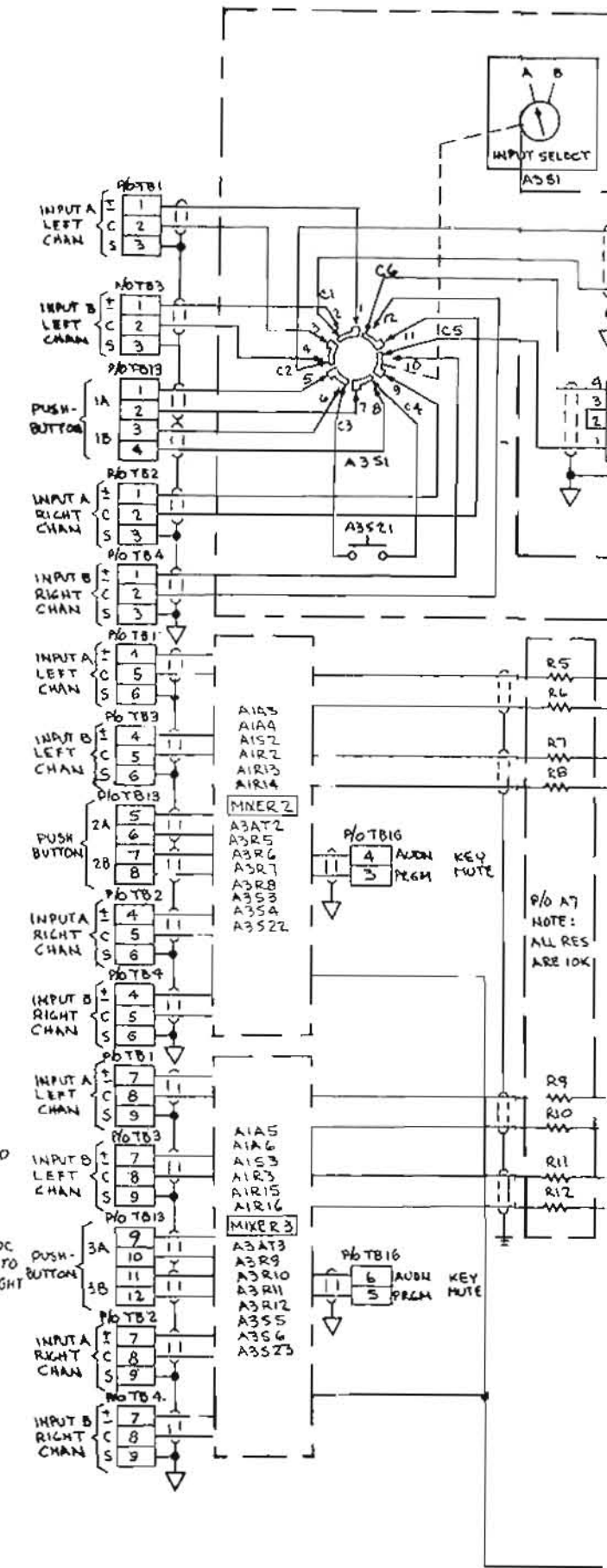
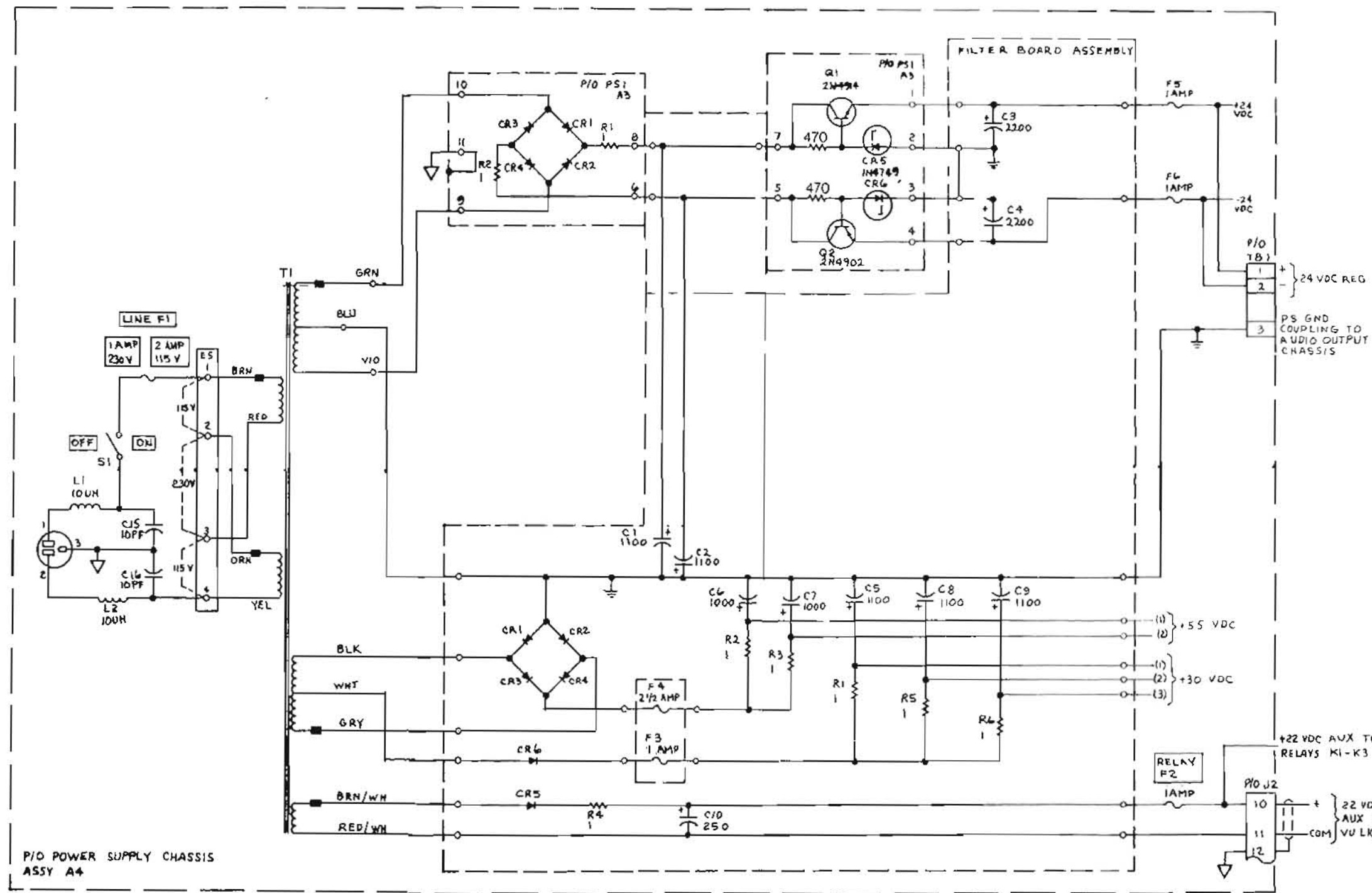
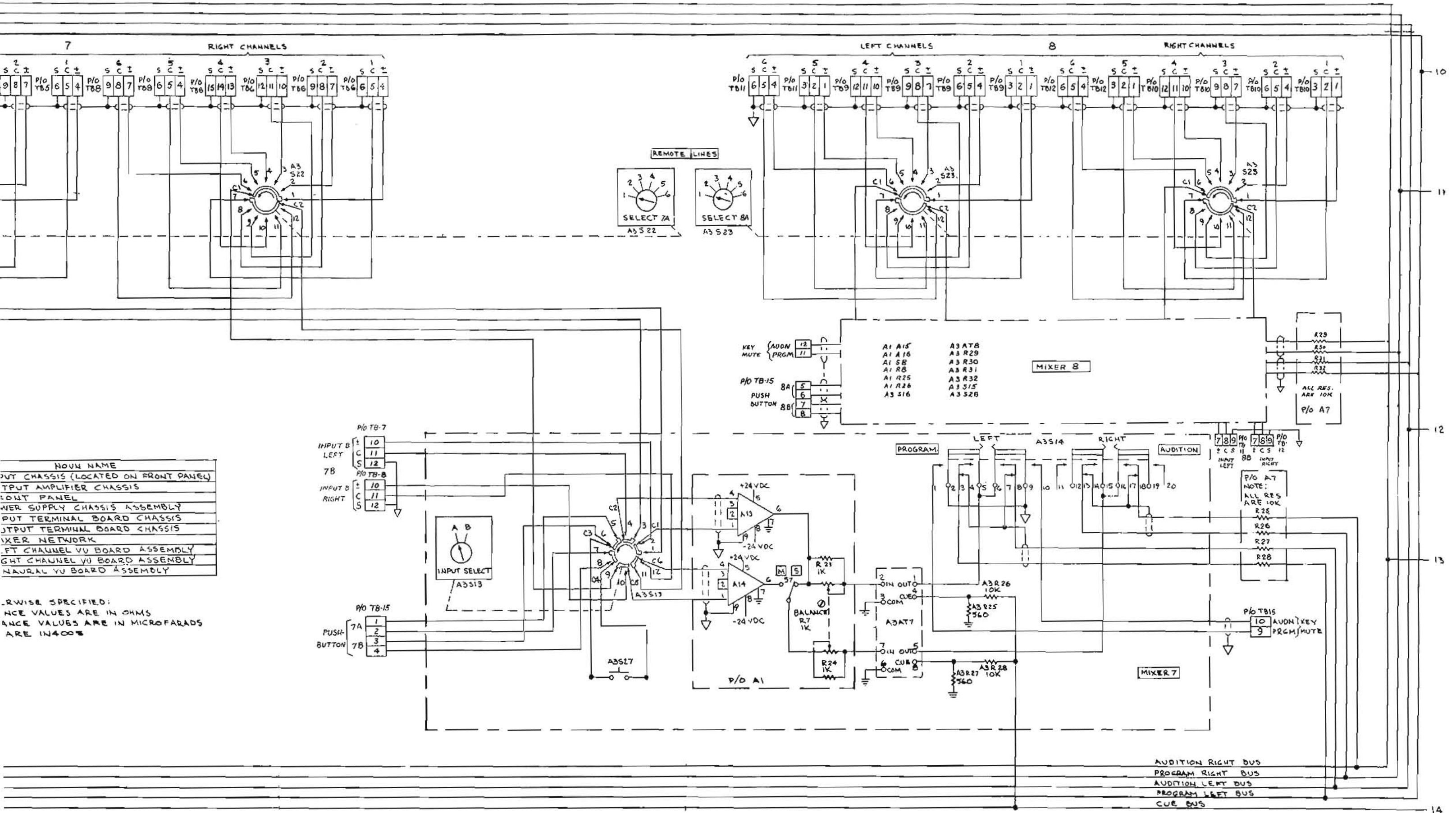

Figure 2 AC-8 Console Chassis, Schematic Diagram (Sheet 1 of 3).







NOVN NAME
INPUT CHASSIS (LOCATED ON FRONT PANEL)
OUTPUT AMPLIFIER CHASSIS
FRONT PANEL
POWER SUPPLY CHASSIS ASSEMBLY
OUTPUT TERMINAL BOARD CHASSIS
INPUT TERMINAL BOARD CHASSIS
MIXER NETWORK
LEFT CHANNEL VU BOARD ASSEMBLY
RIGHT CHANNEL VU BOARD ASSEMBLY
NAURAL VU BOARD ASSEMBLY

UNLESS OTHERWISE SPECIFIED:  
 RESISTANCE VALUES ARE IN OHMS  
 CAPACITANCE VALUES ARE IN MICROFARADS  
 ALL VALUES ARE IN 400%

AUDITION RIGHT BUS  
 PROGRAM RIGHT BUS  
 AUDITION LEFT BUS  
 PROGRAM LEFT BUS  
 CUE BUS

Figure 2 AC-8 Console Chassis, Schematic Diagram (Sheet 2 of 3).

1  
2  
3  
4

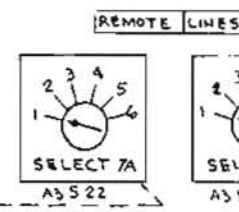
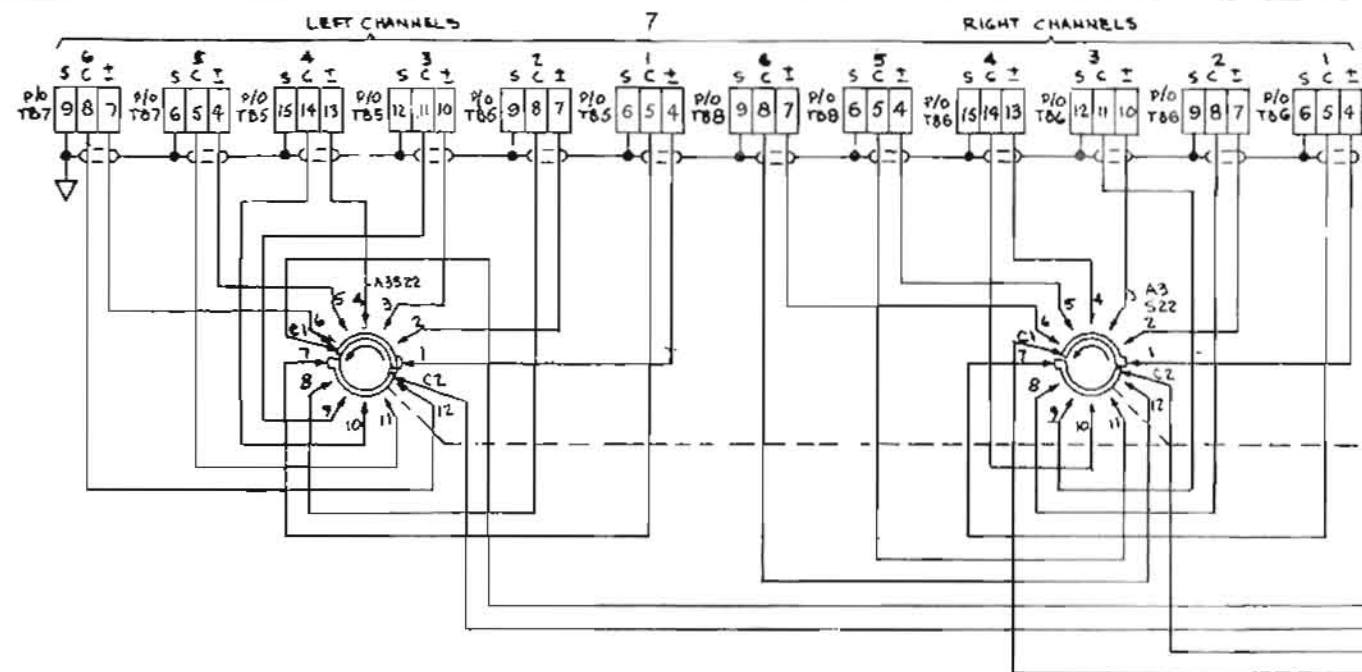

ASSEMBLY	HOW NAME
A1	INPUT CHASSIS (LOCATED ON FRONT PANEL)
A2	OUTPUT AMPLIFIER CHASSIS
A3	FRONT PANEL
A4	POWER SUPPLY CHASSIS ASSEMBLY
A5	INPUT TERMINAL BOARD CHASSIS
A6	OUTPUT TERMINAL BOARD CHASSIS
A7	MIXER NETWORK
A8	LEFT CHANNEL VU BOARD ASSEMBLY
A9	RIGHT CHANNEL VU BOARD ASSEMBLY
A10	MONAURAL VU BOARD ASSEMBLY

NOTE:  
UNLESS OTHERWISE SPECIFIED:  
ALL RESISTANCE VALUES ARE IN OHMS  
ALL CAPACITANCE VALUES ARE IN MICROFARADS  
ALL DIODES ARE IN4002

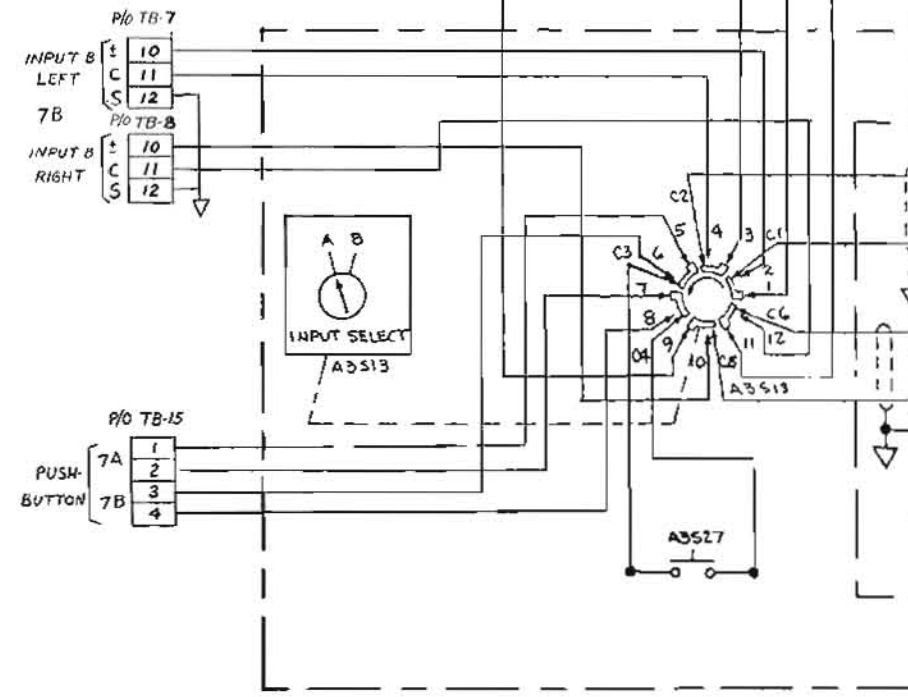

5  
6  
7  
8  
9

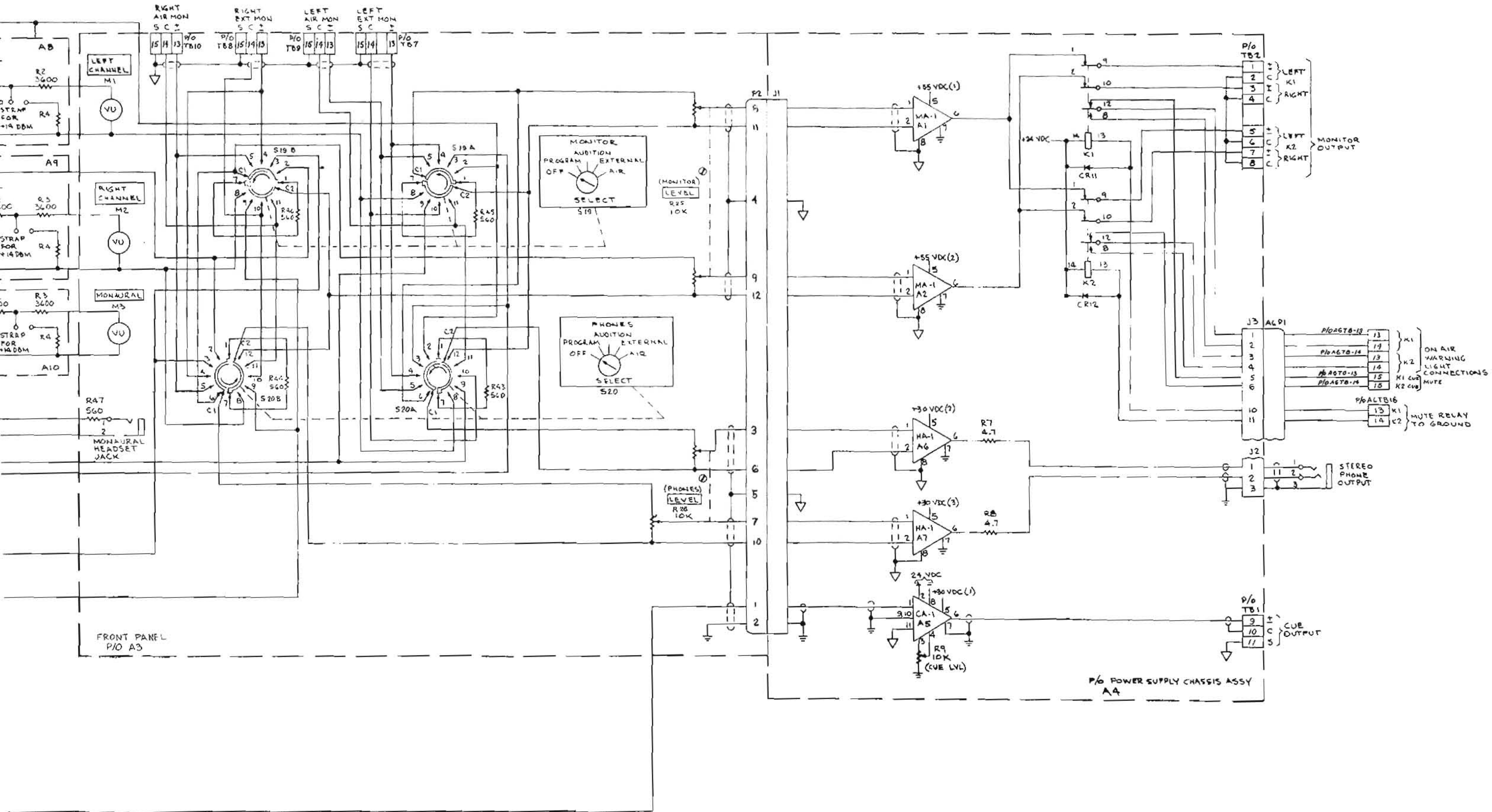
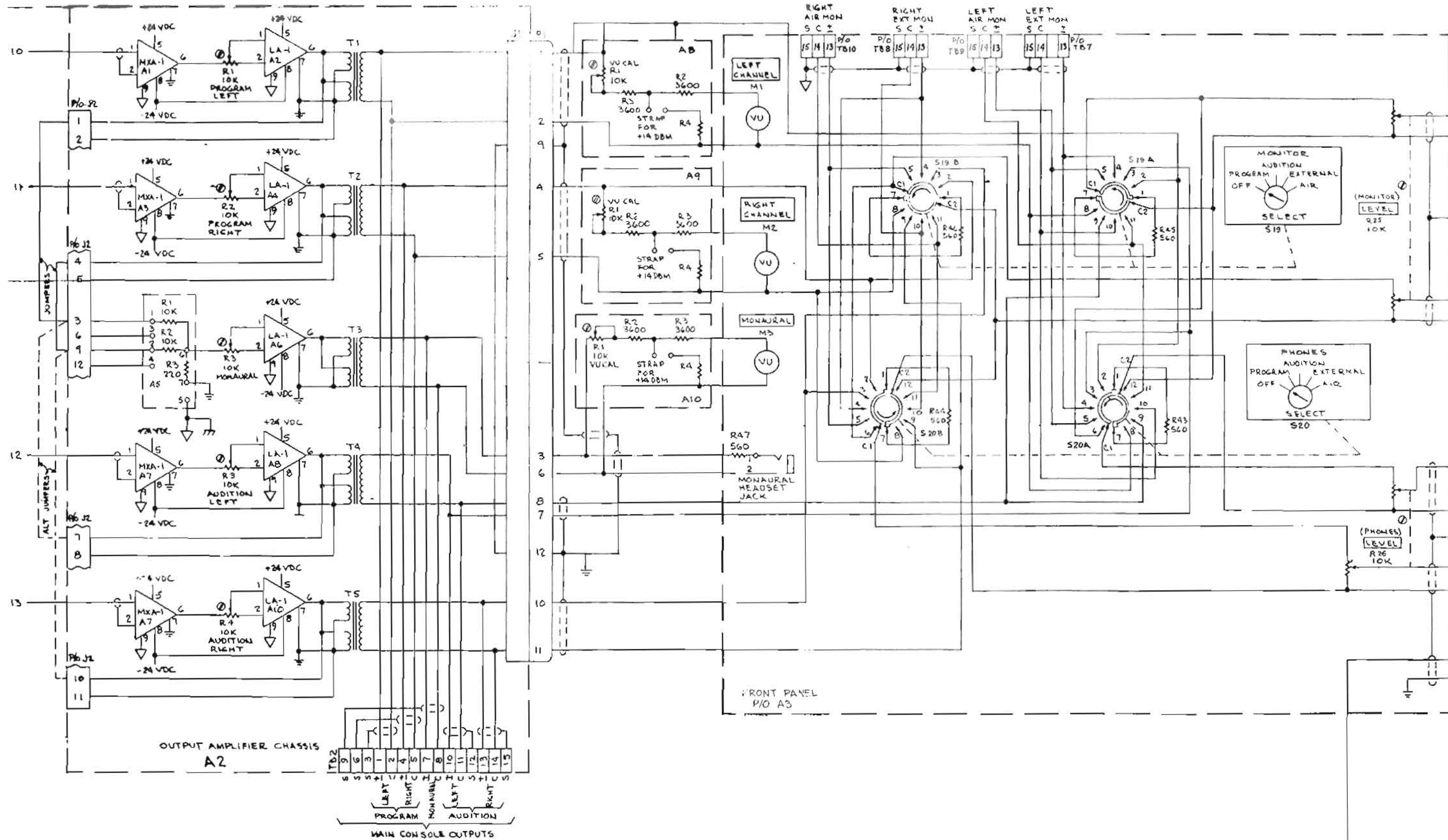

Figure 2 AC-8 Console Chassis, Schematic Diagram (Sheet 3 of 3).



parts list

SYMBOL	DESCRIPTION	MANUFACTURER'S PART NUMBER	MFR CODE	PART NUMBER
AC 8 CONSOLE				
A1	INPUT CHASSIS SEE BREAKDOWN			
A2	OUTPUT AMPLIFIER CHASSIS SEE BREAKDOWN			
A3	FRONT PANEL SEE BREAKDOWN			
A4	POWER SUPPLY CHASSIS ASSEMBLY SEE BREAKDOWN			
A5	INPUT TERMINAL BOARD CHASSIS SEE BREAKDOWN			
A6	OUTPUT TERMINAL BOARD ASSEMBLY SEE BREAKDOWN			
A7	MIXER NETWORK SEE BREAKDOWN			
A8	LEFT CHANNEL VU BOARD ASSEMBLY SEE BREAKDOWN			
A9	RIGHT CHANNEL VU BOARD ASSEMBLY SEE A8 FOR BREAKDOWN			
A10	MONAURAL VU BOARD ASSEMBLY SEE A8 FOR BREAKDOWN			
INPUT CHASSIS, A1				
A1 THROUGH A16	SELECT A1 THROUGH A16 FROM THE FOLLOWING  MATCHING TRANSFORMER BRIDGING TRANSFORMER JUMPER PLUG MICROPHONE PREAMPLIFIER	MT-1 BT-1 JP-1 MPA-1		124-0052-894 124-0052-893 124-0052-863 124-0052-855
R1	POTTEOMETER 1000 OHMS	70C4M032S102U	01121	
R2 THROUGH R8	SAME AS R1			
S1 S2 THROUGH S8	SWITCH  SAME AS S1	45206LR	82389	
XA1 XA2 THROUGH XA16	SOCKET, CONNECTOR  SAME AS XA1	77-MIT9T	03554	
OUTPUT AMPLIFIER CHASSIS, A2				
A1 A2 A3	MIXER AMPLIFIER LINE AMPLIFIER SAME AS A1	MXA-1 LA-1		124-0052-857 124-0052-858

SYMBOL	DESCRIPTION	MANUFACTURER'S PART NUMBER	MFR CODE	PART NUMBER
A4 A5 A6 A7 A8 A9 A10 J1 J2 P1 R1 R2 THROUGH R5 T1 T2 THROUGH T5 TB1 TB2 XA1 XA2 THROUGH XA10	SAME AS A2 MIXING PAD SAME AS A2 SAME AS A1 SAME AS A2 SAME AS A1 SAME AS A2 CONNECTOR, ELECTRICAL 12 CONTACTS SAME AS J1 CONNECTOR 12 CONTACTS POTENTIOMETER 10 KILOHMS SAME AS R1 TRANSFORMER SAME AS T1 NOT USED TERMINAL BLOCK CONNECTOR SOCKETS SAME AS XA1	250074-1      53312AB  P3312CCT  70A4M032S103A    027-0165   599-2004-15 77M1P9	AUTOG      10551  10651  01121    31740   75382 03554	
FRONT PANEL, A3				
AT1 AT2 THROUGH AT8  DS1 DS2 THROUGH DS6 M1 M2 M3 P1 P2 R1 R2 R3 R4 R5 R6 R7 R8 R9 R10 R11 R12 R13 R14 R15 R16 R17 R18 R19	ATTENUATOR SAME AS AT1  LAMP SAME AS DS1  METER, VU SAME AS M1 SAME AS M1 NOT USED CONNECTOR 12 CONTACTS RESISTOR 560 OHMS, 10% TOL, 1/2 WATT POTENTIOMETER 10 KILOHMS SAME AS R1 SAME AS R2 SAME AS R1 SAME AS R2 SAME AS R1 SAME AS R2 SAME AS R1 SAME AS R2 SAME AS R1 SAME AS R2 SAME AS R1 SAME AS R2 SAME AS R1 SAME AS R2 SAME AS R1 SAME AS R2 SAME AS R1	320Q2B3-A00-600   1819  561-200  P3312CCT  RCR20GF561KR  70C4N100S103A	28057   LEECR  LFECO  10551  81349  01121	

parts list

SYMBOL	DESCRIPTION	MANUFACTURER'S PART NUMBER	MFR CODE	PART NUMBER
R20	SAME AS R2			
R21	SAME AS R1			
R22	SAME AS R2			
R23	SAME AS R1			
R24	SAME AS R2			
R25	RESISTOR 560 OHMS, 10% TOL, 1/2 WATT	RCR20GF561KR	81349	
R26	POTENTIOMETER 10 KILOHMS	70C4N100S1D3A	01121	
R27	SAME AS R25			
R28	SAME AS R26			
R29	SAME AS R1			
R30	SAME AS R2			
R31	SAME AS R1			
R32	SAME AS R2			
S1	SWITCH	399433K	76854	
S2	SWITCH 24 CONTACTS	1E12763-1937	01548	
S3	SAME AS S1			
S4	SAME AS S2			
S5	SAME AS S1			
S6	SAME AS S2			
S7	SAME AS S1			
S8	SAME AS S2			
S9	SAME AS S1			
S10	SAME AS S2			
S11	SAME AS S1			
S12	SAME AS S2			
S13	SWITCH	399433K	76854	
S14	SWITCH 24 CONTACTS	1E12763-1937	01548	
S15	SAME AS S13			
S16	SAME AS S14			

SYMBOL	DESCRIPTION	MANUFACTURER'S PART NUMBER	MFR CODE	PART NUMBER
S21	SWITCH	4001	25435	
S22 THROUGH S28	SAME AS S21			
S19	SWITCH	399429K	76854	
S20	SAME AS S19			
S22	SWITCH	399431K	76854	
S23	SAME AS S22			
XDS1	LAMP SOCKET	7-20	LEEER	
XDS2 THROUGH XDS6	SAME AS XDS1			
	MISCELLANEDOUS PARTS			
	KNOB -QTY 8	RB67-4SKMLD	86797	281-0628-050
	KNOB -QTY 14	RB67-1SKMLD	86797	281-0628-020
POWER SUPPLY CHASSIS ASSEMBLY, A4				
A1	MONITOR AMPLIFIER	MA-1		124-0052-859
A2	SAME AS A1			
A3	POWER SUPPLY	PS-1		124-0052-862
A4	SAME AS A3			
A5	CUE AMPLIFIER	CA-1		124-0052-861
A6	HEADPHONE AMPLIFIER	HA-1		124-0052-860
A7	SAME AS A6			
C1	CAPACITOR 1100 UF, 50 VDCW	39D118G050HP4	56289	
C2	SAME AS C1			
C6	CAPACITOR 1000 UF, 75 VDCW	39D108G075JP4	56289	
C7	SAME AS C6			
C10	CAPACITOR 250 UF, 50 VDCW	TVA1312	56289	
C3	CAPACITOR 2200 UF, 25 VDCW	39D228G025HP4	56289	
C4	SAME AS C3			
C5	SAME AS C1			
C8	SAME AS C1			
C9	SAME AS C1			
C15	CAPACITOR 10 PF, 500 VDCW	DD100	99942	
C16	SAME AS C15			
CR1	DIODE	1N4005G	07688	
CR2 THROUGH CR 6	SAME AS CR1			
F1	FUSE, CARTRIDGE 2 AMPS, CURRENT RATING	MDL2	71400	
F2	FUSE, CARTRIDGE 1 AMP CURRENT RATING	AGC1	71400	
F3	SAME AS F2			
F4	FUSE, CARTRIDGE 2.5 AMPS CURRENT RATING	MDL2-1-5	71400	



parts list

SYMBOL	DESCRIPTION	MANUFACTURER'S PART NUMBER	MFR CODE	PART NUMBER
F5 F6 J1 J2 J3 K1 K2  L1 L2 R1 R2 THROUGH R6 R7 R8 R9  S1 T1 TB1 TB2 TB3 XF1 XF2 THROUGH XF6	SAME AS F2 SAME AS F2 CONNECTOR 12 CONTACTS SAME AS J1 SAME AS J1 RELAY SAME AS K1  INDUCTOR 10 UH SAME AS L1 RESISTOR 1 OHM, 5 WATTS  SAME AS R1  RESISTOR, FXD, COMPOSITION 4.7 OHMS, 10% TOL, 1 WATT SAME AS R7 POTENTIOMETER 10 KILOHMS  SWITCH TRANSFORMER TERMINAL BOARD TERMINAL BOARD SAME AS TB2 FUSEHOLDER  SAME AS XF1	  S3312AB      GPIR110200   8503  4530    RCR32G4R7KS   70A4M032S103A  8280K16 020-0417 599-2004-4 599-2004-15  342004-1	  10651      07389   16428  44655   81349   01121  27191 31740 75382 75382  75915	
INPUT TERMINAL BOARD CHASSIS, A5				
TB1 TB2 THROUGH TB12	TERMINAL BOARD  SAME AS TB1	599-2004-15	75382	
OUTPUT TERMINAL BOARD CHASSIS, A6				
TB1 THROUGH TB12 TB13 TB14 THROUGH TB16	NOT USED  TERMINAL BOARD  SAME AS TB13	   599-2004-15	   75382	

SYMBOL	DESCRIPTION	MANUFACTURER'S PART NUMBER	MFR CODE	PART NUMBER
MIXER NETWORK, A7				
R1	RESISTOR, FXD, COMPOSITION 10 KILOHMS, 5% TOL, 1/4 WATT	RCR07G103JR	81349	
R2 THROUGH R32	SAME AS R1			
LEFT CHANNEL VU BOARD ASSEMBLY, A8				
R1	POTENTIOMETER 10 KILOHMS	3007PL-103	80294	
R2	RESISTOR, FXD, COMPOSITION 3600 OHMS, 5% TOL, 1/2 WATT	RCR20GF362JR	81349	
R3	SAME AS R2			
MANUFACTURES CODES				
CODE	NAME AND ADDRESS			
AUTOG	AUTOGRAM 631 J PLACE P O BOX 454 PLANO, TX 75074			
LEECR	LEECRAFT MFG CO INC 21-16 44TH ROAD LI NEW YORK, NY 11101			
LFECO	LFE CORP, PROCESS CONTROL DIV 1601 TRIAPELO ROAD WALTHAM, MA 02154			
01121	ALLEN BRADLEY CO 1201 2ND ST MILWAUKEE, WI 53212			
01548	CAPITOL MACHINE AND SWITCH CO 87 NEWTOWN ROAD CANBURY, CT 06810			
03554	AMPHENDL CANADA LTD, DIV OF THE BUNKER RAMCO CORP 44 METROPOLITAN RD SCARBOROUGH ONTARIO, CANADA			
07389	CLAIR CORP 10085 WINDSTREAM DR COLUMBIA, MD 21043			
07688	MILITARY STANDARDS			
10651	VERNITRON CORP 175 COMMUNITY DR GREAT NECK, NY 11021			
16428	BELDEN CORP P O BOX 341 RICHMOND, IN 47374			

parts list

SYMBOL	DESCRIPTION	MANUFACTURER'S PART NUMBER	MFR CODE	PART NUMBER
25435	GRAYHILL HOLDTRONICS INC 703 ROGERS ST DOWNERS GROVE, IL 60515			
27191	CUTLER-HAMMER INC 4201 N 27TH ST MILWAUKEE, WI 53216			
28057	SHALL-CO INC HIGHWAY 301 SDUTH P O BOX 55 SMITHFIELD, NC 27577			
31740	LEIGHTNER ELECTRONICS INC P O BOX 314 PLANO, TX 75074			
44655	DHMITTE MFG CO 3601 W HOWARD ST SKOKIE, IL 60076			
56289	SPRAGUE ELECTRIC CO NORTH ADAMS, MA 01247			
71400	BUSSMANN MFG, DIV OF MCFRAW-EDISON CO 2536 W UNIVERSITY ST ST LOUIS, MO 63017			
75382	KULKA ELECTRIC CORP 633-643 S FULTON AVE MT VERNON, NY 10550			
75915	LITTLEFUSE INC 800 E NORTHWEST HWY DES PLAINES, IL 60016			
76854	OAK MFG CO S MAIN ST CRYSTAL LAKE, IL 60014			
80294	BOURNS INC 1200 COLUMBIA AVE RIVERSIDE, CA 92507			
81349	MILITARY STANDARDS			
82389	SWITCHCRAFT INC 5555 N ELSTON AVE CHICAGO, IL 60630			
86797	ROGAN BROS INC 8031 N MONTICELLO SKOKIE, IL 60076			
99942	CENTRALAB SEMICONDUCTOR 4501 N ARDEN DR EL MONTE, CA 91734			

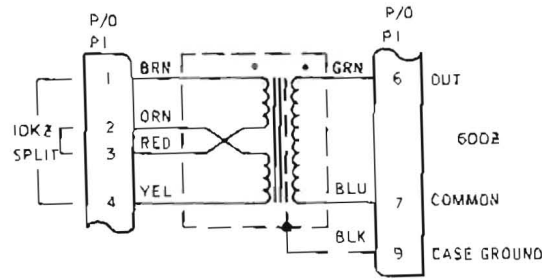
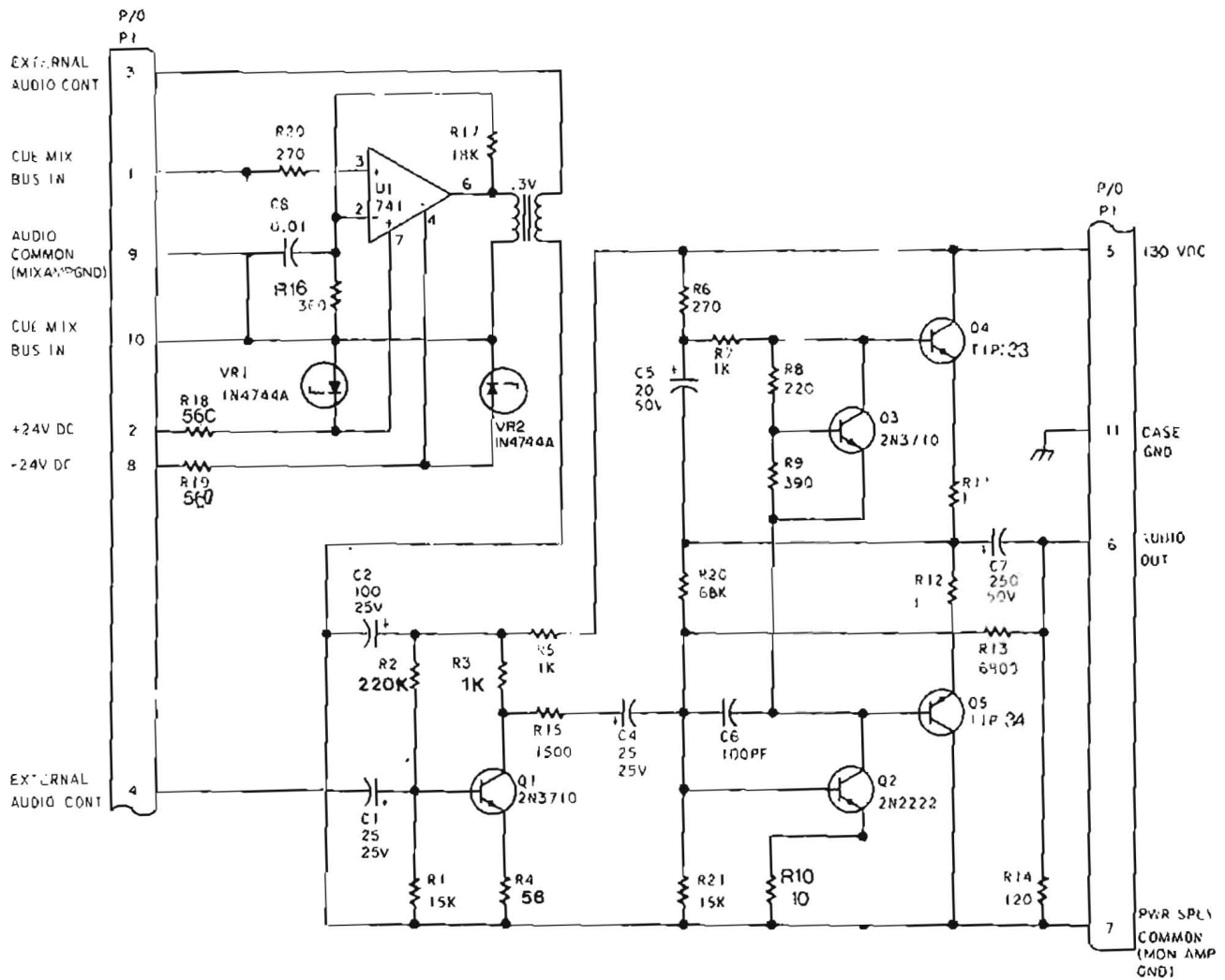
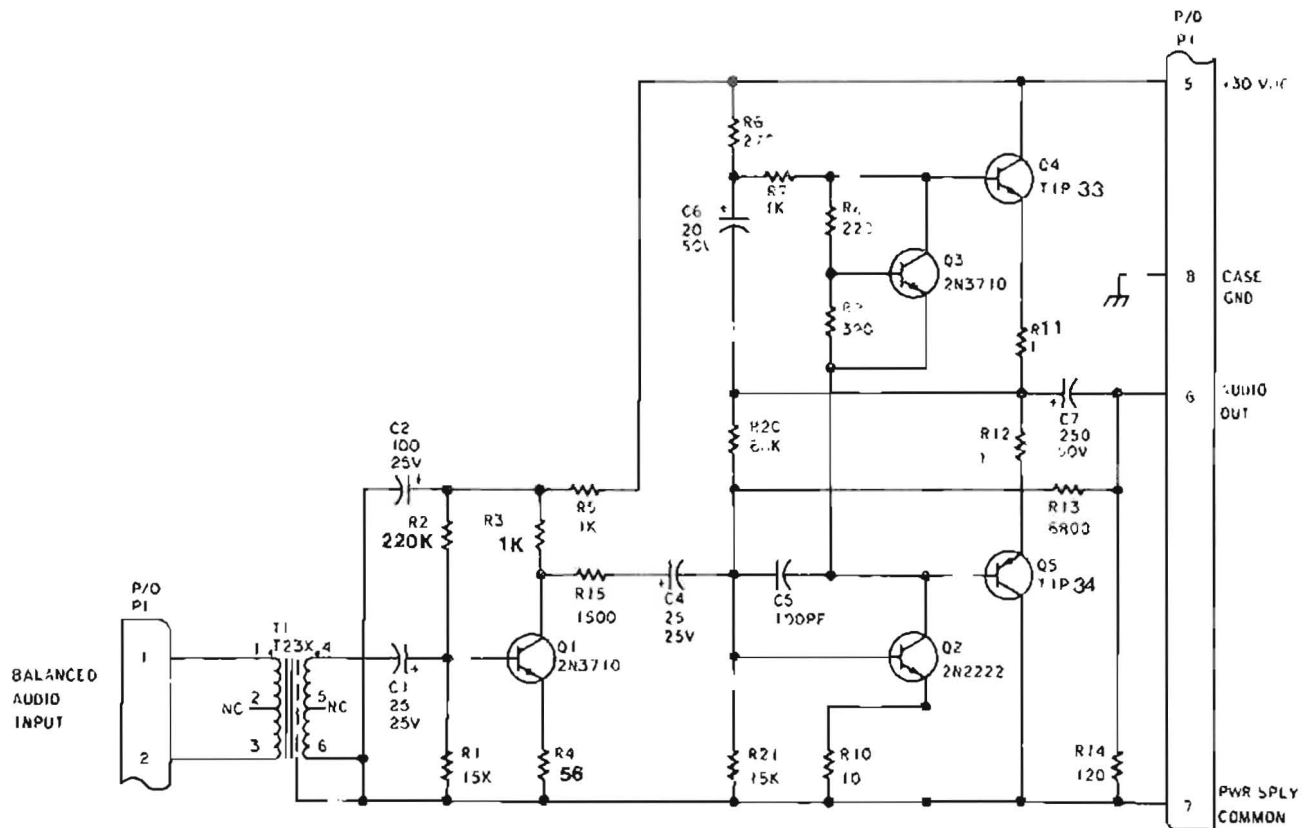

Figure 3. Bridging Transformer BT-1, Schematic Diagram.



- NOTES:
1. UNLESS OTHERWISE SPECIFIED ALL RESISTANCE VALUES ARE IN OHMS, ALL CAPACITANCE VALUES ARE IN MICROFARADS.

Figure 4. Cue Amplifier CA-1, Schematic Diagram.



NOTES:  
 1. UNLESS OTHERWISE SPECIFIED  
 ALL RESISTANCE VALUES ARE IN OHMS.  
 ALL CAPACITANCE VALUES ARE IN MICROFARADS.

Figure 5. Headphone Amplifier HA-1, Schematic Diagram.

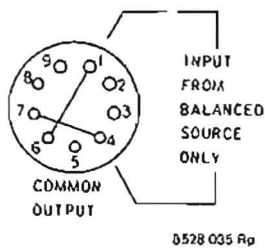
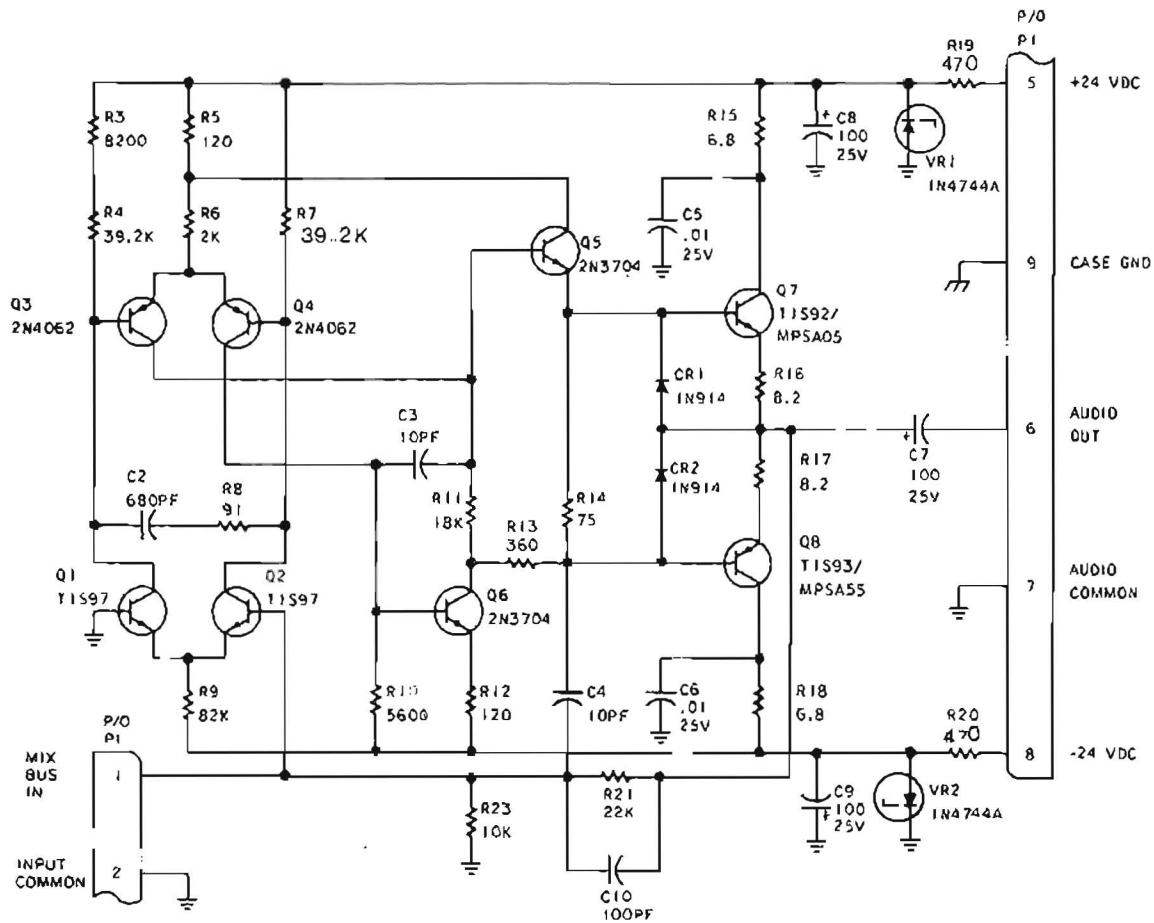

Figure 6. Jumper Plug JP-1, Schematic Diagram.



NOTES:  
 1. UNLESS OTHERWISE SPECIFIED  
 ALL RESISTANCE VALUES ARE IN OHMS  
 ALL CAPACITANCE VALUES ARE IN MICROFARADS

Figure 7 Mixer Amplifier MXA-1, Schematic Diagram.

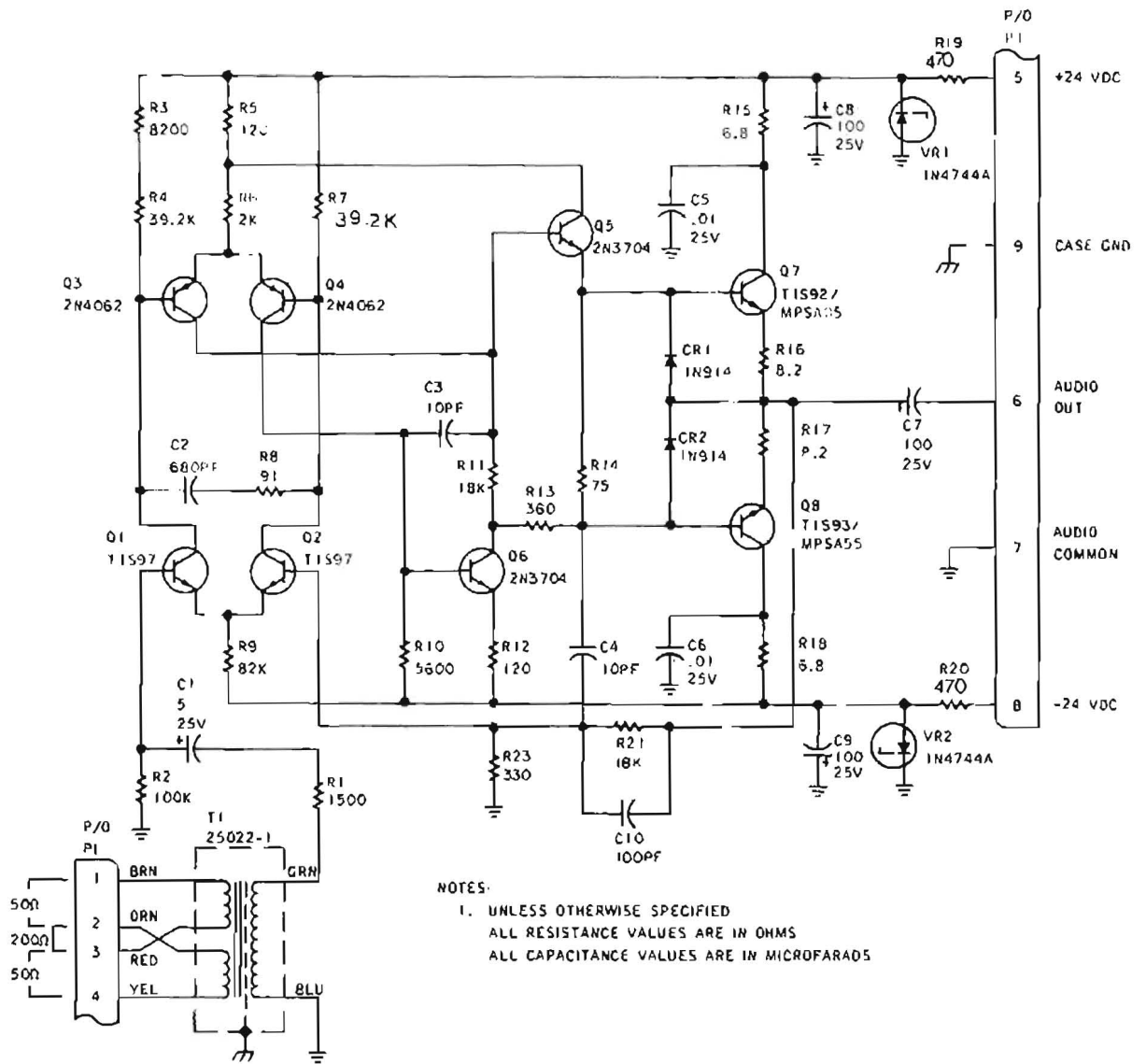

Figure 8 Microphone Preamplifier MPA-1, Schematic Diagram.

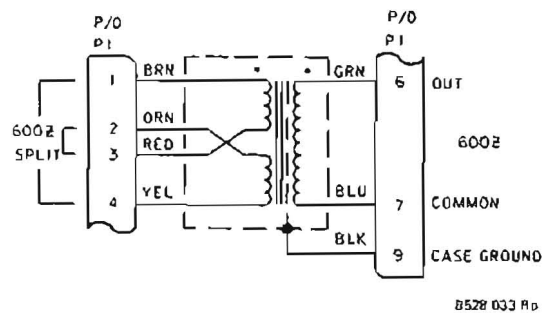

Figure 9 Matching Transformer MT-1, Schematic Diagram.

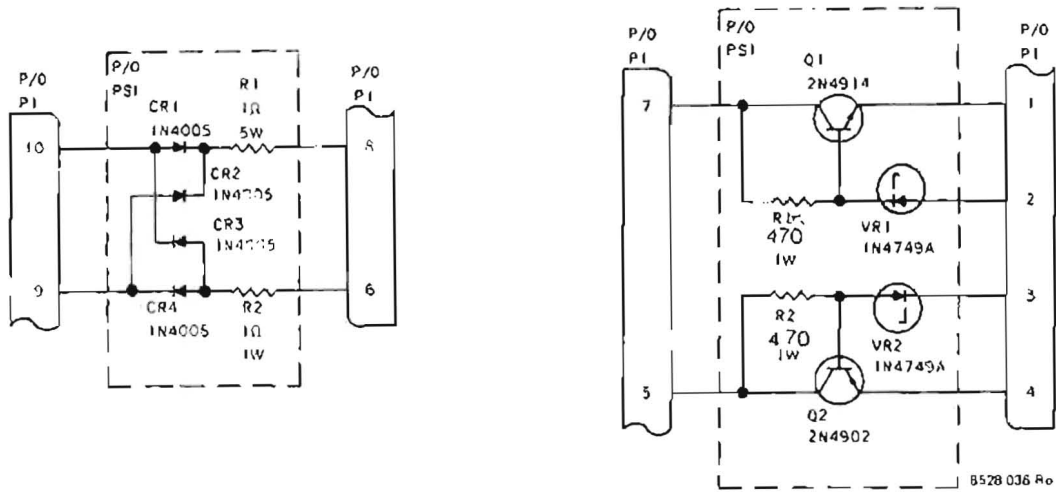
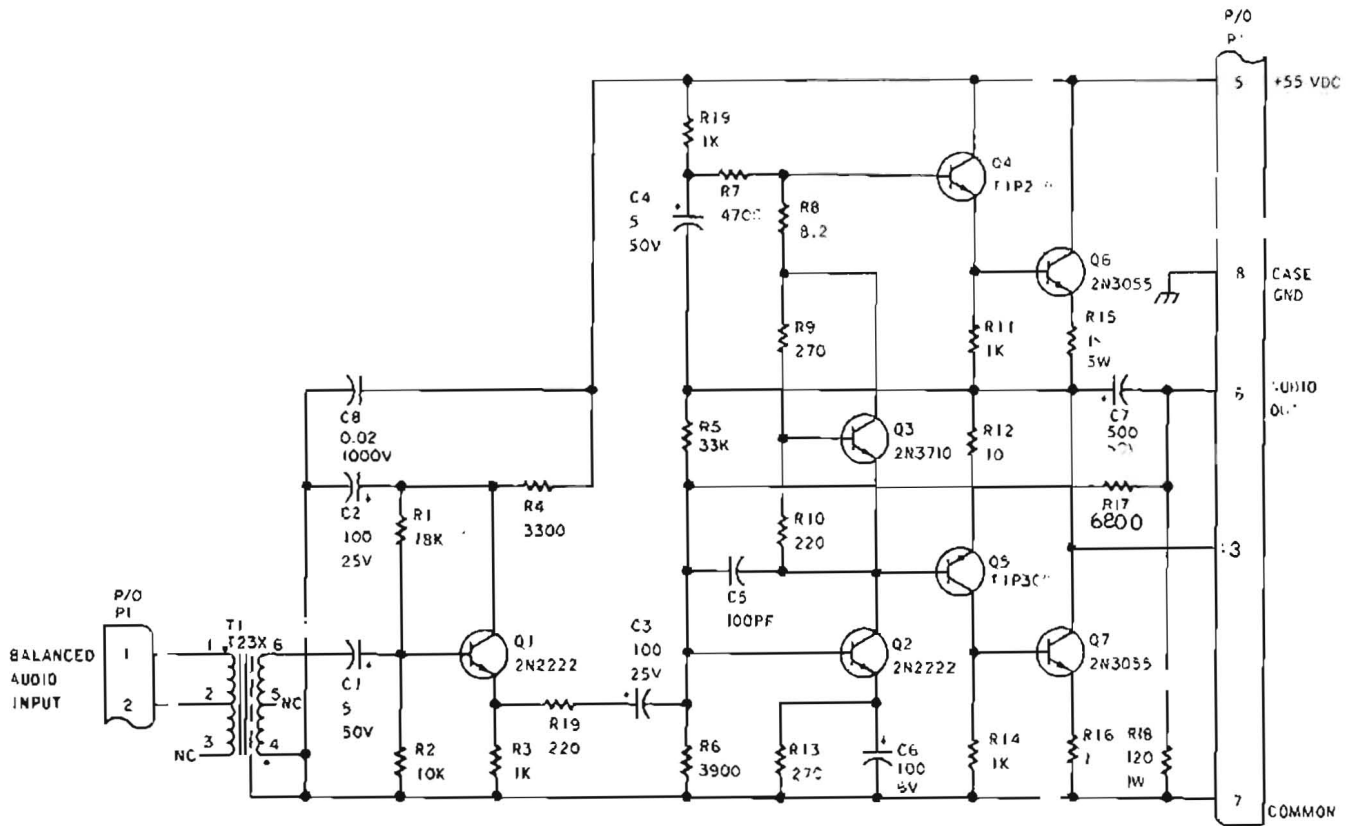

Figure 10 Power Supply PS1, Schematic Diagram.



NOTES:  
 1. UNLESS OTHERWISE SPECIFIED  
 ALL RESISTANCE VALUES ARE IN OHMS.  
 ALL CAPACITANCE VALUES ARE IN MICROFARADS.

Figure 11 Monitor Amplifier MA-1, Schematic Diagram.



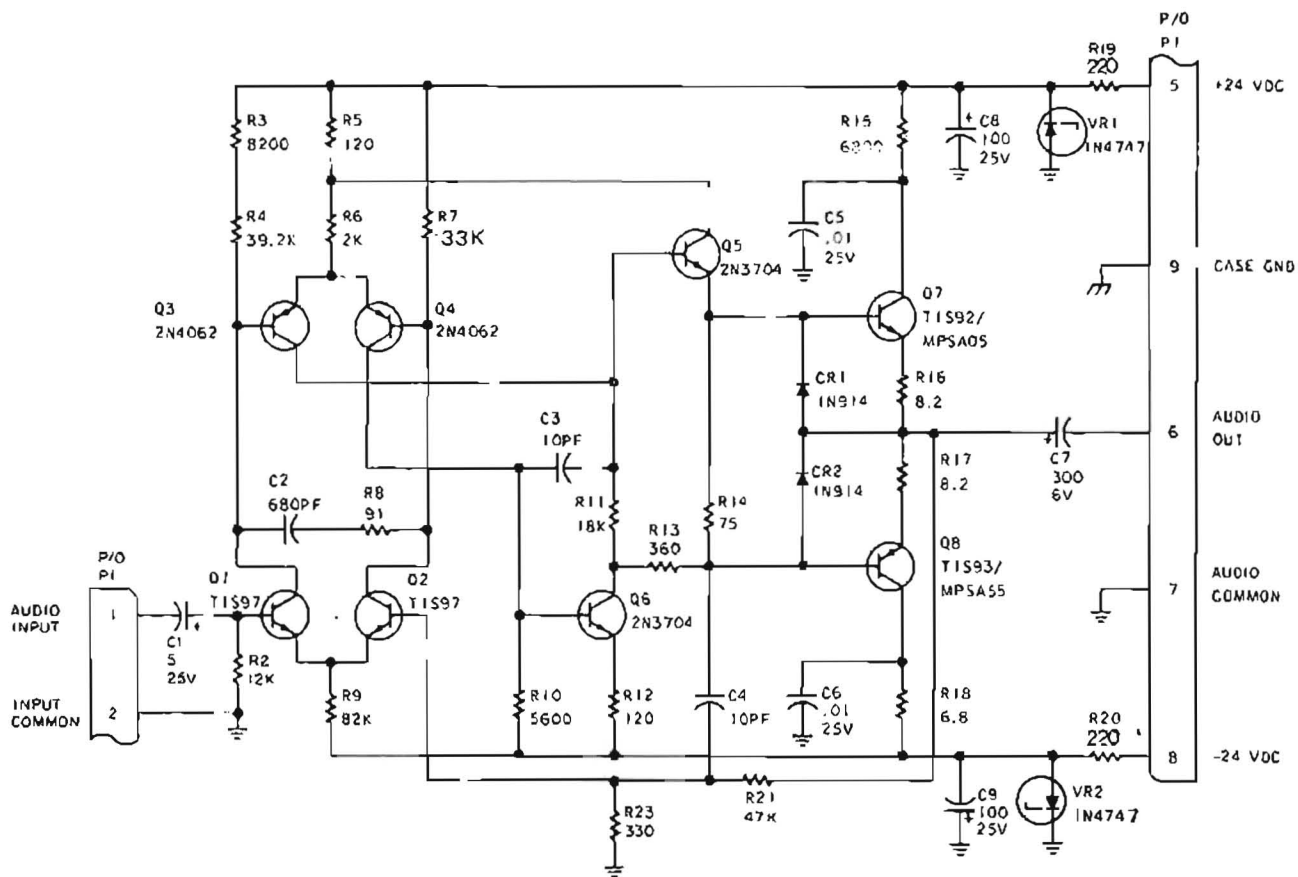

NOTES:  
 1. UNLESS OTHERWISE SPECIFIED  
 ALL RESISTANCE VALUES ARE IN OHMS  
 ALL CAPACITANCE VALUES ARE IN MICROFARADS

Figure 12 Line Amplifier LA-1, Schematic Diagram.  
 26