

the

COMPELLOR™



OWNER'S MANUAL

from **APHEX SYSTEMS LTD.**

THE COMPELLOR

TABLE OF CONTENTS

1.0	INTRODUCTION	1
2.0	CONTROL CIRCUITS	2
	2.1 The DVG	
	2.2 The DRC	
	2.3 The Silence Gate	
	2.4 Stereo Enhance	
3.0	METERING	3
4.0	FUNCTIONAL DESCRIPTION	4
5.0	APPLICATIONS	
	5.1 BROADCASTING	6
	a) Pre-Processing	
	b) STL/Phone Line Drive	
	c) Carting/Tape Duplication	
	d) Mic Processing	
	5.2 RECORDING AND MIXING	
	a) Tracking	
	b) Mixing	
	c) Single Channel Use	
	d) Mastering	
	5.3 SOUND REINFORCEMENT	7
	5.4 FILM DUBBING	7
6.0	INSTALLING THE COMPELLOR	9
	6.1 MOUNTING	
	6.2 CONNECTORS	
	6.3 IMPEDANCES	
	a) Inputs	
	b) Outputs	
	6.4 NOMINAL LEVEL SETS	
	6.5 AC LINE CONNECTOR	
7.0	COMPELLOR OPERATING INSTRUCTIONS	11
	7.1 PREFACE	
	7.2 OPERATION	
8.0	TECHNICAL DESCRIPTION	13
	8.1 INPUT CIRCUIT	
	8.2 VCatt STAGE	
	8.3 OUTPUT STAGE	
	8.4 PEAK LIMITER	
	8.5 LEVELING SIDCHAIN	

8.6	COMPRESSION SIDECHAIN	
8.7	DYNAMIC VERIFICATION GATE	
8.8	SILENCE GATE	
8.9	STEREO ENHANCE	
9.0	COMPELLOR TEST PROCEDURES	19
	9.1 COMPRESSION TEST	
	9.2 LEVELING TEST	
	9.3 PEAK LIMIT TEST	
	9.4 ADDENDUM	
10.0	DISSASSEMBLY GUIDE and MECHANICAL PARTS LIST	24
11.0	BLOCK DIAGRAM	25
12.0	SCHEMATICS AND PARTS LISTS	26
	12.1 I/O SECTION	
	12.2 CONTROL AND DISPLAY CIRCUITS	
	12.3 POWER SUPPLY	
13.0	SPECIFICATIONS	34
14.0	WARRANTY AND SERVICE INFORMATION	36
15.0	ADDENDA	37

THE COMPELLOR

1.0 INTRODUCTION

The COMPELLOR tm is a unique combination of compressor, leveler, and peak limiter. The three detector circuits feed a single gain control device per channel in a very simple, high quality audio path of extraordinary transparency. (See block diagram). The compression and leveling sidechains are "intelligent", being program controlled and interactive. The result is a very simple, easy to use device that is free of the sonic problems commonly associated with gain reduction such as pumping, breathing, noise build up, popping and hole punching.

All three functions are designed to work together using feed back techniques (reading the OUTPUT of the VCAtt) for extremely low distortion and accurate operation. The leveler provides a "platform" based on long term average levels. The compressor, working from this "platform" has to do less gain reduction and can more easily handle short term level changes. A process balance control varies the proportions of compression and leveling. The high speed (1usec) limiter catches any dynamic overshoots and ensures an absolute ceiling. The limiter also allows the compressor action to remain slow enough to maintain natural transient qualities in the audio. To illustrate the co-functioning of the three systems, imagine a sudden 20 dB increase in signal level above 0 VU. The limiter will catch the peak and hold it, if necessary, until the compressor reduces the level. If the increase is maintained, the leveler will then further reduce gain, freeing the compressor.

With even the best and most modern gain control devices one can only imagine the quantity of controls necessary to handle such severe and complex dynamic changes while avoiding sonic degradation. Even if a proper setting could be found, it would only be optimized for one audio texture and level, necessitating constant control changes to maintain audio quality. The COMPELLOR's control circuits have the "intelligence" to analyze the incoming audio and make all the control changes automatically on a real-time basis, resulting in inaudible, continually optimized dynamic range control.

2.0 THE CONTROL CIRCUITS

Two of the most important parts of the control circuitry are the proprietary Dynamic Verification Gate TM (DVG) and the Dynamic Recovery Computer TM (DRC).

The DVG monitors short term and long term average levels, compares them, and impedes gain changes when program dynamics might be sacrificed for arbitrary gain reduction. The DVG also prevents gain release during short term program pauses which otherwise would cause "pumping" or "breathing" effects. Vocal material is especially benefited by this feature, sounding natural even when extremely compressed. DVG action is indicated by a front panel LED.

The DRC allows very rapid recovery from gain reduction under certain complex wave conditions. Signals that are high in peak amplitude but low in relative power cause an increase in the compression release rate. Unrequired gain reduction is thus inhibited, preventing loss of transient wavefronts, holes, etc. This contributes towards a natural, open sound, even during heavy compression.

The Silence Gate is another important part of the COMPELLOR's natural sound. Whenever the input falls below the selected threshold the Silence Gate freezes release of the gain reduction. This eliminates noise swells and allows normal fade-outs. When the program resumes, attack is improved on the next signal because gain reduction does not now have to go full range. The Silence Gate will hold gain reduction release indefinitely--for several hours, if necessary. The threshold is set by a front panel knob and is variable between 0 and -40 dBv.

A special feature incorporated into the Compellor is Stereo Enhance. This is not an audio matrixing system or a stereo synthesizer. It works by modulating the gain in each channel based on difference information in the input. It creates a subtle, pleasant widening of the stereo image. It is fully mono compatible, creates no center hole or build-up and has no effect on mono (or hard left, right or center) material.

3.0 METERING

The COMPELLOR has a unique multifunction, bi-color LED metering system designed to put all operational information at your fingertips.

In the PROGRAM mode the meters function as two-color bargraphs and can be switched between input and output levels. The red bar indicates average level (VU) and the green above it shows peak level. Program dynamics and density can be seen at a glance.

In the PROCESS mode the meter shows the total amount of gain reduction as a green bar. A single red dot indicates the amount of leveling. The green bar above the red dot indicates the amount of compression. For example, if 16dB of total gain reduction is indicated and the red dot is at 10dB, 6dB of compression above 10dB of leveling is indicated.

A yellow "DVG" LED at the beginning of each meter flashes when the DVG is working. At the end of each meter is a red "LMT" LED which flashes when the Limiter is operating.

Above the IN/OUT switch is a bi-color LED which is red when the unit is in circuit and green when the unit is in relay bypass.

The SILENCE GATE has a yellow LED above the threshold knob. When lit, it indicates that the Silence Gate has frozen gain reduction release.

STEREO ENHANCE operation is indicated by a green LED above the Stereo Enhance switch.

4.0 FUNCTIONAL DESCRIPTION

The input and output circuits are transformerless. Unique, special circuits were developed for use in the COMPELLOR to allow it to be interfaced with a wide range of audio systems. The Compellor can be driven from balanced or unbalanced sources as if it had a Gridging type input transformer. The common mode rejection is excellent and RFI filtering is employed.

The nominal operating level (OVU) of the input circuit can be set by internal jumpers for -10,0,+4,or+8 dBm levels. Since the Compellor operates at a constant internal level, the input metering automatically follows.

The next audio stage is the patented Aphex 1537A VCA circuit. This Class A device is acknowledged to be the best gain control circuit available.

The output circuit is a unique active type which can be used like a transformer winding. If one of the outputs is grounded, full voltage swing is transferred to the opposite side of the balanced output. Gain and drive are thus preserved for unbalanced loads. Like the input circuit, the output can be tailored to -10,0,+4, or +8dBm operating levels. The input and output levels may be set differently so that the Compellor may be used as a level translator. The maximum output level is +27dBm balanced and +21dBm unbalanced.

The COMPELLOR's compression level detector is influenced not only by the RMS level of the audio, but also by program dynamics and wave complexity, so audio quality is greatly enhanced over simple RMS or average responding processors. Transient sounds are preserved, pumping and breathing eliminated, etc. It has a "soft knee" compression characteristic, with the ratio varying from 1.1:1 at threshold (30 dB below nominal OVU), increasing to 20:1 at OVU. The attack and release times are automatically varied, 5-50mSec(attack) and 200mSec-1 Sec (release).

The leveling process provides a slow and smooth control over the program level platform. It has a fairly steep ratio (20:1) and the variable attack and release times simulate the way the ear perceives loudness over long periods. It varies around 2.5 Sec attack and 5 Sec release. It's most useful purpose is to maintain a consistent compression depth (and therefore quality) regardless of the program input level.

The peak limiter has a fixed threshold 12 dB above nominal OVU with an attack time of 1 uSec and release time of 10 mSec. The 12dB ceiling was carefully chosen to allow maximum cooperation between the sidechains, providing natural sounding peak characteristics while maintaining a strong average level. This ensures maximum drive level to following devices without fear of clipping, overmodulation, or tape saturation.

The last circuit controlling the VCA is the input level control. Turning the knob counterclockwise attenuates the VCA, thus reducing processing. Turning the control clockwise opens up the VCA, sending

more signal to the output and the detectors, providing more processing.

5.0 APPLICATIONS

5.1 BROADCASTING

a) Pre-Processing

Most other processors have a 'sweet spot' in which they work best, usually with minimum amounts of gain reduction. The COMPELLOR will drive the audio consistently into that spot, making a station practically 'jock proof'. By taking the burden of heavy gain reduction off of following devices (especially limiters) the devices can do what they do best, with minimum negative effect on the audio quality.

For example, the COMPELLOR can be set to feed a steady average input level with controlled dynamics into a multiband processor or clipper which can then be adjusted to work only on the extreme peaks without fear of overload. The result is equal or greater loudness but with a much cleaner, more natural sound.

b) STL/Phone Line Drive

Maintaining consistent drive levels while controlling peaks (without overshoot and ringing) is just another way of describing the COMPELLOR. Full modulation of the STL can be sustained without concern for overload. Audio level can be kept well above the noise floor of phone lines or STL without the possibility of crashing anything following the COMPELLOR.

c) Carting/Tape Duplication Varying audio levels from cart to cart is an all too typical problem. With the COMPELLOR, levels can be easily maintained while recording to assure maximum signal to noise performance without tape saturation. The COMPELLOR is especially useful in assembling tapes from several sources with varying levels onto a single tape.

d) Mic Processing

One of the most difficult signals a processor encounters is the human voice. The COMPELLOR works beautifully on voice by producing a dense, 'punchy' sound while retaining dynamic and transient qualities. The apparent level will be consistent without changing the urgency and excitement of a screaming DJ or altering the intimacy of a soft-spoken female voice.

5.2 RECORDING AND MIXING

a) Tracking

Getting the maximum level on tape before saturation and high above the noise floor without any sonic degradation is the goal of all recordists. Unfortunately, not too many artists have perfect mic technique. As a result the recordist must ride faders as best he can and fix what was missed in the mix, if possible. The COMPELLOR makes the recordist's job easier; all that he must do is set the dynamic 'tightness' and output level.

Another advantage of using the COMPELLOR over other compressor/limiters is that it will not reduce high frequencies or increase sibilance. This reduces the need for equalization and

de-essing, making the job easier and the recording cleaner.

b) Mixing

Making a track or sub-mix 'sit' in a mix requires either riding a fader or using gain reduction. The COMPELLOR, again, gives perfect, hands-off control.

c) Single Channel Use

It should be noted that although the audio channels are completely discrete, there are shared control circuits. Leveling is tied to preserve stereo imaging, and follows the channel with the highest input level. To avoid possible problems when processing two unrelated tracks such as voice and piano, use the COMPELLOR in pure compression mode.

Also, when using the COMPELLOR for two unrelated tracks, if the silence gate detects a signal above threshold level in either channel it will allow gain reduction release in both.

d) Mastering

Mastering using the COMPELLOR is different than using conventional over-threshold limiters. A limiter will catch only peaks (very often at the expense of sound quality) but will retain most of the existing dynamic range. The COMPELLOR will also catch peaks (without any sonic degradation) but may tend to change high to low level balances if much compression/leveling is used. However, since the COMPELLOR's action is inaudible, a further 'tightening' of the dynamic range may be applied at this point, pleasingly increasing 'punch' and density.

5.3 SOUND REINFORCEMENT

Being able to control dynamics is even more critical in live situations since there is no way to fix it later. The COMPELLOR allows perfect placement of a mic or sub-mix simply and easily. Background vocals stay in the background without getting lost, lead vocals remain strong and clear. Using the COMPELLOR on the full program provides sonically transparent protection for amplifiers and speakers, while maintaining a more consistent average level, thus providing a more pleasing performance.

In monitoring systems the COMPELLOR sustains maximum level before feedback.

Churches, Conference Rooms and other large venues will benefit by the COMPELLOR's ability to keep a steady output regardless of the levels of different sources, or the varying level of a single source (e.g. - a preacher walking around a microphone).

5.4 FILM DUBBING

Matching levels between multiple sources is often a job which requires more than one person to ride gain and switch sources at the appropriate times. The COMPELLOR makes the job much easier. It is especially effective on optical soundtracks which are so sensitive to any peak overload. Attention must be given, however, to the modulation of the noise floor which, in this application, can be quite high if extreme gain reduction is used.

6.0 INSTALLING THE COMPELLOR

6.1 MOUNTING

The COMPELLOR is designed to mount in a standard 19" rack, occupying 1 rack space (1 3/4").

6.2 CONNECTORS

Inputs and outputs are made via standard XLR connectors. As both input and output stages emulate transformers, American (pin 3 hi) or European (pin 2 hi) may be used interchangeably. It is important that the same standard be used at both input and output.

6.3 IMPEDANCES

a) Inputs

The input impedance to the COMPELLOR is 50K Ohm balanced, 25K Ohms unbalanced. This should allow the COMPELLOR to be easily driven by any other piece of audio equipment, including consumer gear. However, some outputs are designed to work into a 600 ohm load and will show unusually low output meter readings while properly driving the COMPELLOR, or will considerably overdrive the COMPELLOR's input while indicating OVU. In either case there will be a large disparity between indicated drive levels, the COMPELLOR's meters reading much higher than the output meter of the driving unit. Should this happen, a resistor must be installed across the COMPELLOR drive lines to lower the input impedance to 600 ohms.

b) Outputs

The output impedance of the COMPELLOR is very low, (20 Ohms balanced, 10 Ohms unbalanced) again to easily drive almost any load. However there are some types of inputs, especially transformer types, that are designed to see a 600 Ohm source impedance. An indication of this mismatch would be a non-linear frequency response, emphasizing the low frequencies.

The solution is to terminate the output of the COMPELLOR with 300 Ohm, 1 watt resistors in series with the balanced outputs.

6.4 NOMINAL LEVEL SETS

In order to be used with any audio system, the COMPELLOR's nominal operating level can be internally adjusted from -10 to +8dBm. This optimizes signal-to-noise performance and headroom, and also enables the COMPELLOR's meters to match the system in which it's being used.

The input and output levels are individually set on each audio (lower) board by means of DIP jumpers. (See diagram, and disassembly instructions).

Input and output levels may be set separately to use the COMPELLOR as a level interface if necessary. For example, it can be fed from a -10dBm source (CD or tape player) and feed a +4dBm system, interfacing properly with both.

6.5 AC LINE CONNECTORS

The COMPELLOR is designed to operate from line voltages from 90-250 volts 50-60 Hz, at 20 watts. The operating voltage is easily adjusted by inserting the card in the AC receptacle on the rear with the desired voltage readable.

ACTUAL LINE VOLTAGE	SET SELECTOR FOR
90 - 110 VAC	100 V
110 - 130 VAC	120 V
210 - 230 VAC	220 V
220 - 250 VAC	240 V

Apply AC power, switch the COMPELLOR 'ON'. A variety of indicators should appear on the front panel.

7.0 COMPELLOR OPERATING INSTRUCTIONS

7.1 Preface

The COMPELLOR is ideal for any application requiring dynamic range control. Other devices either degrade audio quality, and/or need constant adjustment, thus prohibiting their use for many applications. The COMPELLOR has no audible effect other than level control. The user simply determines how 'tight' a dynamic range is required and the COMPELLOR does the rest, automatically controlling its operating parameters in response to varying program material.

The 'tightness' of the dynamic range (the relationship between the highest and lowest levels) is set by using the INPUT and the PROCESS BALANCE controls.

As mentioned in the functional description, the compressor's ratio is variable from 1.1:1 to 20:1 and has faster attack and release than the leveler. Therefore, as the PROCESS BALANCE knob is moved more toward compression, the 'tighter' the dynamic range (Note: Even with more than 20dB of pure compression the signal will still not sound "squashed").

The leveler, having a fixed ratio, maintains a 'platform' for the compressor, holding a constant amount of compression regardless of input level changes. As the PROCESS BALANCE knob is moved more toward leveling, the instantaneous dynamic range becomes less controlled. If the leveler is used without any compression at all, there may be some 'breathing' or 'swelling' due to the very slow attack and release.

The INPUT knob affects the total amount of gain reduction. Once you have chosen the setting of the PROCESS BALANCE (12 o'clock is a good starting point) adjust the INPUT control to give the desired amount of gain reduction. For example, 10dB of leveling is sufficient to handle broad program level changes.

Once you have set the total amount of gain reduction, use the OUTPUT control to achieve the desired output level. Depending upon the 'tightness' of the dynamic range as set by the INPUT and PROCESS BALANCE controls, the long term average output of the COMPELLOR will remain close to the set level.

7.2 Operation

- a) Begin with the IN/OUT switch in the OUT (green LED) position.
- b) With METER SELECT switches in PROGRAM and INPUT modes, the input on the COMPELLOR meter should match the output of the device that is driving the COMPELLOR. If not, you may have to change the nominal operating levels in the COMPELLOR.
- c) Adjust the PROCESS BALANCE knob for the desired ratio of compression to leveling. The center, or 50/50 position is a good starting place for most applications.
- d) With the metering in the GAIN REDUCTION mode, adjust the INPUT

knob to achieve the desired amount of total gain reduction. (See previous meter section). Note - If the INPUT knob is fully clockwise and more gain reduction is desired, either increase the input level to the COMPELLOR, or re-set the input operating level jumpers inside the COMPELLOR to a lower level.

e) With the metering in the PROGRAM/OUTPUT mode adjust the output level, usually unity gain on peak level.

f) Set the SILENCE GATE threshold so that it is below the lowest signal that should be processed (allow for fade-outs), and above the input noise level.

g) Engage the IN/OUT switch so that the LED is Red (COMPELLOR now 'in').

h) Re-adjust the controls to achieve the desired 'tightness' and output level as necessary.

8.0 TECHNICAL DESCRIPTION

It will be helpful to refer to the Block diagram when identifying the functional circuits. The schematics will be referenced in the following discussion.

8.1 INPUT CIRCUIT

A specialized instrumentation amplifier is used to provide true differential gain, optimum overload characteristics, differential VCA drive, and high common mode rejection over a wide bandwidth. RFI filtering as provided using a ferrite core technique, with additional filtering as an inherent characteristic of the input stage circuit.

Refer to the Audio I/O schematic. The input circuit centers around U101A&B, and U102A. U101A&B are much like a traditional instrumentation amplifier. In this application, the output is utilized to drive the VCA circuit. Input gain normalizing is selected by the user to match the system operating level by changing a resistor in the feedback circuit, thus determining the operating gain of the input stage. A very unique arrangement is incorporated in this input circuit using U102A as a common mode error cancellation amplifier. Via R115 and R113, U102A responds only to the signal which is not equal and out of phase between the outputs of U101A&B. U102A is operated with high gain.

At the input to U101A&B, note resistors R103, R104, R105, and R106 forming a bridge. This bridge sums the input signal with the common mode error signal from U102A. Effectively, any common mode input signal will thus be cancelled out, eliminating it from appearing at the differential output of the input circuit. Capacitors C103 and C104 act as DC blockers in case the input source might contain some DC offset. C105, C106, and C110 produce a phase correcting effect which guarantees stability of the system at high frequencies. Also, C105 and C106 form part of a low pass filter at the input which rejects RFI frequencies. Primary RFI filtering is obtained through the ferrite RF transformer core input choke, in conjunction with bypass capacitors C101 and C102.

It is important to observe that this input circuit maintains high speed and near ideal characteristics because of its perfect symmetry with both polarities passing through identical paths, and each path being operated with optimized noise and headroom parameters.

Due to the error correcting "servo" type of feedback employed through U102A, the input can be driven unbalanced with equal gain and differential drive to the VCAtt being the result. In other words, the input stage automatically adjusts its own input sensing to accept either balanced differential, or unbalanced inputs, and produces the same net gain. This is directly analogous to using an electromagnetic transformer input stage, but without the drawbacks of audio degradation caused by transformers.

8.2 THE VCatt STAGE

The COMPELLOR incorporates the Aphex 1537A Voltage Controlled Attenuator as the heart of the gain management system. U103A&B form a pair of linearized current sources (in conjunction with the VCatt device, U104). The VCatt is operated balanced, differentially, to obtain maximum headroom and minimum distortion characteristics. Differential output summing is performed by U105A. A net gain is realized due to gain which is taken in the summing output amplifier. Therefore, the system is actually operated as a voltage controlled amplifier which exhibits a net gain with zero control volts. The gain through the input stage and VCatt is chosen to produce adequate peak headroom through the system under maximum drive, maximum gain reduction conditions, which are worst case in terms of requisite dynamic range of the electronics.

Pin 8 of U104 accepts the DC gain control voltage. Two voltages are resistively summed at pin 8. R135 injects control voltage from the peak limiter buffer/driver U108B. R134 injects a composite control voltage consisting of compression and leveling drive from summing amplifier U105B. Resistive summing is used at pin 8 in order to maintain the fastest possible response with minimum delay for the peak limiter control injection.

8.3 OUTPUT STAGE

The COMPELLOR output stage is a highly refined balanced differential line driver having transformer output characteristics in terms of amplitude regulation to the load. This is unlike the more common differential drivers which provide only half the voltage output when operated unbalanced to ground. The COMPELLOR output stage provides full output swing to an unbalanced load by grounding the unused pin (usually Pin 2 of the output connector to maintain phase integrity).

Normally, this method would short out the negative polarity output driver, but the COMPELLOR output stage incorporates a cross-coupled bridge type circuit which senses lack of drive at either output pin, and shifts gain to the alternate output driver while removing gain from the shorted driver. This maintains normal system gain and output to any type of load, be it a balanced line or unbalanced line. This technique also eliminates heavy ground currents that normally occur due to shorting the output driver to ground. The result of this unique circuit is that it simulates the desirable characteristic of a transformer coupled output stage while eliminating the undesirable distortions and bandwidth limitations of transformers.

Output level normalizing is accomplished by the user through changing a gain determining jumper. This sets the OVU output level at +8, +4, 0 or -10 dBv as desired. U106A&B form a single-ended to balanced buffer/driver stage having programmable gain. This stage receives audio directly from the VCatt circuit through the level pot for each channel, RV302 or 402. U107A&B form a cross-balanced bridge amplifier, differentially driven, with a differential output and essentially unity gain. Output drive capability is boosted by current

boost transistors Q104, 105, 106 and 107. Careful attention to the feedback stability has produced an exceptionally transparent output circuit. All capacitors in the output circuit are somewhat critical, and should be replaced with equal types if the user ever finds it necessary to service the unit in the field.

A point of interest that should be noted is that the COMPELLOR audio path from input to output is completely differential, except at the VCAtt output node. At this point it is converted to a single-ended path to provide convenient sidechain drive and output level adjustment. The significance of this is that the differential audio path is less susceptible to noise, has less distortion and greater slew rate than a totally unbalanced audio path would exhibit. This, together with the fact that the 1537A VCAtt is an extraordinarily transparent gain control element, gives the COMPELLOR an extremely clean audio path which is subjectively unnoticeable in even the most sophisticated, high caliber audio recording or reproducing systems.

8.4 THE PEAK LIMITER

The COMPELLOR Peak Limiter circuit is driven directly by the VCA output node. R136 and R137 set the peak amplitude threshold at which limiting takes place. U102B is a unity gain buffer which drives the pulse generator pair, Q101, and Q102. Q101 is operated common-base, and when the emitter is driven positive by the V_{be} of the transistor, about 0.65 volts, then Q101 pulls collector current through R138. This produces a pulse on the base of Q103, the pulse amplifier/current pump. Q102 is operated common emitter, so when U102B drives its base negative by the V_{be} of the transistor, which is the same as for Q101, about 0.65 volts; collector current is pulled also through R138. This produces a pulse on the base of Q103.

Q103 is operated as a common emitter switch tied to the negative supply rail. When it is turned on by a pulse either generated by Q101 or Q102, it passes charging current through R140 to storage capacitor C115. R140 serves to limit the maximum charge rate, and thus peak current, through Q103 to a safe value, while maintaining sufficiently fast attack to provide near instantaneous limiting required for catching high frequency audio peaks and transients.

R142 allows C115 to discharge between charge pulses, and its value sets the release time of the limiter.

U108B is a voltage follower/buffer to transfer the control voltage developed across C115 to the VCA control port.

U108A serves as a threshold detector and monostable trigger to flash the "LIMIT" LED whenever there is significant peak limiting happening. When the control voltage exceeds the reference voltage at the junction of R147 and R148, U108A switches state to an output high, which swings approximately to the positive supply rail. D101 couples this positive pulse to the front panel "LIMIT" LED. For a period while C114 is charging to a stable condition, U108 remains high due to the positive feedback of C114. When C114 reaches a full charge, U108 reverts back to a output low, and the LED extinguishes. The one-shot type LED drive is necessary since most peak limiting is of too short

duration to permit visible display.

8.5 LEVELING SIDECHAIN

The leveling technique in the COMPELLOR uses an unusual concept in both level detection, and in control voltage generation. U201 with associated components, forms a full-wave rectifier and is driven from the "Process Balance" pot. Drive is therefore increased or decreased depending on the option of the user as to how he programs the leveling/compression balance.

A positive-sense absolute value representation of the audio signal is placed at the positive port of comparator U202A from the rectifier U201A. A reference voltage of approximately 0.65 volts is placed on the negative port of the comparator by current limiter R213, and diode-connected transistor, Q203.

U202A produces a pulse train which transitions whenever the absolute value signal passes through the reference threshold of 0.65 volts. Thus, the pulse train duty cycle and pulse rate contains complex information about the power level of the audio wave. Since the output of U202A swings to both supply rails, the negative swing is blocked, and the positive pulse polarity is passed by D208, as needed by the remaining circuitry.

R214 and R216 form an attenuator which provides the desired pulse amplitude at the source of FET Q202. Q202 is operated as a switch, passing or blocking the pulses to R222, and pin 1 of the channel interconnect DIP socket.

R222, along with C205 form a slow integrator which converts the comparator pulse train to a DC voltage. U204 buffers the integrator, and feeds the derived control voltage to the VCA control port summing stage, U105B.

Q202 is part of a gating system which freezes the control voltages as commanded either by the DVG and Silence Gate busses by using diodes D204, D205, and isolation diode D203. When either gate bus goes negative, the gate of Q202 is forced negative, thus opening the source-drain channel, and isolating R222. Since R222 both charges and discharges C205, the voltage which has been developed on C205 will "hold" until Q202 once again "closes". The leveling integrator will then begin to follow the power level contained in the pulse train from U202A.

8.6 COMPRESSION SIDECHAIN

Several features in the compressor are proprietary, and are included in the DRC Module shown in the schematic. Basically, however, the compressor sidechain receives drive from the "Process Balance" pot, and therefore, the drive will vary depending on the user's settings. The DRC module contains the heart of the level detector, and circuits that control the attack and release characteristics which are part of the uniqueness of the COMPELLOR.

Q201 is a switch that is part of the gating structure in the

COMPELLOR. C203 is a portion of the control voltage generating circuit where it acts as an integrating element, and follow-and-hold element. When Q201 is "on", C203 is connected in the circuit, and follows the compression level detector output from the DRC module. Buffer U204A passes the control voltage to the VCA control port summer U105B.

The gate of Q201 is connected to the DRC and Silence Gate busses by isolation diode D201, and oring diodes D204 and D205. If either bus goes negative, Q201 turns "off", isolating C203, and causing the control voltage that had been developed across it to "hold". This effectively freezes the gain instruction from the compression sidechain to the VCA. When Q201 again turns "on", the compression sidechain instantly normalizes to its new operating conditions.

U201B, and associated components, support the DRC and compression level detecting system.

8.7 THE DYNAMIC VERIFICATION GATE

Abbreviated "DVG", this circuit provides drive signals to the follow-and-hold portions of the leveling and compression sidechains. A sample of processed audio is taken from the output of the VCA, and converted to a differential signal at the DVG module, pins 3 and 4. The module contains proprietary circuits that drive comparator U202B. Pulses thus produced are passed to the gating bus by D205. D209 couples the pulses to the DVG LED on the front panel.

8.8 SILENCE GATE CIRCUIT

Refer to the Channel "B" board schematic diagram. A sample of audio is taken from each channel's input amplifier through R446 and R447. The left and right audio is summed across the Threshold control, RV404. RV404 is a reverse taper potentiometer, so that greater audio drive is obtained in the counter-clockwise direction of adjustment. This audio is sent to U409, and associated components, which form a half-wave gain stage. The gain is about 60dB in this stage in order to obtain sufficient sensitivity to detect levels to 40dB below operating level of the input stages of the two channels.

Half-wave rectified audio pulses are fed through D415 into a storage filter consisting of C421, R443 and the two LEDs, LD417 and LD418. Resistor R442 sets the attack time of the threshold detector by limiting charging current to C421. This time constant is made short to permit fast recognition of audio presence by the detector.

LD419 and R444 provide a voltage reference of one LED drop, about 1.7 volts to the comparator, U409A. LD417 and LD418 form a voltage limiter to keep the storage capacitor from acquiring an excessive charge. When audio falls below the point that produces a voltage on C421 of one LED drop, the comparator U409 goes low, or negative, at the output. This condition represents silence detection, and the negative comparator signal is passed to the gating bus in the process sidechains.

Diodes LD417 and LD418 cause the charge on the filter capacitor C421 to limit, thus allowing repeatable, consistent timing of silence

detection, regardless of the character or level of the audio program.

8.9 STEREO ENHANCE

Refer to the Channel "B" board schematic. Amplifiers U408A&B are the A and B channel sidechain drivers, respectively. For discussion, consider the channel A driver, U408A. Channel A VCatt output is fed to U408A through input resistor, R432. The gain of this stage sets the operating threshold of the sidechains relative to the program level at the VCatt output.

The driver output is split to two paths, one to the leveler and one to the compression sidechain. R425, R426, and RV403 form a bridge which adjusts the relative drive to the two sidechains.

In the stereo enhance mode, a small portion of the alternate channel's audio is added out of phase to the audio at each driver stage. The Stereo Enhance switch injects or interrupts the alternate channel audio feeds.

9.0 COMPELLOR FINAL TEST PROCEDURES

The following tests are not comprehensive. They verify the essential operating characteristics for performance assurance at or near final burn-in time prior to delivery to the customer, and for a quick field test of operation.

Refer to figures 1 and 2 for the standard test equipment hook-up, and special test fixture diagram for peak limiter testing.

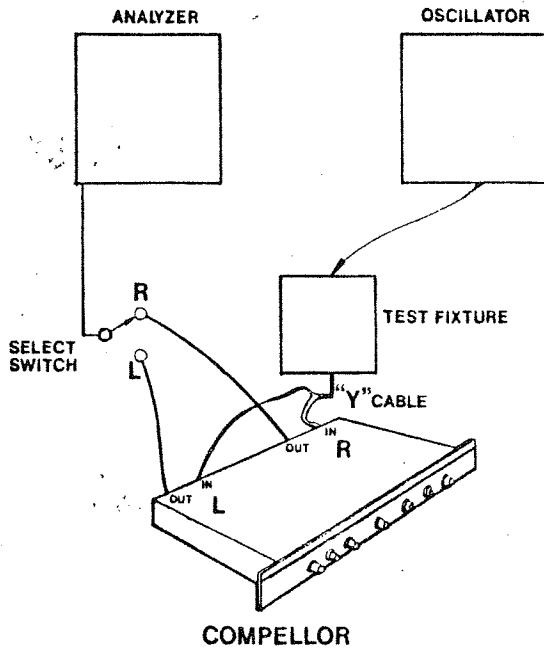

Figure 1. Standard Test Equipment Hook-Up

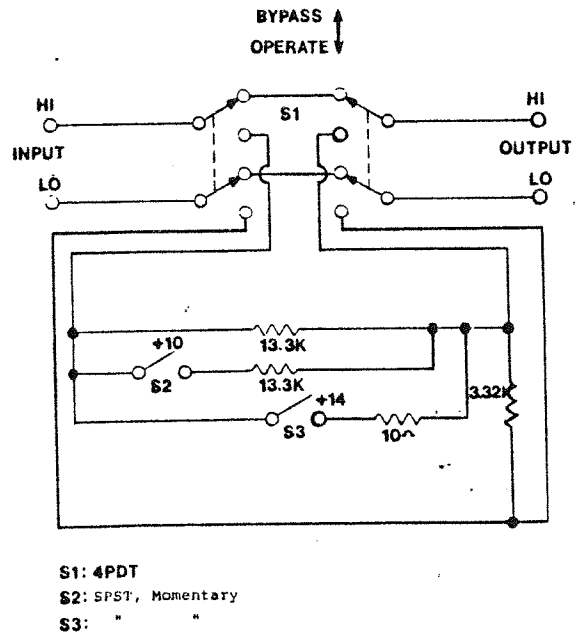

Figure 2. Compellor Final Test Special Fixture

9.1 COMPELLOR COMPRESSION TEST

Initial Set-Up:

1. Silence Gate full CCW
2. Stereo Enhance OFF
3. All other knobs full CW
4. COMPELLOR IN
5. Oscillator frequency = 400HZ
6. Metering to PROCESS
7. I/O normalized to +4

Test Procedure:

<u>Step</u>	<u>Operation</u>	<u>Indications</u>
1.	Oscillator output = +6dBv	A. Full scale green LED's B. Output level = +17.4 + 1dB C. Channels match within 1dB
2.	Drop oscillator 10dB to -4	A. 6 green LED's lit B. Output level = +14dBv +1dB C. Channels match within 1dB
3.	Drop oscillator 10dB to -14	A. 3 green LED's lit B. Output level = +9dBv + 1dB C. Channels match within 1dB
4.	Stereo Enhance to On	A. Output level increase .4dB B. Channels increase same amount within 1/4dB

9.2 COMPELLOR LEVELING TEST

Initial Set-Up:

Everything the same as for compression test except:

1. Left input knob at 3 o'clock
2. Right input knob full CCW
3. Process balance full CCW

Test Procedure:

<u>Step</u>	<u>Operation</u>	<u>Indications</u>
1.	Oscillator level = -7dBv	A. Approx 2 LED's lit B. Lt output = +13dBv within 1dB C. Rt output = 0
2.	Raise Rt input knob until Lt output drops 0.1 to 0.2dB	A. Rt out + Lt out at +13dBv B. Channels match within 1dB
3.	Increase oscillator to 0dBv	Rt & Lt outputs settle to +13dBv and match within 1dB
4.	Increase oscillator to +10dBv	Rt & Lt outputs settle to +13dBv and match within 1dB
5.	Suddenly drop the oscillator level by 20dB	Rt & Lt output levels recover to +9dBv and track within 1dB Worst divergence should never exceed the measured static level difference at any level (+1/2dB).
6.	Additional tracking test: Set output levels exactly equal, repeat steps 4 & 5	Difference during recovery should be negligible (+1/2dB).

9.3 COMPELLOR PEAK LIMIT TEST

Initial Set-Up:

1. Stereo Enhance OUT
2. Process Balance full CCW (leveling mode)
3. Input and output knobs at full CCW
4. Other controls don't matter
5. Feed inputs through special test fixture per fig 2
6. Oscillator at 400HZ
7. I/O normalized at +4
8. I/O switch "OUT"

Test Procedure:

<u>Step</u>	<u>Operation</u>	<u>Indications</u>
1.	Oscillator output at +10dBv. Turn Rt input knob full CCW	
2.	Press the "+10" button on the test fixture	The LED's will indicate gain reduction, but the peak light will not flash
3.	Release the "+10" button and let gain reduction recover. When gain is recovered, press the "+14" button on the fixture	The LED's will indicate gain reduction and the peak light will flash once or twice briefly.
4.	Turn the Lt input knob full CCW, and turn up the Rt input knob to 12 o'clock	
5.	Repeat steps 2 & 3 for the right channel	

9.4 ADDENDUM

Sample Test Data

Test Step (Compression):

	Left	Right
1.	+13.75	+13.5
2.	+10.8	+10.6
3.	+ 6	+ 5.75

Test Step (Leveling):

1.	+ 8.7	+ 8.3
2.	+ 8.8	+ 8.6
3.	+ 9.05	+ 9.3

10.0 DISSASSEMBLY GUIDE and MECHANICAL PARTS LIST

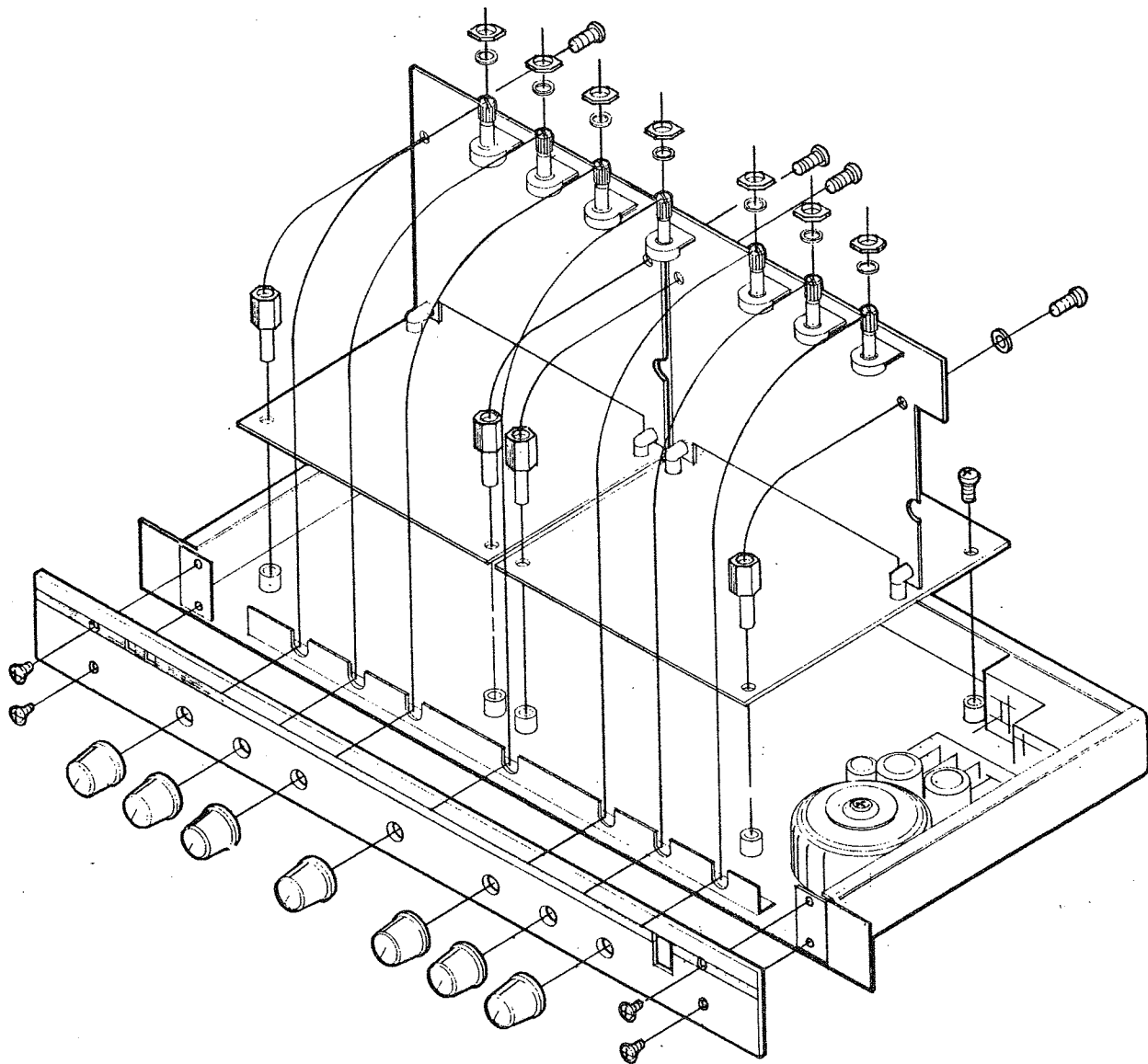

I. DISSASSEMBLY

- 1) () REMOVE TOP COVER, DON'T LOSE THE SCREWS.
- 2) () REMOVE KNOBS. SOME EARLY MODELS HAVE COLLET TYPES, LATER ONE ARE SIMPLE PUSH-ONS.
- 3) () REMOVE FACEPLATE.
- 4) () UNPLUG THE (3) POWER CABLE FROM THE PROCESSING BOARDS (RED MOLEX CONNECTORS)
- 5) () UNPLUG THE SHORT DIP JUMPER BETWEEN THE TOP BOARDS.
- 6) () LOOSEN POTENTIOMETER MOUNTING NUTS (7)
- 7) () REMOVE THE (4) PHILLIPS SCREWS SECURING THE FRONT OF THE DISPLAY BOARDS, THEY MAY NOW BE TILTED UPRIGHT.
- 8) () REMOVE THE (2) 1/4" STANDOFFS AT THE FRONT OF EACH I/O BOARD.
- 9) () REMOVE THE (2) PHILLIPS SCREWS AT THE REAR OF EACH I/O BOARD.
- 10) () EACH ASSEMBLY MAY NOW BE LIFTED FROM THE CHASSIS.

- BLOCK DIAGRAM -

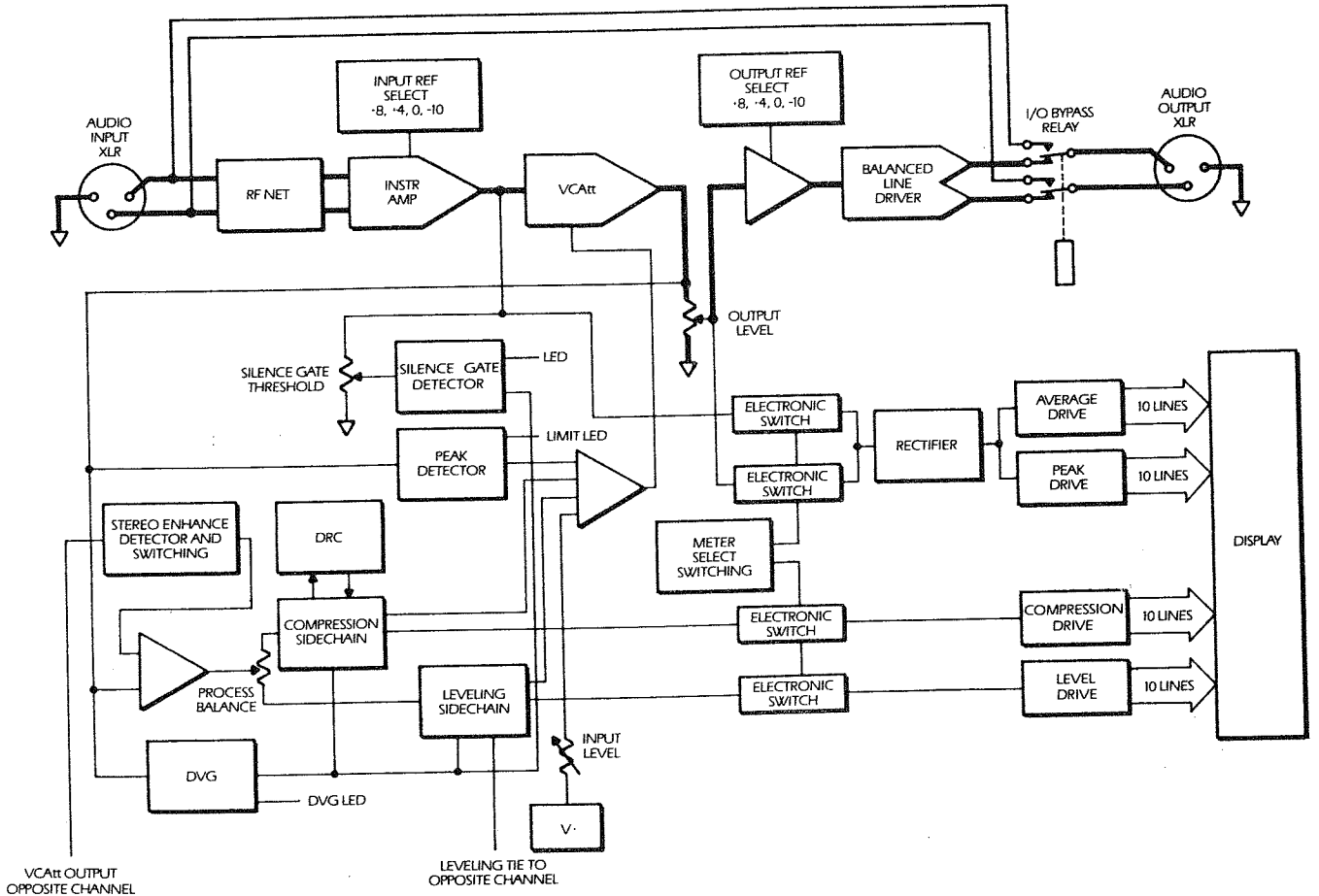

12.0 SCHEMATIC DIAGRAMS AND PARTS LISTS

- 12.1 I/O and PROCESSING CIRCUITS
- 12.2 CONTROL and DISPLAY CIRCUITS
- 12.3 POWER SUPPLY

PARTS LIST

RESISTORS

Rv101 - 10K 10 turn	R117 - 3K32 1%	R134 - 825R 1%	R151 - 10K0	R168 - 10R
R101 - 100K 1%	R118 - 3K32 1%	R135 - 1K0 1%	R152 - 1K0 1%	R169 - 10R
R102 - 100K 1%	R119 - 330K	R136 - 34K0	R153 - 20K0 1%	R170 - 10R
R103 - 20K0 1%	R120 - 270K	R137 - 10K0	R154 - 16K2 1%	R171 - 10K0
R104 - 20K0 1%	R121 - 3K32 1%	R138 - 2K7	R155 - 9K31 1%	R172 - 10R
R105 - 13K3 1%	R122 - 3K32 1%	R139 - 2K7	R156 - 4K99 1%	R173 - 10K0 1%
R106 - 13K3 1%	R123 - 46K4 1%	R140 - 4K7	R157 - 2K87 1%	R174 - 10K0 1%
R107 - 10K0 1%	R124 - 20K0 1%	R141 - 1K0	R158 - 10K0 1%	R175 - 10K0 1%
R108 - 10K0 1%	R125 - 13K2 1%	R142 - 1M0	R159 - 10K0 1%	R176 - 10K0 1%
R109 - 2K87 1%	R126 - 13K2 1%	R143 - 150R	R160 - 560R 1%	R177 - 100K 1%
R110 - 13K3 1%	R127 - 4K99 1%	R144 - 1K0	R161 - 10K0 1%	R178 - 2K7
R111 - 34K2 1%	R128 - 4K99 1%	R145 - 1K0	R162 - 10K0 1%	R179 - 2K7
R112 - not used	R129 - 10K0 1%	R146 - 1M0	R163 - 10K0 1%	R180 - 10R
R113 - 10K0 1%	R130 - 21R5 1%	R147 - 10K0	R164 - 10K0 1%	R181 - 10R
R114 - not used	R131 - 10K0 1%	R148 - 150R	R165 - 100K 1%	R182 - 10R
R115 - 10K0 1%	R132 - 150R	R149 - 47K0	R166 - 2K7	R183 - 10K0
R116 - 150R	R133 - 20K0 1%	R150 - 10K0	R167 - 2K7	R184 - 10R

R202 - 10K0	R208 - 1K0	R214 - 10K0	R220 - 2K0	R226 - 10K0
R203 - 10K0	R209 - 10K0	R215 - 1M0	R221 - 1K2	R227 - 10K0
R204 - 15K0	R210 - 10K0	R216 - 10K0	R222 - 5M6	R228 - 1K0
R205 - 56R	R211 - 10K0	R217 - 2K0	R223 - 1K0	R229 - 1K0
R206 - 1M0	R212 - 1K0	R218 - 2K0	R224 - 10K0	
R207 - 33K0	R213 - 10K0	R219 - 750R	R225 - 22K0	

Resistors $\frac{1}{4}$ W, 5%, except as specified.

R = Ohm; K = K-Ohm; M = M-Ohm

CAPACITORS

C101 - 150pf	C110 - 20pf	C119 - 100uf/25V	C128 - 22uf/25V	C137 - 100uf/25V
C102 - 150pf	C111 - 10pf	C120 - 10pf	C129 - 22uf/25V	C138 - 0.1uf
C103 - 22uf/25V	C112 - 10pf	C121 - 10pf	C130 - 100uf/25V	C139 - 0.1uf
C104 - 22uf/25V	C113 - 0.001uf	C122 - 20pf	C131 - 100uf/25V	C140 - 0.1uf
C105 - 20pf	C114 - 0.01uf	C123 - 20pf	C132 - 100uf/25V	C141 - 0.1uf
C106 - 20pf	C115 - 0.01uf	C124 - 20pf	C133 - 100uf/25V	C142 - 0.1uf
C107 - 20pf	C116 - 20pf	C125 - 20pf	C134 - 330uf/25V	C143 - 0.1uf
C108 - 20pf	C117 - 20pf	C126 - 22uf/25V	C135 - 330uf/25V	C144 - 0.1uf
C109 - 100uf/25V	C118 - 100uf/25V	C127 - 22uf/25V	C136 - 100uf/25V	C145 - 0.1uf

C201 - 1uf/tant	C205 - 1uf/tant	C209 - 1uf/tant	C213 - 0.1uf	C217 - 100uf/25V
C202 - 47pf	C206 - 4.7uf/25V	C210 - 0.15uf	C214 - 0.1uf	C218 - 100uf/25V
C203 - 1uf/tant	C207 - 10pf	C211 - 0.1uf	C215 - 0.1uf	
C204 - 47pf	C208 - 47pf	C212 - 0.1uf	C216 - 0.1uf	

tant = tantalum capacitor

TRANSISTORS

Q101 - 2N3906	Q103 - 2N3904	Q105 - MJE171	Q107 - MJE171
Q102 - 2N3906	Q104 - MJE181	Q106 - MJE181	

Q201 - J113	Q202 - J113	Q203 - 2N3906	

ICs, DIODES, CHOKE

ICs:	U101, U102, U103, U106, U107, U201, U202, U203, U204 = LF353;	U104 = 1537A	U105 = NE5532N
DIODES:	D101, D102, D103, D104, D105, D106, D107, D108, D109, D111, D112, D113 = 1N914B	D110 = 1N4003	
CHOKE:	Special, Aphex Part # 72-003	D201, D203, D204, D205, D206, D207, D208, D209 = 1N914B	

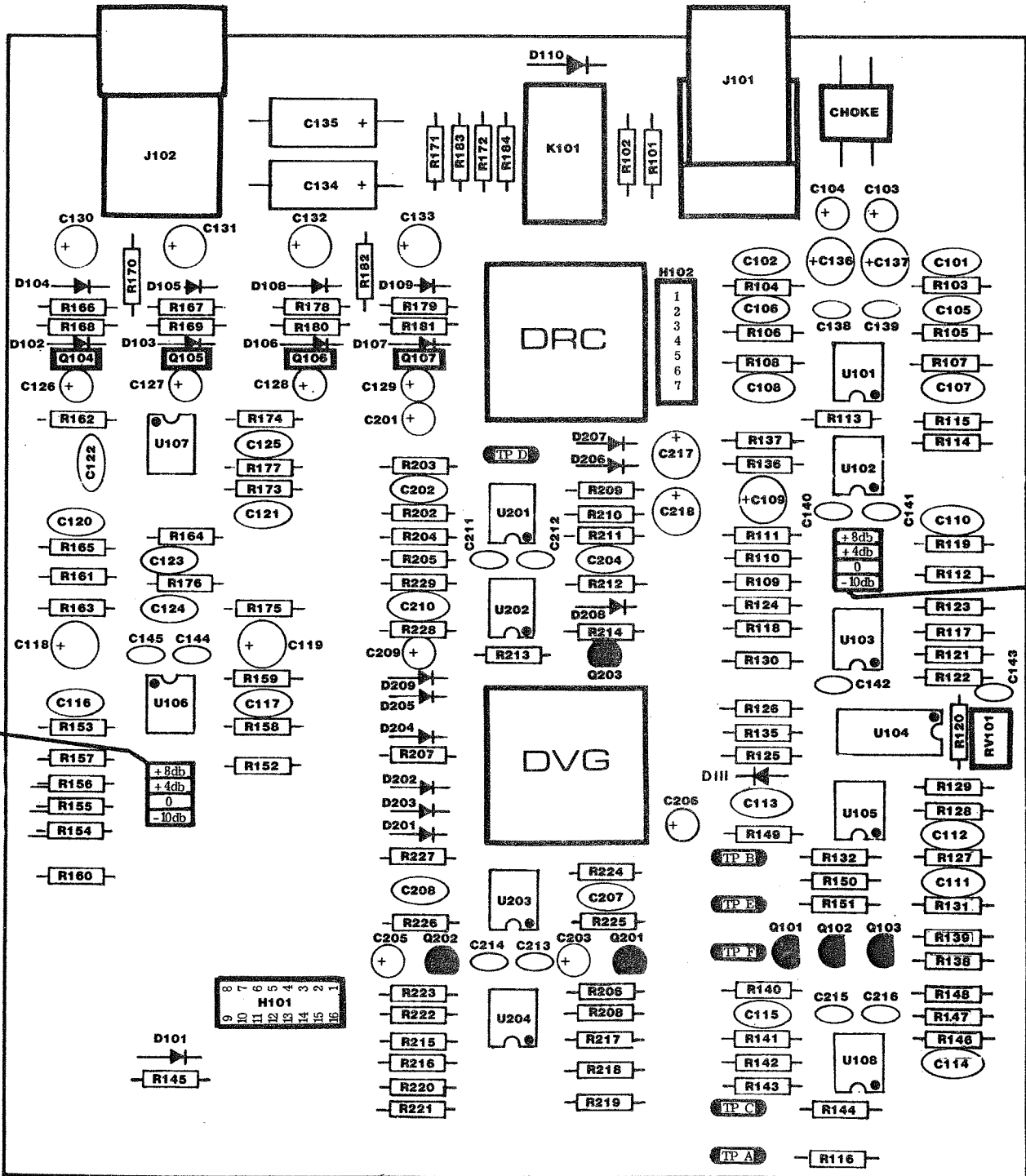

* THESE JUMPERS ARE USED TO MATCH THE COMPELLORS INPUT, METERING AND OUTPUT CIRCUITS TO ANY SYSTEM.

**INSTALLATION OF
PARTS ON BOTTOM
OF I/O BOARD**

R134

D112

R133

D113

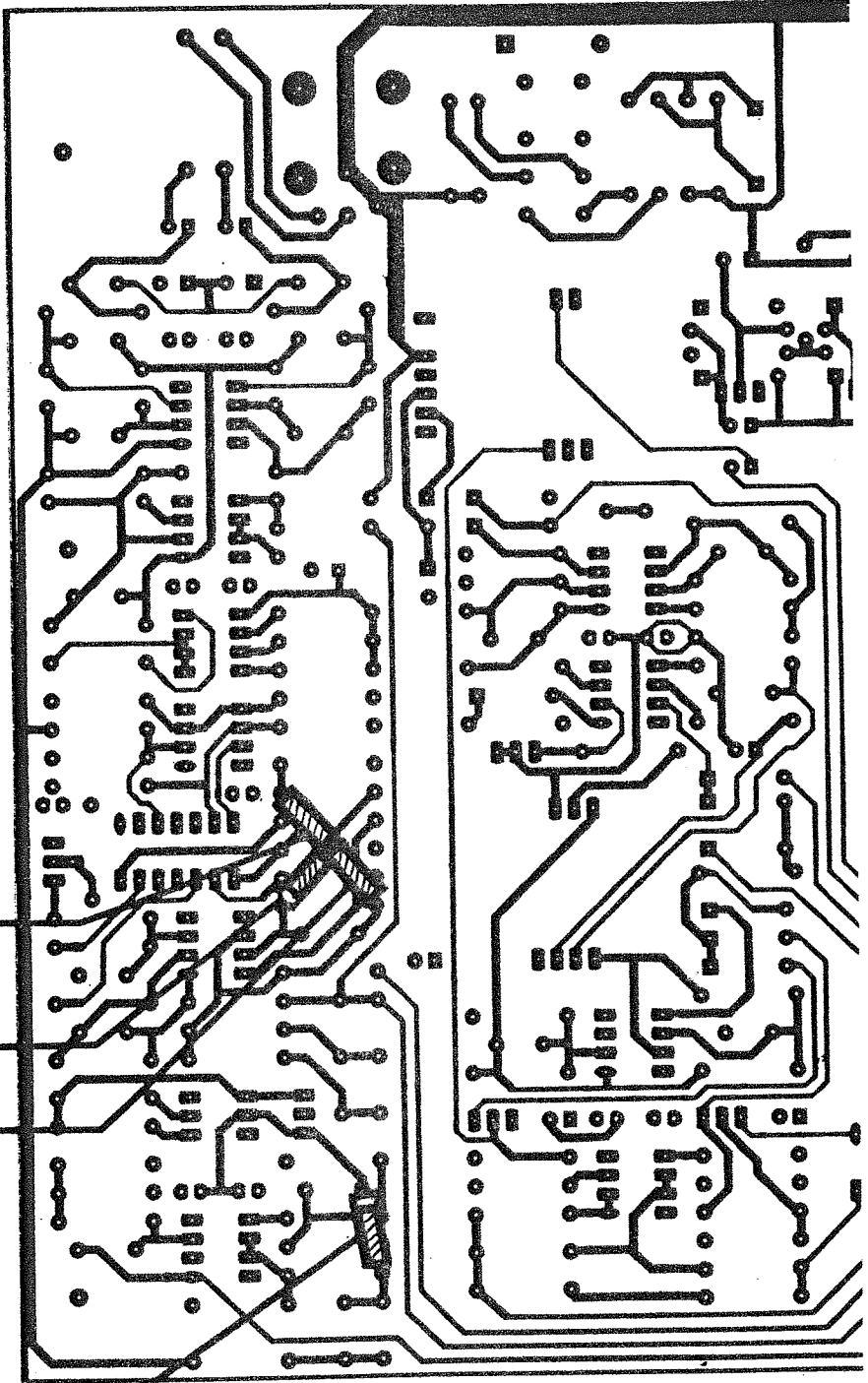

AUDIO BOARD
ORIENTATION:
SOLDER SIDE
SOLDER VIEW

PARTS LIST

RESISTORS

Rv301 - 10K Rv401 - linear	Rv302 - 10K Rv402 - audio	Rv303 - 3K Rv403 - linear	Rv404 - 10K rev. audio	
R301 - 1K0	R308 - 100K	R315 - 3K6	R322 - 10K0	R329 - 10K0
R302 - 20K0	R309 - 100K	R316 - 10K0	R323 - 20K0	R330 - 100K
R303 - 1K0	R310 - 1K0	R317 - 100K	R324 - 820R	R331 - 100K
R304 - 5K6	R311 - 3K6	R318 - 1K0	R325 - 5K6	R332 - 20K0
R305 - 33K0	R312 - 10K0	R319 - 10K0	R326 - 5K6	
R306 - 10K0	R313 - 100K	R320 - 820R	R327 - 1K0	
R307 - 10K0	R314 - 1K0	R321 - 4K7	R328 - 1K0	

R401 - 1K0	R411 - 3K6	R421 - 4K7	R431 - 3K6	R441 - 100K
R402 - 20K0	R412 - 10K0	R422 - 10K0	R432 - 8K25	R442 - 1K0
R403 - 1K0	R413 - 100K	R423 - 20K0	R433 - 57K6	R443 - 2M2
R404 - 5K6	R414 - 1K0	R424 - 820R	R434 - 8K25	R444 - 10K0
R405 - 33K0	R415 - 3K6	R425 - 5K6	R435 - 57K6	R445 - 1K0
R406 - 10K0	R416 - 10K0	R426 - 5K6	R436 - 33K0	R446 - 2K0
R407 - 10K0	R417 - 100K	R427 - 1K0	R437 - 3K6	R447 - 2K0
R408 - 100K	R418 - 1K0	R428 - 1K0	R438 - 150R	R448 - 100R
R409 - 100K	R419 - 10K0	R429 - 10K0	R439 - 100K	R449 - 150R
R410 - 1K0	R420 - 820R	R430 - 33K0	R440 - 100R	R450 - 56R

Fixed resistor $\frac{1}{4}$ W, 5%

R = Ohm; K = K-Ohm; M = M-Ohm

CAPACITORS

C301 - 20pf	C304 - 20pf	C307 - 100uf/25V	C310 - 100uf/25V	C313 - 0.1uf
C302 - 1uf/tant	C305 - 20pf	C308 - 100uf/25V	C311 - 0.1uf	C314 - 0.1uf
C303 - 1uf/tant	C306 - 22uf/25V	C309 - 100uf/25V	C312 - 0.1uf	

C401 - 20pf	C406 - 22uf/25V	C411 - 0.1uf	C416 - 10pf	C421 - 1uf/tant
C402 - 1uf/tant	C407 - 100uf/25V	C412 - 0.1uf	C417 - 100uf/25V	
C403 - 1uf/tant	C408 - 100uf/25V	C413 - 0.1uf	C418 - 10pf	
C404 - 20pf	C409 - 100uf/25V	C414 - 0.1uf	C419 - 100uf/25V	
C405 - 20pf	C410 - 100uf/25V	C415 - 0.1uf	C420 - 4.7uf/25V	

tant = tantalum capacitor

TRANSISTORS

Q301 - 2N3906	Q304 - 2N3906	Q307 - 2N3906	Q310 - 2N3906	Q313 - 2N3904
Q302 - 2N3906	Q305 - 2N3906	Q308 - 2N3906	Q311 - J113	Q314 - 2N3904
Q303 - 2N3906	Q306 - 2N3906	Q209 - 2N3906	Q312 - J113	

Q401 - 2N3906	Q404 - 2N3906	Q407 - 2N3906	Q410 - 2N3906	Q413 - 2N3904
Q402 - 2N3906	Q405 - 2N3906	Q408 - 2N3906	Q411 - J113	Q414 - 2N3904
Q403 - 2N3906	Q406 - 2N3906	Q409 - 2N3906	Q412 - J113	

ICs, DIODES, LEDs

ICs:	U301, U302, U303 U401, U402, U403, U408, U409 = <u>LF353</u>	U304, U305 U404, U405 = <u>3914</u>	U306, U307 U406, U407 = <u>3915</u>
DIODES:	D301 through 310 D401 through 410 = <u>1N6551 A or B</u>	D311, D312 D411, D412, D413, D414, D415 = <u>1N914B</u>	
LEDs:	LD301 th LD310 T-1 3/4 LD401 th LD410 = Bicolor LD413 Red/Gr	LD311 = T-1 3/4 LD411 = Red	LD312 LD412 = T-1 3/4 LD415 Yellow LD414 = T-1 3/4 Green LD416 LD417 = T-1 LD418 Green

SWITCHES

ALL SWITCHES = 4PDT latching, non-shorting, Alps SUJ Series

POWER SUPPLY

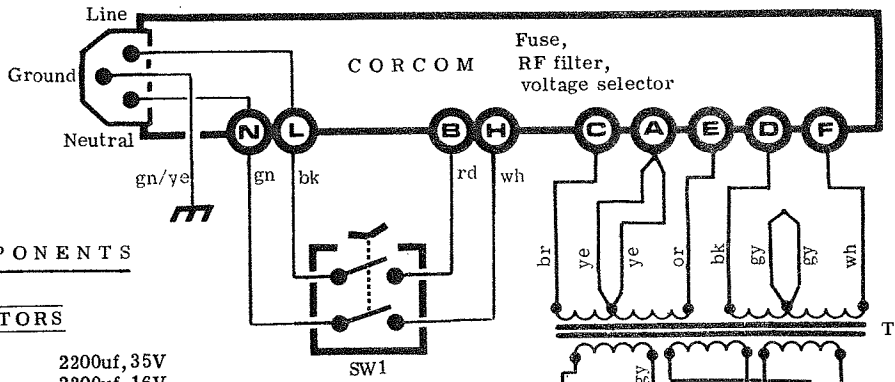

COMPONENTS

CAPACITORS

- C1, C2 2200uf, 35V
- C3 2200uf, 16V
- C4 - C8 1uf, tantalum

BRIDGES

- BR1, BR2 MDA101A
Motorola

TRANSFORMER

- T1 Toroid, Aphex pt# 70-009

REGULATORS

- REG1, REG2 LM340T-15
or 7815
- REG3, REG4 LM320T-15
or 7915
- REG5 LM340T-5
or 7805

DIODES

- ALL DIODES 1N4002

HEADERS

- H1 7 pin (AC fr T1)
- H2 7 pin (to I/O board)
- H3 7 pin (to I/O board)
- H4 6 pin (to display boards)

SWITCH

- SW1 DPDT rocker switch
Marquardt # 1852-1121

AC CONNECTOR ASSEMBLY

- UNIT = Corcom type 6J4
- FUSE = 100/120V-1A;
220/240V- $\frac{1}{2}$ A.
- RF filter & voltage selector
included in assembly.
- IEC standard input

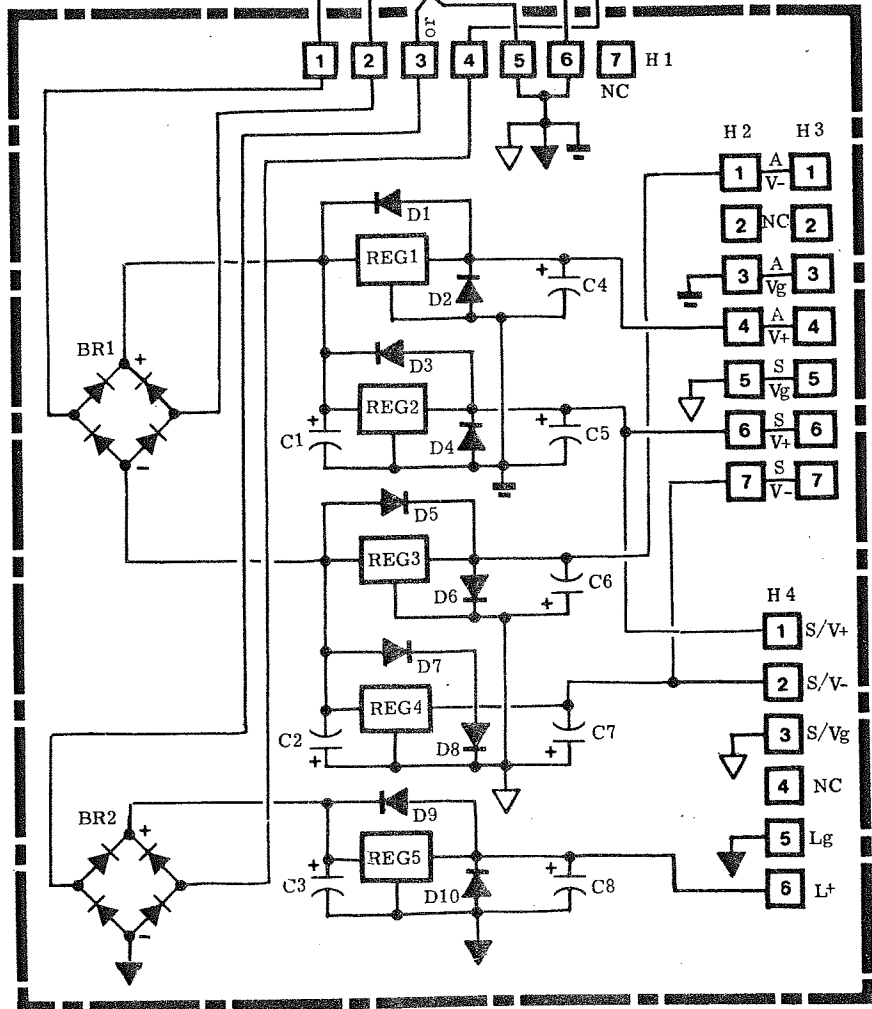

Chassis ground Audio ground Sidechain ground Logic ground

A = Audio Power; L = Logic Power; S = Sidechain Power

WIRE COLOR CODE

- gn Green
- bl Blue
- bk Black
- br Brown
- gy Gray
- or Orange
- rd Red
- wh White
- ye Yellow

APHEX COMPELLOR™

Date: October 1983

Drawn by: ITX/CK

Approved:

CIRCUIT DIAGRAM

Power Supply

REV



APHEX SYSTEMS Ltd
No. Hollywood, CA 91605

DRAWING NUMBER: **834-3**

SPECIFICATIONS

INPUT

Type • RF-filtered true instrumentation differential balanced

Input Impedance • 50K Ohms balanced

Nominal operating level • user selectable

OVU = -10, 0, +4, +8 dBm

Max Input level • +27dBm

CMRR • greater than 40 dB

SIDE CHAIN

Compression

Attack time • 5-50m Sec

Release time • 200m Sec-1 Sec } Program dependent

Ratio • 1.1:1-20:1

Threshold • 30 dB below nominal level (OVU)
with input full clockwise

Leveling

Attack time • 2.5 Sec

Release time • 5 sec } Program dependent

Rate • .5-5dB/Sec

Threshold • same as Compression

Peak Limiter

Attack time • 1 μ Sec

Release time • 10m Sec

Threshold • 12dB above nominal level (OVU)

Gain reduction element • APHEX 1537A Voltage Controlled Attenuator

OUTPUT

Type • Electronically balanced transformerless.
May be operated balanced or single-ended at full output.

Source impedance • 20 ohm balanced, 10 ohm unbalanced.

Maximum output • +27 dBm balanced or +21 dBm unbalanced.

Band width • ± 1 dB 5HZ-65kHz

Hum and noise @ unity gain, +4op level • -72dBm

Noise referred to max output • -95dBm

Dynamic THD @ 20dB compression, 1 KHZ, +4 op level • .1%

SIZE • 13/4" H x 19" W x 9" D

SHIPPING WEIGHT • 11 lbs

POWER REQUIREMENTS • 90-250 VAC, 50-60HZ, 20W

AC input is IEC standard receptacle, with fuse, voltage select & RF filter.

APPLICATION NOTE 300-2

COMPELLOR MOD FOR 2-CHANNEL
OPERATION (UNLINK)

APHEx SYSTEMS LTD.

As currently configured, the COMPELLOR is a STEREO device, in comparison to a two-channel device. The channels are linked electronically in two ways:

1. The leveling circuits are tied together to preserve stereo imaging, and
2. The Silence Gate circuit is common and will operate both channels simultaneously.

Although either channel can be used singly, the need occasionally develops for TWO SEPARATE channels, each unaffected by the other. Until the development of a dual mono unit by Aphex, the following simple modification will UNLINK the COMPELLOR's sidechains, providing two separate channels.

CAUTION: Due to the unlinking, the silence gate will function on channel B only. This must now be taken into account when selecting the material for each channel.

UNLINKING

- A. Remove cover
- B. Remove knobs
- C. Remove faceplate

See fig 1

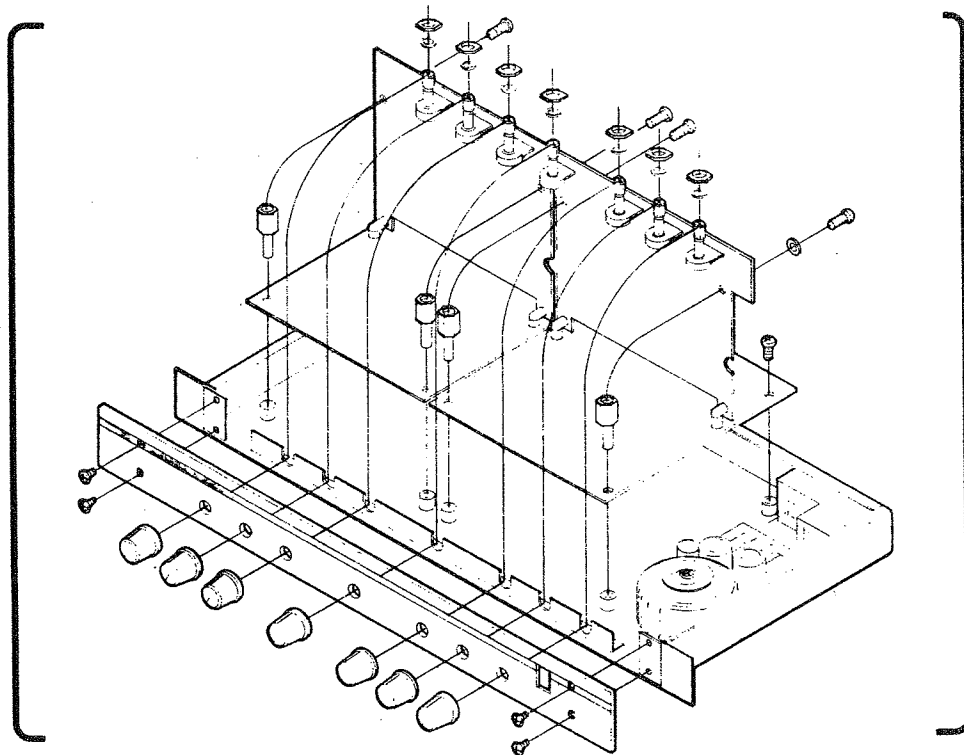

APHEx SYSTEMS LTD

- II
- A. Remove the 16 pin DIP jumper that connects the upper boards of channel A & B.
 - B. Using a razor blade or X-Acto knife, carefully separate and cut conductors 9, 10, and 16 (See Fig. 2)
 - C. Re-insert the jumper, (pin 16 towards the rear).

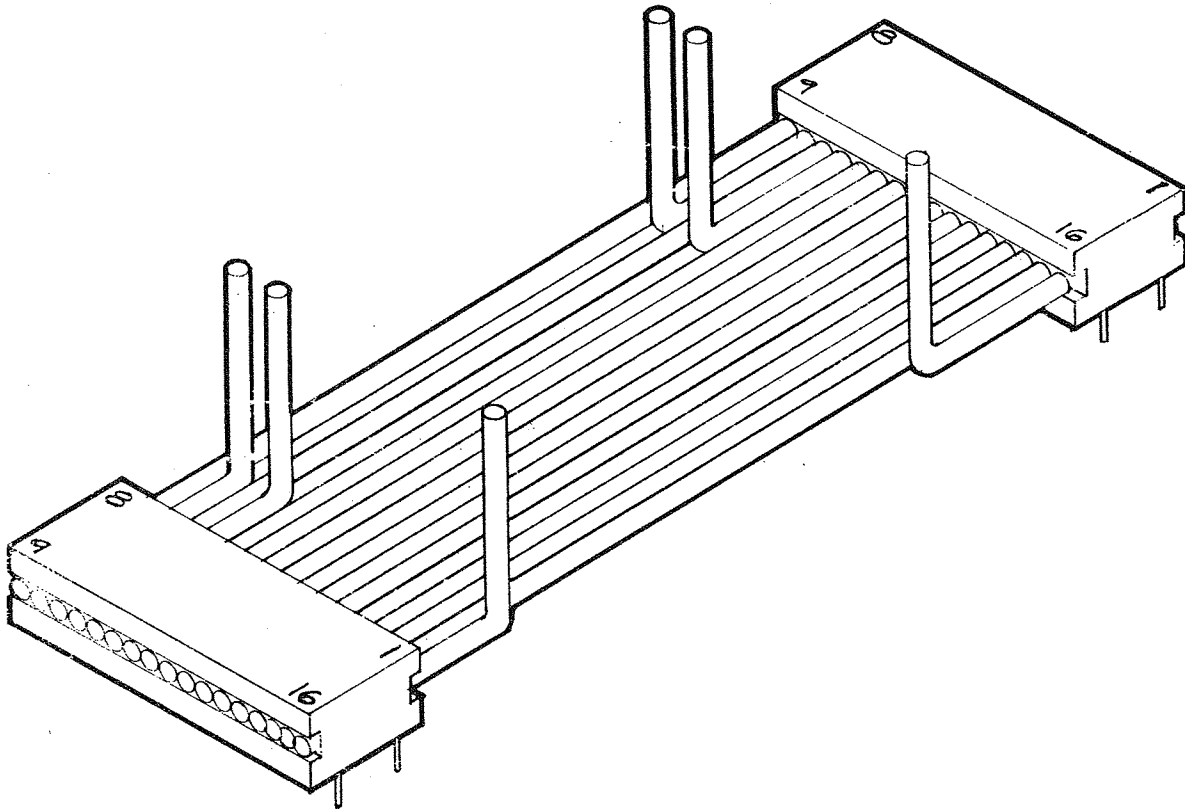

- III
- A. Loosen the pot shaft nuts on channel B board (Rt. hand side as viewed from the front).
 - B. Remove the two 8-32 Phillips screws on the front of the board.
 - C. Raise the board to an upright position. Solder a small jumper wire from the rear pad of R446 (2k) to the positive (Ground) pad of C409 (100uF, 25v) (fig 3)
- IV
- A. Lower board back into place.
 - B. Replace the two 8-32 screws.
 - C. Tighten the pot shaft nuts (carefully! Too tight will break pots!).
 - D. Check that the DIP jumper is firmly seated on both ends.
 - E. Replace faceplate.
 - F. Replace knobs.
 - G. Replace cover.
- V You now have a two-channel COMPELLOR!

I/O BOARDS (2)

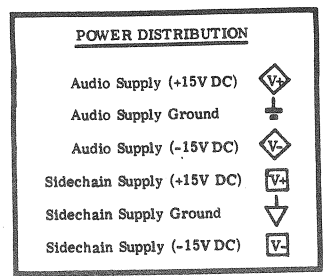
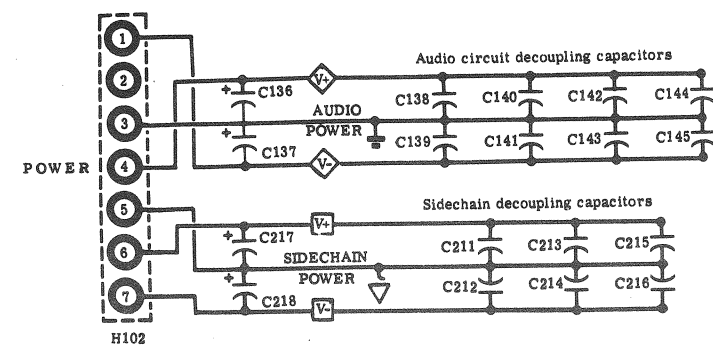
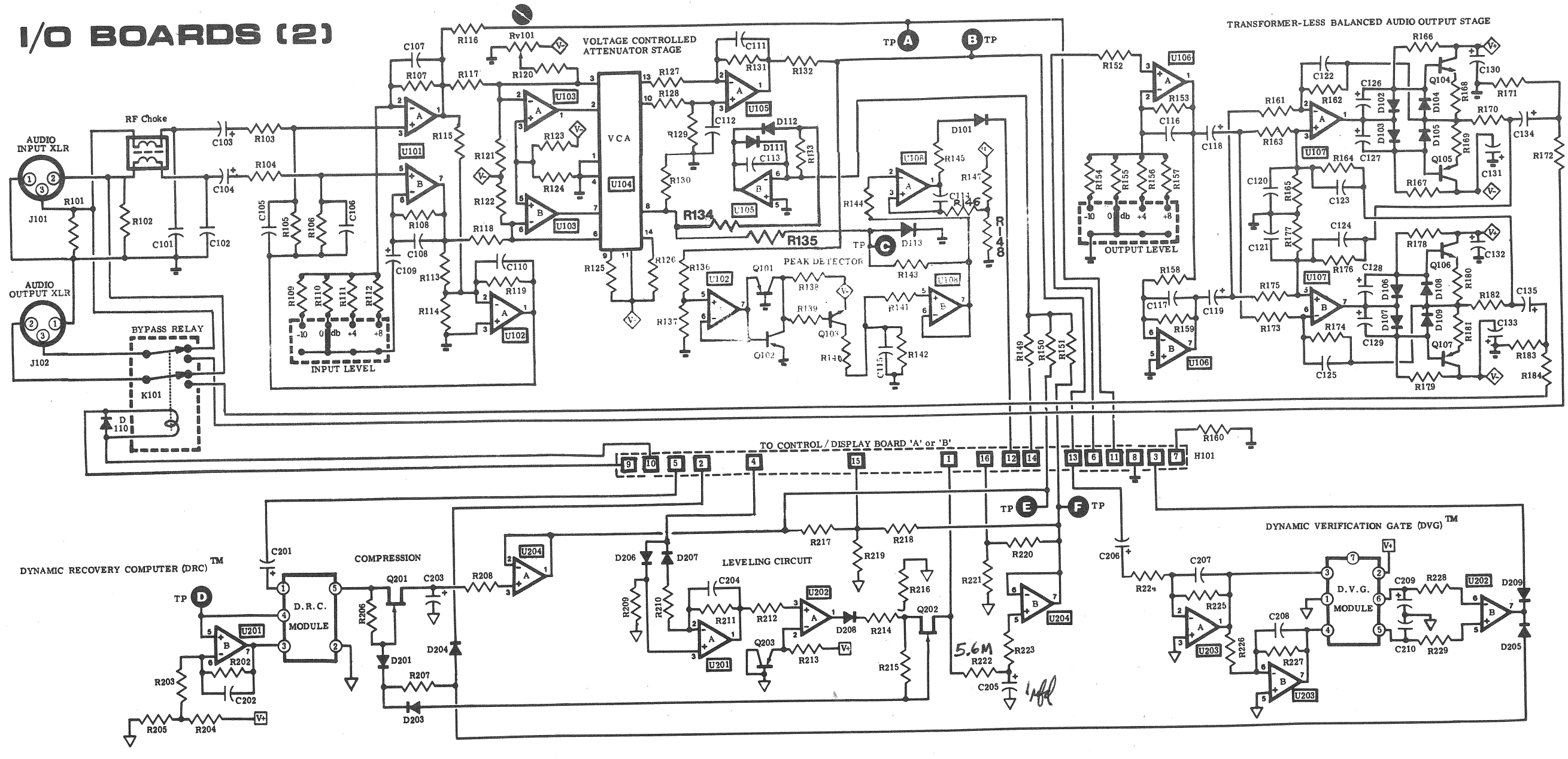

NOTES

- 1 Bipolar IC power connections are +15VDC to pin 8, -15VDC to pin 4 except as shown for U104
- 2 Observe the separate power and grounding systems for Audio and Sidechain circuits.

TEST POINTS

- (A) Buffered input
- (B) VCA out
- (C) Peak Detector out DC
- (D) D.R.C. DC
- (E) Compression DC
- (F) Leveling DC

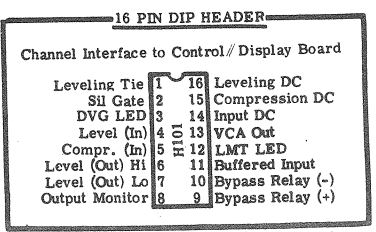

APHEX COMPELLOR™

Date: October, 1983
 Drawn by: ITX/CK
 Approved:

CIRCUIT DIAGRAMS
 AUDIO I/O and PROCESSING CIRCUITS
 One of two identical I/O PC boards.

REV. []

APHEX SYSTEMS Ltd
 No. Hollywood CA 91605

DRAWING NUMBER: **834-1**

CH-B BOARD

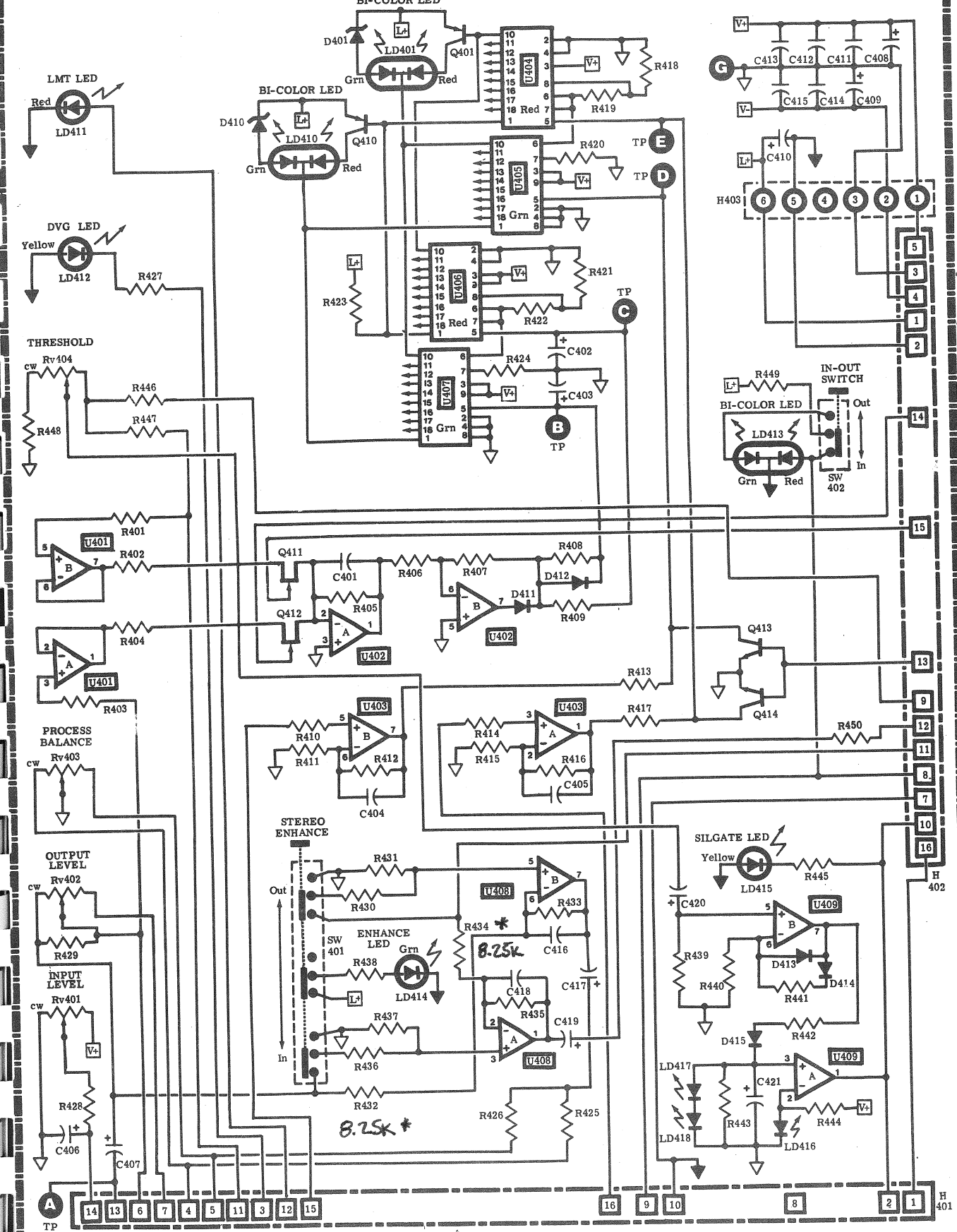

CH-A BOARD

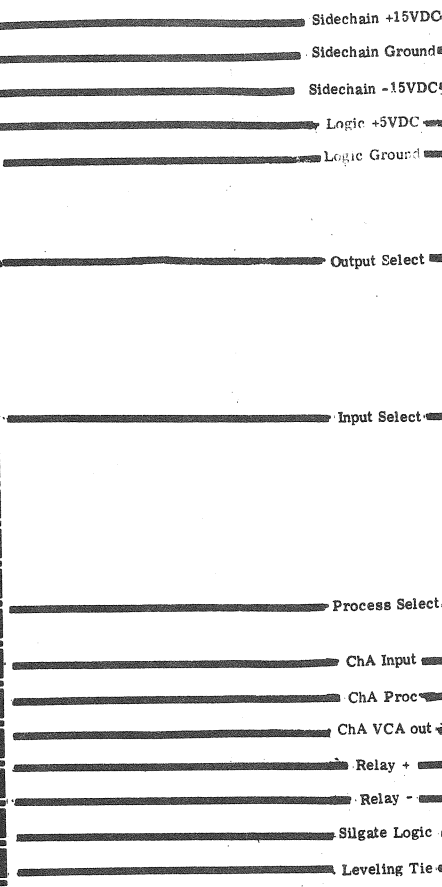
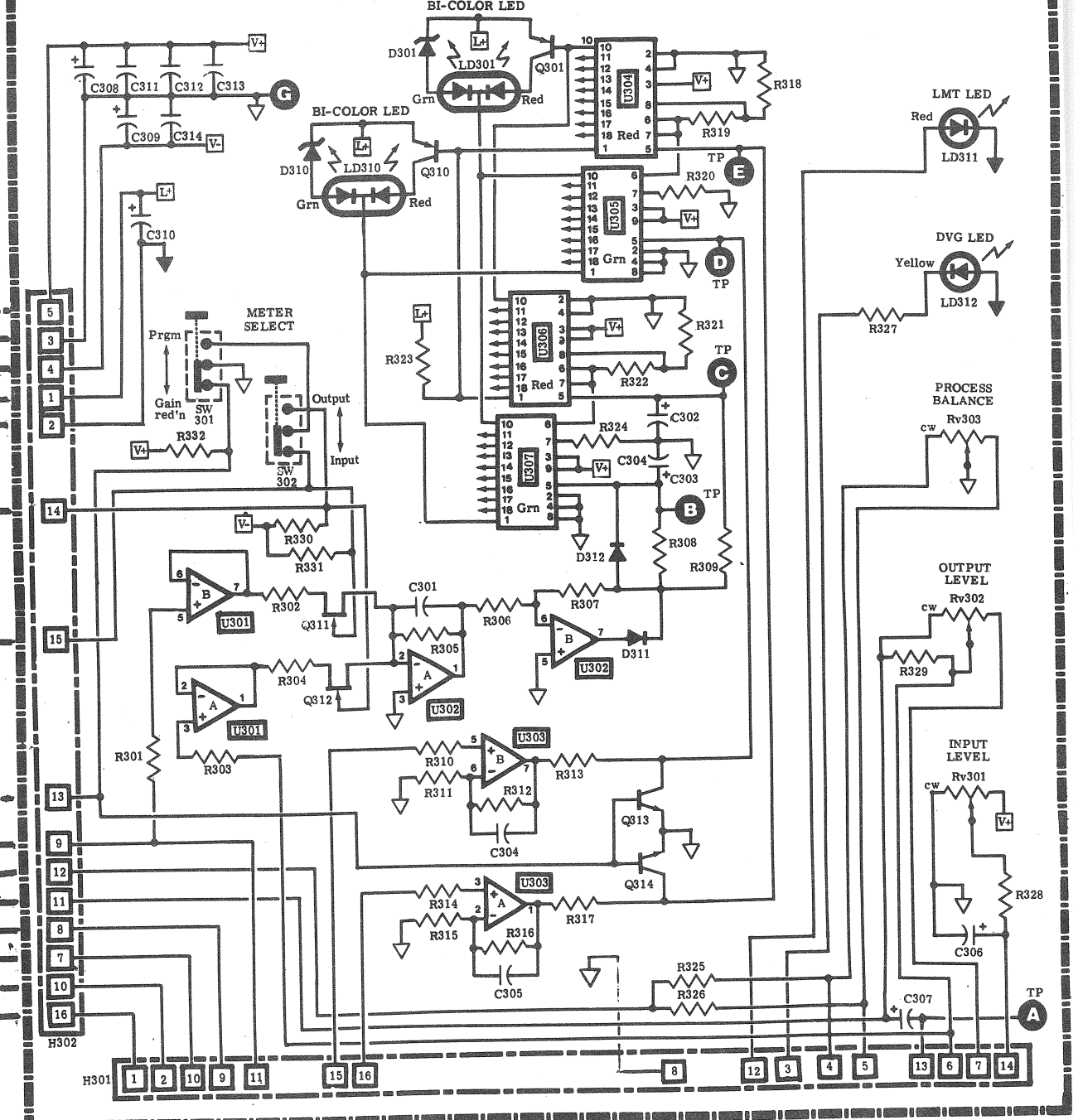

16 PIN DIP HEADERS

CH A - CH B Board Interface Headers	
Logic Supply (+)	1 16
Logic Supply (g)	2 H402 15
Sidechain Supply (g)	3 H401 14
Sidechain Supply (-)	4 H403 13
Sidechain Supply (+)	5 12
Bypass Relay (NC)	6 H302 11
Bypass Relay (-)	7 H301 10
Bypass Relay (+)	8 9

To respective Audio I/O & Processing Circuits	
Leveling Tie	1 16
Sil Gate	2 15
DVG LED	3 H401 14
Level (In)	4 13
Compr. (In)	5 12
Level (Out) Hi	6 11
Level (Out) Lo	7 H302 10
I/O Board Ground	8 9

TEST POINTS

A	VCA out
B	Peak DC
C	Average DC
D	Compression DC
E	Leveling DC
G	Test Ground

POWER DISTRIBUTION

Sidechain Supply, (+15VDC)	V+
Sidechain Supply, (-15VDC)	V-
Sidechain Supply, Ground	↓
Logic Supply, (+5VDC)	V _L
Logic Supply, Ground	↓

NOTES

- All push-button switches are shown in depressed (button IN) position.
- Bipolar IC power connections are +15VDC to pin 8, -15VDC to pin 4, except ICs U304/404, U305/405, U306/406 and U307/407 which are connected as shown.

APHEX COMPELLOR™

CIRCUIT DIAGRAMS
CONTROL/DISPLAY BOARDS
Channel A
Channel B

APHEX SYSTEMS Ltd
No. Hollywood CA 91605

Date: October 1983
Drawn by: ITX/CK
Approved: _____
REV. _____
DRAWING NUMBER: 834-2

* INSERT .1 MFD IN SERIES W/ R432 + R434,
LOW END ROLLOFF BELOW 200HZ IN LEVELER CONTROL LOOP.

