

DOLBY LABORATORIES  
INSTRUCTION MANUAL

Dolby Laboratories Incorporated

U.S.A.: 731 Sansome Street, San Francisco, CA 94111  
Tel: (415) 392-0300; telex 34409; cables: Dolbylabs

U.K.: 346 Clapham Road, London SW9 9AP  
Tel: 01 720-1111; telex 919109; cables: Dolbylabs London

**WARRANTY INFORMATION:** Equipment manufactured by Dolby Laboratories is warranted against defects in materials and workmanship for one year from the date of purchase. There are no other express or implied warranties and no warranty of merchantability or fitness for a particular purpose.

During the warranty period Dolby Laboratories will repair, or at its option, replace components which prove to be defective, provided the unit is returned, shipped prepaid, to the manufacturer direct, or via an authorized distributor. Defects caused by modifications, misuse or accidents, and any further damage caused by inadequate packing for service return, are not covered by this warranty.

Dolby Laboratories' obligation is restricted to the repair or replacement of defective parts and under no circumstances shall Dolby Laboratories be liable for any other damage, either direct or consequential.

All request for repairs or information should include the unit serial number to assure rapid service.

## List of Contents

Section 1	Introduction
Section 2	Specifications
Section 3	Principles of Operation
Section 4	Installation: Controls and Connectors
Section 5	Level Standardization and Initial Calibration
Section 6	Operating Notes
Section 7	Interface Circuit Description
Section 8	Interface Servicing
Section 9	Cat. No. 66 Noise Reduction Module - Circuit
Rear of manual	Simplified Operating Instructions

SECTION 1  
MODEL 334  
FM BROADCAST UNIT  
INTRODUCTION

## 1.1 Introduction

The Model 334 broadcast unit is a professional processor having Dolby B-Type consumer noise reduction characteristics. The unit is designed for use in FM broadcasting, either for encoding of the transmitted signal or for decoding of the received signal for quality monitoring.

Use of the Dolby B-Type system provides attenuation of high frequency noise introduced between the transmitter and the receiver audio output - such as multiplex hiss and SCA high frequency interference. The area of satisfactory reception is thus increased significantly.

In addition to Dolby B-type encoding, the 334 unit modifies the transmission pre-emphasis time-constant to 25 us, allowing even greater signal-to-noise ratio improvements to be achieved through an increase of modulation level. A further quality improvement is achieved by the elimination of the need for high frequency limiting.

The Model 334 unit contains a built-in calibration oscillator to check calibration of Model 334 and transmitter. The broadcasting of this tone also allows consumers to calibrate add-on decoders. The parameters of the system are extremely stable; once aligned, the Model 334 requires no day-to-day maintenance.

The unit is self-contained and is supplied for mounting in a 19" (483 mm) rack.

SECTION 2  
SPECIFICATIONS

## Specifications - Model 334

Layout:	Two independent signal processors per unit.
Signal Connections:	One XLR input and output for each processor.
Input Circuit:	Bridging transformer, 10 k ohm balanced floating.
Output circuit:	Transformer, 20 ohms output impedance, balanced floating; will drive any load impedance from 200 ohms upwards.
Signal Levels:	Input and output levels adjusted by multi-turn potentiometers accessible from front of unit. Minimum input 350 mV for Dolby Level. Maximum output level +22 dB into bridging load; + 21 dBm into 600 ohms; + 20 dBm into 200 ohms.
Meters:	Front panel meters for level calibration. Dolby Level mark corresponds to 50% modulation ( $\pm$ 37,5 kHz deviation in FM transmitters).
Panel Controls:	Pushbuttons for selection of: a) NR in-out b) Dolby Tone c) Remote/local operation Toggle switch mode selector behind access plate for selecting encode or decode (quality off-air monitoring) mode.
Remote Control:	Five-pin XLR connector for remote control of NR in-out and Dolby Tone oscillator. Control effected by earthing terminals for NR out, oscillator on. Maximum resistance in earthing line, 1 k ohm.
Overall frequency response:	(encode-decode) 30 Hz - 15 kHz, $\pm$ 1 dB.
Total harmonic distortion:	At + 4 dBm, less than 0,1% at 1 kHz; less than 0,2% from 40 Hz to 20 kHz.

Encoding characteristic:	Dolby B-Type characteristics: + 3 dB at 500 Hz + 6 dB at 1000 Hz + 10 dB from 4 kHz upwards followed by filter to reduce transmitter time-constant to 25 usec. With noise reduction switched out, system becomes a line amplifier (time-constant compensation is linked to noise reduction switch).
Decoding characteristic:	Dolby B-Type characteristics preceded by filter to convert output of standard 75 (50) usec receiver to 25 usec.
Multiplex filter:	Built-in multiplex filter with 35 dB notch at 19 kHz, with low pass characteristic giving 20 dB attenuation at 38 kHz and 45 dB at 80 kHz. Filter response below 15 kHz, $\pm 0.5$ dB.
Overall noise level:	Better than 80 dB (unweighted or according to CCIR/ARM) below Dolby Level.
Encode noise level:	Better than 75 dB below Dolby Level.
Crosstalk:	Better than - 60 dB between channels at - 1 kHz, and - 50 dB at 10 kHz and above.
Signal delay:	27 usec.
Phase:	Difference between channels less than $5^{\circ}$ , 20 Hz to 12 kHz, overall encode-decode.
Matching between units:	Better than 1 dB at any level and any frequency.
Stability:	System is highly stable - does not require routine alignment.
Operating temperature:	- 20°C to 50°C.
Construction:	Plug-in B-Type noise reduction module (Cat. No. 66). Level setting potentiometers and mode changeover switch accessible through front panel. Fibre-glass printed circuit, solid state devices throughout.

Finish: Steel case, grey stoved plastic textured finish; front panel clear anodized with black characters.

Size: 44 x 483mm rack mounting ( $1\frac{3}{4}$ " x 19"). Maximum projection behind mounting surface - 228 mm (8  $\frac{15}{16}$ " ). Maximum projection in front of mounting surface - 22 mm ( $\frac{7}{8}$ " ).

Weight: 5.5 kg (12 lbs).

Power requirements: Unit is designed for operation from centrally - switched power source. Power cable provided. 100-130 V and 200-260 V, 50-60 Hz single phase, 13 VA.



### 3.1 B-Type Noise Reduction System

In sound recording or transmission systems the high audio frequencies are often pre-emphasized during recording and de-emphasized during reproduction in order to improve the signal to noise ratio. However, the equalization characteristic must be chosen such that even with high level, high frequency signals there are no detrimental effects. Therefore the allowable boost with fixed equalization is not as great as it might be for optimum utilization of the recording medium. For example, recording an instrument such as a piano or violin does not usefully load the channel over the whole audio spectrum, and thus high frequency noises are particularly noticeable during reproduction.

It is clear that the situation could be improved with a more flexible equalization method. The Dolby B-Type noise reduction system provides a characteristic, controlled by the incoming signal, which achieves optimum loading of the recording or transmission channel under all signal conditions. During reproduction a complementary characteristic is applied which restores all frequency components to their correct amplitudes and in the process attenuates noise.

In consumer tape and broadcast applications the main noise problem, hiss, can be handled inexpensively but adequately by a single high frequency noise reduction band. The necessary characteristics are obtained by splitting the input signal into two paths, one direct path and one passing only high frequencies through a low-level compressor circuit. The encoded signal is produced by adding together the output of the compressor to the direct path output (Fig. 3.1).

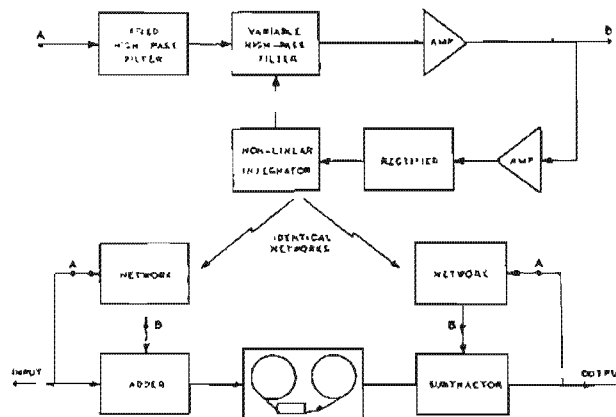

Block diagram of B-type noise reduction system.

Fig. 3.1

While the compressor has a compression characteristic which by itself is more like that of a limiter, the overall law produced at the output can be described as compression (Figs. 3.2, 3.3).

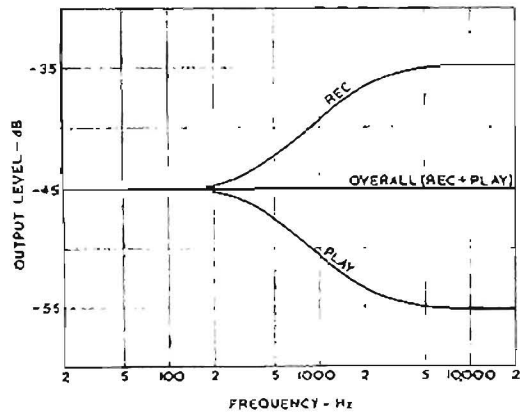

Low-level frequency response characteristics of record and play processors.

Fig. 3.2

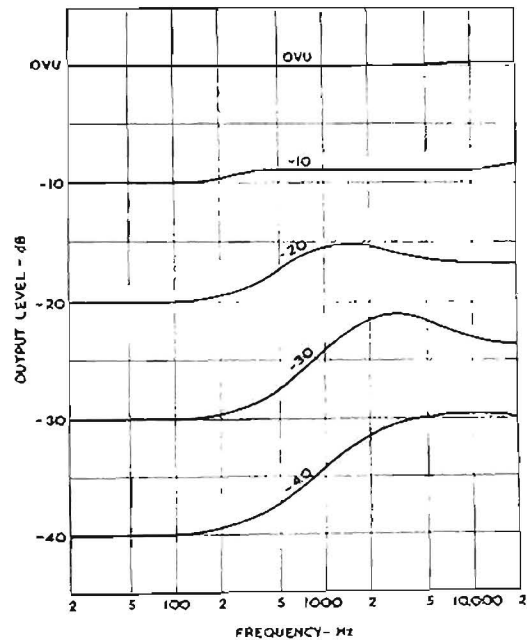

Encode processor characteristics.

Fig. 3.3

During playback or reception, the encoded signal is processed in a complementary way. The decoding compressor is identical to that used in the encoding process, but the side chain is connected such that its output is subtracted from the input to the processor. The decode processor thus acts as an expander, and its characteristic is such as to mirror the characteristics of the encode processor precisely; every change in the signal during encoding is matched by an equal and opposite change in decoding. In this way the signal leaving the B-Type unit in the decode mode is identical in all respects to that entering prior to encoding.

Noise produced by the tape or broadcasting and reception channel is added to the signal while it is in the B-encoded condition, in which all low-level components have higher than normal amplitudes. During decoding, the low-level components are attenuated, thereby restoring the signal to its original condition; the noise contribution is therefore attenuated by the same amount.

The complementary properties of the Dolby system are of special significance where quadrasonic matrix encoded signals are to be handled, whether in the form of recordings or FM transmissions. It should be noted that in the Dolby encoding-decoding process there are no overall changes in signal dynamics, frequency response, phase response, or transient response. While there are changes in all of these parameters in the encoded signal, the decoding process compensates precisely for the changes introduced. The phase errors introduced in encoding-decoding are typically less than five degrees at all frequencies and levels, which results in minimal interference with the quadrasonic matrix encoding-decoding process.

It should be noted that in common with all electronic circuits, the 19 kHz input filter in the Model 334 produces a signal delay, 27 usec in this case, which is constant with frequency. Phase measurements made between input and output of the Model 334 are therefore invalid unless this delay is taken into account.

### 3.2 FM Broadcast Application

Because of the extra information channels added since its original monaural introduction, FM broadcasting has been steadily degraded in quality during the past two decades. Stereo broadcasting produces the greatest decrease in quality; the multiplex stereo system reduces the usable dynamic range by over 20 dB. The increased noise level is predominantly high frequency in character.

In many parts of the world subcarrier systems are used to convey added information often not available to the main programme listener. Examples are the SCA (subsidiary communications authorization) system in the USA for store-casting and various experimental dual language programmes in Europe. In many receivers, filtering after the detector stage is less than perfect, allowing the added subcarrier to interfere with the stereo subcarrier in the multiplex decoder. Such interferences are audible as high frequency 'monkey-chatter'.

The use of the Dolby B-Type noise reduction system in FM broadcasting achieves a significant improvement in high frequency signal to noise ratio and an alleviation of the specific noise problems mentioned above.

### 3.3 Time-constant Modification

An outstanding problem with the present FM transmission system is the excessive high frequency pre-emphasis which is employed. The 75 usec pre-emphasis and de-emphasis time-constant now used in US broadcasting and the 50 usec time-constant used in European and Japanese broadcasting have 3 dB boost points at about 2 kHz and 3 kHz, respectively, which result in 10 kHz signal boosts of approximately 14 dB and 10 dB respectively. With contemporary microphones and signal treatments, these amounts of pre-emphasis are unacceptable because they result in transmitter overmodulation or the requirement for a reduction of level or the use of signal-degrading treatments such as high frequency limiting. Existing time-constant standards are thus in conflict with the original FM objective of providing wide-range, low distortion transmissions with a high signal to noise ratio.

The possible high frequency overmodulations resulting from the use of the 50 usec and 75 usec time-constants are usually mitigated in practice by the use of special limiter circuits which operate either over the whole frequency band or at high frequencies only. However, broadcasters who try to maintain high standards

are usually reluctant to employ limiting devices or to allow them to operate to any appreciable extent.

If high frequency limiting is to be avoided, then the danger of overmodulation at high frequencies leads directly to the use of a lower overall modulation level. From consideration of the spectral distribution of peak energy in the programme material it can be shown that for the 50 usec case the midband modulation level must be reduced by about 5.3 dB (to 54% modulation) and that in the 75 usec case the level must be reduced by about 8.3 dB (to 38% modulation). For both the 50 usec and 75 usec time-constants the midband undermodulation required with programme material containing high level, high frequency components is significant and represents a wasteful utilization of channel capacity, resulting at the receiver in a signal to noise ratio which does not represent the best usage of the FM transmission system.

Further investigation has shown that the maximum pre-emphasis time-constant which can be used without restricting low and mid-frequency modulation levels is about 25 usec. Such a large reduction in transmission time-constant, introduced by itself, results in an unacceptable attenuation of high frequencies during reception by receivers having the old time-constant. This attenuation can, however, be subjectively compensated by the use of Dolby B-Type compression during transmission. The Model 334 incorporates an effective 25 usec time-constant, switched automatically when B-Type compression is employed.

With B-Type compression and a 25 usec transmission time-constant, the listener with conventional receiving equipment hears a compatible signal. The reduced time-constant allows the broadcaster to use an increased modulation level with many types of programme material.

Listeners equipped with receivers having a 25 usec de-emphasis facility, in conjunction with B-type expanders, have the advantages of a signal-to-noise ratio improved by more than 10 dB together with a fully corrected signal.

In May 1974, The Federal Communications Commission (FCC) approved the use of Dolby B-type encoding coupled with an effective time-constant of 25 usec. The Model 334 complies in all respects with FCC requirements. Noise reduction should be switched out during proof of performance tests.

4.1

SECTION 4  
INSTALLATION  
CONTROLS AND CONNECTORS

The Model 334 is designed for Dolby B-Type encoding of FM stereo broadcasts and for quality monitoring of off-air signals.

The block diagram at the end of this section shows how the noise reduction system fits into an FM broadcasting chain. Each Model 334 contains two independent processor channels with common function switching.

When used to encode transmissions, the Model 334 should be considered to be part of the transmitting chain, as opposed to a studio tool. However, it should precede the stereo multiplex encoder and transmitter protection-type limiter.

The change in time-constant is effected by a network in the Model 334, switched automatically with selection of Dolby B-Type encoding (front panel pushbutton NR in). No modifications to the transmitter pre-emphasis circuits are required; the combination of normal transmitter pre-emphasis plus Model 334 conversion network produces an effective 25 usec time-constant.

#### 4.2 Installation

The Model 334 is designed for mounting in a standard 19" rack. However, its position is not critical and it can be operated in any plane.

- a) Check that the power voltage switch on the rear of the unit is in the correct position.
- b) Make signal connections to rear-mounting Cannon XLR's. For 3-pin XLR connectors, pin 1 is earth, pins 2 and 3 are the balanced-floating winding of the input or output transformer, with pin 2 as the 'low' side and pin 3 as the 'high' side for standardized phasing. For unbalanced operation, pin 2 should be connected to earth; pin 3 is signal.
- c) Connect signal phase power through three-pin moulded plug and lead supplied. If the power plugs on the cables are changed for another type, the following wiring convention should be observed (for cables supplied with units).

U.S. style            Power: L, black; N, white; Earth: green

Continental style   Power: L, brown; N, blue; Earth: yellow/green

- d) Check position of mode toggle switch, under front access panel (encode for use in transmission, decode in reception).
- e) Check position of rear-mounted input termination switch (fitted after Ser. No. 35). If true 600 ohm termination required, slide switch to left. For modern practice of low impedance outputs and bridging inputs, slide switch to right.
- f) Carry out the level adjustment procedure given in Section 5, Level Standardization and initial Calibration.

#### 4.3 Remote Operation

Remote facilities are provided for the operation of Dolby Tone and use of the Dolby mode. To utilize the remote facilities, the front panel pushbutton must be depressed.

## a) Dolby Tone

The Dolby Tone oscillator may be activated by connecting Pin 2 of the five pin XLR connector to earth, by means for example of a normally-open push-button at the end of the remote cable. The cable can be extended for long distances subject to the requirement that the total resistance in the cable is less than 1k ohm; standard two conductor cable is suitable. An earth connection is available on pin 1 of the five pin XLR and should be used; do not use an earth at the remote position.

## b) Noise Reduction In-Out

Earthing pin 5 of the five pin XLR connector removes the noise reduction action and the time-constant change; the unit then has a flat frequency response. Two conductor cable may be used, provided the total resistance in the cable is less than 1k ohm. An earth connection is available on pin 1 of the five pin XLR- do not use an earth at the remote position.

4.4 High Frequency Limiters

With a 75 usec pre-emphasis characteristic, the need to modulate the transmitter efficiently at low frequencies in the interest of good coverage often produces over-deviation at high frequencies. The effects of such over-deviation are often lessened by the use of special processing units designed to prevent modulation levels exceeding 100% at any frequency. Notable examples are the CBS Volumax and the Gates FM Top Level or Limiter. The principle of these devices is to pre-emphasize the signal passing to the limiter circuit which then limits at the 100% level. The limiter is followed by a de-emphasis network, and the signal is passed to the transmitter.

The use of the Model 334 reduces the necessity for such treatment. If such processing equipment is continued in use, it should precede the Model 334. The circuits associated with high frequency dynamic limiting must be changed so that they operate as if for a 25 usec pre-emphasis.

In some existing installations it may be inconvenient to place such processing units before the Model 334 (they may be installed at the transmitter for example). In these circumstances, the processing unit may remain after the Model 334; the limiters may be left unchanged as for 75 usec pre-emphasis.

For the preferred position (before the Model 334), detailed changes for some commercially available devices are listed below:

A: CBS FM Volumax Model 410 or 411 (conversion kit available from CBS or Dolby Laboratories)

If the Volumax is to be used in the non-preferred position (after the Model 334) no changes are required, and no realignment is necessary. However, a check should be made to ensure that the wideband limiting action is not severe, and that the setting of the input control is such that the meter only occasionally deflects.

For the preferred installation position (before the Model 334), proceed as follows:

1. Control Board
  - a) Change capacitors C200 and C201 (0,0015 uF) to 470 pF.
  - b) Parallel resistors R208 and R209 (10 Kohm) with 2000 pF capacitors.
2. AGC Board No. 1
  - c) Change capacitors C209 and C210 (0.0033 uF) to 1200 pF.
3. Output Board
  - d) Change inductor L200 (50 mH) to 17.5 mH.
  - e) Change capacitor C204 (0.12 uF) to 0.047 uF, 5%, 50 V min.
  - f) Change resistor R263 (200 ohm) to 0 ohm (insulated jumper).
4. Replace boards and cover. No calibration adjustments are necessary.

B: CBS Volumax Model 4100 or 4110 (conversion kit available from CBS or Dolby Laboratories)

If the Volumax is to be used in the non-preferred position (after the Model 334) no changes are required, and no realignment is necessary. However, a check should be made to ensure that the wideband limiting action is not severe, and that the setting of the input control is such that the meter only occasionally deflects.

For the preferred installation position (before the Model 334) proceed as follows:

1. Remove boards A1 and A4.
2. Change capacitors C1 (1200 pF) to 390 pF, 2%.
3. Change capacitors C9 (0.12 uF) to 0.047 uF, 5%, 50 V min.
4. Change inductor L1 (50 mH) to 17.5 mH.
5. Replace boards and cover. No calibration adjustments are necessary.

C: Gates FM Solid Statesman (obtain parts from local supply house)

If the Solid Statesman is used in the non-preferred position (after the Model 334) no changes are required. However, a check should be made to ensure that the wideband limiting action is not severe, and that the setting of the input control is such that the meter only occasionally indicates compression is occurring.



For preferred installation position (before the Model 334) proceed as follows:

1. Modify both units in a stereo installation.
2. Change capacitors C9 and C17 (2200 pF) to 750 pF, 1%.
3. Change capacitor C10 (100 pF) to 56 pF, 5%.
4. No calibration adjustments are necessary.

IT IS SUGGESTED THAT FIXINGS FOR SUPPORTS ARE ADJUSTABLE TO ALLOW FOR POSSIBLE TOLERANCE BUILD-UP ON REAR DOWEL CENTRES.

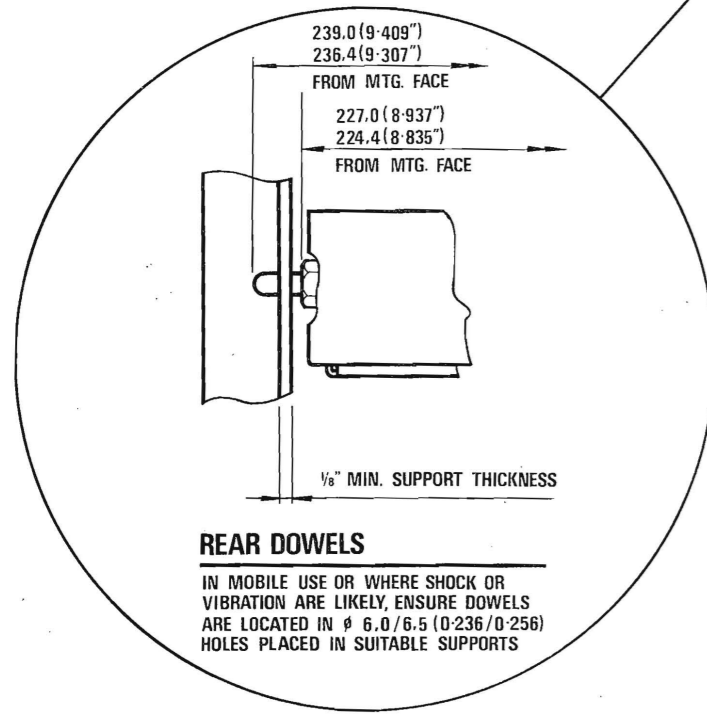
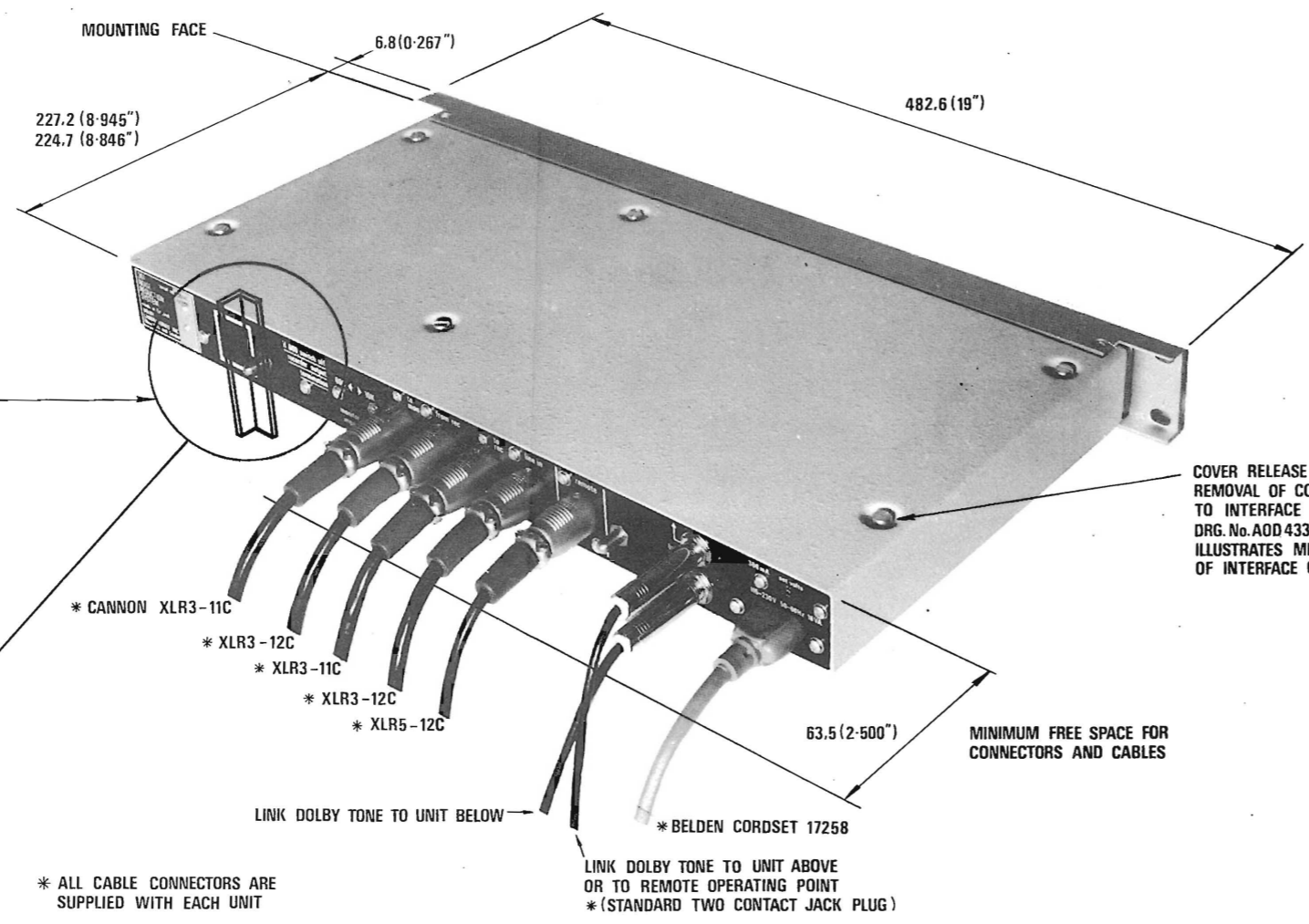

\* ALL CABLE CONNECTORS ARE SUPPLIED WITH EACH UNIT

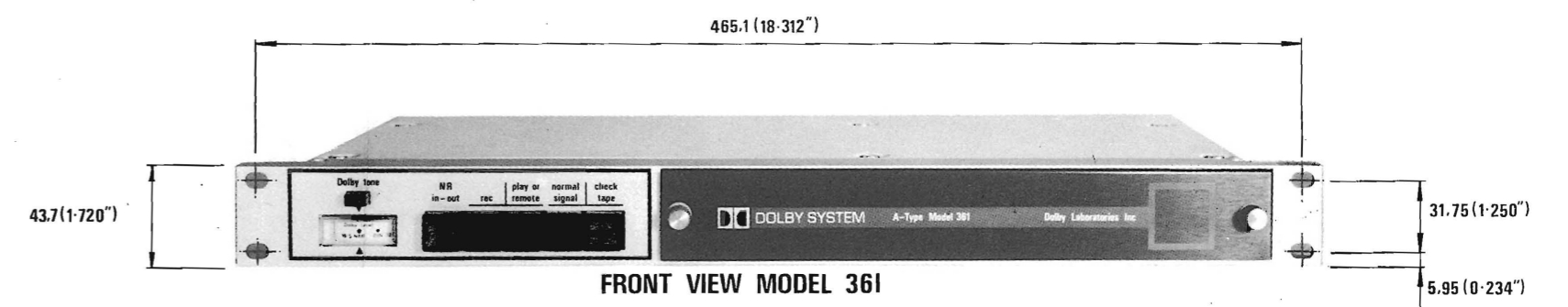
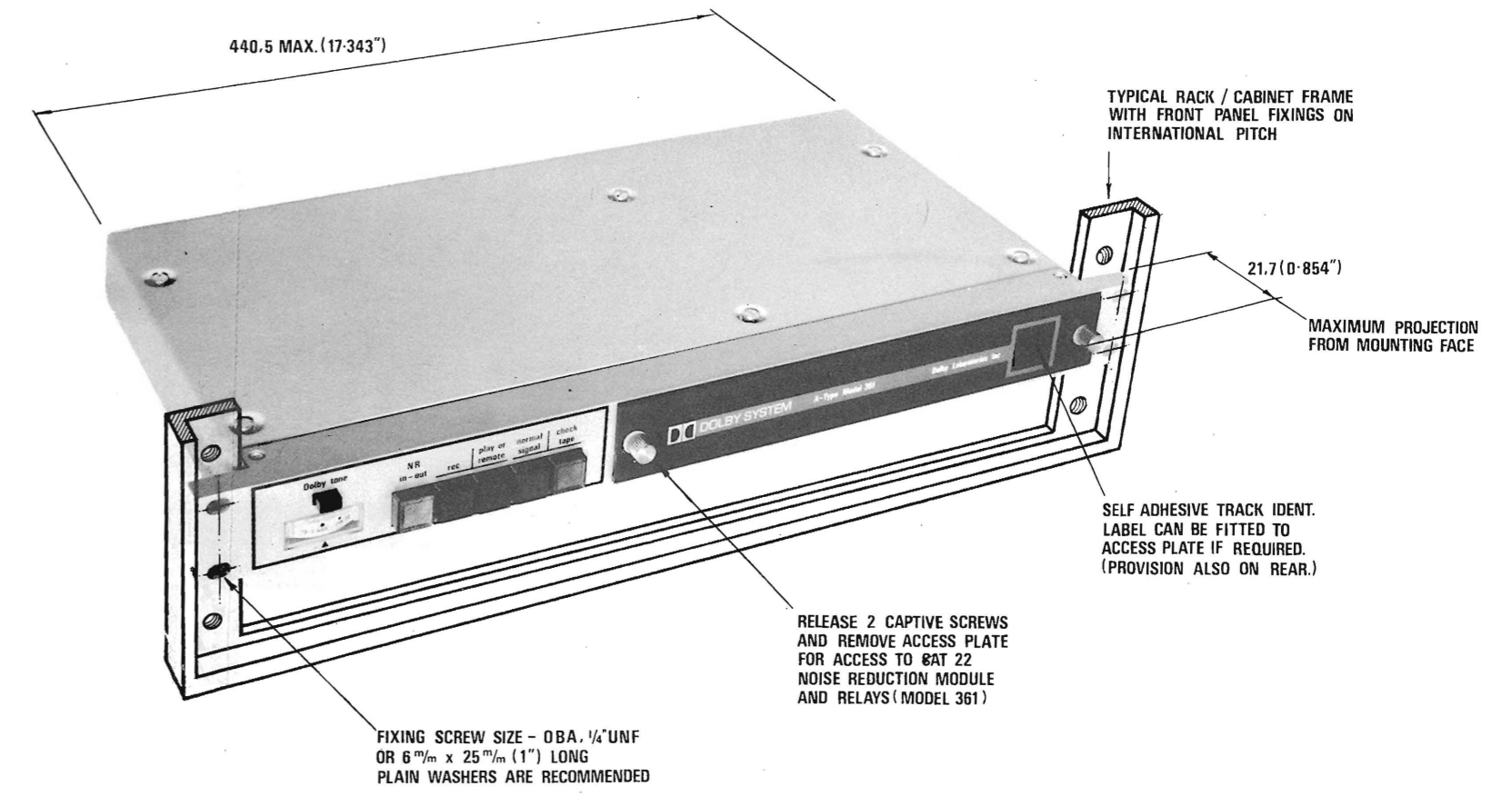
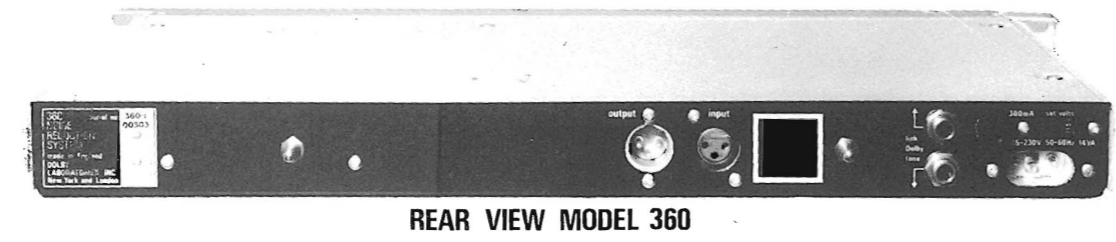
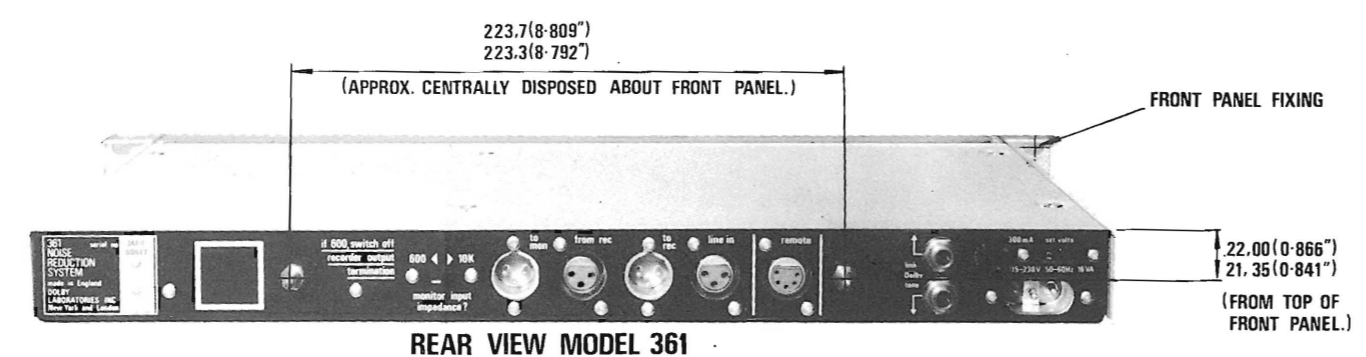

**INSTALLATION INFORMATION — 330 and 360 Series**  
All dimensions in millimetres auxiliary dimensions in inches Drg. No. A0D 495

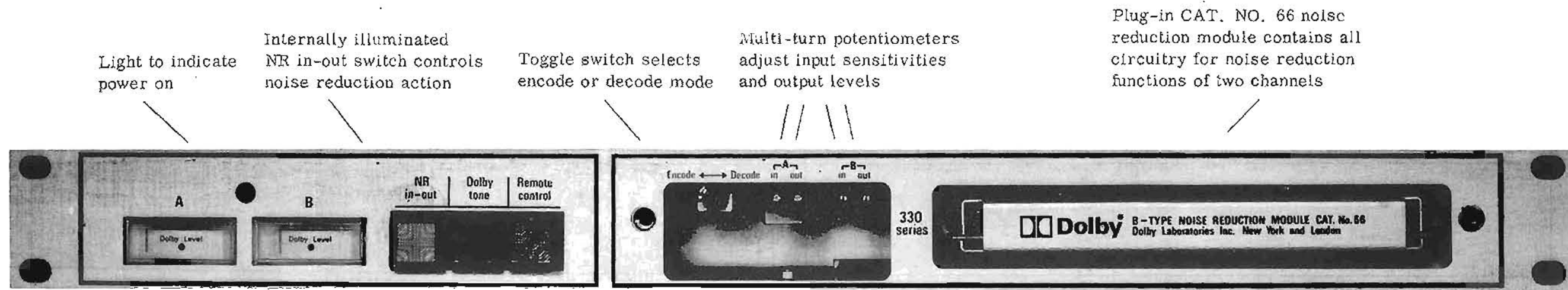

M1 M2

Meters to assist in calibration

Dolby tone button for operation of internal oscillator provides Dolby level signal for identification and calibration purposes

Switch permits remote control of NR in-out and Dolby tone

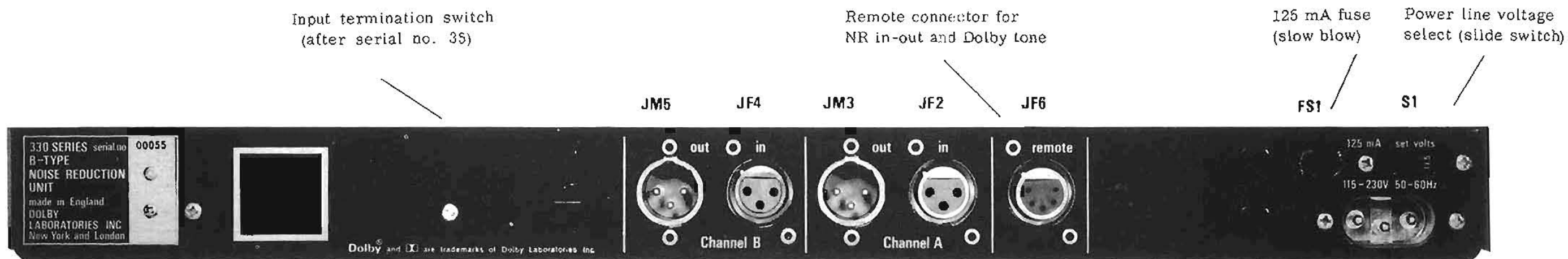

Space for channel/programme identification label

Channel B audio connectors

Channel A audio connectors

## BROADCASTING

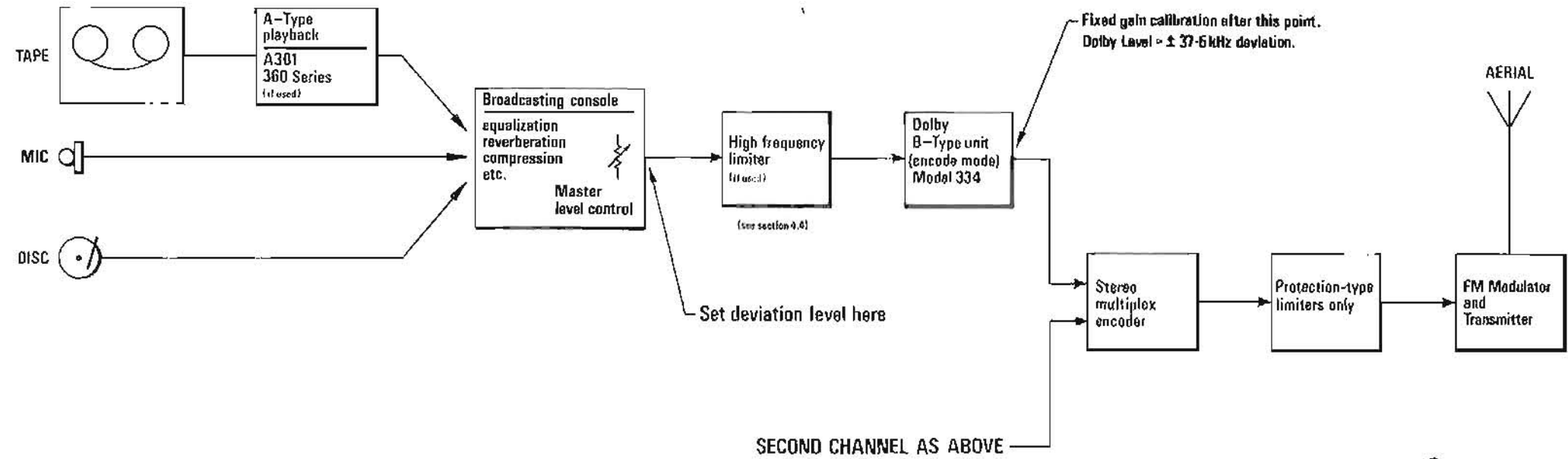

## RECEPTION

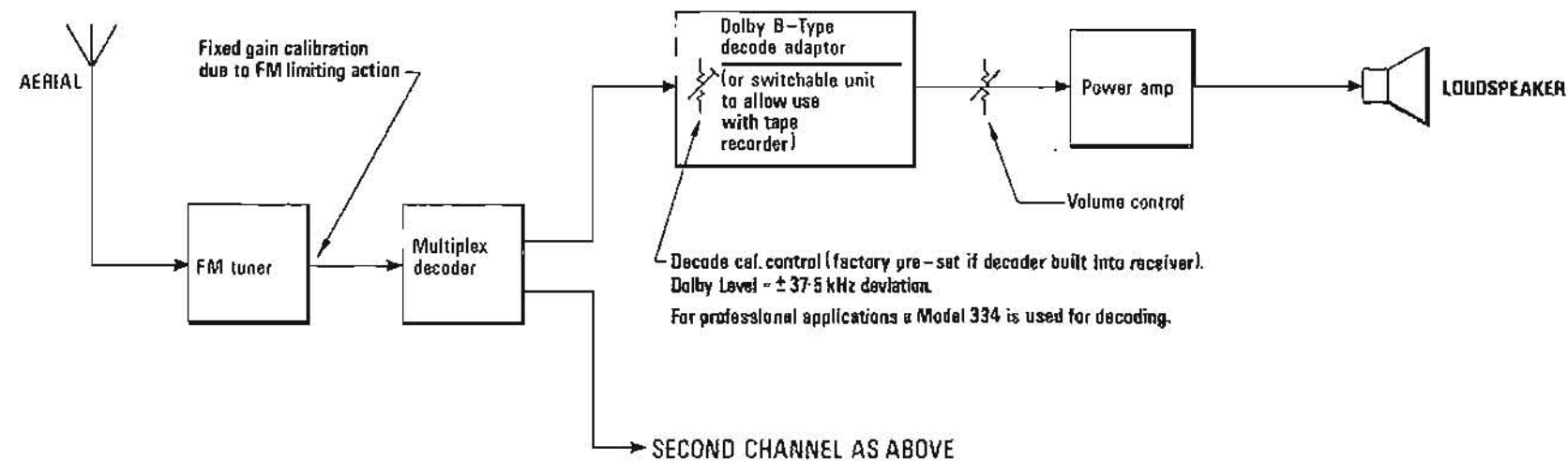

SECTION 5

LEVEL STANDARDIZATION AND INITIAL CALIBRATION

### 5.1 Standardization

Correct operation of the Dolby B-Type noise reduction system is dependent on only one basic requirement - that the signal voltage in any decoding processor should be the same (within 2 dB) as that in the encoding processor. However, the requirement for interchangeability of decoders and standardization of broadcasts imposes a further restriction - that the signal level in the noise reduction system should be related to FM deviation.

In order to correlate the various voltage levels and FM deviations used in the broadcasting chain, from transmitter through to receiver, the concept of "Dolby Level" is employed. Dolby Level bears a fixed amplitude relationship to the noise reduction compression and expansion parameters. In the case of the B-Type noise reduction system, Dolby Level is defined at 400 Hz.

For standardization of Dolby-processed FM transmissions, Dolby Level is expressed in terms of FM deviation. Decoders are factory-calibrated (when built-in) or adjusted using the Model 334 Dolby Tone which is transmitted periodically. The limiting action of FM receivers ensures that the decoder always remains correctly calibrated.

Dolby Level is defined as a peak audio deviation of 50% of the total transmitter allowable capability. This corresponds, for standard FM broadcasting systems, to a deviation of  $\pm 37.5$  kHz. An important consideration in the definition of Dolby Level is that the signal output from all receivers (that is, the voltage level at the calibration or metering point in the Dolby decoder) must remain constant for a transmitted Dolby Tone, regardless of mode of receiver or type of FM transmitting station, (mono, stereo, SCA or 1- channel). The total signal at the transmitter will be made up of the audio component plus several other components, ranging from stereo multiplex pilot tones to tones used to control the functioning of unattended transmitters.

Thus, in the ordinary stereo case, the total percentage deviation will be 50% audio plus 9% pilot, or 59%. Modulation meters at the transmitter, or on stereo signal generators used to calibrate tuners incorporating Dolby B-Type FM decoders, will indicate 59%.

For a stereo station which also has an SCA transmission, the total deviation for Dolby Level will be 50% audio plus 9% pilot + 10% SCA, or a total transmitter percentage deviation of 69%. A monophonic station will have a total deviation of 50%, and a monophonic station with SCA, 60%.

### 5.2 Adjustment of unit when used in encoding mode

1. Check that mode switch (under access panel) is in encode mode.
2. Select NR in.
3. Note indicated modulation level of transmitter with no programme present (for example 9% for a stereo station, produced by pilot, or 19% for a stereo station with SCA).

4. Press Dolby Tone button.
5. Adjust channel A output potentiometer (under access plate) such that the modulation level of the transmitter is 50% plus previously noted figure (i. e. 59% for a stereo station, 69% for a stereo station with SCA).
6. Increase channel B output potentiometer until the modulation meter just increases over the level indicated for channel A and back-off slightly. This will ensure modulation levels are identical on both channels. Check by momentarily unplugging the output XLR connectors one at a time. The modulation levels should be identical for each channel separately driving the transmitter.
7. Adjust both input potentiometers for required relationship between input line level and transmitter modulation level.

### 5.3 Adjustment of unit when used in Quality Monitoring (decoding) Mode

1. Connect to suitable off-air receiver.
2. Check that mode switch (under access panel) is in decode position.
3. Select NR out.
4. Transmit Dolby Tone from an encode Model 334.
5. Adjust channel input potentiometers to give a reading of Dolby Level on both channel meters.
6. Adjust channel output potentiometers to give required relationship between transmitter modulation level and output line level.
7. Replace access plate; select NR in.

SECTION 6  
OPERATING NOTES



## 6.1 FM Broadcasting

The step-by-step basic operational procedure for FM broadcasting is at the end of this manual for quick reference. In addition to these routine procedures, the following points can be made. Refer to the general layout at the end of Section 4.

If limiters or compressors are used between the studio and transmitter in order to ensure that the transmitter does not overdeviate, these devices should be installed before the Model 334. The pre-emphasis time-constant changing network in the Model 334 reduces the danger of transmitter over-modulation at high frequencies; since the Dolby B-Type characteristics are such that only low level high frequencies are boosted, the combination of Dolby processing with an effective 25 usec pre-emphasis retains this advantage. Instantaneous clipping amplifiers used at the transmitter as protection devices are the only signal processors which should be allowed to follow the Model 334.

To ensure that listeners equipped with Dolby B-Type decoders can calibrate them correctly, a short transmission of Dolby Tone should be made periodically. A 5-10 sec transmission three times a day is satisfactory. The necessity for Dolby Tone transmissions will of course gradually disappear when present add-on decoder units are replaced by decoders built into receivers.

## 6.2 Quadraphonic Broadcasting

For broadcasting four-channel (quadraphonic) material in which four discrete channels are employed for each programme, two Model 334 units should be used; normally these units should precede the four channel encoder. For matrix-type four-channel encoding systems, only a single Model 334 is used, as in normal two-channel stereo. The four channel matrix system encoder should always precede the Model 334 unit, and during reproduction, the four channel decoder should follow the B-Type decoder unit.

Other than ensuring that the encoding and decoding are accomplished in the correct order, there are no special problems in the use of the B-Type noise reduction system with any of the four channel systems known at the moment; the noise reduction system and the four-channel system operate independently.

## 6.3 Use of time-constant modification

Section 3, sub-section 3.3 describes the problems inherent in the use of 50 or 75 usec time-constants in FM broadcasting. The use of a 25 usec time-constant in conjunction with Dolby B-Type encoding greatly reduces these problems, allowing mid-band modulation to be increased with many types of programme material. Listeners with conventional receivers are provided with a compatible signal but with the reception advantages of an increased modulation level. Listeners with a 25 usec de-emphasis time-constants and B-Type expanders have the dual advantages of increased level and lower noise.

The time-constant change is achieved without any modification to the transmitter by a special frequency-correction network in the Model 334. The combination of this network and the time-constant network in the transmitter produces an effective 25 usec characteristic. The network is switched in automatically by the NR in-out front panel push button or by the remote control of noise reduction.

The time-constant used in any associated limiter (for example the CBS Laboratories FM Volumax) should be changed to 25 usec for Dolby B-Type broadcasting. Details of these modifications are given in subsection 4.4.

#### 6.4. Remote Operation

A front panel button is provided for selection of remote operation of certain modes. With this button depressed, the Dolby Tone oscillator may be operated and the Dolby B-Type encoding mode cancelled. These remote operations are effected by grounding the appropriate pins on the rear-mounted five-pin XLR connector.

# Dolby 334 FM Broadcast Unit

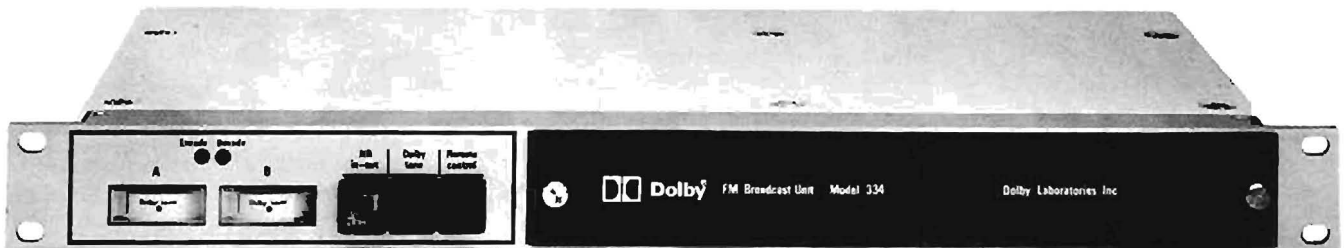

The Dolby 334 provides FM broadcasting stations with encoding of stereophonic signals for Dolby B-Type noise reduction and with simultaneous conversion of the standard 75 microsecond pre-emphasis to an effective pre-emphasis of 25 microseconds. Such transmissions are approved in the USA by the Federal Communications Commission as compatible with normal reception equipment.

All listeners benefit, depending on previous station practice, either from an increase in station signal level or a reduction in high frequency compression or limiting, or by a combination of both. For owners of equipment incorporating the Dolby B-Type noise reduction circuit, which is in widespread use, there is a further gain arising from the substantial improvement in signal-to-noise ratio provided by the circuit.

A full description of this method of broadcasting is contained in the following two reprints, available upon request from Dolby Laboratories, as is the relevant document from the FCC.

D P Robinson, 'Dolby B-Type Noise Reduction for FM Broadcasts,' *J. Audio Eng. Soc.*, vol 21, pp 351-356 (June 1973).

R M Dolby, 'Optimum use of Noise Reduction in FM Broadcasting,' *J. Audio Eng. Soc.*, vol 21, pp 357-362 (June 1973).



**Model 334 Specifications**

**Layout**

Two independent signal processors per unit.

**Signal connections**

One XLR input and output for each processor.

**Input circuit**

Balanced floating transformer. Input impedance; 10 kohm or 600 ohm, selected by rear-mounted switch.

**Output circuit**

Transformer, 20 ohms output impedance, balanced floating; will drive any load impedance from 200 ohms upwards.

**Signal levels**

Input and output levels adjusted by multi-turn potentiometers accessible from front of unit. Minimum input 350 mV for Dolby Level. Maximum output level +22 dB into bridging load; +21 dBm into 600 ohms; +20 dBm into 200 ohms.

**Meters**

Front panel meters for level calibration. Dolby Level mark corresponds to 50% modulation ( $\pm 37.5$  kHz deviation in FM transmitters).

**Panel controls**

Pushbuttons for selection of:

- a) NR in-out
- b) Dolby Tone
- c) Remote/local operation

Toggle switch mode selector behind access plate for selecting encode or decode (quality off-air monitoring) mode.

**Remote control**

Five-pin XLR connector for remote control of NR in-out and Dolby Tone oscillator. Control effected by earthing terminals for NR out, oscillator on. Maximum resistance in earthing line, 1k ohm.

**Overall frequency response**

(encode – decode)  
30 Hz – 15 kHz,  $\pm 1$  dB.

**Total harmonic distortion**

At  $-4$  dBm, less than 0.1% at 1 kHz; less than 0.2% from 40 Hz to 20 kHz.

**Encoding characteristic**

Dolby B-Type characteristics:  $-3$  dB at 500 Hz;  $-6$  dB at 1000 Hz;  $-10$  dB from 4 kHz upwards, followed by filter to reduce transmitter time-constant to 25  $\mu$ sec. With noise reduction switched out, system becomes line amplifier (time-constant compensation is linked to noise reduction switch).

**Decoding characteristic**

Dolby B-Type characteristics preceded by filter to convert output of standard 75 (50)  $\mu$ sec receiver to 25  $\mu$ sec.

**Multiplex filter**

Built-in multiplex filter with 35 dB notch at 19 kHz, with low pass characteristic giving 20 dB attenuation at 38 kHz and 45 dB at 80 kHz. Filter response below 15 kHz,  $\pm 0.5$  dB.

**Overall noise level**

Better than 80 dB (unweighted or according to CCIR/ARM), below Dolby Level. Encoding signal-to-noise ratio 75 dB.

**Crosstalk**

Better than 60 dB between channels at 1 kHz, and 50 dB at 10 kHz and above.

**Signal delay**

27  $\mu$ sec.

**Phase difference between channels**

Less than 5°, 20 Hz to 12 kHz, overall encode-decode.

**Matching between units**

Better than 1 dB at any level and any frequency.

**Stability**

System is highly stable – does not require routine alignment.

**Operation temperature**

20°C to 50°C.

**Construction**

Plug-in B-Type noise reduction module (Cat. No. 66), level setting potentiometers and mode changeover switch accessible under front panel. Fibreglass printed circuits, solid state devices throughout.

**Finish**

Steel case, grey stoved plastic textured finish; front panel clear anodized with black characters.

**Size**

44 mm x 483 mm rack mounting (1 3/4 in x 19 in). Maximum projection behind mounting surface: 228 mm (8 15/16 in). Maximum projection in front of mounting surface: 22 mm (7/8 in).

**Weight**

5.5kg (12lbs).

**Power requirements**

Unit is designed for operation from centrally-switched power source. Power cable provided. 100–130 V and 200–260 V, 50–60 Hz single phase, 13 VA.

**Dolby**<sup>®</sup>  
Dolby and the double-D symbol are trade marks of Dolby Laboratories Inc.  
**Dolby Laboratories Inc**

731 Sansome Street  
San Francisco CA 94111  
Telephone (415) 392-0300  
Telex 34409  
Cable Dolbylabs

346 Clapham Road  
London SW9  
Telephone 01-720 1111  
Telex 919109  
Cable Dolbylabs London

MODEL 334 FM BROADCAST UNIT  
SIMPLIFIED OPERATING INSTRUCTIONS

A. Initial Calibration of Encoder

1. Remove front cover plate. Set unit to encode mode, NR on.
2. Feed Model 334 outputs to FM multiplex encoder inputs. Ensure that no limiters or compressors follow the Model 334 (except for instantaneous protection clippers).
3. Press Dolby Tone oscillator button. Adjust Model 334 channel A and B output potentiometers to give 50% transmitter deviation ( $\pm 37.5$  kHz). Total modulation meters in stereo stations will indicate 59% (50% audio + 9% pilot), and in stereo stations with SCA 69% (50% audio + 9% pilot + 10% SCA).
4. Release Dolby Tone oscillator button and adjust channel A and B input potentiometers to give required modulation level.

B. Programme Transmission

1. Programme may be transmitted conventionally, or in 25 usec Dolby FM mode by appropriate push button selection. This change may also be effected remotely. Note that the transmitter pre-emphasis remains at 75 usec. The time-constant change is effected by a network inside the Model 334 unit.
2. The change to 25 usec pre-emphasis in the Dolby FM mode allows broadcasters to raise the transmitted modulation level with many types of programme material. To achieve this increase, the 334 channel input potentiometers may be adjusted or the sending level from the console into the unit may be increased. Do not adjust the Model 334 output level potentiometers or the gains after the 334.

C. Notes

1. Until B-Type decoders are more widespread in receivers, Dolby Tone should be transmitted periodically to allow listeners to adjust or check level on their add-on decoders. Suggested times are 12.00 hrs, 18.00 hrs, and 23.00 hrs, for 5-10 sec during station breaks. Press Dolby Tone button on Model 334 unit to transmit tone. For oscillator to operate, NR must be 'on'. Dolby Tone may also be operated remotely.
2. When FM broadcast stations conduct proof of performance tests (FCC rules, Section 73. 254), Dolby encoding should be removed by selecting NR out.

D. Initial Calibration of Model 334 used as Decoder for Quality Monitoring

1. Remove front cover plate, Select decode mode and NR in.
2. Connect inputs to output of high quality conventional (i. e. 75 or 50 usec de-emphasis time-constant) off-air receiver. Connect outputs to normal monitoring system.
3. Tune receiver to any station transmitting Dolby Tone. Select NR out to remove NR action in decoder. Adjust Model 334 channel A and B input potentiometers so that the meters on Model 334 indicate Dolby Level.
4. Adjust channel A and B output potentiometers for required line level.
5. Select NR in. Replace front cover plate.

SECTION 7  
INTERFACE CIRCUIT DESCRIPTION

## 7.1 Interface Chassis

The interface assembly provides for all interface requirements between the Cat. No. 66 B-Type noise reduction module (NRM) and the tape recorder, FM transmitter, or other equipment with which the noise reduction system is used. As well as providing a housing for the module, the interface includes a power supply, two meters and associated circuitry, input and output potentiometers, and pushbuttons and logic circuits to control and indicate the functions of the module. Most of the components are mounted on a single printed circuit board, the physical layout of which can be seen on the drawings in Section 8, Interface Servicing. The interface circuit drawing (AOC 1299) is at the rear of this section, and may be folded out clear of the text for reference.

## 7.2 Power Supply

AC power is fed to a double primary transformer (T1) which can be set for 115 V or 230 V operation by means of a screwdriver-slot slide switch (S1) mounted on the rear of the unit. In the 230 V position the unit will operate on any power line voltage from 180 to 250 V, and over an equivalent range when the 115 V position is selected.

The ac output of the transformer secondary, nominally 19 V, is fed to the bridge rectifier (D1) mounted on the printed circuit board. The resultant dc voltage is smoothed by capacitor C1, which is fixed by clips in the channel immediately behind the printed circuit. Capacitor C2 and resistors R20 and R21 reduce power-line related interference effects. Light emitting diode D2 provides an indication that the unit is switched on.

## 7.3 Signal Paths

The two channels are identical; thus only one need be described. The circuit reference numbers of the second channel are in parentheses.

Audio input signals are routed from the input connector JF2 (JF4) to a tagstrip near the input transformer T2 (T4). Switch S6 connects a 620 ohm resistor across the input to provide a 600 ohm termination when required. Normally the input is bridging high impedance (10 kohm). The secondary of the transformer is routed to the printed circuit board. The high frequency resonance of the transformer is damped by resistor R1 (R3) mounted on the top surface of the printed circuit board. Trimpot RV1 (RV3), labelled IN A, attenuates the input line level to suit the requirements of the module; the trimpot is a screwdriver-adjust control which is accessible when the front cover plate is removed. The sensitivity of the unit is such that a minimum input of about 350 mV is required for Dolby Level.

The output level control RV2 (RV4), OUT A, is the NRM line amplifier gain control, enabling the output signal to be set at levels up to + 8 dB for Dolby Level. This control is accessible when the front cover plate is removed.



The unbalanced output of the NRM is routed to the output transformer T3 (T5) through capacitor C5 (C6), mounted under the transformer tagstrip, isolating the dc voltage component present at the module output. The transformer has a 1:2 step-up ratio, providing a maximum output signal in excess of + 21 cBm into 600 ohms. Resistor R5 and capacitor C3 (R6, C4) form a high frequency damping network, which damps the 500 kHz resonance of the transformer. This high resonant frequency is a consequence of the extremely low leakage reactance of the transformer, which is necessary to maintain a low output impedance (approx. 20 ohms) throughout the audio pass-band. The transformer secondary is connected to the output connector JM3 (JM5), and is free from any earth connection.

#### 7.4 Meter Circuit

The noise reduction module contains meter amplifiers which provide ac output signals related to the operating parameters of the noise reduction system (see Section 5); these in turn are related to the flux on the tape or deviation in FM transmission systems. In order to correlate the various voltage levels or FM deviations used in the audio chain, the concept of 'Dolby Level' is employed. Dolby Level signals are generated in the 330 series unit and can be used to calibrate the complete chain. Dolby Level corresponds to meter signals of 1.85 V from the module. The meter circuits in the 330 series interface are driven by these signals and display them on calibrated scales.

Referring to the 330 series interface circuit, each meter signal is rectified by the appropriate voltage doubler D10 and D11 acting with the meter amplifier output capacitor in the NRM. The resulting dc is fed to the meter via a non-linear network R14 and D12 which is used in some applications to linearize the meter and in others to protect the meter from overload. With an input of 1.85 V, the input attenuator (R10) is factory-adjusted to give half-scale deflection, corresponding to the Dolby Level mark. Under these conditions the voltage developed across the meter is less than 0.6 V, so that D12 does not conduct. As the input level is raised, this diode conducts, progressively shunting current from the meter. Full scale deflection corresponds to about 5 dB above the Dolby Level mark.

All the meter components are mounted on a printed circuit sub-assembly which is in turn fixed to the meter casing. The complete meter sub-assembly must be exchanged if meter replacement is ever required, since the meter calibration procedure involves the characteristics of the individual meter.

#### 7.5 Functions of 330 Series Unit

The 330 series units can be used either for the production of Dolby B-Type encoded pre-recorded tapes (Model 330) or for encoding FM broadcasts (Model 334). Linking the appropriate terminals on the interface printed circuit board (under top cover of unit) provides the Cat. No. 66 B-Type noise reduction module with function information (Tape Duplication or FM Broadcasting) which is used together with the mode information (encode or decode) to provide the necessary circuit configuration.

In the case of the Model 330 Tape Duplication Unit, link LK1 (Duplicator) is connected so that terminal B3 on the Cat. No. 66 module is grounded. The position of the duplicator link is marked on the upper surface of the board. In the Model 334 FM Broadcast Unit, link LK1 is in the 'Broadcast' position, which leaves terminal B3 on the Cat. No. 66 module unconnected. When used in North America, where the FM pre- and de-emphasis time-constant is 75 usec for non-Dolby broadcasts, link LK2 is in the '75 usec' position, which leaves terminal B2 on the Cat. No. 66 module unconnected. In the rest of the world the time-constant is 50 usec; link LK2 (in '50 usec' position) grounds terminal B2 in this case.

#### 7.6 Mode Switching

The mode (encode, decode) of the Cat. No. 66 B-Type noise reduction module is electronically controlled by transistor switches within the module. Both channels operate in the encode mode when a positive potential is applied via S5 to terminals B4 and B22 of the module (S5 is located behind the front panel access plate).

The noise reduction action may be controlled by the front panel push button switch S2. With S2 in the out position, and local operation selected (see subsection 7.8), a ground connection is applied to terminal A2 of the module, removing the noise reduction action (and, in the case of the Model 334, causing the time-constant to revert from 25 to 75 or 50 usec). Removing the ground restores the noise reduction action; the potential on terminal A2 rises to its normal value of 12 volts, causing the transistor pair Q3 and Q4 to switch on. Indicator lamp LP2, inside S2, is therefore illuminated.

#### 7.7 Dolby Tone Operation

Push button switch S3 controls the Dolby Tone oscillator within the Cat. No. 66 B-Type noise reduction module. Pushing S3 switches on transistor switch Q2, illuminating indicator lamp LP3 inside S3, also causing Q1 to switch on. A ground connection is therefore applied to terminal A3 of the noise reduction module, which starts the internal oscillator.

#### 7.8 Remote Operation

Operation of the Remote switch S4 transfers complete control of the NR in-out function to a remote location, such as the studio, and parallels the Dolby Tone operation to this remote location. With S4 depressed, grounding pin 5 of the rear-mounted socket JF6 turns off the noise reduction action, and grounding pin 2 turns on the Dolby Tone oscillator. The local Dolby Tone switch on the unit is still in circuit, but the local NR in-out is isolated. In local or remote operation the NR in-out indicator lamp LP2 shows the correct status of the unit.

## 7.5

The Dolby Tone indicator lamp LP3 is however illuminated whenever the Dolby Tone switch is pressed.

The total resistance in either remote operation line should be less than 1 kohm. A ground connection can be obtained from pin 1 of JF6; if possible, a remote ground should not be used.

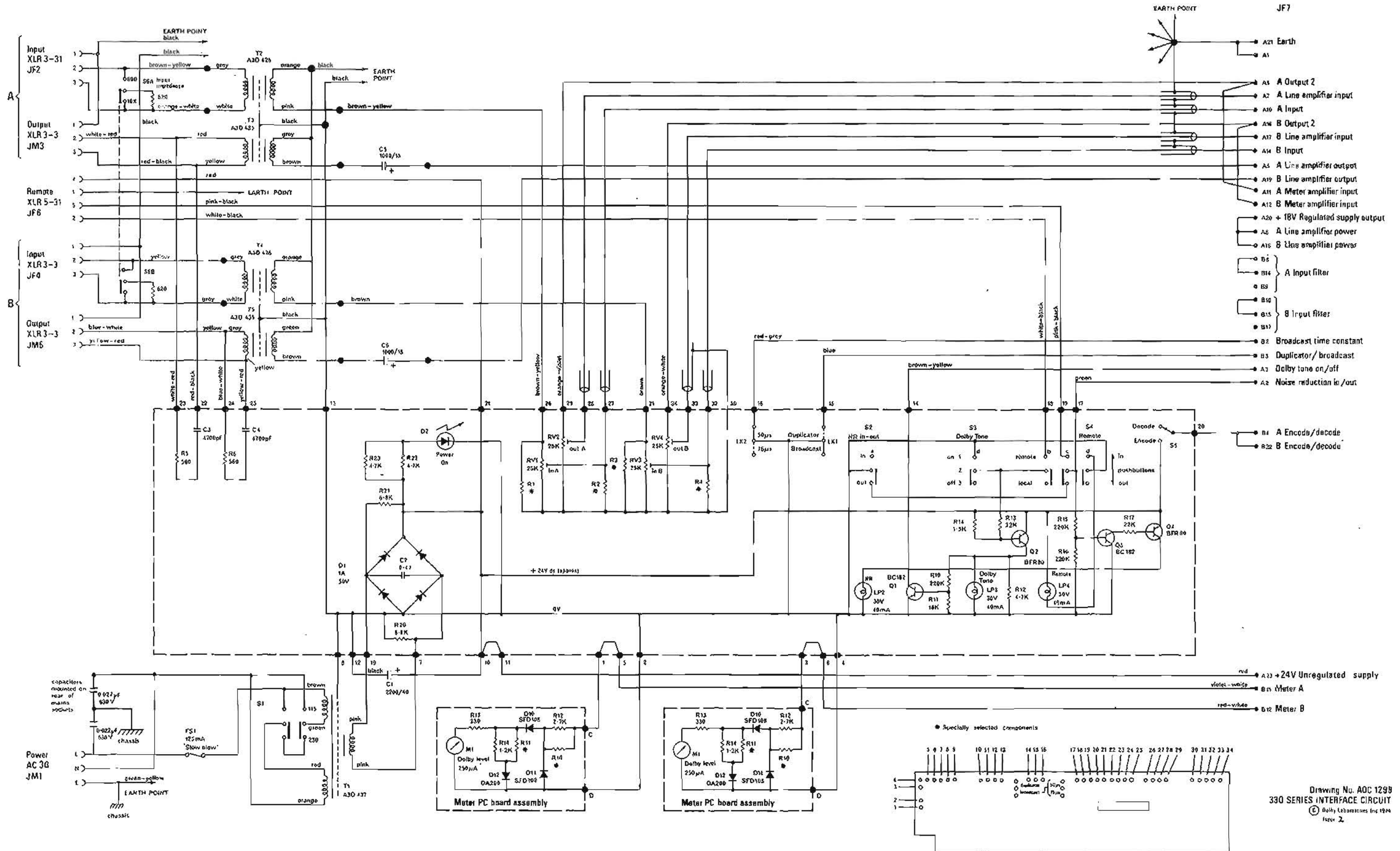

SECTION 8  
INTERFACE SERVICING

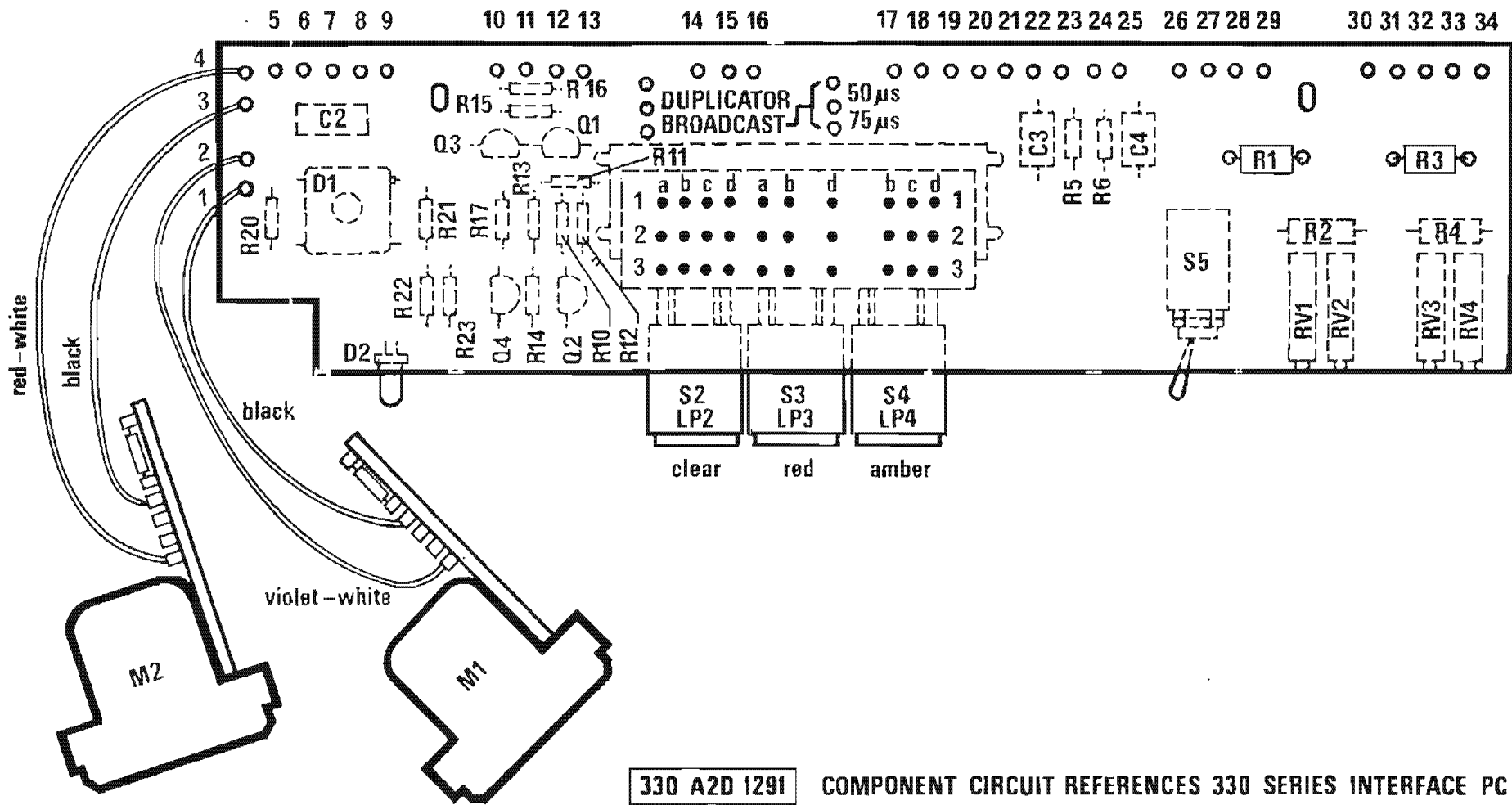

330 A2D 1291 COMPONENT CIRCUIT REFERENCES 330 SERIES INTERFACE PC

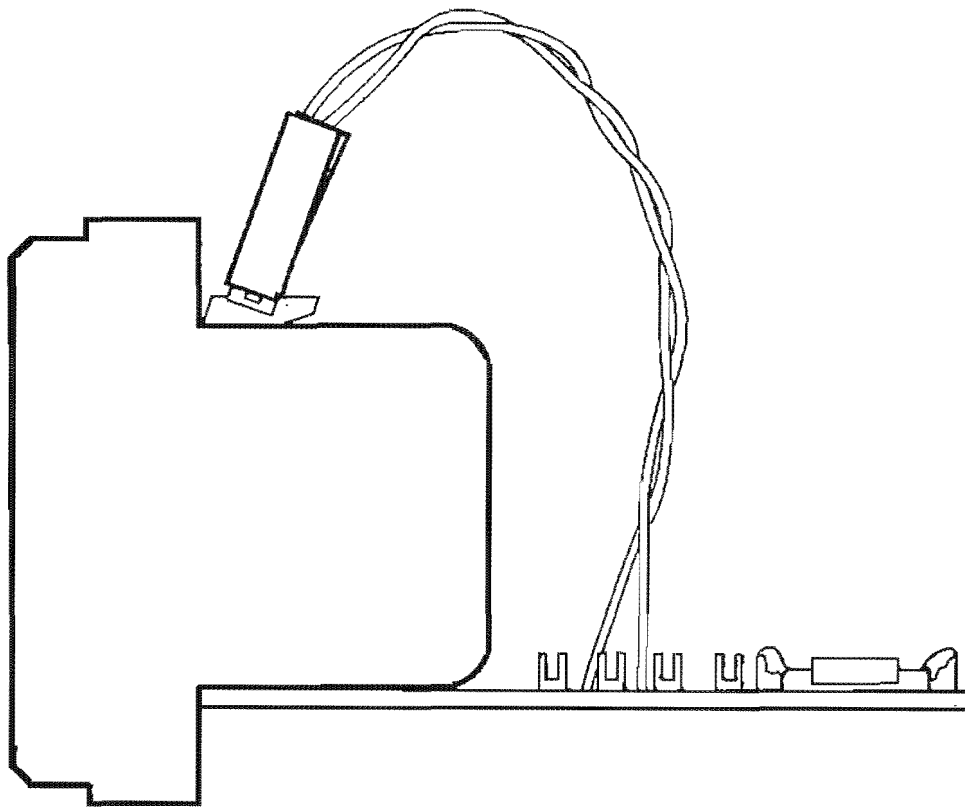
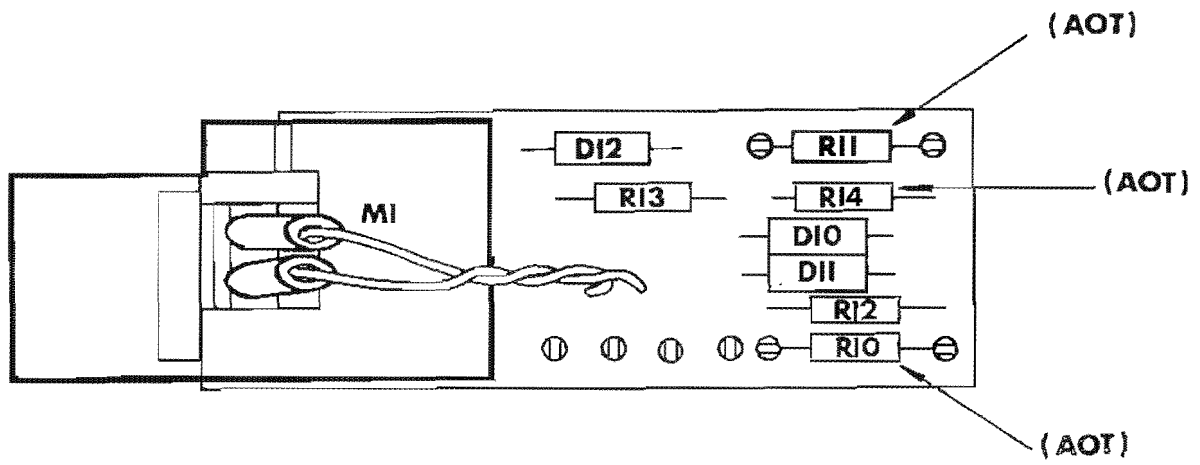

A2D 660/1

COMPONENT CIRCUIT REFERENCES — METER PC

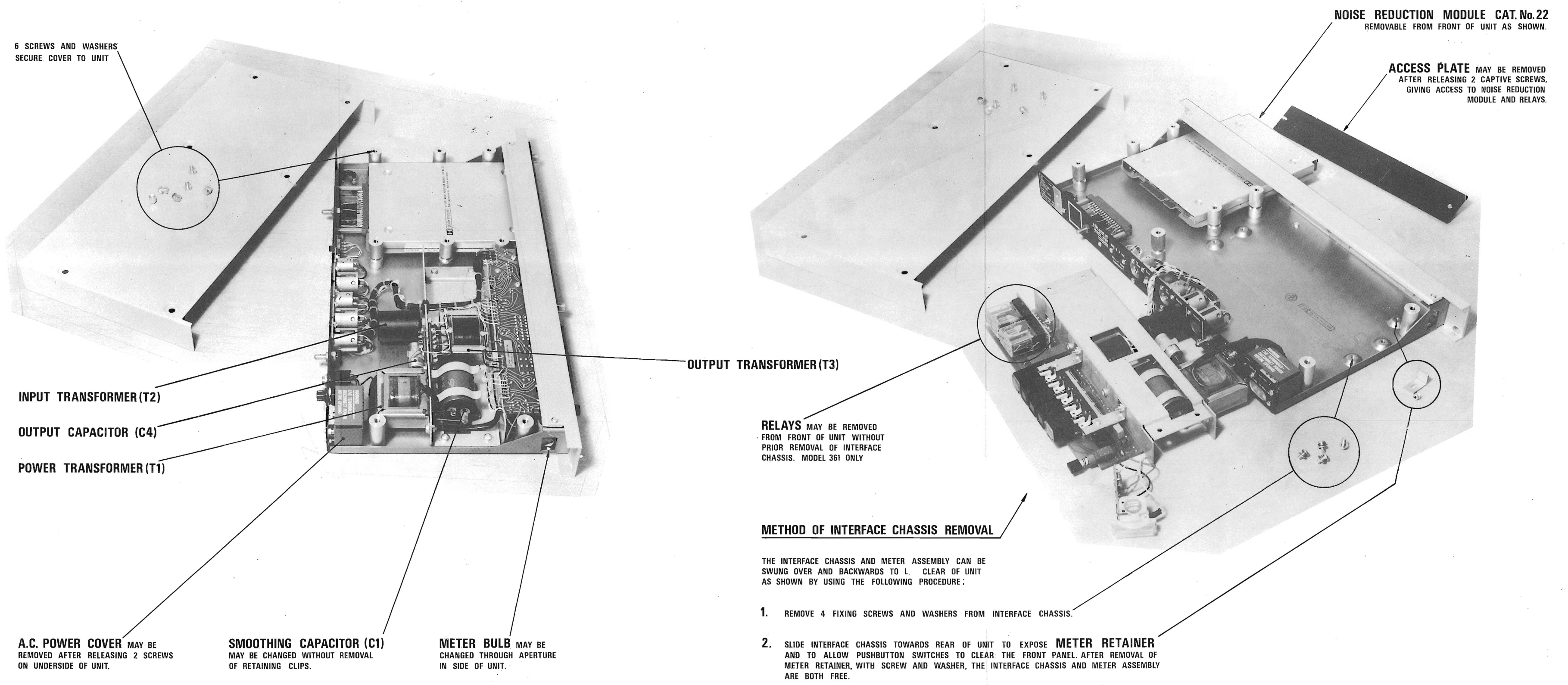

6 SCREWS AND WASHERS  
SECURE COVER TO UNIT

INPUT TRANSFORMER (T2)  
OUTPUT CAPACITOR (C4)  
POWER TRANSFORMER (T1)

A.C. POWER COVER MAY BE  
REMOVED AFTER RELEASING 2 SCREWS  
ON UNDERSIDE OF UNIT.

SMOOTHING CAPACITOR (C1)  
MAY BE CHANGED WITHOUT REMOVAL  
OF RETAINING CLIPS.

METER BULB MAY BE  
CHANGED THROUGH APERTURE  
IN SIDE OF UNIT.

OUTPUT TRANSFORMER (T3)

RELAYS MAY BE REMOVED  
FROM FRONT OF UNIT WITHOUT  
PRIOR REMOVAL OF INTERFACE  
CHASSIS. MODEL 361 ONLY

**METHOD OF INTERFACE CHASSIS REMOVAL**

THE INTERFACE CHASSIS AND METER ASSEMBLY CAN BE  
SWUNG OVER AND BACKWARDS TO CLEAR OF UNIT  
AS SHOWN BY USING THE FOLLOWING PROCEDURE:

1. REMOVE 4 FIXING SCREWS AND WASHERS FROM INTERFACE CHASSIS.
2. SLIDE INTERFACE CHASSIS TOWARDS REAR OF UNIT TO EXPOSE METER RETAINER AND TO ALLOW PUSHBUTTON SWITCHES TO CLEAR THE FRONT PANEL. AFTER REMOVAL OF METER RETAINER, WITH SCREW AND WASHER, THE INTERFACE CHASSIS AND METER ASSEMBLY ARE BOTH FREE.

**NOISE REDUCTION MODULE CAT.No.22**  
REMOVABLE FROM FRONT OF UNIT AS SHOWN.

**ACCESS PLATE** MAY BE REMOVED  
AFTER RELEASING 2 CAPTIVE SCREWS,  
GIVING ACCESS TO NOISE REDUCTION  
MODULE AND RELAYS.



SECTION 9

CAT. NO. 66 NOISE REDUCTION MODULE - CIRCUIT

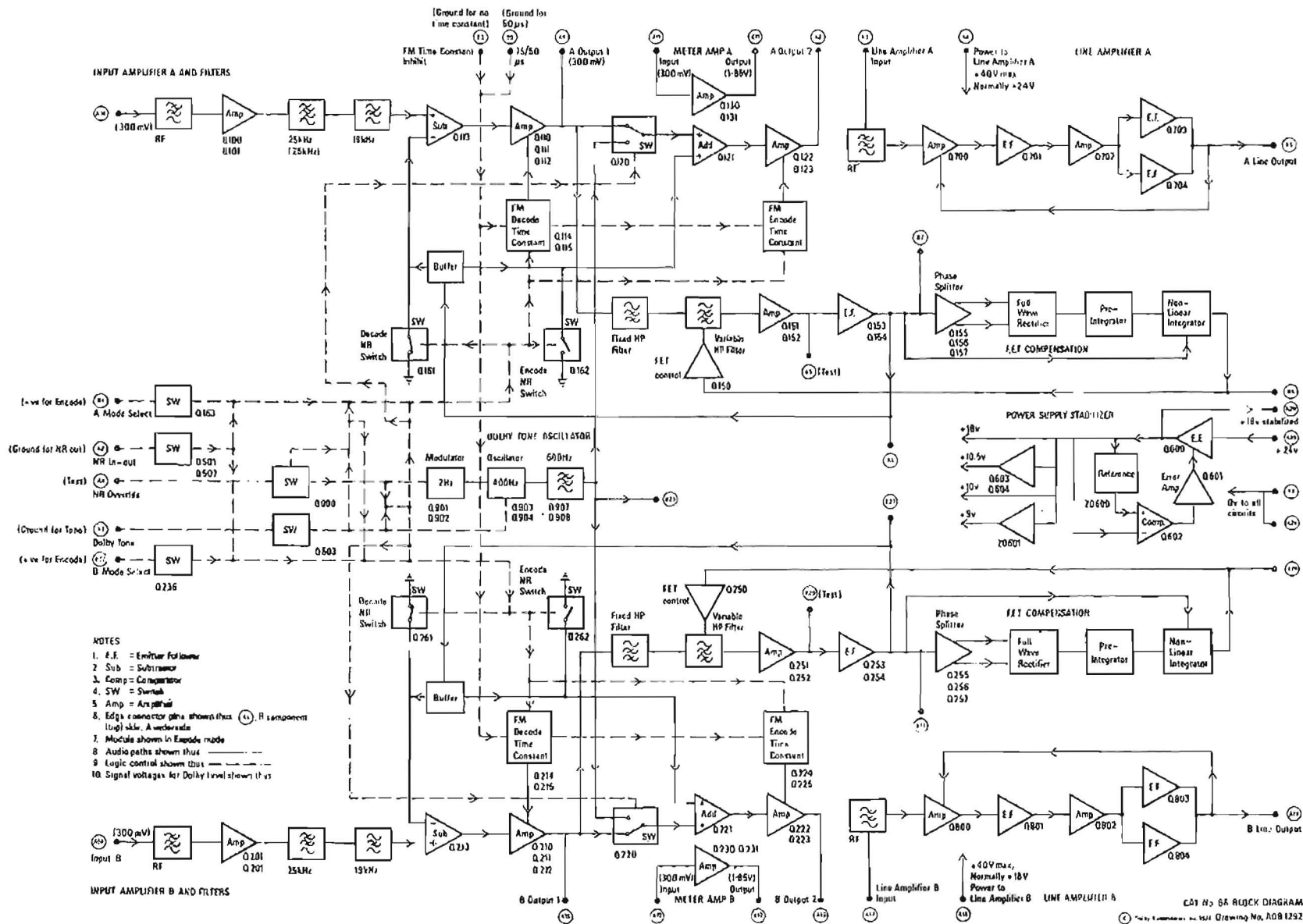

- NOTES
1. E.F. = Emitter Follower
  2. Sub = Substrainer
  3. Comp = Compensator
  4. SW = Switch
  5. Amp = Amplifier
  6. Edge connector pins shown thus ( ) if component (up) side, A underneath
  7. Module shown in Encode mode
  8. Audio paths shown thus ---
  9. Logic control shown thus ---
  10. Signal voltages for Dolby level shown ( )

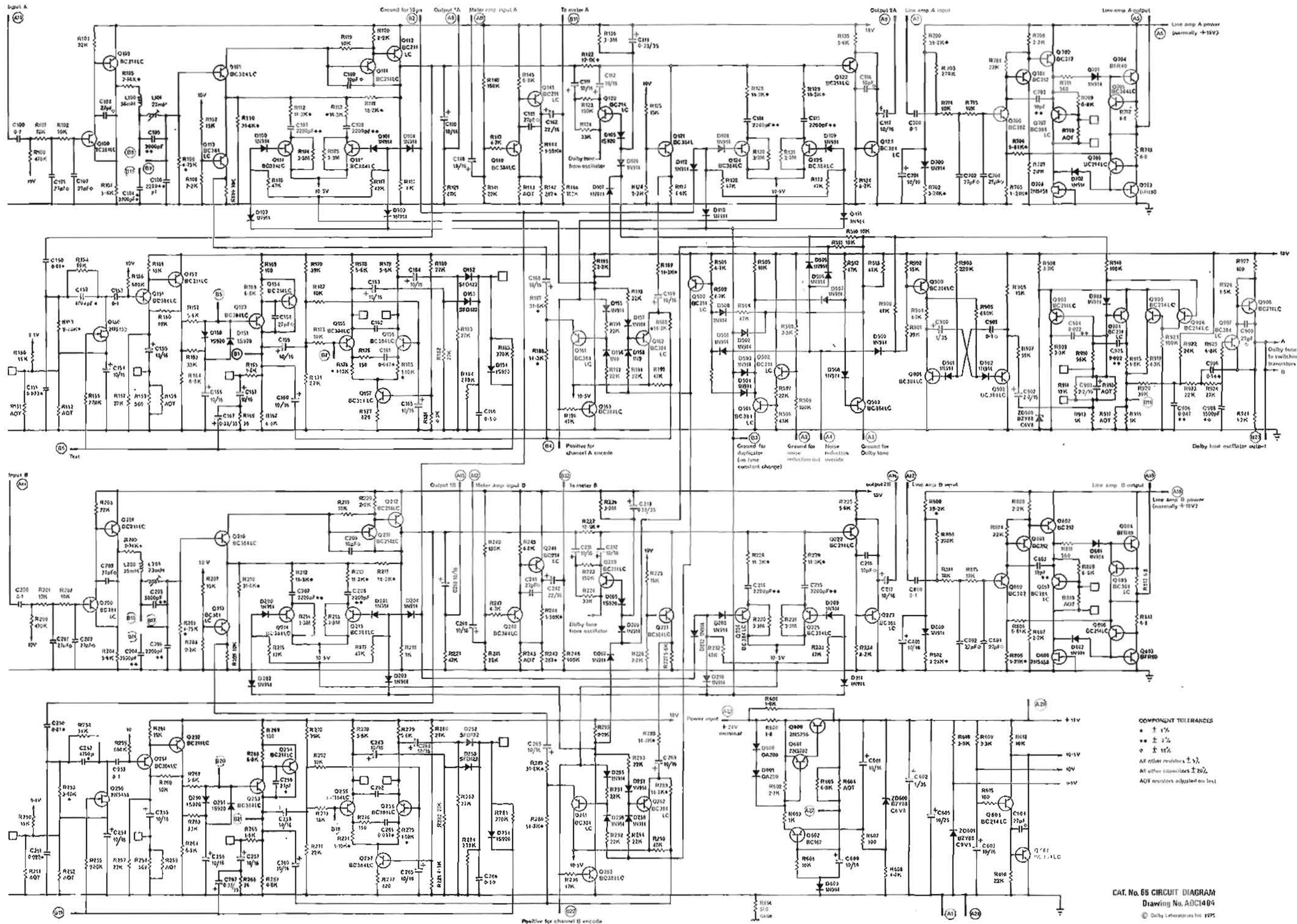

CAT. No. 66 CIRCUIT DIAGRAM  
 Drawing No. AOC1404  
 © Dolby Laboratories Inc. 1975