

**INSTRUCTION
BOOK**

**M5133
GATESWAY
CONSOLE**

**HARRIS
INTERTYPE
CORPORATION**

GATES

M-5133C GATESWAY CONSOLE

INDEX

	Page
1. Specifications	1
2. Introduction	2
3. Installation	2
(a) Ambient Temperatures	2
(b) Cable and Conduit Layout	3
(c) Grounding Circuits	3
(d) Balanced and Unbalanced Lines	3
(e) Circuit Impedances	4
(f) Power Wiring & Interconnection	4
(g) Wire Sizes	4
4. Operation	5
(a) Cue-intercom Selector	5
(b) Utility Keys	5
(c) Channel 4 Selector	5
(d) Turntable Selector Keys	5
(e) Net & Tape Input Keys	5
(f) Remote Line Input Keys	5
(g) High Pass Filter Switch	6
(h) VU Meter	6
(i) Monitor Input Selector & Level	6
(j) Channel 1 through 4	6
(k) Line Phone Jack	6
(l) Channel 5 through 8	6
(m) Master Gain Control	6
(n) Program Line Selector Key	7
(o) Emergency Monitor Operation	7
5. Principles and Theory of Operation	7
(a) Frequency Determining Components	7
(b) Cue-Intercom System	7
(c) Channel 4 Selector	8
(d) High Pass Filter	8
(e) Switch Detail Drawings	8
(f) Mixing System	8
(g) Preamplifier	8
(h) Program Amplifier	8
(i) VU Meter & Isolation Pad	8
(j) Monitor Booster Amplifier	8
(k) Input to Tape Recorders	8
(l) Power & Relay Deck	8
(m) Regulated Power Supply (Part of M5548F)	9
(n) Monitor Amplifier (Part of M5548F)	9
(o) Maximum & Minimum Voltages	9
6. Maintenance	9
(a) Tube Socket Voltages	10
(b) Other Components	10
7. Modification for Extra Facilities	10
(a) Utility Keys	10
(b) Additional Microphone Channel	11
(c) Additional Speaker Muting Relays	11
(d) Patch Panel Facilities	12
(e) Turntable Preamplifiers	12
8. Ordering Replacement Parts	12
9. Parts List	12
10. Drawings -	
A-10515 - High Pass Filter Curves	
A-10994 - Wiring Diagram - Mixing System Switch	
A-10995A - Wiring Diagram - Program Line Switch	
A-10996 - Wiring Diagram - Monitor Input Switch	
A-11023A - Relay Switching Detail	
B-65310 - Schematic - M5568 Monitor Booster Amplifier	
842 3539 001 - Wiring Diagram - Power & Relay Deck M5548F	

838 0023 001 - Schematic - Cue Intercom Amplifier

838 0009 004 - Schematic - M6142 Program Amplifier

842 3540 001 - Functional Diagram of M5133C Console

11. Instruction Book -
M5215A Printed Chassis Preamplifier
Replacing Components on Printed Chassis (Gates has
a printed sheet furnished on request, no charge)

SPECIFICATIONS

1. MICROPHONE TO REGULAR PROGRAM LINE OUT:
GAIN: 104 db, ± 2 db @ 1000 cycles.
RESPONSE: ± 1.5 db from 30 to 15,000 cycles.
DISTORTION: 1% or less, from 30 to 15,000 cycles
@ +8 dbm output.
NOISE: 60 to 65 db below +8 dbm output, with -60 dbm
input (Microphone Control - Position 12, Master
adjusted).
CROSSTALK: Below microphone channel noise level
with normal inputs and control positions.
2. REMOTE, TAPE, NET AND TURNTABLE INPUTS
TO REGULAR PROGRAM LINE OUT:
GAIN: 61 db, ± 2 db @ 1000 cycles.
RESPONSE: ± 1.5 db from 30 to 15,000 cycles.
DISTORTION: 1% or less, from 30 to 15,000 cycles @
+8 dbm output.
1.5% or less, from 30 to 15,000 cycles
@ +18 dbm output.
NOISE: 70 to 75 db below +8 dbm output, with -10
dbm input (Channel Control - Position 8,
Master adjusted).
CROSSTALK: 70 db or lower between channels with
normal inputs, control positions and
operating levels (audition bus level
same as program bus level).
3. MICROPHONE TO MONITOR EMERGENCY LINE OUT:
GAIN: 104 db, or more @ 1,000 cycles.
RESPONSE: ± 2 db from 30 to 15,000 cycles.
DISTORTION: 1% or less, from 50 to 15,000 cycles
@ +8 dbm output.
NOISE: 55 to 60 db below +8 dbm output, with -60 dbm
input (Microphone Control - Position 12, Moni-
tor Gain adjusted).
CROSSTALK: Below microphone channel noise level
with normal inputs and control positions.
4. REMOTE, TAPE, NET AND TURNTABLE INPUTS
TO MONITOR EMERGENCY LINE OUT:
GAIN: 85 db or more @ 1,000 cycles.
RESPONSE: ± 2 db from 30 to 15,000 cycles.
DISTORTION: 1% or less from 50 to 15,000 cycles
@ +8 dbm output.
NOISE: 55 to 60 db below +8 dbm output, with 10 dbm
input (Channel Control - Position 8, Monitor
Gain adjusted).
CROSSTALK: 65 db or lower between channels with
normal inputs, control positions and
operating levels (audition bus level
same as program bus level).
5. MONITORING AMPLIFIER:
GAIN: Adjust as instructed in Item 3 above. Maximum
gain far exceeds this figure but can not be
utilized in normal programming.
RESPONSE: ± 2 db from 30 to 15,000 cycles.
DISTORTION: 1% or less from 50 to 15,000 cycles
@ +40 dbm (10 watts) output.

NOISE: 60 db below +40 dbm output, with -10 dbm input to remote line (Channel Control - Position 8, Monitor Gain adjusted).

6. CUE - INTERCOM AMPLIFIER

Cue-Intercom Amplifier will be aural check only.

7. HI - PASS FILTER

Check points on hi-pass filter.

30 cycles, 100 cycles, 1 KC*, 5 KC, 10 KC, and 15 KC must be ± 3 db with graph in position 1, 2 and 3.

*1 KC reference point.

Positions 1, 2 and 3 must be within 1 db of 0 position at 1 KC.

INTRODUCTION

The M-5133C Gatesway Console is designed to use for programming in AM, FM and TV installations that demand the very finest quality in speech input systems. The extreme flexibility allows its use in nearly any type of operation, yet the functional styling and design make the operation very simple. The functional diagram, D-22140, and the following sections will enable the operator and engineer to find all of the available facilities and show how to utilize them.

The main program facilities consist of eight input channels with low impedance, step type attenuators mixing into a single line output channel. Full monitoring facilities are provided, including a house P.A. monitoring amplifier for feeding multiple speakers and a self-contained cue-intercom system. The house P.A. monitoring system may be fed from the program line, audition bus or an external source, such as an off-the-air feed. The cue-intercom system has eleven inputs which include all of the major circuits in the console. Multiple input selection to the proper channels greatly expand the operation of the console. Convenient emergency operation of the monitoring amplifier in place of the program amplifier adds a large safety factor to the operation of the console.

Breaking and jumpering of all major circuits allows full use of normalling jack fields, with all connections brought out to the main terminal board for ease of installation and future circuit checking. Three standard speaker muting and warning light relays, with provisions for two additional relays, insure foolproof operation. Associated positioning of related switches and controls, along with the best sequence of controls, makes learning the operation fast and minimizes daily mistakes.

Compensation of all levels, by the use of fixed pads, throughout the console makes operation very simple (since the level seldom needs to be readjusted) when switching from one circuit to another. Complete interlocking of the cue-intercom system, along with this compensation, allows the operator to use it at any time; yet it cannot interfere with programming.

Each component was carefully chosen to more than adequately fill its particular job. Among the newest components employed are the printed chassis of the preamplifiers, the program amplifier, monitor amplifier and regulator (on the power supply). Some printed pad boards are used also. All of the circuits and components have been proven in service, and found very dependable.

Many extra features may be obtained with slight modification of existing facilities or by installing extra ones. Provisions have been made for these modifications and a separate section is devoted to a full explanation of their use and method of installation. Operation, if changed from normal, is also well covered.

This introduction has touched on some of the more important points of the Console to give general information without excessive details. Those concerned with the daily operation should carefully study the section labeled "Operation". The installation crew should study their section before actually starting the work. In fact, each section is broken down to cover different phases so that unnecessary confusion may be eliminated and the answer to any particular question may be easily found. The engineering staff is urged to become acquainted with all sections so that they can advise other groups in the best performance, as well as being able to keep the console in top operating condition.

INSTALLATION

The Console will arrive in several boxes or cartons. The following main items will be enclosed.

- 1 - Console proper, with tubes installed.
- 2 - M-5548F Power and Relay Deck with tubes installed.
- 3 - A-10360-1, DC53 Knob Decal Kit
- 4 - IB 888 0932 001 Instruction Book for Gatesway Console.

The cabinet of the Console is 39" long, 15" deep and 7 1/2" high. The cabinet lid swings up and must have 12 1/2" clearance from the desk top. The lid also needs 1/2" clearance back of the cabinet in the raised position. The panel swings down but the normal foot or more allowed in front of the cabinet provides plenty of clearance for this. Stops are incorporated for both panel and lid to prevent over-travel but they should be opened gently to prevent springing.

The base of the cabinet has large dimples pressed into it to raise it from the desk surface. Each of these dimples have holes in them to permit the use of wood or sheet metal screws in fastening the cabinet to the desk. A row of cable access holes along the rear of the cabinet base and another row in front of the main terminal board provides the choice of cable location. The desk top should be drilled to permit the external cables to come into the cabinet at the proper location. Before this drilling is done, however, cable routing and isolation must be planned.

AMBIENT TEMPERATURES

The Power and Relay Deck containing the relays, power supply and monitoring amplifier is the standard 7" by 19" size for rack mounting. If desired, it may be mounted in a small wall box or in the base of the desk. Ample ventilation must be provided since the units generate considerable heat. If the ambient temperature of the rack is below 50° C. or 122° F., the rack does not need forced ventilation.

If the Power Deck is placed immediately below a unit that blocks the natural rising of the warm air, or if a unit generating a lot of heat is placed closely below it,

the rack should be exhausted with a fan or some method provided to increase the air flow through it.

Under these conditions, forced ventilation should be used even if the ambient rack temperature is under 50° C. Of course, if the ambient rack temperature is above 50° C., forced ventilation should be used. These limitations also apply to the Power and Relay Deck when wall mounted or desk mounted.

CABLE AND CONDUIT LAYOUT

Cable and conduit layout is of utmost importance in the studio installation. One well planned and executed will assure optimum results. One hastily installed, without thought, invariably results in continuous trouble until rebuilt. First, the matter of signal levels; the low level cable may include circuits from -60 dbm to -20 dbm. The medium level may include levels from -20 dbm to +14 dbm. The high level cable may include levels from +14 dbm to +40 dbm. The 115 volt a.c. lines should be run in separate cables. Whenever possible, do not run any of the four cables listed in a conduit along with cables of different level classification. If two or more cables must be run in a common conduit, never exceed a difference of 40 db in level between the lowest level and the highest level in either cable. Use high quality shielded twisted pair for all audio wiring, such as Gates catalog number 1261. For all microphone wiring and long medium level cable and conduit runs the use of rubber, plastic or cloth covered shielded pairs eliminates multiple ground loops and the resultant noise problems. Gates catalog number 8440 Microphone Cable is recommended.

In parallel cable runs of different levels, the most important aid is physical isolation. Up to six inch spacing is preferred. If there is not room for this isolation, do not lace all of the wires in the same cables. Keep the cables laced separately for the different level classifications even if two or more must lay together. This will give much better isolation than when formed into one cable. The deviations from the preferred methods must not be taken lightly. Use them only as a last resort, not just for convenience.

The cable access holes in the cabinet base allows cables of different levels to be separated from the point where they join the main terminal board in the console. Microphone cables connecting on the left side, medium levels in the center, and right hand side. Actually, the only pairs that need to be classified as high level in the console are the studio intercom connections. They connect to TB7-3 & 4, 11 & 12, 5 & 6, 13 & 14. They should not run in regular program cables or conduits since they vary in level from -50 dbm to +20 dbm and are auxiliary circuits only. None of the other circuits of the console proper exceed +14 dbm since the two outputs of the monitoring amplifier are padded down before entering the interconnecting cable. Of course, the speaker outputs from the power deck are high level and should not run with low level cables.

Conduit generally affords enough shielding so that different levels in separate conduit presents no isolation problem even without spacing them apart. Microphone level conduit and speaker level conduit can probably run along together with no crosstalk. If practical, it is advisable to maintain physical separation and add to

the safety of the installation. Power circuit, especially those with high current, should not be in close proximity with program carrying conduit; electro magnetic shielding is poor in most conduit.

GROUNDING CIRCUITS

Circuit grounding, like cable layout and most systems work methods is unpredictable to a certain extent. Therefore, no hard and fast rules apply 100% of the time. In this section it is attempted to cover the things to avoid and to present generally accepted practices that always give good results, or allow good results to be obtained with minor modification. Entirely different approaches have been used, some with good results, but unless you are an expert on the subject, most are risky.

The console grounding system is based on the one point ground: Different circuit grounds are insulated from the chassis and other grounds except at one point, where they all join together and go to earth ground. This system prevents multiple ground loops with the resulting hum pickup from circulating currents and R.F. pickup and regeneration.

External circuits connecting into the console should not destroy this system. Microphone circuits are not grounded in the console, neither should they be grounded externally except after noise checks have been made, then they may be grounded if better results are obtained. Turntable inputs are grounded in the console and should be ungrounded externally. Net, tape and remote inputs are ungrounded in the console and may be grounded externally. The program line output is not grounded in the console but may be center-tap grounded at the telephone line if desirable.

Thus, a safe rule to follow is: do not ground either side of external circuit. Generally, the shields of the cables should ground at the console only. They may be connected to the ground terminals marked "G", in the center of each group of terminals on the main terminal board. There may be exceptions to this rule, especially on microphone input circuits, so the shield grounds should be wired in such a manner that they can be lifted in the console and grounded at the other end. Again, this is part of the test procedure and used to obtain lowest noise.

If patch panel facilities are used, special considerations of circuit grounding are necessary. Look in the section marked "Modification For Extra Facilities" for instructions.

BALANCED AND UNBALANCED LINES

If a circuit is ungrounded, it is considered balanced to ground. If one side is grounded, of course it is unbalanced. If the circuit is center-tap grounded with pad or coil, it is balanced to ground. Refer to the third paragraph under "Grounding Circuits" for determining proper classification. Twisted shielded pairs should be used for all circuits, whether they are balanced or unbalanced. Cancellation of noise and cross-talk pickup is approximately the same for either when the one point ground system is used.

If it is necessary to connect a balanced line to an unbalanced line, or the opposite, an isolation transformer should be used between them. The transformer must

have good balance, an electrostatic shield and magnetic shielding sufficient to reduce the hum pickup at least 65 db below the signal level. Impedance taps on primary and secondary are important to properly match both circuits. The Gates Radio general catalog lists these transformers. Balanced lines require balanced pads and attenuators, unbalanced lines require unbalanced ones. Mixing them generally results in poor noise, frequency response or other poor operation.

CIRCUIT IMPEDANCES

The microphone inputs are factory connected for 150/250 ohms. With this impedance, connect to terminals 1 & 2. If 30/50 ohm microphones are used: Remove the jumper between 5 & 6, jumper 1 & 5, jumper 2 & 6 and connect to terminals 1 & 2. These are balanced inputs.

Turntable inputs are 150/250 ohms and cannot be changed in the console. Other impedances would have to be obtained with the use of a matching pad or isolation transformer. If a matching pad is used, it should be unbalanced and its common side connected to the common or grounded side of the inputs, the even numbers (2, 4, 6, 8, etc.) are the grounded side. It would be well to check the incoming circuit for grounds with an ohmmeter prior to connecting them. The external ground, if any, should be removed.

Net and tape inputs are factory connected 600 ohms. The impedance may be changed by changing taps on T2, the matching transformer for this channel. Terminals 1 & 3 are for 500/600 ohms, 1 & 2 for 150/250 ohms and 2 & 3 for 30/50 ohms. This is seldom desired since most tape recorders and the network line terminate in 600 ohms. The lines are balanced.

The remote inputs are factory connected 600 ohms. The matching transformer for this channel, T3 may also be changed to lower impedances. Terminals 1 & 3 are for 500/600 ohms, 1 & 2 for 150/250 ohms and 2 & 3 for 30/50 ohms. Channel 8 can be used for net and tape inputs as well as remote inputs, so if the impedance is changed it must accommodate all of them. The remote inputs are balanced.

POWER WIRING AND INTERCONNECTION

A five ampere circuit, 117 volts 50/60 cycles, is sufficient to operate the console power supply and relay supply. This connects to TB101-1 & 2 on the power deck. This circuit should be separate for the console from other units so that a possible short will not shut down the whole system. Proper A.C. wiring in the studio demands many branch circuits and will pay off in minimizing down time.

Drawing 842 3539 001, the wiring diagram of the power deck, shows all of the interconnection data between it and the console cabinet. The main functional diagram 842 3540 001 essentially duplicates this but does not separate the pairs of some circuits. Thus, it does not show how to connect the common wires. Referring to 842 3539 001: The console filaments connect TB13-1 to TB101-12 and TB13-2 to TB101-11. B₊ connect TB13-3 to TB101-9, B₋ connect TB13-4 to TB101-10. Relay Coil 1 connect TB13-5 to TB102-1A and TB13-6 to TB102-17A. Relay 2 connect TB13-7 to TB102-13A. Relay 3 connect TB13-8 to TB102-10A.

As explained in paragraph three under "Cable and Conduit Layout" keep the studio intercom circuits separate from regular programming circuits. Connect TS7-3 to TB102-14A; TS7-4 to TB102-14B. Connect Studio A intercom speaker to TB102-14B and TB102-13B. The common side, TB102-14B, must not be grounded. For Studio B intercom: Connect TB7-11 to TB102-11A, and TB 7-12 to TB102-11B. The speaker goes to TB-102-11B and 10B. The console intercom speaker is muted along with the control room monitor speaker by relay 3. Connect TB9-7 to TB102-8A and TB9-8 to TB102-7B.

Should control room speaker muting be unnecessary, the third relay can be used to mute a speaker in a third studio (Studio C). The studio C intercom will be connected as follows: TB7-5 to TB102-8A, and TB7-6 to TB102-8B. The studio intercom speaker goes to TB 102-8B and 7B. A jumper should be connected between TB9-7 and TB9-8 if you do not want the console intercom to mute.

For the house monitoring speakers: Connect Studio A (speaker 1) to both terminals of TB102-15, Studio B (speaker 2) to TB102-12 and Control or, Studio C (speaker 3) to TB102-9. The speakers have 45/50 to 6/8 ohm speaker matching transformers. Use Gates A-30601 transformers or the equivalent. The relay deck has 47 ohm back loading resistors across the speaker lines when a speaker is muted.

The warning lights are supplied with 115 volts a.c. out of the Relay Deck. One side is switched with the muting relay, one side is common. It is recommended that lights of over 60 watts not be used, as this would cause excessive arcs in the relay contacts. Studio A warning light 1, connect one side only to TB101-3; Studio B warning light 2, connect to TB101-4; Studio C, or control warning light 3, connect to TB101-5. Connect the other side of all three lights to TB101-8. The common side must not be grounded.

NOTE: The monitoring speakers, intercom speakers and warning lights are set up to operate with certain microphone channels. Drawing A-11023-A shows this coding. Channels 1 & 2 operate relay 1, and these microphones should be placed in Studio A as referred to above. Channels 3 & 4B operate relay 2 for Studio B. Channel 4A operates relay 3 for Studio C. To change this standard coding, change the jumpers on Tie Point 1. This is located on the inside rear of the cabinet. Drawing A-11023-A explains the connection method presently used and modifications may be worked out.

The only interconnections left are the monitor input and the program cue output. For the input, connect TB6-9 & 10 to TB102-20. For program cue output, connect TB12-7 and 8 to TB102-18. Since there is approximately 40 db difference in level, these lines may be in a common cable; provided they are run in shielded twisted pairs. The same signal is applied to both pairs so there is no chance for cross-talk. There is not enough difference in level for oscillation.

WIRE SIZES

The only circuit that demands a minimum wire size in interconnection is the filament pair. #16 AWG is recommended for this connection. Do not worry about some voltage drop in this circuit, the source voltage is high

enough to permit this. #16 AWG is also recommended for the 115 volt a.c. input line to the panel and shelf assembly. All other wiring may be as small as #24 AWG with no bad effects. Adequate insulation must be provided for all wiring, 600 volt insulation would suffice in all cases.

OPERATION

The associated panel controls and switching plus the functional sequence of these parts, make operation of the Gateway Console extremely simple. Although a great number of switches are used, very few of them must be operated for any particular function and switching errors will be rare.

CUE-INTERCOM SELECTOR

Starting at the top and the left of the panel: The cue-intercom selector switch has eleven positions. Each of the eleven positions may be monitored and eight of them can receive talk-back. Only the program line, turntable cue bus and the audition bus are interlocked so that you can not talk out on them under any condition. The four remote lines may be used for two-way conversation when they are switched to the center talk-back position. When they are switched to the mix or program cue position, it is impossible to talk out on them or listen to them in the normal manner.

An over-ride function for the remote lines is wired in the console. When the remote switch is in the talk-back position, an incoming signal can be heard on the cue-intercom speaker regardless of the position of the eleven position selector switch. Thus, the remote operator can page the console operator without this selector switch being switched to his remote line. The levels are adjusted so that the remote signal will come in with sufficient volume to over-ride any other signal on the cue-intercom system. To talk back to the remote operator, the selector switch must be turned to his remote line.

The cue-intercom gain control and press-to-talk switch are located with the speaker directly below the VU meter in the center of the panel. The gain control will normally be placed half open and may be increased for low level signals if required. If the incoming signals are higher than normal they will not blast the operator. For talk-back, simply press the talk switch and speak towards the speaker with a normal voice. The system is quite sensitive and does not require shouting or placing your mouth near the speaker.

The intercom speaker on the console is set up to mute when the control room microphone (4A) is live. This muting does not disable the cue phone jack, so it is still possible to cue a record, by monitoring the cue circuit with headphones. This jack is labeled "Cue". The intercom speaker is interlocked with the headphone jack so that this speaker is muted whenever a phone plug is inserted in "Cue" jack.

If a microphone is not used in the control room, and relay 3 is used to mute the speaker in a third studio, the console intercom muting should be connected to mute the intercom in the studio. Jumper TB9-7 and TB9-8 to complete the console intercom speaker circuit.

The studio intercom speakers are muted with the regular speaker muting relays so that it is impossible to talk

back to a studio when there is a live microphone in it. These relays operate when the microphone channel is switched to either program bus or the audition bus. This interlocking feature makes it impossible to disturb the program and the console operator may use the intercom system without concern.

UTILITY KEYS

The five utility keys are located next to the cue-intercom selector switch. They are not wired at the factory and are for the customer's convenience for his special circuits. Their possibilities and limitations will be listed in the section labeled "Modification for Extra Facilities" and their use will be determined and explained by the station engineer.

CHANNEL 4 SELECTOR

This key is located to the left of the VU meter. It switches microphone 4B into channel 4 in the center position and 4A into channel 4 in the lower position. The speaker muting relays will switch along with the microphones to prevent a live speaker and microphone in the same location. It is assumed that 4A will be the control room microphone.

TURNTABLE SELECTOR KEYS

These two keys are located to the right of the VU meter. In the center position, TT-1 is switched into channel 5 with the first key and TT-2 is switched into channel 6 with the second key. TT-3 may be switched into either channel 5 or 6 by switching up and TT-4 may be switched into either channel by throwing the switches down. By this switching arrangement it is not necessary to dump any of the four turntables in by switching, they may be switched to the unused channel and faded in properly. It is necessary to plan ahead so that TT-1 and TT-2 do not have to follow TT-3 or TT-4 on the same switch, unless a break with another channel will allow the proper fading.

NET AND TAPE INPUT KEYS

The net key is located to the right of the turntable keys, the four tape keys are located to the right of the net key. If no network facilities are used the net key may also be used for a tape input or any other medium level input. All five of these keys switch into channel 7 in the upper position, into channel 8 in the lower position. This allows one tape input to follow another without dumping them in. They may be faded in properly as explained under "Turntable Selector Keys". Since the remote lines also feed into channel 8, it is necessary to plan ahead so that it will not be necessary to switch succeeding programs in on the same channel.

The center position of these five switches terminate the inputs into 600 ohm load resistors. These switches are not designed to permit the control of tape machines. External remote control facilities are available for most tape recorders.

REMOTE LINE INPUT KEYS

The four remote keys are located to the right of the tape keys. In the upper position they receive program cue signal from the monitoring amplifier, the level is ad-

justed to approximately ± 8 VU. This signal is fed back to the remote operator to allow him to start his program at the proper time. The lower position is the mix position and connects the remote program into the program bus through channel 8. The center position of the switches have a terminating load for the remote line and allows over-ride and talk-back functions. These were explained at the beginning of the "Operation" chapter under "Cue-intercom Selector". The remote lines are not tied together when any or all of the remote keys are in the talk-back position, there is approximately 80 db of isolation between them even with the over-ride tie-in on all lines.

A typical sequence of operation for a remote line will be: When the operator arrives at the remote point, he will call in to the console operator and will be heard on the cue-intercom system. The call will come in via the over-ride regardless of the position of the cue-intercom selector. The console operator will switch the selector to the proper remote line position and acknowledge the call and issue any necessary instructions. Then the console operator will switch the remote key to the program cue position. It will stay in this position until the remote is to go on the air. Then the console operator will throw the remote key to mix and bring it in on channel 8. Of course, any desired sequence may be used, the one described shows the facilities available for this operation.

HIGH PASS FILTER SWITCH

This switch is on the upper right of the panel. It has four positions: 0, 1, 2 and 3. The 0 position is flat and the filter is disabled. Position 1 is a moderate low frequency roll-off, 2 is a medium and 3 is a severe low frequency roll-off. This switch is a shorting type and can be switched during programming without clicks or change of level.

The switch may be used to reduce the hum on any circuit. It may be used to reduce set moving noise or excessive low frequency noise or signal of any type. It should not be used indiscriminately, but is a great aid when abnormal conditions are encountered.

VU METER

The only function missed along the top of the panel was the VU meter. It is calibrated to feed ± 8 VU into a 600 ohm line when the meter reads 0 VU or 100%. The station engineer should instruct the operator concerning the proper level desired on the meter. Normally ± 8 VU (the equivalent of 0 db, 6 MW across 500 ohms, the telephone company reference level) is used to feed a telephone line.

MONITOR INPUT SELECTOR AND LEVEL

The monitor input selector key is located at the lower left of the panel, directly above the monitor gain control. Throwing this key to position A connects the monitor input to the audition bus. Position P connects it to the output of the program amplifier. In the center position, the monitor input is connected to an external input such as the air monitor. This key and the gain control can be converted into a microphone channel, for this operation refer to "Modification for Extra Facilities".

The monitor gain control is a 10K ohm control and is located between the monitor booster and the monitor amplifier. It normally is placed about two thirds open. When calibrated this way, emergency operation is accomplished with little or no control changing from normal operation.

CHANNEL 1 THROUGH 4

The four microphone channels are located to the right of the monitor input selector and gain control. The channel keys direct the output of the channels to the audition bus in position A, to the program bus in position P and a terminating load in the center position. Throwing the keys either to A or P operate the speaker muting relays in the appropriate studios to prevent accoustical feedback. Very rapid switching may connect the microphone before the speaker is cut off because of the mechanical inertia of the muting relays. Experience will show the maximum acceptable switching speed. Both the audition and program mixing busses are compensated so that any number of channels may be mixed without interaction between controls.

The controls are step type and are calibrated in 2 db steps, tapered to infinity. They are normally adjusted to position 12.

LINE PHONE JACK

This phone jack is located to the right of the cue phone jack described under "Cue-intercom Selector". It is bridged across the program line. High impedance phones must be used since the bridging resistors will attenuate most of the signal with low impedance phones.

CHANNEL 5 THROUGH 8

All four of these channels have input switches to allow multiple circuit selection as previously described. Channel 5 connects to TT-1, TT-3 and TT-4. Channel 6 connects to TT-2, TT-3 and TT-4. Channel 7 connects to NET; Tape 1, 2, 3 and 4.

The channel keys direct the output of the channels to the audition bus and the program bus in the same manner as the microphone channels.

The channel attenuators are the same as the microphone channel controls except for a cue position. This is one step counterclockwise from the OFF or infinite position. When rotated to the cue position, the input signal to the channel is connected to the TT cue bus. It may be monitored via the cue-intercom system by selecting the TT cue position. This allows a cue or preview of the signal before fading it into the program channel.

MASTER GAIN CONTROL

This is located on the lower right of the panel. It is a tandem connected high impedance interstage control; electrically located between the first and second, and second and third stage of the program amplifier. It does a good job of keeping the signal to noise ratio acceptable. However, the program amplifier input can be overloaded so a word on all control settings is necessary.

With a normal dynamic microphone connected into a microphone channel, adjust the channel control to position

12. Switch the channel to the program bus and throw the switch above the master gain control to "REG". With a normal signal into the microphone, adjust the master gain until the peaks read 0 VU or 100% on the VU meter. Record the position of the master gain control and keep it adjusted near this position with any input channel connected into the program bus. Adjust the differences in level between channels with the channel controls.

If any of the channels must be adjusted below position 8 with normal input levels, ask the station engineer to pad the input to allow setting the level control above position 8. Best operation would be achieved when all of the input signals are attenuated (where required) so that all channel controls may be set to the same position. These pads may be purchased from the Gates Radio Company or constructed by the engineer. When ordering, please specify loss and input and output impedances.

PROGRAM LINE SELECTOR KEY

This is located directly above the master gain control. It is used to direct the program amplifier into telephone line in the "Regular" position. It directs the monitor amplifier into the line in the "Emergency" position. In the center position, it terminates and loads the line and both signal sources. The operation of this key is covered in the following section.

EMERGENCY MONITOR OPERATION

Normally the telephone line is fed from the program amplifier and the monitor amplifier is bridged across the output of the program amplifier to feed the house monitoring speakers. If the program amplifier fails, the monitoring amplifier can take over and feed the line.

In normal operation, the channels are switched to "P" the program bus. The monitor input selector is switched to "P" the output of the program amplifier. The line selector key is switched to "REG" the output of the program amplifier.

In emergency operation, the channel must be switched to "A", the audition bus. The monitor input must be switched to "A", the audition bus. The line selector key must be switched to "EMG", the output of the monitor amplifier.

When in the "EMG" position, no program cue is available for remote cue. This cue circuit is interrupted and used for the emergency feed.

Level adjustments can be accomplished with the monitor gain control if required.

The house monitoring speakers are not affected when the monitor amplifier is in emergency use. All of these feeds are compensated and do not change level with emergency operation. If a microphone channel is in use, the speaker is muted in emergency operation the same as in regular operation. The emergency operation of the console is so easy to use and excellent in quality that you might wish the program amplifier were not so dependable. It would be well to rehearse the changeover to emergency operation when permissible so that it can be accomplished gracefully should the occasion demand it.

PRINCIPLES AND THEORY OF OPERATION

This section is presented to give the engineer more detail on any unusual operation of part of the console. It is hoped that it will give the engineer a complete understanding of all of the circuits and enable him to maintain and trouble shoot the console effectively. The very obvious methods of operation will not be covered since they are common knowledge, or have been covered in previous sections of this instruction book.

FREQUENCY DETERMINING COMPONENTS

The Gatesway Console is a speech input system in itself and as many as four amplifiers are cascaded in some operations. The frequency response of each of these amplifiers would have to be nearly perfect to allow this cascading, yet keep the system within specifications, since any deviation in response will add. Slight deviations in response do occur in the production of the amplifiers so compensation must be employed to make each console meet specifications.

In some of the amplifiers this compensation is standard enough to give the normal value of the capacitor (small capacitors are generally used to compensate for response). In some cases it will be given an X value, determined by frequency response. In rare cases a standard value will be deleted or changed or a capacitor will be added where none is shown on the schematic diagram. Also in rare cases the value of a resistor must be changed to bring the system within specifications. The console as you receive it will be within all specifications, each one is given a complete test. The deviations that you may encounter are to make it perform accurately and are not errors, so do not change them unless you are compensating for abnormal conditions external to the console. If you need special compensation in your application and do not know the best method obtaining it, contact the Engineering Department of the Gates Radio Company. Have the complete details of the problem at hand and we will be happy to give assistance in solving it.

CUE-INTERCOM SYSTEM

838 0023 001, the schematic of the four stage amplifier and wiring diagram of this system, will aid in understanding the operation of the cue-intercom system. An interstage volume control is located between the first and second stage for gain and noise reduction to normal operating levels.

S21 is the eleven position selector for this system. The two front sections, next to the panel, are the sections used to talk out on any of the circuits that permit this. Circuits that do not permit talk-back simply do not connect to these sections. This is the interlocking method used. The two rear wafers are the sections used to listen to all of the circuits.

The remote lines connect to the rear wafers through 7500 ohm resistors. These resistors in combination with the 600 ohm winding of T1, the transformer, form bridging pads with approximately 40 db of attenuation. Thus, between any two remote lines there is 80 db of isolation. The listening positions of all four remote lines are jumpered together and connected directly to the listening section of S22, the talk-listen switch. These jumpers form the remote over-ride feature, enabling the con-

sole operator to hear the remote lines even if the selector is not switched to them. If this feature is not used or wanted, simply remove these jumpers.

The maximum gain of this amplifier is approximately 90 db. Since the input and output of the amplifier come in close proximity on the terminal board and at the talk-listen switch, wire dress is very important here. Should the amplifier try to oscillate, separate these pairs as much as possible. The grounding of the cue-intercom system is critical. Do not allow any part of the external speakers or system to be grounded, they are grounded in the console. Shielding of all external speaker lines is necessary to prevent hum and possible regeneration.

The frequency response of the amplifier is rolled off on both ends to provide the best compromise of cueing and intercom operation. Do not attempt to alter it without taking all of the circuit requirements into consideration.

CHANNEL 4 SELECTOR

The two microphones fed into channel 4 will probably be in different locations. The speaker muting is switched along with the microphones to mute only the speaker associated with the live microphone.

A-11023A shows the factory connection of all the muting facilities. Changes of muting sequence may be planned with the assistance of this drawing. If a control room microphone is used, the control room speaker must be muted with one of the three relays or one of the two additional relays available.

HIGH PASS FILTER

A-10515 shows the response curves and the schematic of this filter. It is a three section R-C filter, electrically located between the second and third stages of the program amplifier, immediately after the second half of the volume control. The fourth section of this switch is a potentiometer section to keep a constant loss at the upper frequencies, thus a constant amplifier gain. The switch is a shorting type to prevent clicks and pops.

SWITCH DETAIL DRAWINGS

A-10994, A-10995A and A-10996 are switch detail prints to show how the switching functions are accomplished. They also show the physical location of the contacts as viewed from the rear of the switch. The use of these detail prints along with the functional diagram, 842 3540 001, will explain most of the switching functions. Drawing A-11023A shows complete detail of the relay switching with the microphone channel switches.

MIXING SYSTEM

The mixing system consists of an eight channel mixer utilizing ladder type controls connected in a parallel, minimum loss type, mixing circuit.

PREAMPLIFIER

(See separate instruction sheet in this book).

PROGRAM AMPLIFIER

The M-6142C printed chassis program amplifier has four

stages. The first three stages use a pentode connected EF86 tube. The output stage uses a parallel connected 12AU7. Negative feed-back from a separate tertiary winding on the output transformer is applied to the cathode of V3. The master gain control is a tandem connected, high impedance interstage control (R4A-R4B). It is electrically connected between the first and second, and the second and third stages. It does a good job of keeping the signal to noise ratio acceptable.

VU METER AND ISOLATION PAD

A four inch illuminated VU meter is so arranged in the circuit that it indicates zero when an audio level of +8 is being fed into the program line. The VU meter is isolated from the external program circuit by a 4 db isolation pad. This pad isolates the meter from the various telephone line reactances that would cause erroneous readings at various audio frequencies.

MONITOR BOOSTER AMPLIFIER

The use of the booster amplifier permits the use of a gain control on the console panel, with good signal and noise reduction for normal levels. This signal and noise reduction permits the monitor amplifier to be fed directly from the audition bus with good quality, yet the interconnecting cable between the console and the power deck does not carry low level signal. The booster amplifier employs two cascaded voltage amplifier stages. One side of the output is grounded, so external grounds must be avoided.

INPUT TO TAPE RECORDERS

The audition bus is brought out to terminals 5 & 6 on section 6 of the main terminal board. This should be used to feed tape recorders from the console inputs that are not used simultaneously for broadcast. Tape recorder should bridge the output of the program line for simultaneous broadcasting and recording. The level of the bus is approximately -45 dbm level and the impedance is around 75 ohms. The bus should connect into the 150/250 ohm microphone input on the tape recorder, this will not load the bus excessively and lower the bus level for other circuits. If the level is higher than necessary, a series resistance, bridging pad or bridging transformer may be used to decrease the loading even more. If it is desired to switch the bus output to several tape recorders, one of the utility switches may be used for this function. This type of recording greatly expands the facilities of the console.

POWER AND RELAY DECK

The power deck contains the main power supply, the monitor amplifier and the relays. The schematic of the relay unit is 842 3539 001, the parts list is included in the parts list section.

Relay power is obtained from the B- return of the main power supply. All of the relays are connected in series and the coil is simply shorted out when one is operated. The voltage regulator prevents any change in the B+ circuit when one or more relays are operated. Sufficient reserve is provided to operate two more relays of the standard type. When ordering, please specify the type number furnished. The relays have one set of B (normally closed) and one set of A (normally open) contacts connected to

form a set of D (make before break) contacts. This set of D contacts is used to load the amplifier and break the speaker connection. They also have a set of A contacts to energize the warning lights when the speaker is muted. Last, they have a set of B contacts to break the cue-intercom speaker connection to prevent intercom use in the same studio with a live microphone.

Two additional relays may be used with the console, mounting holes are provided for the relays. Gates M-5255A is a relay expansion kit containing two relays. This kit may be ordered by the M-5255A number. Drawing 842 3539 001 the detail of the switching should be used to plan the wiring of the additional relays and their function. Shielded wire must be used on the intercom connections to these relays in the same manner as used on the standard relays.

All house monitor speakers must have matching transformers. These transformers should be 45/50 ohms to voice coil. If less than four speakers are to be used, the monitor amplifier output should be changed to 16 ohms. Drawing 842 3539 001 shows how this change can be accomplished. The back-loading resistors on each relay equal the primary impedance of the transformers they replace when muting. If one relay controls a single speaker, the back-load must equal the single primary. If more than one speaker is used on a relay, the back-load must equal the parallel or series combination. The parallel combination of all back-loads must equal approximately 8 ohms or 16 ohms, if connected this way.

REGULATED POWER SUPPLY (Part of M-5548F)

In operation, the conductance of V1, the series regulator tube, is controlled by the sharp cut-off pentode, V2. The gaseous regulator tube, V3, established the cathode of V2 at a constant 150 volts, regardless of output voltage.

If a change in load occurs, causing the output voltage to increase, the grid of V2 becomes more positive, increasing the plate current through this tube and increasing the voltage drop across plate resistor R2. Thus, the voltage at the grids of regulator tube, V1, is reduced, increasing the internal voltage drop in this tube and compensating for the original rise in output voltage. A decrease in output voltage will cause the opposite effect.

A positive bias is applied through R101 (the hum balance control) to reduce hum in the amplifier tubes due to filament-cathode conduction. R101 also balances the filaments electrically to further reduce or cancel any remaining hum.

The taps on the primary of power transformer, T101, provide a means of maintaining the secondary voltage at the minimum value required for proper operation of the regulating circuit with the lowest line voltage. The correct tap is determined by the line voltage conditions at the particular location.

CAUTION: Do not remove the load from the power supply with the power turned on.

MONITOR AMPLIFIER (Part of M-5548F)

The monitor amplifier has three stages. The first stage is one-half of a 12AX7. The other half of this tube is not used. Another 12AX7 is used for the second stage.

This tube is used in a phase-inverter circuit to drive the third stage, two EL84's in push-pull, connected into the output transformer.

Negative feedback is used between the output transformer and the cathode of the first half of the phase inverter. This lowers the output impedance, gives good load regulation and reduces distortion in the output section.

MAXIMUM AND MINIMUM VOLTAGES

The Gatesway Console is designed to operate with an input line voltage of 105/125 volts, 50/60 cycles, single phase. The operation of the console is not guaranteed beyond these limits and damage may occur with voltage above 125 volts.

The console is designed to operate normally with approximately +310 volts out of the power supply. This voltage will remain constant with a normal load unless the line voltage gets very low. Extreme variations in line voltage (more than $\pm 10\%$ of normal) can not be tolerated by the power supply. However, $\pm 10\%$ or less of normal line voltage is easily handled.

The mid-primary tap (TS1-3) is connected at the factory and should be used in applications where the line voltage ranges from 105 to 125 volts. In locations with voltage low enough to cause the power supply to drop out of regulation, use TS1-2. In locations with line voltages centered around 120 volts or higher, use TS1-5.

The B⁺ voltage should be approximately +310 volts, as explained above. If the voltage exceeds this value it will shorten the tube life of many of the amplifier tubes and will gain nothing. The filament voltage should be held within the range of 5.7 volts to 6.9 volts. If necessary, this voltage may be adjusted by placing the proper size of resistor in series with the filament lines. An alternate method is to insert a sufficient length of small wire in series with the feed (or use small wire to feed the units) to drop the voltage to the desired value. The filament voltage may be raised by changing the primary tap (do not exceed 6.9 volts), if necessary, on low line voltages.

The only requirement for the small wire is that it does not heat up enough to damage the insulation. Ten percent line variation will not cause the filament voltage to get out of the prescribed limits if the preceding instructions are followed. Laboratory tests of all the tubes used in the console prove that they can tolerate far wider limits than this. If these precautions are followed, along with the suggestions on "Ambient Temperature" under the "Installation" section, the console should give very satisfactory service.

MAINTENANCE

Without routine maintenance even the finest equipment soon becomes erratic or inoperative. The Gatesway Console is no exception to this rule. The maintenance schedule is subject to conditions that vary with each installation, thus must be planned by the station engineer. Most stations set up a schedule similar to automobile service schedules: Some sections get weekly maintenance, some sections monthly or on a several weeks basis. Proof of Performance measurements are taken at

least every year. We strongly recommend that the station engineer plan a routine maintenance schedule and make every effort to follow it carefully.

Present day vacuum tubes are very reliable compared to those of a few years ago. Yet, some fail in a relative short time due to some defect in it, or rough handling at some time. In the design of the console every effort was made to keep all of the components, including all tubes, well below maximum ratings. Unless some component has suffered a major change, the circuitry will not cause tube failure. Routine dynamic or emission tube checking will spot tubes that are liable to give trouble. Substitution of new tubes in the console will show up old ones that have started to go bad. Gates TK-451 tube kit should be ordered for a complete set of spares.

TUBE SOCKET VOLTAGES

Typical tube voltages are shown on the schematic diagrams. These voltages are subject to tube characteristic variations and age. In most cases a variation of 30% from these readings is permissible. When in doubt, try several tubes in the socket and measure the voltages of each to establish an average in your location and with your particular test meter. All D.C. measurements were taken with a 20,000 ohm per volt Simpson 260 meter. Vacuum tube meters will give higher readings since the meter will not load some of the high impedance circuits that the Model 260 loads. All D.C. readings were taken with no signals applied.

RMS signal voltages were measured with a vacuum tube voltmeter under the conditions outlined on the schematic diagram.

Regulated B+ Voltages	+310 Volts, D.C.
All Filament Voltages	between 5.7 & 6.9 Volts A.C.
Input Line Voltage	105/125 Volts, 50/60 cycles, single phase.
Relay Supply Voltage	21 Volts, 3 relays energized 14 volts, 2 relays energized 7 volts, 1 relay energized 0 volts, no relays energized
Filament Bias Voltage	+24 Volts, D.C.
Line Power Consumption	115 Watts @ 115 Volts
Power Supply Load	138 ma. at 310 Volts 85 ma. for the monitoring amplifier 53 ma. for the console proper

OTHER COMPONENTS

The channel attenuators are step type low impedance attenuators. They require cleaning about four times a year in the average location. A well air conditioned room would allow longer periods between cleaning. A very dusty location would require more frequent cleaning. The attenuator contacts should be cleaned and lubricated by using Davenol (sometimes called Daven Oil.) A soft, lint-free cloth should be used to remove the dirty accumulation from the contact surfaces. Davenol is inexpensive and may be purchased from the Gates Radio Company.

The relays and channel lever keys are high quality telephone type. They are selected for long life and trouble-free service. The contacts are self-wiping and

every day use will keep these contacts burnished. The contacts on the keys and relays that receive infrequent use can be cleaned by operating the equipment several times. Periodic operation of unused equipment will keep the contacts clean. In cases of stubborn trouble use a contact burnishing tool. Such a tool, Gates TM-1, is listed in the general catalog.

Abrasive papers, files, and grease solvents should never be used on these contacts. Grease or oil should not be used on relay or key contacts. This would make them collect dust, get gummy, cause contact burning, and possible failure. The Centralab lever keys have excellent wiping action and will probably not require any cleaning. If one of these keys is damaged, it is better to replace it than to attempt to repair it. Use the parts list for the description, if it is necessary to order a new one.

Electrolytic capacitors have been perfected to the point that they probably are subject to no maintenance. If one does become defective it is better to catch it in routine maintenance than to let it cause loss of air time. Perhaps an annual or semi-annual check would be justified. The main filter in the regulated power supply is plug-in and may be changed readily. To check it: Insert a new one and measure the voltage on the plates of the 6080 tube. If this voltage increases 20 volts or more with the new capacitor, the old one should be considered unfit for service.

C102, the 250 Volt, 50 mfd. capacitor may be checked by bridging it with a new capacitor. With all relays energized (all microphones off) the voltage should be about 21 volts. If the new capacitor makes a change of 3 volts or more, replace C102. Decoupling capacitors may be checked by testing the console at maximum gain as outlined in the specification section. If any of the decoupling capacitors are defective, oscillation or motor-boating will occur. Parallel each section of the capacitors individually with the rated capacity (or close to rated capacity), replace capacitors that need the additional capacity to prevent oscillation. Caution must be used when checking the monitoring amplifier circuit, the maximum gain of 100 db must not be exceeded or the test is not valid and oscillation may occur with all good components.

MODIFICATION FOR EXTRA FACILITIES

If you have glanced through other sections of the instruction book, you are aware that there are many facilities. We have tried to include all that are needed in most installations. Yet some installations may demand facilities that are not common, so this chapter is devoted to a summary of the modifications available and some of the suggested uses. Plan your modification carefully and allot sufficient time to complete it so that it will be well executed and will not be a source of trouble.

UTILITY KEYS

These keys may be used to expand any section of the console necessary to fit your particular installation. A multi-section terminal board is provided on the rear of the cabinet (inside) to connect to additional incoming circuits for signal checking. A maximum voltage of 310 volts DC or 230 volts AC may be applied to the switches and the terminal board. The maximum current on the

switches should be limited to 100 ma. AC or DC. All wires carrying AC should be in twisted shielded pair, and the wire should be physically isolated from program carrying lines as covered under "Installation". Switch contacts carrying voltages in excess of 25 volts, or connected to circuits that grounding would cause damage to components or the supply, should be insulated by the use of spaghetti, plastic tape or a suitable cover.

Utility key 5 may be wired in the same manner as S1, the microphone selector key into channel 4, to provide two microphones into channel 3. Muting may also be switched, as on S1, (adjacent relays must be used) or may be standard on channel 3 if both microphones are used in the same location. If it is desired to switch additional microphones into other channels, the three position utility keys may be used if the muting is not switched. If muting must also be switched, the standard utility keys may be replaced by the two position, four circuit switches. Order Gates Type A-10900-6 switches, listed in the general catalog. The front panel escutcheon plates must be removed to change switches.

The intercom facilities may be expanded by connecting the utility position of the selector switch to the arm of a three position utility switch, thus making three utility circuits available for intercom service. These may be used for more studio intercom circuits, or may be used to service offices and maintenance rooms. By making one position of the utility switch series through to the arm of another one, two extra positions may be picked up for each switch used, yet the stations may be selected individually. M5303 intercom stations, containing the speaker and matching transformer in a plastic cabinet are available for additional stations.

Utility Switches used with bridging pads may be used to feed signal into one or several tape recorders from the program line. They may also be used to direct the output of the audition bus to several recorders as explained in the section labeled "Input to Tape Recorders" under the chapter "Theory of Operation". They may also be used to expand the tape playback facilities if the four standard switches are insufficient. They may be wired in the same manner as the standard switches or may be used as three position selectors to feed one of the standard switches.

The utility switches may also be used to expand the remote line facilities. They may be wired like the standard ones for individual lines, but the talk-back facilities will be lacking. They may be wired as three position selectors into a standard remote line switch and the talk-back facilities retained when the proper line is selected. Perhaps a better method of handling more remote lines would be to bring them into a patch panel and patch them into the regular remote line input switches. The patching would allow full use of the talk-back and over-ride facilities of the cue-intercom amplifier.

Control of turntable and tape machine motors may be accomplished with the utility switches if slave relays are used for the actual control. The motor currents should not be switched with the switches directly, since the inductive surges would probably damage the contacts and the currents may induce hum in the program circuits in the console. The Gates A-11227 relay may be used as a slave relay for this operation. It has a low current

115 volt, 60 cycle coil, and has one set of A (normally open) contacts. The relay contacts may be used to parallel the normal turntable or tape machine starting contacts, thus local or remote control is possible. The machines may be cued and switched on from the console, resulting in better operation and less operator confusion. Most tape machines have full remote control facilities available in the form of a small remote control box or switches, investigate these before modifying the console. Perhaps you need more than the machine starting feature outline, or the remote control can be combined with the utility keys for more complex operation, if necessary.

ADDITIONAL MICROPHONE CHANNEL

The Gatesway Console is furnished with four microphone channels as standard, but the fifth one is easily installed if required. The monitor gain control must be removed from the front panel and placed in the hole provided for it in the filler plate on amplifier deck. The long grid leads may be removed and the control wired with short unshielded wires. The monitor input selection must be transferred from the present lever key to one of the utility keys. Neither the gain control or selector key are used to any extent in normal operation so this is a small sacrifice as far as the operator is concerned.

An additional preamplifier and isolation shield must be ordered, this is listed as a Gates M-5304A Preamplifier Kit. The channel control required is a Gates A-9703-1 attenuator, 150/300 ohms.

Install the preamplifier and shield in the space provided on the amplifier strip. Wire it to section 5 of the terminal board in the same manner as the other four are wired. Jumper the B+, B- and filament feed from the adjacent preamplifier. Install the attenuator on the panel in place of the monitor gain control. Remove all wiring and jumper the former monitor input selector key to the other channel keys. Complete the wiring of this key exactly the same way as the other microphone channel keys are wired. Muting wiring can be wired to terminals 1 and 2 on "TIE 1". This modification provides another full microphone channel with all the quality and facilities provided by the standard four.

If another full microphone channel is possible, but at the loss of a turntable, tape, or remote channel, we strongly recommend that you weigh all the disadvantages against the advantages before you do this. We feel that switching microphones into one of the standard microphone channels would be much better. The loss of a medium level channel and associated circuitry would result in a loss of much of the flexibility of the console. A space for the preamplifier and the shield is provided between the standard preamplifiers and the cue-intercom amplifier chassis. The medium level channel keys have muting contacts on them as standard. Wiring will be very similar to the wiring of the fifth microphone channel as described above.

ADDITIONAL SPEAKER MUTING RELAYS

Two additional relays may be installed. The installation is covered in the section labeled "Power Deck" under the "Principles and Theory of Operation" chapter.

PATCH PANEL FACILITIES

All of the important internal circuits of the console are terminated and jumpered on the main terminal board. These jumpers may be removed and normalling jacks wired in place of them. This would permit patching around sections of the console, feeding the console signal to other equipment and feeding signals into selected sections of the console. Of course, any of the inputs or outputs may normal through patch panels before connecting to the external connections. The proper use of patch panels will make the difference between a very versatile and a rather restricted installation. On the other hand, if patch panel facilities are not required, their elimination will reduce the number of possible operational errors. The station engineer must weigh all of the factors carefully and act accordingly.

If the patch panels are used, they must be wired correctly. They should be wired so that the polarity of the circuits are kept phased properly in normalling and patching operation. Balanced circuits may be phased in the opposite direction to minimize noise or hum, unbalanced circuits can not be phased for opposite polarity or both sides will ground out. The patch panel should not introduce grounds in any of the circuits, circuits that need grounds will have them as explained in the section labeled "Grounding Circuits" under "Installation".

Circuits of more than 40 db difference in level should be separated in the patch panels. It is recommended that the jacks be segregated into low level, medium level and high level groups and all wiring attached to the different groups be cabled separately. The cables must have sufficient physical separation to prevent cross-talk as explained in "Installation". If the circuits on the patch panel were located in a progressive order as located in the console or system, patching would be much easier.

TURNTABLE PREAMPLIFIERS

We do not recommend the use of microphone preamplifiers for turntable preamplifiers. The normal 40 db gain of a microphone preamplifier is about 15 to 20 db low for good operation. The level out of present day turntable equalizers is in the region of 75 dbm level: The preamplifier should be close to the equalizer to achieve minimum noise pickup. We recommend a turntable preamplifier for this service and believe that it should be installed in the turntable cabinet or desk. Gates M5530 amplifier is recommended for use with most equalizers, we also have an M6244 preamplifier with internal equalization. The M6244 is for use with the GE variable reluctance cartridge only, it has a self-contained power supply and a filter selection switch with the three most popular standard curves available.

If the installation demands that the turntable preamplifiers be mounted in the console, and the two additional preamplifiers are not used for microphone preamplifiers as described previously, they may be installed in the two spaces provided. The Gates M5304A preamplifier kit which includes the isolation shield, should be ordered. They may be jumpered to the adjacent preamplifiers for power and connected similar to the microphone preamplifiers for input and output connections. The input may be connected for 30/50 or 150/200/250 ohms, the output must be connected for 150 ohms to match the input to the channel attenuator.

We would like to emphasize that all modifications be carefully studied for possible sources of operational or technical trouble before starting the job. Sufficient time must be allowed to permit the modification to be installed and thoroughly checked before it is used or any of the circuits it affects. Make a permanent record of the modification by making up drawings, or marking up existing drawings, and any written description that will help you remember all of the details. The record should be sufficient to enable other members of your staff to understand it also. Explain the new operation to the operators so that they will not make mistakes. Include all necessary parts on your maintenance schedule.

ORDERING REPLACEMENT PARTS

When ordering a replacement component please refer to the parts list in this instruction book. Identify the component by its symbol number and, if possible, its Gates part number. The type of equipment in which the part is used is also necessary. This procedure will insure the customer receiving the correct component and at the earliest possible date.

PARTS LIST

Symbol No.	Gates Stock No.	Description
AB1	992 1292 001	Monitor Booster Amplifier
AL1	994 6142 004	Program Amplifier
AP1, AP2, AP3, AP4	994 5215 001	Preamplifier
AQ1	994 5742 001	Cueing Amplifier
AT1, AT2, AT3, AT4 AT5, AT6, AT7, AT8	554 0188 000	Attenuator, 150/300 ohms
	554 0182 000	Attenuator, 150/300 ohms with cue position
AT9, AT10, AT11, AT12, AT13, AT15, AT16		Pads (Part of S21)
AT14	911 0876 001	Pad, 33 DB, 13K/600
AT17	937 7942 002	Pad, 4DB, Isolation Pad, VU Pad
AT18	931 6242 020	Pad, 45 DB, 54K/600
AT19	991 0855 001	Pad 20 DB, 600/150 ohms
AT20	550 0160 000	Control, 10K ohm
	506 0005 000	Cap., .1 mfd., 200 V.
FL1	911 1149 001	High Pass Filter Switch Assembly
J1, J2	612 0279 000	Jack
LS1	722 0008 000	3" Speaker
M1	630 0072 000	VU Meter, Scale B

Symbol No.	Gates Stock No.	Description	Symbol No.	Gates Stock No.	Description
R1	550 0198 000	Control, Dual 100K ohms	XV1, XV2,		
R3	550 0169 000	Control, 100K ohms	XV3, XV4	404 0059 000	Socket
	540 0044 000	Res., 620 ohms, 1/2W, 5%			
	540 0056 000	Res., 2000 ohms, 1/2W, 5%			
	540 0035 000	Res., 270 ohms, 1/2W, 5%			
	540 0043 000	Res., 560 ohms, 1/2W, 5%			
	540 0036 000	Res., 300 ohms, 1/2W, 5%			
	540 0046 000	Res., 750 ohms, 1/2W, 5%			
	540 0190 000	Res., 10K ohms, 1/2W, 10%			
		(B Res. for Monitor Booster)			
S1, S30	602 0007 000	Switch			
S2, S3, S4, S5, S6, S7, S8, S9, S10, S11, S12 S26, S27, S28, S29	602 0005 000	Switch			
S13, S14, S15, S16, S17, S18, S19, S20, S24 S21	602 0011 000	Lever Key Switch			
	911 1150 001	Cue Selector Switch & Pad Assembly			
S22	602 0006 000	Switch			
S23	602 0012 000	Lever Key Switch			
S25	600 0150 000	Switch #1414 (Part of FL1)			
T1	478 0159 000	Isolation Transformer			
T2, T3	478 0009 000	Transformer			
TB1	614 0381 000	Terminal Board			
TB2	614 0379 000	Terminal Board			
TB3	614 0052 000	Terminal Board			
BASIC PROGRAM AMPLIFIER, M6142C					
C1	524 0079 000	Cap., 15-15-10 mfd., 450 V.			
C2	524 0062 000	Cap., 20-20 mfd., 450 V.			
C4	506 0026 000	Cap., .47 mfd., 200 V.			
C5, C7, C8 C6	506 0028 000	Cap., .1 mfd., 400 V. Cap., (Det. By Freq. Re- sponse)			
C10	506 0009 000	Cap., 2.0 mfd., 200 V.			
C3	516 0083 000	Cap., .015 uf., 600V.			
R1, R5	540 0179 000	Res., 1200 ohm, 1/2W, 10%			
R2, R6 R3, R7, R12, R13 (R4A/B)	540 0214 000	Res., 1 megohm, 1/2W, 10%			
	540 0204 000	Res., 150K ohm, 1/2W, 10%			
	550 0198 000	100K ohm Control, Dual			
R8	540 0056 000	Res., 2000 ohm, 1/2W, 5%			
R9	540 0190 000	Res., 10K ohm, 1/2W, 10%			
R10	540 0188 000	Res., 6800 ohm, 1/2W, 10%			
R11	540 0213 000	Res., 820K ohm, 1/2W, 10%			
R14	540 0046 000	Res., 750 ohm, 1/2W, 5%			
R15	540 0061 000	Res., 3300 ohm, 1/2W, 5%			
R17	540 0202 000	Res., 100K ohm, 1/2W, 10%			
R19	540 0166 000	Res., 100 ohm, 1/2W, 10%			
R22	540 0049 000	Res., 1000 ohm, 1/2W, 5%			
T1	478 0143 000	Input Transformer			
T2	478 0120 000	Output Transformer			
V1, V2, V3 V4	370 0144 000	Tube, EF86/6267			
	370 0195 000	Tube, 12AU7A			
					PRINTED WIRING, MON-BOOSTER AMPLIFIER, 992 1292 001
Symbol No.	Gates Stock No.	Description	Symbol No.	Gates Stock No.	Description
C1A/B	524 0062 000	Cap., 20-20 mfd., 450 V.			
C2	506 0028 000	Cap., .1 mfd., 400 V.			
C3	522 0120 000	Cap., 8 mfd., 350 V.			
C4	508 0033 000	Cap., .15 mfd., 200 V.			
C5	500 0031 000	Cap., .0002 mfd., 500 V.			
C5	500 0035 000	Cap., .00027 mfd., 500 V.			
R1	540 0182 000	Res., 2200 ohm, 1/2W., 10%			
R2	540 0097 000	Res., 100K ohm, 1/2W., 5%			
R3	540 0205 000	Res., 180K ohm, 1/2W., 10%			
R4	540 0053 000	Res., 1500 ohm, 1/2W., 5%			
R5, R6	540 0073 000	Res., 10K ohm, 1/2W., 5%			
R7	540 0196 000	Res., 33K ohm, 1/2W., 10%			
R8	540 0192 000	Res., 15K ohm, 1/2W. 10%			
T1	478 0145 000	Transformer, Input			
V1	370 0116 000	Tube, 12AX7			
XV1	404 0059 000	Socket, 9 pin			
CUEING AMPLIFIER, M5742A					
C101	522 0002 000	Cap., 25 mfd., 25V.			
C102	524 0079 000	Cap., 15-15-10 mfd., 450 V.			
C103, C106, C107	506 0013 000	Cap., .05 mfd., 400 (W) V.			
C104	506 0005 000	Cap., .1 uf., 200 V.			
C105	508 0205 000	Cap., .005 mfd., 400 V.			
C108	516 0054 000	Cap., .001 uf., 1 KV			
R101	540 0090 000	Res., 51K ohm, 1/2W., 5%			
R102	540 0179 000	Res., 1200 ohm, 1/2W., 10%			
R104	540 0213 000	Res., 820K ohm, 1/2W., 10%			
R105, R108, R109, R112, R113	540 0204 000	Res., 150K ohm, 1/2W., 10%			
R106	550 0169 000	Control, 100K ohm			
R107, R110	540 0182 000	Res., 2200 ohm, 1/2W., 10%			
R111	540 0480 000	Res., 10K ohm, 1 W., 10%			
R114	540 0470 000	Res., 1500 ohm, 1W., 10%			
R115	540 0196 000	Res., 33K ohm, 1/2W., 10%			
R116	540 0468 000	Res., 1000 ohm, 1 W., 10%			
T101	478 0002 000	Input Transformer			
T102	478 0098 000	Output Transformer			
V101	370 0144 000	Tube, EF86/6267			
V102	370 0116 000	Tube, 12AX7			
V103	370 0029 000	Tube, 6AK6			
XV101, XV102	404 0040 000	Socket			
XV103	404 0032 000	Socket			
PRINTED WIRING MONITOR AMPLIFIER					
C1 A/B	524 0062 000	Cap., 20-20 mfd., 450 V.			

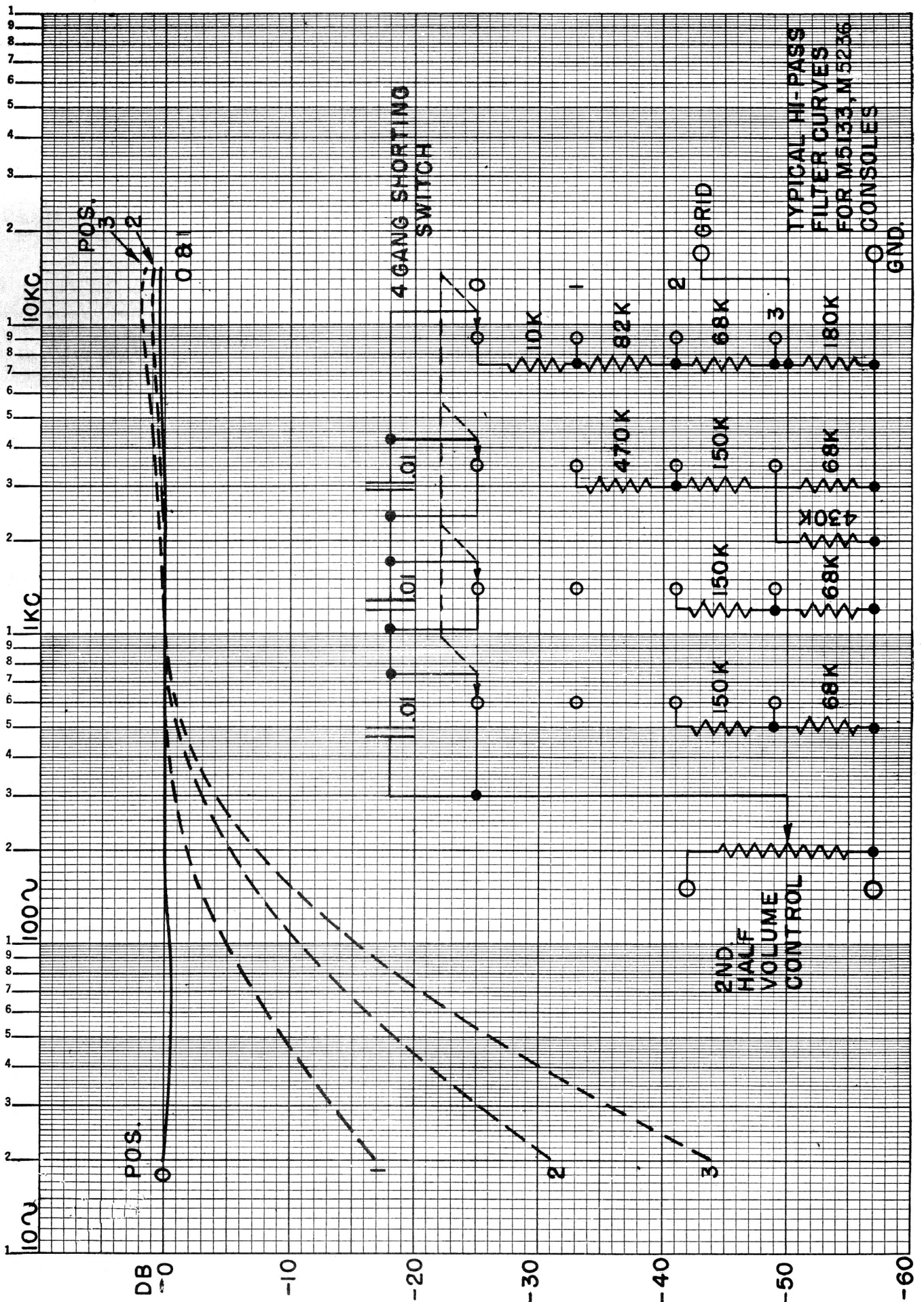

MOSSMAN SERIES 4800

POS. 1

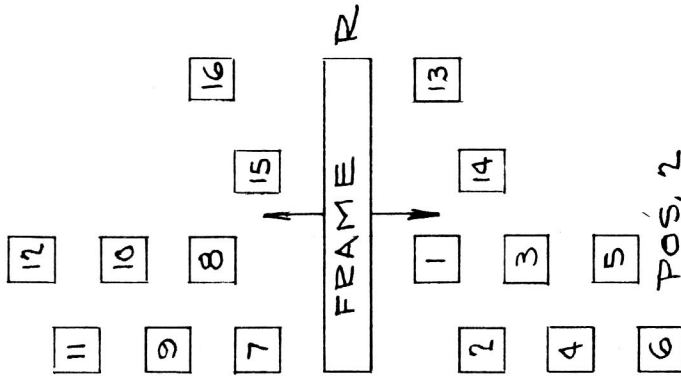

PART-1 AS SHOWN
 PART-2 CONTACTS #13, 14,
 15 AND 16 WILL NOT BE USED
 S17-18-19-20 PART-2

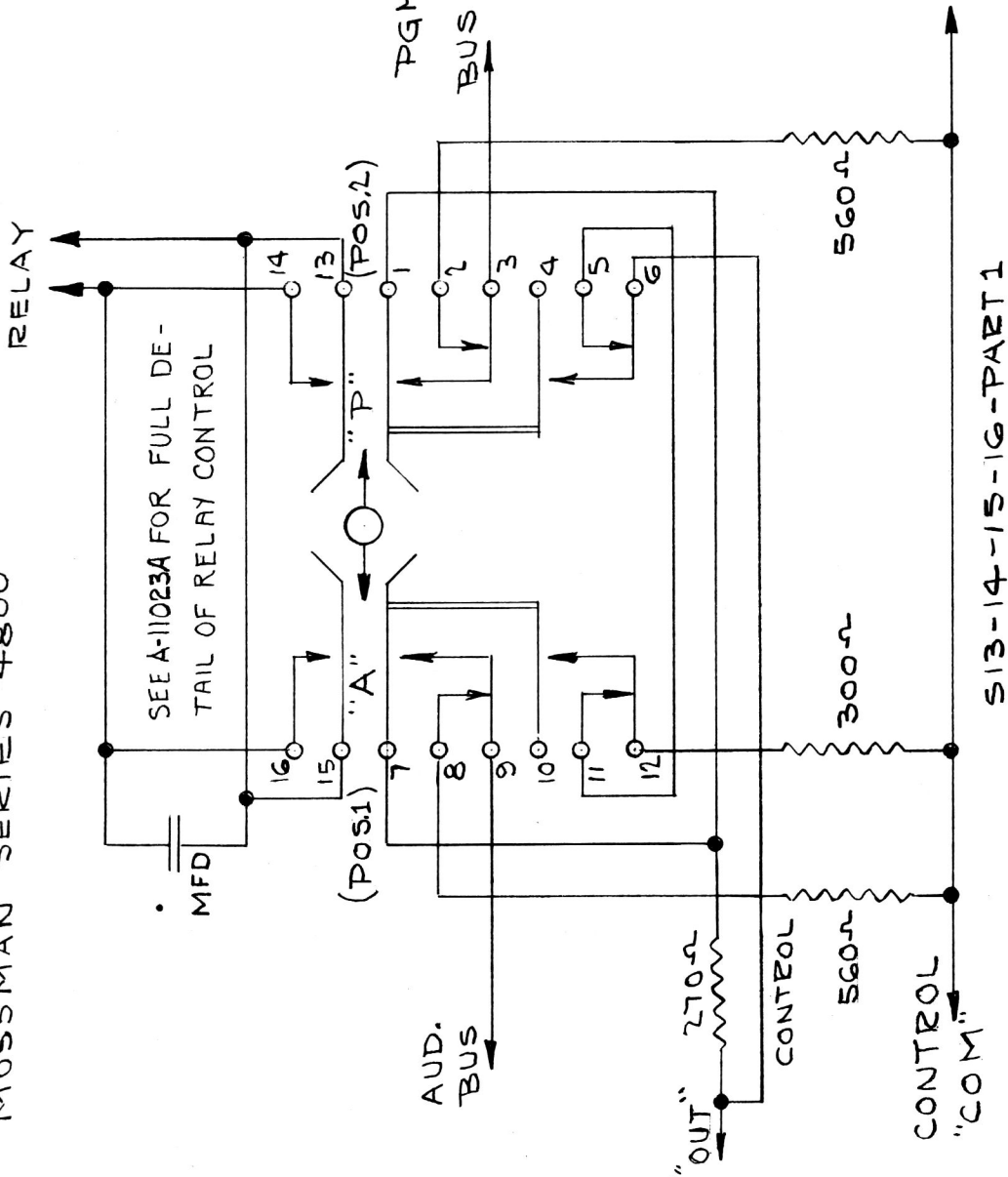

SWITCH
 POS. 1 LOCKING L: 2 FORM D
 R: 1 FORM A
 POS. 2 LOCKING L: 2 FORM D
 R: 1 FORM A

**SCHEMATIC MIXING SYSTEM ONE
 SECTION GATEWAY CONSOLE M5133**

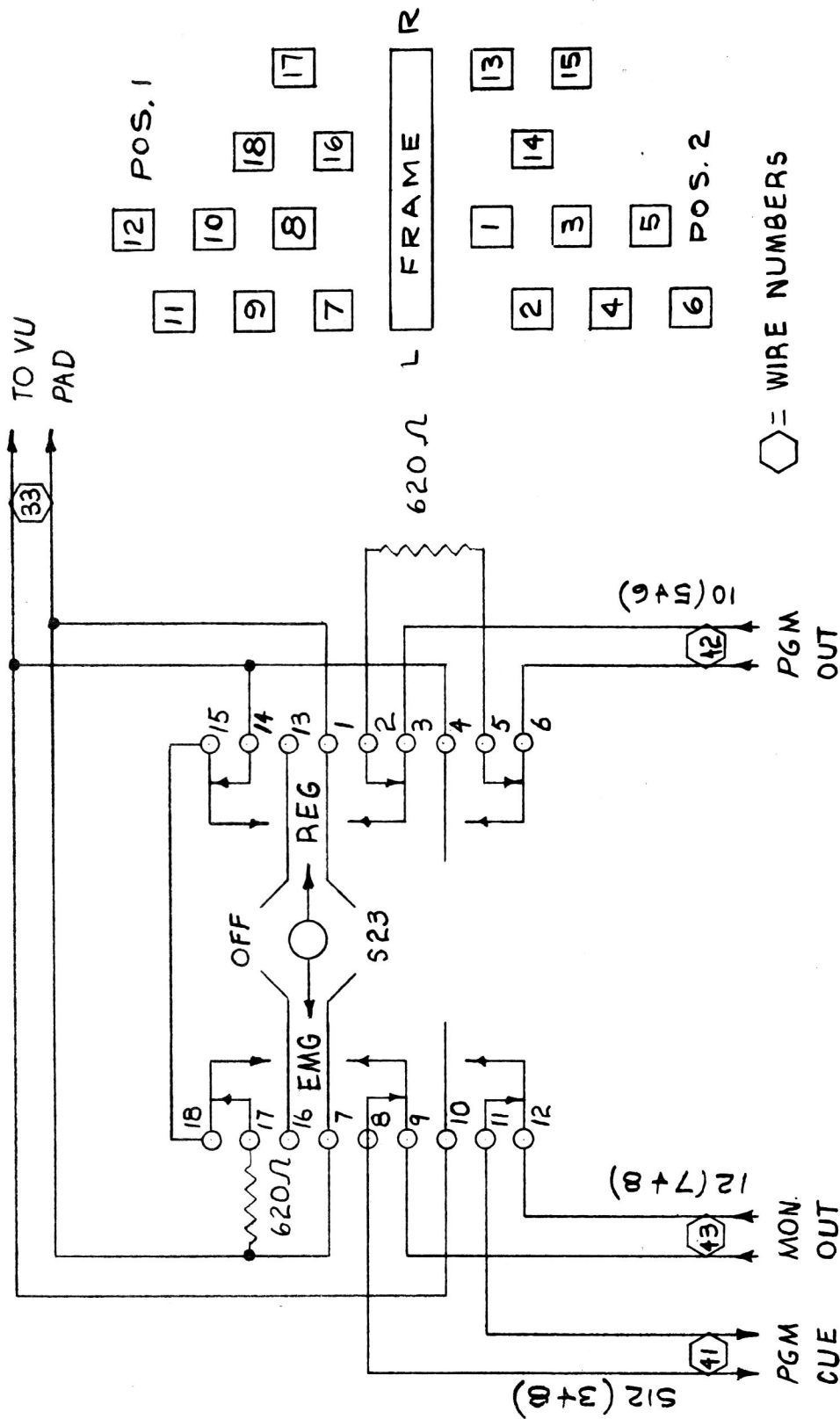

MOSSMAN SERIES 4800
 POS. 1 LOCKING L: 2 FORM "D"
 R: 1 FORM "D"
 POS. 2 LOCKING L: 2 FORM "D"
 R: 1 FORM "D"

PROGRAM LINE SWITCH SECTION
GATESWAY CONSOLE M5133A

MOSSMAN SERIES 4800

POS. 1 LOCKING L: 2 FORM "D"
 R: 1 FORM "A"
 POS. 2 LOCKING L: 2 FORM "D"
 R: 1 FORM "A"

MON. IN
 7-1+2

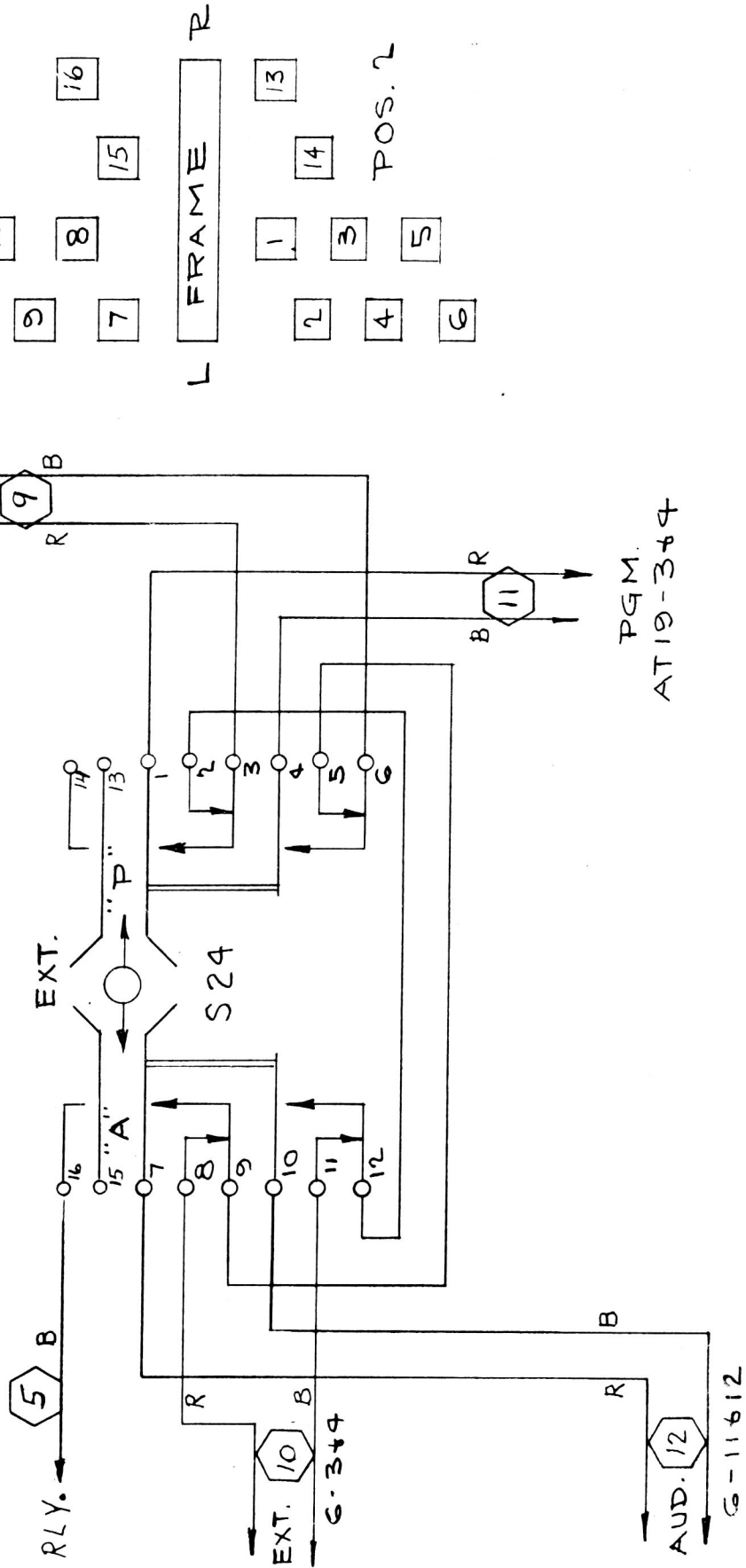

⬡ = WIRE NUMBERS

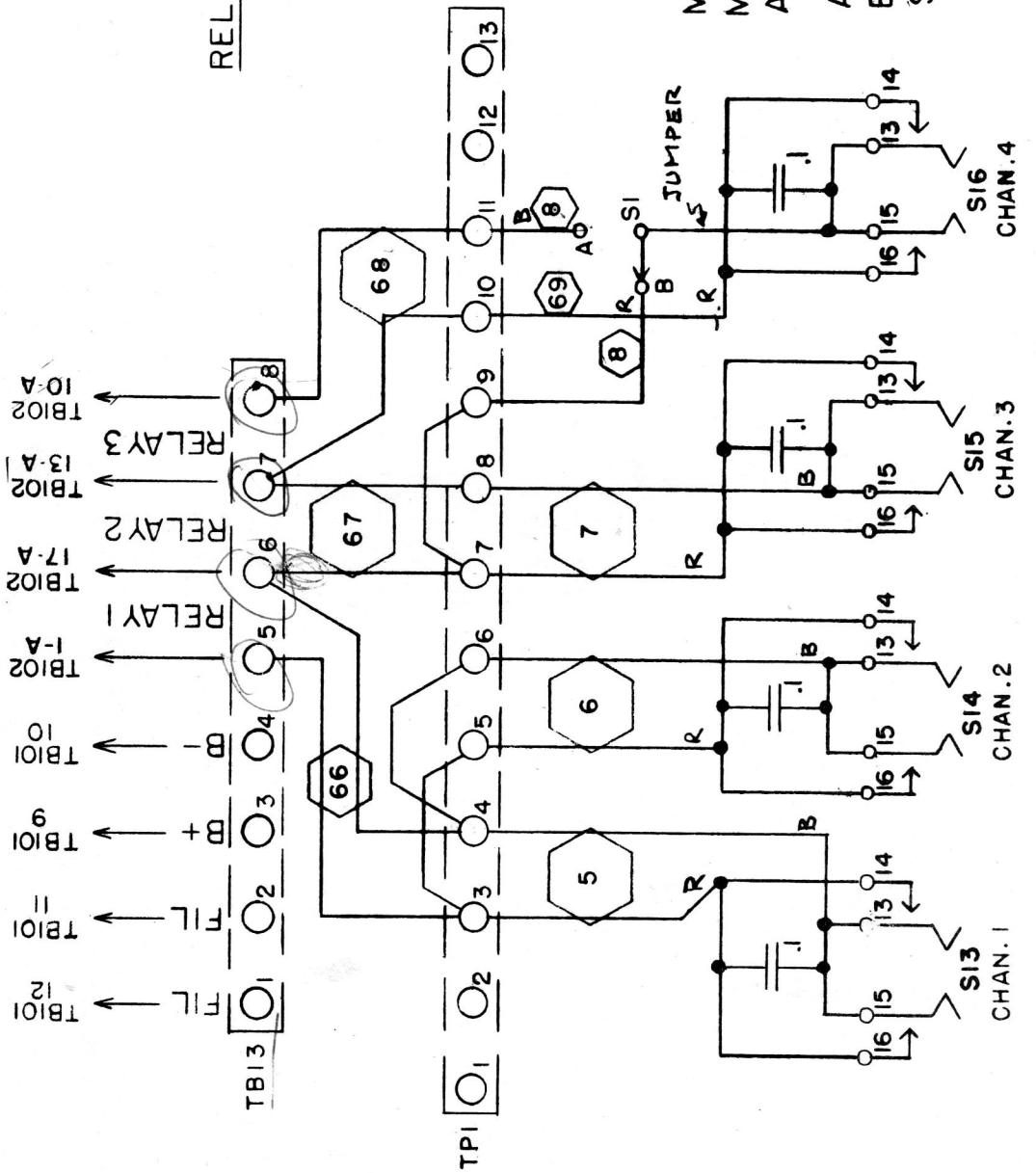

RELAY NO.	TERM. NO.
1	5 & 6
2	6 & 7
3	7 & 8

FACTORY CODING
 CHAN. 1 & 2 — RELAY 1
 CHAN. 3 & 4 — RELAY 2
 CHAN. 4A — RELAY 3

MUTING FOR CHAN. 4 (A & B) MUST BE ON THE SAME OR, ADJACENT RELAY.

ALL OTHER JUMPERS MAY BE CHANGED FOR ANY SEQUENCE OF OPERATION

⬡ = WIRE NUMBERS

RELAY SWITCHING DETAIL
 GATESWAY CONSOLE M5133A

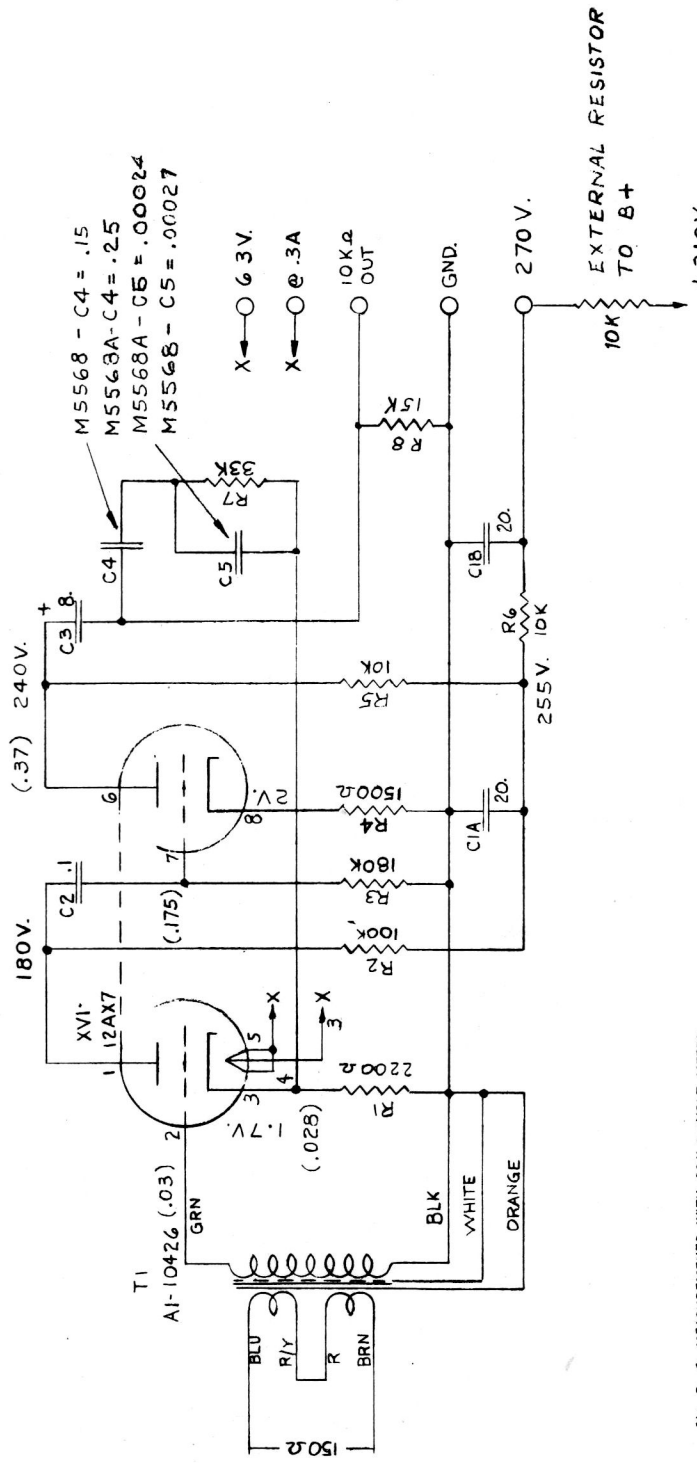

ALL D. C. MEASUREMENTS WITH 250 KΩ/VOLT METER
 ALL R.M.S SIGNALS () MEASURED WITH V. T. V. M.
 ALLOW 20% ERROR ON MOST READINGS.

**SCHEMATIC OF MONITOR BOOSTER AMPLIFIER
 M5568, M5568A**

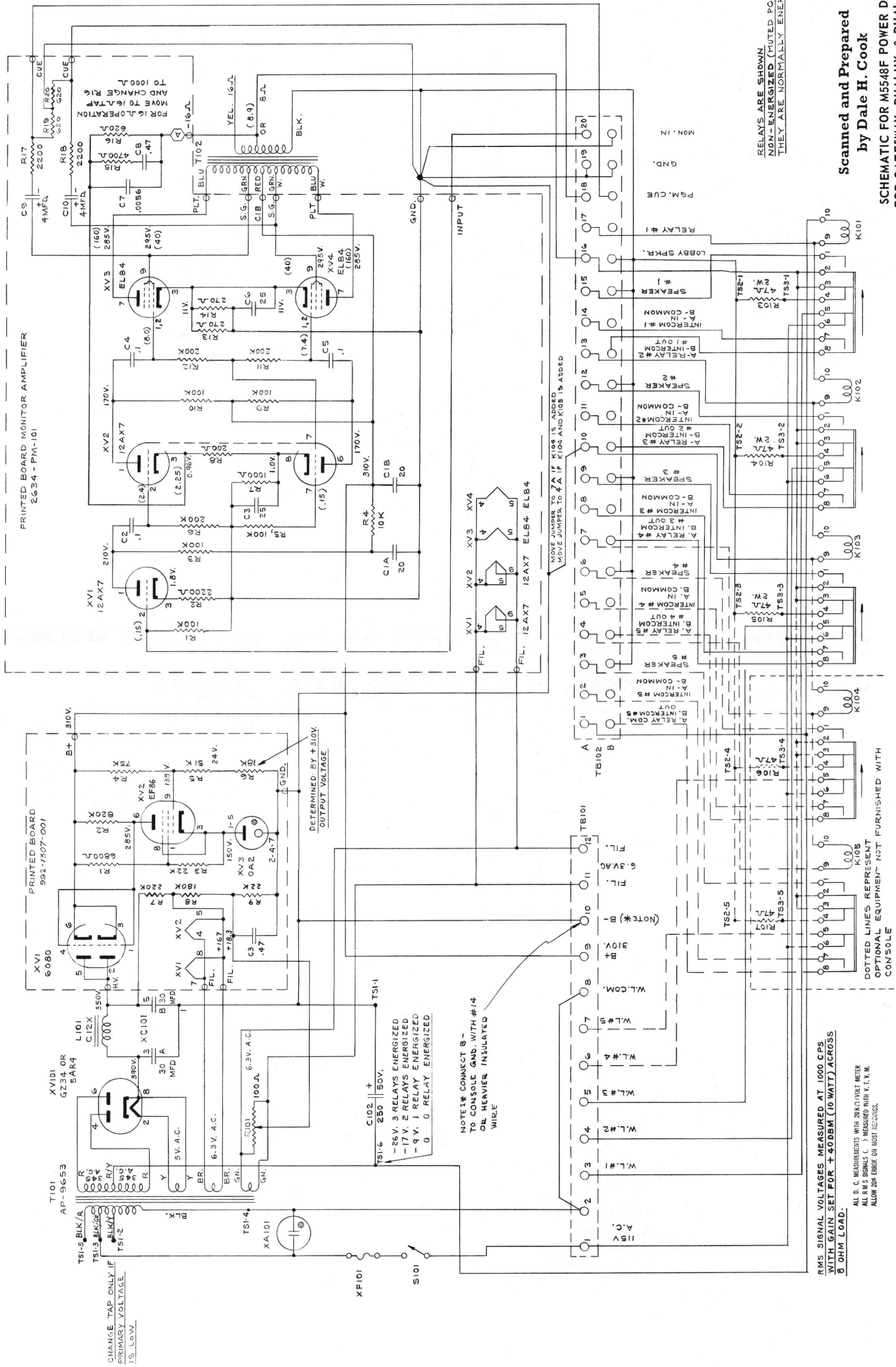

PRINTED BOARD MONITOR AMPLIFIER
2634 - PM-101

PRINTED BOARD
992-1507-001

AP-9653

CHANGE TAP ONLY IF
PRIMARY VOLTAGE
IS LOW

DETERMINED BY +310V
OUTPUT VOLTAGE

NOTE: CONNECT B-
TO CONSOLE GND. WITH #1/4
OR HEAVIER INSULATED
WIRE

MOVE JUMPER TO 2 IF K104 IS USED
MOVE JUMPER TO 4 IF K104 AND K105 IS ADDED

RMS SIGNAL VOLTAGES MEASURED AT 1000 CPS
WITH GAIN SET FOR +40DBM (10 WATT) ACROSS
8 OHM LOAD.

ALL D.C. MEASUREMENTS WITH 20K-Ω VOLT METER
AC RMS SIGNALS AS MEASURED WITH Y.T.M.
ALLOW FOR ERROR ON MOST RECORDS

DOTTED LINES REPRESENT
OPTIONAL EQUIPMENT - NOT FURNISHED WITH
CONSOLE

RELAYS ARE SHOWN
NON-ENERGIZED (HUTED POSITION)
THEY ARE NORMALLY ENERGIZED

Scanned and Prepared
by Dale H. Cook

SCHEMATIC FOR M5548F POWER DECK
FOR GATESWAY, DUALUX, & DUAL T.V.

RMS VALUES MEASURED WITH -10 DBM
 1000 CPS, 150 OHM SIGNAL TO TERMINALS
 8-3#4 ON CONSOLE CHAN. 5 FADE
 (A15) IN CUE POSITION, INTERCOM SWITCH
 (S21) IN "T.T. CUE" POSITION, R106 SET AT
 MID-RANGE (12 O'CLOCK)

ALL D.C. MEASUREMENTS WITH 20K Ω VOLT METER
 ALL RMS SIGNALS (.707) MEASURED WITH V.T.V.M.
 ALLOW 20% ERROR ON MOST READINGS

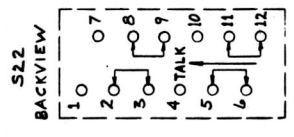
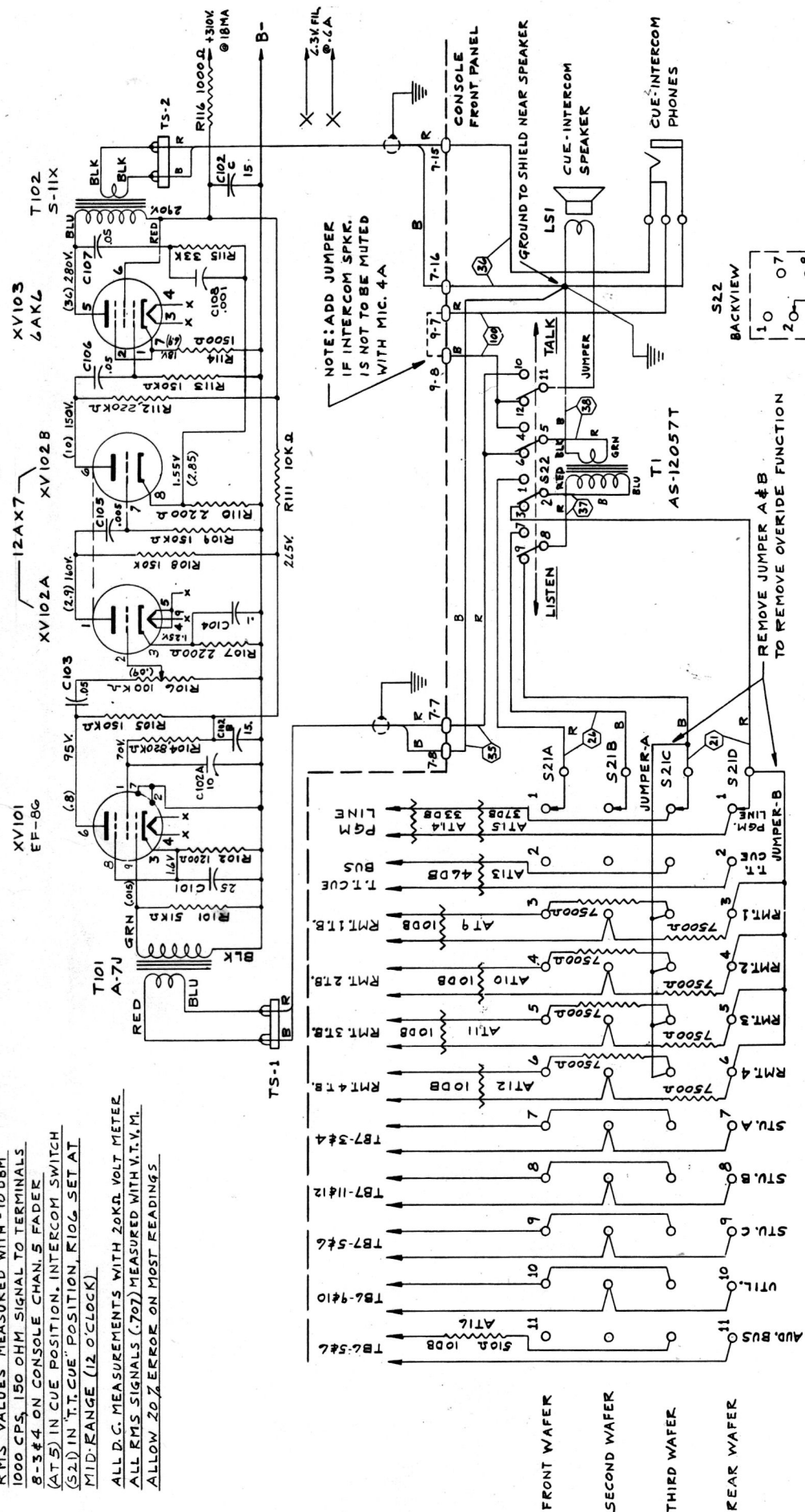

4 POLE-11 POSITION ROTARY SWITCH

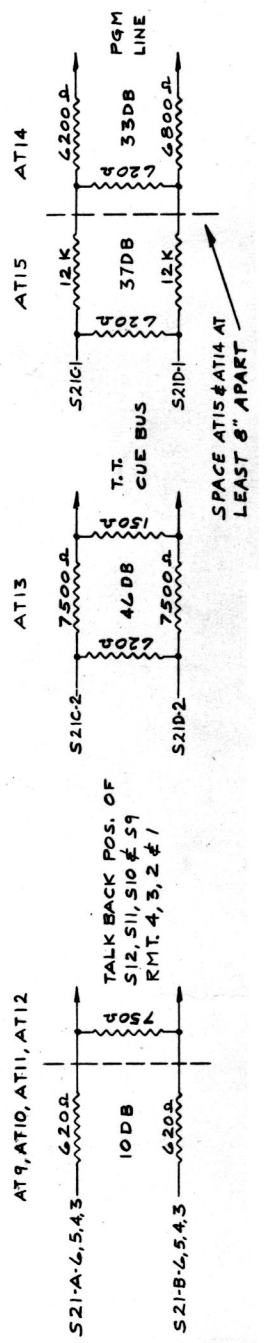

○ WIRE NUMBERS

NOTE: R4A & R4B (EXTERNAL CONTROL)

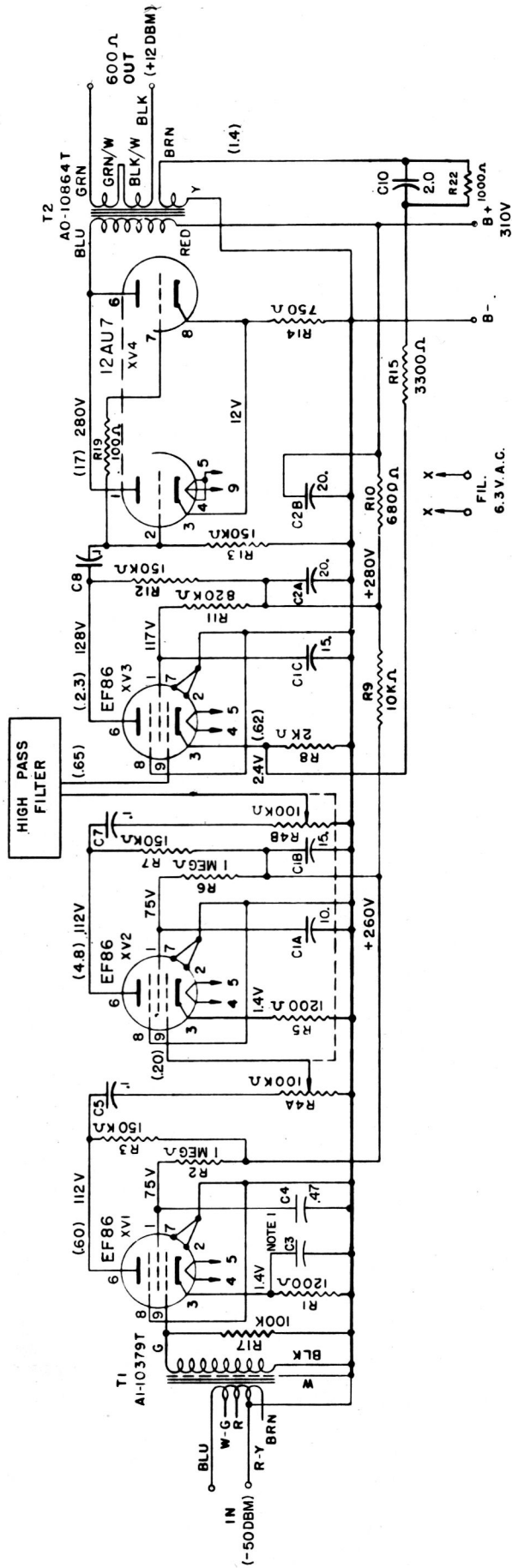

RMS VOLTAGES MEASURED WITH -10DBM AT 1K INTO T.T.3 INPUT (FADER SET AT 8) WITH OUTPUT ADJUSTED TO +12DBM OUTPUT (+8DBM TO LINE).

NOTE F: M-5133B USE .015 MFD. M-5236B USE .005 MFD.

ALL D.C. MEASUREMENTS WITH 20K OHM VOLT METER ALL R.M.S SIGNALS () MEASURED WITH V.T.Y.M. ALLOW 20% ERROR ON MOST READINGS.

BLOCK DIAGRAM
GATESWAY SPEECH INPUT CONSOLE

— LEGEND —
○ — CONNECTIONS IN CONSOLE
□ — CONNECTIONS ON DECK

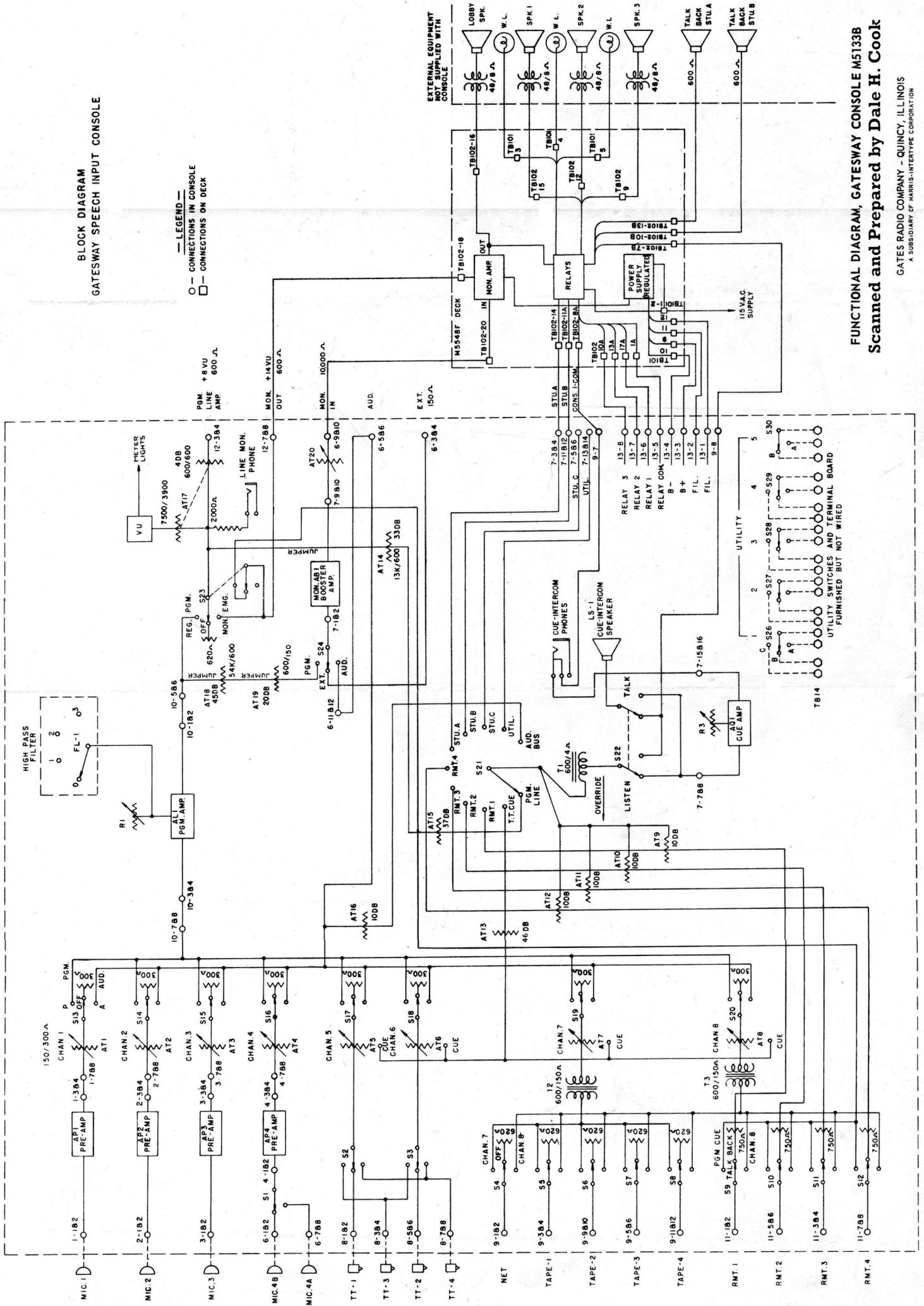

FUNCTIONAL DIAGRAM, GATESWAY CONSOLE M5133B
Scanned and Prepared by Dale H. Cook

GATES RADIO COMPANY - QUINCY, ILLINOIS
A SUBSIDIARY OF HARRIS-INTERTECH CORPORATION

M5215A PRINTED CHASSIS PREAMPLIFIER

INSTRUCTIONS

Gates' M5215A Printed Chassis Preamplifier was developed primarily for use in the new line of consoles. However, where the output levels permit, it may be used for an isolation amplifier or booster amplifier as well as a microphone preamplifier. Its small size and excellent electrical characteristics are due, to a great extent, to the use of the printed chassis wiring employed.

The schematic diagram, 826 8205 001 shows the circuit and external connections. It is a two stage amplifier, using a pentode connected EF86 tube in the first stage and a triode connected EF86 tube in the second stage. Negative feedback is taken from the plate of the second stage back to the cathode of the first stage. This compensates for differences in tube characteristics, reduces distortion and noise. The triode connected stage is shunt fed into the output transformer to allow small size and best operation of the transformer. The amplifier is connected 150 ohms in and out, in the factory. The schematic diagram shows the possible changes in impedances.

SPECIFICATIONS

GAIN: 40 db, +1 db @ 1000 cycles.
RESPONSE: +.5, -1.5 db from 30 to 15,000 cycles.
DISTORTION: .5% or less from 50 to 15,000 cycles @
-6 dbm output.
1% or less from 50 to 15,000 cycles
@ +4 dbm output.
NOISE: 90 to 95 db below +10 dbm output, or
a relative input noise of -120 to -125
dbm.
TUBES: Two EF86.
POWER: +275 to +310 volts DC @ 5 ma., 6.3 volts
AC @ 0.3 amps.
SIZE: 3-5/8" high, 4-5/8" long and 2-3/8" wide.
WEIGHT: 10 ounces.
INPUT IMPEDANCE: 30/50 - 150/250 ohms.
OUTPUT IMPEDANCE: 150/250 - 500/600 ohms.

SOCKET VOLTAGES

V1:	pin 3	1.2 v.	V2:	pin 3	2.8 v.
	pin 1	46 v.		pin 1	125 v.
	pin 6	95 v.		pin 6	125 v.

All measurements taken with a 20,000 ohm per volt meter. Use Simpson Model 260 or equivalent. Allow 20% variation in most readings.

M5215A PRINTED CHASSIS PREAMPLIFIER

PARTS LIST

Symbol No.	Gates Part No.	Description
C1	506 0028 000	Capacitor, .1 uf., 400 V.
C2,C3	506 0027 000	Capacitor, .47 uf., 400 V.
C4	506 0029 000	Capacitor, 1 uf., 200 V.
C5A/B	524 0101 000	Capacitor, 30-30 uf., 350-350 V.
C6	500 0759 000	Capacitor, 100 uuf., 500 V.
R1	540 0490 000	Resistor, 68K ohms, 1 W., 10%
R2	540 0470 000	Resistor, 1500 ohms, 1 W., 10%
R3	540 0503 000	Resistor, 820K ohms, 1 W., 10%
R4	540 0494 000	Resistor, 150K ohms, 1 W., 10%
R5	540 0493 000	Resistor, 120K ohms, 1 W., 10%
R6	540 0329 000	Resistor, 750 ohms, 1 W., 5%
R7	540 0758 000	Resistor, 33K ohms, 2 W., 10%
R8	540 0481 000	Resistor, 12K ohms, 1 W., 10%
R9	540 0068 000	Resistor, 6200 ohms, 1/2 W., 5%
T1	478 0145 000	Input Transformer, A1-10426
T2	478 0118 000	Output Transformer, A0-10427
V1,V2	370 0144 000	Tube, EF86
XV1,XV2	404 0059 000	Socket

ORDERING REPLACEMENT PARTS

When ordering a replacement component, please refer to the parts list. Identify the component by its symbol number and if possible its Gates' part number. The type of equipment in which the part is used is also necessary. This procedure will insure the customer receiving the correct component and at the earliest possible date.

