

BROADCAST EQUIPMENT

INSTRUCTIONS

RCA Consolelette

Type 76-B2

(MI-11613-B)

Type 76-B4

(MI-11613-C)

Power Supply

(MI-11301-B)

RADIO CORPORATION OF AMERICA
RCA VICTOR DIVISION CAMDEN, N. J.

Table of Contents

	Page		Page
Part I—Installation			
Technical Data	iii	Override Switch	16
Description	1	Emergency Program Channel	16
Associated Equipment	2	Emergency "B" Supply	17
Microphones	2	Relay Operation	17
Microphone Stands	2	Speaker Relay Interlock	17
Transcription Turntables	2	Light Relay Interlock	17
Recorders	2	Speaker Relay Interlock (Two or Three Studio Operation)	19
Recording Amplifiers	2	Light Relay Interlock (Two or Three Studio Operation)	19
Loudspeakers	2	Speaker Relay Interlock (Single Studio Operation)	20
Signal Lights and Relays	4	Light Relay Interlock (Single Studio Operation)	20
Power Supply	4	Suggested Operating Procedure	20
Conduit Terminating Box	4	To Place a Program on the Air	20
6 db Pad for Telephone Lines	4	To Audition Studio B while Studio A is on the Air	21
BR-84 Rack or MI-11500 Wall Box	4	To Cue Studio B from Studio A and then place Studio B on the Air	21
Radiotrons	4	To Cue Studio B from a Cue Line and then place Studio B on the Air	21
Wall and Floor Outlets	4	To Talk Back to Studio A or Studio B	21
Locating and Connecting Equipment	7	Announcing	21
Connections to 76-B2 and 76-B4 Consolettes	7	Emergency Use of Monitor Amplifier	21
Audio Input Connections	8	Network Monitoring	21
Audio Output Connections	8		
Connecting Associated Equipment	9	Part III—MI-11301-B Power Supply	
Addition of Signal Lights	9	Technical Data	25
Studio "On Air" and "On Audition" Signal Lights	9	Description	25
Control Room On Air Relay	10	Installation	26
Announce Booth Speaker and Signal Light Relays	10	Mounting	26
Console Signal Lights	10	Connections	26
Instantaneous Recorder	10	Loudspeaker Field Supply	26
Conduit List for Types 76-B2 and 76-B4 Consolettes	11	Emergency Switch	26
		Hum Adjustment	27
Part II—Operation			
General	15	Part IV—Maintenance	
Program Channel	15	Inspection and Checking	31
Audition Channel	16	Care of Pushbutton Switches	32
a. Monitoring	16	Care of Key Switches	32
b. Auditioning	16	Voltage Measurements	32
c. Cueing	16	Replacement Parts	33
d. Talk-Back	16	List of Parts	33
Remote Line Cue and Phone	16		
a. Cue	16		
b. Phone	16		

List of Illustrations

	Page
Figure 1—Type 76-B2 Console with Door Open.....	1
Figure 2—Type 76-B2 Console with Chassis Raised.....	3
Figure 3—6 db Pad for Telephone Lines.....	4
Figure 4—Suggested Recording Setups.....	5
Figure 5—Front Panel Layout.....	5
Figure 6—Relay Mounting Cabinet.....	6
Figure 7—Installation Diagram.....	6
Figure 8—Mounting Dimensions.....	7
Figure 9—Schematic of VU Meter and Pad.....	8
Figure 10—Loudspeaker Connections.....	9
Figure 11—Typical Conduit Layout.....	13
Figure 12—Simplified Block Diagram of Types 76-B2 and 76-B4 Consoles.....	14
Figure 13—Announce Booth Relay Connections.....	17
Figure 14—Simplified Schematic of Control Circuits.....	18
Figure 15—Simplified Block Diagram of Types 76-B2 and 76-B4 Consoles.....	22
Figure 16—Schematic Diagram (W-131973).....	23
Figure 17—MI-11301-B Power Supply.....	25
Figure 18—Mounting Dimensions (MI-11301-B Power Supply).....	26
Figure 19—Interior View of Power Supply.....	27
Figure 20—Wiring Diagram (MI-11301-B Power Supply).....	28
Figure 21—Schematic Diagram (MI-11301-B Power Supply).....	29
Figure 22—Rear View of Power Supply Chassis.....	30
Figure 23—Relay Mounting Plate Wiring.....	33
Figure 24—Line Transformer Wiring.....	34
Figure 25—Preamplifier Mounting Plate Wiring.....	35
Figure 26—Program Amplifier Mounting Plate Wiring.....	36
Figure 27—Monitor Amplifier Mounting Plate Wiring.....	37
Figure 28—Front Panel Wiring (W-131969).....	39
Figure 29—Overall Wiring Diagram (W-131681).....	41

TECHNICAL DATA

Power Required

One MI-11301-B Power Supply or a-c, d-c supply as follows:

a. D-C Plate Supply

Term.	Volts	Milliamperes
116	375	62.0
115	210	1.2
114	278	5.1
104	285	42.0
105	220	4.6
Reg.	245	16.0
106		
Emerg.	200	13.0

b. A-C Filament Supply

Term.	Volts	Milliamperes
112 and 113	6.2	2.7
109 and 110	6.2	1.6
107 and 108	6.2	0.3
101 and 102	6.2	2.4

c. D-C Relay Supply

Term.	Volts	Milliamperes
117 and 118	60	100

Gain

- a. Microphone Input to Line Output: 112 ± 2 db
- b. Transcription Input to Line Output: $81 \pm 1\frac{1}{2}$ db
- c. Line Input to Line Output: $54 \pm 1\frac{1}{2}$ db
- d. Microphone Input to Monitor Output: 110 ± 2 db
- e. Line Input to Monitor Output: 54 ± 2 db
- f. Transcription Input to Monitor Output: 80 ± 2 db
- g. Cue Input to Monitor Output: 34 ± 2 db
- h. Talk-back Input to Monitor Output: 95 ± 2 db
- i. Line Output to Monitor Output: 33 ± 2 db
- j. Microphone Input to Emergency Line Output: 91 ± 2 db
- k. Remote Line through Override: $27 \pm 2\frac{1}{2}$ db
- l. External Record: 90 ± 2 db
- m. Remote Talk-back: 77 ± 2 db

Line Output Level

Normal: +18 dbm** with 0.5% rms harmonic distortion from 50 to 7,500 cycles

Maximum: +26 dbm** with 1% rms harmonic distortion from 50 to 7,500 cycles

Radiotrons*

- 11 RCA-1620 or 11 RCA-6J7†
- 2 RCA-1621 or 2 RCA-6F6†
- 2 RCA-1622 or 2 RCA-6L6†

†May be used when maximum uniformity of characteristics, and minimum of microphonics, hum, and distortion are not required.

Inputs

- a. Six 30- or 250-ohm microphone inputs (balanced)
- b. Six line inputs, 150, 300, and 600 ohms (balanced)
- c. Two 250-ohm transcription inputs (unbalanced)
- d. One 250-ohm talk-back microphone input (balanced)
- e. Five 20,000-ohm monitor cue lines (balanced)

Outputs

- a. One 500- to 600-ohm line
- b. Three 15-ohm monitor lines
- c. One high-impedance headphone output (2,000 to 5,000 ohms)

Line Output Noise Level

Microphone Input at -50 dbm, to Line Output at 18 dbm** output (68 db system gain): -68 db
Microphone Input to Monitor Output at 4 watts (+36 dbm**) output (86 db system gain): -68 db

Distortion

- a. Microphone Input to Line Output: 0.5% rms harmonic distortion from 50 to 7,500 cycles, with normal output of +18 dbm**
- b. Microphone Input to Monitor Output: 1½% rms harmonic distortion from 50 to 7,500 cycles at 4 watts output

Frequency Response

- a. Microphone Input to Line Output: ± 2.0 db from 30 to 15,000 cycles
- b. Microphone Input to Monitor Output: ± 2 db from 30 to 15,000 cycles (audition channel)

Monitor Power Output

- a. 4.0 watts (+36 dbm**) with 1½% rms harmonic distortion from 50 to 7,500 cycles
- b. 8.0 watts (+39 dbm**) with 3% rms harmonic distortion from 50 to 7,500 cycles

Physical Specifications

Width	39 inches
Depth	17 inches
Height	10½ inches
Weight	135 pounds

*TRADEMARK "RADIOTRON" REG. U. S. PAT. OFF. BY RADIO CORPORATION OF AMERICA.

**dbm = decibel level referred to one milliwatt sine wave power.

TYPES 76-B2 AND 76-B4 RCA CONSOLETTES

PART I
Installation**DESCRIPTION**

The Type 76-B2 (MI-11613-B) and Type 76-B4 (MI-11613-C) Consolettes have been designed for use in Broadcast Audio installations to provide a complete and flexible control system in one conveniently arranged unit. All the controls necessary for switching and mixing the audio outputs of microphones, transcription turntables and remote

lines, as well as for auditioning and monitoring, are contained in a single cabinet. The Consolette may be used as a complete control system for a small station, or to control a single studio in larger installations.

The Consolette consists of a metal cabinet containing four pre-amplifiers, a program amplifier, an eight-watt monitoring amplifier, two line transformers and three loudspeaker relays. A VU meter,

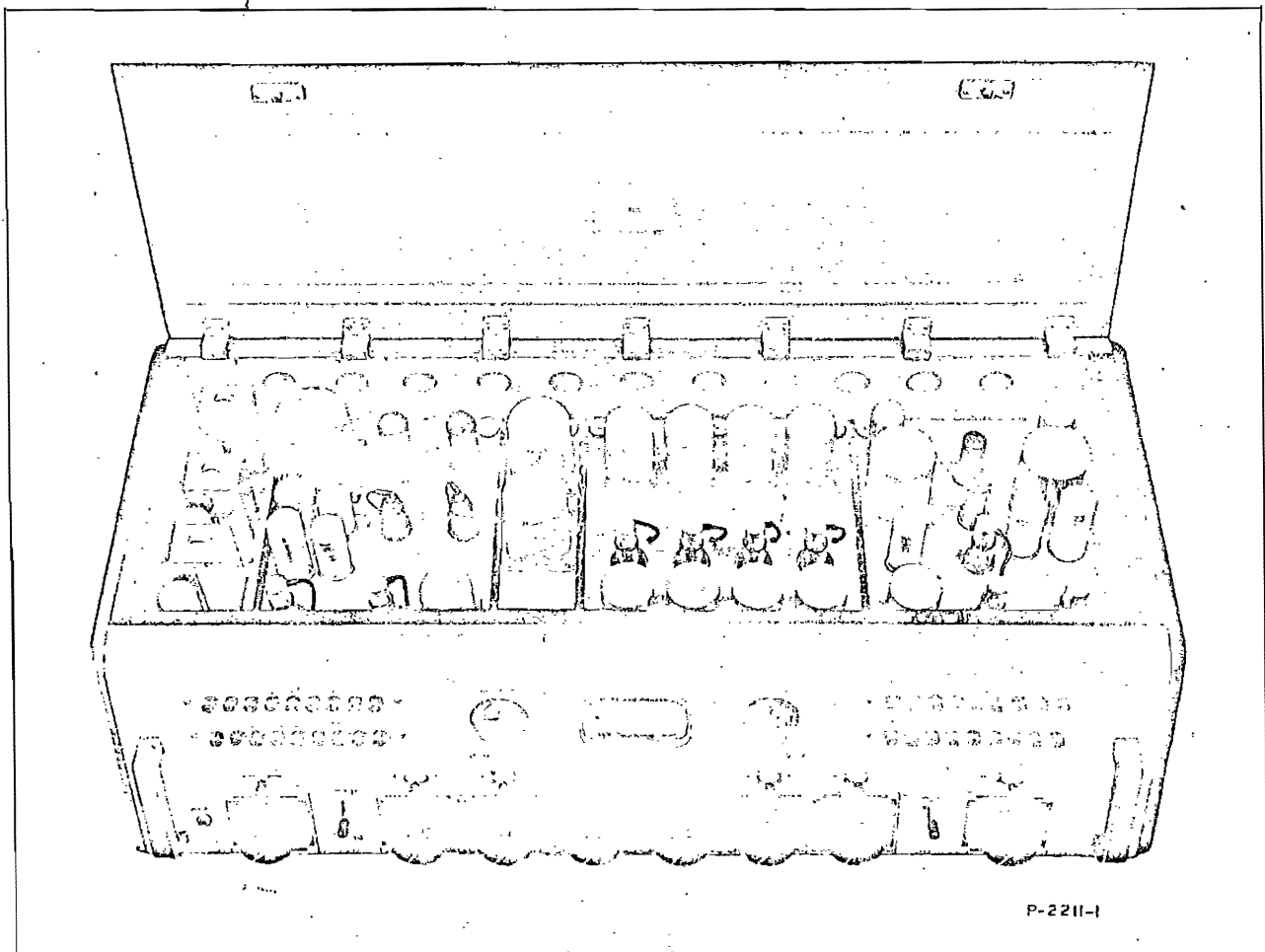

Figure 1—Type 76-B2 Consolette with Door Open

attenuator controls, switches, and other controls are mounted on a slanting front panel. An arrangement of switches makes it possible to use the VU meter to check the condition of the tubes in the program channel.

The 76-B2 and 76-B4 Consolettes are similar in performance and operation and the instructions for installation and operation apply to both types unless otherwise specified.

The top of the Consolette may be opened to inspect and service the Radiotrons and relays or the entire upper section, which is hinged at the back, may be lifted to expose the terminal boards and the bottoms of the mounting plates. As may be seen in figure 2, three terminal boards are provided for external connections. These are mounted on the bottom section of the chassis and are accessible when the upper section is lifted. The terminal boards are arranged so that the low-level audio terminals are separated from the high-level audio terminals and the power leads.

Five rubber-cushioned mounting plates are located on the hinged upper chassis as follows (left to right):

a. Relay Mounting Plate, on which are mounted three relays and their associated equipment. Two terminal boards, on which connections are made to change over from two- (or three-) studio operation to single-studio operation are mounted under this plate.

b. Monitor Amplifier Mounting Plate, on which are mounted the components of the monitor amplifier and the monitor amplifier booster stage.

c. Line Transformer Mounting Plate, on which are mounted the two line transformers and associated resistors.

d. Preamplifier Mounting Plate, on which are mounted the four preamplifiers.

e. Program Amplifier Mounting Plate, on which are mounted the components of the program amplifier and the program amplifier booster stage.

ASSOCIATED EQUIPMENT

The additional apparatus required for operating this equipment will be determined partly by the particular installation, depending on the number of studios and their arrangement. The installation described in this book is designed to fulfill, as completely as possible, the average requirements of the type of broadcasting station for which the Consolette is designed. These instructions will also

serve as a guide to the customer whose installation is not exactly as described in these pages.

The associated equipment described below, or its equivalent, will be required for a complete installation.

Microphones

The Consolette is normally used with two microphones in each of two studios, a fifth microphone (for announcing) in the control room, and if desired, a sixth for an announce or transcription booth. Terminals 9 and 10 and 47 and 48 may be connected in parallel if the same microphone is used for control room announcing and talk-back. The RCA 44-BX, 74-B, MI-6203-B or 77-D ribbon-type microphones are recommended for program pickup, the RCA Type 88-A Pressure Microphone for control room announcing, and the RCA MI-6226 Aerodynamic Microphone and MI-6227 Table Stand for the talk-back circuit.

Microphone Stands

The quality and type of stands required will depend on the number and type of microphones used. The most suitable program-type floor stand for use with all the above mentioned microphones is the RCA Type 90-A. Lower priced stands such as the KS-1A and MI-4068-D are also available.

The Type 91-A Announce Type Desk Stand (MI-4058-C) should be used with the 44-BX microphone only, and the 91-B Desk Stand (MI-4092-C) with the other microphones.

Transcription Turntables

The RCA 70-C2 Transcription Turntables are recommended for the transcription booth or control room installations. They may be used with the Type 72-D or 72-DX Recording Attachment.

Recorders

If the highest quality recording equipment is desired, the 73-A or 73-B Deluxe Recorder is recommended. Suggested recording setups and connection information are shown in figure 4.

Recording Amplifiers

The Type BA-4B or 82-C1 Recording Amplifiers are recommended for driving either the 70-C2 Transcription Turntables, when used with the recording attachment, or the 73-A and 73-B recorders. (See figure 4).

Loudspeakers

The RCA Type LC-1A loudspeakers should be used in the control room, lobby, studios, and

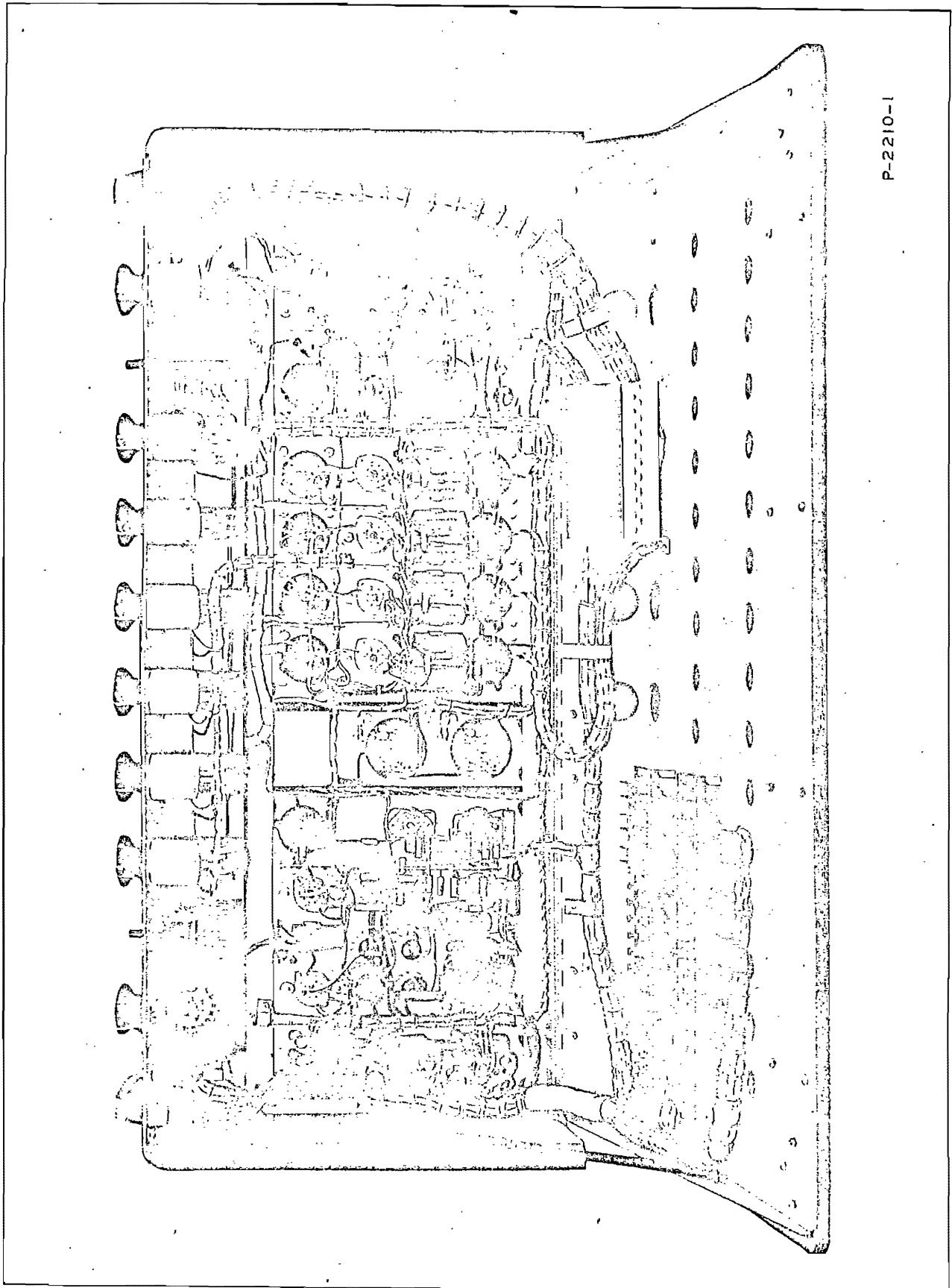

P-2210-1

Figure 2—Type 76-B2 Consolette with Chassis Raised

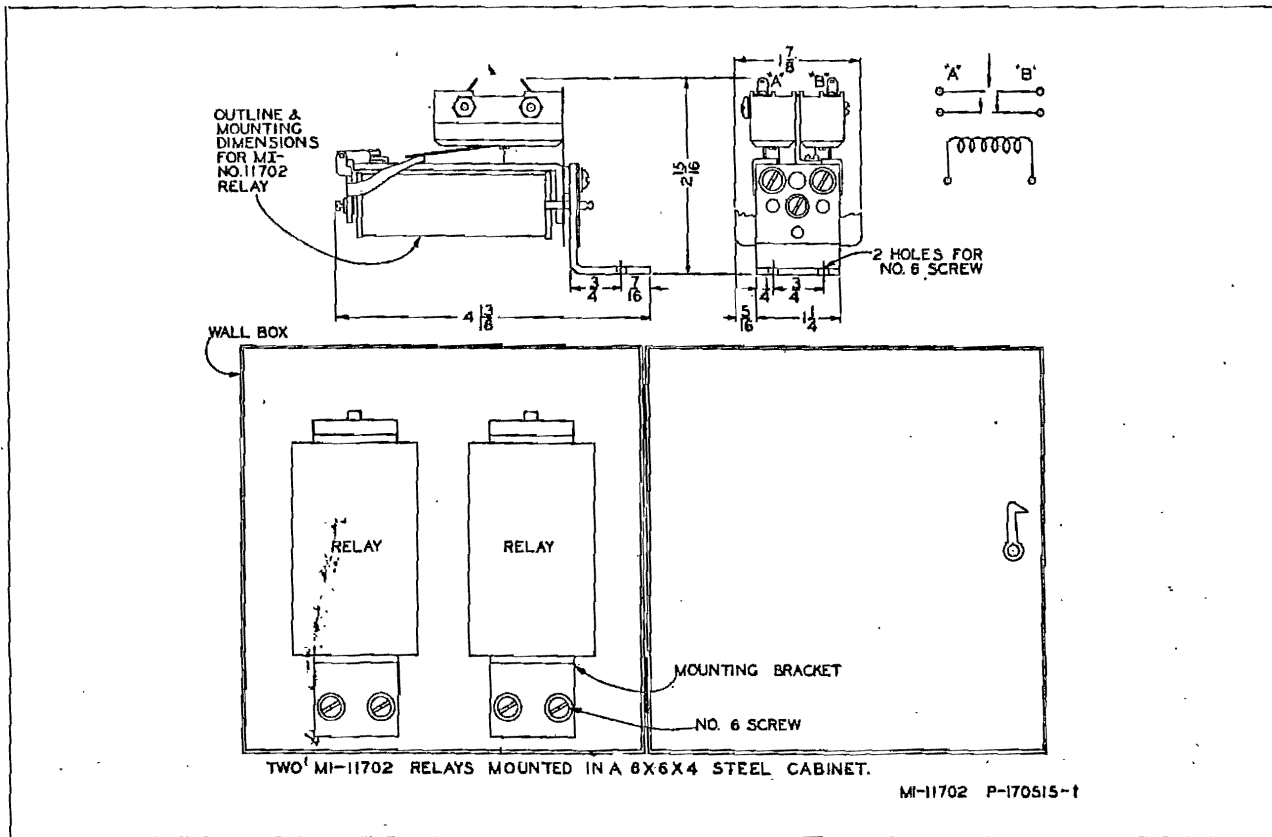

Figure 6—Relay Mounting Cabinet

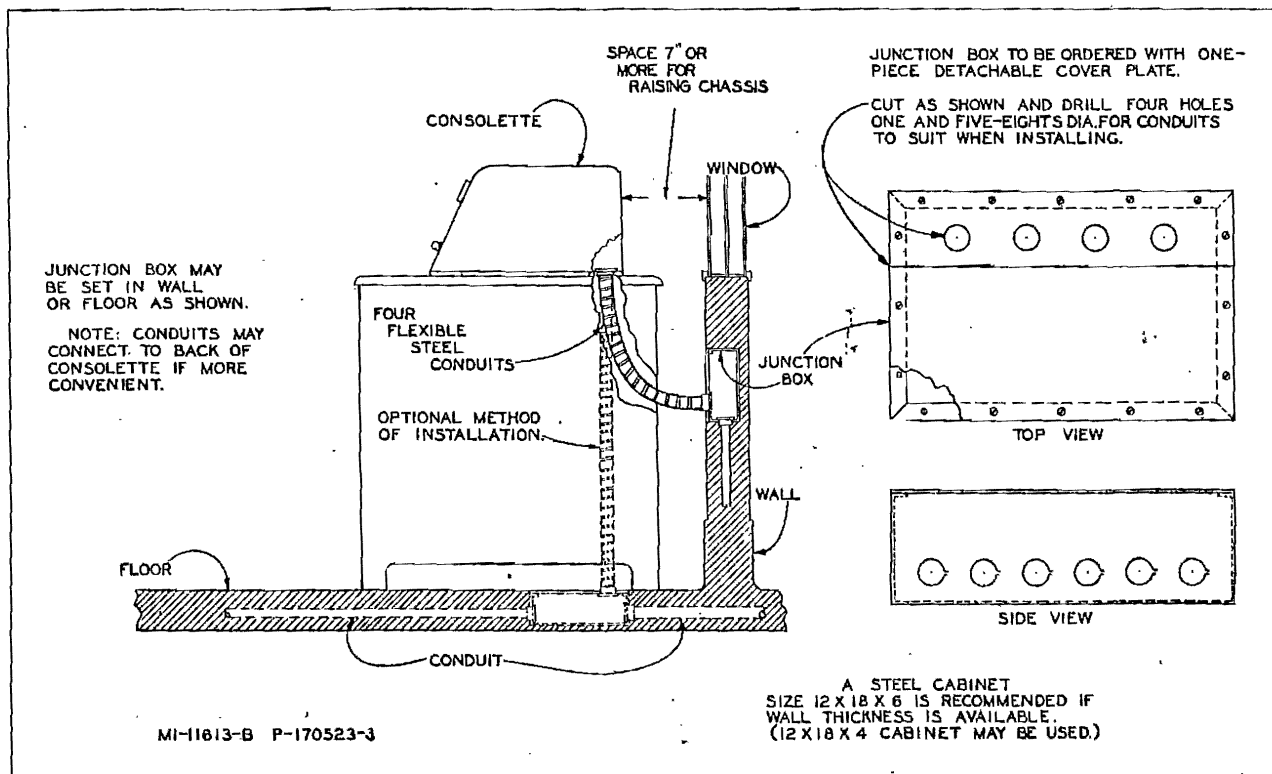

Figure 7—Installation Diagram

LOCATING AND CONNECTING EQUIPMENT

Because of the flexibility of the Consolette and its associated equipment, suggestions only can be offered in respect to arrangement and location of the different units. A suggested layout is shown in figure 11 "Typical Conduit Layout". The Consolette, the MI-11301-B Power Supply, the talk-back microphone, and the monitoring loudspeaker are usually located in a control room between the studios. Glass windows between the control room and studios are provided so the control operator can observe the action in the studios. The transcription turntables are usually located in the announce and transcription booth, but in certain cases may be in the control room. The Consolette is mounted on a desk or table, the power supply being mounted on the wall of the room. The exact location and arrangement of the equipment will depend upon the architectural layout of the station and other considerations of this nature.

Connections to 76-B2 and 76-B4 Consolettes

All external wiring is connected to the three terminal boards which are mounted in the base of

the Consolette. These are accessible when the chassis is lifted. The audio terminal board, at the right and rear of the base, has solder-type terminals. The two power terminal blocks, with solder and screw-type terminals, are at the left of the base. All wiring is brought in through four 1¼ inch flexible conduits. Four 1⅝ inch-diameter holes are provided in the back of the Consolette and there are four similar holes in the base making it possible to attach the conduits at either place. The conduits extend to a conduit terminating box in the wall (or floor) which also has four 1⅝ inch holes to which the conduits are terminated. Conduits from the other units of the installation are terminated at this box and the leads pulled through to the Consolette. Details of the conduit terminating box and the method of installing it and the Consolette are given in figures 7 and 8.

IMPORTANT: Shielded leads should not be cut at the conduit terminating box. They should be pulled through to the Consolette in a continuous piece.

Connection information is provided by the "Conduit List" on page 11. This table lists the conduit sizes, number and type of leads, and the conduits in which they run as well as the terminals

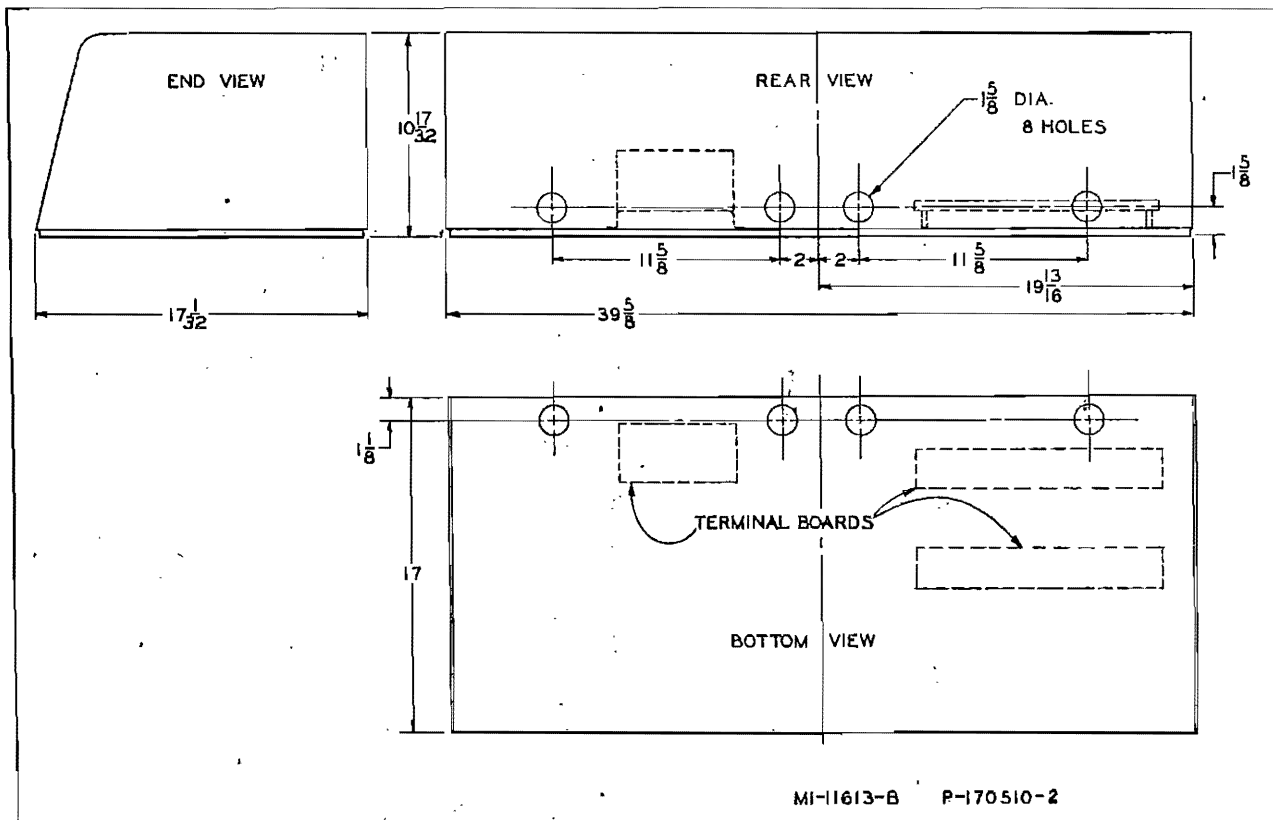

Figure 8—Mounting Dimensions

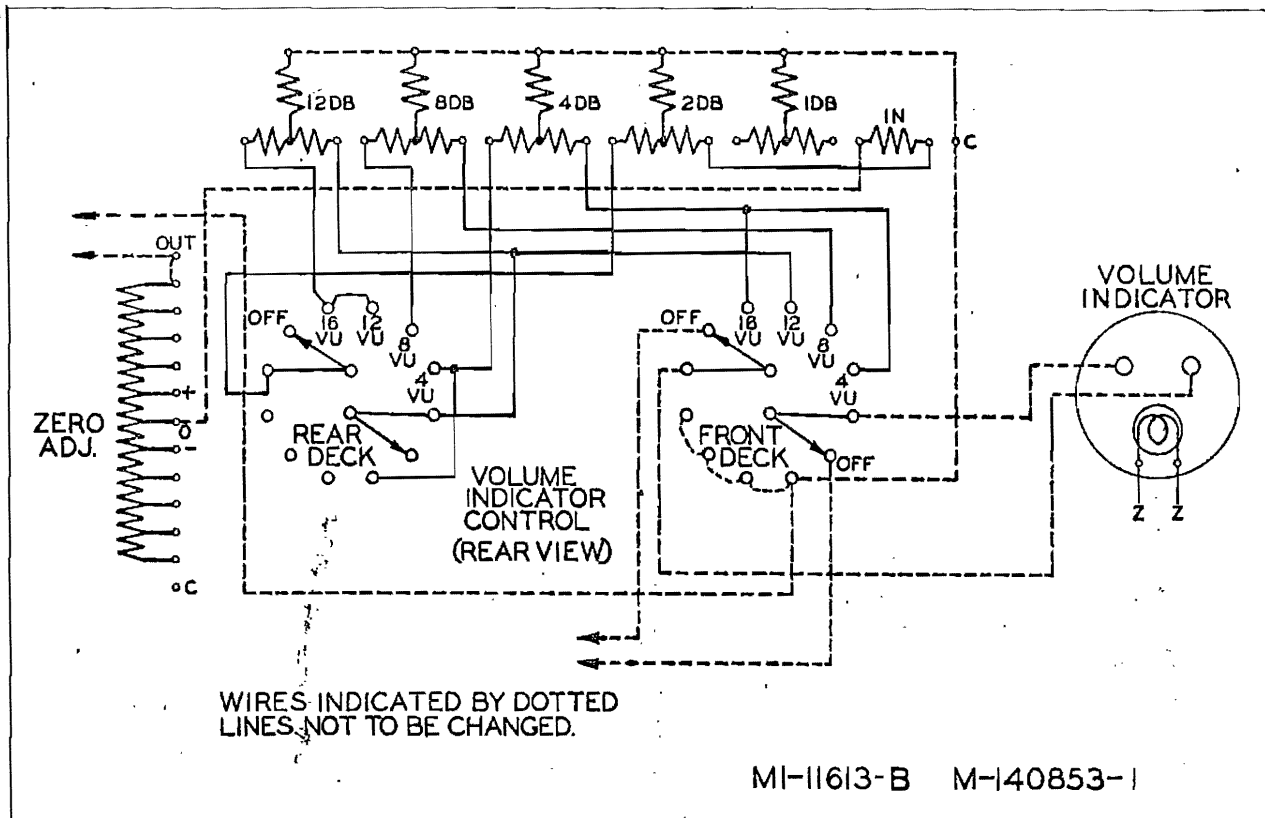

Figure 9—Schematic of VU Meter and Pad

to which leads are connected. For example: conduit number 2 runs from the power line box to terminals number 21 and 22 of the MI-11301-B Power Supply. One pair of 600-volt stranded, shielded, twisted leads is required. This conduit contains the a-c supply circuit and $\frac{1}{2}$ inch conduit is used.

When attaching conduits, care should be taken to avoid damaging the shielded cables of the Console. If necessary, the clamps may be loosened and the shielded cables moved slightly when the fittings of the conduits are added. The clamps should then be replaced.

When shipped from the factory the Console is connected for two-studio operation. It may be connected for single-studio operation by changing the terminal board connections as shown in figure 10 and figure 14.

Audio Input Connections

The audio input terminals of the Console are connected at the factory for microphone input impedances of 250 ohms. Should it be desired to use 30-ohm microphones, the input connections must be disconnected from the 250-ohm primary terminals of transformers T-1, T-2, T-3, and T-4

(terminals 1 and 6) and connected to the 30-ohm primary terminals (2 and 5).

As indicated in the "Schematic Diagram" figure 15, terminals 1, 3, 5, and 7 of the input should be connected to similar terminals of RCA microphones for proper phasing.

Line transformer T-9 and T-10 for Mixer No. 5 and Mixer No. 6, respectively, are connected at the factory for input impedances of 600 ohms. However, the frequency response of many types of remote lines can be improved (with or without equalizers) by operating them into 150 ohms. This can be done by connecting the line transformers (T-9 and T-10) for 150 ohms at their primaries as follows:

- a. Remove the ground wire and the jumper between terminals 3-A and 1-B on both transformers.
- b. Connect 3-A to 3-B and 1-A to 1-B on both transformers.

Audio Output Connections

The LINE OUT terminals of the Console are designed to operate into a 500- to 600-ohm telephone line. When used with some types of tele-

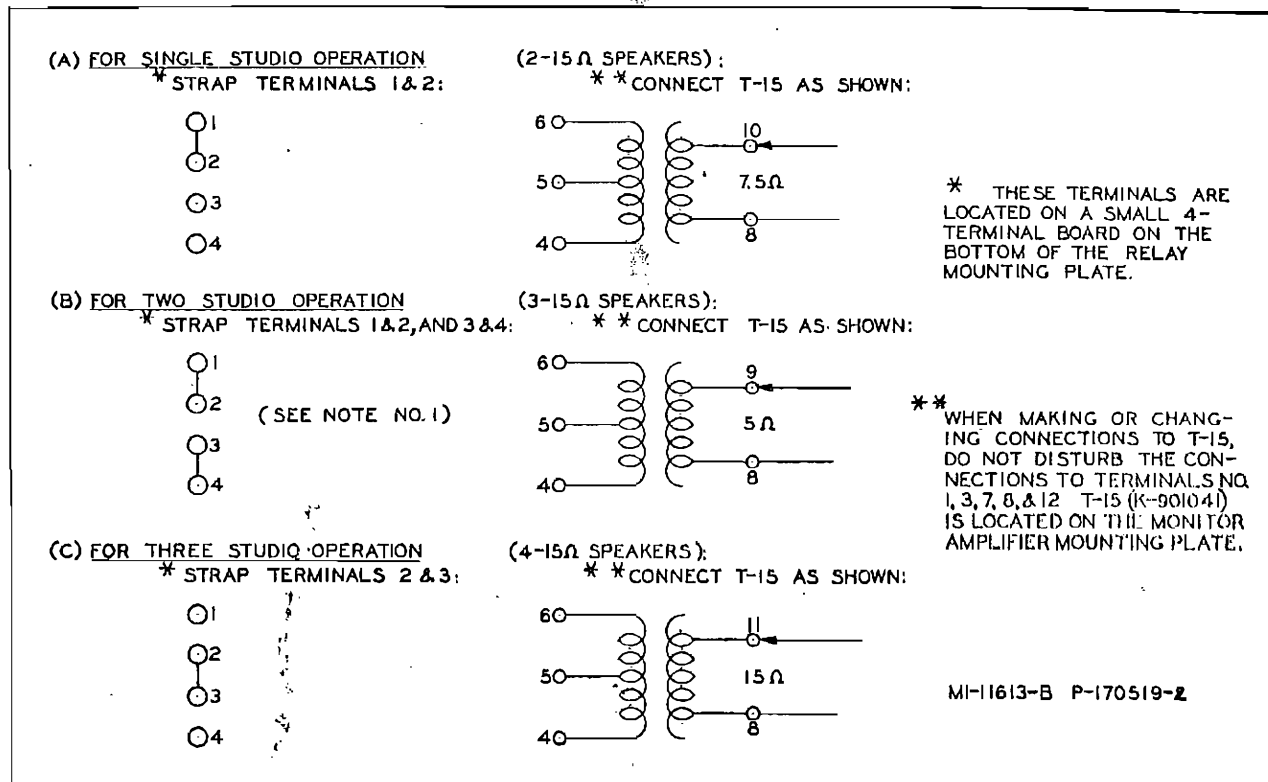

Figure 10—Loudspeaker Connections

phone lines it is advantageous to insert a 6-db pad between terminals 79 and 80 and the telephone line. See the instructions for this under *Associated Equipment*.

Connecting Associated Equipment

A complete suggested layout of the Consolette and associated equipment is illustrated in figure 11, *Typical Conduit Layout*. Arrangement of the conduits is shown in this figure and the leads which run in the conduits and the terminals to which they are connected are shown in the *Conduit List* table. Note that all conduits are arranged so that a-c power leads and audio leads are not run in the same conduit and that low-level audio leads are not run in the same conduit with high-level audio or loudspeaker field supply leads. Any variations on the illustrated setup should be arranged to conform with this practice.

Power for one, two, or three 100-volt, 1,000-ohm, 10-watt loudspeaker fields may be obtained from the MI-11301-B Power Supply. The instructions given in this book under *Power Supply* should be carefully followed. If speakers which have different field voltage and power ratings are used a separate field voltage power supply unit must be provided.

ADDITION OF SIGNAL LIGHTS

When installing signal lights in the two studios, the relays may be connected directly to the terminals provided on the Consolette to obtain d-c energizing voltage. Connections for Studio, Control Room, and Announce Booth light relays are described below.

Studio "On Air" and "On Audition" Signal Lights

The following equipment is required to install signal lamps in the two studios:

- Four MI-11702 Relays and Capacitors.
- Two mounting boxes (See figure 6).
- Studio light equipment (See *Signal Lights and Relays* under *Associated Equipment*).

The MI-11702 Relays are supplied with 0.5 mf capacitors but these are not required for the studio light relays since proper filtering for this circuit is provided within the Consolette.

The relays should be mounted in metal boxes of the type specified in figure 6, which also shows mounting dimensions.

Mount the boxes near their respective studios and make connections as follows:

CONNECTION TABLE

Terminal No.	Relay Connection
124	Common terminal for studio "A" "On Air" and "On Audition" relays
125	Studio "A" "On Air" relay
123	Studio "A" "On Audition" relay
127	Common terminal for studio "B" "On Air" and "On Audition" relays
126	Studio "B" "On Air" relay
128	Studio "B" "On Audition" relay

Connect the a-c supply to the signal lights through the open contacts of the MI-11702 Relays so that the lights will be on when the relays are energized.

Control Room On Air Relay

If the control room "On Air" light is to be used, the following equipment will be required in addition to that listed above:

- One MI-11702 Relay and Capacitor.
- One mounting box (see figure 6).
- One resistor, 180 ohms, 20 watts; RCA Stock number 17666.
- One "On Air" light. (See *Signal Lights and Relays* under *Associated Equipment*).

The relay should be mounted in a metal box as specified in figure 6 and installed near the control room. Conduits for the control room signal lights are shown in figure 11. Relay energizing voltage is supplied by the voltage drop across the 180-ohm, 20-watt resistor which is connected in series with the high side of the relay supply circuit of the MI-11301-B Power Supply (see figure 14). Connections should be made as follows:

- Connect the high side of the relay supply circuit from the MI-11301-B Power Supply to terminal number 122 instead of 118 on the Consolelette.
- Connect terminal 118 to terminal 121.
- Connect the 180-ohm, 20-watt resistor and 0.5 mf capacitor across the control room "On Air" relay.
- Connect the control room "On Air" relay to terminals 121 and 122 on the Consolelette.
- Connect the a-c supply of the Control Room "On Air" light through the open terminals of the MI-11702 relay (marked "A" in fig. 6) so that the light will be on when the relay is on.

Announce Booth Speaker and Signal Light Relays

The Consolelette has control terminals for the Announce Booth speaker and "On Air" Signal light relays but does not have terminals to supply d-c

energizing voltage for them. These relays may be installed and energizing power obtained as described below. The following equipment will be required:

- One MI-11702 Relay and Capacitor.
- One MI-11703 Relay and Capacitor.
- One Mounting Box (see figure 6).
- Two 180-ohm, 20-watt resistors. (RCA stock No. 17666).
- Suitable light equipment.

To obtain energizing voltage, the relays are connected in series with the high side of the relay supply circuit from the MI-11301-B Power Supply. The circuit may be connected as shown in figure 13 if the Announce Booth relays only are to be used. If this circuit is used in conjunction with the Control Room light relay as shown in figure 14, connect terminal 76 to terminal 122 in addition to the connections described under *Control Room "On Air" Relay* and connect the Announce Booth relays in series between terminal 18 of the MI-11301-B Power Supply and terminal 122 of the Consolelette as shown in figure 14.

The 0.5 mf capacitors and the 15-ohm, 5-watt resistors are included with the relay kits. Note that the Consolelette must be connected for three-studio operation before these relays are installed. See figure 13 for connections.

Console Signal Lights

Two plug buttons (one at either side of the meter) are inserted in the front panel of the Consolelette and wiring is provided to permit the addition of two signal lamp jacks. When these are used, signal lights such as "Pre-Set" and "On Air" can be operated from the master control room when the Consolelette is used in large studio installations.

Terminals 67, 68, 69, and 70 may be used for external connections to the signal lamp jacks.

The following equipment is recommended:

- 2 lamp jacks, RCA stock no. 26562.
- 2 lamps, RCA stock no. 21332.
- 1 lamp cap, green, RCA stock no. 17931.
- 1 lamp cap, red, RCA stock no. 17930.

INSTANTANEOUS RECORDER

The RCA Type 72-C or 72-D Instantaneous Recorder, or the 73-B Deluxe Recorder may be used with the Type 76-B2 or 76-B4 Consolelette for recording auditions, broadcasts, or other material. Terminals 41 and 42, which must be bridged, are

provided for the recording connection. Two suggested recording setups are illustrated in figure 4. The following equipment will be required for the setup shown in figure 4-A:

- a. Four 120-ohm (stock no. 30189) resistors.
- b. One Type BA-2A Booster Amplifier.
- c. One Type BA-4A Monitoring Amplifier (MI-11223) with volume control.

d. One suitable Recorder.

The following equipment is required for the setup shown in figure 4-B.

- a. Two 120-ohm resistors (RCA stock no. 30189).
- b. One Type BA-4A Monitoring Amplifier.
- c. One suitable Recorder.

CONDUIT LIST FOR TYPES 76-B2 AND 76-B4 CONSOLETTES

Note No. 1: The following list of conduits refer to the typical conduit layout illustrated in figure 11. Numbers refer to conduits in the figure.

Note No. 2: Terminal numbers in bold face type refer to terminals on the MI-11301-B Power Supply.

Note No. 3: Asterisks (*) indicate optional equipment shown in dotted lines in figure 11.

Note No. 4: Wires in conduits are indicated as follows:

- A. MI-64 (No. 20 AWG stranded, 300-volt, shielded, twisted, pair).
- B. MI-65 (No. 16 AWG stranded, 600-volt, shielded, twisted, pair).
- C. Pair No. 14 lead covered.

Conduit No.	Size	From	To	Wire	Circuit	Terminals
1	1/2	Power Box	MI-11702 Relays	1-C	A-C Supply	A-C
2	1/2	Power Box	MI-11301-B Power Supply	1-C	A-C Supply	21 and 22
3	1/2	Power Box	TT-1	1-C	A-C Supply	A-C of TT-1
4	1/2	Power Box	TT-2	1-C	A-C Supply	A-C of TT-2
5*	1/2	Power Box	MI-11702 Relays	1-C	A-C Supply	A-C
6*	1/2	Power Box	MI-11702 Relay	1-C	A-C Supply	A-C
7*	1/2	Power Box	TT-1 (booth)	1-C	A-C Supply	A-C
8*	1/2	MI-11702 Relay	"On Air" Light Studio A	1-C	A-C	A-C
9*	1/2	MI-11702 Relay	"Audition" Light Studio A	1-C	A-C	A-C
10	1/2	Consolette	Cue Speaker Studio A	1-B	Speaker Field	19 and one side of studio B speaker field
				1-C	Speaker Audio	133 and 134
11*	1/2	Consolette	Light Relays Studio A	2-A	D-C to Relays	124 and 125 "On Air" 123 and 124 "Audition"
12	1/2	Consolette	Microphones Studio A	2-A	Microphone	1 and 2, 3 and 4
13	1/2	Microphone 1 Studio A	Microphone 2 Studio A	1-A	Microphone	
14	1 1/4	MI-11301-B Power Supply	Conduit Box	1-B	Speaker Fields	19 and 20 1 to 101 2 to 102 7 to 107 8 to 108 9 to 109 10 to 110 12 to 112 13 to 113
				4-B		17 to 117 18 to 118 15 to 115 16 to 116 4 to 104 5 to 105 6 to 106 11 to 111 3 to 103 14 to 114
15	1 1/4	MI-11301-B	Conduit Box	1-B	Relay	17 to 117 18 to 118 15 to 115 16 to 116 4 to 104 5 to 105 6 to 106 11 to 111 3 to 103 14 to 114
				4-B	Plate Supply	5 to 105 6 to 106 11 to 111 3 to 103 14 to 114

CONDUIT LIST (CONT'D)

Conduit No.	Size	From	To	Wire	Circuit	Terminals
16	None	Consolette	Talk-Back Microphone	Cord	1-A	Microphone . . . 47 and 48
17*	1/2	Consolette	Announce Booth Relay	1-B	Audio	135 and 136
				2-A	D-C to Relays	75 and 76
18*	1/2	TT-1 (Booth)	TT-2 (Booth)	1-C	A-C	A-C
19*	1/2	TT-1 (Booth)	TT-2 (Booth)	1-A	Audio	Audio term. of TT
20*	1/2	Consolette	Office Speakers	1-B	Audio	135 and 136
21	1/2	Consolette	TT-1 Audio (Control Room)	1-A	Audio	23 and 24
22	1/4	Consolette	Conduit Box	Include in conduits 22 and 23 all wires from filaments, plates, d-c		
23	1/4	Consolette	Conduit Box	to relays, audio to speakers, and station ground.		
24	1/4	Consolette	Conduit Box	Include in conduits 24 and 25 all wires from microphones, turn-		
25	1/4	Consolette	Conduit Box	tables, remote lines, cue lines, and line out.		
26	1/2	Consolette	TT-2 Audio (Control Room)	1-A	Audio	25 and 26
27*	1/2	Consolette	Line Out	1-A	Audio	79 and 80
28	1/2	Consolette	Control Room Ann. Mic.	1-A	Microphone	9 and 10
29*	1/2	Consolette	Ann. Booth Microphone	1-A	Microphone	11 and 12
30*	1/2	Consolette	Ann. Booth Turntables	2-A	Audio	23 and 24
						25 and 26
						29 and 30
						31 and 32
			Remote Lines	6-A	Remote	33 and 34
						35 and 36
						37 and 38
31*	1/4	Consolette				39 and 40
						53 and 54
						55 and 56
			Cue Lines	5-A	Cue	57 and 58
						59 and 60
						61 and 62
32*	1/2	MI-11702 Booth Relay	MI-11703 Booth Relay	1-A	D-C to Relays	D-C terminals
33*	1/2	Consolette	Studio B Light Relay	2-A	D-C to Relays	126 and 127
						127 and 128
34*	1/2	Studio B Light Relay	Studio B "On Air" Light	1-C	D-C	D-C Term.
35*	1/2	Studio B Light Relay	Studio B "Audition" Light	1-C	A-C	A-C Term. of Lamp
36	1/2	Conduit Box	Studio B	1-B	Audio	131 and 132
		Cue Speaker		1-B	Speaker Field	One side of studio "A" speaker field and one side of monitor speaker field.
37	1/2	Consolette	Monitor Speaker	1-B	Speaker Audio	129 and 130
				1-B	Speaker Field	20 and one side of Studio "B" speaker field.
38	1/2	Consolette	Studio B Microphones	2-A	Microphone	5 and 6
						7 and 8
39	1/2	Microphone 1 Studio B	Microphone 2 Studio B	1-A	Microphone	
40	1/2	Ann. Booth Speaker	MI-11703 Relay	1-B	Audio	
41*	1/2	Ann. Booth "On Air" Lamp	MI-11702 Relay	1-C	A-C	A-C Term. of lamp
42*	1/2	Consolette	Station Ground	1-C	Ground	103
43*	1/2	Consolette	MI-11702 Relay (Cont. Room)	1-A	D-C to Relay	121 and 122
44*	1/2	MI-11702 Relay	"On Air" Lamp (Cont. Room)	1-C	A-C	A-C Term. of lamp
45*	1/2	Power Box	MI-11702 Relay	1-C	A-C Supply	A-C

Figure 17 — Typical Conduit Layout

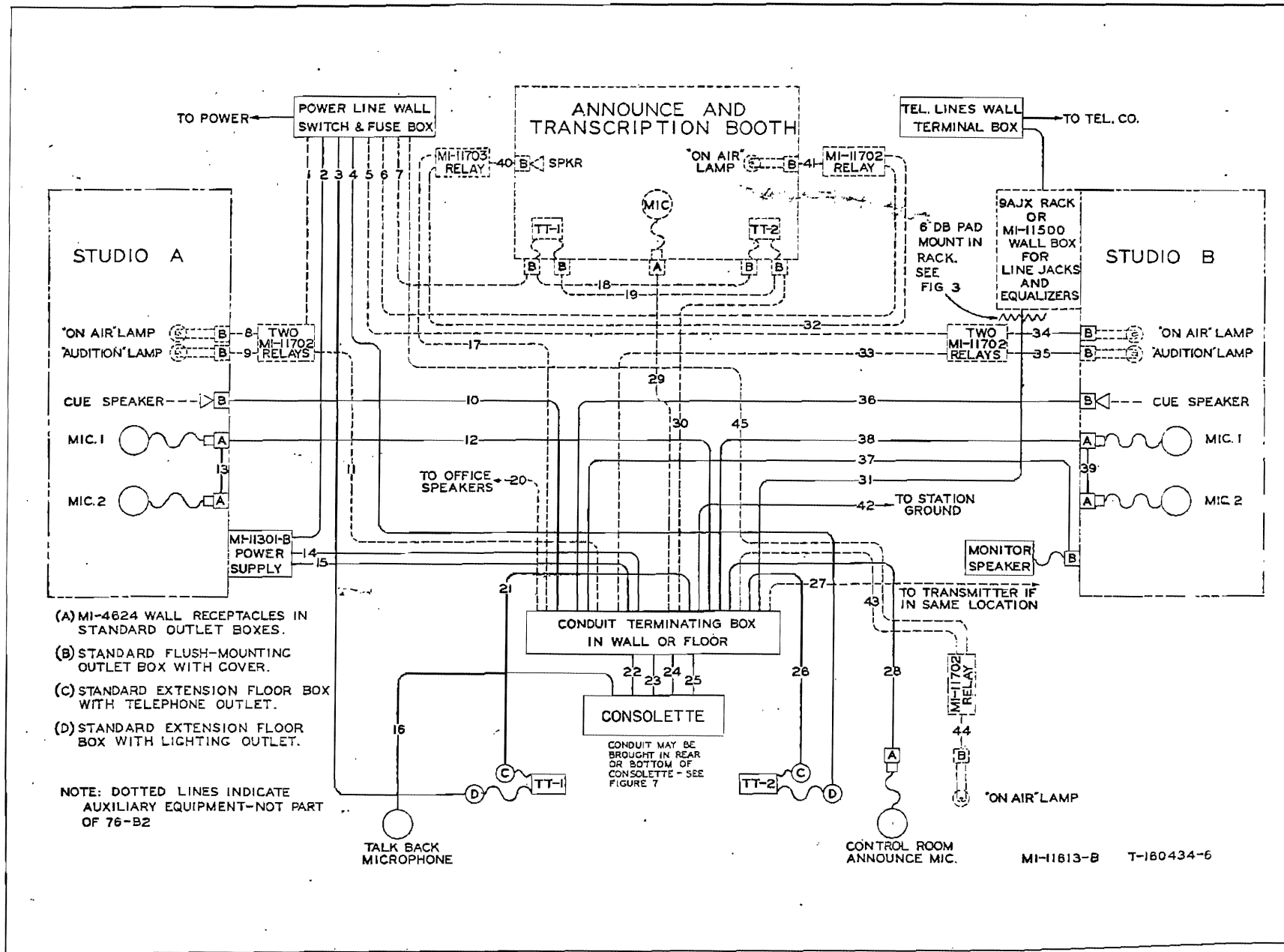
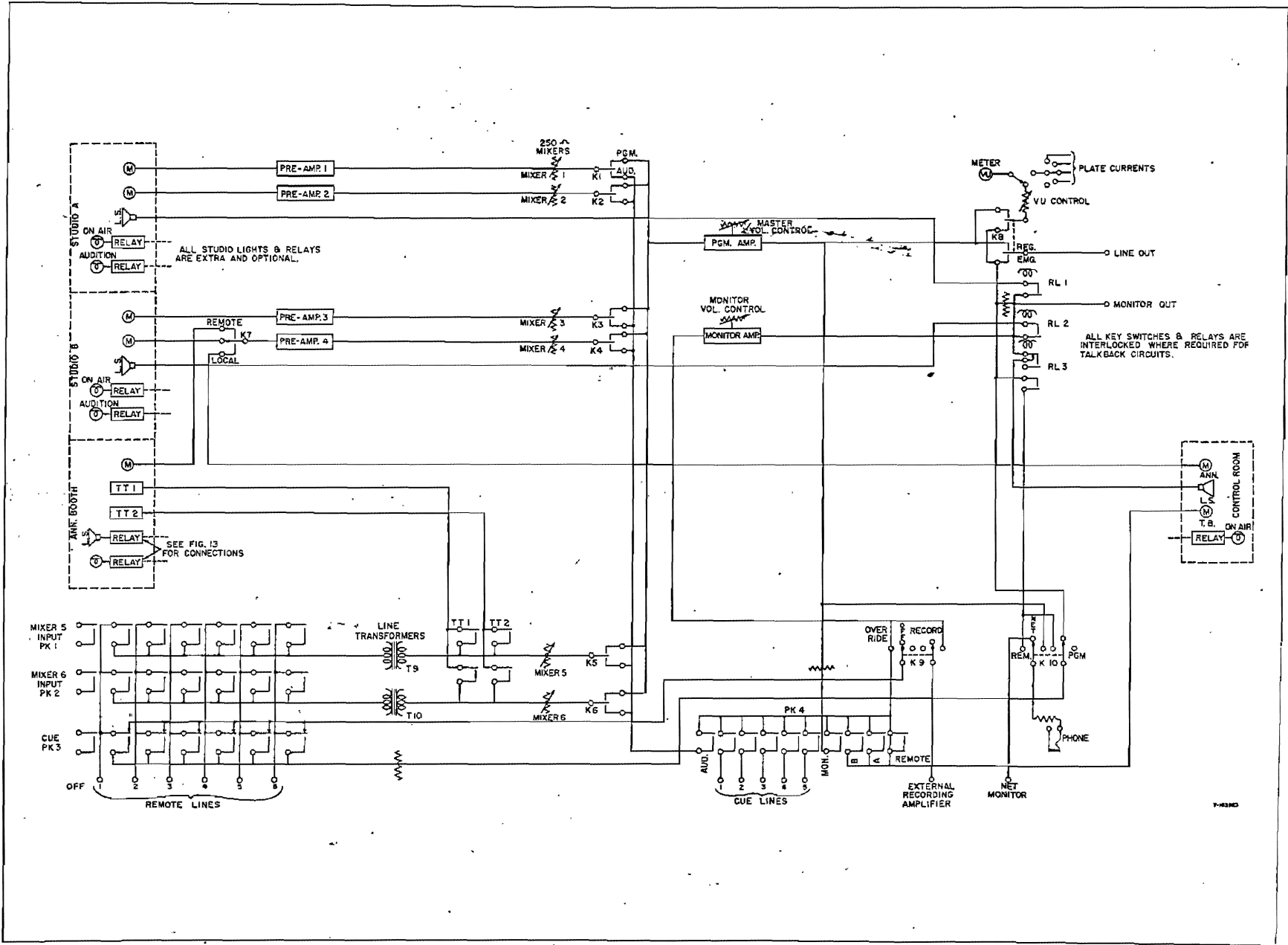

Figure 12—Simplified Block Diagram of Types 76-B2 and 76-B4 Consoles



PART II

Operation

GENERAL

An overall block diagram of the Consolette, showing controls and associated equipment, is shown in figure 12. This diagram represents a typical installation in which the Consolette is used in a small station to control two studios and a transcription booth from a single control room. The equipment can, of course, be used for single studio operation in larger stations.

All the controls are conveniently arranged on the front panel of the Consolette. Figure 5 shows the front panel layout and arrangement of the controls.

Six mixer controls are arranged in a group at the center near the bottom of the panel. The first two of these are associated with the two microphones in studio "A", the third and fourth with the two microphones in studio "B", and the fifth and sixth with two sets of pushkeys which may be used to select any two of six remote lines or two transcription inputs.

Above the six mixer controls are six audition-program switches (K-1 to K-6) which control the input to the program and audition busses. The first four of these control the outputs of the first four mixers which in turn control the output of four microphone preamplifiers for the microphones in studios "A" and "B". A switch (ANNOUNCE REMOTE-LOCAL) on the input of the fourth preamplifier may be used to switch to a fifth microphone in the control room for announcing or a sixth remote microphone at some other point (such as a transcription booth).

Two sets of pushbuttons are mounted in the upper right-hand corner of the panel. These buttons are used in conjunction with the two line transformers to control the input to the last two mixer controls (K-5 and K-6). These transformers and resistor attenuating networks are arranged in such a way that the remote lines and transcription turntables are properly terminated and matched to the

mixing pads. Each set of pushbuttons consists of nine buttons interlocked so that only one can be used at a time. The pushbuttons numbered one to six in each group are connected respectively to six incoming remote lines, those numbered TT-1 and TT-2 to two turntables, and the remaining button is an OFF position.

The two sets of pushbuttons are electrically interlocked, making it impossible to place a single incoming remote signal or a single transcription turntable on both mixers at once. Number 5 mixer and associated pushbuttons have priority over number 6.

The outputs of the six mixers feed through mixing resistors, into six PROGRAM-AUDITION switches. When these switches are in their normal positions, the outputs of the mixers are open while loading resistors are connected across both the program and audition busses.

When a PROGRAM-AUDITION switch is thrown to the PROGRAM position, the output of the corresponding mixer is placed on the program bus. When the switch is thrown to the AUDITION position the signal is placed on the audition bus.

A detailed description of the various channels of the Consolette is given below.

Program Channel

The program bus is connected to the input of the program amplifier which consists of a booster amplifier and a three-stage studio amplifier. The MASTER volume control is connected between the booster amplifier and the studio amplifier.

From the program amplifier, the signal passes to the LINE-OUT switch which controls the output of the Consolette to the out-going line. The LINE-OUT switch has, in addition to its normal (or off) position, a regular and an emergency position (marked REG and EMG). When the switch is in the normal position a load is connected across the

program amplifier output. The volume indicator is connected across this circuit.

When the LINE-OUT switch is in the REGULAR position, the output of the program amplifier is fed into the outgoing line with the load removed and the volume indicator still across the circuit. The function of the LINE-OUT switch when in the EMERGENCY position is explained under *Emergency Program Channel* below.

When the PHONE-MONITOR switch is in the PROGRAM position, the program channel may be monitored by means of the phone jack and headphones.

Audition Channel

The audition channel of the Console is connected to one of a set of pushbuttons which determine the input to the monitor amplifier. These buttons, labeled MONITOR INPUT, are the lower of the two sets of pushbuttons in the upper left-hand corner of the front panel. The MONITOR INPUT pushbuttons permit the following functions to be performed.

a. *Monitoring.* One button (marked MON) connects the input of the monitor amplifier, through proper bridging resistors, across the output of the program amplifier. A program on the air may be monitored in this manner.

b. *Auditioning.* One button (AUD), as mentioned above, connects the output of the audition bus into the monitoring amplifier, making it possible to carry on an audition in one studio while the other studio is on the air.

c. *Cueing.* Five buttons, marked CUE and numbered from 1 to 5, are provided to select any one of five monitoring or cueing lines. These five buttons are mechanically interlocked with the monitor and audition buttons in such a way that only one can be on at a time. Any button, when pressed, releases the button previously depressed.

d. *Talk-back.* Two buttons, marked TB and lettered A and B, are associated with the seven buttons mentioned above but not mechanically interlocked with them. These buttons are used for talk-back into studio A and studio B respectively. Either button, when pressed, connects the talk-back microphone to the input of the monitor amplifier and turns the proper studio speaker on. The speaker interlock is more fully explained below. These buttons, although not mechanically interlocked with the other seven MONITOR INPUT buttons, are electrically interlocked so the

talk-back microphone is connected to the input of the monitor amplifier when either button is pressed. The connection previously made is restored when the button is released.

Remote Line Cue and Phone

The fourth set of interlocked pushbuttons (upper row in the upper right-hand corner of the front panel) are used as follows:

a. *Cue.* The buttons marked CUE and numbered 1 to 6 are connected to the six incoming remote lines. Pressing any of the buttons will connect the output of the monitor amplifier into the corresponding remote line provided the line is not already in use.

b. *Phone.* The phone jack makes it possible to listen to any of the remote lines by placing the PH. MON switch in the REMOTE position. It is possible to talk to any of the remote lines by pressing either of the two pushbuttons (marked TB) associated with the six remote cue buttons. When either of these buttons is pressed, the talk-back microphone is connected to the input of the monitoring amplifier and the output of the monitoring amplifier is connected into the remote lines. In this way a conversation can be carried on with any of the six remote lines by putting the PH. MON switch in the REMOTE position and holding down the remote line talk-back buttons. The two buttons are not mechanically interlocked with the six remote line cue buttons. A ninth button is used for an off position.

Override Switch

When the switch marked OVERRIDE-OFF-RECORD is thrown to the OVERRIDE position, a signal on any of the six remote lines (not in use) will be heard in the monitor speaker.

Emergency Program Channel

If for some reason, the program amplifier of the Console should fail, the monitoring amplifier may be used in the program channel.

When the LINE-OUT switch is thrown to the EMERGENCY position, the outgoing line is connected, through a bridging resistor, to the output of the monitoring amplifier. Thus, by placing the program signal on the audition bus and pressing the AUD button of the MONITOR INPUT the monitor amplifier will feed the outgoing line. The VU meter will also be transferred to the output of the monitor amplifier so that the level can be properly adjusted.

Emergency "B" Supply

An emergency "B" supply for the four pre-amplifiers is also provided for the Consolette. In case of failure of the B+ power, which is normally obtained from the program amplifier rectifier, a switch on the MI-11301-B Power Supply can be thrown to obtain B+ power for the preamplifiers from the monitoring amplifier rectifier. The operation of this switch is more fully explained under *Power Supply* in Part III of this book.

Relay Operation

An interlocking relay system is used in the Consolette to provide the necessary function of controlling the output of the monitoring amplifier to the three speakers, and the supplementary function of controlling the signal light equipment. The speaker relays are a part of the Consolette, while signal-light relays, although not furnished, can easily be connected as described previously.

Speaker Relay Interlock

The Consolette contains three speaker relays, one each for the control room speaker, studio "A" speaker, and studio "B" speaker. The three relays are controlled by the following switches:

- ANNOUNCE switch.
- Four Program-Audition switches (A-P 1, 2, 3, and 4).
- LINE-OUT switch.
- Talk-back buttons of the MONITOR INPUT group.
- Remote talk-back button of remote line pushbuttons.

The sequence of operation is outlined in the chart below. Note that although the control room speaker is normally on, the control room speaker relay is normally off. If the speaker relay power should fail for any reason, the control room speaker will remain on. The two studio speaker relays are on when the speakers are on and off when the speakers are off, so that the studio speakers will remain off if the power supply should fail.

Other on-off combinations can be obtained by operating the above mentioned switches in various combinations but the basic operation is as outlined in the table.

If an announce booth speaker and "On-Air" light are used as shown in figure 12, the speaker relay is controlled by the ANNOUNCE REMOTE-LOCAL switch (K-7). In the 76-B4 Consolette only, the announce booth speaker relay is also controlled by

K-4. The announce booth speaker is on when the relay is off and will remain on if the power fails.

Light Relay Interlock

As noted previously, the Consolette supplies d-c power for four signal-light relays. The control room and announce booth light relays may be added as described under *Addition of Signal Lights* in Part I.

The Studio "A" and Studio "B" "On Air" and "On Audition" relays are controlled by the following switches:

- Four Program-Audition switches (A-P 1, 2, 3, and 4).
- Talk-back buttons and audition buttons of the MONITOR INPUT group.
- LINE-OUT switch.
- ANNOUNCE switch.

The sequence of operation is outlined in the table below. Like the loudspeaker relays, other on-off combinations can be obtained by various combinations of switches. However, only one light can be on at one time in a studio. The "On Air" light takes priority over the "On Audition" light.

It will be noted that all desired relay functions are on at the same time, and that no combination of switch positions will place more than three relays on at the same time.

If an announce booth speaker and "On Air" light are used, as shown in figure 13, the light relay is

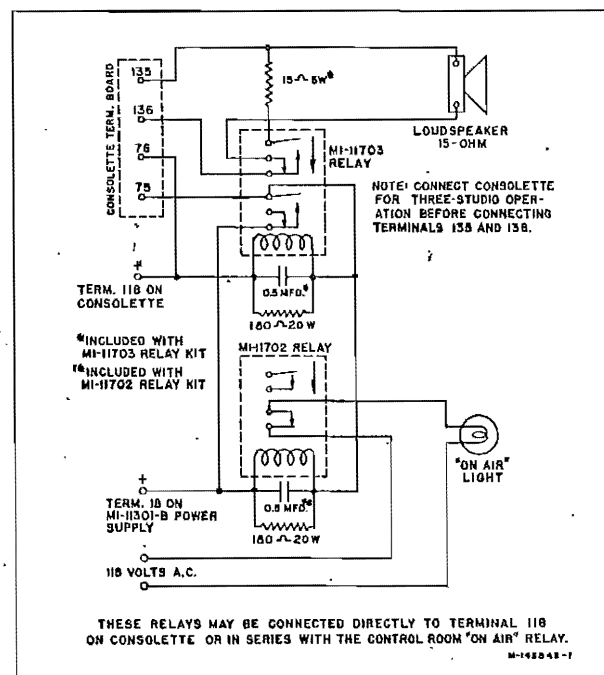

Figure 13—Announce Booth Relay Connections

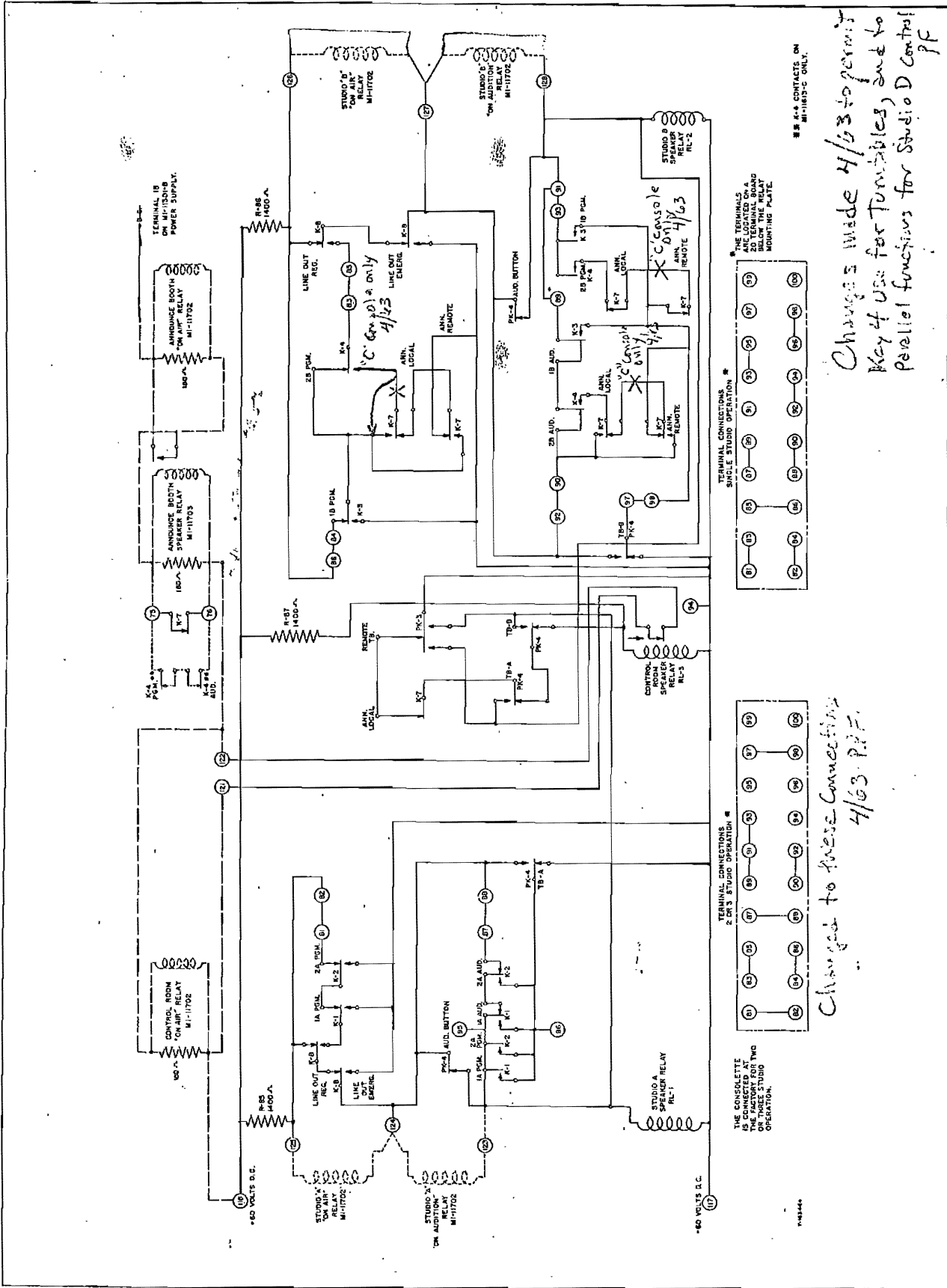

Figure 14—Simplified Schematic of Control Circuits

controlled by the speaker relay, the light being on only when the speaker is off.

In the 76-B2 Consolette, the announcer booth speaker relay is controlled by the ANNOUNCE switch K-7. In the 76-B4 Consolette, the speaker relay is controlled by both K-7 and K-4, the two extra contacts on K-4 being used in conjunction with the announce booth relay control contacts in K-7. The additional contacts and connections are

shown in dotted lines in the Consolette *Schematic Diagram*, figure 16.

When a control room "On Air" light is used, as described under *Control Room On Air Light Relay*, the light relay is operated by the control room speaker relay. The switches which control this relay are listed under *Speaker Relay Interlock* on page 17. The control room "On Air" light is on only when the control room speaker is off.

SPEAKER RELAY INTERLOCK (TWO OR THREE STUDIO OPERATION)

Function	Switching	Studio A Speaker	Studio B Speaker	Control Room Speaker
Normal	Switches normal	on	on	on
Studio A in use	a. K-1 and/or K-2 to P or A	off	on	on
	b. Same as "a" and TB-A pressed	on	off	off
	c. K-1 and/or K-2 to P and K-8 to REG	off	on	on
	d. Same as "c" and TB-A pressed	off	off	off
Studio B in use	a. K-3 and/or K-4 to P or A with K-7 normal	on	off	on
	b. Same as "a" and TB-B pressed	off	on	off
	c. K-3 and/or K-4 to P, K-7 normal, and K-8 REG	on	off	on
	d. Same as "c" and TB-B pressed	off	off	off
Announce Mic. in use	a. K-7 to LOCAL position	on	on	off
	b. K-7 to REMOTE position	on	on	on
	c. K-7 to LOCAL, K-3 off, K-4 on	on	on	off
	d. K-7 to REMOTE, K-3 off, K-4 on	on	on	on
Remote talk-back	Remote TB buttons pressed	off	off	off
Emergency	K-8 to EMG	off	off	on

NOTE: Speaker relays are controlled by the following switches:

Studio A speaker: K-1, K-2, K-8, TB-A button, TB-B button, and REMOTE TB button

Studio B speaker: K-3, K-4, K-7, K-8, TB-A button, TB-B button, and REMOTE TB button

Control Room speaker: K-7, TB-A button, TB-B button, and REMOTE TB button

LIGHT RELAY INTERLOCK (TWO OR THREE-STUDIO OPERATION)

Function	Switching	Studio A		Studio B	
		"On Air"	Audition	"On Air"	Audition
Normal	Switches normal	off	off	off	off
Studio A in use	a. K-1 and/or K-2 to P and K-8 to REG.	on	off	off	off
	b. K-1 and/or K-2 to A and AUD button pressed	off	on	off	off
	c. Same as "b" and TB-A button pressed	off	off	off	off
Studio B in use	a. K-3 and/or K-4 to P, K-7 to normal and K-8 to REG.	off	off	on	off
	b. K-3 and/or K-4 to P, K-7 to either LOCAL or REMOTE, K-8 to REG	off	off	off	off
	c. K-3 and/or K-4 to A, K-7 to normal, and AUD button pressed	off	off	off	on
	d. Same as "c" and TB-B pressed	off	off	off	off
	e. K-3 off and K-4 to A, K-7 either LOCAL or REMOTE and AUD button pressed	off	off	off	off
Emergency	K-8 to EMG	on	off	on	off

NOTE: Light relays are controlled by the following switches:

Studio A "On Air" relay: K-1, K-2, and K-8

Studio A "Audition" relay: K-1, K-2, K-8, AUD button, and TB-A button

Studio B "On Air" relay: K-3, K-4, K-7, and K-8

Studio B "Audition" relay: K-3, K-4, K-7, K-8, AUD button, and TB-B button

SPEAKER RELAY INTERLOCK (SINGLE-STUDIO OPERATION)

Function	Switching	Studio A	
		Speaker	Control Room Speaker
Normal	Switches normal	on	on
Studio A in use	a. K-1 and/or K-2, K-3 or K-4 to P or A, K-7 to normal	off	on
	b. Same as "a" and TB-A pressed	off	on
	c. K-1 and/or K-2, K-3, or K-4 to P, K-7 to normal and K-8 to REG	off	on
	d. Same as "c" and TB-A pressed	off	off
Announce Mic. in use	a. K-7 to LOCAL position b. K-7 to REMOTE position	on on	off on
Remote talk-back	Remote TB buttons Pressed	off	off
Emergency	K-8 to EMG position	off	on

NOTE: Speaker relays are controlled by the following switches:

Studio A speaker: K-1, K-2, K-3, K-4, K-7, K-8, TB-A button, and REMOTE TB button

Control Room speaker: K-7, TB-A button, and REMOTE TB button

LIGHT RELAY INTERLOCK (SINGLE-STUDIO OPERATION)

Function	Switching	Studio A	
		"On Air"	"Audition"
Normal	Switches normal	off	off
Studio A in use	a. K-1 and/or K-2, K-3, K-4, to P, K-7 to normal position, K-8 to REG	on	off
	b. K-4 to P, K-8 to REG and K-7 to either LOCAL or REMOTE	off	off
	c. K-1 and/or K-2, K-3, K-4, to A, K-7 to normal and AUD button pressed	off	on
	d. Same as "c" and TB-A pressed	off	off
	e. K-4 to A, AUD button pressed, and K-7 to either LOCAL or REMOTE	off	off
	f. K-1 and/or K-2, K-3, K-4, to A, AUD button pressed, and K-8 to EMG.	on	off
	g. K-8 to EMG position	on	off

NOTE #1: Light relays are controlled by the following switches:

Studio A "On Air" relay: K-1, K-2, K-3, K-4, K-7, and K-8.

Studio A "Audition" relay: K-1, K-2, K-3, K-4, K-7, K-8, AUD button, and TB-A button.

NOTE #2: K-7 to REMOTE has contacts to control a signal light relay for an announce booth.

SUGGESTED OPERATING PROCEDURE

To Place a Program on the Air

The following procedure may be used to place a program on the air. (Assume that microphone 1 in studio A is to be used.)

a. With all switches in their normal (off) positions, press the proper CUE or MONITOR pushbutton and regulate the MONITOR volume control to obtain the desired volume level from the studio and control room speakers.

b. Throw the microphone switch A-P 1 to the "P" position.

c. Adjust the MASTER attenuator to approximately step 13.

d. Adjust mixer number 1 to determine the proper level setting as indicated by the VU meter. This setting should be approximately step 13 when a signal of normal intensity is being picked up by the microphone. Next return mixer number 1 to "0".

e. Throw the LINE OUT switch to the REG position at the moment the microphone is to go on the air. (The cue signal is removed from the studio speaker when this switch is thrown.) Then adjust the mixer control to the previously determined setting.

f. Press the monitor pushbutton and adjust the monitor volume control as may be necessary.

If any other input is to be used, the above procedure should be followed except that switches and mixers should be operated as follows:

SWITCH AND MIXER TABLE

Input	Switch	Mixer
Mic. 1, studio A	Mic. A-P no. 1 to P	1
Mic. 2, studio A	Mic. A-P no. 2 to P	2
Mic. 1, studio B	Mic. A-P no. 3 to P	3
Mic. 2, studio B	Mic. A-P no. 4 to P and ANN sw. to norm.	4
Remote lines	Mic. A-P no. 5 or 6 to P and, correspond- ing input P-K 1 or P-K 2	5 or 6
Transcription Turntable no. 1	A-P 5 or A-P 6 to P, and TT-1	5 or 6
Transcription Turntable no. 2	A-P 5 or A-P 6 to P, and TT-2	5 or 6

To Audition Studio B while Studio A is on the Air

To audition studio B, while studio A is on the air, proceed as follows:

a. With the talk-back and monitor pushbuttons in the normal (off) positions, press the AUD pushbutton and throw the microphone switch, A-P number 3, to the A position.

b. Adjust mixer number 3 and the monitor volume control to obtain a suitable output from the control room loudspeaker.

To Cue Studio B from Studio A and then place Studio B on the Air

Assuming that microphone number 1 in studio A is in use and it is desired to place microphone number 1 in studio B on the air, it is necessary to perform only the following steps at the moment studio B is to go on the air (since studio B loudspeaker is already receiving the signal from studio A).

a. Close mixer number 1.

b. Throw microphone switch A-P number 3 to the P position.

c. Adjust mixer number 3 to the proper level as indicated by the VU meter.

To Cue Studio B from a Cue Line and then place Studio B on the Air

Assuming that microphone number 1 is in use in studio A and that studio A is on the air, proceed as follows:

a. Press the proper CUE line pushbutton and regulate the Monitor volume control to obtain the desired volume from studio B speaker. The cue line may be monitored by the control room speaker.

b. At the moment studio B is to go on the

air, perform the following operations in quick succession:

(1) Close mixer number 1.

(2) Throw microphone switch A-P number 3 to the P position. (Assuming microphone number 1 in studio B is to go on the air).

(3) Adjust mixer number 3 to the proper level as indicated by the VU meter.

To Talk Back to Studio A or Studio B

To talk back to either studio A or studio B proceed as follows:

Press the talk-back pushbutton A or B according to the studio desired, and talk into the talk-back microphone. This cannot be done when either studio is on the air since the LINE OUT switch interlocks electrically to prevent the studio speaker relay from coming on.

Announcing

When using the 76-B2 Consolette, the announce booth "On Air" lamp will light when K-7 is thrown to the REMOTE position. For this reason, when the announcement is to be made from the remote microphone, it is advisable to first throw K-4 to the PROG position and then operate the ANNOUNCE switch at the instant the announce booth microphone is to go on the air.

Because of the additional contacts on K-4 in the 76-B4 Consolette, the ANNOUNCE switch K-7 may be thrown to REMOTE and then K-4 to PROG when ready for the announcement, since the announce booth "On Air" lamp will remain off until K-4 is closed.

NOTE: When using microphone number 4 (see fig. 12) in studio B, it is possible to throw the ANNOUNCE switch (K-7) and allow studio B to hear the announcement and then be returned to the air.

Emergency Use of Monitor Amplifier

In case of failure of the program amplifier during a broadcast, the monitor amplifier may be used pending repair of the program amplifier in the following manner: Assuming that microphone number 1 is on the air when the trouble occurs, quickly throw A-P switch number 1 to the A position, press the AUD pushbutton, and throw the LINE-OUT switch to the EMG position.

Network Monitoring

When terminals 27 and 28 are connected to the network, or other outside signal; the operator may listen to the signal, by using the headphones, when the PHONE MONITOR switch is in the normal (middle) position.

Figure 15—Simplified Block Diagram of Types 76-B2 and 76-B4 Consoles

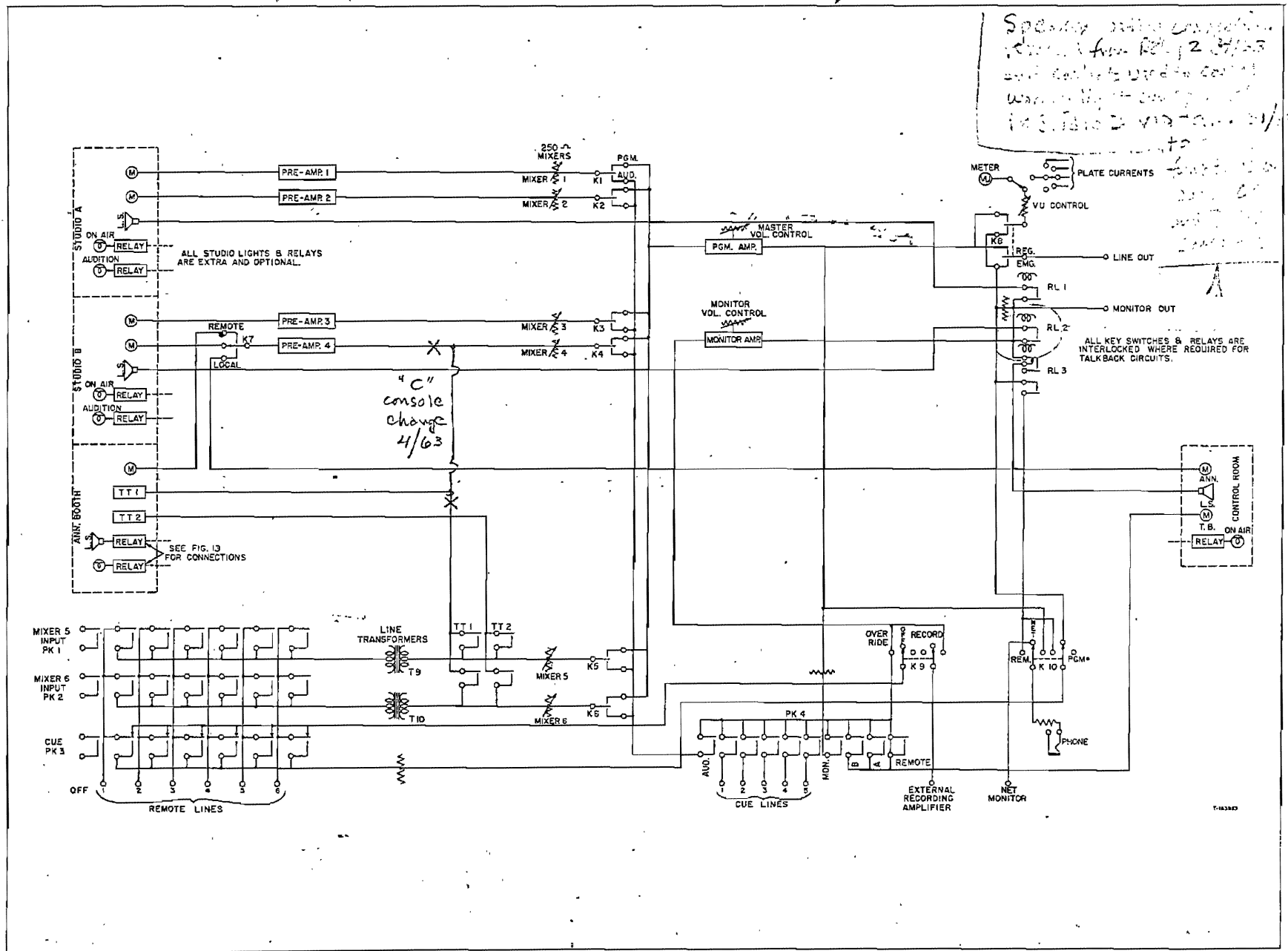

T-1034D

"C" Console Speaker Relay #2
Modifications (4/63)

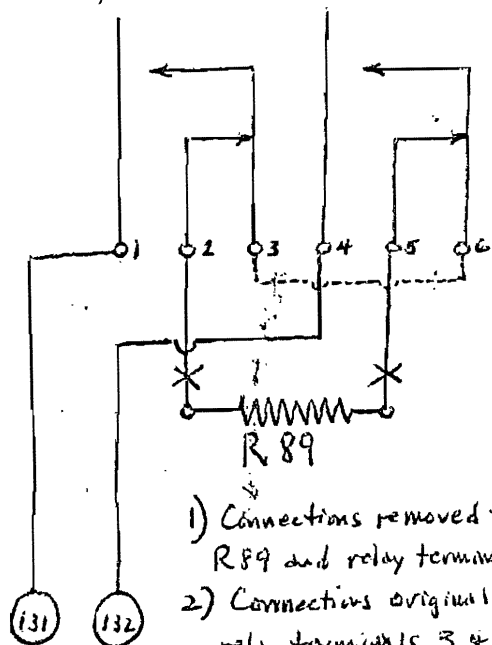

- 1) Connections removed between R89 and relay terminals 2 & 5
- 2) Connections originally on relay terminals 3 & 6 moved to respective ends of R89
- 3) Connection added between relay terminals 3 & 6 (shown above dotted)
- 4) Term. 131 + 132 connected in series with existing Studio D spkr + warning line control line to Rack A.

"C" Console "Local / Remote" Switch
Modifications (4/63)

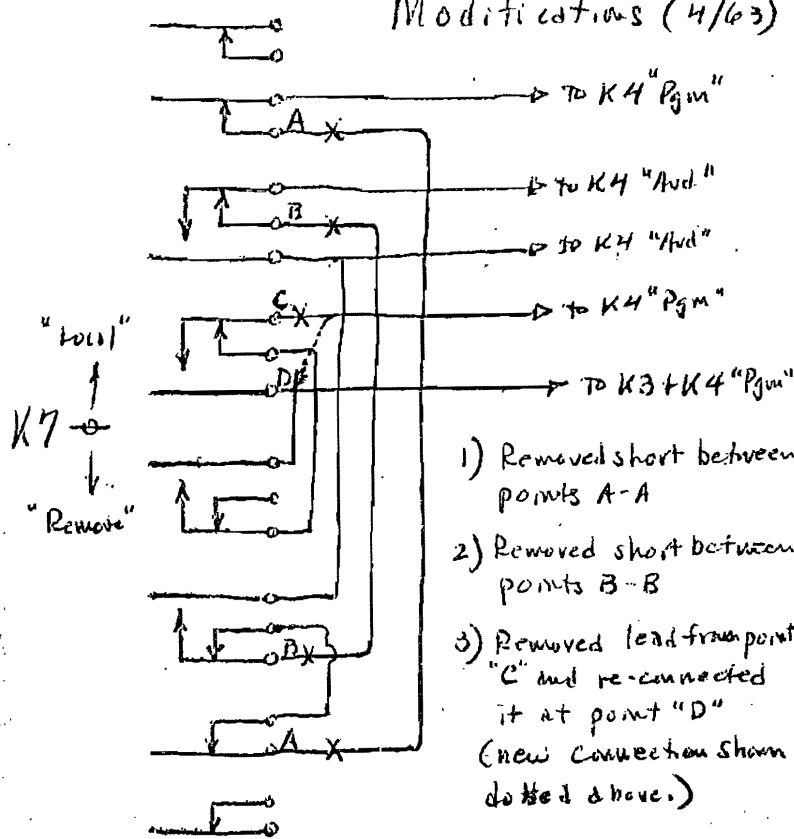

- 1) Removed short between points A-A
- 2) Removed short between points B-B
- 3) Removed lead from point "C" and re-connected it at point "D" (new connection shown dotted above.)

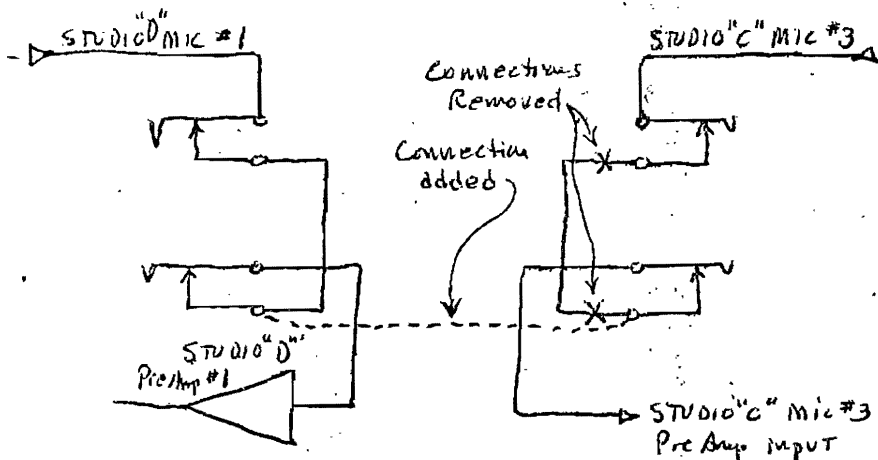

Rack C jack-field changes permitting Studio "D" microphone to appear on both "C" and "D" consoles.

P.F. - 4/63

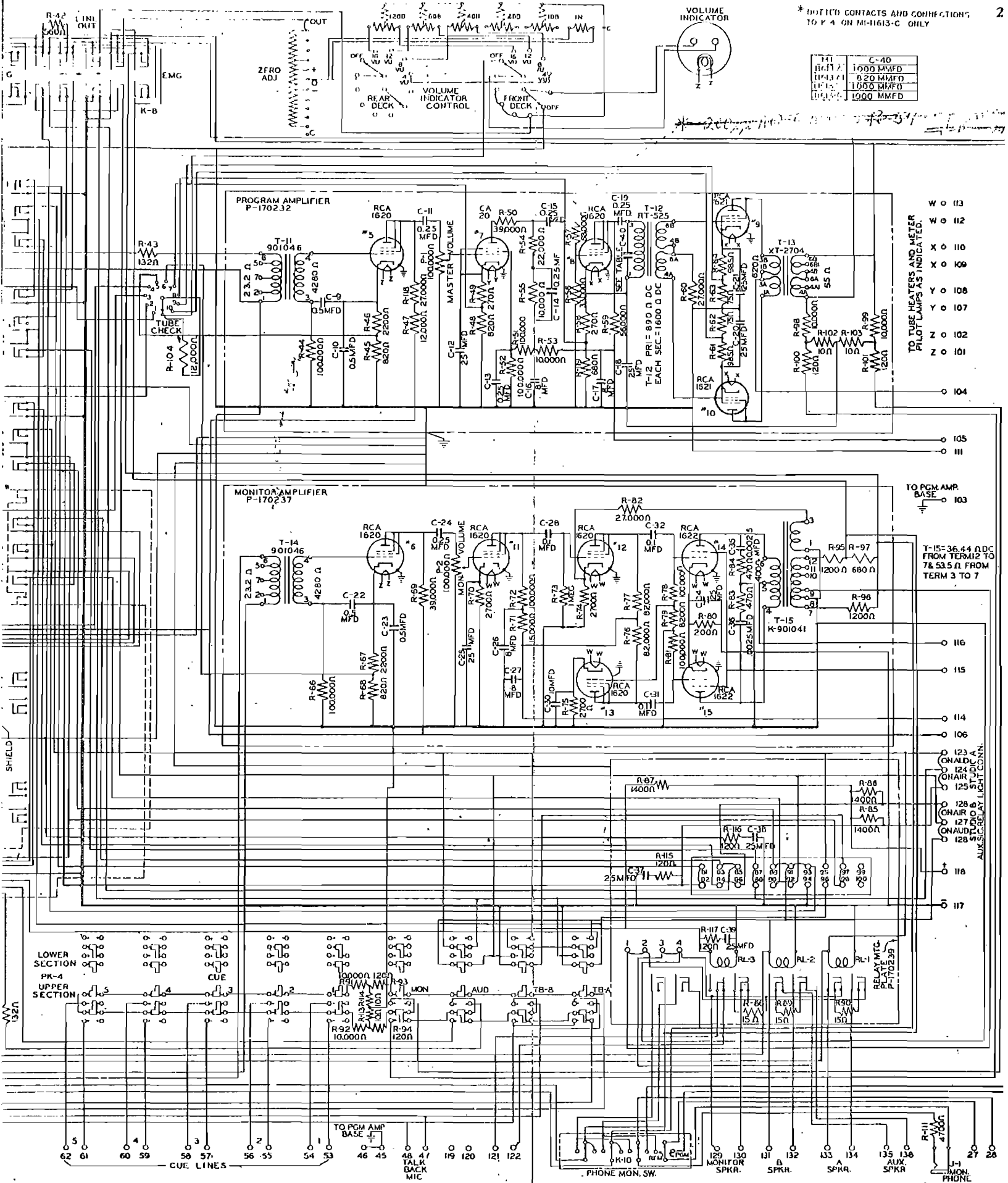

Figure 16—Schematic Diagram (W-13197)

TYPES 76-B2 AND 76-B4 RCA CONSOLETTES

PART III

MI-11301-B Power Supply

TECHNICAL DATA

Power Required

100 to 130 volts
50 to 60 cycles
225 watts

Fuses

Transformer T-1: 2 amp.
Transformer T-2: 1 amp.
Transformer T-3: 1 amp.

Tubes

1 RCA-5U4G Rectifier
1 RCA-5Y3 GT/G Rectifier

Dimensions and Weight

Height 15 inches
Width 15 inches
Depth 8 inches
Depth 15 $\frac{5}{8}$ inches (opened)
Weight 60 pounds

Mounting

Wall or cabinet mounting

Power Supplied*a. D-C Plate Voltage (with respect to term. 17)*

Term. No.	Volts	Ma.
4	285	42
5	220	4.6
6 REG	245	16
6 EMG	200	13
14	278	5.1
15	210	1.2
16	375	62

b. A-C Heater Supply

Terminals no. 1 and 2: 6.2 volts at 2.4 amp.
Terminals no. 7 and 8: 6.2 volts at 0.3 amp.
Terminals no. 9 and 10: 6.2 volts at 1.6 amp.
Terminals no. 12 and 13: 6.2 volts at 2.7 amp.

c. D-C Field Supply

Terminals no. 19 and 20: 100 ma to one, two, or three, 100-volt, 10 watt loudspeaker fields.

d. D-C Relay Supply

Terminals no. 17 and 18: 60 volts at 100 ma.

DESCRIPTION

The MI-11301-B Power Supply furnishes plate, heater and relay requirements for the RCA 76-B series of Consolettes. It also supplies loudspeaker field power for a maximum of three 100-volt, 10-watt loudspeaker fields.

The cabinet is provided with ventilating screens at the top and bottom. The conduits which carry the wiring to the unit are brought into the power supply through knockout holes in the sides of the cabinet. External connections are made to a terminal board at the left of the chassis. Tubes, terminal connections, fuses, resistors and wiring are accessible when the hinged door is opened to the right. Other resistors, capacitors and transformers are mounted on the back of a hinged chassis which may swing outward for testing and servicing. A door is provided which removes the

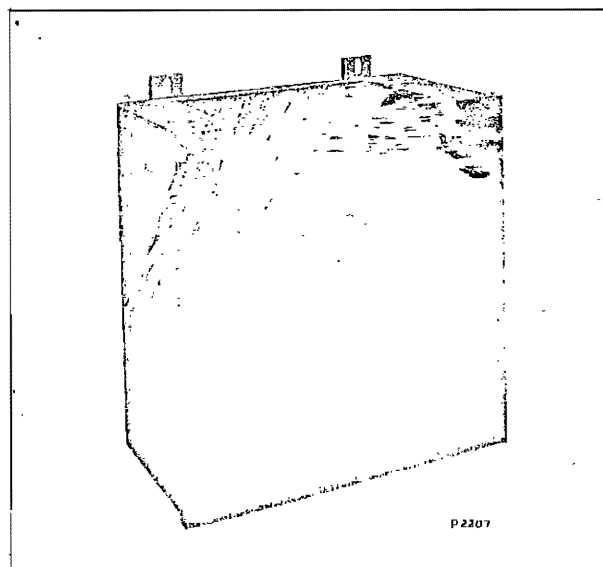

Figure 17—MI-11301-B Power Supply

power from the circuit when the door is opened. A POWER ON-OFF toggle switch is mounted on the side of the cabinet.

The power supply may be used to furnish power for any of the following equipment:

- a. MI-11612 Consolette (Type 76-B).
- b. MI-11613 Consolette (Type 76-B1).
- c. MI-11613-A Consolette (Type 76-B2).
- d. MI-11613-A1 Consolette (Type 76-B2).
- e. MI-11613-B Consolette (Type 76-B2).
- f. MI-11613-C Consolette (Type 76-B4).

INSTALLATION

Mounting

The MI-11301-B Power Supply is designed for wall mounting and is provided with two mounting brackets. Refer to the mounting dimensions diagram, figure 18. The power supply should be mounted near the Consolette to reduce wiring, but not closer than three feet to avoid hum induction.

Connections

All connections should be made to the terminal board at the left of the chassis. Conduits may be attached through the knockouts in the side of the

case. The screw-type terminals are numbered and the corresponding numbers, with their power supply connections, are shown in the schematic diagram figure 21. Size and type of wire and conduit are listed in the *Conduit List* on page 11.

Loudspeaker Field Supply

To connect one, two, or three 1,000-ohm, 10-watt loudspeaker fields, such as the 64-A or 64-B Electrodynamic Speakers, proceed as follows:

- a. Remove the jumper between terminals 19 and 20 on the power supply terminal board.
- b. Connect the loudspeaker fields between these same two terminals. If two or three fields are used, connect the fields in series.
- c. Omit one, two, or three 1,000-ohm sections of resistor R-1, corresponding to the number of loudspeaker fields in the circuit. This is done by moving the connection of either lead to resistor R-1. (The 600-ohm section of R-1 is not to be used.) R-1 is mounted on the back of the hinged chassis.

Emergency Switch

A toggle switch is mounted on a bracket at the lower center of the chassis. This switch has two positions, REGULAR and EMERGENCY. When

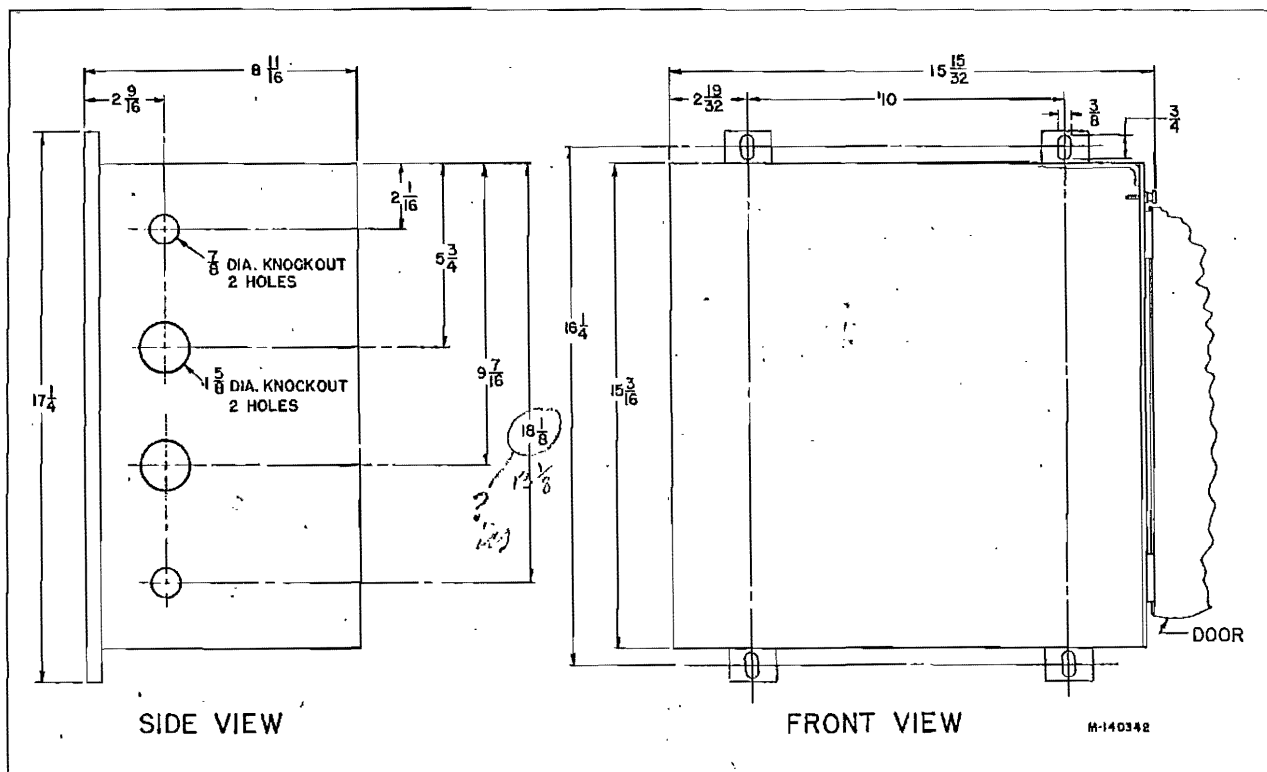

Figure 18—Mounting Dimensions (MI-11301-B Power Supply)

the switch is thrown to the EMG position, the monitor amplifier power supply furnishes the power for the microphone preamplifiers and booster amplifiers. The monitor amplifier is then used in place of the program amplifier in the Console.

Hum Adjustment

If it becomes necessary to make a hum adjustment on the Console, the following procedure is recommended:

Load the microphone lines (nos. 1, 2, 3, and 4) with 250-ohm resistors. Set the MASTER control and the mixer controls (1, 2, 3, and 4 attenuators) for 67 db or normal gain. Connect an amplifier having approximately 60 db gain to the LINE OUT terminals of the Console, then adjust the hum potentiometers P-1 and P-2 on the Power Supply, for minimum hum. (The LINE OUT switch must be set at the REG position and the associated mixer switches on PROGRAM).

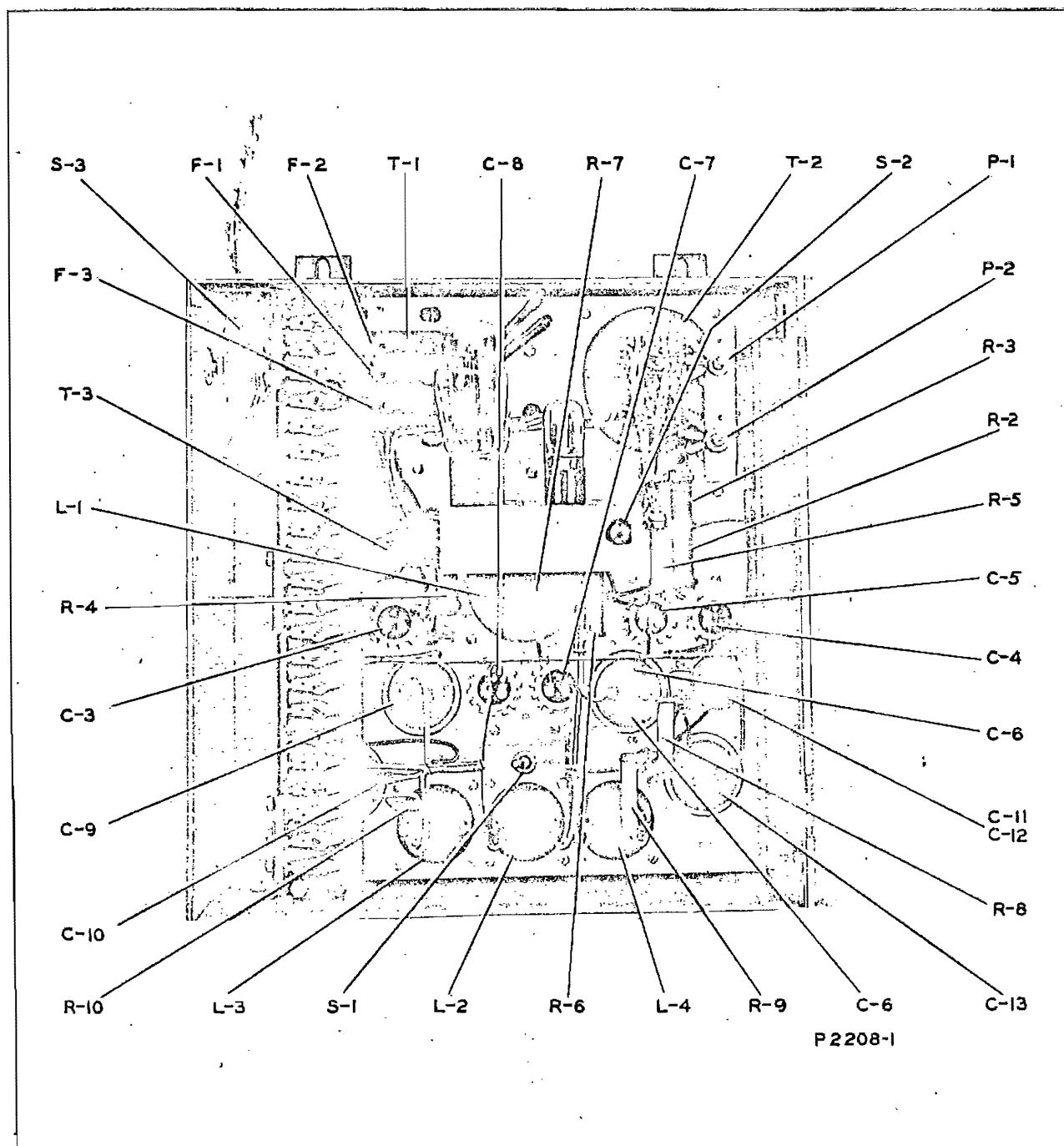

Figure 19—Interior View of Power Supply

Figure 20 — Wiring Diagram (MI-17301-B Power Supply)

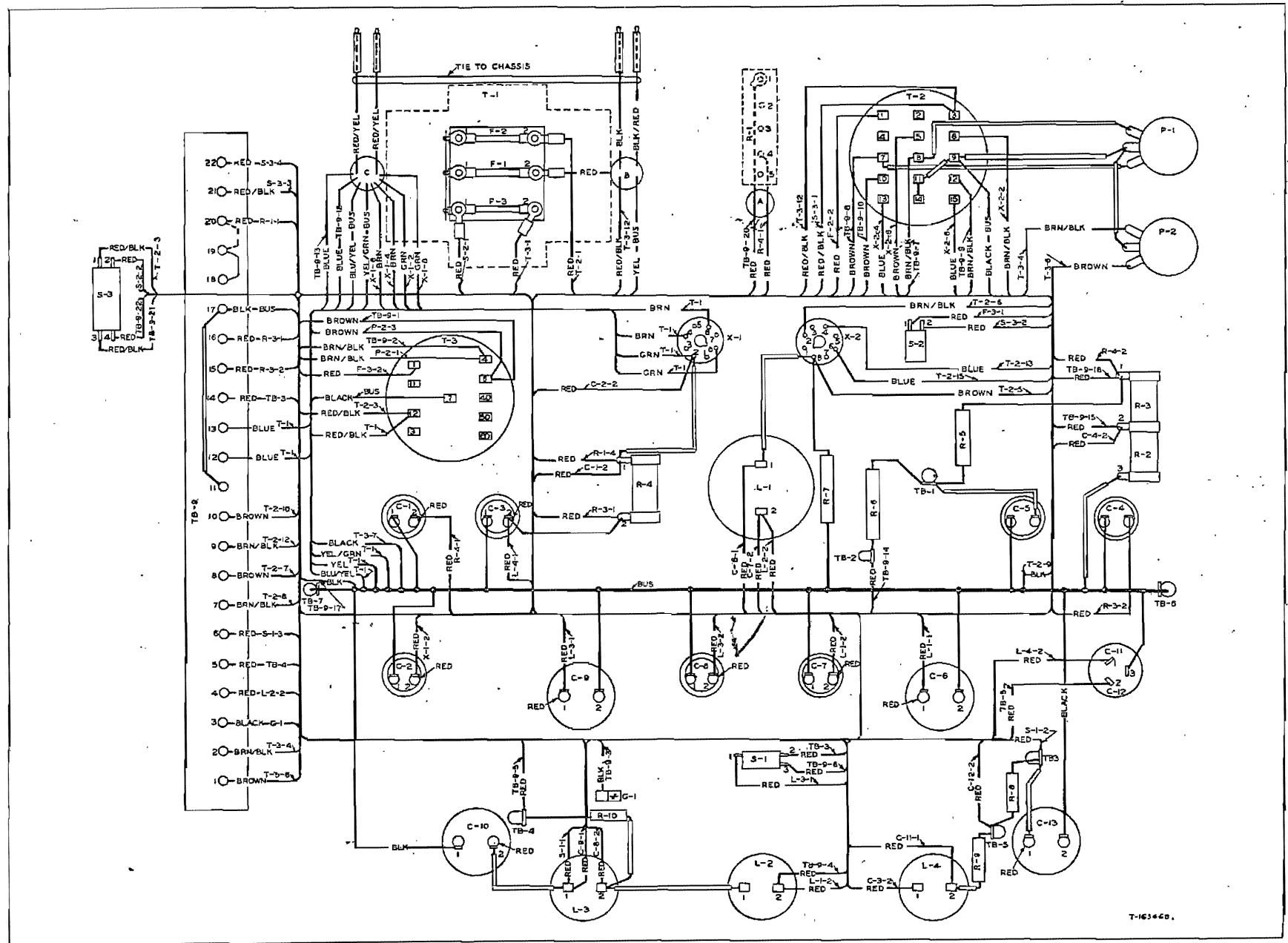
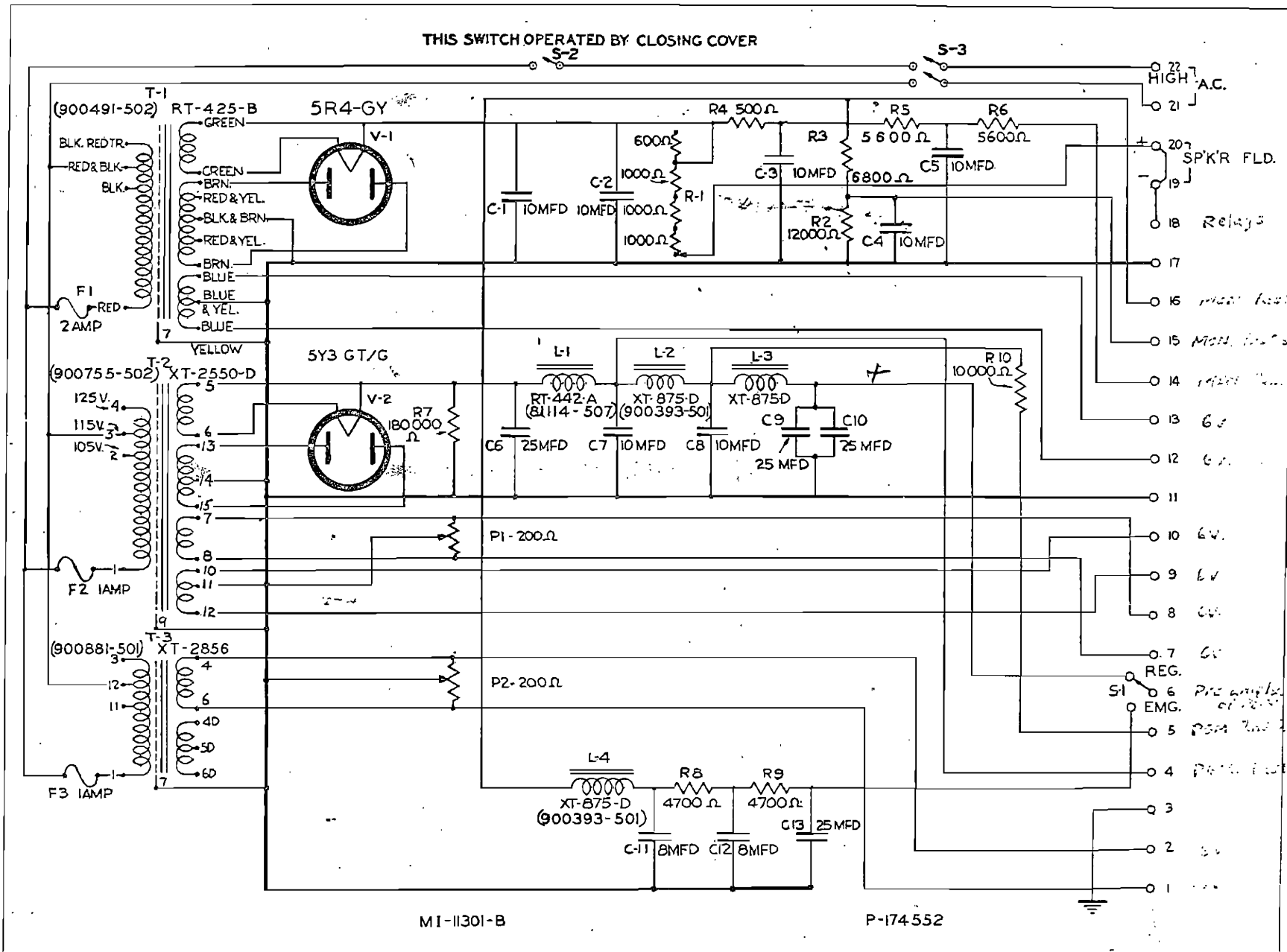

Figure 21 — Schematic Diagram (MI-11301-B Power Supply)



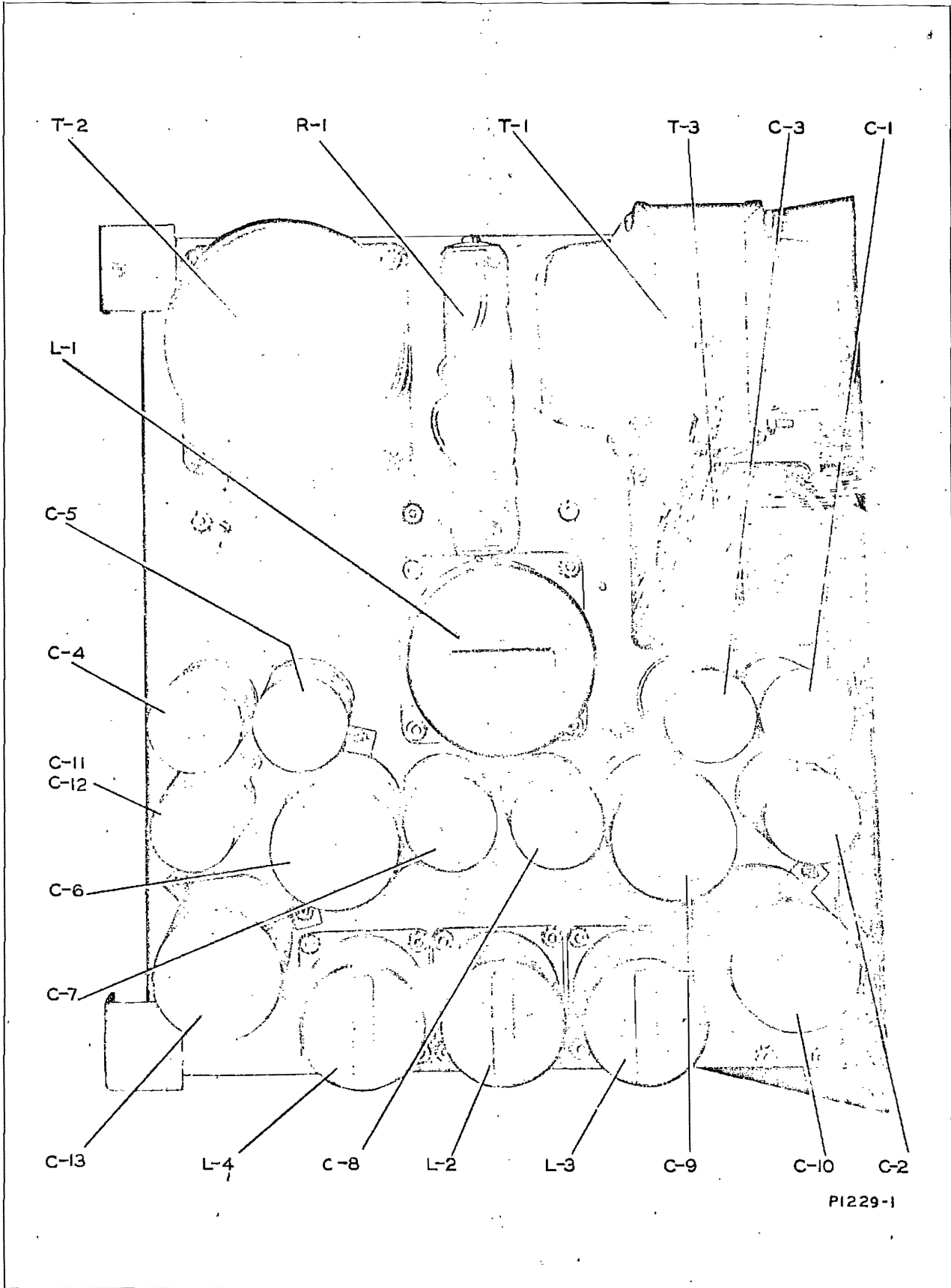

Figure 22—Rear View of Power Supply Chassis

PART IV

Maintenance

TUBE CHECK READINGS

Selector Switch Setting	Tube	Meter Reading	Selector Switch Setting	Tube	Meter Reading
1	RCA-1620, preamplifier number 1	70 ± 10	6	RCA-1620, 1st stage of monitor amplifier	70 ± 10
2	RCA-1620, preamplifier number 2	70 ± 10	7	RCA-1620, 2nd stage of program amplifier	70 ± 10
3	RCA-1620, preamplifier number 3	70 ± 10	8	RCA-1620, 3rd stage of program amplifier	70 ± 10
4	RCA-1620, preamplifier number 4	70 ± 10	9	RCA-1621, output stage of program amplifier	70 ± 10
5	RCA-1620, 1st stage of program amplifier	70 ± 10	10	RCA-1621, output stage of program amplifier	70 ± 10

INSPECTION AND CHECKING

Particular attention has been paid in the design of the 76-B2 and 76-B4 Console to provide the best facilities for reaching and servicing the component parts. The lid of the Console is hinged so that the tubes are accessible for inspecting and servicing. It may be opened by turning the two spring catches through 90 degrees with a thin coin or small screwdriver. The upper section of the cabinet may also be raised to expose the terminal boards and other components.

For any piece of equipment that is subject to continuous use, as is most broadcast equipment, a regular routine of inspection should be set up and followed to avoid time off the air as a result of tube failure, or noisy circuits caused by accumulation of dirt on terminals and switches, corroded plugs, etc. It is advisable to carry one complete set of spare tubes in case of emergency.

The regular inspection should include checking the tubes. To check the tubes, first turn the VU CONTROL to the OFF position. The bias voltage of all tubes in the program channel may then be checked by turning the TUBE CHECK switch to its

various positions and observing the VU meter readings. The bias voltage provides an indication of the flow of plate current, thereby giving an indication of the condition of the tubes. The normal meter readings for the tubes are listed below. These readings were taken with an a-c line voltage of 115 volts, the power transformers of the MI-11301-B Power Supply being connected for 115 volt operation.

The tube socket and Radiotron cap contacts should be cleaned with carbon tetrachloride or crocus cloth every three months to insure noiseless operation.

The mixer and MASTER control switch contacts should be cleaned by applying Davenoil to the contacts, rotating the knob, and, if any dark streaks appear, wiping off the contacts. Repeat this procedure until absolutely clean, then lubricate with a thin film of Davenoil. The Davenoil is included as a part of the equipment.

IMPORTANT: The Davenoil is provided for cleaning and lubricating the contacts of the mixers and volume controls and no other cleaning agent, such as carbon tetrachloride, should be used.

Care of Pushbutton Switches

Pushbutton switches of the 76-B2 (MI-11613-B) Consolette should be cleaned every four to six months, or more often if dust and climatic conditions make it necessary. They should be cleaned as follows, using the pushbutton cleaning kit supplied with the Consolette.

- a. Turn off the power supply.
- b. Open the panel and place a trouble lamp behind the switch that is to be cleaned first.
- c. Pull the black pushbuttons from the switches to be cleaned. The switch contacts will then be seen by looking into the plunger-rod hole with the aid of the trouble lamp.
- d. Dip the brush into the special cleaning lubricant and drain off the excess.
- e. Insert the brush into the plunger-rod hole and rub it over the contacts five or six times. Then push the plunger half way in to clear the contacts that are normally covered by the contact springs and repeat the process.
- f. Push the plunger in and out several times to work the cleaning lubricant under the contact springs.
- g. Wipe the brush on a clean cloth and repeat d, e, and f.
- h. Clean the remaining switches as directed in e, f, and g, and replace the pushbuttons.

Pushbutton switches of the 76-B4 Consolette (MI-11613-C) are of a different type than those used on the 76-B2. They should not require cleaning under normal circumstances, but if noise is encountered as a result of dirty pushbutton contacts, they may be cleaned from the rear of the panel as follows:

- a. Remove the two screws at the extremes of the pushbuttons and pull the switch assemblies back from the panel without removing any of the connecting wires.
- b. Using a toothpick or similar object, apply a drop of Davenoil through each of the small eyelet holes directly over the switch contacts.

c. Work the plungers in and out and remove the excess oil from the switch assemblies.

- d. Replace the switch assemblies.

Care of Key Switches on 76-B2 and 76-B4 Consolettes

As shipped from the factory, the various key switch contacts have been adjusted to give the proper sequence of circuit connections as they are operated so that a microphone and speaker will not be on at the same time in a studio and thus cause acoustic feedback. In case a replacement key switch is installed, or if feedback trouble is encountered, the contacts should be adjusted using a standard key-switch or relay-contact bending tool. When adjusting the switches, the following desired sequence of operation should be kept in mind: *The relay contacts must operate first and the audio circuits transfer last.* This is accomplished by relieving the tension of the center spring of the form D contacts controlling the relays, and increasing the tension of the center spring of the form D contacts carrying audio. Care should be taken that the spring shape is not altered, or the contact pressure reduced so much as to cause poor contact or short circuits. To remove the key switch shield, it is only necessary to remove the two screws in the contact "pile-ups" of the switches at the ends of the switches.

The loudspeaker cut off is accomplished with relays and cannot be instantaneous. For quiet operation the key switches should be operated smoothly, not abruptly snapped into position.

Voltage Measurements

Tube voltages for the preamplifiers, program amplifier, and monitor amplifier are listed below. To obtain the values listed below, all except heater voltages should be measured to ground using a d-c voltmeter with a meter resistance of 5,000 ohms per volt. Voltages listed are nominal and actual readings should not vary more than about 5% from the given values.

NOTE: If the voltmeter used has a meter resistance greater, or less than 5,000 ohms per volt, most readings taken will vary accordingly, the amount of variation depending upon the circuit in which the meter is used.

TUBE VOLTAGE TABLE

Preamplifier Voltages		
Tube Element		RCA-1620
Plate	d-c	220
Cathode	d-c	8.3
Heater	d-c	6.2

TUBE VOLTAGE TABLE (CONT'D)

Program Amplifier Voltages

Tube Element	1st RCA-1620	2nd RCA-1620	3rd RCA-1620	Each RCA-1621
Plate d-c	155	80	85	270
Screen d-c	70
Cathode d-c	6.0	1.9	2.2	23
Heater a-c	6.2	6.2	6.2	6.2

Monitor Amplifier Voltages

Tube Element	1st RCA-1620	2nd RCA-1620	Each RCA-1620 Phase Inverter	Each RCA-1622
Plate d-c	155	115	140	340
Screen d-c	220
Cathode d-c	5.8	4.3	5.0	12
Heater a-c	6.2	6.2	6.2	6.2

REPLACEMENT PARTS

The following list of parts is included to provide identification when ordering replacement parts. Order from *RCA Replacement Parts Department, Camden, New Jersey*, giving the *Stock Number* and *Description* of the parts wanted. Replacement parts supplied may be slightly different in form or size from the original parts but will be completely interchangeable with them.

LIST OF PARTS

Symbol	Description	Stock No.
MI-11301-B Power Supply		
C-1, -2, -3, -4, -5, -7, -8	Capacitor, 10 mf, 475 v	13224
C-6, -9, -10, -13	Capacitor, 25 mf, 475 v	13035
C-11, -12	Capacitor, 8-8 mf, 450-450 v	17432
F-1	Fuse, 2 amp.	3863
F-2, -3	Fuse, 1 amp.	14133
L-1	Reactor, RT-442-A	17568
L-2, -3, -4	Reactor, XT-875-D	17569
P-1, -2	Potentiometer, 200 ohms	18953
R-1	Resistor, 600-1,000-1,000-1,000 ohms	17167
R-2, -3	Resistor, 12,000-6,800 ohms	51373
R-4	Resistor, 500 ohms, 4.8 w	17451
R-5, -6	Resistor, 5,600 ohms, 2 w	8087
R-7	Resistor, 180,000 ohms, 2 w	19734
R-8, -9	Resistor, 4,700 ohms, 2 w	17248
R-10	Resistor, 10,000 ohms, 1 w	13097
S-1	Switch, REG-EMG, toggle	7925

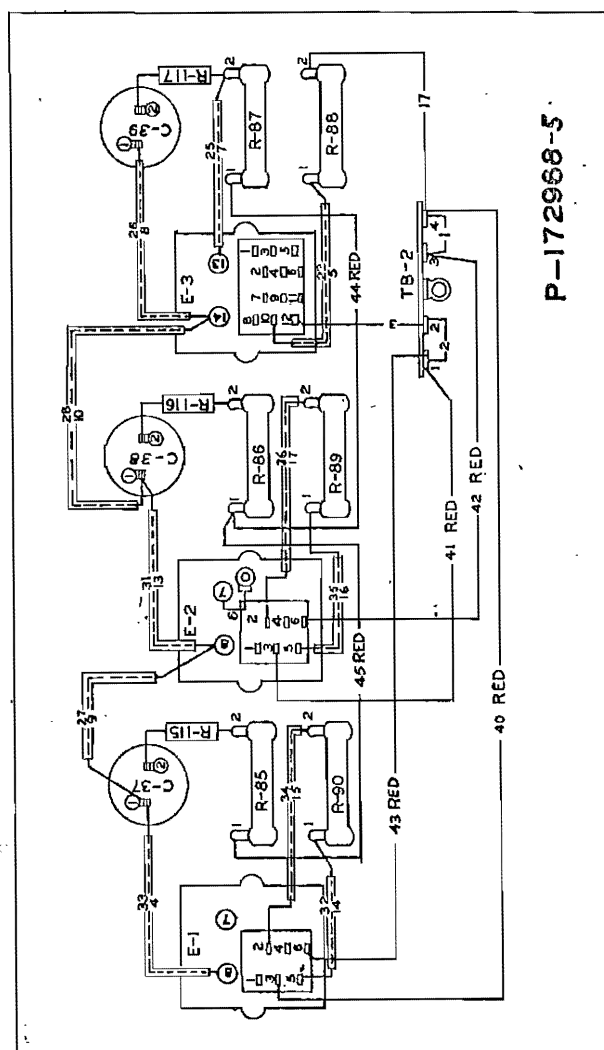

Figure 23—Relay Mounting Plate Wiring

P-172968-5

LIST OF PARTS (CONT'D)

Symbol	Description	Stock No.
MI-11301-B Power Supply (Cont'd)		
S-2	Switch, automatic cut-off	19433
S-3	Switch, power	15874
T-1	Transformer, power, RT-425-B	44068
T-2	Transformer, power, XT-2550-D	44683
T-3	Transformer, XT-2856 Clamp, capacitor	18237 14088
Pre-Amplifier Mounting Plate		
C-1 to C-8	Capacitor, 0.5 mf	52943
R-1	Resistor, 100,000 ohms	3252
R-2	Resistor, 560 ohms	5164
R-3	Resistor, 2,200 ohms	34767
R-4	Same as R-1	
R-5	Same as R-2	
R-6	Same as R-3	
R-7	Same as R-1	
R-8	Same as R-2	
R-9	Same as R-3	
R-10	Same as R-1	
R-11	Same as R-2	
R-12	Same as R-3	
T-1 to T-4	Transformer, input	43569
T-5 to T-8	Transformer, output Socket, (for RCA-1620)	17595 33084
Program Amplifier Mounting Plate		
C-9, C-10	Capacitor, 0.5 mf	52943
C-11	Capacitor, 0.25 mf	70618
C-12	Capacitor, 25 mf	26410
C-13, C-14, C-15	Capacitor, 0.25 mf	70618
C-16, C-17	Capacitor, 8/8 mf	17432
C-18	Same as C-12	
C-19	Same as C-13	
C-20, C-21	Same as C-12	
C-40	Capacitor, 1,000 mmf	39652
R-43	Resistor, 130 ohms	60079
R-44	Resistor, 100,000 ohms	3252
R-45	Resistor, 820 ohms	30158
R-46	Resistor, 2,200 ohms	34767
R-47	Resistor, 12,000 ohms	30436
R-48	Resistor, 820 ohms	30158
R-49	Resistor, 270 ohms	30929
R-50	Resistor, 39,000 ohms	30147
R-51, R-52	Same as R-44	
R-53	Resistor, 10,000 ohms	13097
R-54	Resistor, 22,000 ohms	30492
R-55	Resistor, 10,000 ohms	3078
R-56	Resistor, 33,000 ohms	30685
R-57	Resistor, 68,000 ohms	14138
R-58	Same as R-49	
R-59	Resistor, 56,000 ohms	17440
R-60	Resistor, 27,000 ohms	30409
R-61 to R-64	Resistor, 985-75-75-985 ohms	17606

Symbol	Description	Stock No.
Program Amplifier Mounting Plate (Cont'd)		
R-98, R-99	Resistor, 10,000 ohms	3078
R-100, R-101	Resistor, 120 ohms	30189
R-102, R-103	Resistor, 10 ohms	34761
R-118	Resistor, 27,000 ohms	13477
R-119	Resistor, 680 ohms	12262
T-11	Transformer, input	43569
T-12	Transformer, interstage	17427
T-13	Transformer, output Socket, (for RCA-1620 & RCA-1621)	17567 33084
Relay Mounting Plate		
C-37, C-38, C-39	Capacitor, 25 mf	26410
R-85, R-86, R-87	Resistor, 1,400 ohms	18235
R-88, R-89, R-90	Resistor, 15 ohms	18236
R-115, R-116, R-117	Resistor, 120 ohms	30189
RL-1, RL-2	Relay	19186
RL-3	Relay	18292
Transformer Mounting Plate		
R-105	Resistor, 560 ohms	5164
R-106	Resistor, 220 ohms	5201
R-107	Resistor, 39 ohms	11956
R-108	Resistor, 560 ohms	5164
R-109	Resistor, 220 ohms	5201
R-110	Resistor, 39 ohms	11956
T-9, T-10	Transformer	18230

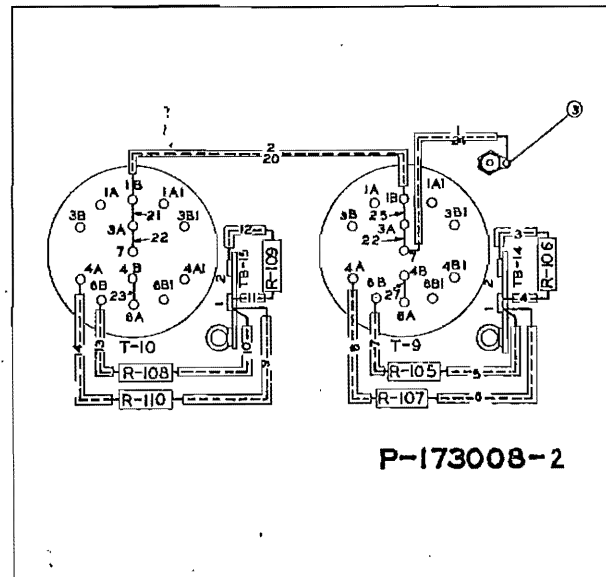
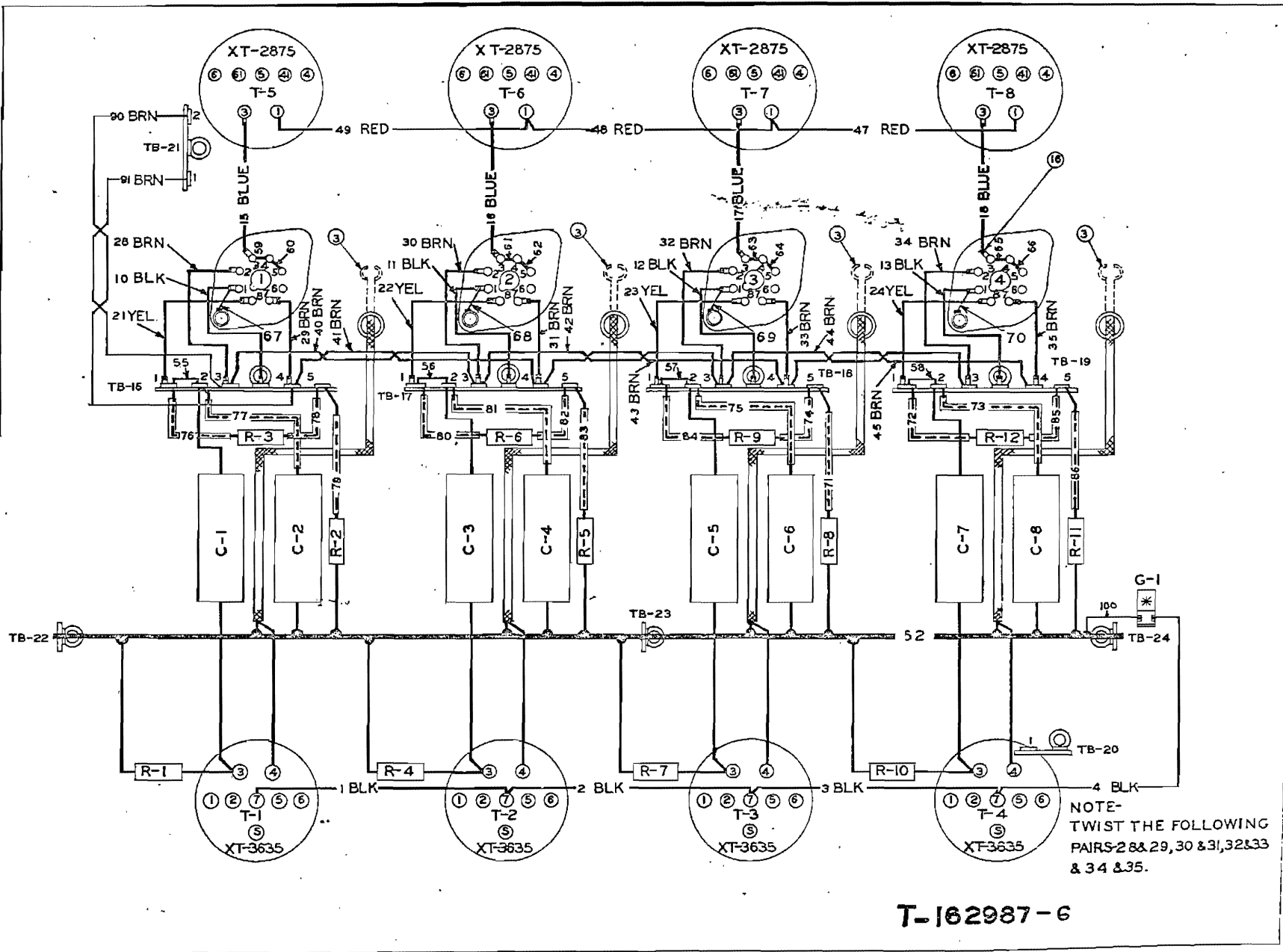
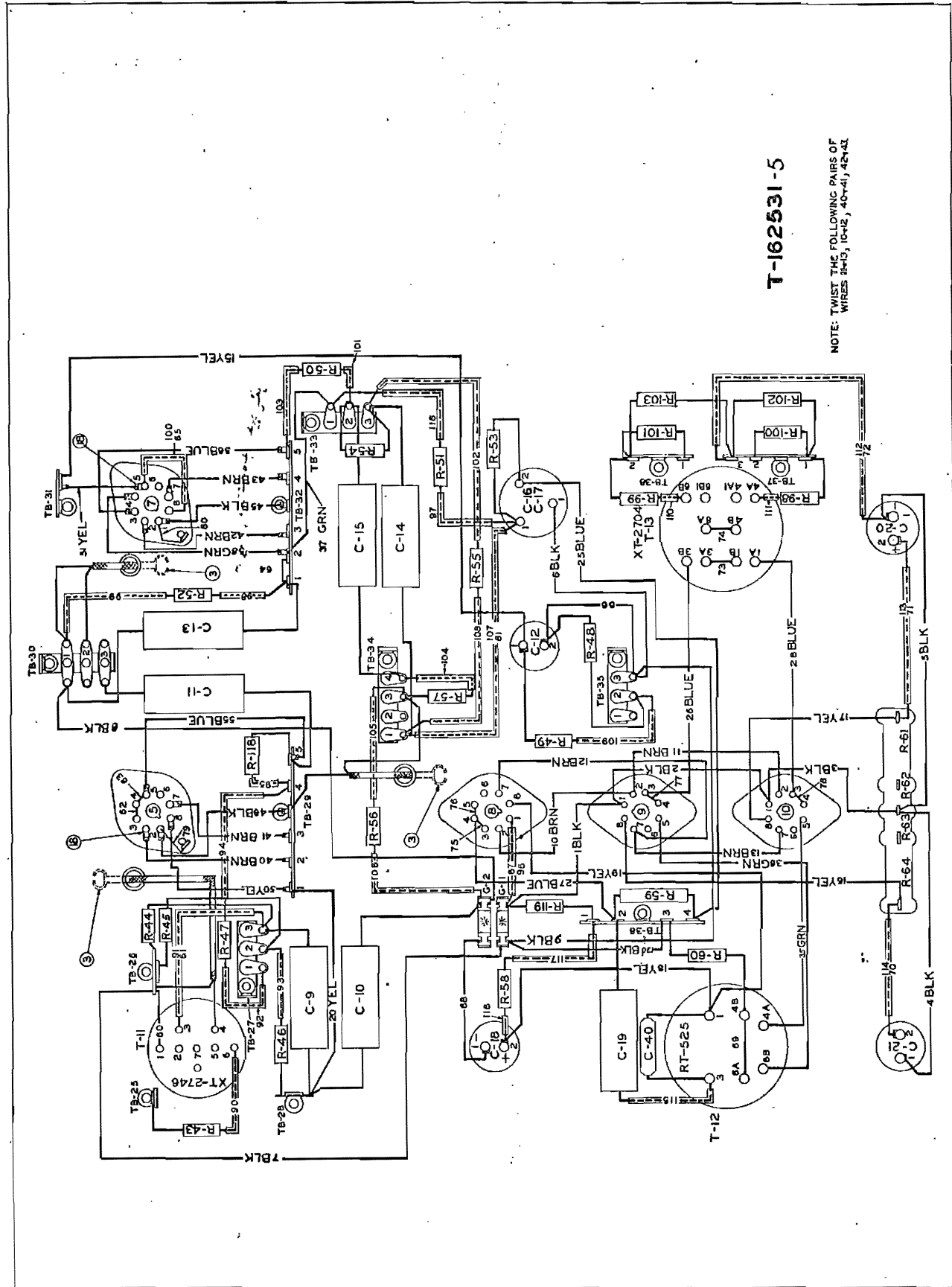

Figure 24—Line Transformer Wiring

Figure 25—Preamplifier Mounting Plate Wiring



T-162987-6



T-162531-5

NOTE: TWIST THE FOLLOWING PAIRS OF WIRES 24-13, 10-12, 40-41, 42-43

Figure 26—Program Amplifier Mounting Plate Wiring

Figure 27—Monitor Amplifier Mounting Plate Wiring

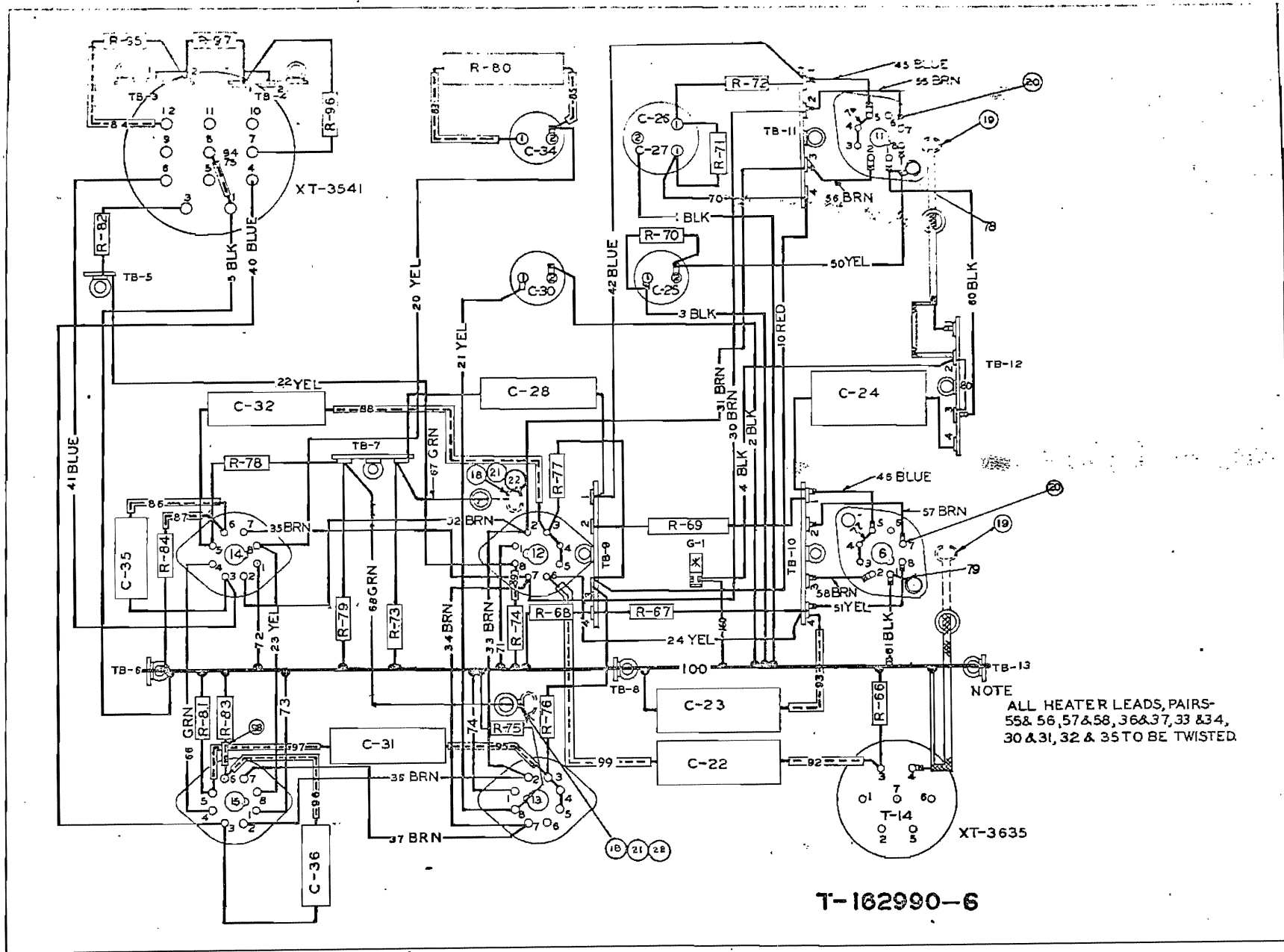

LIST OF PARTS (CONT'D)

Symbol	Description	Stock No.
Monitor Amplifier Mounting Plate		
C-22, C-23	Capacitor, 0.5 mf	52943
C-24	Capacitor, 0.25 mf	70639
C-25	Capacitor, 25 mf	26410
C-26, C-27	Capacitor, 8/8 mf	17432
C-28	Capacitor, 0.1 mf	70638
C-30	Capacitor, 10 mf	13222
C-31, C-32	Same as C-28	
C-34	Same as C-25	
C-35, C-36	Capacitor, 0.0025 mf	70644
R-66	Resistor, 100,000 ohms	3252
R-67	Resistor, 2,200 ohms	34767
R-68	Resistor, 820 ohms	30158
R-69	Resistor, 39,000 ohms	30434
R-70	Resistor, 2,700 ohms	30730
R-71	Resistor, 15,000 ohms	36714
R-72	Resistor, 100,000 ohms	3252
R-73	Resistor, 1 megohm	30652
R-74, R-75	Resistor, 2,700 ohms	30730
R-76, R-77	Resistor, 82,000 ohms	8064
R-78	Resistor, 100,000 ohms	3252
R-79	Resistor, 8,200 ohms	14250
R-80	Resistor, 200 ohms	30287
R-81	Resistor, 100,000 ohms	3252
R-82	Resistor, 27,000 ohms	30409
R-83, R-84	Resistor, 470 ohms	30681
R-95, R-96	Resistor, 1,200 ohms	30731
R-97	Resistor, 680 ohms	12262
T-14	Transformer, input	43569
T-15	Transformer, output Socket, (for RCA-1620 & RCA-1622)	43679 33084
Front Panel Assembly		
J-1	Jack, phones	16999
K-1 to K-3	Switch key, A-P #1 to #3	18290
K-4	Switch key, A-P #4 (MI-11613-B only)	18290
K-4	Switch key, A-P #4 (MI-11613-C only)	53431
K-5, K-6	Switch, key, A-P #5, #6	17910
K-7	Switch, key, "Announce"	19432
K-8	Switch, key, "Line Out"	18291
K-9, K-10	Switch lever, "Override- Off-Record," "Phone-Mon"	19573
PK-1	Switch, pushbutton #1 (9 Keys)	18317
PK-2	Switch, pushbutton #2 (9 Keys)	18318
PK-3	Switch, pushbutton #3 (9 Keys)	19572
PK-4	Switch, pushbutton #4 (9 Keys)	18320

Symbol	Description	Stock No.
Front Panel Assembly (Cont'd)		
R-13 to R-18	Resistor, 270 ohms (at Mixer 1-6 Resp.)	54264
R-19 to R-30	Resistor, 750 ohms (at Switch K-1 to K-6)	19785
R-31 to R-36	Resistor, 560 ohms (at Switch K-8, K-9; PK-1 to PK-3)	5164
R-38, R-39	Same as R-31	
R-40, R-41	Resistor, 270 ohms (at PK-2)	30929
R-42	Same as R-31	
R-65	Resistor, 132 ohms (at Switch K-6)	60079
R-91, R-92	Resistor, 10,000 ohms, 1/2 W.	3078
R-93, R-94	Resistor, 120 ohms, 1/2 W.	30189
R-104	Resistor, 12,000 ohms (at Tube Check)	30436
R-111	Resistor, 4,700 ohms (at Jack J-1)	30494
R-113, R-114	Resistor, 10 ohms, 1/2 W.	34761
R-121, R-122	Resistor, 5,600 ohms (at Switch K-9)	30734
R-123	Same as R-31	
R-124, R-125	Resistor, 10,000 ohms (at PK-3)	3078
R-127, R-128, R-130, R-131, R-133, R-134, R-136, R-137, R-139, R-140	Same as R-124	
.....	Attenuator, (#1 to #6)	17644
.....	Attenuator, master	17643
.....	Attenuator, monitor	17604
.....	Handle	54532
.....	Knob, for Attenuators #1 to #8	17269
.....	Knob, for Tube Check or VI Switches	17268
.....	Knob, for K-9 and K-10	54534
.....	Lubricant, for push button switches	44275
.....	Meter, VU and Tube Check	43186
.....	Oil, attenuator oil	20752
.....	Pad, multiple pad (7100/3900 ohms)	19328
.....	Pad, zero adjusting network (800 ohms)	19327
.....	Switch, tube-check	19571
.....	Switch, VI control	19570

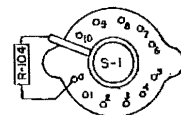
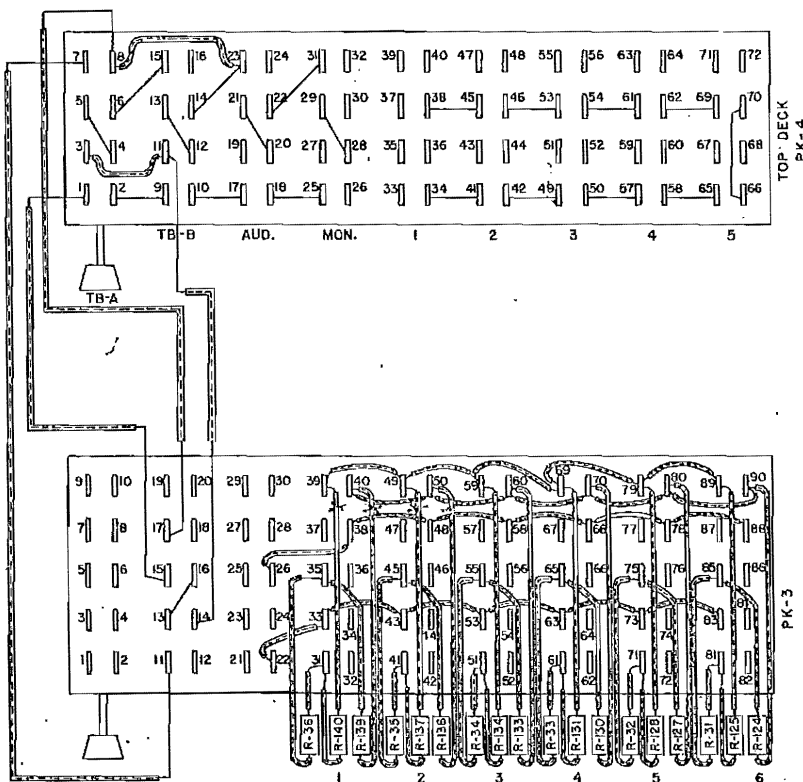
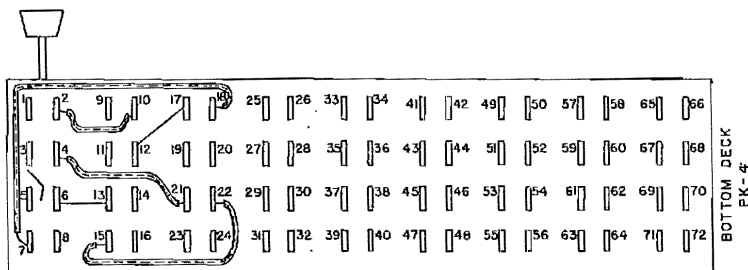
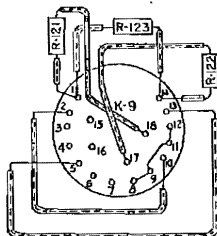
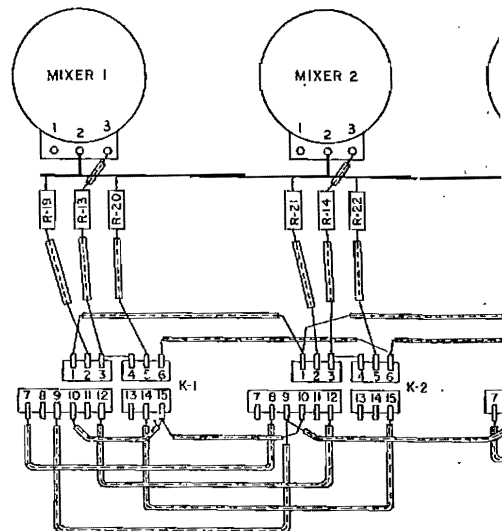
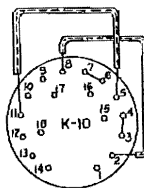
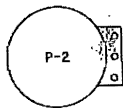
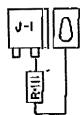

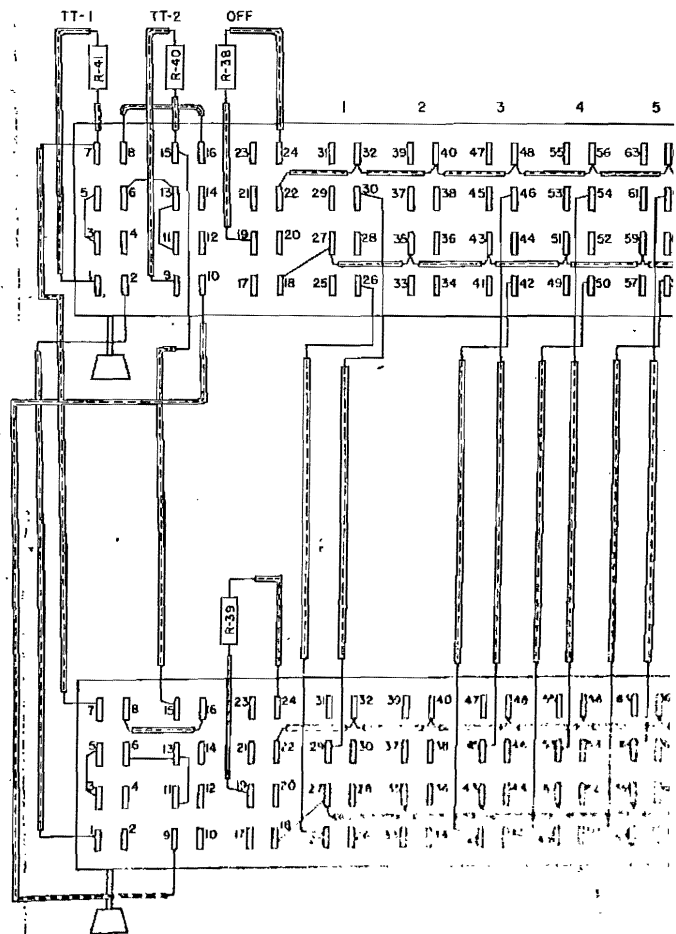
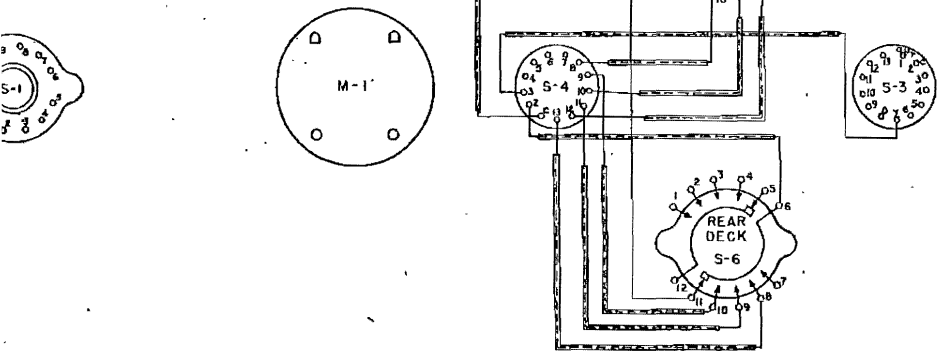
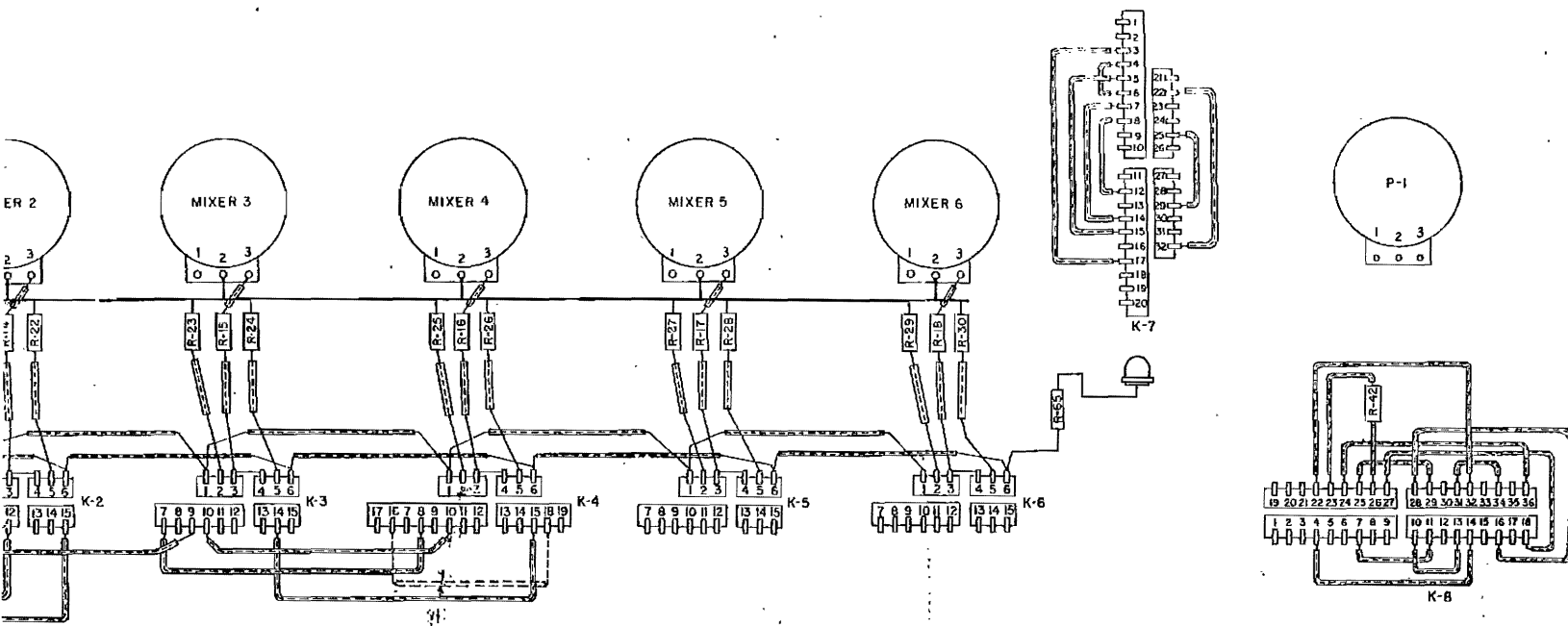

M1-11613-C IS SAME AS M1-11613-B, EXCEPT FOR DOTTED CONNECTION ON K-4

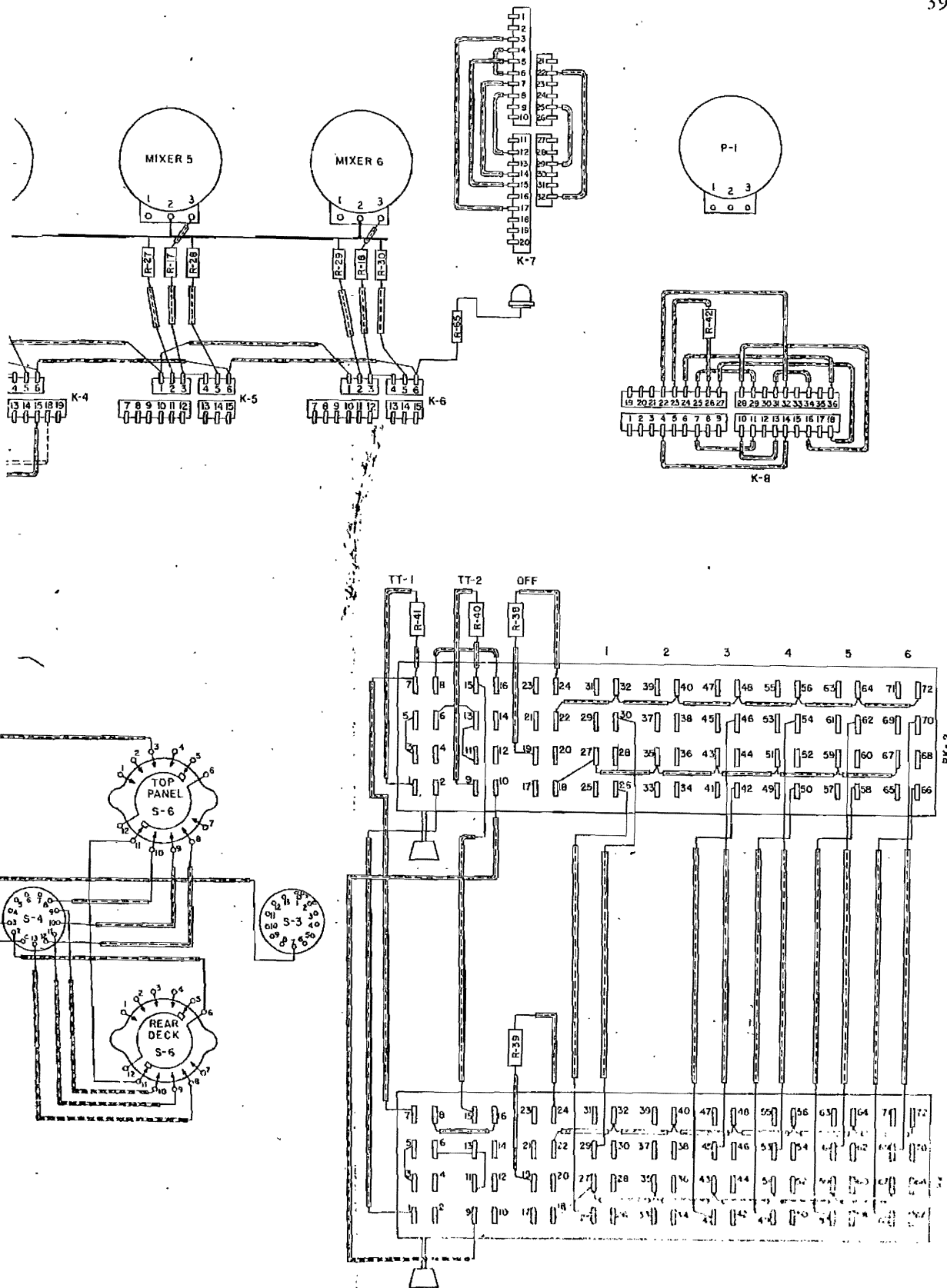

Fig. 28. Final Circuit Wiring (WV 111470)