

# Model AMM-2B AM MODULATION MONITOR

## Guide to Operations



**BELAR** ELECTRONICS LABORATORY, INC.

119 LANCASTER AVENUE  
P.O. BOX 76  
DEVON, PA 19333-0076 USA  
(610) 687-5550 • FAX (610) 687-2686

1	General Information . . . . .	1
	1-1 General Description . . . . .	1
	1-2 Physical Description . . . . .	1
	1-3 Electrical Description . . . . .	1
	1-4 Electrical Specifications . . . . .	2
	1-5 Mechanical Specifications . . . . .	3
	1-6 Instrument Identification . . . . .	3
	1-7 Accessories . . . . .	3
2	Installation . . . . .	4
	2-1 Initial Inspection . . . . .	4
	2-2 Claims . . . . .	4
	2-3 Repacking for Shipment . . . . .	4
	2-4 Preparation for Use . . . . .	4
3	Operation . . . . .	7
	3-1 Initial Operation . . . . .	7
	3-2 Normal Operation . . . . .	8
	3-3 Transmitter Measurements . . . . .	8
	3-4 NRSC De-emphasis Modification . . . . .	8
4	Maintenance . . . . .	10
	4-1 Test Equipment . . . . .	10
	4-2 Modulation Meter Alignment Procedure . . . . .	10
	4-3 Peak Indicator Alignment Procedure . . . . .	11
5	Diagrams, Schematics and Parts Lists . . . . .	12

**Important Note about the Belar AMM-2B, the Belar AMM-2A, and the Belar AMM-2:**

This instruction manual covers models AMM-2B, AMM-2A and AMM-2.

The model AMM-2B is identical to the model AMM-2A except for front-panel cosmetics.

Below are the components used in the AMM-2 which differ from the AMM-2B:

A1 CARD

R40	R: METAL FILM 10.0k $\Omega$ 1%
R43	R: FIXED CARBON 10M $\Omega$ 5% 1/4W
R47	R: METAL FILM 6.19k $\Omega$ 1%
R61	R: METAL FILM 5.11k $\Omega$ 1%
U7	IC: NE536T
U8	IC: MC1741SCP1

CHASSIS

DS1 & DS2	NOT USED
M1	METER: CARRIER LEVEL 1120-0013
M2	METER: MODULATION 1120-0012
T1	TRANSFORMER: POWER CTC 3143

# **1 General Information**

## **1-1 General Description**

The Belar AMM-2B AM Modulation Monitor (FCC Type Approval #3-240), is an all solid state precision AM demodulator designed to meet the Federal Communications Commission requirements for measuring the total modulation characteristics of AM broadcast transmitters. Since the input circuitry is non-frequency discriminating, the AMM-2B is also suitable for measuring the modulation characteristics of shortwave transmitters as well as VHF transmitters. A switch is provided to measure either positive or negative polarities on the modulation meter and the adjustable peak indicator. Separate peak indicators are provided to indicate negative peaks in excess of 99% and positive peaks in excess of 125%. The AMM-2B incorporates a carrier-off alarm and a modulation calibrator to insure the accuracy of the readings at any time.

## **1-2 Physical Description**

The AMM-2B is constructed on a standard EIA 5¼ x 19-inch rack mount. Calibration adjustments are located within the unit and are accessible through the back cover. The AC power input, RF input, and monitor outputs are located at the rear of the AMM-2B chassis on individual connectors and rear terminal block. The AMM-2B is completely solid state, utilizing all silicon transistors and integrated circuits for long, trouble-free life. LEDs (light-emitting diodes) are used for the indicators to eliminate lamp burn-out. The individual circuits are constructed on a military-grade, glass-epoxy, plated, printed circuit board. High-reliability military and industrial grade components are used throughout.

## **1-3 Electrical Description**

The AMM-2B is a solid state, low-sensitivity, precision AM demodulator incorporating a highly linear, biased diode detector. The detector circuit will accurately demodulate AM envelopes of carriers from 200 kHz to 160 MHz. Various metering and testing provisions are contained within the monitor to measure transmitter output characteristics. These provisions include a zero center carrier level deviation meter; a peak-reading modulation meter, switchable to either positive or negative modulation polarity; a peak modulation light, adjustable from 40 to 130% peak modulation and switched with the modulation meter to either positive or negative modulation polarity; a peak modulation light that responds when the negative modulation exceeds 99%; a peak modulation light that responds when the positive modulation exceeds 125%; a DC-type modulation calibrator to check the ratio between the carrier level and peak modulation reading; a carrier-off light that responds when the carrier is less than 70% of nominal value (this may be set to other values by the change of a resistor value). Outputs obtained from the monitor include an output for aural monitoring, a distortion meter test

output, a transistor driver for carrier-off alarm, and a transistor driver for remoting each of the three peak lights. FCC type-approved remote metering of the AMM-2B may be externally provided for the carrier level deviation meter and modulation meter.

#### 1-4 Electrical Specifications

RF Frequency Range	200 kHz to 160 MHz
RF Sensitivity	5 to 10 Volts RMS
RF Input Impedance	1000 $\Omega$ standard 50 $\Omega$ optional
Modulation Meter Range	0 to 133% (switchable to either positive or negative peaks)
Carrier Level Meter Range	$\pm 30\%$
Modulation Meter Accuracy	2% at 100% modulation
Peak Modulation Indicator*	40 to 130% in less than (switchable to either positive 1% increments or negative peaks)
Peak Modulation Indicator Accuracy	2%
100% Negative Indicator*	Adjustable 85 to 100%
125% Positive Indicator*	Adjustable 100 to 130%
Carrier Off Alarm	Fixed to alarm with a 30% drop in carrier level
Frequency Response	0.5 dB from 20-25,000 Hz
Pulse Response	Overshoot less than 1%
Distortion	0.25% max. at 99% modulation
Signal to Noise Ratio	75 dB
Remote Metering	Meters may be remotely metered 5000 $\Omega$ external loop resistance
Aural Monitoring Output	+10 dBm, 600 $\Omega$
Aural Proof of Performance Output	5 Volts RMS
Power Consumption	8 watts, 115/230V, 50 to 400 Hz
Operating Temperature	0°C to +50°C

\* Peak modulation, 100% negative and 125% positive indicators are true ratio types and will hold their accuracies over a  $\pm 30\%$  input carrier level change.

**1-5 Mechanical Specifications**

Dimensions . . . . .	5¼" H X 8" D x 19" W (133 x 216 x 483 mm) (EIA Rack Mount)
Net Weight . . . . .	8 pounds (3.6kg)
Shipping Weight . . . . .	12 pounds (5.4kg)

**1-6 Instrument Identification**

The instrument is identified by the model number and a six digit serial number. The model number and serial number appear on a plate located on the rear panel. All correspondence to your Belar representative or to the Belar factory in regard to the instrument should reference the model number and complete serial number.

**1-7 Accessories**

The Belar AMM-2B Modulation Monitor may be used for remote monitoring of an AM transmitter with either the Belar MP-6B Remote Meter panel or the Belar RFA-2 AM RF Amplifier. The MP-6B Remote Meter panel contains a carrier level deviation meter, modulation meter and 3 peak lights.

In cases where complete duplication of the AMM-2B front panel indications is not required, or where interconnection wiring precludes the use of the MP-6B Remote meter panel, an unmounted modulation meter may be ordered from Belar. This meter is identical to the unit incorporated in the monitor and meets the FCC ballistics requirement.

The Belar RFA-2 AM RF amplifier provides preamplification and selectivity to permit direct off-air monitoring with the AMM-2B.

## **2 Installation**

### **2-1 Initial Inspection**

Check the shipping carton for external damage. If the carton exhibits evidence of abuse in handling (holes, broken corners, etc.) ask the carrier's agent to be present when the unit is unpacked. Carefully unpack the unit to avoid damaging the equipment through use of careless procedures. Inspect all equipment for physical damage immediately after unpacking. Bent or broken parts, dents and scratches should be noted. If damage is found, refer to Paragraph 2-2 for the recommended claim procedure. Keep all packing material for proof of damage claim or for possible future use.

The AMM-2B is shipped with an instruction book, three wire line cord, and four beige rack mount screws.

### **2-2 Claims**

If the unit has been damaged, notify the carrier immediately. File a claim with the carrier or transportation company and advise Belar of such action to arrange the repair or replacement of the unit without waiting for a claim to be settled with the carrier.

### **2-3 Repacking for Shipment**

If the unit is to be returned to Belar, attach a tag to it showing owner and owner's address. A description of the service required should be included on the tag. The original shipping carton and packaging materials should be used for reshipment. If they are not available or reusable, the unit should be repackaged in the following manner:

- a. Use a double-walled carton with a minimum test strength of 275 pounds.
- b. Use heavy paper or sheets of cardboard to protect all surfaces.
- c. Use at least 4 inches of tightly packed, industry approved, shock absorbing material such as extra firm polyurethane foam or rubberized hair. **NEWSPAPER IS NOT SUFFICIENT FOR CUSHIONING MATERIAL.**
- d. Use heavy duty shipping tape to secure the outside to the carton.
- e. Use large **FRAGILE** labels on each surface.
- f. Return the unit, freight prepaid, via air freight. Be sure to insure the unit for full value.

### **2-4 Preparation for Use**

The AMM-2B AM Modulation Monitor is designed to be mounted in a standard 19-inch rack mount. When mounted in a rack, a slight air space should be provided above and below the unit. When the monitor is mounted above high-heat generating

equipment such as power supplies and amplifiers, consideration should be given to cooling requirements which allow a free movement of cooler air around the AMM-2B. In no instance should the ambient chassis temperature be allowed to rise above 50°C (122°F). Mount the AMM-2B to the rack using the four rack-mount screws provided.

The Model AMM-2B can be operated from either a 105 to 125 Vac or 210 to 250 Vac single phase, 50 to 400 Hz power source. Make sure the unit is set for the proper voltage as follows:

*Units with serial number 133536 and lower:*

Unplug the line cord. Slide the switch (S1) to 115V or 230V position. Ensure that the fuse (F1) is the proper current rating for selected voltage (½A 250V for 115Vac, ¼A 250V for 230Vac). Plug the line cord back in.

*Units with serial number 133537 and higher:*

Unplug the line cord. Open the fuse compartment door and pull lever to remove fuse. Using needlenose pliers, pull the voltage select board straight out of the power entry module. While facing the rear of the unit, orient the voltage select board so the desired line voltage is face up and reads correctly ("120" for 115Vac operation, "240" for 230Vac operation. The "100" and "220" positions on the bottom of the board are not used.) Reinsert the board into the power entry module, install the proper fuse (½A 250V for 115Vac, ¼A 250V for 230Vac), close the fuse door, and plug the line cord back in.

The Model AMM-2B is supplied with a three-conductor power cable which, when plugged into an appropriate receptacle, grounds the unit. The offset pin on the power cable three-prong connector is the ground wire. To preserve the grounding feature when operating the unit from a two-contact outlet, use a three-prong to two-prong adaptor and connect the green pigtail on the adaptor to ground. Attach the power cable between the unit and the power source receptacle.

**CAUTION: DO NOT APPLY MORE THAN 15 VOLTS RF TO THE MONITOR OR THE RF INPUT CIRCUIT MAY BE DAMAGED! BEFORE APPLYING ANY RF INPUT, TURN CARRIER LEVEL CONTROL MAXIMUM COUNTERCLOCKWISE!**

Damage as a result of excessive RF input is *not* covered under the warranty.



Connect a coaxial cable between the monitoring probe on the transmitter (or RF Amplifier) and the RF INPUT connector J2 at the rear of main chassis.

A remote carrier level deviation meter and one remote modulation meter can be connected to terminals on TB1 on the rear panel of the AMM-2B. The remote metering circuits are activated when the REMote button is depressed. The equivalent series resistances of both external metering circuits must be equal to values of internal circuit resistances for proper operation of the monitor in the REMote mode. The required external resistances are 5.1 k $\Omega$  for the carrier level deviation circuit and 7.5 k $\Omega$  for the modulation meter circuit. If the total series resistance of the external loop and meter is less than the required value, resistors must be added to the line to obtain the required value. If one external metering circuit is not used, a resistor of the required value must be connected to TB1 in place of the external loop. When remoting meters via DC telephone pairs, it is advisable to split the added resistance equally between the two legs of the external loop and to place the added resistors at the monitor end. This helps balance the line and provides additional protection for the monitor from line transients, such as lightning.

The remote carrier level deviation meter (or substitute resistance) should be connected between terminals 9 and 10 of TB1. The remote modulation meter (or substitute resistance) should be connected between terminals 8 and 12. Proper meter polarity must be observed. Terminals 8 and 9 are positive.

As an example, if only a remote modulation meter is used, the remote modulation metering circuit, with series resistance adjusted to 7.5 k $\Omega$ , is connected to terminals 8 and 12. In order for the carrier level deviation meter to function properly with the REM button depressed, a 5.1 k $\Omega$  resistor must be connected between terminals 9 and 10.

The external loop resistances may be conveniently adjusted by putting the monitor in the CALibrate with a steady, unmodulated carrier. The external loop resistance for the modulation circuit is correct when depressing the REM button causes no change in the reading of the internal modulation meter. This technique may be used for the carrier level circuit, but since the carrier level deviation meter has a center zero, the carrier level should first be adjusted to either end of the meter scale using the CARRIER SET control. Any change in indicated carrier level deviation on the internal meter when the REM button is pushed indicated an incorrect external loop resistance.

Remote modulation meters should be obtained from Belar so that FCC meter ballistics are met.

Remote peak modulation lamps and a carrier level alarm may also be driven from terminals on TB-1. The peak lamp and carrier level alarm outputs are open transistor

collectors that are pulled to ground when the respective LEDs are lit. Terminal 1 of TB1 is a 5-volt source which is available to drive external lamps. If LED's are used as external indicators, a series resistor must be used to limit the current in each diode to an appropriate value. As an example, a remote peak modulation lamp would be connected between terminals 1 and 3 on TB1.

If a relay is used for any of the indicator outputs, it must be a sensitive (low current) type and the output transistor must be protected from the back EMF of the coil by a diode or other means.

### **3 Operation**

#### **3-1 Initial Operation**

1. Before turning the unit on, ensure that the unit has been configured to operate with the line voltage you will be using (see *Section 2-4 Preparation for Use*).
2. Depress the ZERO switch and release the REMOTE switch. Turn CARRIER SET control maximum counterclockwise.
3. Depress POWER switch. Note that the % CARRIER LEVEL DEVIATION meter is pegged to the left, the CARRIER OFF alarm light is on, and the MODULATION meter is approximately zero. Allow a few minutes warm-up.
4. After warm-up, the MODULATION meter will read zero. If it does not read zero but is only off a few percentage points, it may be set to read zero with the mechanical zero control on the meter. If the zero is off more than a few percentage points, the zero should be set according to *Section 4-2 Modulation Meter Alignment Procedure*. The electrical zero is stabilized by a feed-back operational amplifier and normally does not need re-adjustment.
5. Rotate the CARRIER SET control clockwise. The CARRIER OFF light will go out at approximately minus 30% carrier level deviation. Continue to rotate the control so that the CARRIER LEVEL DEVIATION meter reads zero. Note that this is the carrier level SET point.
6. Depress the CAL switch. The MODULATION meter will read 100% to verify the accuracy of the calibration. The +125% light will be on. (The -100% light will not be on in the calibrate mode.)
7. Adjust the PEAK MOD potentiometer to the point where the PEAK MOD light just turns on. This setting will be 100%.

8. Depress the POS or NEG switch for positive or negative modulation reading on the MODULATION meter and PEAK MOD light, and the monitor is ready for operation.

### 3-2 Normal Operation

For normal operation, leave the AMM-2B in POS position when broadcasting super-modulation. The MODULATION meter and PEAK MOD light will register the positive peaks. Nominal changes in RF level will not affect the accuracy of the -100%, +125%, or PEAK MOD lights.

The PEAK MOD control is usually set to a level slightly lower than +125%, say +120%, and the separate -100% and the +125% lights are used for the limits to insure the maximum level of modulation without exceeding the limits set by the FCC.

Percent carrier shift is read on the % CARRIER LEVEL DEVIATION meter as a change in carrier intensity during modulation.

### 3-3 Transmitter Measurements

Normal transmitter proof-of-performance measurements may be made with the AMM-2B. Frequency response, distortion, and noise measurements may be made through the rear panel AUDIO TEST jack J3. Five volts RMS is available at 100% modulation so that most distortion and noise analyzers may be used. Percent modulation is read on the MODULATION meter and percent carrier shift is read on the % CARRIER LEVEL DEVIATION meter.

### 3-4 NRSC De-emphasis Modification

This modification de-emphasizes the demodulated audio output of the Belar AMM-2A or AMM-2B AM Modulation Monitor. With the modification installed, the monitor's audio output frequency response closely approximates the interim NRSC de-emphasis characteristic.

This change affects the audio present at the AUDIO TEST output (J3), the AURAL MONITOR OUTPUT (TB1, screw 11) and the AUX DET OUTPUT (TB1, screw 6).

Parts required:

Quantity	Description	Belar Part No.
1	14.7k $\Omega$ 1% metal film resistor	0721-1472
1	4.64k $\Omega$ 1% metal film resistor	0721-4641
1	3900pF 2.5% 160V poly capacitor	0130-3922

Procedure:

Remove the existing R53 (15k $\Omega$  carbon resistor) from the A1 board by cutting the leads as close to the *resistor body* as possible. (See accompanying component layout sheet for R53 location).

Preform the modification parts by connecting the 4.64k $\Omega$  resistor and 3900pF capacitor in series and then connecting these two across the 14.7k $\Omega$  resistor as shown on the modification schematic. Use short leads and be careful not to use excessive heat when soldering the parts together.

Mechanically connect the modification network to the original R53 leads on the A1 board. Solder the network to these leads using as little heat as possible so the leads do not pull out of the board. This completes the modification.

## **4 Maintenance**

### **4-1 Test Equipment**

1. Voltmeter
2. High Frequency oscilloscope with 5" display
3. Linear modulator, output level of 5-10 volts RMS unmodulated\*
4. Low distortion oscillator

### **4-2 Modulation Meter Alignment Procedure**

1. Turn power off and set mechanical zero on meters.
2. Turn power on and allow to warm up for 15 minutes.
3. With Voltmeter measure voltage at U5 Pin 7. Voltage should be +15 Volts,  $\pm 0.5$  volt. Adjust R30 for correct reading.
4. With Voltmeter measure voltage at U5 Pin 4. Voltage should be -15 volts,  $\pm 0.5$  volt. Adjust R25 for correct reading.
5. Place Function Switch in ZERO position and Voltmeter at Pin 6 U5 and adjust R37 for Zero Volts.
6. Adjust R44 for Zero on Modulation Meter.
7. Apply an RF level of 5-10 volts to RF input, and adjust CARRIER SET to -0-deviation on Carrier Meter. Connect Oscilloscope at RF INPUT (J2) of monitor.
8. Apply a 1 kHz tone to modulator and adjust level for just 100% negative modulation as observed on oscilloscope. Depress NEG on Function Switch of AMM-2B. Monitor should indicate 100% modulation. If not, adjust METER AMP, R41, for correct reading.\*
9. Reduce modulation level to 90% on AMM-2B. Place Function Switch in POS position. Monitor should indicate 90% modulation. If not, adjust NEG AMP, R36, for correct reading.\*
10. Place Function Switch in CAL position. Monitor should indicate 100%. If not, adjust CAL ADJ, R14, for correct reading.

### 4-3 Peak Indicator Alignment Procedure

1. **CARRIER OFF INDICATOR:** Reduce CARRIER SET Potentiometer to -30% or less on CARRIER LEVEL Meter. CARRIER OFF Indicator should be on. This is a fixed comparator and no adjustment is provided.
2. **-100% PEAK INDICATOR:** Adjust CARRIER SET to -0- Deviation on CARRIER LEVEL Meter. Adjust modulation for 98% or greater. The -100% Indicator should be on. If not, adjust -100% R69, for correct indication.
3. **PEAK MOD INDICATOR:**
  - a) Place Function Switch in POS position. Adjust modulation level for 90% on AMM-2B. Adjust PEAK MOD Potentiometer on front for 90%\*. If the PEAK MOD potentiometer R1 reads in error, the knob may be slipped to correct reading by loosening the two set screws and retightening after adjusting.
  - b) The span of the PEAK MOD Potentiometer may be checked by applying a 1 kHz tone to the Modulator and adjusting the modulation to 90% on the AMM-2B. Adjust PEAK MOD Span Potentiometer, R60, so that the percentage *difference* on the PEAK MOD Potentiometer on the front panel is 50% when the modulation level is changed from 90% to 40%. Slip the knob as in step (a) above if it is necessary to correct the reading at 90% after the span has been adjusted.
4. **+125% PEAK INDICATOR:** Place Function Switch in CAL position. The +125% Indicator should be on. If not, adjust +125%, R65, for correct indication.

\* Note that the modulation meter and peak lights respond to peak values of modulation so that if there is distortion in the modulator, the peak indications will be the true peak values, i.e., the sum of fundamental and the harmonics or distortion products. The most common mistake made in calibrating AM monitors is to adjust the modulation level until carrier shut-off is reached. This is defined as 100% negative and, indeed, it is 100% negative, but the positive value is not necessarily 100%. If the distortion is 3% at this level (typical of many transmitters), the positive value of modulation may be anywhere from 97% to 103%, depending on the phase of the harmonics, and the monitor will read this. It is for this reason that we suggest the monitor be calibrated at just 100% negative on the negative indications and then to back off the modulation to 90% for the positive indications so they can be set in the region where the transmitter is more linear.

## 5 Diagrams, Schematics and Parts Lists

**Replaceable Parts.** This page contains information for ordering replaceable parts for the monitor. The tables that follow list the parts in alphanumeric order by reference designation and provides a description of the part with the Belar part number.

**Ordering Information.** To order a replacement part from Belar, address the order or inquiry to Belar and supply the following information:

- a. Model number and serial number of unit.
- b. Description of part, *including the reference designation and location.*

Orders may also be taken over the telephone. Parts orders can be put on your VISA, MasterCard, or American Express card, or we can ship them COD.

### REFERENCE DESIGNATORS

A	= assembly	J	= jack	S	= switch
BR	= diode bridge	L	= inductor	T	= transformer
C	= capacitor	M	= meter	TB	= terminal block
CR	= diode or LED	P	= plug	U	= integrated circuit
DS	= display or lamp	Q	= transistor	W	= cable
F	= fuse	R	= resistor	X	= socket
FL	= filter	RL	= relay	Y	= crystal
HDR	= header connector	RN	= resistor network		

### ABBREVIATIONS

BCD	= binary coded decimal	PIV	= peak inverse voltage
CER	= ceramic	POLY	= polystyrene
COMP	= composition	PORC	= porcelain
CONN	= connector	POT	= potentiometer
DPM	= digital panel meter	SEMICON	= semiconductor
ELEC	= electrolytic	SI	= silicon
GE	= germanium	TANT	= tantalum
IC	= integrated circuit	uF	= microfarads
k	= kilo = 1,000	V	= volt
M	= meg = 1,000,000	VAR	= variable
MOD	= modulation	VDCW	= dc working volts
MY	= mylar	W	= watts
PC	= printed circuit	WW	= wirewound
pF	= picofarads		

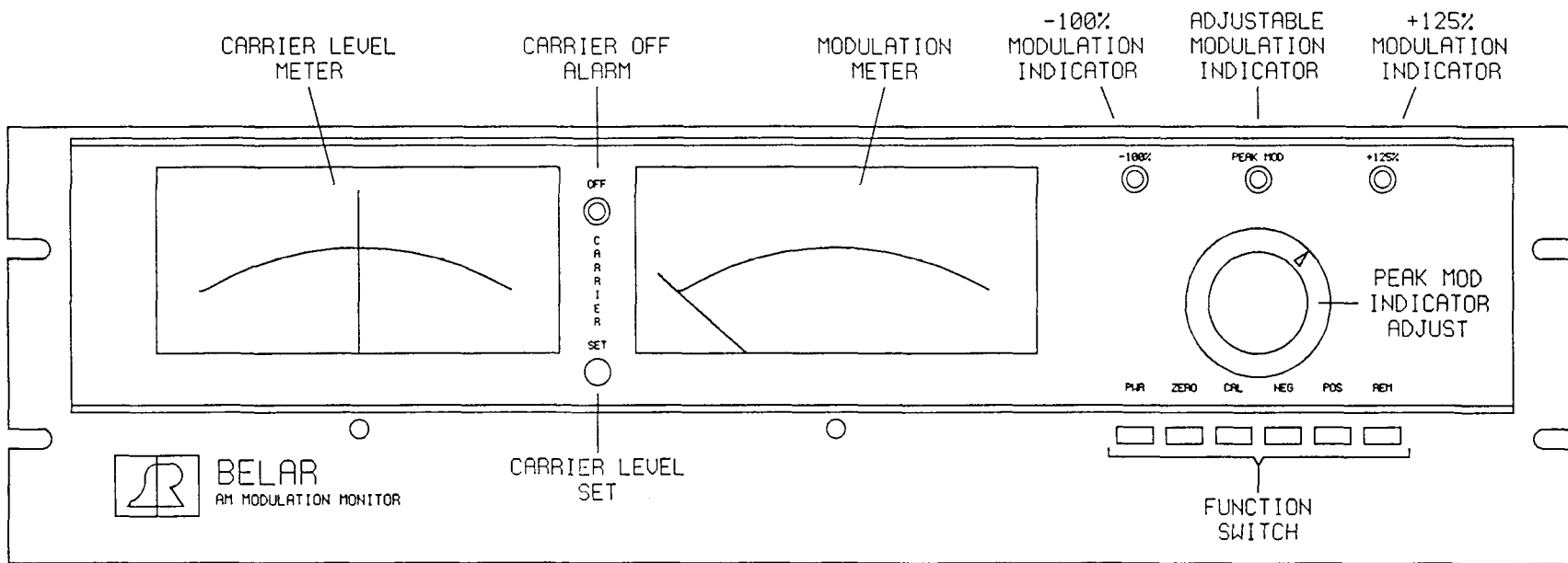

AMM-2B FRONT PANEL

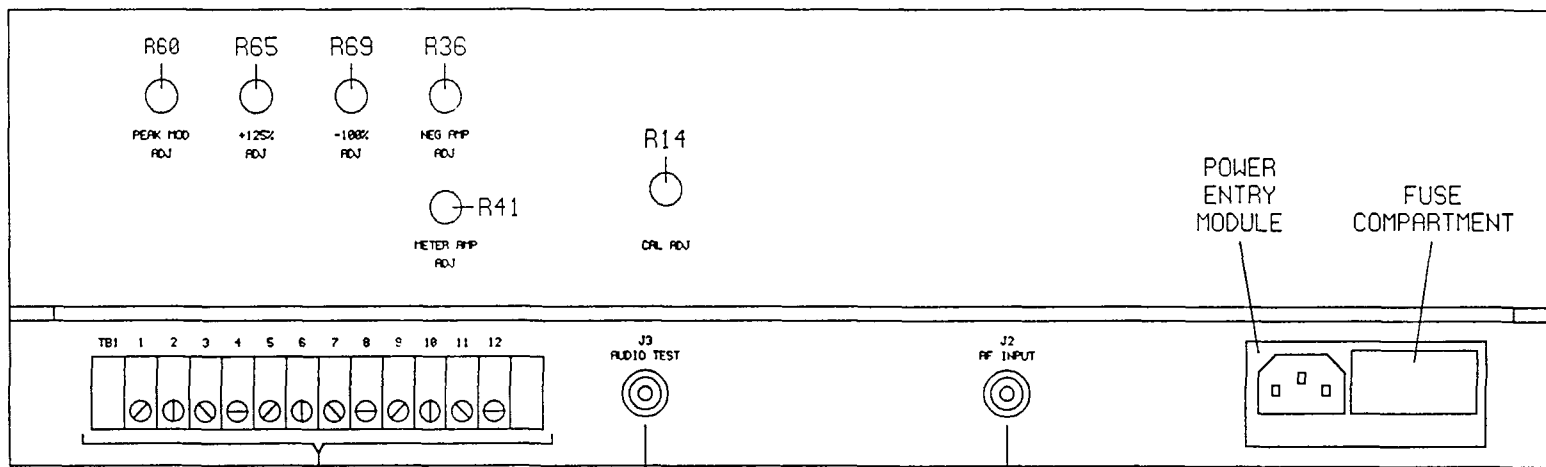

AMM-2B CHASSIS REAR VIEW  
BELAR ELECTRONICS



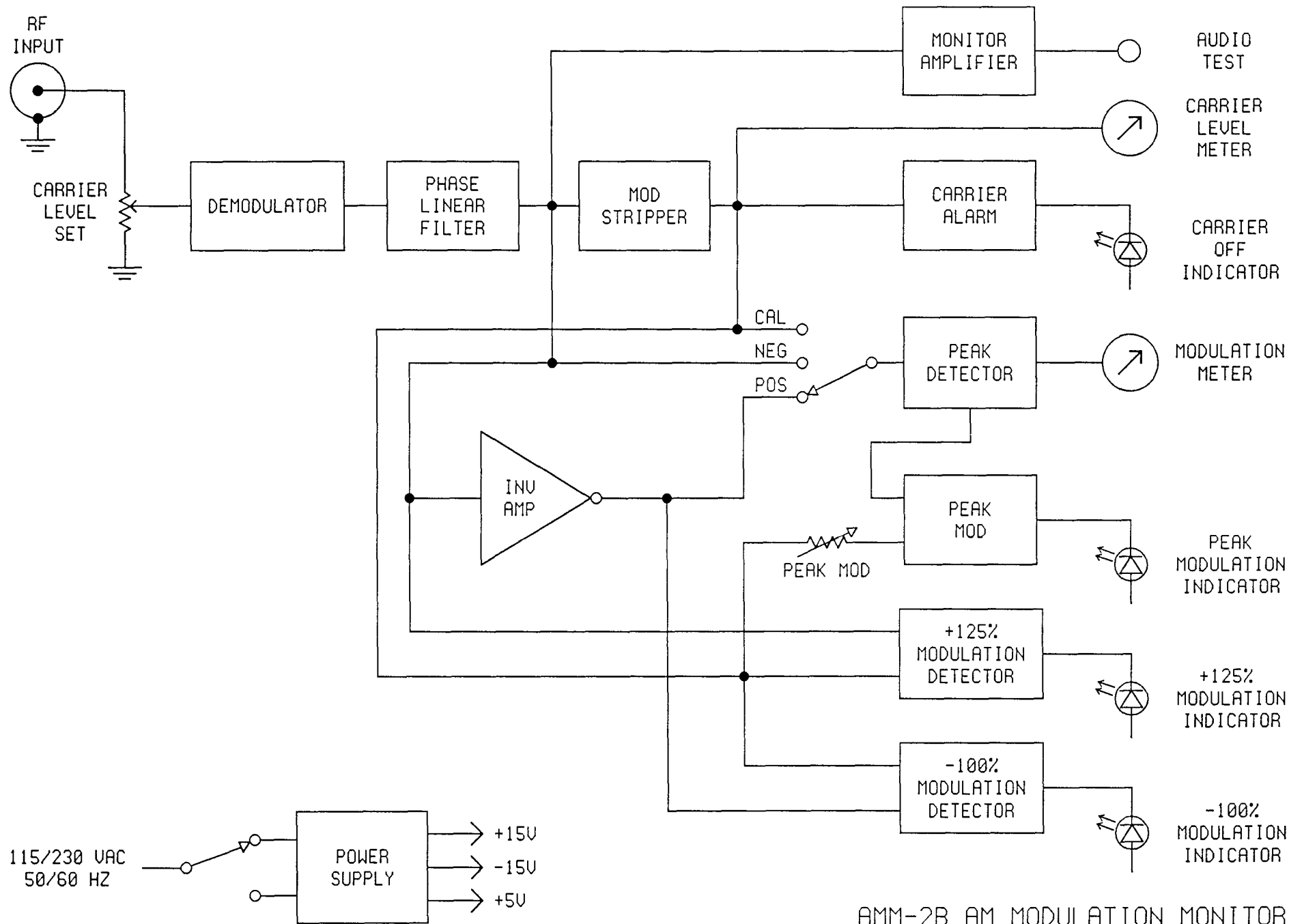

AMM-2B AM MODULATION MONITOR  
BLOCK DIAGRAM

The AMM-2B power supply has been modified due to the unavailability of the MC1468L I.C. (U4) on the A1 board.

BEGINNING WITH SERIAL NUMBER 134026; THE FOLLOWING MANUAL CHANGES APPLY:

1. Disregard the power supply adjustments in steps 3 and 4 of the "Modulation Meter Alignment Procedure" in the maintenace section of the manual.

2. The following parts are added to the chassis parts list:

C18,C19	C: FIXED CERAMIC 0.1uF 50V	0151-0006
U2	IC: 7915C	1826-0033
U3	IC: 7815C	1826-0031

3. The following parts are deleted from the A1 board parts list and part location table:

C10,C11	C: FIXED CERAMIC 0.001uF 1kV	0151-0002
C13,C14	C: FIXED CERAMIC 0.1uF 50V	0151-0006
Q4	TRANSISTOR: 2N3053	1850-0008
Q5	TRANSISTOR: 2N4037	1850-0011
R25 & R30	R: VAR COMP 100k	2100-0019
R26 & R31	R: METAL FILM 10k 2% 1/4W	0751-1032
R27,R28	R: METAL FILM 4.7 2% 1/2W	0771-47G2
R29 & R32	R: METAL FILM 51 2% 1/4W	0751-5102
U4	IC: MC1468L	1826-0002

All the affected drawings show both circuit versions.

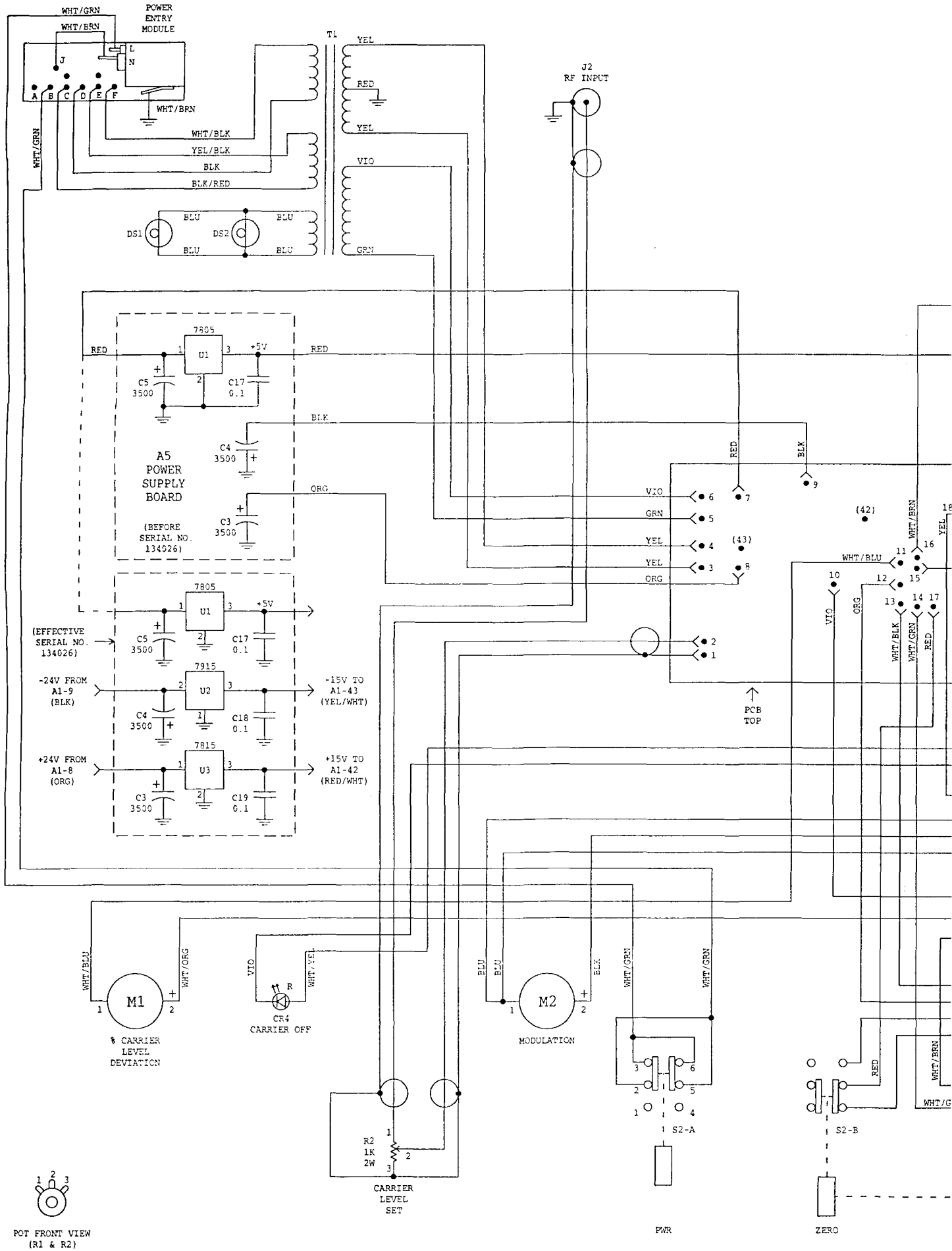

POT FRONT VIEW  
(R1 & R2)

PWR

ZERO

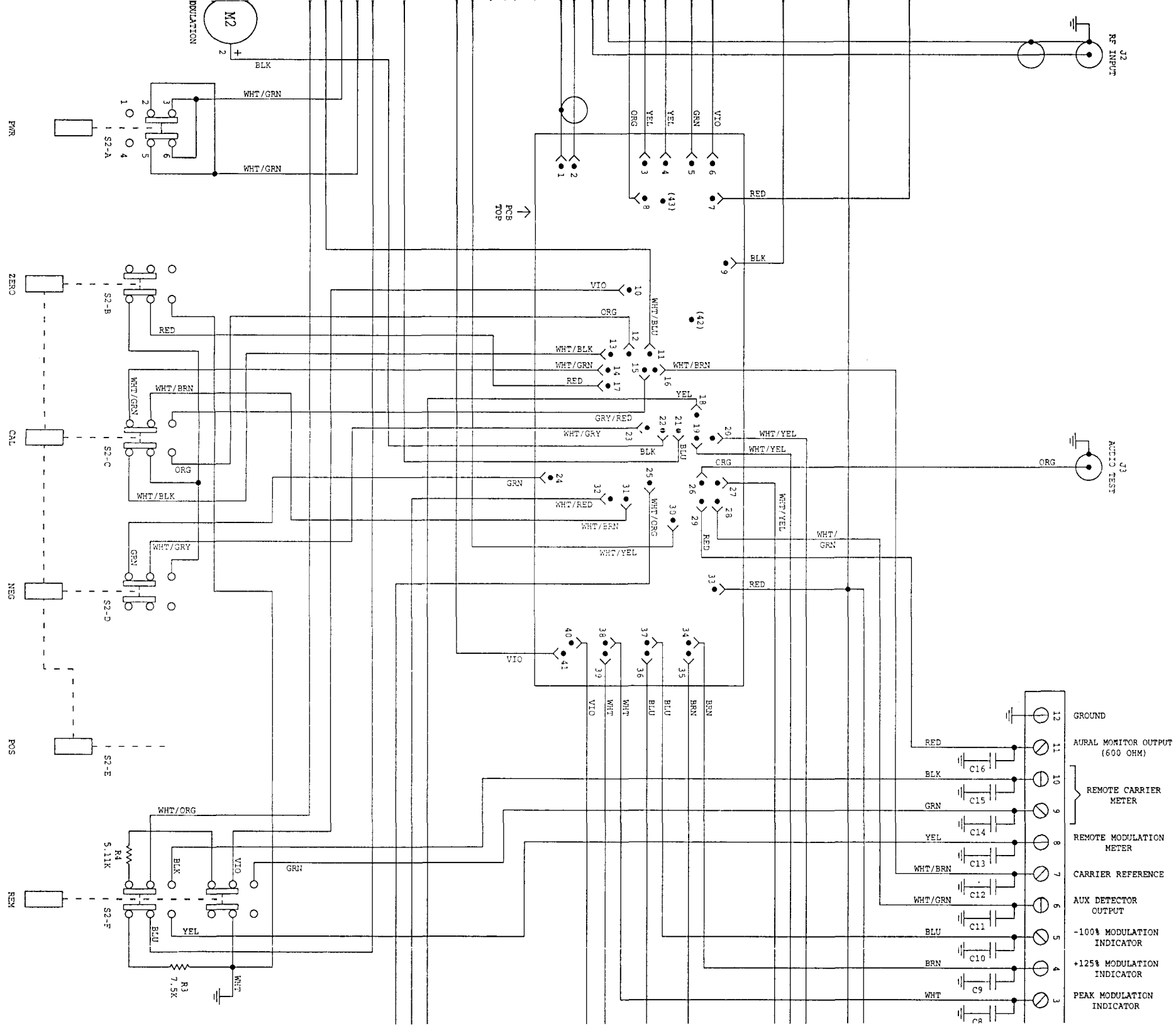

J2

J3

- 12 GROUND
- 11 AURAL MONITOR OUTPUT (600 OHM)
- 10 REMOTE CARRIER METER
- 9 REMOTE CARRIER METER
- 8 REMOTE MODULATION METER
- 7 CARRIER REFERENCE
- 6 AUX DETECTOR OUTPUT
- 5 -100% MODULATION INDICATOR
- 4 +125% MODULATION INDICATOR
- 3 PEAK MODULATION INDICATOR

PCB TOP

MODULATION

M2

PWR

ZERO

CAL

NEG

POS

REM

S2-A

S2-B

S2-C

S2-D

S2-E

S2-F

R4

R3

VIO  
GRN  
YEL  
YEL  
ORG

VIO  
ORG

WHT/BLK  
WHT/GRN  
RED

GRY/RED  
WHT/GRY  
BLK

GRN  
WHT/RED  
WHT/BRN

VIO  
WHT  
WHT  
BLU  
BLU  
BRN  
BRN

WHT/GRN  
WHT/GRN

WHT/BRN  
WHT/GRN  
WHT/BLK

WHT/GRY  
GRN

WHT/ORG  
BLK  
VIO  
GRN  
YEL  
BLU

1  
2

(43)

7

8

9

10

11

12

13

14

15

16

17

18

19

20

21

22

23

24

25

26

27

28

29

30

31

32

33

40

41

38

39

37

36

35

34

33

32

31

30

29

28

27

26

25

24

23

22

21

20

19

18

17

16

(42)

7

6

5

4

3

2

1

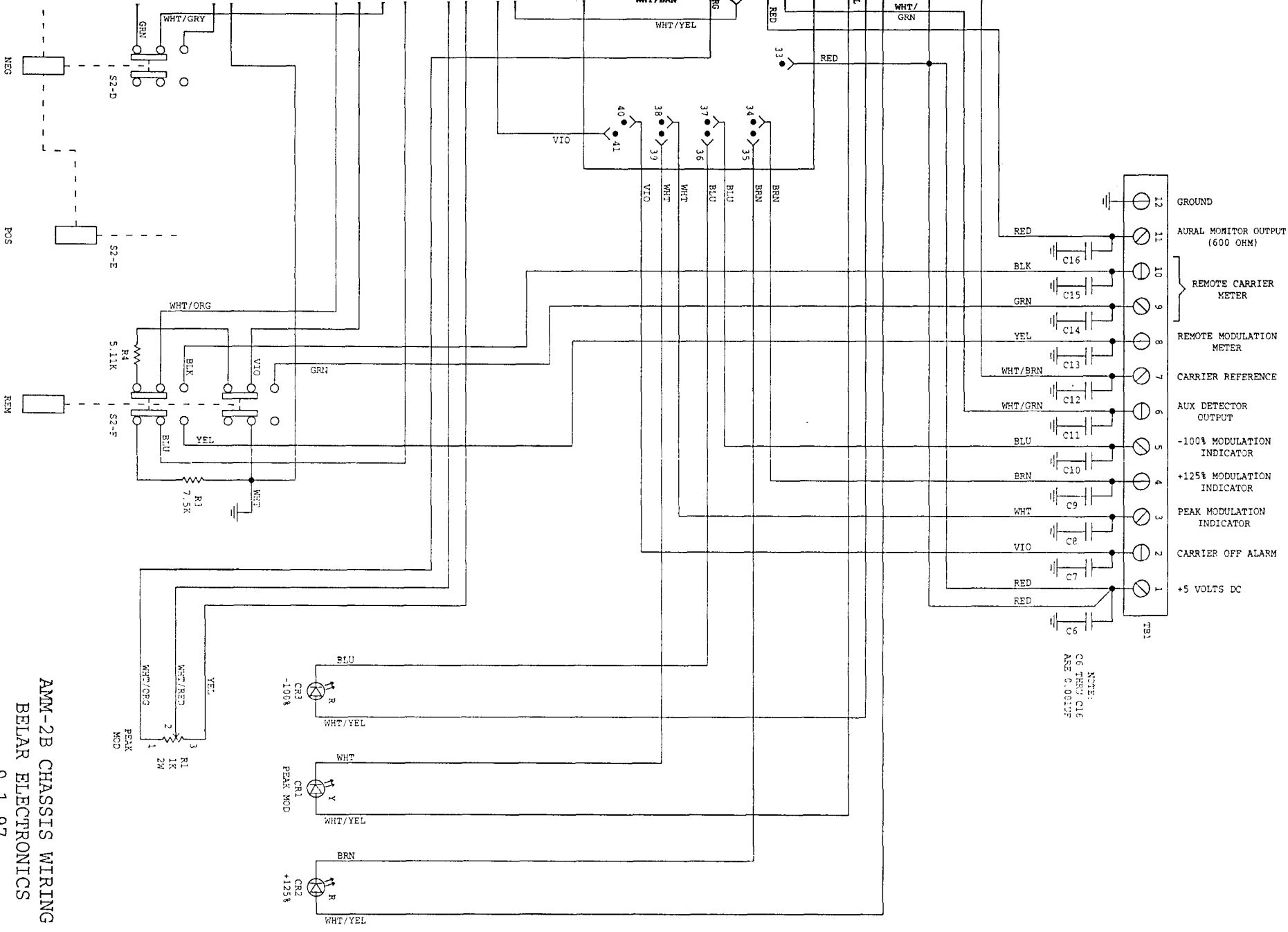

NOTE:  
 C6 THRU C16  
 ARE 0.0010F

AMM-2B CHASSIS WIRING  
 BELAR ELECTRONICS  
 9-1-97

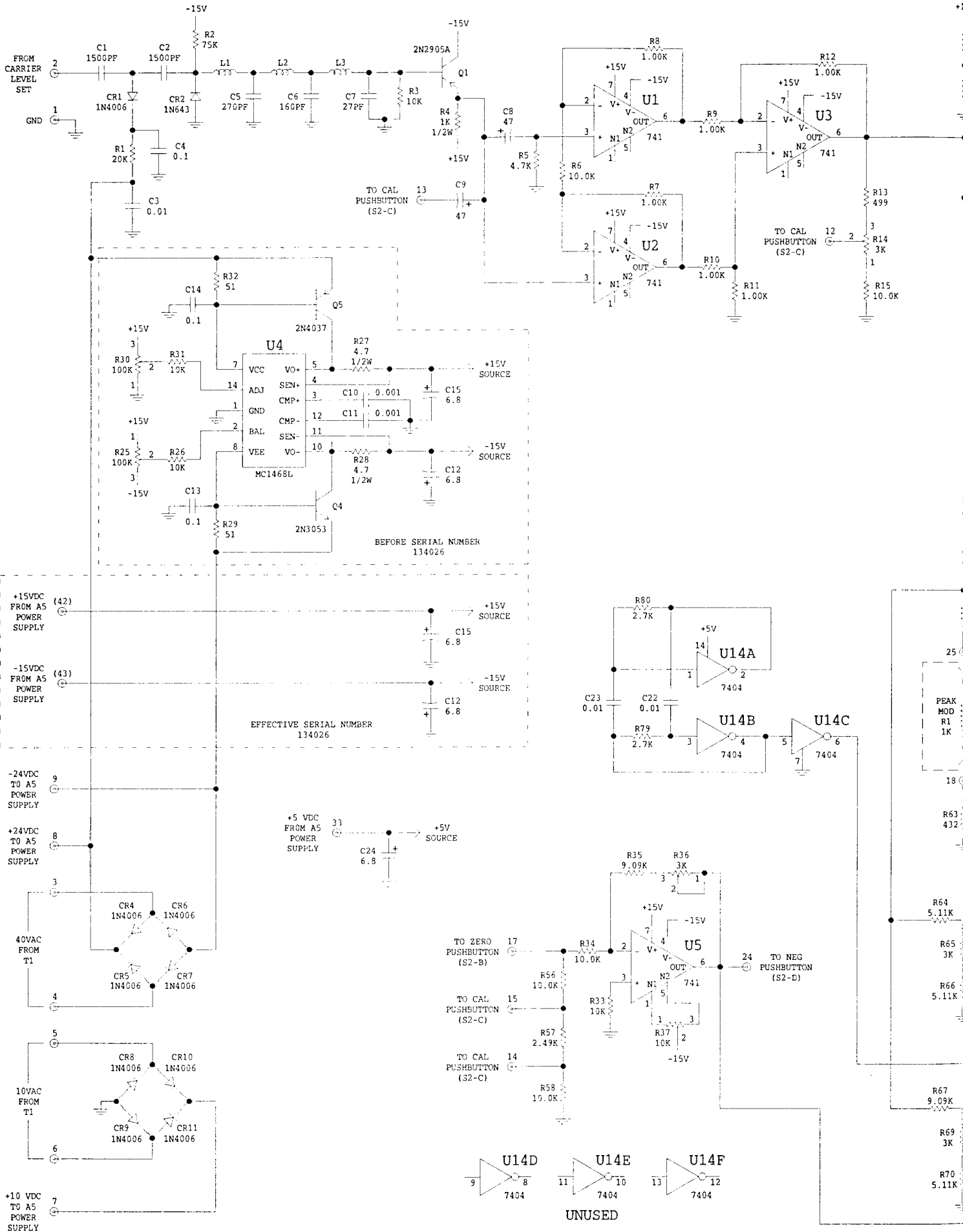

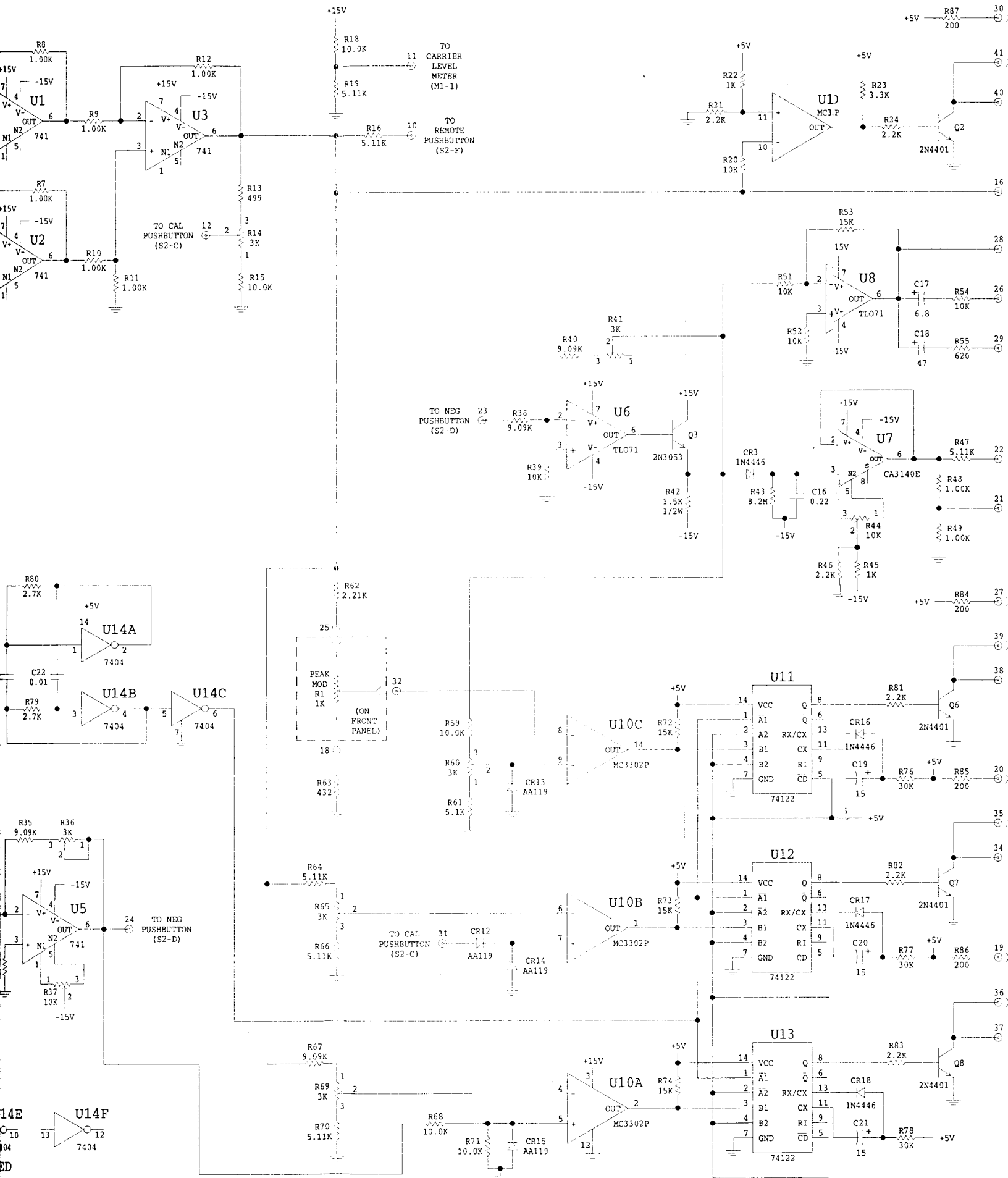

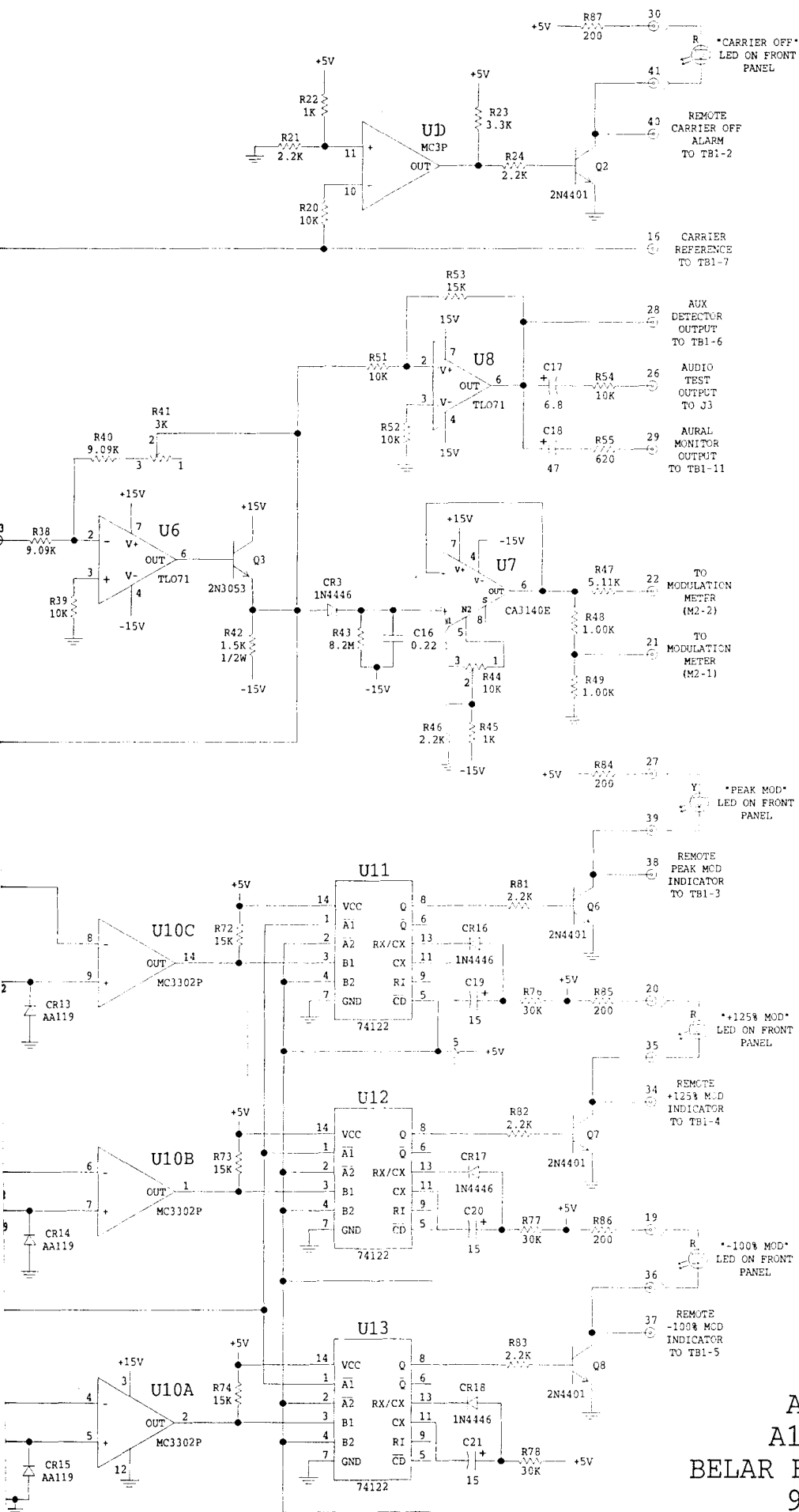

AMM-2B  
A1 BOARD  
BELAR ELECTRONICS  
9-1-97



## AMM-2B PARTS LISTS

### MAIN CHASSIS

Reference Designation	Description	Part Number
C1,C2	C: FIXED CERAMIC 0.01uF 1.4kV	(NOTE 2) 0151-0010
C3 thru C5	C: FIXED ELECT 3500uF 40V	(NOTE 1) 0180-0026
C6 thru C16	C: FIXED CERAMIC 0.001uF 1kV	0151-0002
C17	C: FIXED CERAMIC 0.1uF 50V	(NOTE 1) 0151-0006
CR1	LED: YELLOW MV5353	1910-0002
CR2 thru CR4	LED: RED MV5053	1910-0001
DS1,DS2	LAMP: 1847	2140-0005
--	SOCKET: LAMP	1450-0012
F1	FUSE: AGC 1/2A 250V (115 Vac line voltage)	2110-0001
	AGC 1/4A 250V (230 Vac Line voltage)	2110-0002
--	FUSEHOLDER:	(NOTE 2) 2110-0003
J1	JACK: POWER	(NOTE 2) 0360-0010
J2,J3	JACK: BNC	0360-0005
M1	METER: CARRIER LEVEL	1120-0013
M2	METER: MOD 0-133%	1120-0012
R1	R: VAR WW 1K 2W	(NOTE 3) 2100-0001
R2	R: VAR COMP 1k 2W	2100-0017
R3	R: METAL FILM 7.5k 2% 1/4W	0751-7522
R4	R: METAL FILM 5.11k 1%	0721-5111
--	R: FIXED NON-IND 56 20W	(NOTE 4) 0811-0021
S1	SWITCH: SLIDE 115/230V SELECTOR	(NOTE 2) 3102-0002
S2	SWITCH: PUSHBUTTON (6 button)	3101-0013
T1	TRANSFORMER: POWER	9100-0010
TB1	TERMINAL BLOCK: 12 SCREW	0360-0002
U1	IC: 7805C	1826-0014
--	LINE CORD	8120-0002

NOTE 1: Prior to serial number 133305 - C3 thru C5 were 1000uF 50v (0180-0002) and C17 was not used.

NOTE 2: Beginning serial number 133537 these parts are replaced by the 6J4 power entry module (0360-0020).

NOTE 3: Prior to serial number 133724 - R1 was a 500 ohm wire wound pot.

NOTE 4: Optional 50 ohm input termination.

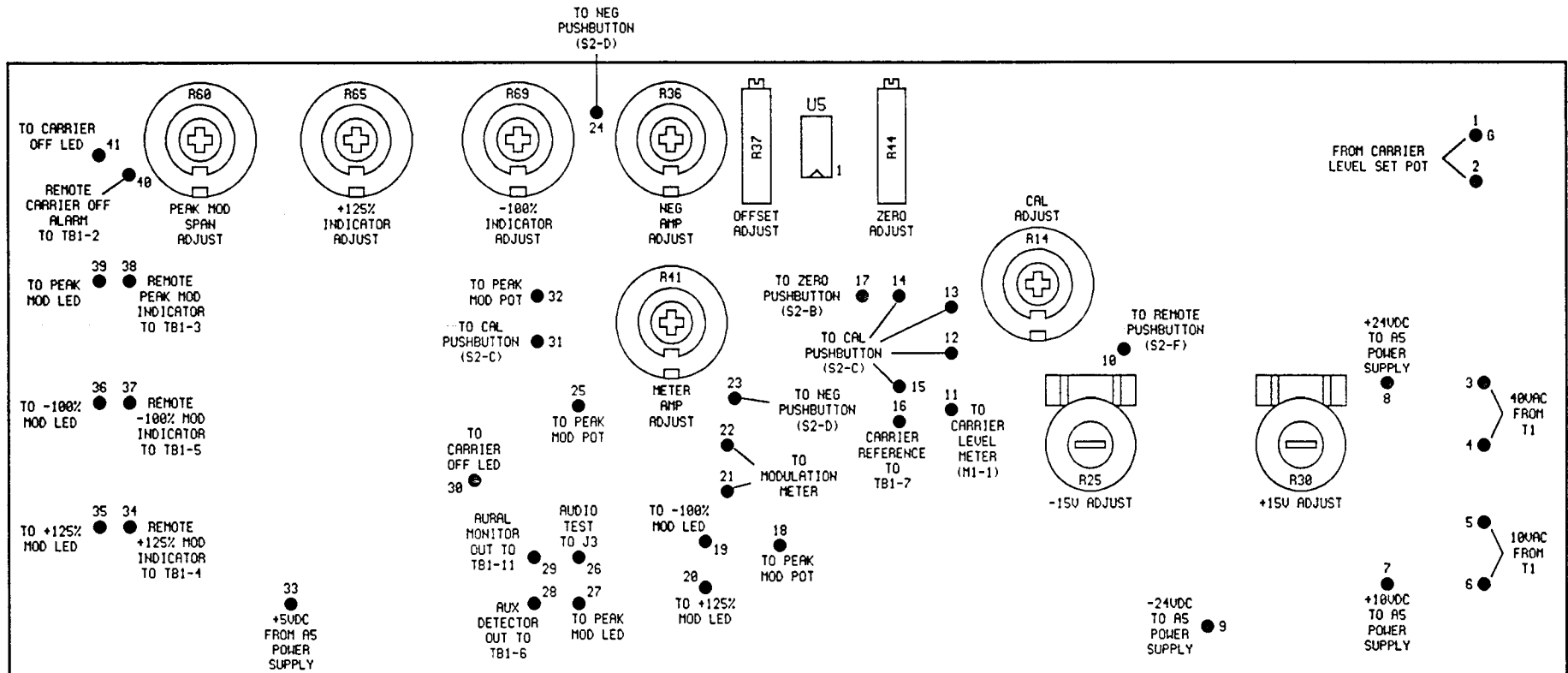

AMM-2B A1 BOARD  
 CONNECTIONS & ADJUSTMENTS  
 BELAR ELECTRONICS

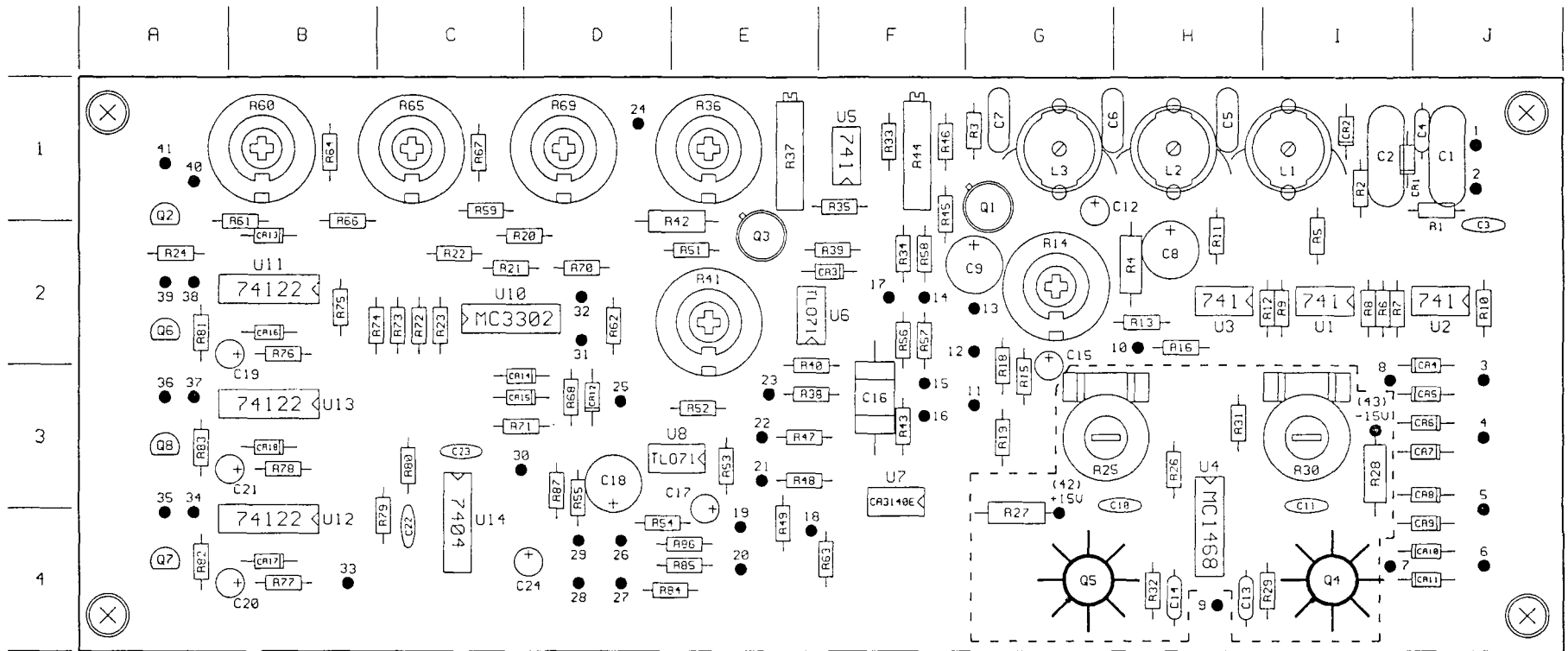

BEGINNING SERIAL NUMBER 134026, THE PARTS INSIDE THE LINE ARE OMITTED AND PINS 42 & 43 ARE ADDED.

AMM-2B A1 BOARD  
 COMPONENT LAYOUT  
 BELAR ELECTRONICS

AMM-2B A1 BOARD  
PART LOCATIONS

<u>Desig/Loc</u>	<u>Desig/Loc</u>	<u>Desig/Loc</u>	<u>Desig/Loc</u>	<u>Desig/Loc</u>	<u>Desig/Loc</u>	<u>Desig/Loc</u>	<u>Desig/Loc</u>	<u>Desig/Loc</u>	<u>Desig/Loc</u>
C1	J1	Q1	G1	R39	F2	R86	E4	29	D4
C2	I1	Q2	A1	R40	E2	R87	D3	30	C3
C3	J2	Q3	E2	R41	E2			31	D2
C4	J1	Q4	I4	R42	E1	U1	I2	32	D2
C5	H1	Q5	G4	R43	F3	U2	J2	33	B4
C6	G1	Q6	A2	R44	F1	U3	H2	34	A4
C7	G1	Q7	A4	R45	F1	U4	H4	35	A4
C8	H2	Q8	A3	R46	F1	U5	F1	36	A3
C9	G2			R47	E3	U6	E2	37	A3
C10	H3	R1	J1	R48	E3	U7	F3	38	A2
C11	I3	R2	I1	R49	E4	U8	E3	39	A2
C12	G1	R3	G1	R50	*	U9	*	40	A1
C13	H4	R4	H2	R51	E2	U10	C2	41	A1
C14	H4	R5	I2	R52	E3	U11	B2		
C15	G2	R6	I2	R53	E3	U12	B4		
C16	F3	R7	I2	R54	D4	U13	B3		
C17	E3	R8	I2	R55	D3	U14	C4		
C18	D3	R9	I2	R56	F2				
C19	A2	R10	J2	R57	F2				
C20	A4	R11	H2	R58	F2	<u>pins</u>			
C21	A3	R12	I2	R59	C1	1	J1		
C22	C4	R13	H2	R60	B1	2	J1		
C23	C3	R14	G2	R61	B1	3	J3		
C24	D4	R15	G3	R62	D2	4	J3		
		R16	H2	R63	F4	5	J3		
CR1	I1	R17	*	R64	B1	6	J4		
CR2	I1	R18	G2	R65	C1	7	I4		
CR3	F2	R19	G3	R66	B1	8	I3		
CR4	J2	R20	C2	R67	C1	9	H4		
CR5	J3	R21	C2	R68	D3	10	H2		
CR6	J3	R22	C2	R69	D1	11	G3		
CR7	J3	R23	C2	R70	D2	12	G2		
CR8	J3	R24	A2	R71	C3	13	G2		
CR9	J4	R25	G3	R72	C2	14	F2		
CR10	J4	R26	H3	R73	C2	15	F3		
CR11	J4	R27	G4	R74	B2	16	F3		
CR12	D3	R28	I3	R75	B2	17	F2		
CR13	B2	R29	I4	R76	B2	18	E4		
CR14	C3	R30	I3	R77	B4	19	E4		
CR15	C3	R31	H3	R78	B3	20	E4		
CR16	B2	R32	H4	R79	C4	21	E3		
CR17	B4	R33	F1	R80	C3	22	E3		
CR18	B3	R34	F2	R81	A2	23	E3		
		R35	F1	R82	A4	24	D1		
L1	I1	R36	E1	R83	A3	25	D3		
L2	H1	R37	E1	R84	D4	26	D4		
L3	G1	R38	E3	R85	E4	27	D4		
						28	D4		

\*not used

A1 BOARD AMM2B

Reference Designation	Description	Part Number
C1,C2	C: FIXED MICA 1500pF 5%	0141-1525
C3	C: FIXED CERAMIC 0.01uF 100V	0151-0003
C4	C: FIXED CERAMIC 0.1uF 50V	0151-0006
C5	C: FIXED MICA 270pF 5%	0140-2715
C6	C: FIXED MICA 160pF 5%	0140-1615
C7	C: FIXED MICA 27pF 5%	0140-2705
C8,C9	C: FIXED ELEC 47uF 63V	0180-0017
C10,C11	C: FIXED CERAMIC 0.001uF 1kV	0151-0002
C12	C: FIXED TANT 6.8uF 25V	0185-0002
C13,C14	C: FIXED CERAMIC 0.1uF 50V	0151-0006
C15	C: FIXED TANT 6.8uF 25V	0185-0002
C16	C: FIXED FILM 0.22uF 10% 80V	0120-2241
C17	C: FIXED TANT 6.8uF 25V	0185-0002
C18	C: FIXED ELEC 47uF 63V	0180-0017
C19 thru C21	C: FIXED TANT 15uF 15V	0185-0003
C22,C23	C: FIXED CERAMIC 0.01uF 100V	0151-0003
C24	C: FIXED TANT 6.8uF 25V	0185-0002
CR1	DIODE: 1N4006	1900-0016
CR2	DIODE: 1N643	1900-0017
CR3	DIODE: 1N4446	1900-0002
CR4 thru CR11	DIODE: 1N4006	1900-0016
CR12 thru CR15	DIODE: AA119	1900-0001
CR16 thru CR18	DIODE: 1N4446	1900-0002
L1	INDUCTOR:	Belar
L2	INDUCTOR:	Belar
L3	INDUCTOR:	Belar
Q1	TRANSISTOR: 2N2905A	1850-0030
Q2	TRANSISTOR: 2N4401	1850-0028
Q3,Q4	TRANSISTOR: 2N3053	1850-0008
Q5	TRANSISTOR: 2N4037	1850-0011
Q6 thru Q8	TRANSISTOR: 2N4401	1850-0028
R1	R: METAL FILM 20k 2% 1/4W	0751-2032
R2	R: METAL FILM 75k 2% 1/4W	0751-7532
R3	R: METAL FILM 10k 2% 1/4W	0751-1032
R4	R: METAL FILM 1k 2% 1/2W	0771-1022
R5	R: METAL FILM 4.7k 2% 1/4W	0751-4722
R6	R: METAL FILM 10.0k 1%	0721-1002
R7 THRU R12	R: METAL FILM 1.00k 1%	0721-1001
R13	R: METAL FILM 499 1%	0721-4990
R14	R: VAR WW 3k 2W	2100-0005
R15	R: METAL FILM 10.0k 1%	0721-1002
R16	R: METAL FILM 5.11k 1%	0721-5111
R17	not used	
R18	R: METAL FILM 10.0k 1%	0721-1002
R19	R: METAL FILM 5.11k 1%	0721-5111
R20	R: METAL FILM 10k 2% 1/4W	0751-1032

A1 BOARD AMM-2B CONT.

Reference Designation	Description	Part Number
R21	R: METAL FILM 2.2k 2% 1/4W	0751-2222
R22	R: METAL FILM 1k 2% 1/4W	0751-1022
R23	R: METAL FILM 3.3k 2% 1/4W	0751-3322
R24	R: METAL FILM 2.2k 2% 1/4W	0751-2222
R25	R: VAR COMP 100k	2100-0019
R26	R: METAL FILM 10k 2% 1/4W	0751-1032
R27, R28	R: METAL FILM 4.7 2% 1/2W	0771-47G2
R29	R: METAL FILM 51 2% 1/4W	0751-5102
R30	R: VAR COMP 100k	2100-0019
R31	R: METAL FILM 10k 2% 1/4W	0751-1032
R32	R: METAL FILM 51 2% 1/4W	0751-5102
R33	R: METAL FILM 10k 2% 1/4W	0751-1032
R34	R: METAL FILM 10.0k 1%	0721-1002
R35	R: METAL FILM 9.09k 1%	0721-9091
R36	R: VAR WW 3k 2W	2100-0005
R37	R: VAR COMP 10k, 10 TURN	2100-0018
R38	R: METAL FILM 9.09k 1%	0721-9091
R39	R: METAL FILM 10k 2% 1/4W	0751-1032
R40	R: METAL FILM 9.09k 1%	0721-9091
R41	R: VAR WW 3k 2W	2100-0005
R42	R: METAL FILM 1.5k 2% 1/2W	0771-1522
R43	R: FIXED CARBON 8.2M 5% 1/4W	0683-8255
R44	R: VAR COMP 10k, 10 TURN	2100-0018
R45	R: METAL FILM 1k 2% 1/4W	0751-1022
R46	R: METAL FILM 2.2k 2% 1/4W	0751-2222
R47	R: METAL FILM 5.11k 1%	0721-5111
R48, R49	R: METAL FILM 1.00k 1%	0721-1001
R50	not used	
R51, R52	R: METAL FILM 10k 2% 1/4W	0751-1032
R53	R: METAL FILM 15k 2% 1/4W	0751-1532
R54	R: METAL FILM 10k 2% 1/4W	0751-1032
R55	R: METAL FILM 620 2% 1/4W	0751-6212
R56	R: METAL FILM 10.0k 1%	0721-1002
R57	R: METAL FILM 2.49k 1%	0721-2491
R58, R59	R: METAL FILM 10.0k 1%	0721-1002
R60	R: VAR WW 3k 2W (NOTE 1)	2100-0005
R61	R: METAL FILM 5.1k 2% 1/4W	0751-5122
R62	R: METAL FILM 2.21k 1% (NOTE 2)	0721-2211
R63	R: METAL FILM 432 1% (NOTE 2)	0721-4320
R64	R: METAL FILM 5.11k 1%	0721-5111
R65	R: VAR WW 3k 2W	2100-0005
R66	R: METAL FILM 5.11k 1%	0721-5111
R67	R: METAL FILM 9.09k 1%	0721-9091
R68	R: METAL FILM 10.0k 1%	0721-1002

NOTE 1: Prior to serial number 133517; R60 was a 1k WW 2W pot (2100-0012).

NOTE 2: Prior to serial number 133724; R62 was a 1.10k resistor and R63 was a 221 ohm resistor.

A1 BOARD AMM-2B CONT.

Reference Designation	Description	Part Number
R69	R: VAR WW 3k 2W	2100-0005
R70	R: METAL FILM 5.11k 1%	0721-5111
R71	R: METAL FILM 10.0k 1%	0721-1002
R72 thru R74	R: METAL FILM 15k 2% 1/4W	0751-1532
R75	R: METAL FILM 1k 2% 1/4W	0751-1022
R76 thru R78	R: METAL FILM 30k 2% 1/4W	0751-3032
R79,R80	R: METAL FILM 2.7k 2% 1/4W	0751-2722
R81 thru R83	R: METAL FILM 2.2k 2% 1/4W	0751-2222
R84 thru R87	R: METAL FILM 200 2% 1/4W	0751-2012
U1 thru U3	IC: MC1741	1826-0006
U4	IC: MC1468L	1826-0002
U5	IC: MC1741	1826-0006
U6	IC: TL071	1826-0004
U7	IC: CA3140E	1826-0001
U8	IC: TL071	1826-0004
U9	not used	
U10	IC: MC3302	1826-0005
U11 thru U13	IC: 74122	1821-0015
U14	IC: 7404	1821-0003

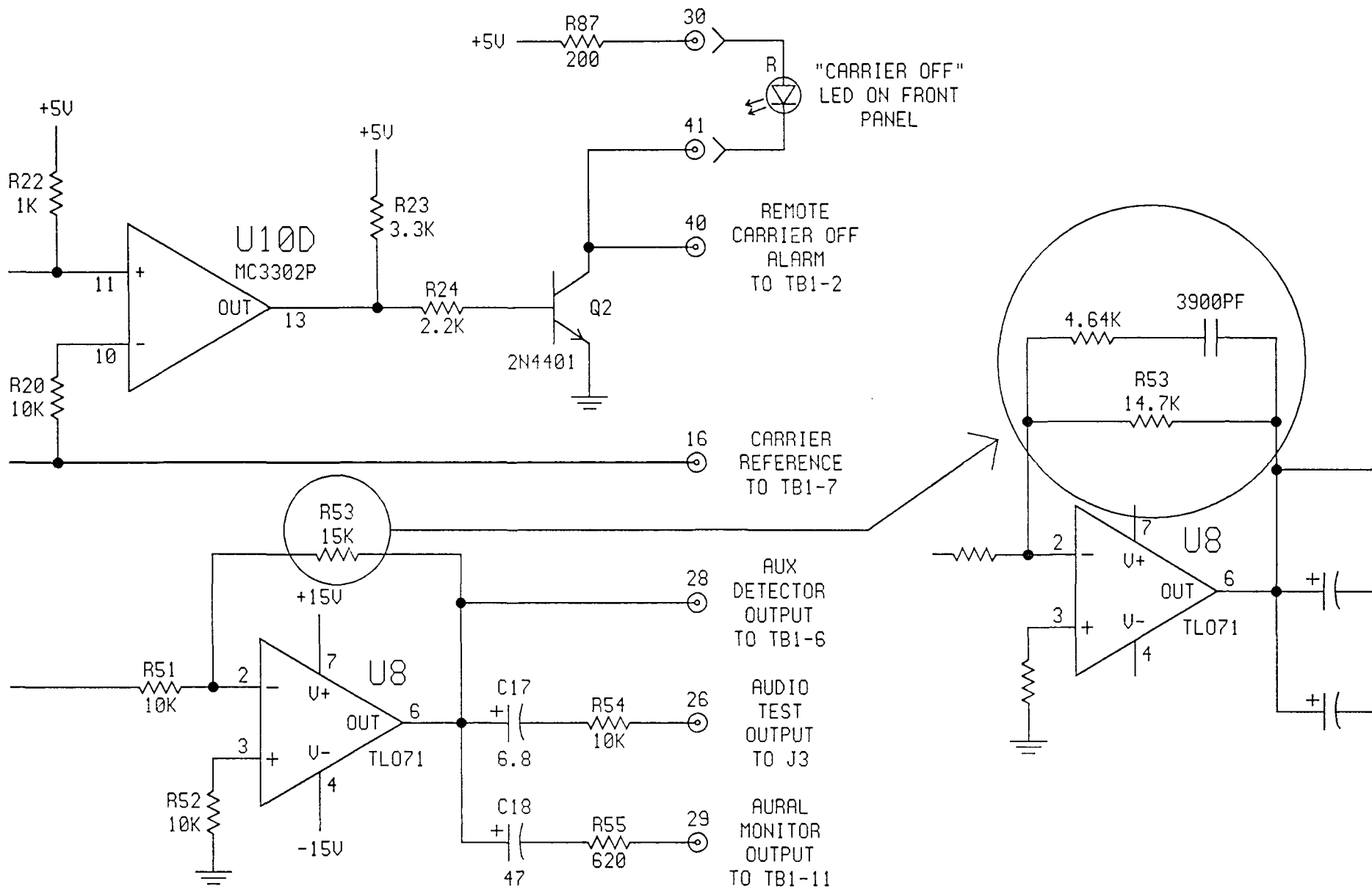

AMM-2A/2B A1 BOARD  
 NRSC DE-EMPHASIS MODIFICATION  
 BELAR ELECTRONICS



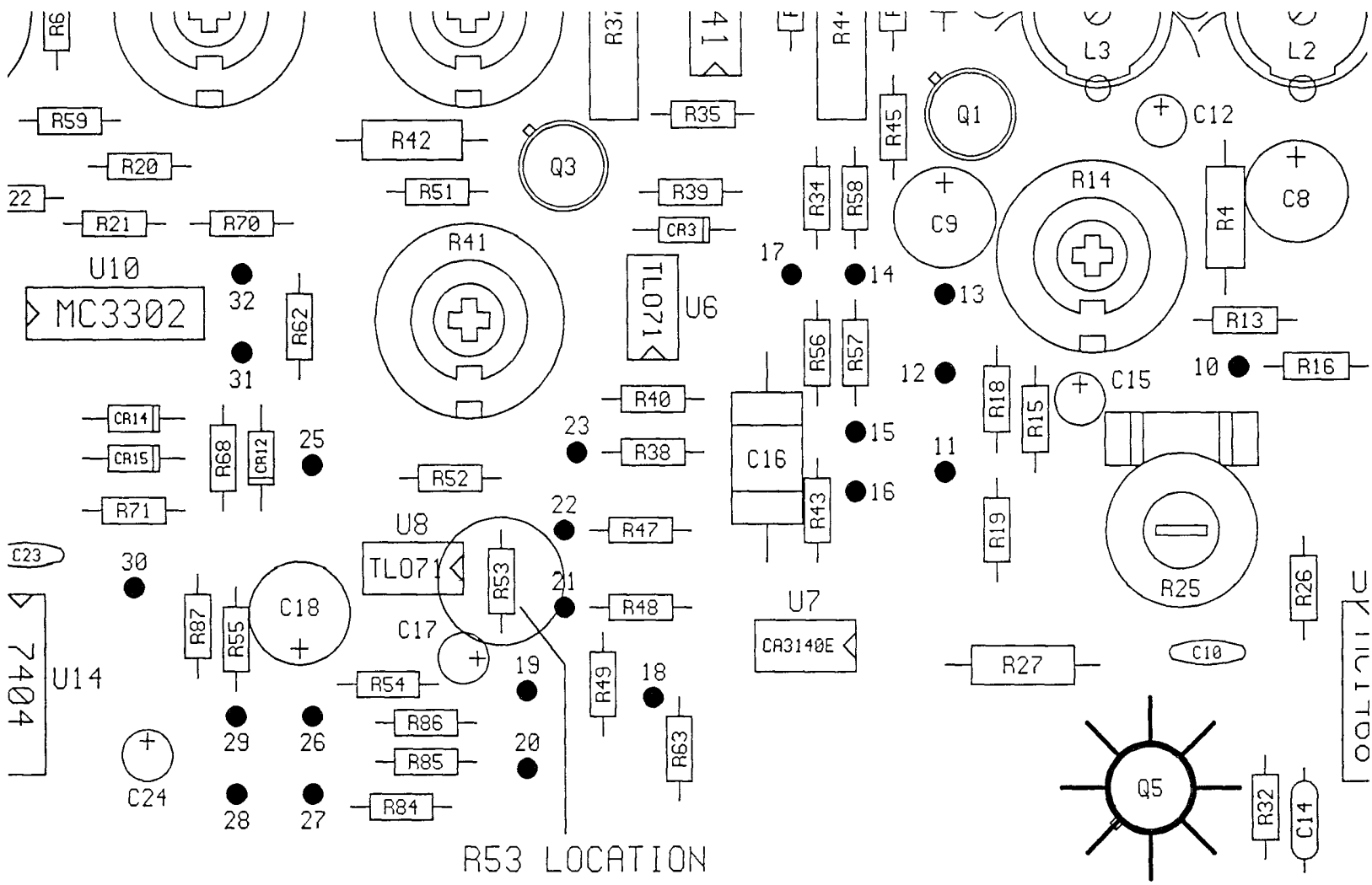

AMM-2A/2B A1 BOARD  
 NRSC DE-EMPHASIS MODIFICATION  
 BELAR ELECTRONICS

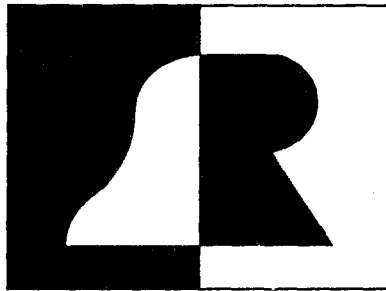

**BELAR**  
**ELECTRONICS LABORATORY, INC.**

119 LANCASTER AVENUE  
P.O. BOX 76  
DEVON, PA 19333-0076 USA  
(610) 687-5550 • FAX (610) 687-2686  
sales@belar.com • <http://www.belar.com/>