



BELAR

Broadcast Equipment

FMM-1

FM MONITOR

WARRANTY AND ASSISTANCE

All Belar products are warranted against defects in materials and workmanship. This warranty applies for one year from the date of delivery, or, in the case of certain major components listed in the instruction manual, for the specified period. Belar will repair or replace products which prove to be defective during the warranty period provided that they are returned to Belar. No other warranty is expressed or implied. Belar is not liable for consequential damages.

For any assistance, contact either your Belar Sales Representative or Customer Engineering Service at the Belar factory.

Broadcast Equipment

Instructions

FMM-1

FM Monitor



BELAR ELECTRONICS LABORATORY, INC.

TABLE OF CONTENTS

SECTION 1	PAGE	SECTION 5	PAGE
GENERAL INFORMATION	3	MAINTENANCE	15
1-1 GENERAL DESCRIPTION	3	5-1 INTRODUCTION	15
1-2 PHYSICAL DESCRIPTION	3	5-2 PERFORMANCE CHECKS	15
1-3 ELECTRICAL DESCRIPTION	4	5-2-1 Power and Oven Check	15
1-4 ELECTRICAL SPECIFICATIONS	4	5-2-2 Oscillator Level Check	15
1-5 MECHANICAL SPECIFICATIONS	5	5-2-3 Frequency Meter Amplifier Check	15
1-6 INSTRUMENT IDENTIFICATION	5	5-2-4 Freq Meter Discriminator Check	15
1-7 ACCESSORIES	5	5-2-5 Mod Meter Amplifier Zero Check	15
 		5-2-6 Modulation Calibrator Check	15
SECTION 2	PAGE	5-2-7 Remote Meter Switch Check	15
INSTALLATION	7	5-2-8 Percent Mod Potentiometer Check	15
2-1 INITIAL INSPECTION	7	5-2-9 Modulation Polarity Check	15
2-2 CLAIMS	7	5-2-10 Carrier Level Check	15
2-3 REPACKING FOR SHIPMENTS	7	5-2-11 Operate Check	15
2-4 PREPARATION FOR USE	7	5-2-12 De-emphasis Switch Check	16
 		5-3 ADJUSTMENTS, CALIBRATION & TROUBLESHOOTING	16
SECTION 3	PAGE	5-3-1 Power & Oven	16
OPERATIONS	9	5-3-2 Oscillator Level	16
3-1 INITIAL OPERATION	9	5-3-3 Frequency Meter Amplifier	16
3-2 NORMAL OPERATION	9	5-3-4 Freq Meter Discriminator	16
3-3 LOCAL OSCILLATOR FREQUENCY CALIBRATION	9	5-3-5 Mod Meter Amplifier Zero	16
3-4 TRANSMITTER MEASUREMENTS	9	5-3-6 Modulation Calibrator	17
 		5-3-7 Remote Meter Switch	17
SECTION 4	PAGE	5-3-8 Percent Mod Potentiometer	17
PRINCIPLES OF OPERATIONS	11	5-3-9 Modulation Polarity	17
4-1 BLOCK DIAGRAM DESCRIPTION	11	5-3-10 Carrier Level	17
4-2 DETAILED CIRCUIT DESCRIPTION	11	5-3-11 Operate	17
4-2-1 Oscillator, Tripler & Mixer Circuit	11	5-3-12 De-emphasis Switch	17
4-2-2 Oscillator, Counter Discriminator & Amplifier Circuits	13	 	
4-2-3 Amplifier, Metering & Flasher Circuits	14	SECTION 6	PAGE
 		REPLACEABLE PARTS	23
 		6-1 INTRODUCTION	23
 		6-2 ORDERING INFORMATION	23
 		SECTION 7	PAGE
 		SCHEMATICS	29

LIST OF ILLUSTRATIONS

1-1 FMM-1 FREQUENCY AND MODULATION MONITOR	3	5-3 A3 CARD	20
1-2 FRONT PANEL VIEW	4	5-4 TOP VIEW, COVER OFF	21
1-3 REAR PANEL VIEW	4	5-5 BOTTOM VIEW, COVER OFF	22
1-4 MECHANICAL DIMENSIONS	5	7-1 OSCILLATOR, TRIPLER & MIXER CARD A1, SCHEMATIC	30
2-1 REAR PANEL CONNECTIONS	6	7-2 OSCILLATOR, COUNTER & AMPLIFIER CARD A2, SCHEMATIC	31
3-1 OPERATING CONTROLS	8	7-3 AMPLIFIER, METERING & FLASHER CARD A3, SCHEMATIC	33
4-1 BLOCK DIAGRAM	10	7-4 FREQUENCY & MODULATION MONITOR CHASSIS, SCHEMATIC	35
4-2 WAVEFORMS	12		
5-1 A1 CARD	18		
5-2 A2 CARD	19		

SECTION 1 GENERAL INFORMATION

1-1 GENERAL DESCRIPTION

The Belar FMM-1 FM Frequency and Modulation Monitor, Figure 1-1, [FCC Type Approval Number 3-129] is a wideband, all solid state FM monitor designed to meet the Federal Communications Commission requirements for measuring the center frequency and total modulation characteristics of monaural as well as multiplexed FM transmitters having a center frequency range of 88 to 108 MHz. In addition, the FMM-1 may be used as a low distortion and low noise FM demodulator for driving audio monitor amplifiers and the companion Belar FMS-1 Stereo Frequency and Modulation Monitor and one or more SCM-1 SCA Frequency and Modulation Monitors. The FMM-1 incorporates a deviation type modulation calibrator to insure the accuracy of the modulation readings at any time.

1-2 PHYSICAL DESCRIPTION

The FMM-1, Figure 1-2, is constructed on a standard 5¼ x 19 inch rack mount. Seldom used controls and test points are located under the hinged front cover bar. Factory adjustments are located within the shielded compartments of the monitor. The AC power input, RF input, and monitor outputs are located at the rear of the FMM-1 chassis on individual connectors or on rear terminal blocks as shown in Figure 1-3. The FMM-1 is completely solid state utilizing all silicon transistors for long, trouble-free life. The individual circuits are constructed on military grade, glass-epoxy, plated printed circuit boards. High reliability industrial and military grade components are used throughout.



Figure 1-1

1-3 ELECTRICAL DESCRIPTION

The FMM-1 is a solid state, low sensitivity, crystal controlled, superheterodyne FM receiver incorporating a highly linear and stable pulse counting discriminator that measures the center frequency deviation and demodulates the FM transmission. Various metering and testing provisions are contained within the monitor to measure transmitter output characteristics. These provisions include a center frequency deviation meter; a peak reading total modulation meter, switchable to either positive or negative modulation polarity; a peak modulation light, independent of modulation polarity, that responds to both positive and negative directions; metering circuits to set the incoming RF level and to standardize the center frequency deviation meter with the calibrating oscillator; a deviation type modulation calibrator to standardize the modulation level. Outputs obtained from the monitor include a monaural output for aural monitoring, a distortion meter test output [both monaural output and distortion meter output have front panel switched de-emphasis], a wideband test output, four wideband outputs for driving associated multiplex demodulators, an AM noise diode output, and an incidental AM noise diode output. FCC Type Approved remote metering of the FMM-1 may be externally provided for the

center frequency deviation meter, modulation meter, and peak light.

1-4 ELECTRICAL SPECIFICATIONS

- RF Input Sensitivity 0.2 to 10 volts RMS.
- RF Input Impedance 50 ohms.
- RF Frequency Range 88-108 MHz.
- Deviation Meter Range ± 3 kHz.
- Modulation Meter Range 133% [100% at 75 kHz].
- Modulation Calibrator 100% at 75 kHz.
- Modulation Meter Accuracy Better than 5% over entire scale.
- Peak Modulation Indicator 50 to 120%.
- Frequency response ± 0.1 db, 50-75,000 Hz,
3 db down at 180 kHz.
- Distortion 0.1% max. 50-75,000 Hz.
- Signal-to-Noise Ratio 75 db with 75 usec de-emphasis.
- Outputs 4 wideband isolated outputs to drive the FMS-1 stereo unit and one or more SCM-1 SCA units, wideband test output, distortion meter output, aural monitoring output, AM noise output, and Incidental AM noise output.
- Remote Metering Both carrier deviation and modulation meters may be remotely metered, 5000 ohms external loop resistance.

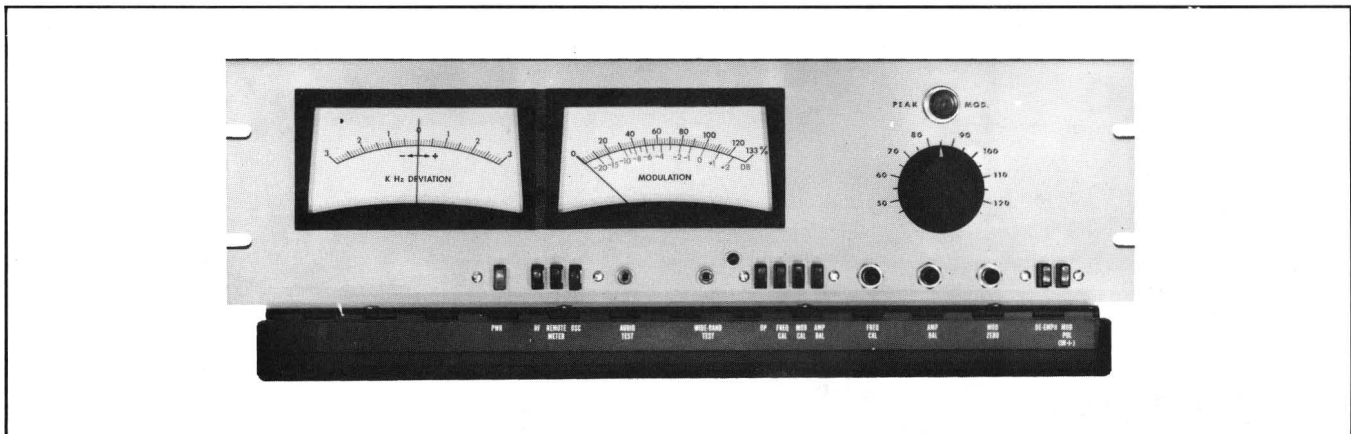

Figure 1-2

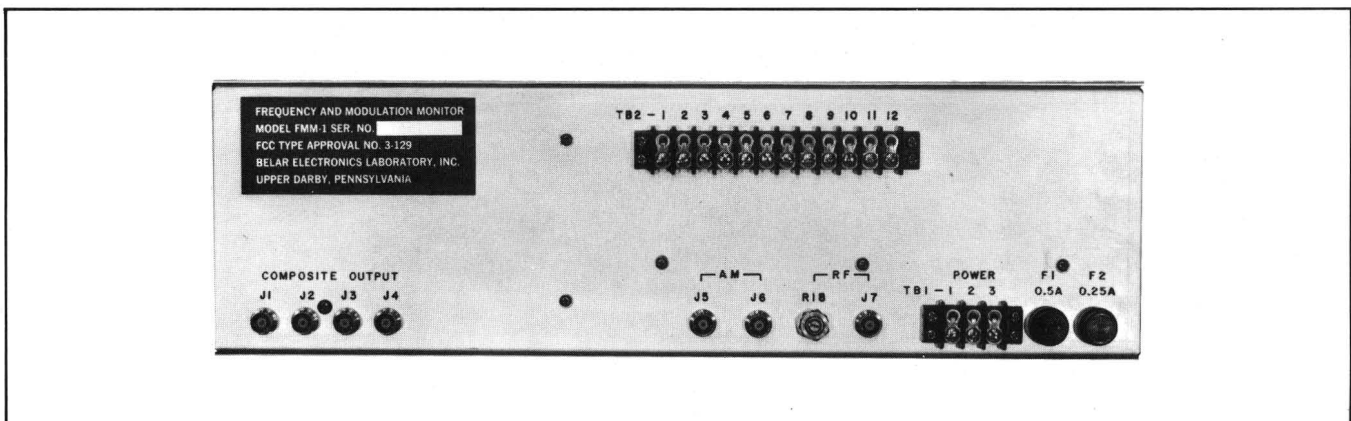

Figure 1-3

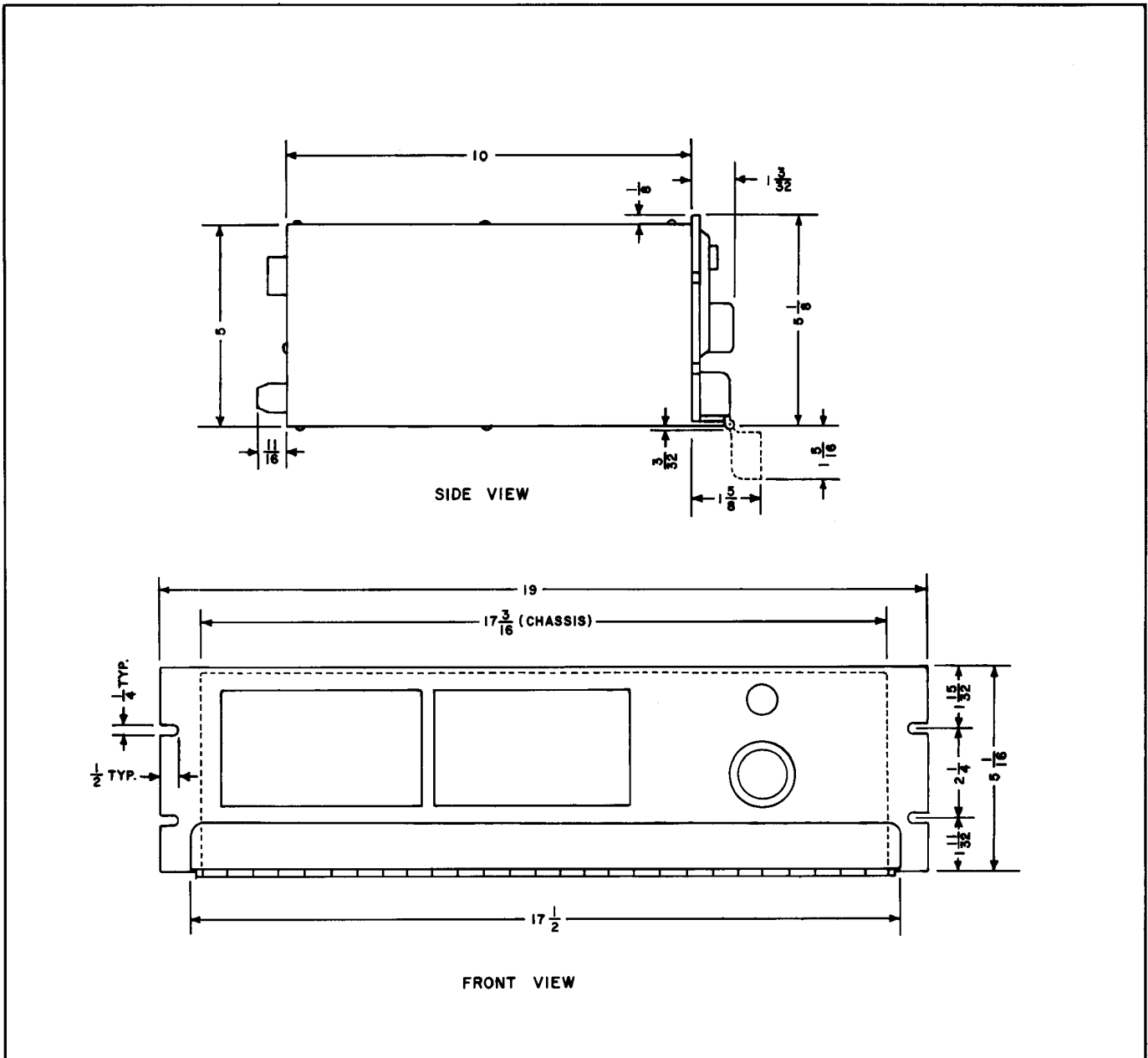

Figure 1-4

1-5 MECHANICAL SPECIFICATIONS

Dimensions	.5 $\frac{1}{4}$ x 19 x 11 $\frac{7}{8}$ inches overall
Detailed Dimensions	Figure 1-4
Net Weight	.15 pounds
Shipping Weight	.19 pounds

1-6 INSTRUMENT IDENTIFICATION

The instrument is identified by the model number and a six digit serial number. The model number and serial number appear on a plate located on the rear panel, Figure 1-3. All correspondence to your Belar representative or to the Belar factory in regard to the instrument should reference the

model number and complete serial number.

1-7 ACCESSORIES

The Belar FMM-1 FM Frequency and Modulation Monitor may be used for the remote monitoring of an FM transmitter with either the Belar MP-1 Remote Meter Panel or the Belar RFA-1 RF Amplifier. The MP-1 Meter Panel contains a peak indicator lamp, a carrier frequency deviation meter and a modulation meter, both designed for 5000 ohms loop resistance. The RFA-1 RF Amplifier provides pre-amplification and selectivity to permit direct off-air monitoring with the FMM-1.

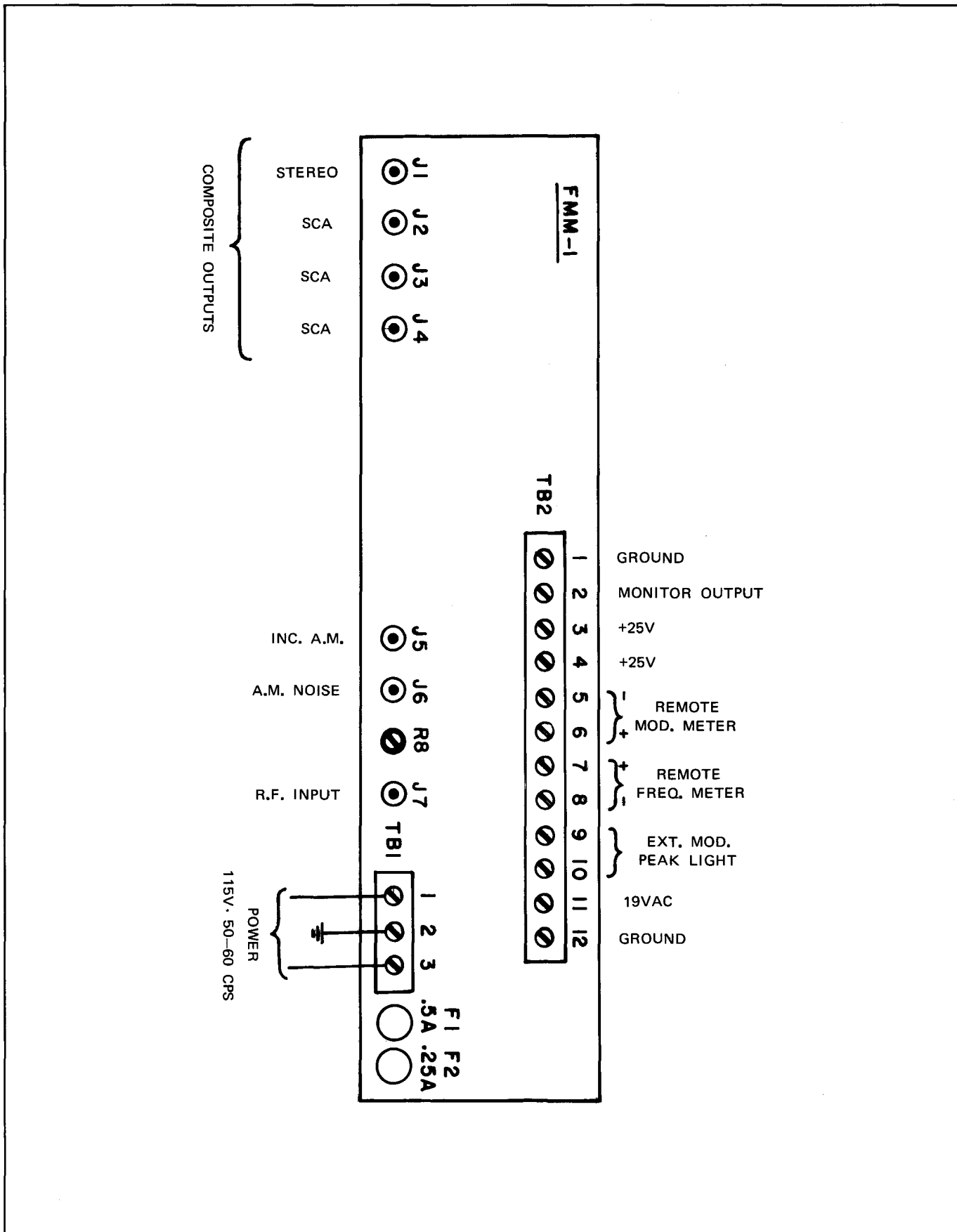

Figure 2-1

SECTION 2 INSTALLATION

2-1 INITIAL INSPECTION

Check the shipping carton for external damage. If the carton exhibits evidence of abuse in handling [holes, broken corners, etc.], ask the carrier's agent to be present when the unit is unpacked. Carefully unpack the unit to avoid damaging the equipment through use of careless procedures. Inspect all equipment for physical damage immediately after unpacking. Bent or broken parts, dents and scratches should be noted. If damage is found, refer to Paragraph 2-2 for the recommended claim procedure. Keep all packing material for proof of damage claim or for possible future use.

2-2 CLAIMS

If the unit has been damaged, notify the carrier immediately. File a claim with the carrier or transportation company and advise Belar of such action to arrange the repair or replacement of the unit without waiting for a claim to be settled with the carrier.

2-3 REPACKING FOR SHIPMENT

If the unit is to be returned to Belar, attach a tag to it showing owner and owner's address. A description of the service required should be included on the tag. The original shipping carton and packaging materials should be used for reshipment. If they are not available or reusable, the unit should be repackaged in the following manner:

- a. Use a double-walled carton with a minimum test strength of 275 pounds.
- b. Use heavy paper or sheets of cardboard to protect all surfaces.
- c. Use at least 4 inches of tightly packed, industry approved, shock absorbing material such as extra firm polyurethane foam or rubberized hair. **NEWSPAPER IS NOT SUFFICIENT FOR CUSHIONING MATERIAL.**
- d. Use heavy duty shipping tape to secure the outside of the carton.
- e. Use large **FRAGILE** labels on each surface.

f. Return the unit, freight prepaid, via air freight. Be sure to insure the unit for full value.

2-4 PREPARATION FOR USE

The FMM-1 Frequency and Modulation Monitor is designed to be mounted in a standard 19-inch rack mount. When mounted in a rack, a slight air space should be provided above and below the unit as the heat generated by the crystal oven should be dissipated. When the monitor is mounted above high heat generation equipment such as vacuum-tube power supplies, consideration should be given to cooling requirements which allow a free movement of cooler air through and around the FMM-1. In no instance should the ambient chassis temperature be allowed to rise above 50 degrees C [122 degrees F]. Mount the FMM-1 to the rack mount using four No. 10 screws and four No. 10 countersunk finishing washers.

The Model FMM-1 requires a 105 to 125 VAC single phase, 50 to 60 Hz power source. Consult Belar for operation with other power sources. Attach a three wire, grounded line cord to TB1 with the ground wire to terminal 2 and the AC line wires to terminals 1 and 3.

Connect a 50 ohm coaxial cable [RG-58] between the monitor probe on the transmitter [or RF amplifier] and the RF input connector J7, at the rear of the main chassis.

CAUTION: DO NOT APPLY MORE THAN 10 VOLTS RF TO THE MONITOR OR THE RF INPUT LEVEL CONTROL MAY BE DAMAGED.

If desired, connect external aural monitoring amplifier to terminals 1 and 2 on TB2. Note that this is an unbalanced 600 ohm output with terminal 1 grounded. A remote center frequency deviation meter and remote modulation meter may be connected to terminals 7, 8 and 5, 6 respectively, if desired. Observe the proper polarities [terminals 6 and 7 are positive] and note that the external loop resistance not including meters must be 5000 ohms. These meters must be obtained from Belar Electronics Laboratory, Inc. in order to comply with FCC regulations on remote metering. A remote peak modulation lamp may be connected to terminals 9 and 10. **CAUTION: DO NOT SHORT TERMINAL 9 TO GROUND.** The remote meters and lamp are contained in the MP-1 Remote Meter Panel.

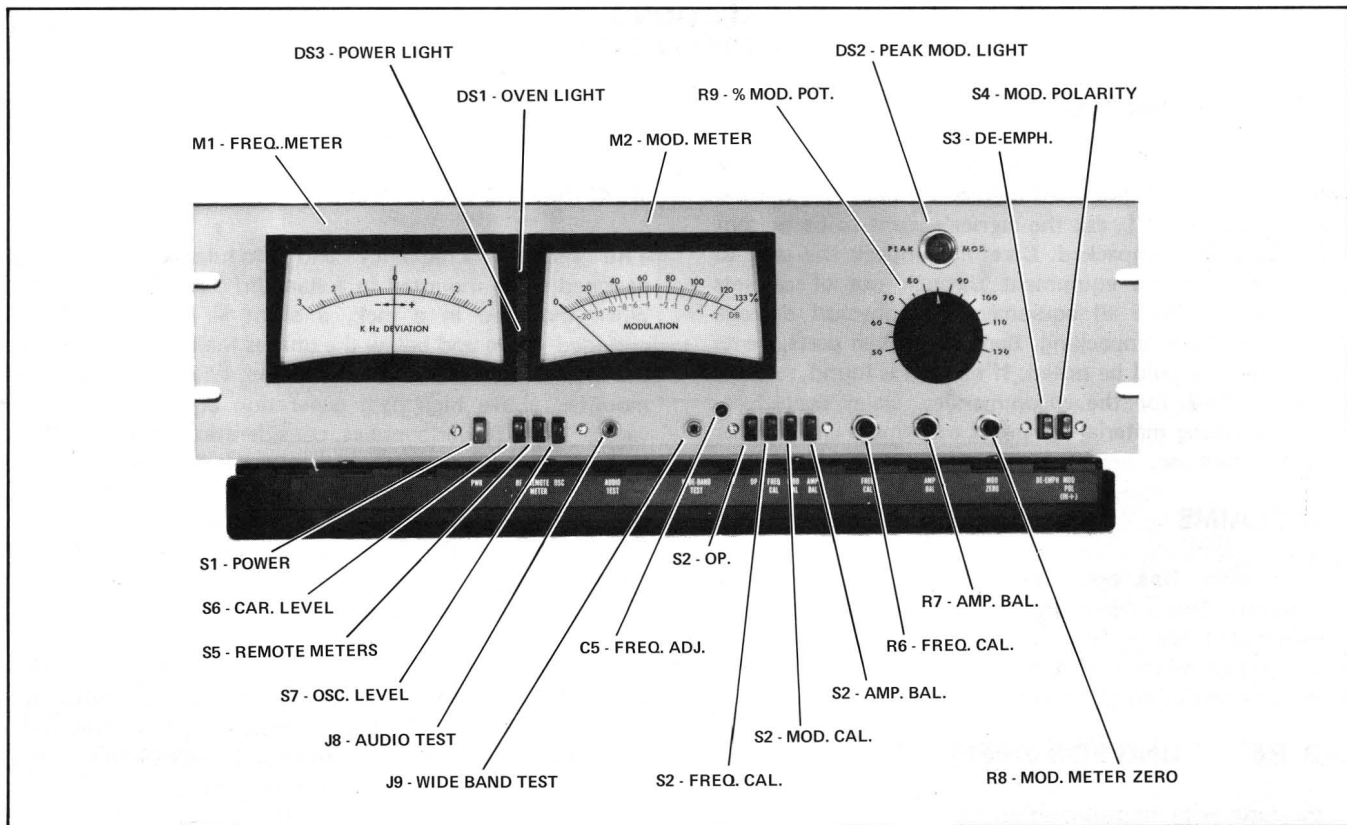

Figure 3-1

1. **POWER SWITCH**—When depressed turns the unit on. Power is applied to the crystal oven from the line and is independent of the power switch.

2. **POWER INDICATOR**—Lower amber light between the meters indicates that the unit is turned on.

3. **OVEN INDICATOR**—Upper red light between the meters indicates that heat is being applied in the crystal oven.

4. **RF SWITCH**—When depressed indicates the RF level on the percentage modulation meter.

5. **REMOTE SWITCH**—When in off [released] position removes both metering circuits from the remote metering terminals and substitutes the equivalent resistances.

6. **OSCILLATOR SWITCH**—When depressed indicates the oscillator level on the percentage modulation meter.

7. **FUNCTION SWITCH**—When in OP position disables all calibration circuits and places the unit in operation for measuring frequency deviation and total modulation.

8. **FUNCTION SWITCH**—When in AMP BAL position, the inputs to the frequency differential amplifier are shorted, allowing it to be calibrated.

9. **FUNCTION SWITCH**—When in FREQ CAL position, the 650 kHz calibrating oscillator is turned on and applied to the pulse counter frequency discriminator allowing it to be calibrated.

10. **FUNCTION SWITCH**—When in MOD CAL position applies a standard deviation to the monitor to check modulation calibration.

11. **FREQ ZERO POTENTIOMETER**—Standardizes the width of

the output pulse of the pulse counter discriminator to read zero in function 9 above.

12. **AMP BALANCE POTENTIOMETER**—Adjusts the DC balance of the frequency differential amplifier in function 8 above.

13. **MOD METER BALANCE**—Adjusts the percentage modulation meter to read zero with no modulation.

14. **DE-EMPHASIS SWITCH**—When released removes the 75 usec de-emphasis from the monitoring amplifier. This is also effective on the audio test output jack.

15. **POLARITY SWITCH**—Allows the percentage modulation meter to read either positive or negative modulation polarities. Depressed it reads positive, released it reads negative polarities.

16. **PERCENT-MODULATION POTENTIOMETER**—Pre-sets the peak modulation lamp to flash at the indicated modulation setting. This circuit is independent of modulation polarity and can be activated by either a positive or negative modulation peak or both.

17. **WIDEBAND TEST JACK**—Parallels the wideband outputs to the Add-On FMS-1 Stereo and SCM-1 SCA units. Permits tests to be made on the output of the counter-discriminator such as linearity and stereo composite waveform tests.

18. **AUDIO TEST JACK**—Test output from the monitoring amplifier. Permits linearity tests, frequency response tests, and FM noise tests to be made from the front panel, with de-emphasis in or out according to function 14.

19. **FREQ ADJUST**—Adjusts the frequency of the local oscillator. THIS MUST BE ADJUSTED WITH AN INSULATED ALIGNMENT SCREWDRIVER.

SECTION 3 OPERATION

3-1 INITIAL OPERATION

The following procedure should be followed for placing the unit into initial operation. Refer to Figure 3-1 for location of the control functions:

1. Before turning the unit on, depress the AMP BAL switch and release the REMOTE METER switch.
2. Depress the POWER switch and allow a 15 minute warm-up.
3. Depress the OSC switch; the reading on the percentage modulation meter should be approximately 100% or more.
4. Turn the RF level control on the back of unit maximum counterclockwise. Apply RF input to the RF input jack. Depress the RF switch and adjust the RF level control until the percentage modulation meter reads 100%. The monitor will operate with as little as 20%, but for AM noise calibration, the 100% level is used.
5. With the function switch in AMP BAL, adjust AMP BAL POTENTIOMETER to read center zero on the carrier deviation meter and adjust the MOD ZERO POTENTIOMETER to read zero on the modulation meter.
6. With the function switch in FREQ, adjust FREQ CAL POTENTIOMETER to read center zero on the carrier deviation meter.
7. Depress the MOD CAL switch; the modulation meter will read 100% to verify the accuracy of the calibration.
8. Depress OP switch and the monitor is now ready for operation.

3-2 NORMAL OPERATION

For normal operation, leave the FMM-1 in OP [operate] position. Changes in RF level will not affect the accuracy of the unit. It may be necessary to occasionally adjust the FREQ CAL POTENTIOMETER as in step 3-1-6 above.

The PEAK MOD POTENTIOMETER is usually set to 100% so that the PEAK LIGHT will flash at a modulation peak of

100% or greater. Since this indicator is independent of modulation polarity [i.e., it responds to both positive and negative peaks], it may flash when the modulation meter does not indicate the peak. The modulation meter polarity is switched by S4.

Note that when the MOD CAL switch is depressed, the calibrating signal is applied not only to the metering circuit but also to the peak light and monitoring amplifier. Hence the 60 Hertz square wave tone will be heard in an aural monitoring amplifier.

3-3 LOCAL OSCILLATOR FREQUENCY CALIBRATION

The FMM-1 is furnished adjusted to the customer's frequency. The monitor may be calibrated against an external frequency standard as follows: The transmitter is first set exactly to the assigned frequency using an outside frequency measuring service. Measure transmitter frequency as per steps 5, 6 and 8 under OPERATION, Paragraph 3-1. If the indicated center frequency deviation is not zero, the local oscillator frequency may be adjusted with the crystal tuning capacitor C5 [through the front panel] to bring the deviation to zero.

3-4 TRANSMITTER MEASUREMENTS

Normal transmitter proof-of-performance measurements may be made with the FMM-1. Frequency response, distortion, and noise measurements may be made through the front panel AUDIO TEST jack J8. Five volts RMS is available at 100% modulation so that most distortion and noise analyzers may be used. Measurements may be made with or without de-emphasis by activation of S3. The modulation meter has a flat frequency response characteristic so that with a pre-emphasized transmitter, the audio input level will have to be adjusted according to the standard 75 usec pre-emphasis curve.

AM noise measurements may be made at J6 on the back panel. With the RF level at 100%, the normal output of J6 for 100% AM is 0 db [0.78 volts] into a high impedance [500K or greater]. Hence a standard AC voltmeter such as contained in a distortion analyzer may be used.

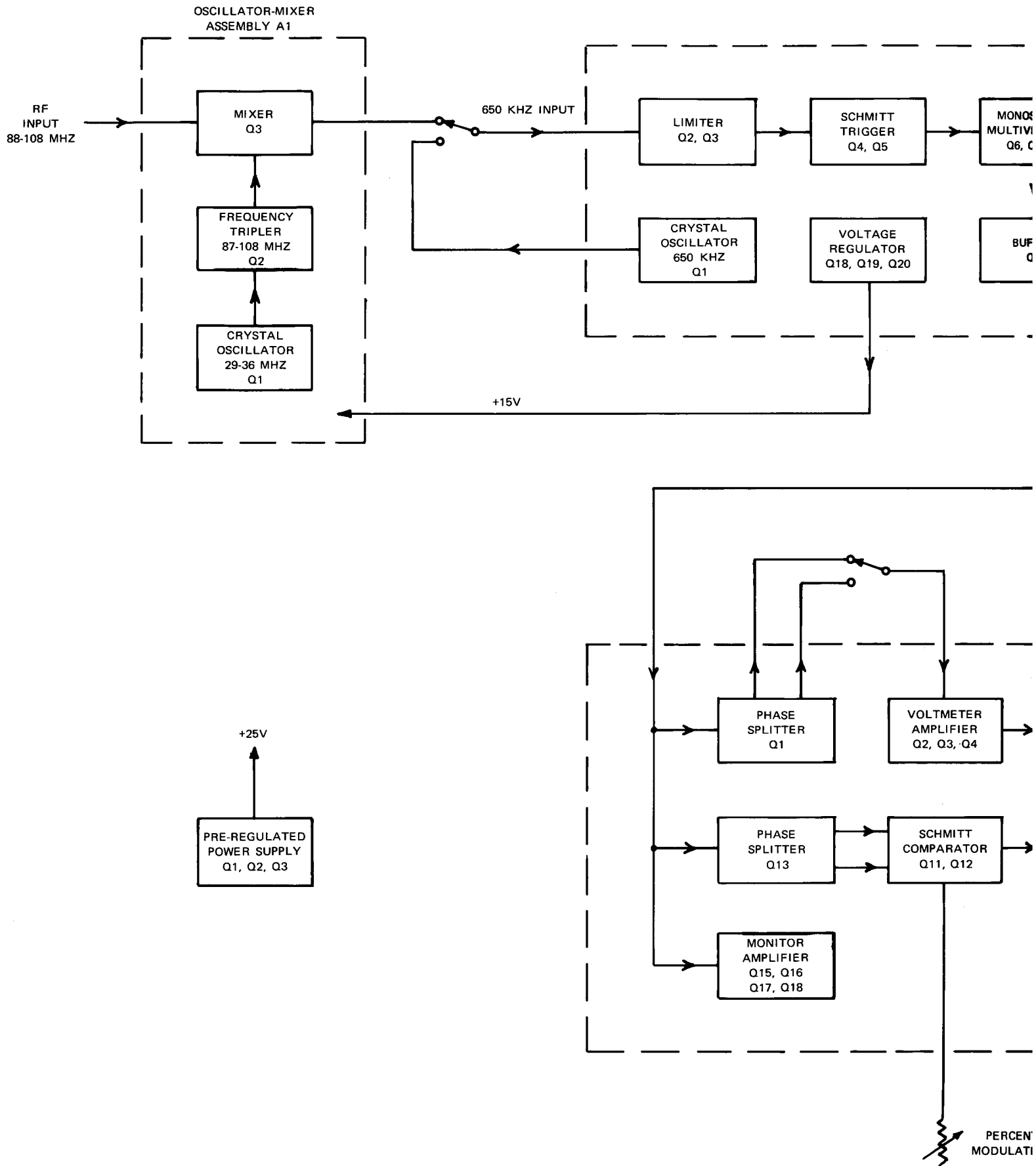
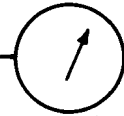
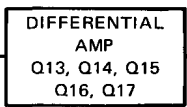
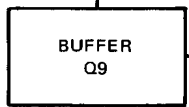
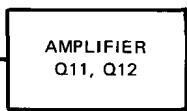
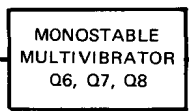
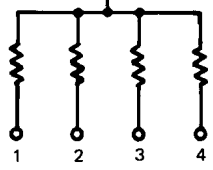

Figure 4-1

COUNTER ASSEMBLY A2



FREQ. DEV.



AMPLIFIER ASSEMBLY A3

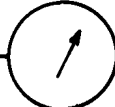
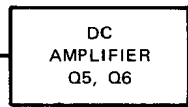
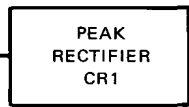
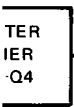

MODULATION METER

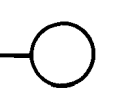
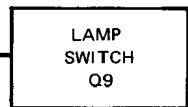
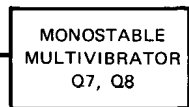

PEAK LIGHT

PERCENT MODULATION

SECTION 4 PRINCIPLES OF OPERATION

4-1 BLOCK DIAGRAM DESCRIPTION

Figure 4-1 is a simplified block diagram of the FMM-1 FM Frequency and Modulation Monitor. The signal paths are shown but the detailed switching circuitry has been omitted for clarity.

The incoming RF sample is applied to the mixer, A1Q3, along with the tripled local oscillator frequency to form an intermediate frequency [IF] of 650 kHz. This signal is a fully modulated FM signal [Figure 4-2-1] centered around 650 kHz and is applied to the pulse-counter discriminator assembly Card A2.

The limiter amplifies and removes any AM component from the IF signal. The signal is squared by the Schmitt trigger, whose output is differentiated to form a sharp trigger [Figures 4-2-2 and 6] to drive the monostable multivibrator, A2Q6, 7 and 8. The monostable multivibrator generates a pulse of fixed length and amplitude [Figure 4-2-3] each time it receives a trigger. Thus the output of the multivibrator is a series of pulses with a fixed length and amplitude whose spacing depends on the incoming frequency. Figure 4-2-7 illustrates this output with an FM modulated signal. Note how the spacing increases and decreases as the frequency is deviated about 650 kHz. This output is integrated by the low-pass filter whose average AC output is equivalent to the original FM modulation. The output of the monostable multivibrator is also applied to the buffer amplifier A2Q9 and integrated by an RC network to provide an average DC signal proportional to the carrier center frequency.

This DC signal is amplified by the differential amplifier and applied to the carrier deviation meter. The output of the integrating filter is amplified and applied to the modulation metering and peak flasher circuits on Card A3.

The modulation metering circuit consists of a phase splitter to allow either the positive or negative modulation polarity to be selected, a feedback amplifier, a peak diode detector circuit, and current amplifier to drive the modulation meter. The peak diode detector circuit has a very short charging time constant to allow the modulation meter to accurately respond to complex waveforms of multiplex signals as well as short duration bursts of program material.

The flasher circuit consists of an amplifier, phase splitter, Schmitt voltage comparator, and monostable multivibrator. The signal is split by the phase inverter and both phases are applied to the Schmitt comparator which has a dual input. The comparator will only respond to positive levels that exceed a given value determined by the setting of the percent modulation control. But since the phase inverter inverts the negative modulation, each input of the comparator receives a positive going signal—one

corresponding to the positive modulation and one corresponding to the negative modulation, thus making it independent of modulation polarity. Each time the level exceeds the pre-set level, the Schmitt comparator supplies a pulse to the monostable multivibrator. The width of the pulse formed by the multivibrator is set to 3 seconds duration as required by the FCC. The multivibrator turns on the transistor switch A3Q9 to allow the peak lamp to flash.

The monitoring amplifier is a feedback amplifier with push-pull output to provide a low distortion signal for aural monitoring and audio tests. De-emphasis is accomplished by controlling the frequency response of the internal gain and feedback loop.

The supply voltage is regulated to 25 volts by the pre-regulator [Q1, Q2, and CR6]. The supply to the pulse counter and oscillator mixer circuits is further regulated by the precision 15 volt regulator [A2Q18, A2Q19, A2Q20, and A2CR9].

4-2 DETAILED CIRCUIT DESCRIPTION

4-2-1 OSCILLATOR, TRIPLER AND MIXER CIRCUIT

The incoming RF is attenuated by R18 [RF level] and applied to pin 5 of the Oscillator, Tripler and Mixer Card. Diodes A1CR1 and A1CR2 prevent excessive RF levels from overloading the FET mixer A1Q3. Diode A1CR3 is used to measure the RF level and its DC output is applied to the modulation meter when S6 [CARRIER LEVEL] is depressed.

The crystal oscillator is a modified Clapp-Gouriet oscillator. This type of oscillator circuit is known for its frequency stability. The feedback ratio is determined by the ratio of A1C3 and A1C4. Since these capacitors are large in comparison to the transistor A1Q1 capacities, the transistor has little effect on the frequency. The crystal is connected to pins 7 and 8.

The series tuned circuit A1C1, A1L1 forces the crystal to operate in the third overtone mode. The crystal is stabilized at a temperature of 75 degrees C by the oven Y1. Variable Capacitor C5 [FREQUENCY ADJUST] adjusts the crystal frequency to that required by the channel frequency.

The output of the crystal oscillator is multiplied by 3 in the tripler stage A1Q2. Its final frequency is then 650 kHz above the incoming RF carrier frequency and is mixed in A1Q3 to produce a difference frequency of 650 kHz. The output of the mixer is filtered by the low-pass filter A1C12, A1RFC5, and the cable capacity interconnecting pin 2 to the input of Card A2.

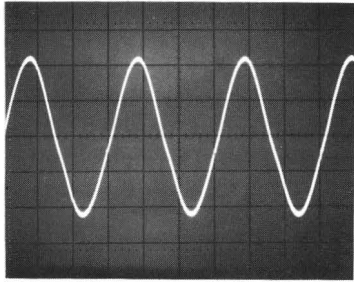

1

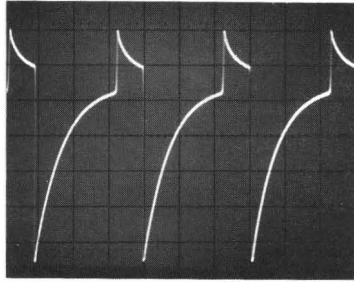

2

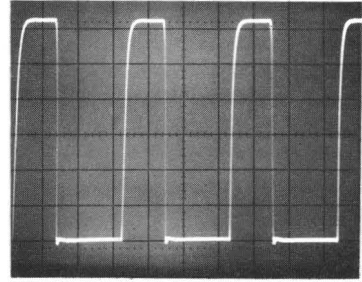

3

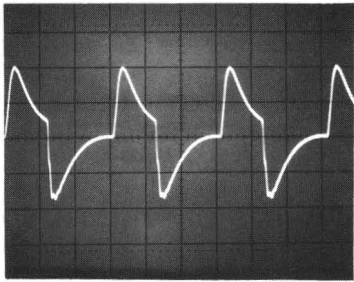

4

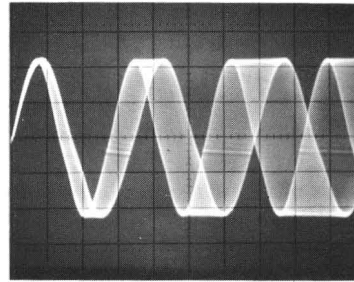

5

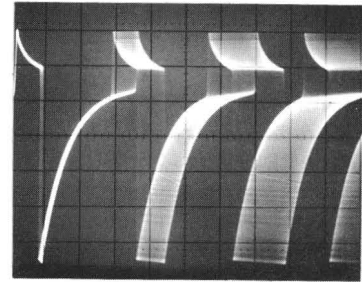

6

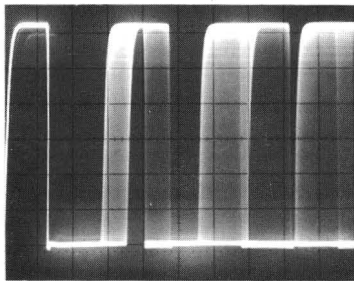

7

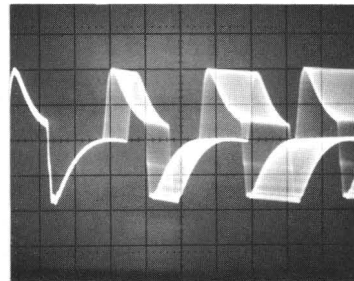

8

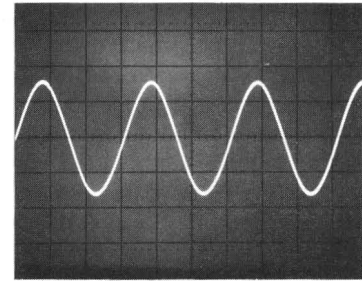

9

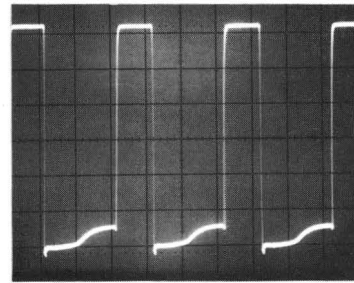

10

Figure 4-2

4-2-2 OSCILLATOR, COUNTER DISCRIMINATOR AND AMPLIFIER CIRCUITS

When the operate [OP] switch S2 is depressed, 15 VDC from pin 7 is applied to pin 4 to turn on diode A2CR1 so that the 650 kHz intermediate frequency, Figure 4-2-1, is applied to the limiter, A2Q2 and 3. This stage amplifies and removes any amplitude modulation component that may be present on the signal. The Schmitt trigger A2Q4 and 5 squares the signal by developing a pulse each time the signal crosses the zero axis in the positive direction. The output of the Schmitt trigger is differentiated, Figure 4-2-2, and applied to the monostable multivibrator, A2Q6, 7, and 8 through diode A2CR4.

The monostable multivibrator differs from the conventional multivibrator in that the timing capacitor A2C16 is charged through a constant current source, A2Q7, instead of a resistor. Zener Diode A2CR5 regulates the voltage to the base of transistor A2Q7, and silicon diode A2CR6 provides temperature compensation for the emitter-base junction of A2Q7. Potentiometer, R6 [FREQ CAL], in series with R5 [COARSE FREQUENCY CAL] connects the pins 9 and 10 to set the current through A2Q7. The current through A2Q7 sets the slope of the charging current of the timing capacitor A2C16 which determines the pulse width of the multivibrator. This modification of the multivibrator greatly increases both its stability and linearity when used as a pulse counter discriminator.

The output of the monostable multivibrator, Figure 4-2-3, is buffered by an emitter follower A2Q10 and is integrated by the low-pass filter FL1, Figure 4-2-4. This filter counts [averages] the number of pulses over a unit time interval by filtering out the 650 kHz pulses and only passing the modulation, Figure 4-2-9. The output of the low-pass filter is amplified by A2Q11 and buffered by the emitter follower A2Q12. The modulation output [baseband output] is taken off pin 12 to drive subsequent portions of the monitor.

The output of the monostable multivibrator is also buffered by transistor A2Q9. The emitter of A2Q8 is direct coupled to the base of A2Q9. Diodes A2CR7 and 8 form the emitter load so that the linearity of the multivibrator is preserved. This type of coupling decreases the rise time of the pulse output of A2Q9 and enables transistor A2Q9 to be driven between cut-off and saturation to form a precisely defined rectangular pulse of maximum stability for frequency measurements.

The output of transistor A2Q9 is integrated by the RC network A2R50 and A2C27 to provide a DC that is proportional to frequency. This DC is compared with the reference DC from the precision voltage divider, A2R40 and A2R41, by the differential amplifier A2Q13-17. Any difference in voltage then corresponds to a frequency deviation and is amplified by the differential amplifier and applied to the carrier deviation meter through pins 16 and 20. A2C26 couples the unfiltered modulation to the reference input of the differential amplifier to prevent low

modulating frequencies from affecting the frequency reading. The reference DC voltage is derived from the same 15 volt supply that powers the monostable multivibrator to form a bridge circuit so that the frequency measurement is relatively independent of supply voltage.

The 15 volt regulator is the series type to provide both voltage regulation and a low impedance to power the A2 Card. A2Q18 is the pass transistor and A2Q19 and 20 amplify the error difference between the output and reference zener diode, A2CR9. A2R52 sets the output to 15 volts.

The calibrating oscillator A2Q1 is a conventional Colpitts crystal oscillator. When the FREQ CAL switch S2 is depressed, 15 VDC from pin 7 is applied to pin 3 which supplies power to the calibrating oscillator and also turns on diode A2CR2 so that the 650 kHz calibrating signal is applied to the limiter, A2Q2 and A2Q3. Note that diode A2CR1 is now turned off in this mode of operation. The calibrating signal allows the pulse width of the monostable multivibrator to be standardized to correspond with the DC reference level of the differential amplifier.

Modulation calibration is accomplished by gating the 650 kHz calibrating signal on and off through the limiter. When the MOD CAL switch S2 is depressed, the calibrating oscillator is turned on as before. 19 volts, 60 Hertz is also applied to pin 2 to gate the limiter stage A2Q3 on and off at a 60 Hertz rate. The effective FM frequency deviation is from 0 to 650 kHz or 650 kHz peak to peak; the 650 kHz deviation is reduced to 150 kHz by the precision resistance divider A2R38 and A2R39. The square wave output from pin 13, through switch S2, is applied to the Amplifier Card Assembly A3 and the Composite Output Jacks J1-4. Capacitor A2C22 removes the overshoot from the leading edge of the square wave.

25 VDC is supplied to pin 1 through R4, on the main chassis, and to pin 11 to power the buffer A2Q10. R4 drops the 25 volts to pin 1 to approximately 21 volts to reduce the power dissipated in the series regulator A2Q18.

4-2-3 AMPLIFIER, METERING AND FLASHER CIRCUITS

The inputs to the monitoring amplifier, metering circuit, and peak flasher circuit are individually calibrated. The modulation metering circuit consists of a phase splitter to allow either the positive or negative modulation polarity to be selected, a feedback amplifier, a peak diode detector circuit, and current amplifier to drive the modulation meter. The baseband signal is applied to the phase splitter A3Q1 to allow either the positive or negative modulation to be selected by switch S4 [MOD POLARITY] on main chassis. Potentiometer A3R5 adjusts the gain on the negative polarity to exactly match the positive polarity. The wideband feedback amplifier consists of three transistors A3Q2, 3 and 4. Potentiometer A3R15 adjusts the gain of the amplifier to that value required for calibration. Diode rectifier A3CR1 rectifies the positive half of the signal to charge the capacitor A3C7 to a DC level

corresponding to peak value of the signal. The charging time constant is extremely short and is determined by the low output impedance of the feedback amplifier, diode resistance and A3C7. This short time constant allows the modulation meter to accurately respond to complex waveforms of multiplex signals as well as short duration bursts of program material. Resistor A3R20 controls the discharge time of A3C7.

Field-effect transistor A3Q5 provides a high impedance to the rectifier circuit and transistor A3Q6 provides the current gain to drive the modulation meter. Note that pins 12, 13 and 14 are connected to the MOD METER ZERO potentiometer, R8, on the main chassis to form a bridge circuit. R8 balances the bridge for zero current with no signal. With a signal, the voltage increases on the emitter of transistor A3Q6 to imbalance the bridge and current flows through resistors A3R24 and 25. A sample of the current through A3R24 is applied to the internal modulation meter M2 in series with A3R23; pins 10 and 11 connect to the modulation meter via switches S6 and S7. Resistor A3R23 controls both the damping and the rise time of the modulation meter. When a remote meter is used to read modulation, a sample of the current through A3R25 is applied to the remote meter. Pins 11 and 13 connect the remote modulation meter via the REMOTE METER switch S5. An external 6.2K ohm resistor must be used in series with the remote meter for correct damping and rise time. This resistance may include the line resistance.

The peak flasher circuit consists of an amplifier, phase splitter, Schmitt voltage comparator and monostable multivibrator. The baseband signal is applied to the low gain amplifier A3Q14 which is direct coupled to the phase splitter A3Q13. Potentiometer A3R49 sets the span for the PERCENT-MODULATION potentiometer R9 on the front panel. The Schmitt comparator has a dual input, A3Q11 and 12 to accept both negative and positive modulations respectively. The PERCENT-MODULATION potentiometer R9 is connected to pins 15, 16, and 17 to set the firing level of the comparator. Hence, each time the modulation exceeds the pre-set level, the Schmitt comparator fires and develops a pulse to trigger the monostable multivibrator. The monostable multivibrator

A3Q7 and 8 produces a rectangular pulse of three seconds duration which drives the lamp switch A3Q9. The PEAK MOD light DS2 is the collector load for transistor A3Q9. The power for the light is supplied by rectifier CR1 and capacitor C1. A remote PEAK MOD light is driven by the same power supply and switch and may be connected to terminals TB2-9 and 10.

The monitoring amplifier is a three stage feedback amplifier to provide a low distortion signal for both aural monitoring and audio tests. The baseband signal is applied to the input stage A3Q18 which both amplifies the signal and sums the feedback voltage in the emitter. Transistor A3Q17 provides additional amplification to drive the output transistors A3Q15 and 16. Since the output transistors are a complementary pair, they operate in push-pull. Diodes A3CR4 and 5 provide forward bias to allow the output transistors to operate class AB.

Feedback is taken from the output and applied to the emitter of the input stage through A3R57. When terminals 24 and 26 are connected to each other and terminals 23 and 27 are connected to each other, the feedback follows a 75 usecond pre-emphasis curve so that the resultant output is de-emphasized according to a 75 usecond curve. A3C22 controls the gain and phase of the amplifier so that it is unconditionally stable. The DE-EMPHASIS switch S3 makes the necessary connections. A3R51 provides the 600 ohm output impedance to drive an aural monitoring amplifier and A3R52 provides the 10K ohm output impedance for audio tests.

The main power supply consists of a full wave bridge rectifier followed by a voltage regulator. Transistor Q1 is the pass transistor and is driven by the current amplifier Q2 which has its base referenced to zener diode CR6. Diode CR7 provides short circuit protection along with R3. When excessive current is drawn from the regulator, the voltage drop across R3 along with the emitter-base voltages of Q1 and Q2 exceeds the voltage drop across CR7 and the current is limited to a safe value to prevent damage to the transistors. Diode CR1 and capacitor C1 provide power to operate the PEAK MOD light.

SECTION 5 MAINTENANCE

5-1 INTRODUCTION

This section contains maintenance and service information for the FMM-1 Frequency and Modulation Monitor. Included are Performance Checks, Adjustments and Calibration Procedures and Troubleshooting Techniques.

5-2 PERFORMANCE CHECKS

The FMM-1 is self-checking to a degree. Before performing the check procedure, release all push buttons [out position] depressing or leaving depressed the AMP BAL switch S2 and the MOD POL switch S4. No connections should be made to the back terminals or connectors except for the line cord to TB1.

5-2-1 POWER AND OVEN CHECK

With AC power connected to the FMM-1 and the power switch off [released], the oven light DS1 should cycle on and off approximately every 30 seconds after initial warm-up. When on, heat is applied to the oven. Depressing the POWER switch S1 turns the unit on, and power light DS3 indicates that the power is on.

5-2-2 OSCILLATOR LEVEL CHECK

Depressing the OSC level switch S7 indicates the oscillator level on the MODULATION meter M2. The reading of the level should be greater than 100% and should be noted for future reference.

5-2-3 FREQUENCY METER AMPLIFIER CHECK

Depress the AMP BAL switch S2 and adjust AMP BAL potentiometer R7 maximum clockwise to maximum counterclockwise; the FREQUENCY meter M1 pointer should go off scale in the positive and negative direction respectively. Return the pointer to zero for normal operation.

5-2-4 FREQ METER DISCRIMINATOR CHECK

Depress the FREQ CAL switch S2 and adjust the FREQ CAL potentiometer R6 maximum clockwise to maximum counterclockwise; the FREQUENCY meter M1 pointer should go off scale in the positive and negative direction respectively. Return the pointer to zero for normal operation.

5-2-5 MOD METER AMPLIFIER ZERO CHECK

Depress the AMP BAL switch S2 and adjust the MOD ZERO potentiometer R8 maximum clockwise to maximum counterclockwise; the MODULATION meter M2 pointer should move in a positive and negative direction about zero. Return the pointer to zero for normal operation.

5-2-6 MODULATION CALIBRATOR CHECK

Depress the MOD CAL switch S2. The MODULATION meter M2 should read 100%. The FREQUENCY meter M1 may move off from zero to plus or minus a few hundred cycles.

5-2-7 REMOTE METER SWITCH CHECK

Depress the MOD CAL switch S2. The MODULATION meter M2 should read 100%. Adjust the FREQ CAL potentiometer R6 to a reading of plus 1 kHz. Depress the REMOTE METER switch S5. This MODULATION meter M2 reading should decrease approximately 6% and the FREQUENCY meter M1 should return to zero. Release the REMOTE METER switch S5 and the meters should return to the previous readings. Return the FREQ CAL potentiometer R6 to normal as in step 5-2-4.

5-2-8 PERCENT MOD POTENTIOMETER CHECK

Depress the MOD CAL switch S2. Adjust the PERCENT MODULATION potentiometer R9 to just turn on the PEAK MODULATION light DS2. The light should turn on at 100%. The light will continue to flash on and off at a rate of 3 seconds on to a fraction of a second off.

5-2-9 MODULATION POLARITY CHECK

Depress the MOD CAL switch S2. The MODULATION meter M2 should read 100%. Release the MOD POL switch S4 and the MODULATION meter should continue to read 100%.

5-2-10 CARRIER LEVEL CHECK

Turn RF level control R18 maximum counterclockwise. Apply RF carrier to the RF INPUT connector J7 [40 milliwatts is more than sufficient to drive the monitor to 100% carrier level indication]. Depress RF switch S6 and adjust RF level control R18 until the MODULATION meter M2 reads 100%. If considerable range remains on R18, the RF output from the transmitter should be reduced by adjusting the coupling probe in the transmitter.

5-2-11 OPERATE CHECK

With the RF carrier applied as in step 11, depress the OPERATE switch S2. The FREQUENCY meter M1 will indicate the frequency deviation from the assigned channel frequency. The MODULATION meter M2 will indicate the presence of modulation. The PEAK MODULATION light DS2 will indicate positive and negative modulation peaks according to the setting of the PERCENT MODULATION potentiometer. It may be noted that the MODULATION meter M2 may not track at all times with the PEAK MODULATION light while monitoring program material.

This is due to the asymmetrical nature of certain types of program material, i. e., the positive and negative peaks are not equal in amplitude. Since the PEAK MODULATION light circuitry automatically selects the higher of the two polarities, it can register a peak opposite to the polarity to which the MODULATION meter is set.

5-2-12 DE-EMPHASIS SWITCH CHECK

With a 15 kHz modulated signal applied to the monitor, the monitor amplifier output may be monitored at the AUDIO TEST jack J8. Depressing the DE-EMPHASIS switch S3 will cause a 17 db decrease in output level, and releasing S3 will return the amplifier to a flat response. Note that the 600 ohm monitoring amplifier output on TB2 is also de-emphasized by this switch.

5-3 ADJUSTMENTS, CALIBRATION AND TROUBLESHOOTING

The following guide for adjustments, calibration and troubleshooting follows the same numbering sequence as the PERFORMANCE CHECKS for ease of service.

5-3-1 POWER AND OVEN

- a. If the oven light DS1 fails to light, check fuse F2 [0.25A].
- b. If the oven light DS1 lights but fails to cycle on and off, remove oven from unit. If the oven is cold, check continuity of the heater winding between pins 3 and 4 of the oven. If the oven is hot, the thermostat circuit is stuck closed and the oven should be replaced with a new unit. Note that both malfunctions will result in an indicated carrier frequency error. The monitor oven should not be operated with a stuck thermostat as the crystal may be damaged from overheating. The monitor may be operated temporarily with the oven fuse removed.
- c. If the oven light DS1 fails to light but the oven heats, check the oven light.
- d. If the power light DS3 fails to light, check fuse F1 [0.5A].
- e. If the power light DS3 lights but the monitor is inoperative, check the voltage on terminal 3 of TB2 to ground. Normal voltage is 26 VDC. If the voltage is high [37 VDC], Q2 or CR6 is defective. If the voltage is 0, Q1 is open or a malfunction exists in the pre-regulator.
- f. If the power light DS3 fails to light and the monitor functions normally, check the power light.

5-3-2 OSCILLATOR LEVEL

- a. If the oscillator level reads 0, transistor A1Q1 is malfunctioning.
- b. If the oscillator level reads above 80% but not the normal peak, adjust A1L1 for an indicated peak on M2.

- c. If the oscillator level will not peak with the adjustment of A1L1, the crystal Y1 [in oven] may be defective.

5-3-3 FREQUENCY METER AMPLIFIER

- a. If the FREQUENCY meter M1 pointer fails to go off scale in both the positive and negative direction, transistors A2Q14 and 15 are saturated and A2R47 should be replaced with the next higher value [9.1K or 10K ohms].
- b. If the FREQUENCY meter M1 pointer fails to move and the rest of the monitor functions normally, release REMOTE METER switch S5. Note that if remote meters are used and the malfunction is cleared when the switch S5 is released, a malfunction exists on the remote meter lines.
- c. If releasing the REMOTE METER switch S5 does not clear the malfunction, A2Q13 and 17 are malfunctioning.

5-3-4 FREQ METER DISCRIMINATOR

- a. If the FREQUENCY meter M1 pointer fails to go off scale in both the positive and negative directions, return the FREQ CAL potentiometer R6 to its midpoint and adjust the coarse frequency potentiometer R5 to zero M1.
- b. If the FREQUENCY meter M1 is off scale and cannot be brought on scale with R6, as in step (a) above, but the modulation calibrator functions normally as in step 5-2-6, check the waveform on the collector of transistor A2Q9. A low capacity probe should be used with the oscilloscope to preserve the waveshape and the waveshape should be as shown in Figure 4-2-3. If the waveshape does not have a straight base-line as in Figure 4-2-10, transistor A2Q9 is not driven into full saturation and should be replaced. Note that this malfunction can also cause excessive frequency drift in the discriminator.
- c. If the FREQUENCY meter M1 is off scale and the modulation calibrator does not check as in step 5-2-6, but the unit functions normally in the OPERATE position, the calibrating oscillator is not functioning or the diode switch A2CR2 is open. Check also that 15 VDC is applied to the diode anode.
- d. If the unit does not function in the OPERATE position in step (c) above, the counter-discriminator circuits are malfunctioning, and the signal may be traced with the aid of the waveforms in Figure 4-2. A low capacity probe should be used with the oscilloscope to preserve the waveshape.

5-3-5 MOD METER AMPLIFIER ZERO

- a. If the MODULATION meter M2 will not zero, and the modulation calibrator functions but does not indicate accurately, the bias on transistor A3Q3 is off. Increasing the value of A3R16 will decrease the meter reading by shifting the zero to the negative direction, and decreasing A3R16 will increase the meter reading by shifting the zero to the positive direction. A3R16 should range between 24K and 30K ohms and if it does not, replace A3Q5 or A3Q3.

b. If the MODULATION meter M2 reads off scale, check resistors A3R24 and 25 for an open circuit.

5-3-6 MODULATION CALIBRATOR

a. If the MODULATION meter M2 reads in error but is within 20% for positive polarity [MOD POL switch S4 depressed] and the PERCENT MOD checks as in step 5-2-8, adjust potentiometer A3R15 for the correct reading of 100% after zeroing the meter as in step 5-2-5.

b. If both the MODULATION meter M2 and the PERCENT MOD potentiometer R9 read in error, check the voltage output of the 15 volt regulator on card A2 and adjust A2R52 for 15 volts output if necessary. Usually the FREQ METER DISCRIMINATOR CHECK will be off in step 5-2-4 with the 15 volt regulator out of adjustment.

5-3-7 REMOTE METER SWITCH

a. With remote meters connected to the monitor, the readings of the FREQUENCY meter M1 and the MODULATION meter M2 should remain unchanged with the REMOTE METER switch S5 depressed or released. If the readings do change, check for faults on the remote meter lines. When the remote meters are not connected to the monitor, the readings will change as in step 5-2-7.

5-3-8 PERCENT MOD POTENTIOMETER

a. If the PERCENT MOD potentiometer R9 reads in error, the knob may be slipped to the correct reading by loosening the two set screws and retightening after adjusting.

b. The span of the PERCENT MOD potentiometer may be checked by applying a 400 cycle modulated signal to the monitor and checking the tracking at the 50% and 100% modulation points. Adjust A3R49 so that the percentage difference on the PERCENT MOD potentiometer is 50% when the modulation level is changed from 100% to 50%. Slip the knob as in step (a) above if it is necessary to correct the reading at 100% after the span has been adjusted.

5-3-9 MODULATION POLARITY

a. With a 400 cycle, 100% modulated signal, adjust A3R5 to obtain equal reading on MODULATION meter M2 when

the MOD POL switch S4 is cycled from positive to negative. Note that the adjustment can be observed in the negative polarity position.

b. If the negative polarity is off seriously and the monitor is noisy, check the pre-regulated power supply as in step 5-3-1-e.

5-3-10 CARRIER LEVEL

a. If no RF level is observed and the monitor is functioning normally in the OPERATE position, check diode A1CR3.

5-3-11 OPERATE

a. If the monitor fails to function in the OPERATE position and all other functions are correct, check diode switch A2CR1. Check also that 15 VDC is applied to the diode anode.

b. If the FREQUENCY deviation is off scale and the MODULATION meter is normal in the OPERATE position, check local oscillator peaking as in step 5-3-2.

c. If the FREQUENCY deviation is off scale and the MODULATION meter is normal in the OPERATE position, check the oven cycling as in step 5-3-1-b. If the oven is cycling and the transmitter frequency is correct, crystal Y1 [in oven] is defective.

d. If the monitor fails to function in the OPERATE position and the diode switch circuit is functioning, check transistors A1Q2 and A1Q3.

5-3-12 DE-EMPHASIS SWITCH

a. If DE-EMPHASIS switch S3 does not function normally, check capacitors A3C20 and 22. In the DE-EMPHASIS position, capacitor A3C20 is connected to the circuit by S3 switch contacts connecting pins 24 and 26, and capacitor A3C22 is connected to the circuit by S3 switch contacts connecting pins 23 and 27.

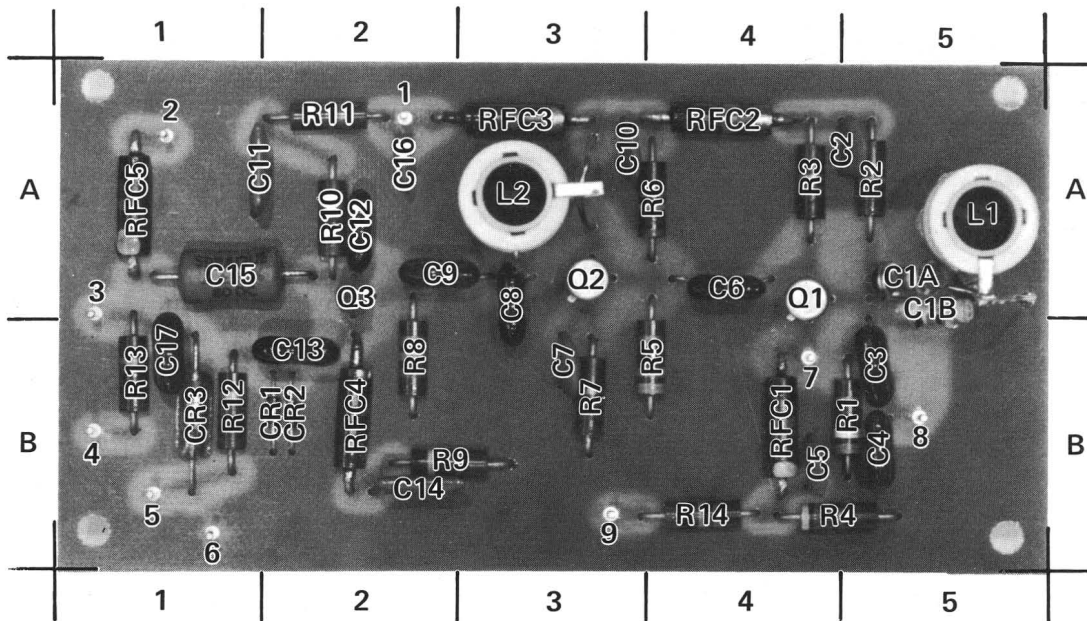

Figure 5-1

REF DESIG	GRID LOC	REF DESIG	GRID LOC	REF DESIG	GRID LOC	REF DESIG	GRID LOC	REF DESIG	GRID LOC	REF DESIG	GRID LOC
R1	B5	R10	A2	C4	B5	C13	B2	RFC5	A1	PINS	
R2	A5	R11	A2	C5	B4	C14	B2	CR1	B2	1	A2
R3	A4	R12	B1	C6	A4	C15	A1	CR2	B2	2	A1
R4	B4	R13	B1	C7	B3	C16	A2	CR3	B1	3	A1
R5	B4	R14	B4	C8	A3	C17	B1	Q1	A4	4	B1
R6	A4	C1A	A5	C9	A2	RFC1	B4	Q2	A3	5	B1
R7	B3	C1B	A5	C10	A3	RFC2	A4	Q3	A2	6	B1
R8	B2	C2	A5	C11	A1	RFC3	A3	L1	A5	7	B4
R9	B2	C3	B5	C12	A2	RFC4	B2	L2	A3	8	B5

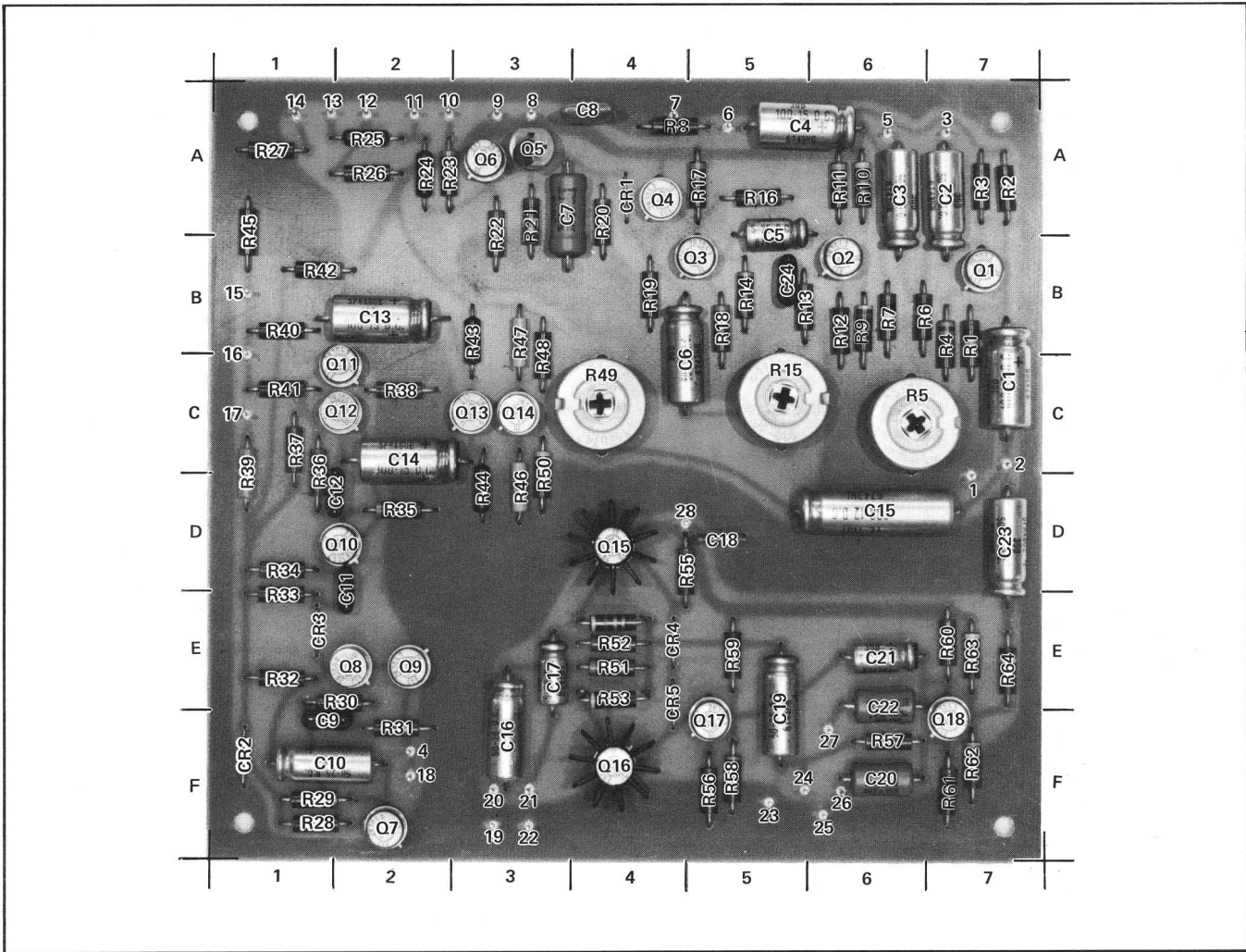

Figure 5-3

REF DESIG	GRID LOC	REF DESIG	GRID LOC	REF DESIG	GRID LOC	REF DESIG	GRID LOC	REF DESIG	GRID LOC	REF DESIG	GRID LOC	REF DESIG	GRID LOC
R1	B7	R21	A3	R41	C1	R61	F7	C17	E3	Q13	C3	9	A3
R2	A7	R22	B3	R42	B1	R62	F7	C18	D5	Q14	C3	10	A2
R3	A7	R23	A2	R43	B3	R63	E7	C19	E5	Q15	D4	11	A2
R4	B7	R24	A2	R44	D3	R64	E7	C20	F6	Q16	F4	12	A2
R5	C6	R25	A2	R45	B1	C1	C7	C21	E6	Q17	E5	13	A1
R6	B6	R26	A2	R46	D3	C2	A7	C22	E6	Q18	F7	14	A1
R7	B6	R27	A1	R47	B3	C3	A6	C23	D7	CR1	A4	15	B1
R8	A4	R28	F1	R48	C3	C4	A5	C24	B5	CR2	F1	16	C1
R9	B6	R29	F1	R49	C4	C5	B5	Q1	B7	CR3	E1	17	C1
R10	A6	R30	E2	R50	D3	C6	C4	Q2	B6	CR4	E4	18	F2
R11	A6	R31	F2	R51	E4	C7	A3	Q3	B5	CR5	E4	19	F3
R12	B6	R32	E1	R52	E4	C8	A4	Q4	A4	PINS		20	E3
R13	B5	R33	E1	R53	E4	C9	F1	Q5	A3	1	D7	21	F3
R14	B5	R34	D1	R54	E4	C10	F1	Q6	A3	2	C7	22	F3
R15	C5	R35	D2	R55	D4	C11	E2	Q7	F2	3	A7	23	F5
R16	A5	R36	D1	R56	F5	C12	D2	Q8	E2	4	F2	24	F5
R17	A5	R37	C1	R57	F6	C13	B2	Q9	E2	5	A6	25	F6
R18	B5	R38	C2	R58	F5	C14	C2	Q10	D2	6	A5	26	F6
R19	B4	R39	D1	R59	E5	C15	D6	Q11	C2	7	A4	27	F6
R20	A4	R40	B1	R60	E7	C16	F3	Q12	C2	8	A3	28	D4

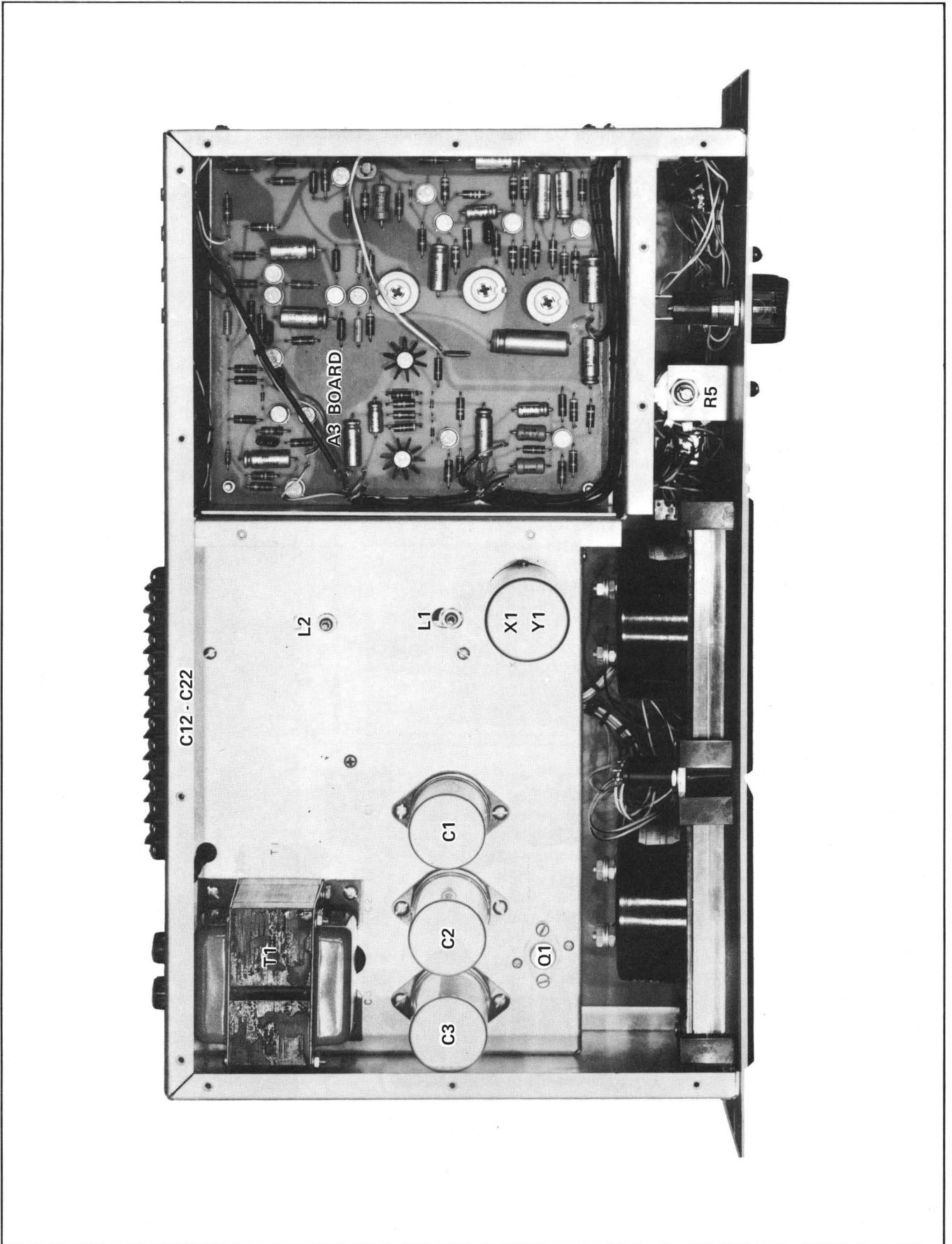

Figure 5-4

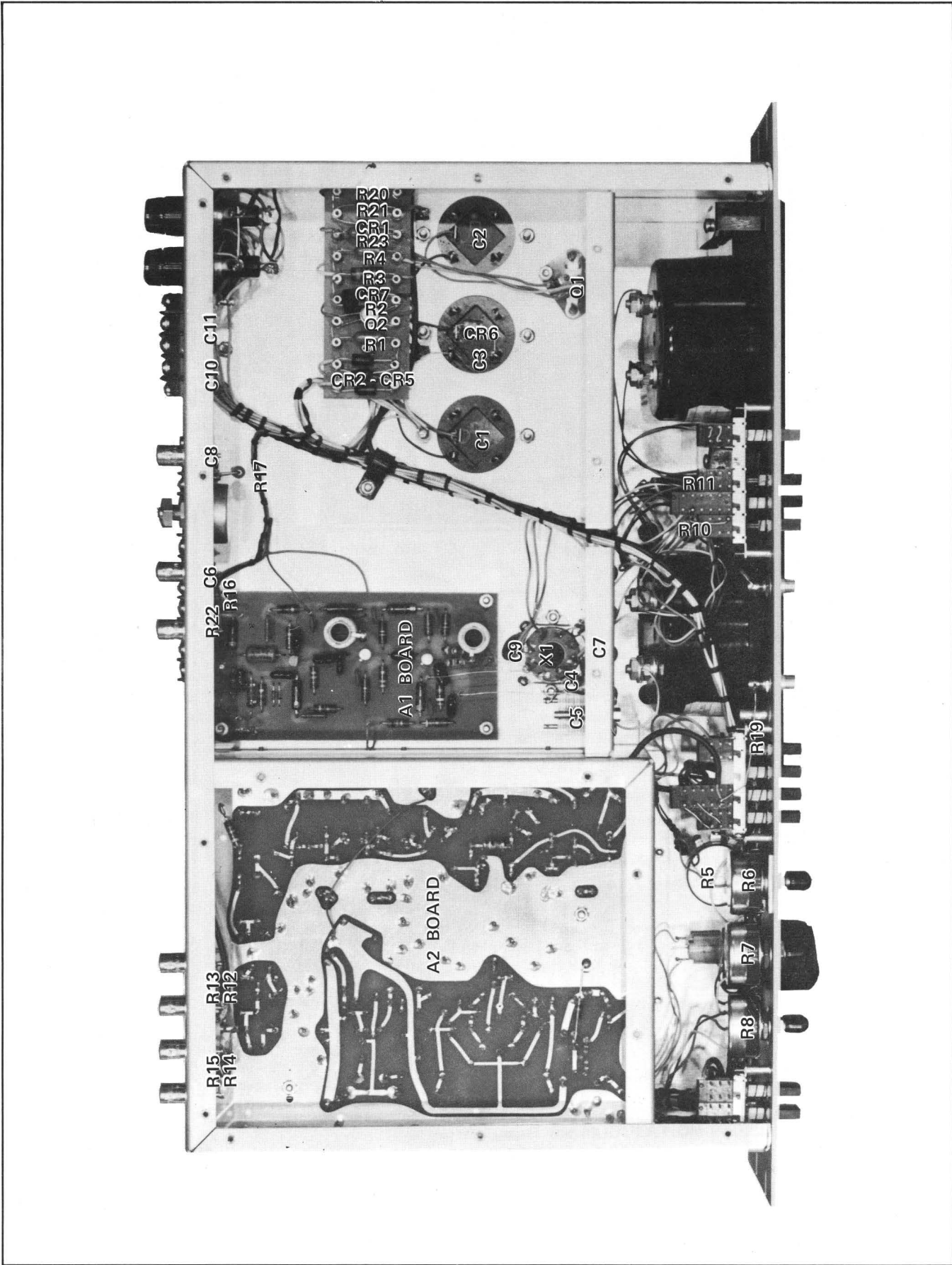

Figure 5-5

SECTION 6 REPLACEABLE PARTS

6-1 INTRODUCTION

This section contains information for ordering replaceable parts for the monitor. The table lists the parts in alpha-numerical order of their reference designations and provides a description of the part with the manufacturers' number and the Belar part number. Those parts with only a Belar part number should be obtained directly from Belar.

6-2 ORDERING INFORMATION

To order a replacement part from Belar, address the order or inquiry to Belar and supply the following

information:

- a. Model number and serial number of unit.
- b. Description of part including the reference designation and location.
- c. Belar part number.

To order a part from a manufacturer other than Belar, provide the complete part description and the manufacturer's part number from the table.

REFERENCE DESIGNATORS

A	= assembly	J	= jack	S	= switch
C	= capacitor	L	= inductor	T	= transistor
CR	= diode	M	= meter	TB	= terminal board
DS	= device signaling(lamp)	P	= plug	W	= cable
F	= fuse	Q	= transistor	X	= oven
FL	= filter	R	= resistor	Y	= crystal

ABBREVIATIONS

CER	= ceramic	MEG	= meg	POT	= potentiometer
COMP	= composition	METFLM	= metal film	SEMICON	= semiconductor
CONN	= connector	MY	= mylar	SI	= silicon
ELECT	= electrolytic	PC	= printed circuits	U	= micro
F	= farads	PIV	= peak inverse voltage	VDCW	= dc working volts
FXD	= fixed	POLY	= polystyrene	W	= watts
GE	= germanium	PORC	= porcelain	WW	= wirewound
K	= kilo = 1000				

PARTS LIST

MAIN CHASSIS REFERENCE DESIGNATION	DESCRIPTION	PART NUMBER
C1	C: FXD ELECT 500 UF 50 VDC SPRAGUE TVL1330	0180-0001
C2	C: FXD ELECT 1000 UF 50 VDC SPRAGUE TVL1338	0180-0002
C3	C: FXD ELECT 1000 UF 50 VDC SPRAGUE TVL1338	0180-0002
C4	C: FXD CER 15 PF 2% CENTRALAB TCZ	0150-0001
C5	C: VAR AIR 3.2-50 PF JOHNSON 148-4	0121-0001
C6	C: FXD FLM .0047 UF 10% 80 VDC SPRAGUE 192P	0120-0001
C7	C: FXD CER .01 UF 1 KV AUTOMATIC COMP	0150-0003
C8	C: FXD MICA 250 PF 5% 500 VDC ELMENCO DM15	0140-0001
C9 thru C11	C: FXD CER .01 UF 1 KV AUTOMATIC COMP	0150-0003
C12 thru C22	C: FXD CER .001 UF 1 KV SPRAGUE X5E	0150-0004
CR1 thru CR5	DIODE: SILICON 1N2070	1900-0003
CR6	DIODE: ZENER 1N3030B	1900-0004
CR7	DIODE: BELAR	1900-0010
DS1	LAMP: INDICATOR ASSEMBLY RED DIALCO	1450-0002
DS2	LAMP: INCANDESCENT 28V 0.07A GE1829	2140-0001
DS3	LAMP: INDICATOR ASSEMBLY AMBER DIALCO	1450-0003
F1	FUSE: CARTRIDGE 1/4A 250V LITTLEFUSE 3AG - 1/4A	2110-0001
F2	FUSE: CARTRIDGE 1/4A 250V LITTLEFUSE 3AG - 1/4A	2110-0002
M1	FREQUENCY METER: ± 3 kHz	1120-0001
M2	MODULATION METER: 0 TO 133% MOD	1120-0002
Q1	TRANSISTOR: SILICON 2N3054	1850-0009
Q2	TRANSISTOR: SILICON 2N3053	1850-0008
R1	R: FXD WW 1.5 OHM 5% 3W SPRAGUE 242E	0811-0001
R2	R: FXD COMP 1K OHM 5% 1/2W RC20GF	0686-1025
R3	R: FXD WW 0.33 OHM 5% 1W IRC-BWH	0811-0002
R4	R: FXD WW 33 OHM 5% 3W SPRAGUE 242E	0811-0003
R5	R: VAR WW 500 OHM 10% 2W RA20NASD 501A	2100-0001
R6	R: VAR WW 50 OHM 10% 2W RA20NASD 500A	2100-0002
R7	R: VAR WW 100 OHM 10% 2W RA20NASD 101A	2100-0003
R8	R: VAR WW 100 OHM 10% 2W RA20NASD 101A	2100-0003
R9	R: VAR WW 500 OHM 10% 2W RA20NASD 501A	2100-0001
R10	R: FXD COMP 6.2K OHM 5% 1/2W RC20GF	0686-6225
R11	R: FXD COMP 5.1K OHM 5% 1/2W RC20GF	0686-5125
R12 thru R14	R: FXD COMP 2.2K OHM 5% 1/2W RC20GF	0686-2225
R15	R: FXD COMP 560 OHM 5% 1/2W RC20GF	0686-5615
R16	R: FXD COMP 15K OHM 5% 1/2W RC20GF	0686-1535
R17	R: FXD COMP 100 OHM 10% 1W RC32GF	0690-1011
R18	R: VAR COMP 100 OHM 10% 2W RV4LAYSAS101A	2100-0010
R19	R: FXD COMP 1K OHM 5% 1/2W RC20GF	0686-1025
R20,R21	R: FXD COMP 200 OHM 5% 1/2W RC20GF	0686-2015
R22	R: FXD COMP 47K OHM 5% 1/2W RC20GF	0686-4735
R23	R: FXD WW 100 OHM 5% 3W SPRAGUE 242E	0811-0004
S1,S5,S6,S7	S: PUSH BUTTON POWER-METER	3101-0001
S2	S: PUSH BUTTON FUNCTION	3101-0002
S3,S4	S: PUSH BUTTON DE-EMPHASIS-POLARITY	3101-0003
T1	TRANSFORMER: POWER	9100-0001
TB1	TERMINAL BLOCK: 3 PT	0360-0001
TB2	TERMINAL BLOCK: 12 PT	0360-0002
X1	OVEN: CRYSTAL 117V 75 DEGREES CENTIGRADE	0410-0001
Y1	CRYSTAL: FREQUENCY 29-36 MHz	0410-0002
A1 CARD, OSCILLATOR, TRIPLER AND MIXER		
A1C1A A1C1B	C: FXD CER 22 PF 2% NPO CENTRALAB TCZ C: FXD CER 5PF 2% N750 CENTRALAB TCN	0150-0005 0150-0006

REFERENCE DESIGNATION	DESCRIPTION	PART NUMBER
A1C2	C: FXD CER 0.01 UF 100 VDC SPRAGUE TGS10	0150-0007
A1C3	C: FXD MICA 250 PF 5% 500 VDC ELMENCO DM15	0140-0001
A1C4	C: FXD MICA 120 PF 5% 500 VDC ELMENCO DM15	0140-0002
A1C5	C: FXD CER 0.01 UF 100 VDC SPRAGUE TGS10	0150-0007
A1C6	C: FXD MICA 51 PF 5% 500 VDC ELMENCO DM15	0140-0003
A1C7	C: FXD CER 0.01 UF 100 VDC SPRAGUE TGS10	0150-0007
A1C8	C: FXD MICA 20 PF 5% 500 VDC ELMENCO DM15	0140-0004
A1C9	C: FXD MICA 27 PF 5% 500 VDC ELMENCO DM15	0140-0005
A1C10	C: FXD CER 0.01 UF 100 VDC SPRAGUE TGS10	0150-0007
A1C11	C: FXD CER 0.1 UF 50 VDC SPRAGUE 5C50	0150-0008
A1C12	C: FXD MICA 20 PF 5% 500 VDC ELMENCO DM15	0140-0004
A1C13	C: FXD MICA 500 PF 5% 500 VDC ELMENCO DM15	0140-0006
A1C14	C: FXD CER 0.1 UF 50 VDC SPRAGUE 5C50	0150-0008
A1C15	C: FXD FLM 0.1 UF 10% 80 VDC SPRAGUE 192P	0120-0002
A1C16	C: FXD CER 0.01 UF 100 VDC SPRAGUE TGS10	0150-0007
A1C17	C: FXD MICA 250 PF 5% 500 VDC ELMENCO DM15	0140-0001
A1CR1,CR2	DIODE: SILICON 1N4446	1900-0002
A1CR3	DIODE: GERMANIUM 1N541	1900-0001
A1L1	INDUCTOR: VAR OSCILLATOR	9140-0001
A1L2	INDUCTOR: VAR TRIPLER	9140-0002
A1Q1,Q2	TRANSISTOR: SILICON 2N3478	1850-0010
A1Q3	TRANSISTOR: SILICON FET	1850-0001
A1R1	R: FXD COMP 3.9K OHM 5% 1/2W RC20GF	0686-3925
A1R2	R: FXD COMP 11K OHM 5% 1/2W RC20GF	0686-1135
A1R3	R: FXD COMP 220 OHM 5% 1/2W RC20GF	0686-2215
A1R4	R: FXD COMP 470 OHM 5% 1/2W RC20GF	0686-4715
A1R5	R: FXD COMP 3.3K OHM 5% 1/2W RC20GF	0686-3325
A1R6	R: FXD COMP 15K OHM 5% 1/2W RC20GF	0686-1535
A1R7	R: FXD COMP 220 OHM 5% 1/2W RC20GF	0686-2215
A1R8	R: FXD COMP 27K OHM 5% 1/2W RC20GF	0686-2735
A1R9	R: FXD COMP 2.4K OHM 5% 1/2W RC20GF	0686-2425
A1R10	R: FXD COMP 1.5K OHM 5% 1/2W RC20GF	0686-1525
A1R11	R: FXD COMP 100 OHM 5% 1/2W RC20GF	0686-1015
A1R12	R: FXD COMP 100 OHM 5% 1/2W RC20GF	0686-1015
A1R13	R: FXD COMP 1K OHM 5% 1/2W RC20GF	0686-1025
A1R14	R: FXD COMP 10K OHM 5% 1/2W RC20GF	0686-1035
A1RFC1	CHOKE: RF 47 UH WILCO W470	9140-0003
A1RFC2 thru RFC4	CHOKE: RF 5.6 UH WILCO W56G	9140-0004
A1RFC5	CHOKE: RF 47 UH WILCO W470	9140-0003
A2 CARD, OSCILLATOR, COUNTER DISCRIMINATOR		
A2C1	C: FXD MICA 12 PF 5% 500 VDC ELMENCO DM15	0140-0007
A2C2	C: VAR CER 5.5-18 PF ERIE 538-011 COPO 92R	0121-0002
A2C3	C: FXD CER 0.01 UF 100 VDC SPRAGUE TGS10	0150-0007
A2C4	C: FXD MICA 620 PF 5% 300 VDC ELMENCO DM15	0140-0009
A2C5	C: FXD MICA 250 PF 5% 500 VDC ELMENCO DM15	0140-0001
A2C6	C: FXD CER 0.01 UF 100 VDC SPRAGUE TGS10	0150-0007
A2C7	C: FXD CER 0.01 UF 100 VDC SPRAGUE TGS10	0150-0007
A2C8	C: FXD CER 1.0 UF 25 VDC SPRAGUE 5C13	0150-0002
A2C9	C: FXD FLM 0.1 UF 10% 80 VDC SPRAGUE 192P	0120-0002
A2C10	C: FXD CER 0.01 UF 100 VDC SPRAGUE TGS10	0150-0007
A2C11	C: FXD CER 0.01 UF 100 VDC SPRAGUE TGS10	0150-0007
A2C12	C: FXD MICA 27 PF 5% 500 VDC ELMENCO DM15	0140-0005
A2C13	C: FXD MICA 250 PF 5% 500 VDC ELMENCO DM15	0140-0001
A2C14	C: FXD MICA 180 PF 5% 500 VDC ELMENCO DM15	0140-0010
A2C15	C: FXD CER 1.0 UF 25 VDC SPRAGUE 5C13	0150-0002
A2C16	C: FXD PORC 130 PF 2% VITRAMON VY10CA131G	0160-0001
A2C17	C: FXD MICA 10 PF 5% 500 VDC ELMENCO DM15	0140-0011

REFERENCE DESIGNATION	DESCRIPTION	PART NUMBER
A2C18	C: FXD CER 0.1 UF 50 VDC SPRAGUE 5C50	0150-0008
A2C19	C: FXD CER 1.0 UF 25 VDC SPRAGUE 5C13	0150-0002
A2C20	C: FXD CER 1.0 UF 25 VDC SPRAGUE 5C13	0150-0002
A2C21	C: FXD ELECT 100 UF 25 VDC SPRAGUE 30D	0180-0003
A2C22	C: FXD CER 0.01 UF 1000 VDC AUTOMATIC COMPONENTS	0150-0003
A2C23	C: FXD ELECT 200 UF 12 VDC SPRAGUE 30D	0180-0004
A2C24	C: FXD CER 1.0 UF 25 VDC SPRAGUE 5C13	0150-0002
A2C25	C: FXD FLM 0.22 UF 10% 80 VDC SPRAGUE 192P	0120-0003
A2C26	C: FXD MYLAR 2.0 UF 200 VDC AEROVOX P8292ZN14	0135-0001
A2C27	C: FXD FLM 0.22 UF 10% 80 VDC SPRAGUE 192P	0120-0003
A2C28	C: FXD ELECT 50 UF 25 VDC SPRAGUE 30D	0180-0005
A2C29	C: FXD ELECT 50 UF 25 VDC SPRAGUE 30D	0180-0005
A2C30	C: FXD FLM 0.22 UF 10% 80 VDC SPRAGUE 192P	0120-0003
A2C31	C: FXD CER 0.1 UF 50 VDC SPRAGUE 5C50	0150-0008
A2CR1 thru CR4	DIODE: GERMANIUM 1N541	1900-0001
A2CR5	DIODE: ZENER 1N825	1900-0005
A2CR6 thru CR8	DIODE: SILICON 1N4446	1900-0002
A2CR9	DIODE: ZENER 1N753A	1900-0006
A2FL1	FILTER: LOWPASS BELAR	9120-0001
A2Q1	TRANSISTOR: SILICON 2N914	1850-0006
A2Q2,Q3	TRANSISTOR: SILICON 2N914 (Matched Pair)	1850-0002
A2Q4 thru Q6	TRANSISTOR: SILICON 2N914	1850-0006
A2Q7	TRANSISTOR: SILICON 2N4037	1850-0011
A2Q8,A2Q9	TRANSISTOR: SILICON 2N914	1850-0006
A2Q10	TRANSISTOR: SILICON 2N4037	1850-0011
A2Q11,Q12	TRANSISTOR: SILICON 2N3053	1850-0008
A2Q13,Q17	TRANSISTOR: SILICON FET (Matched Pair)	1850-0003
A2Q14,Q15	TRANSISTOR: SILICON 2N2102 (Matched Pair)	1850-0004
A2Q16	TRANSISTOR: SILICON 2N2102	1850-0007
A2Q18,Q19	TRANSISTOR: SILICON 2N3053	1850-0008
A2Q20	TRANSISTOR: SILICON 2N2102	1850-0007
A2R1	R: FXD COMP 47K OHM 5% 1/2W RC20GF	0686-4735
A2R2	R: FXD COMP 47K OHM 5% 1/2W RC20GF	0686-4735
A2R3	R: FXD COMP 12K OHM 5% 1/2W RC20GF	0686-1235
A2R4	R: FXD COMP 220 OHM 5% 1/2W RC20GF	0686-2215
A2R5	R: FXD COMP 2K OHM 5% 1/2W RC20GF	0686-2025
A2R6	R: FXD COMP 10K OHM 5% 1/2W RC20GF	0686-1035
A2R7	R: FXD COMP 10K OHM 5% 1/2W RC20GF	0686-1035
A2R8	R: FXD COMP 5.1K OHM 5% 1/2W RC20GF	0686-5125
A2R9	R: FXD COMP 5.1K OHM 5% 1/2W RC20GF	0686-5125
A2R10	R: FXD COMP 10K OHM 5% 1/2W RC20GF	0686-1035
A2R11	R: FXD COMP 510 OHM 5% 1/2W RC20GF	0686-5115
A2R12	R: FXD COMP 1K OHM 5% 1/2W RC20GF	0686-1025
A2R13	R: FXD COMP 10K OHM 5% 1/2W RC20GF	0686-1035
A2R14	R: FXD COMP 3.9K OHM 5% 1/2W RC20GF	0686-3925
A2R15	R: FXD COMP 1.2K OHM 5% 1/2W RC20GF	0686-1225
A2R16	R: FXD COMP 2.2K OHM 5% 1/2W RC20GF	0686-2225
A2R17	R: FXD COMP 20K OHM 5% 1/2W RC20GF	0686-2035
A2R18	R: FXD COMP 390 OHM 5% 1/2W RC20GF	0686-3915
A2R19	R: FXD COMP 3.9K OHM 5% 1/2W RC20GF	0686-3925
A2R20	R: FXD COMP 39 OHM 5% 1/2W RC20GF	0686-3905
A2R21	R: FXD COMP 2.2K OHM 5% 1/2W RC20GF	0686-2225
A2R22	R: FXD COMP 620 OHM 5% 1/2W RC20GF	0686-6215
A2R23	R: FXD COMP 1.8K OHM 5% 1/2W RC20GF	0686-1825
A2R24	R: FXD FLM 2.21K OHM 1% 1/8W RN60D	0757-0001
A2R25	R: FXD FLM 1K OHM 1% 1/8W RN60D	0757-0002
A2R26	R: FXD COMP 1.1K OHM 5% 1/2W RC20GF	0686-1125
A2R27	R: FXD FLM 10K OHM 1% 1/8W RN60D	0757-0003

REFERENCE DESIGNATION	DESCRIPTION	PART NUMBER
A2R28	R: FXD FLM 2.21K OHM 1% 1/8W RN60D	0757-0001
A2R29	R: FXD FLM 1K OHM 1% 1/8W RN60D	0757-0002
A2R30	R: FXD WW 1K OHM 1% 1/2W IRC AS1/2	0811-0009
A2R31	R: FXD COMP 1K OHM 10% 1W RC32GF	0690-1021
A2R32	R: FXD FLM 1K OHM 1% 1/8W RN60D	0757-0002
A2R33	R: FXD COMP 68 OHM 5% 1/2W RC20GF	0686-6805
A2R34	R: FXD COMP 1.3K OHM 5% 1/2W RC20GF	0686-1325
A2R35	R: FXD COMP 5.1K OHM 5% 1/2W RC20GF	0686-5125
A2Y1	CRYSTAL: 650 kHz	0410-0003
A3 CARD, AMPLIFIER, METERING AND FLASHER		
A3C1	C: FXD ELECT 100 UF 15 VDC SPRAGUE 30 D	0180-0006
A3C2	C: FXD ELECT 50 UF 25 VDC SPRAGUE 30D	0180-0005
A3C3	C: FXD ELECT 50 UF 25 VDC SPRAGUE 30D	0180-0005
A3C4	C: FXD ELECT 100 UF 15 VDC SPRAGUE 30D	0180-0006
A3C5	C: FXD ELECT 5 UF 25 VDC SPRAGUE 30D	0180-0007
A3C6	C: FXD ELECT 50 UF 25 VDC SPRAGUE 30D	0180-0005
A3C7	C: FXD FLM 0.22 UF 10% 80 VDC SPRAGUE 192P	0120-0003
A3C8	C: FXD CER 1.0 UF 25 VDC SPRAGUE 5C13	0150-0002
A3C9	C: FXD MICA 250 PF 5% 500 VDC ELMENCO DM15	0140-0001
A3C10	C: FXD ELECT 50 UF 25 VDC SPRAGUE 30D	0180-0005
A3C11	C: FXD MICA 120 PF 5% 500 VDC ELMENCO DM15	0140-0002
A3C12	C: FXD MICA 250 PF 5% 500 VDC ELMENCO DM15	0140-0001
A3C13	C: FXD ELECT 100 UF 15 VDC SPRAGUE 30D	0180-0006
A3C14	C: FXD ELECT 100 UF 15 VDC SPRAGUE 30D	0180-0006
A3C15	C: FXD ELECT 200 UF 12 VDC SPRAGUE 30D	0180-0004
A3C16	C: FXD ELECT 50 UF 25 VDC SPRAGUE 30D	0180-0005
A3C17	C: FXD ELECT 5 UF 25 VDC SPRAGUE 30D	0180-0007
A3C18	C: FXD CER 0.1 UF 50 VDC SPRAGUE 5C50	0150-0008
A3C19	C: FXD ELECT 50 UF 25 VDC SPRAGUE 30D	0180-0005
A3C20	C: FXD FLM 0.047 UF 10% 200 VDC SPRAGUE 192P	0120-0004
A3C21	C: FXD ELECT 5 UF 25 VDC SPRAGUE 30D	0180-0007
A3C22	C: FXD FLM 0.1 UF 10% 80 VDC SPRAGUE 192P	0120-0002
A3C23	C: FXD ELECT 50 UF 25 VDC SPRAGUE 30D	0180-0005
A3C24	C: FXD MICA 360 PF 5% 500 VDC ELMENCO DM15	0140-0012
A3CR1	DIODE: SILICON 1N4446	1900-0002
A3CR2	DIODE: ZENER 1N965B	1900-0007
A3CR3 thru CR5	DIODE: SILICON 1N4446	1900-0002
A3Q1 thru Q4	TRANSISTOR: SILICON 2N3053	1850-0008
A3Q5	TRANSISTOR: SILICON FET	1850-0001
A3Q6 thru Q15	TRANSISTOR: SILICON 2N3053	1850-0008
A3Q16	TRANSISTOR: SILICON 2N4037	1850-0011
A3Q17	TRANSISTOR: SILICON 2N3053	1850-0005
A3Q18	TRANSISTOR: SILICON 2N3053	1850-0005
A3R1	R: FXD COMP 10K OHM 5% 1/2W RC20GF	0686-1035
A3R2	R: FXD COMP 20K OHM 5% 1/2W RC20GF	0686-2035
A3R3	R: FXD COMP 510 OHM 5% 1/2W RC20GF	0686-5115
A3R4	R: FXD COMP 360 OHM 5% 1/2W RC20GF	0686-3615
A3R5	R: VAR WW 300 OHM CTS 110-300	2100-0004
A3R6	R: FXD COMP 100K OHM 5% 1/2W RC20GF	0686-1045
A3R7	R: FXD COMP 100K OHM 5% 1/2W RC20GF	0686-1045
A3R8	R: FXD COMP 100K OHM 5% 1/2W RC20GF	0686-1045
A3R9	R: FXD COMP 4.7K OHM 5% 1/2W RC20GF	0686-4725
A3R10	R: FXD COMP 47K OHM 5% 1/2W RC20GF	0686-4735

REFERENCE DESIGNATION	DESCRIPTION	PART NUMBER
A3R11	R: FXD COMP 3.3K OHM 5% 1/2W RC20GF	0686-3325
A3R12	R: FXD COMP 240 OHM 5% 1/2W RC20GF	0686-2415
A3R13	R: FXD COMP 1.5K OHM 5% 1/2W RC20GF	0686-1525
A3R14	R: FXD COMP 4.7K OHM 5% 1/2W RC20GF	0686-4725
A3R15	R: VAR WW 3K OHM CTS 110-3000	2100-0005
A3R16	R: FXD COMP 24K OHM 5% 1/2W RC20GF	0686-2435
A3R17	R: FXD COMP 3.3K OHM 5% 1/2W RC20GF	0686-3325
A3R18	R: FXD COMP 330 OHM 5% 1/2W RC20GF	0686-3315
A3R19	R: FXD COMP 1K OHM 5% 1/2W RC20GF	0686-1025
A3R20	R: FXD COMP 8.2M OHM 5% 1/2W RC20GF	0686-8255
A3R21	R: FXD COMP 10K OHM 5% 1/2W RC20GF	0686-1035

SECTION 7 SCHEMATIC DIAGRAMS

Section 7 contains circuit diagrams of the printed circuit card assemblies and chassis assembly. Note that all part numbers are prefixed by the assembly number (e.g. A2R34). The main chassis part numbers are not prefixed. Non-standard parts are labeled with only the reference designations. The parts list in Section 6 contains the Belar part number.

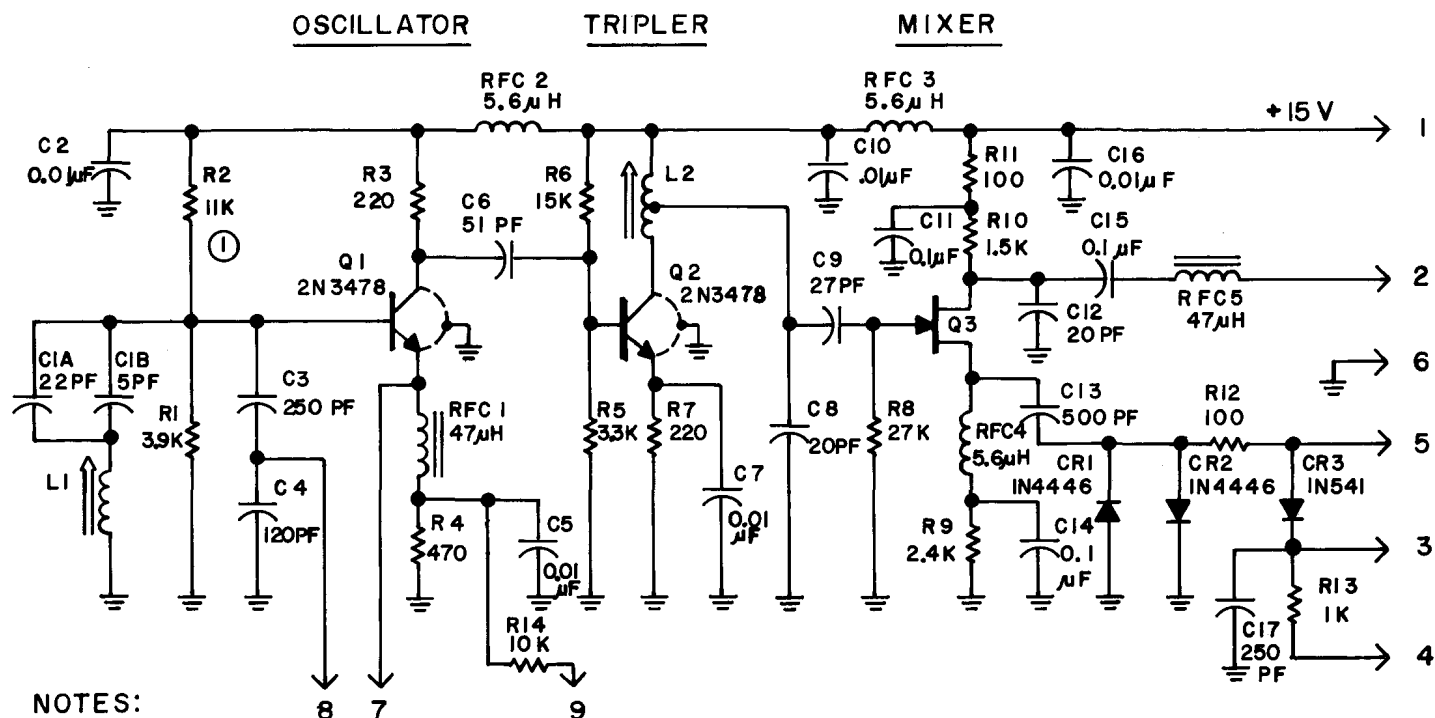

LAST R 14
 C 17
 L 2
 CR 3
 Q 3
 RFC 5

Figure 7-1. Oscillator, Tripler and Mixer Card A1, Schematic

ZERO AXIS LIMITER

SCHMITT TRIGGER

MONOSTABLE MULTIVIB

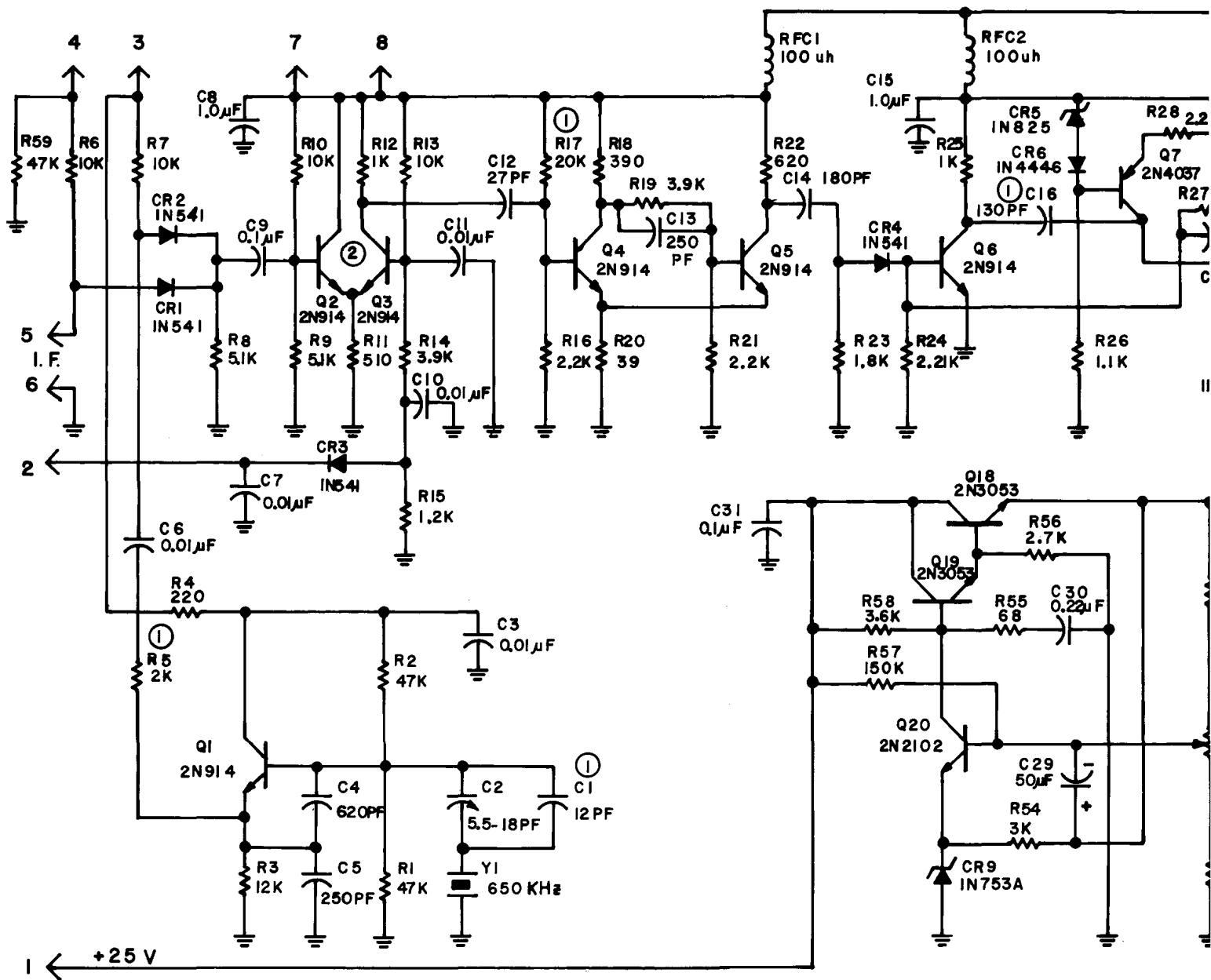

CALIBRATING OSCILLATOR

15 VOLT REGULATOR

NOTES:

- ALL RESISTANCE VALUES ARE IN OHMS.
- ① VALUE SELECTED IN PRODUCTION, NOMINAL VALUE SHOWN.
- ② MATCHED PAIR.
- ALL PART NUMBERS ARE PREFIXED BY THE ASSEMBLY NUMBER (e.g. A2R34).

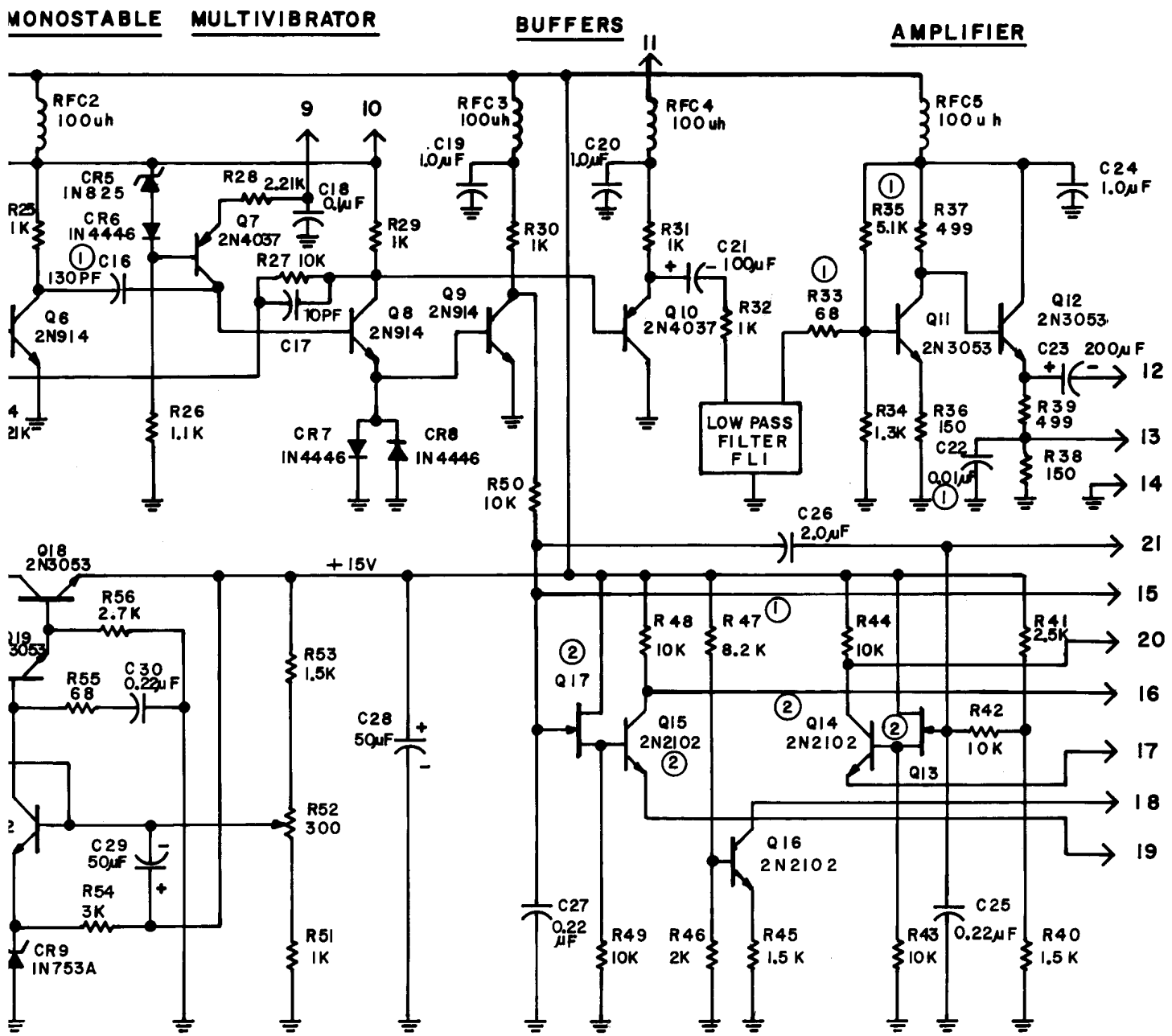

LAST	R	59
	C	31
	RFC	5
	CR	9
	Q	20
	FL	1
	Y	1

Figure 7-2. Oscillator, Counter and Amplifier Card A2, Schematic

PHASE SPLITTER

AMPLIFIER

PEAK

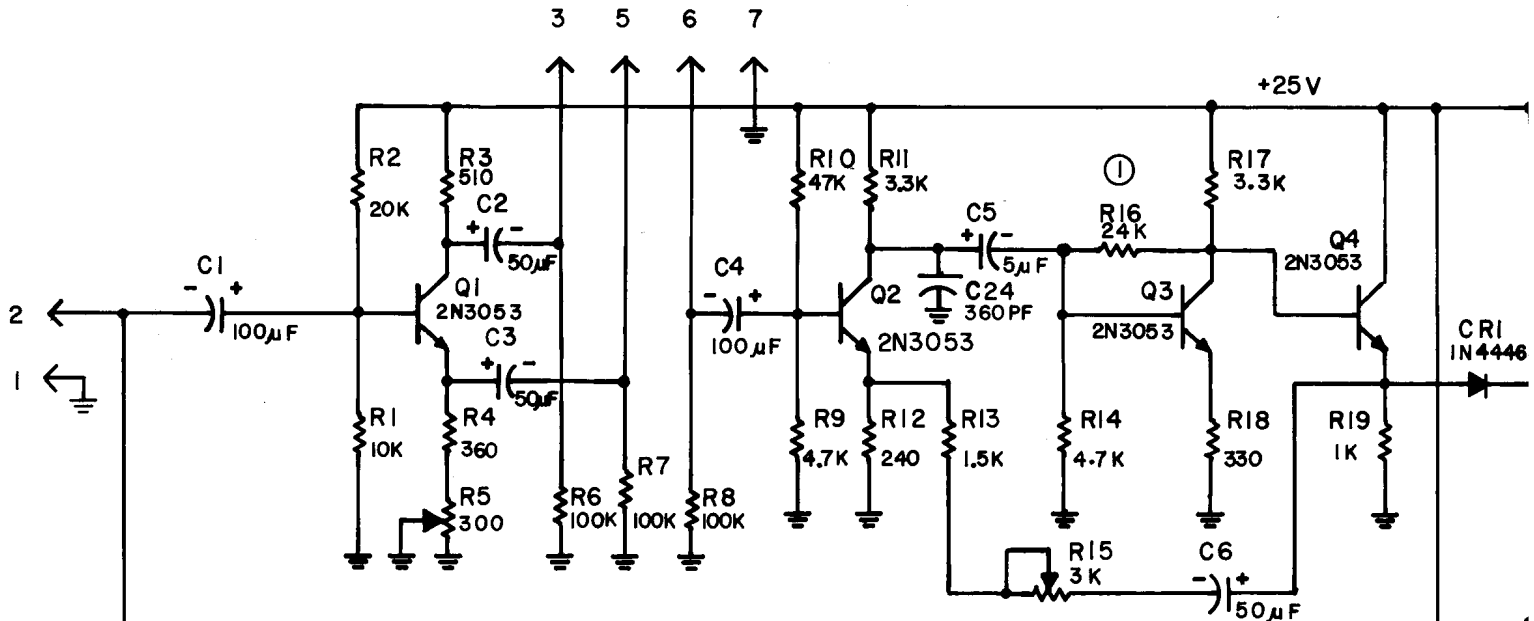

MONITOR AMPLIFIER

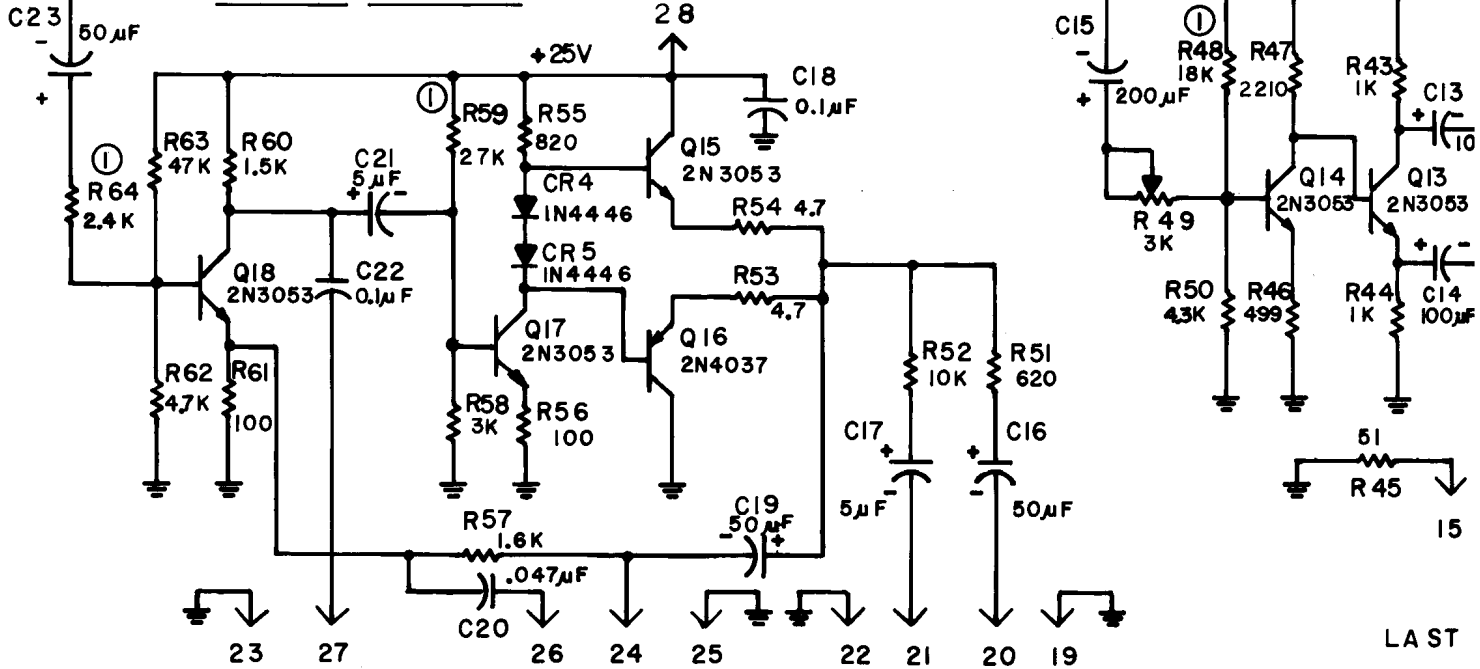

NOTES:

ALL RESISTANCE VALUES ARE IN OHMS.

① VALUE SELECTED IN PRODUCTION, NOMINAL VALUE SHOWN.

② MATCHED PAIR.

ALL PART NUMBERS ARE PREFIXED BY THE ASSEMBLY NUMBER (eg. A3C12)

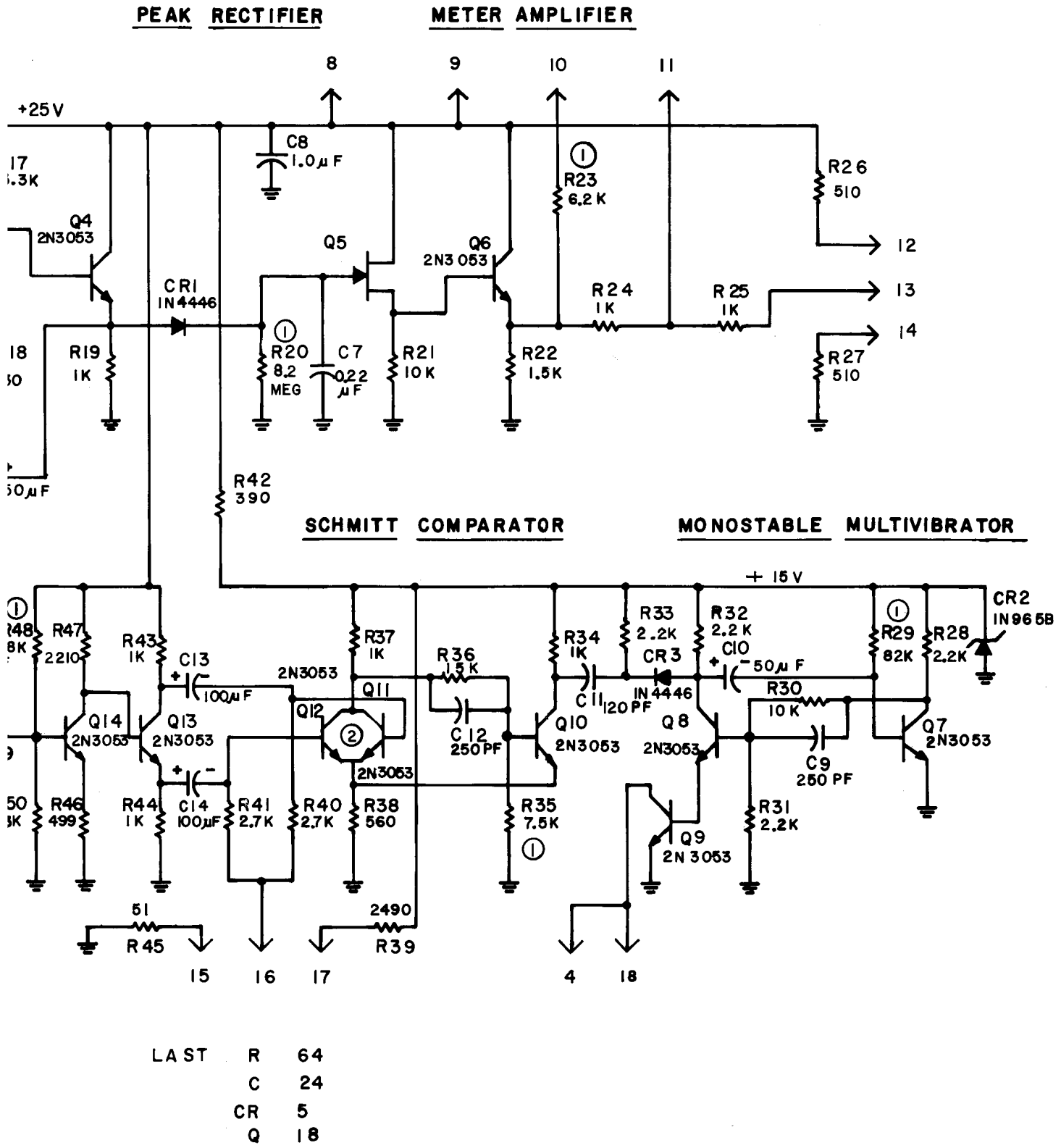

.A3C12)

Figure 7-3. Amplifier, Metering and Flasher Card A3, Schematic

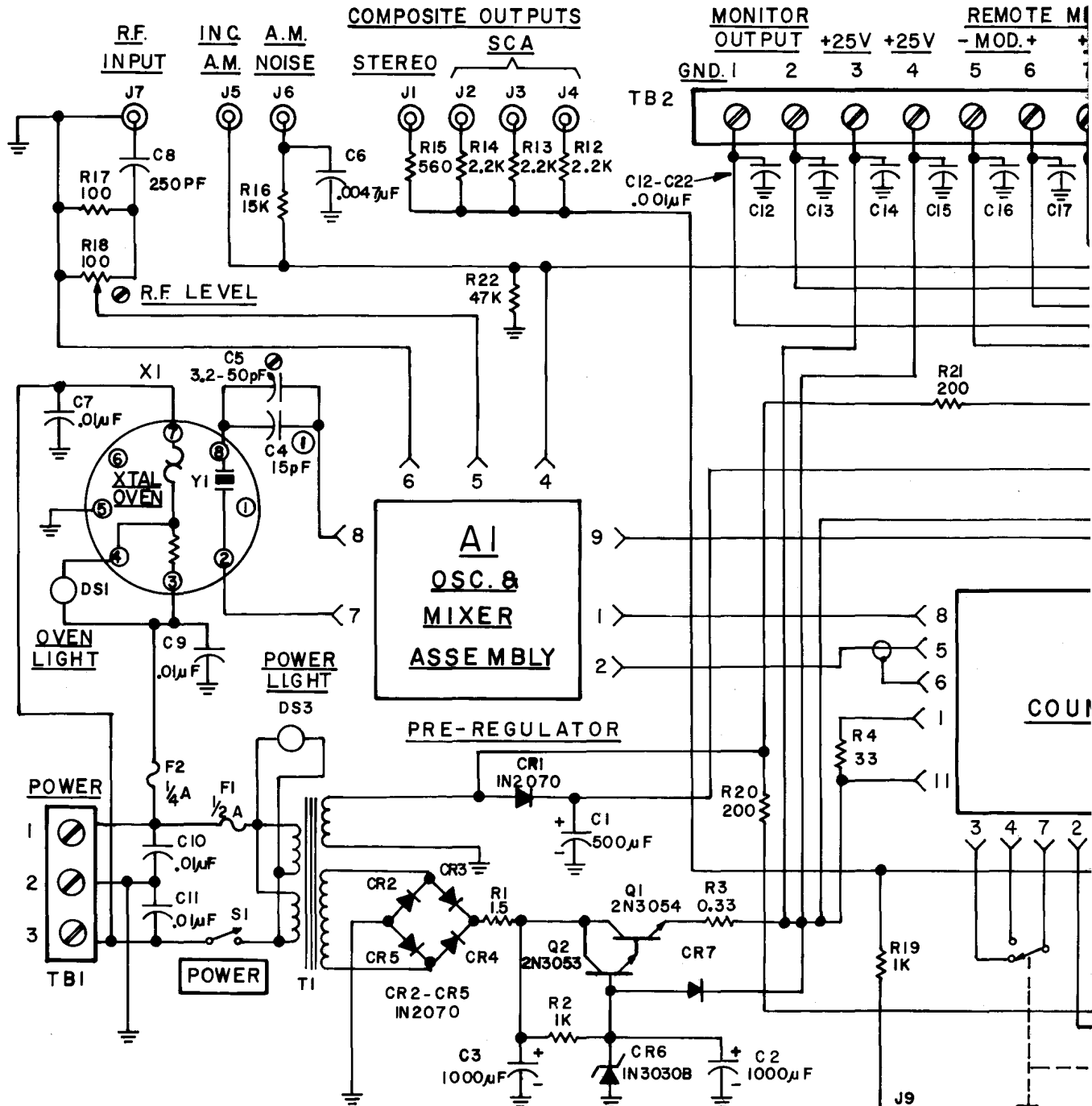

NOTES:

ALL RESISTANCE VALUES ARE IN OHMS.
 ① VALUE SELECTED IN PRODUCTION, NOMINAL VALUE SHOWN

LAST R	23	LAST Y	1	LAST M	2
C	22	X	1	F	2
CR	7	T	1	S	7
Q	2	DS	3	J	9

WIDE BAND TEST

OP.

S2 (SHOWN)

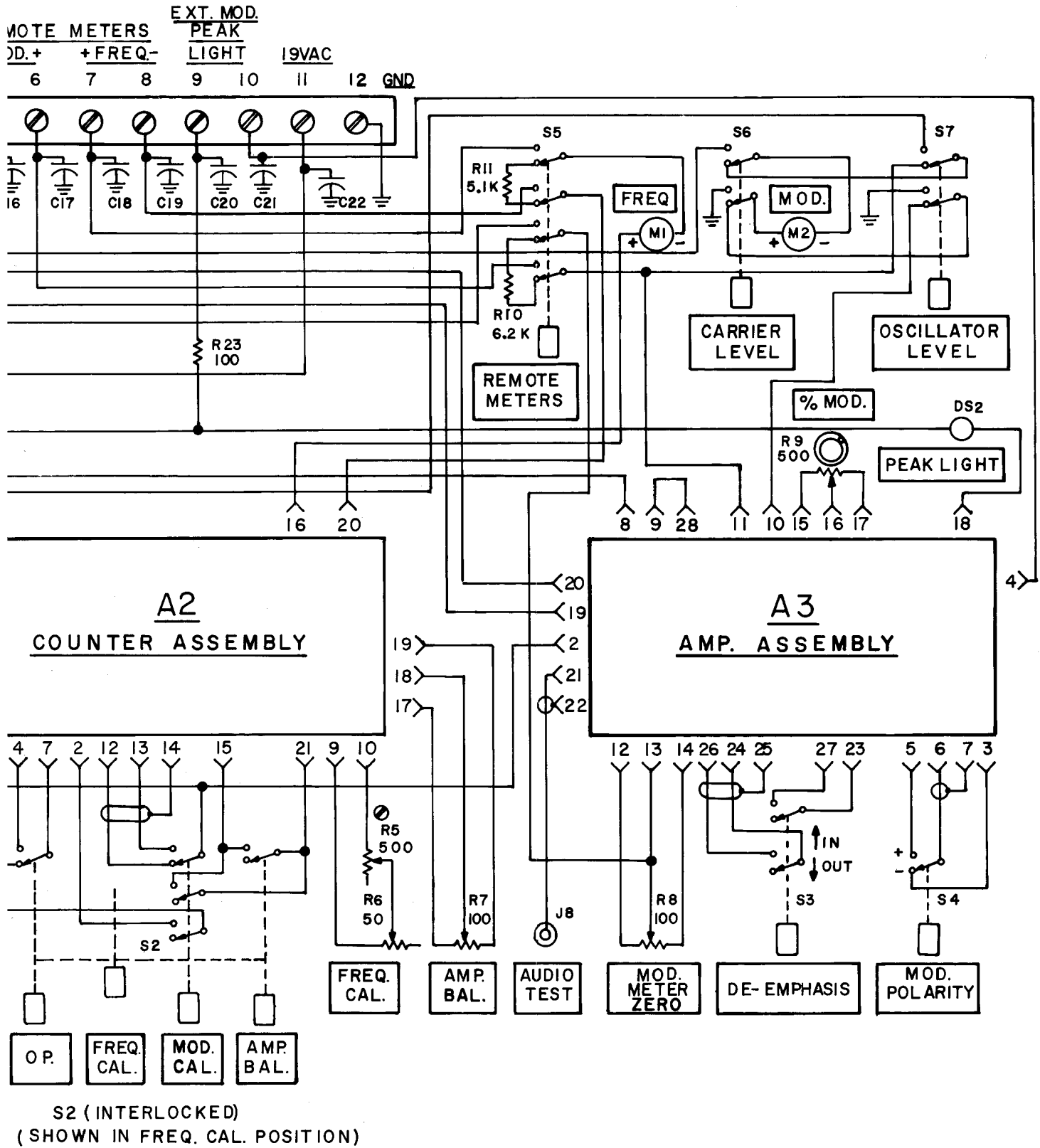

Figure 7-4. FMM-1 Frequency and Modulation Monitor Chassis, Schematic



BELAR ELECTRONICS LABORATORY, INC.