

Dec. 26, 1933.

E. H. ARMSTRONG

1,941,068

RADIO SIGNALING

Filed Jan. 24, 1933

3 Sheets-Sheet 1

Fig. 1.

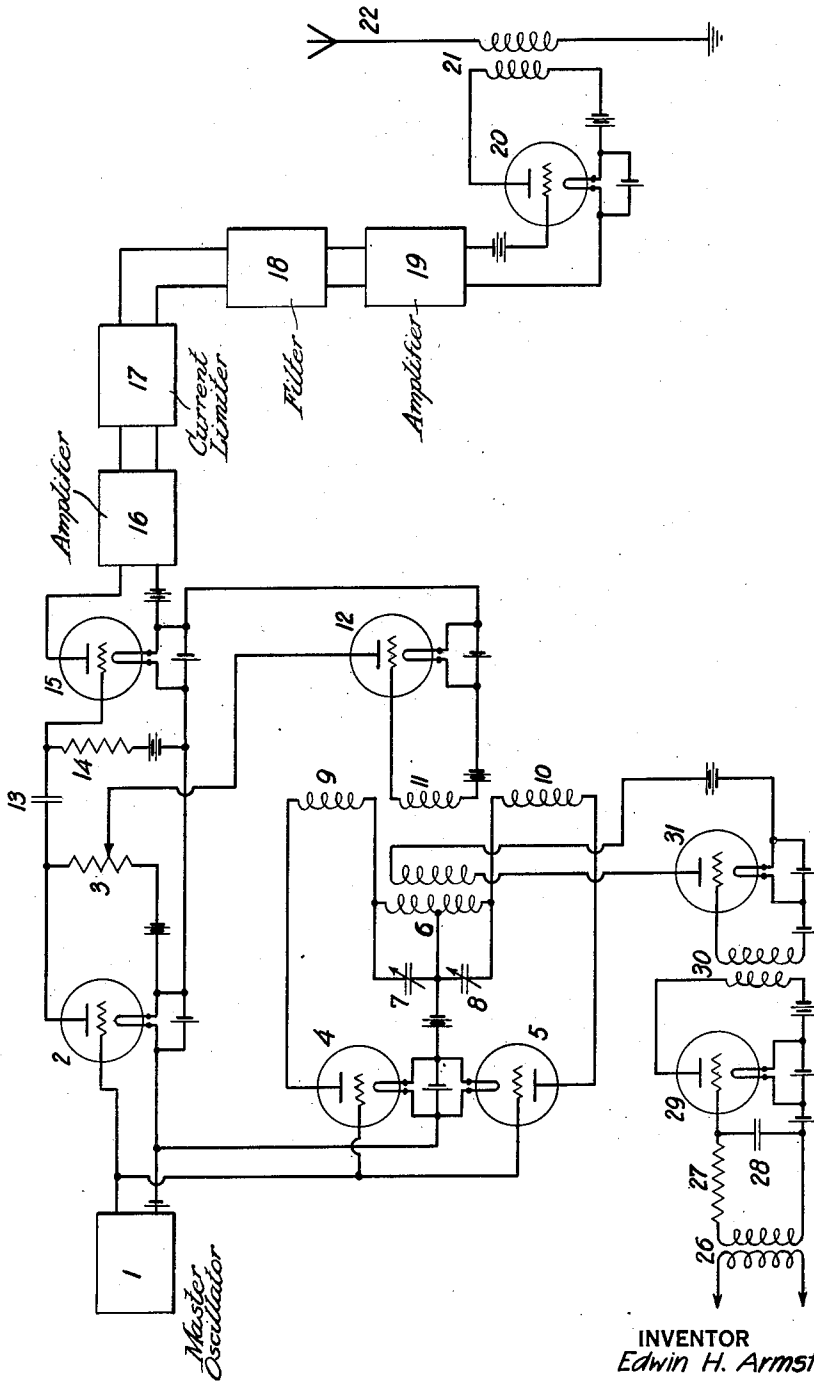

INVENTOR
Edwin H. Armstrong.
BY *Moses & Nolte*
ATTORNEYS

Dec. 26, 1933.

E. H. ARMSTRONG

1,941,068

RADIO SIGNALING

Filed Jan. 24, 1933

3 Sheets-Sheet 2

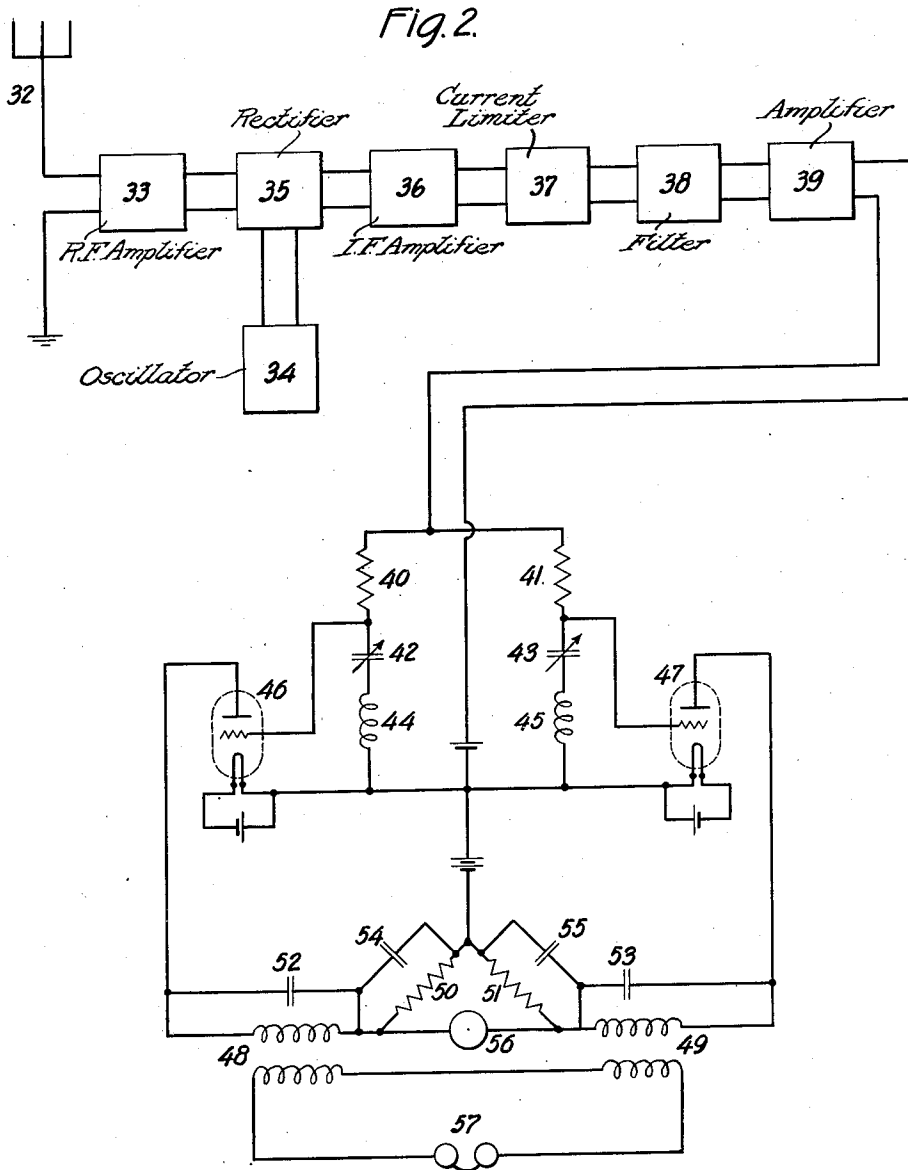

INVENTOR
Edwin H. Armstrong.
BY *Moses & Nolte.*
ATTORNEYS

Dec. 26, 1933.

E. H. ARMSTRONG

1,941,068

RADIOSIGNALING

Filed Jan. 24, 1933

3 Sheets-Sheet 3

Fig. 4.

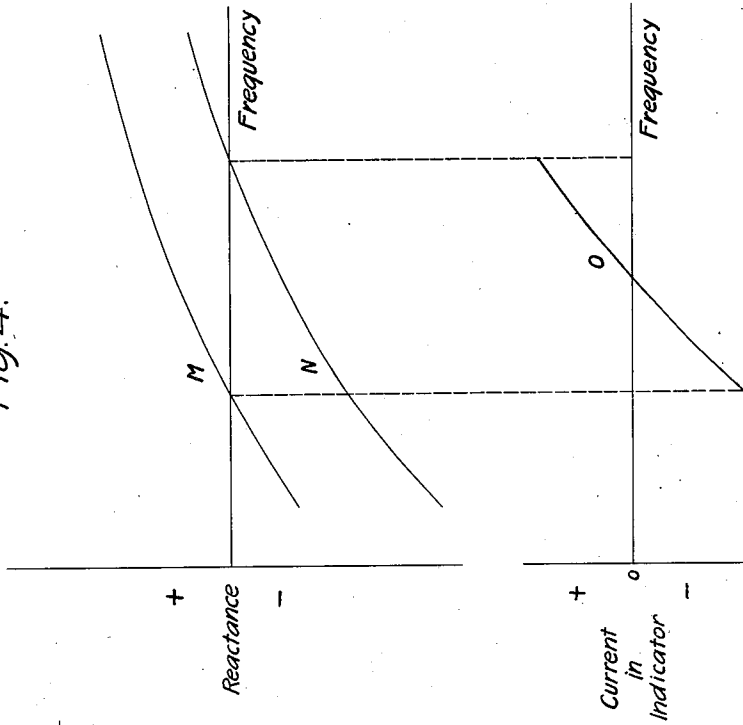
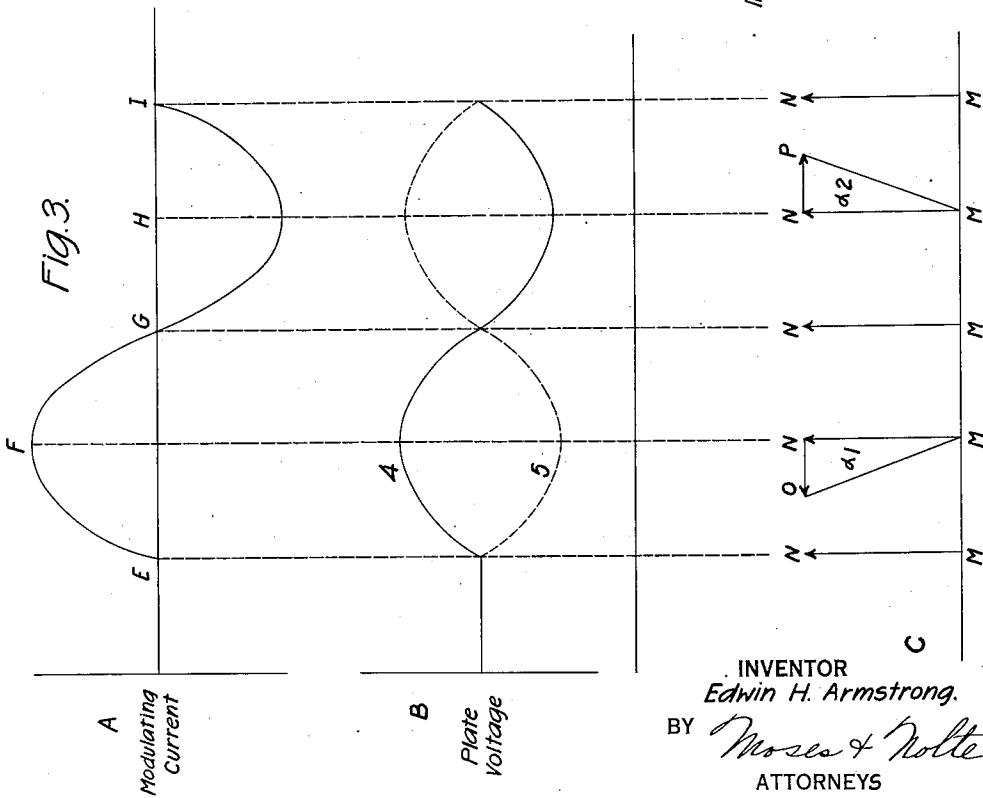

Fig. 3.



INVENTOR
Edwin H. Armstrong.
BY *Moses & Nolte*
ATTORNEYS

UNITED STATES PATENT OFFICE

1,941,068

RADIO SIGNALING

Edwin H. Armstrong, New York, N. Y.

Application January 24, 1933. Serial No. 653,236

5 Claims. (Cl. 250-6)

This invention relates to a method of signaling in radio communication by means of the modulation of the frequency of the transmitted wave.

The object of the invention is to provide a system in which the frequency and phase of the current generated by the master oscillator of the transmitter remains fixed and the frequency variation of the transmitted wave is obtained by phase shifting and frequency correction devices as hereinafter described.

A further object of the invention is to provide a system in which both the production of the variable frequency currents of the transmitted wave and the translation of the variations of frequency of the received wave to reproduce the signaling currents are accomplished by aperiodic means, (that is, without the use of resonant circuits and therefore without the creation of transient oscillations therein).

Fig. I illustrates the general arrangement of the transmitting system. Fig. II illustrates the general arrangement of the receiving system. Figs. III and IV illustrate certain diagrams showing the phase relations in the system as hereinafter set forth.

Referring now to Fig. I, 1 represents a constant frequency oscillator, preferably crystal controlled, 2 an amplifier of the output of this oscillator with a resistance 3 in its plate circuit which is small in comparison with the impedance of the tube. 4 and 5 are likewise amplifiers of the output of the master oscillator 1. 6 is a transformer for differentially modulating the plate voltages of the tubes 4 and 5 by the signaling current which is applied to the primary of the transformer. 7 and 8 are condensers shunting the two halves of the secondary of the transformer 6. 9 and 10 are inductances whose impedance for the frequency of the oscillator is small compared to the impedance of the tubes 4 and 5. 11 is a small inductance whose natural frequency is high compared to the frequency of the oscillator. It is coupled differentially to the coils 9 and 10. 12 is an amplifier for amplifying the output of tubes 4 and 5. Its plate is connected as shown to an adjustable point on the resistance in the plate circuit of the amplifier 2. The combined outputs of the tubes 2 and 12 are supplied to an amplifier 15, 16 whose output passes thru a current limiter 17, filter 18, and to a frequency multiplier 19, power amplifier 20 and antenna 22.

The operation of the system is as follows: The E. M. F. of the oscillator output is impressed upon the grid of the amplifier 2 and a current of the

same frequency is thereby created in the plate circuit of the amplifier. This current is in phase with the E. M. F. impressed upon the grid since the impedance in the plate circuit is pure resistance and the frequency which is chosen to start with is such that tube capacity is of negligible importance. A voltage drop is thereby produced across the plate resistance and the phase of this voltage is 180° from that of the E. M. F. impressed upon the grid.

The same E. M. F. impressed upon the grid of the amplifier 2 is also impressed upon the grids of tubes 4 and 5 and it is impressed in the same phase since all three grids are in parallel. By choosing the reactances of coils 9 and 10 to be small compared to the impedance of the tubes 4 and 5 and by adjusting condensers 7 and 8 to balance out the reactances of 9 and 10 the current set up in the plate circuits of the tubes 4 and 5 can be brought into phase with the E. M. F. impressed upon the grids. The E. M. F.'s induced in the coil 11 by the currents in the coils 9 and 10 are 90° out of phase with the currents in these coils. Hence the E. M. F. induced in coil 11 by the current in either 9 or 10 is 90° out of phase with the E. M. F. applied to the grids of tubes 2, 4 and 5. The E. M. F. in coil 11 may be either 90° ahead or 90° behind the E. M. F. applied to the grids of these tubes, depending upon the polarity of coils 9 and 10 with respect to coil 11. This coil is differentially coupled to coils 9 and 10 so that when the plate circuits of tubes 4 and 5 are not being modulated the E. M. F. induced in the coil is zero.

Now when the plate voltage of tube 4 for example is raised and the plate voltage of tube 5 correspondingly lowered by modulation from the transformer 6 there will be set up in coil 11 an E. M. F. 90° ahead or 90° behind the E. M. F. applied to the grid of the amplifier 2. Similarly when the plate voltage of tube 4 is lowered and that of tube 5 is raised there is induced in coil 11 an E. M. F. which is either 90° behind or 90° ahead of the E. M. F. applied to the grid of the amplifier 2. We will assume for the purpose of this explanation that the coil 11 is so poled with respect to coils 9 and 10 that when the plate voltage of tube 4 is raised and that of tube 5 lowered that the voltage induced in coil 11 is 90° ahead of the voltage applied to the grid of tube 2, and that when the plate voltage of 4 is lowered and that of tube 5 raised that the voltage induced in 11 is 90° behind the grid voltage of tube 2.

With this assumption refer now to Fig. III. This figure illustrates by the vector combination

of voltages how the frequency is alternately increased and decreased. A represents the modulating current in transformer 6, B the plate voltages (of modulation frequency) of tubes 4 and 5, and C the vector combinations of radio frequency voltages produced in the plate circuit of tube 2. The conditions existing in the system when the modulating current is zero are illustrated by point E in curve A. When this current is zero the plate voltages on tubes 4 and 5 are equal, there is no voltage induced in coil 11 and the only voltage across the plate circuit resistance 3 of tube 2 is that due to the voltage on its own grid. This is illustrated for this condition by the vector MN. When there is current in the transformer 6 as illustrated in curve A by point F then the plate voltages (of modulating frequency) of tubes 4 and 5 are unequal as illustrated in curve B. There is therefore induced in coil 11 an E. M. F. 90° ahead of the phase of the E. M. F. applied to the grid of tube 2 and therefore 90° behind the phase of the voltage across resistance 3 in the plate circuit, which is represented in graph C by the vector MN. The E. M. F. induced in coil 11 is applied to the grid of the amplifier 12 and produces in its plate circuit a current in phase with it. This current produces across that part of the resistance 3 which is in the plate circuit of tube 12 an E. M. F. 180° out of phase with the E. M. F. induced in coil 11 and therefore 90° ahead in phase of the E. M. F. produced across the resistance 3 by the tube 2. The quadrature voltage is illustrated by ON and the combination of these two voltages create a new voltage MO which has moved forward in phase ahead of the original voltage MN by an angle α_1 , which depends on the ratio of the two voltages which compose it. When point G in curve A is reached the conditions of point E are restored and the only voltage existing across resistance 3 is that illustrated by the vector MN. When point H is reached conditions exactly the reverse of those of point F obtain and the vector PN represents the voltage produced across that part of the resistance 3 which is in the plate circuit of tube 12 and which is 90° behind the vector MN. The new voltage MP therefore lags behind the voltage MN by an angle α_2 which depends on the ratio of the two voltages composing it and which is equal to the angle α_1 .

It will be seen, therefore, that the action of the system 4, 5, 12 is alternately to advance and to retard the phase of the E. M. F. applied to the grid of tube 15 with respect to the phase of the constant frequency oscillator 1. Hence the frequency of the E. M. F. applied to the grid of tube 15 is alternately increased above and decreased below the frequency of the constant frequency oscillator 1. The rate of change is in accordance with the frequency of the modulating current in the transformer 6 and the extent of the change depends on the ratio of the E. M. F. produced across the resistance 3 by the tube 12 to the E. M. F. produced across it by the tube 2. In order to maintain proportionality between the amplitude of the modulating current and the angle of phase shift it is necessary to keep the quadrature voltage produced by the tube 12 small with respect to the voltage produced by the tube 2. If the maximum voltage produced across the resistance 3 by the tube 12 on the peak of any modulation is less than 58% of the steady value of the voltage produced across the resistance by the tube 2, then the angle of phase shift will be under 30° . Under these conditions the angle of phase shift will be approximately proportional to the voltage produced by the modulating system—which in turn is directly proportional to the voltage applied to the input of the amplifying tubes controlling the modulating system. This is because the sine of the angle α , which represents the modulating voltage produced across the resistance, and the angle α , which represents the angle of the phase shift, are for all practical purposes directly proportional for values of less than 30° . Since the time taken to shift the phase is inversely proportional to the frequency of modulation, it follows that the rate of change in frequency of the E. M. F. applied to the grid of the tube 15 is, for constant impressed modulating voltage, directly proportional to the frequency of the modulating current. Hence in order to produce a change in carrier frequency, which is constant over all ranges of modulating frequency, it is necessary to introduce a correction system in the modulation input which produces a voltage applied to the transformer 6 which is inversely proportional to frequency. That is, for a constant value of modulating E. M. F. applied to the input of the system the angle of phase shift which is produced must be inversely proportional to the frequency of the modulating E. M. F. This is accomplished by means of the resistance, condenser combination 27, 28 in which a resistance 27 which is high compared to the impedance of the condenser 28 for the frequencies of modulation is connected in series across the secondary of the transformer 26 and the voltage drop across the condenser applied to the grid of the amplifier 29. A second amplifying stage 30, 31 raises the corrected voltage to a level sufficient to operate the modulating system.

In order to maintain proportionality i. e., freedom from distortion between the frequency shift and the amplitude of the modulating current it is not advisable to produce a shift of greater than 30° in the angle α as beyond this value an increasing distortion is encountered. The lowest frequency of modulation, at which, by reason of the correction system 27, 28 the greatest voltage is applied to the modulators, is therefore limited to a 30 degree phase shift. Now in order to produce an effective change in frequency commensurate with that which is obtainable from the ordinary method of varying the frequency of an oscillator (that is, to produce 100% modulation) it is necessary at the lower frequencies of modulation to produce a phase shift which corresponds to many complete revolutions. That is, if we assume that 5000 cycles, for example, is the highest frequency of modulation and a phase shift of 45° in the radiated wave is necessary to produce 100% modulation at that modulating frequency, then at 39 cycles a phase shift of 5760° in the radiated wave is required to produce the same degree of modulation. This is accomplished by successive multiplications of frequency so that with each successive doubling the angle of phase shift is doubled or with each tripling the angle is tripled. By properly choosing the initial frequency sufficiently low with respect to the frequency of the wave to be transmitted any desired frequency variation may be produced.

In order to obtain what corresponds in amplitude modulation to complete or 100% modulation it is essential that the phase shift of the transmitted wave for the highest frequency of modulation be of the order of 45° . Therefore the number of multiplications should be sufficient to produce at least this amount of phase shift at

the highest modulation frequency. Assuming, for example, that the lowest frequency of modulation is 39 cycles per second and that there is a maximum phase shift of 30°, then for 78 cycles there will be a phase shift of 15 degrees and for 156 cycles a phase shift of 7.5° etc. until for a 5000 cycle modulating current the phase shift will be only .234 degrees. Now as previously pointed out a phase shift of at least 45° in the transmitted wave at the highest modulating frequency is required in order to produce what corresponds in amplitude signaling to 100% modulation. Therefore the .234 degree phase shift must be multiplied about 192 fold to produce a 45° phase shift in the transmitted wave. This is accomplished by a frequency multiplication system consisting of 5 doublers and 1 tripler which produces the desired increase in the phase shift at 5000 cycles modulation. Correspondingly for a frequency of modulation of 2500 cycles there will be produced a phase shift in the transmitted wave of 90°, for 1250 cycles a phase shift of 180° etc. until at a modulating frequency of 39 cycles there will be produced a phase shift of 5760 degrees or 16 complete revolutions.

In the transmitter illustrated in Fig. 1 the variable frequency E. M. F. applied to the grid of tube 15 is amplified by that tube and the amplifier 16, passed thru a current limiter 17, a filter 18 to remove harmonics, multiplied any desired number of times by the frequency multiplier 19 and then amplified by the power amplifier 20 whose output feeds the antenna 22.

Referring now to Fig. 2 there is illustrated a type of receiver previously described in my pending application Serial No. 192,320, filed May 18, 1927, for Radio telephone signalling. In the arrangement shown 32 represents the receiving antenna, 33 an amplifier of the received frequency, 34 an oscillator, and 35 the first rectifier of a superheterodyne receiving system. 36 represents the intermediate frequency amplifier and 37 a current limiter for removing amplitude fluctuations from the intermediate frequency current. 38 is a filter for removing undesired harmonics created by the current limiter and 39 is an amplifier for the intermediate frequency current to raise it to a sufficient level to produce straight line rectification by the detectors 46, 47. The output of the amplifier 39 is delivered to a selective system consisting of two branch circuits 40, 42, 44 and 41, 43, 45 which are connected respectively to the two detectors 46, 47 as shown. These detectors are biased to cutoff for the purpose of obtaining straight line rectification. The resistances 40 and 41 are made sufficiently large with respect to the reactances of the capacity inductance combinations 42, 44 and 43, 45 to insure the current in the circuit remaining constant thruout the range of variation of the intermediate frequency. The values of capacity and inductance are so chosen that the reactance of one branch is zero at some frequency slightly below the lowest frequency existing in the intermediate frequency system during the swing down and so that the reactance of the other branch is zero at some frequency slightly above the highest frequency existing in the intermediate frequency system during the swing up while at the same time the arithmetic values of reactances for the frequency midway between the two extremes for each branch are equal to each other. 48, 49 are transformers in the output circuits of the detectors and 50, 51 are resistances bridged by an indicating instrument 56 for the purpose of

indicating when the balance is obtained. 52, 53, 54 and 55 are the usual bypass condensers. 57 represents the receiving telephone or other signaling device connected to the secondaries of the transformers 48, 49 which are so poled that rectified currents resulting from amplitude variations in the intermediate frequency current produce opposing voltages in the secondary windings while rectified currents resulting from frequency variations in the intermediate frequency current produce additive voltages in the secondary windings.

The voltage impressed on the grid of one detector tube is proportioned to the reactance curve M of Fig. 4 which represents the combined reactances of the capacity and inductance in one branch circuit. The voltage impressed upon the grid of the other detector tube is proportional to curve N which represents the combined reactance of the capacity and inductance in the other branch circuit. The combined output currents are shown by curve O, which represents the current in the indicator 56. The present arrangement operates substantially in the same manner as the arrangement previously filed except that in the present case the selecting system for translating variations in frequency into variations in amplitude is carried out by two branch circuits each containing capacity and inductance instead of in a single circuit containing two capacities and a single inductance.

It will be observed that in this system the creation of the variation of frequency at the transmitter and the translation of the variations of frequency into amplitude variations at the receiver are both accomplished by aperiodic systems. That is, there is no resonant circuit at the transmitter whose period of oscillation must be varied in order to create a variation in frequency, nor is there any resonant circuit at the receiver whose period of building up and damping down delays the translation of the variations in frequency into variations in amplitude. Therefore the whole operation at both transmitter and receiver is performed aperiodically without difficulty from the presence of transient currents. As a consequence of this the method is applicable to types of communication such as facsimile, television, etc., where the rates of modulation are much higher than in voice transmission.

Where frequencies of modulation substantially higher than that required for voice transmission are employed, such as in television, it is desirable to start with a higher initial frequency at the master oscillator than in the case of sound transmission. It may therefore be difficult to realize the desired number of multiplications of phase shift before the resulting frequency reaches a value higher than that at which it is desired to transmit. This difficulty may be avoided in one of two ways. One is to continue the multiplications of phase shift regardless of the resulting frequency until the desired number of revolutions are obtained and then to heterodyne the resulting frequency down to the desired value, amplify it and transmit it. The other is to multiply the frequency to some value less than the frequency which it is desired to transmit, heterodyne it down to some submultiple of the transmitting frequency, multiply it up again to the transmitting frequency, amplify it and transmit it. The choice of the frequency to which the heterodyning should be carried is determined by

the number of revolutions of phase shift which are desired.

At the receiver, if a frequency of modulation higher than that used for voice transmission is employed the non-reactive points of the two capacity inductance combinations are chosen farther apart and the rest of the system correspondingly designed to accommodate the higher modulation frequencies. Otherwise the action of the system for the transmission of television modulations is the same as for sound modulations.

I have described what I believe to be the best embodiment of my invention. I do not wish, however, to be confined to the embodiment shown, but what I desire to cover by Letters Patent is set forth in the appended claims.

I claim:

1. The method of producing a frequency modulated current from a source of fixed phase and frequency, which consists in varying the phase of a current derived from this source by an amount which is directly proportional to the amplitude of the modulating current and inversely proportional to the frequency of said current and multiplying the resultant phase shift a sufficient number of times to produce the required degree of modulation.

2. A transmitter for frequency modulated waves, comprising a source of current of fixed frequency and phase, a source of modulating current, and means for varying the phase of a current derived from this source by an amount which is directly proportional to the amplitude of the modulating current and inversely proportional to the frequency of said current and means for multiplying the resultant phase shift a sufficient number of times to produce the required degree of modulation.

3. A transmitter comprising a source of current

of constant frequency, a source of signaling current, and aperiodic means for deriving from said sources a current of variable frequency, the phase of which is shifted with reference to that of said first source directly proportionally to the amplitude of said second source and inversely proportionally to the frequency thereof, and means for multiplying the resultant phase shift a sufficient number of times to produce the required degree of modulation.

4. In a system of radio communication including a transmitter and a receiver, in which signaling is accomplished by frequency modulation of the transmitted waves, means at the transmitter operating aperiodically for creating a wave the frequency of which is modulated in accordance with the signals to be transmitted, means at the receiver operating aperiodically for translating the frequency modulations of the received wave into amplitude modulations, and means for detecting said amplitude modulations, to derive therefrom the transmitted signal.

5. A transmitter comprising a source of current of constant frequency, a source of signaling current, and aperiodic means for deriving from said sources a current of variable frequency, the phase of which is shifted with reference to that of said first source in accordance with variations in said second source, the angle of such shift being limited so as to maintain substantial proportionality between the angle of shift and the amplitude of signaling current, said aperiodic means having the characteristic of varying the phase of the said derived current directly proportionally to the amplitude of the modulating current and inversely proportionally to the frequency of said current.

EDWIN H. ARMSTRONG.

40

115

45

120

50

125

55

130

60

135

65

140

70

145

75

150