

agnecord

Instruction



Manual

MIDWESTERN INSTRUMENTS • MAGNECORD DIVISION
PO BOX 7509 • TULSA 35 • OKLAHOMA



FACTORY SERVICE

MIDWESTERN INSTRUMENTS, INC., maintains an instrument service department for repair and re-adjustment of all instruments returned to the factory. In the event the user feels that he has not received satisfactory operation from his equipment, he should immediately contact INSTRUMENT SERVICE DEPARTMENT, MIDWESTERN INSTRUMENTS, TULSA, OKLAHOMA. Be sure to include model number, serial number, a complete outline of the malfunction symptoms and a description of the use of the equipment. Such information often enables us to make suggestions which will avoid returning the equipment to our plant.

When it is necessary to return equipment to the plant, it should be carefully packed and shipped via prepaid express or equivalent, and properly identified by a packing slip or suitable tag or both.

FACTORY WARRANTY

Magnecord products are guaranteed to be free of defects in materials and workmanship for a period of 90 days from date of sale to initial user. Midwestern will replace or repair any parts found defective during the warranty period subject to factory inspection and approval. Warranty is void unless warranty cards are fully executed and mailed to the factory within ten days of purchase.

Copyright 1962 by
MIDWESTERN INSTRUMENTS, INC.

P. O. Box 7509
Tulsa, Oklahoma

All rights reserved. This manual, or parts thereof, may not be reproduced in any form without permission of MIDWESTERN INSTRUMENTS, INC.

TABLE OF CONTENTS

	<i>Page No.</i>		<i>Page No.</i>
SECTION I — GENERAL DESCRIPTION		Rewind System	4
Specifications — PT6-6A Tape Transport	1	Drive System	4
Specifications — PT6-6J Amplifier	1	Tape-Up System	4
SECTION II — OPERATING INSTRUCTIONS		SECTION III—ADJUSTMENTS AND MAINTENANCE	
Threading the Tape	3	Solenoid Adjustments	9
Recording Operation	3	Clutch Adjustments	9
Rewind Procedure	3	Cleaning	10
Tape Playback	4	The Clutch Felts	10
Hi-Speed Forward Control	4	Bias Control Adjustment	12
Recording Indicator	4	50-Cycle Operation	12A
Flywheel and Capstan	4	PARTS LIST	
Pressure Roller	4	Mechanical Parts List	13
Hi-Speed Forward Operation	4	Bias Oscillator	14
		Amplifier	14

LIST OF ILLUSTRATIONS

<i>Figure No.</i>	<i>Title</i>	<i>Page No.</i>	<i>Figure No.</i>	<i>Title</i>	<i>Page No.</i>
1	Rear View of Tape Transport	2	8	Top View of Bias Oscillator Chassis	8
2	Right Side View of Tape Transport	2	9	Bottom View of Bias Oscillator Chassis	10
3	Bottom View of Tape Transport	5	10	Bottom View of PT6-6J Amplifier Chassis ...	11
4	Tape Transport, Front Panel Removed	5	11	Bottom View of PT6-6J Amplifier Chassis ...	11
5	Exploded View, Parts above Front Panel ...	6	12	Top View of PT6-6J Amplifier Chassis	12
6	Exploded View, Parts below Front Panel...	7	Sch.	Tape Transport PT6-6A	16
7	Exploded View, Parts below Back Panel ...	8	Sch.	Amplifier Models PT6-J, PT6-6J	17

SECTION I

GENERAL DESCRIPTION

The Magnecord Model PT6-6A Tape Recorder features STOP, FORWARD, FAST FORWARD, and REWIND modes of operation. PLAYBACK or RECORD is selected by a switch on the amplifier. The transport is designed to utilize 7-inch reels. New recordings can be made on previously recorded tape, since the erase head is automatically connected when the amplifier switch is in the RECORD position.

The tape speed switch located on the front panel will select 15 ips, 7½ ips, or 3¾ ips, depending on the size of the capstan and pressure roller being used. The combination of the large capstan and the small pressure roller produces 15 ips in the SLOW position. The small capstan and large pressure roller combination obtains 7½ ips in the FAST position and 3¾ ips in the SLOW position.

The Magnecord Model PT6-6A Tape Recorder is designed for use with the Model PT6-6J Amplifier. The unit is intended to be used on a power source of 117 volts, 60-cycle current. Power for the tape transport is furnished through the amplifier. This includes 117V 60-cycle for the motor, 6.3V 60-cycle for the oscillator heater, and 300-volt direct current for the oscillator plate circuit.

SPECIFICATIONS — PT6-6A TAPE TRANSPORT

TAPE SPEEDS: 3¾ ips, 7½ ips, and 15 ips are interchangeable with no tools required. The tape speed selection is made by switch and/or change of capstan and pressure roller.

REWIND SPEED: 1,200 feet rewound in 40 seconds.

FLUTTER: Less than 0.3%.

TUBE: Bias oscillator tube 12AU7.

MOTORS: 1,500 RPM rewind motor. Hysteresis synchronous two-speed, 900 RPM and 1,800 RPM drive motor.

FREQUENCY RESPONSE: 50 to 7,500 cps with tape speed of 7½ ips; 40 to 15,000 cps at tape speed

of 15 ips.

SPECIFICATIONS — PT6-6J AMPLIFIER

FREQUENCY RESPONSE: 50 to 15 KC, ±2 db equalized for tape speeds of 7½ and 15 ips. A 3¾ and a 7½ ips equalizer is available.

INPUT LEVEL SENSITIVITY: 105 dbm for zero level recording.

MAXIMUM LEVEL: 35 dbm.

INPUT IMPEDANCE: 50 or 250 ohms, balanced or unbalanced. High impedance unbalanced bridge (phone jack).

NOISE: 50 millivolts maximum at 600-ohm output (switch at AMP); 20 millivolts maximum at 600-ohm output (switch at PLAYBACK). Rec-PB overall signal-to-noise ratio 50 db from 3% third harmonic distortion point.

TOTAL HARMONIC DISTORTION: Less than 2% with 10 watts output.

OUTPUT IMPEDANCE: 600 ohms balanced, 16 and 4 ohms.

OUTPUT: 10 watts with less than 2% distortion.

TUBES: (1) Type 5879
(1) Type 12SJ7
(1) Type 6SL7
(2) Type 5881
(1) Type 593

DIMENSIONS: Amplifier — 8" deep, 7" high, 19" wide without carrying case. Transport Mechanism — 11" deep, 7" high, 19" wide without carrying case and 16" deep, 8" high, 20" wide including carrying case.

INSTALLATION: These units may be mounted in portable cases or standard 19-inch racks without adapter panels.

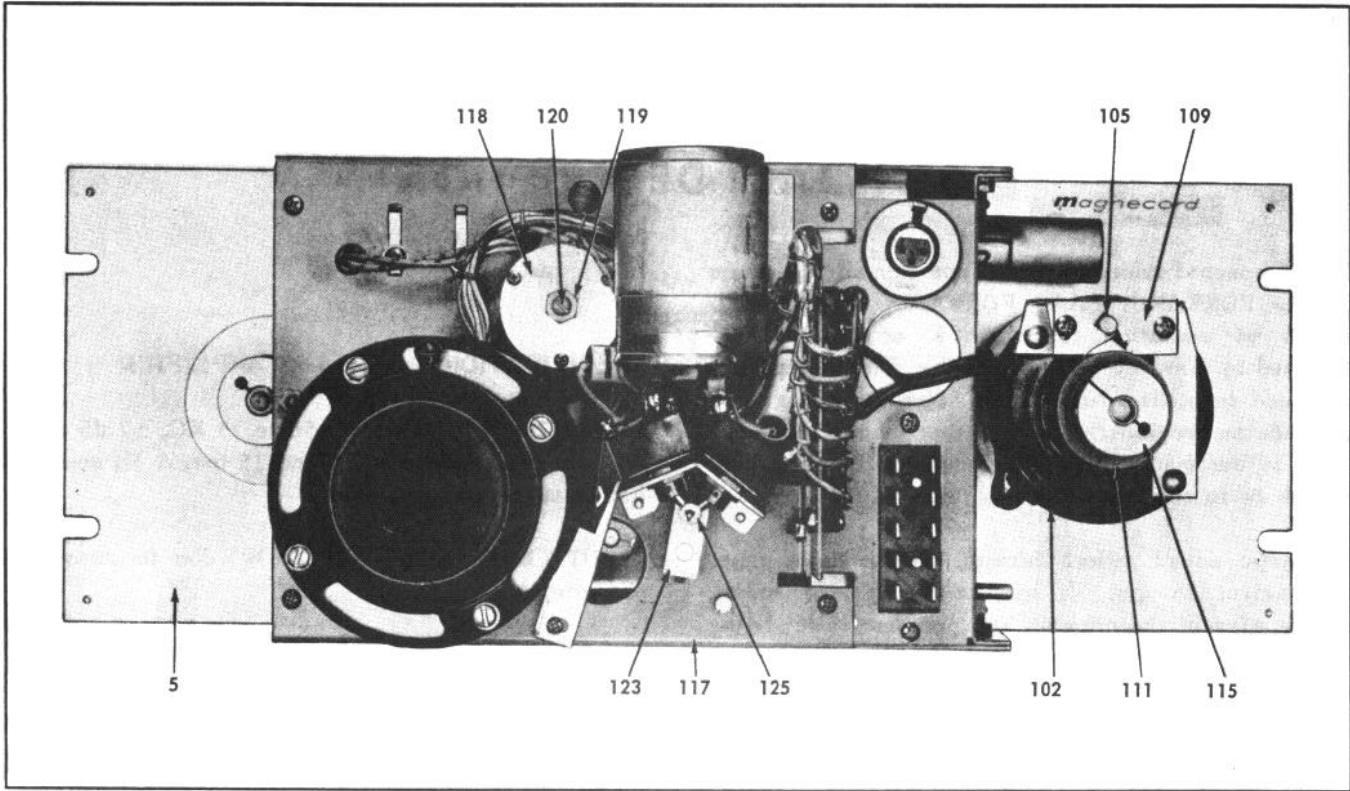

Figure 1. Rear View of Tape Transport.

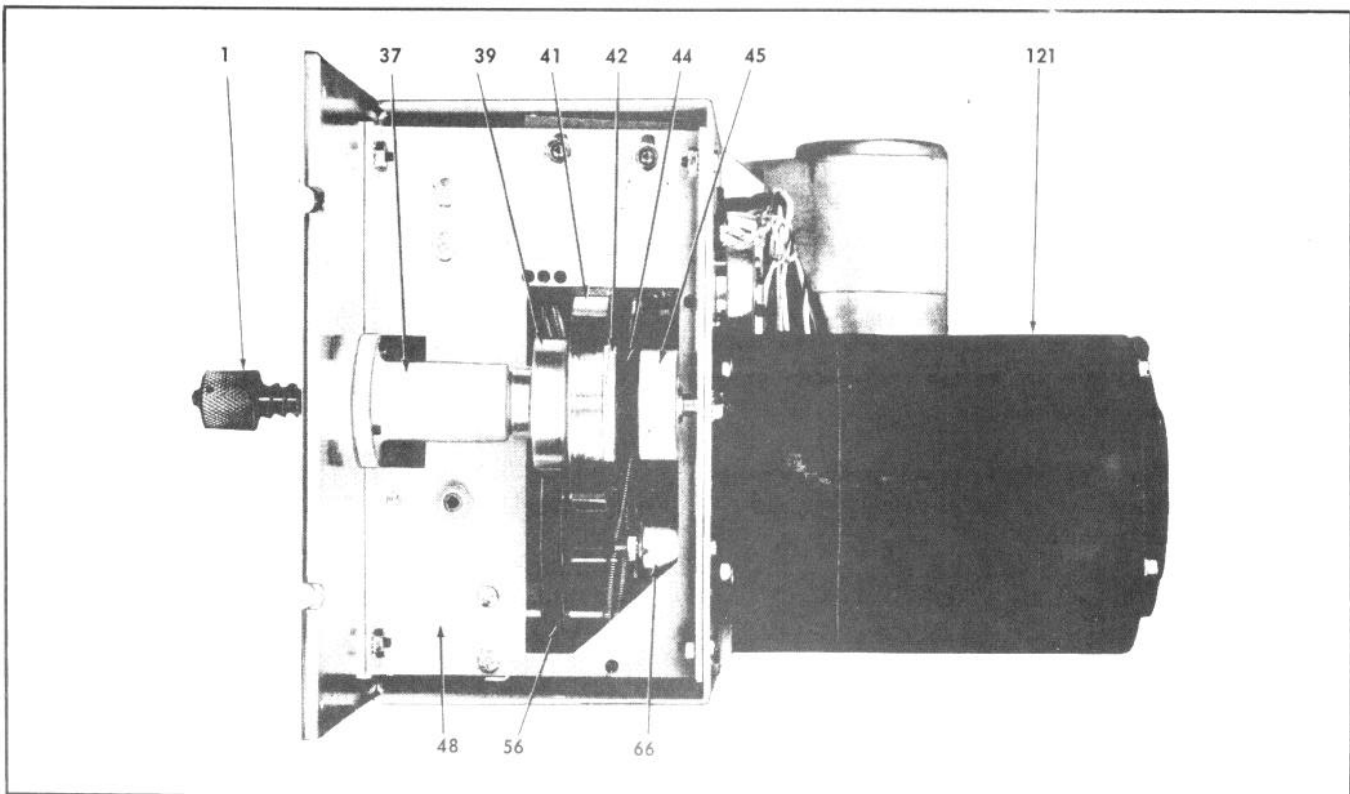

Figure 2. Right Side View of Tape Transport.

SECTION II

OPERATING INSTRUCTIONS

The PT6-6A motors and oscillator tube receive their power through a male Jones connector on the rear of the unit. See schematic for terminal designation. This power is supplied by the PT6-6J amplifier. The female Cannon connector on the rear of the PT6-6A is connected to the male Cannon connector on the rear of the PT6-6J amplifier by an interconnecting cable. This cable couples the record/reproduce head of the transport mechanism to the playback amplifier input in the PLAYBACK mode, and couples the output of the record amplifier to the record/reproduce head in the RECORD mode.

The correct capstan and pressure roller for the desired speed and the knurled retaining screws should be firmly in place during operation. For speed and speed changes, see Section I. Make sure the taper-shaped capstan shaft is completely free from dirt or foreign particles before installing the capstan. Make sure the oscillator tube located in rear and at right side is secure in its socket.

THREADING THE TAPE

1. To remove the reel knobs, push in and turn counter-clockwise to release the bayonet pin.
2. Place an empty reel on the take-up spindle (36) and replace the reel retaining knob (1).
3. Place a reel of tape on the rewind spindle (2), with the tape paying off in a clockwise direction, and replace the reel retaining knob (1).
4. Pull off about 2 feet of tape, thread over and around the top tape guide roller (23), then around the lower tape guide roller (9), over the erase head (15) and record/playback head (29), between the capstan (33) and pressure roller (35); then thread onto the empty take-up reel. Make sure the oxide coating on the tape is toward the heads.

RECORDING OPERATION

1. Flip the power switch on the amplifier to ON. This provides necessary power for both amplifier and recorder mechanism.

2. Turn the amplifier selector switch to the RECORD position.

3. Push the VU meter switch in to connect the meter, if the PT6-6J amplifier is used with the PT6-6A tape transport mechanism.

4. For headphone monitoring, insert the phone plug into the amplifier front panel MONITOR jack. For speaker monitoring, turn the speaker VOLUME control up to the desired position.

5. Vary the volume level with the gain control. Turning the control clockwise increases the amplifier gain. The VU meter should move with the program material and should read a peak value of 0 once every few seconds to a minute, depending upon the nature of the program being recorded.

6. To place the tape transport mechanism in RECORD position, depress the safety button (19) and simultaneously turn the control knob (30) to FORWARD. This sets the tape in motion.

7. The red bias indicator will glow when the oscillator is operating properly. This indicates a new recording is being made and previous recording on the tape will be erased.

8. When the recording is completed, turn the control knob (30) to STOP.

REWIND PROCEDURE

1. To rewind tape, turn the control knob (30) to STOP, then place the tape over the guide roller (23) from reel to reel. Turn the control knob to REWIND. The rewind mechanism, driven by a shaded-pole motor (102), will completely rewind 1200 feet of tape (full 7-inch reel) in approximately 40 seconds.

2. The control knob (30) may be turned to STOP any time during rewind without danger of tape spilling.

3. To rewind the tape without unthreading, the tape should be placed on top of the record/reproduce head shield. Be sure the tape is returned to its normal position on the heads before recording or reproducing.

CAUTION

When switching from REWIND to FORWARD,

always pause in STOP position long enough for the tape to come to a complete stop. Failure to do so will result in tape breakage due to the tight grip which the capstan and pressure roller exert on the tape when the control knob (30) is in FORWARD position.

TAPE PLAYBACK

1. Make interconnections and correct speed as described under Operating Instructions.
2. Set the selector switch on the amplifier (PT6-6J) to PLAYBACK position.
3. Turn the speaker VOLUME control clockwise; pull the meter switch out for OFF if the volume level on playback makes it necessary to prevent meter damage.
4. Depress the safety button (19) and place the control knob (30) in FORWARD position.

HI-SPEED FORWARD CONTROL

The hi-speed forward control is located on the right side of the front panel. This control will function only with the main control knob in STOP position. To place the machine in HI-SPEED FORWARD, turn the control to the right and hold. To stop the machine, release the control.

If you have rewound tape too far, turn the hi-speed forward knob to reel tape rapidly forward until the beginning of the recording is reached.

RECORDING INDICATOR

The recording indicator lamp will glow when plate supply voltage is supplied to the oscillator tube. This indicates any previous recording on the tape is being erased and a new recording may be made.

FLYWHEEL AND CAPSTAN

A balanced flywheel with drive hub and capstan shaft assembly (83), driven by two rubber-surface wheels (67, 70), provide constant speed for tape travel.

PRESSURE ROLLER

The pressure roller (35) is actuated by the control knob (30), control shaft (93), and pressure roller arm assembly (79). The tension spring keeps a positive pressure against the tape and capstan, maintaining a constant rate of tape travel.

HI-SPEED FORWARD OPERATION

The HI-SPEED FORWARD mode is actuated by rotating the hi-speed forward control knob (17A) in a clockwise direction. This, in turn, actuates the control shaft and wire (126), the pivot arm (53),

wire (52), and fast forward wheel mounting bracket (50), pulling the fast forward wheel (56) into contact with the drive motor shaft and take-up hub (39). Simultaneously, the pivot arm (53) moves against the fast forward actuating switch, starting the main drive motor (121).

REWIND SYSTEM

When the control knob (30) is placed in REWIND, a switch (125) is actuated, starting the rewind motor (102). A DC operated solenoid is also energized during rewind, pulling the forward idler wheel (61) away from the take-up hub (41), allowing the bearing mounted take-up shaft (36) to turn freely. When rewind operation is completed and the control knob (30) returns to STOP position, the solenoid is de-energized. This allows the forward idler wheel (61) to contact the take-up hub (41), applying a braking force sufficient to stop the reel.

The one-way, pawl-actuated clutch on the rear shaft extension of the rewind motor (102) operates so that, as the tape is unwound from the payoff spindle (2), a certain amount of drag is imparted to the motor shaft, which is then transmitted to the tape as tension. When rewinding, the pawl is disengaged from the ratchet disc (111) by a direction sensitive rewind pawl spring (110), allowing the motor shaft to turn freely. A rapid rewind results.

DRIVE SYSTEM

The drive system consists of a main drive motor (121) and two rubber-surface idler wheels (67, 70), mounted on sliding suspension arm supports (85, 87). The idler wheels (67, 70) are held in contact with the hub of the flywheel assembly (83) and drive motor shaft (121) by springs (71). This, in turn, drives the capstan (33) which is secured to the flywheel shaft and, with the pressure roller (35), conveys tape at a constant speed.

TAKE-UP SYSTEM

The take-up shaft (36) is driven by a forward idler wheel (61) making contact with the drive motor shaft and take-up hub (41). The take-up hub (41) is concentrically mounted on the take-up shaft (36) and is coupled to the shaft through a clutch assembly (39 through 46) similar to that in the rewind system. With the tape properly threaded on the recorder and the mechanism in FORWARD, the take-up shaft (36) slips a certain amount due to pressure applied on the tape by the slower running capstan and pressure roller. Consequently, tension imparted to the tape causes it to move from one reel to the other without throwing or stalling.

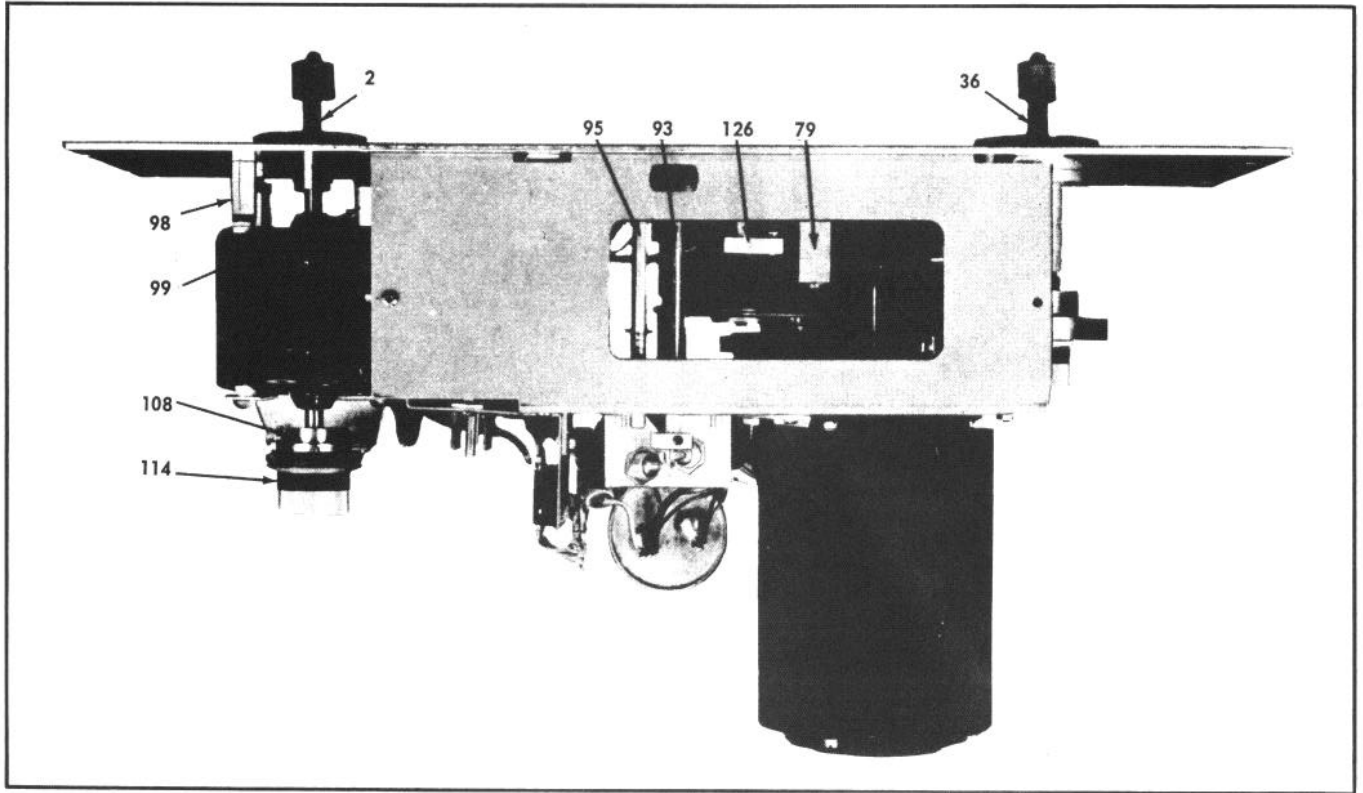

Figure 3. Bottom View of Tape Transport.

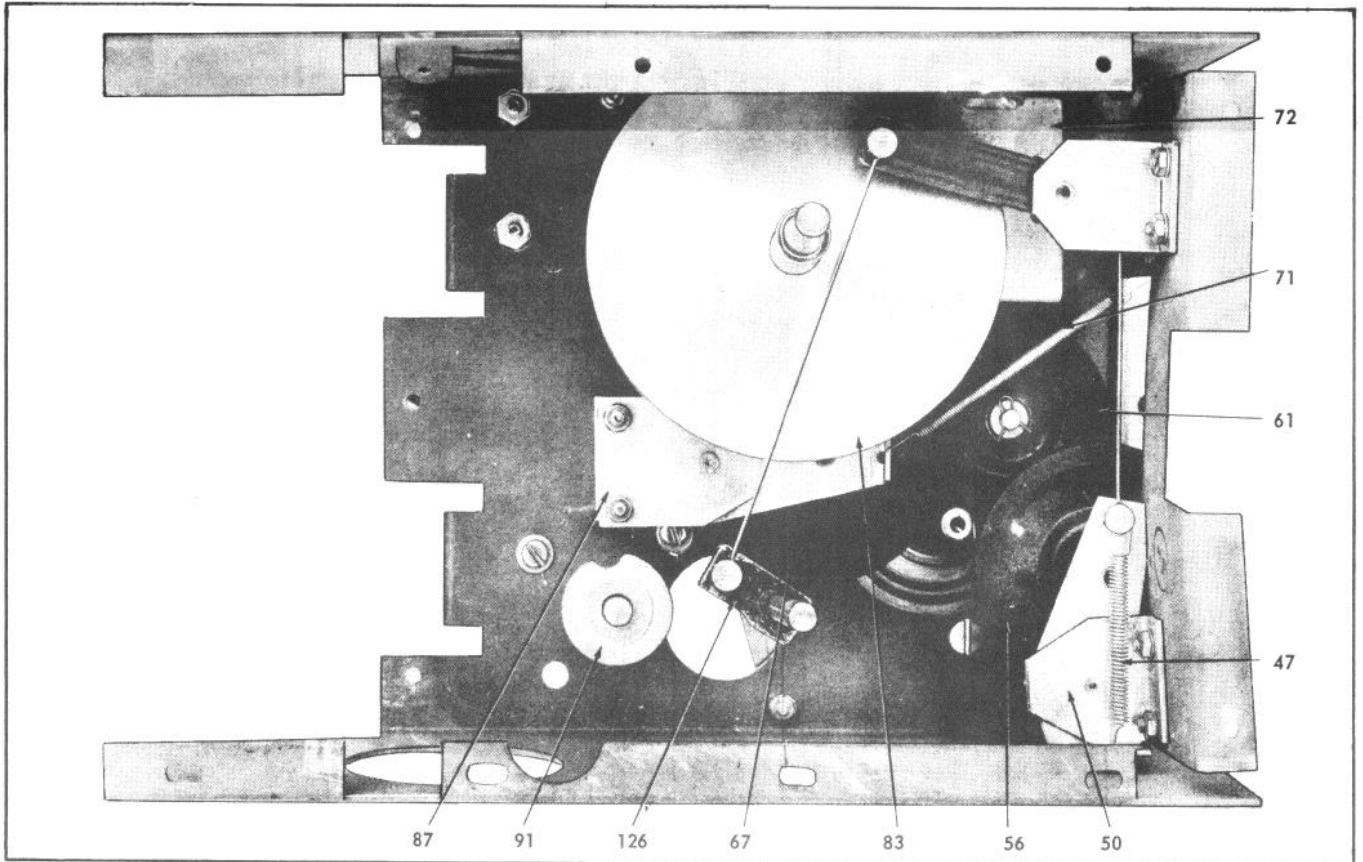

Figure 4. Tape Transport with Front Panel Removed.

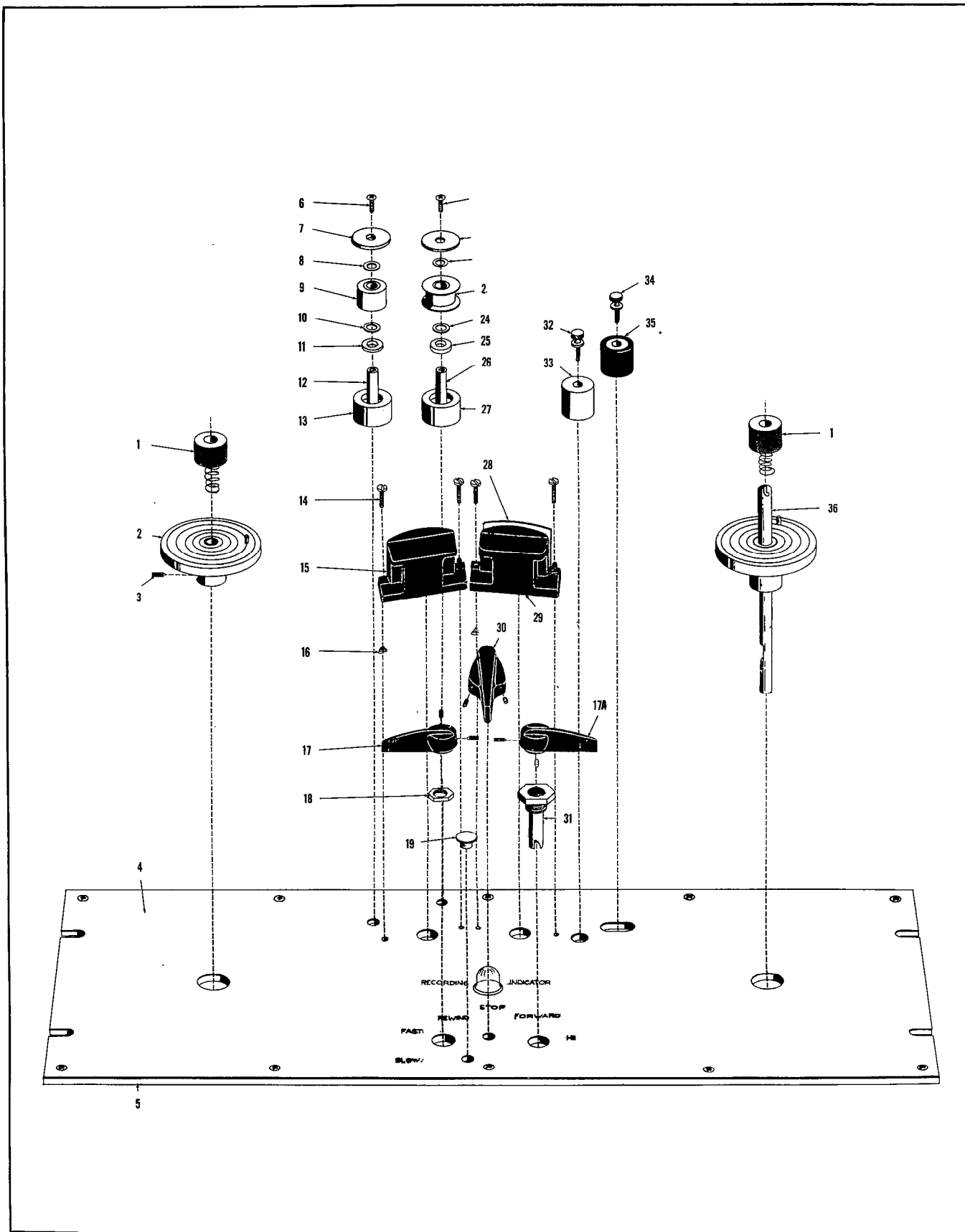

Figure 5. Exploded View of Parts Above Front Panel.

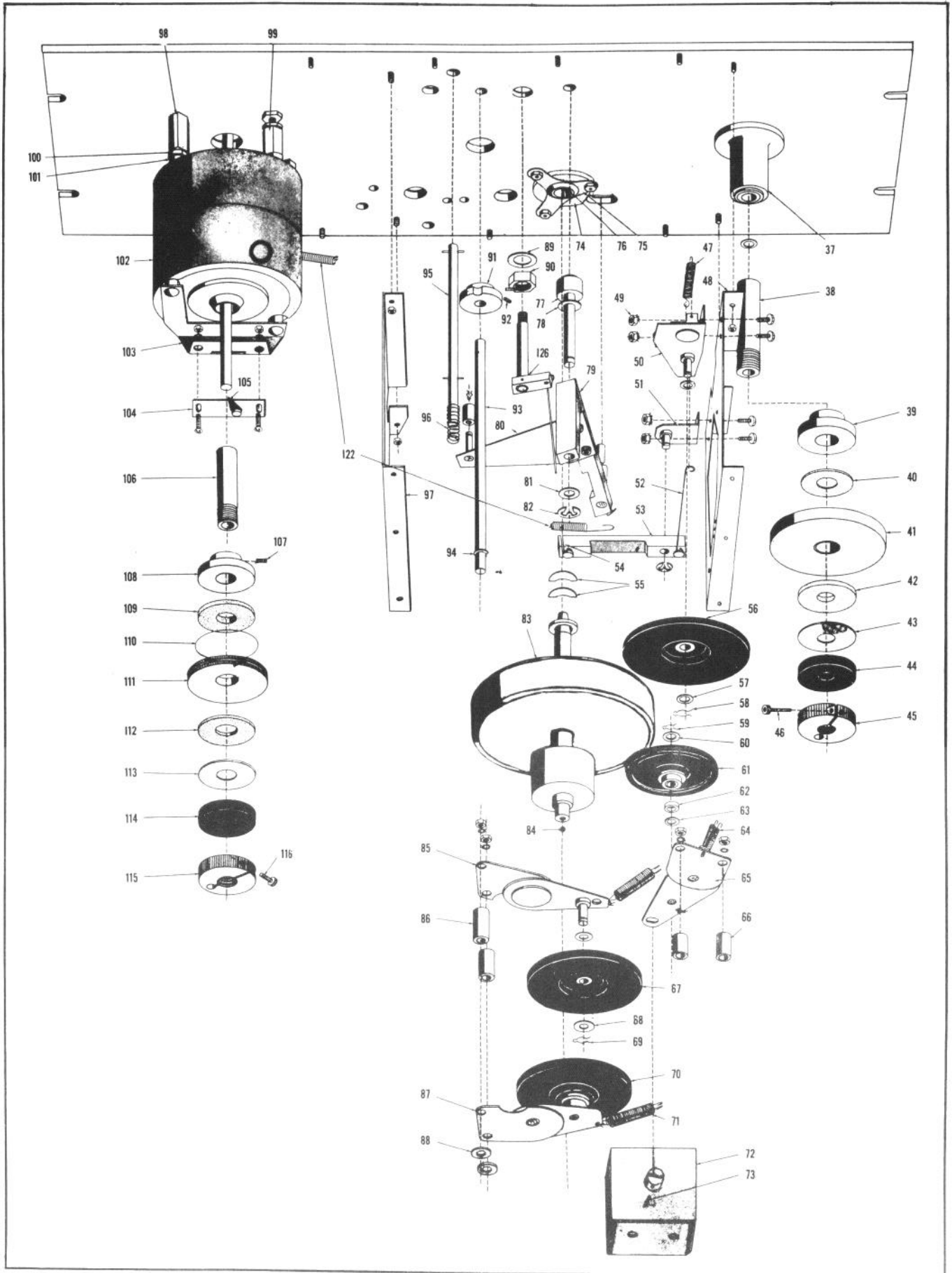

Figure 6. Exploded View of Parts Below Front Panel.

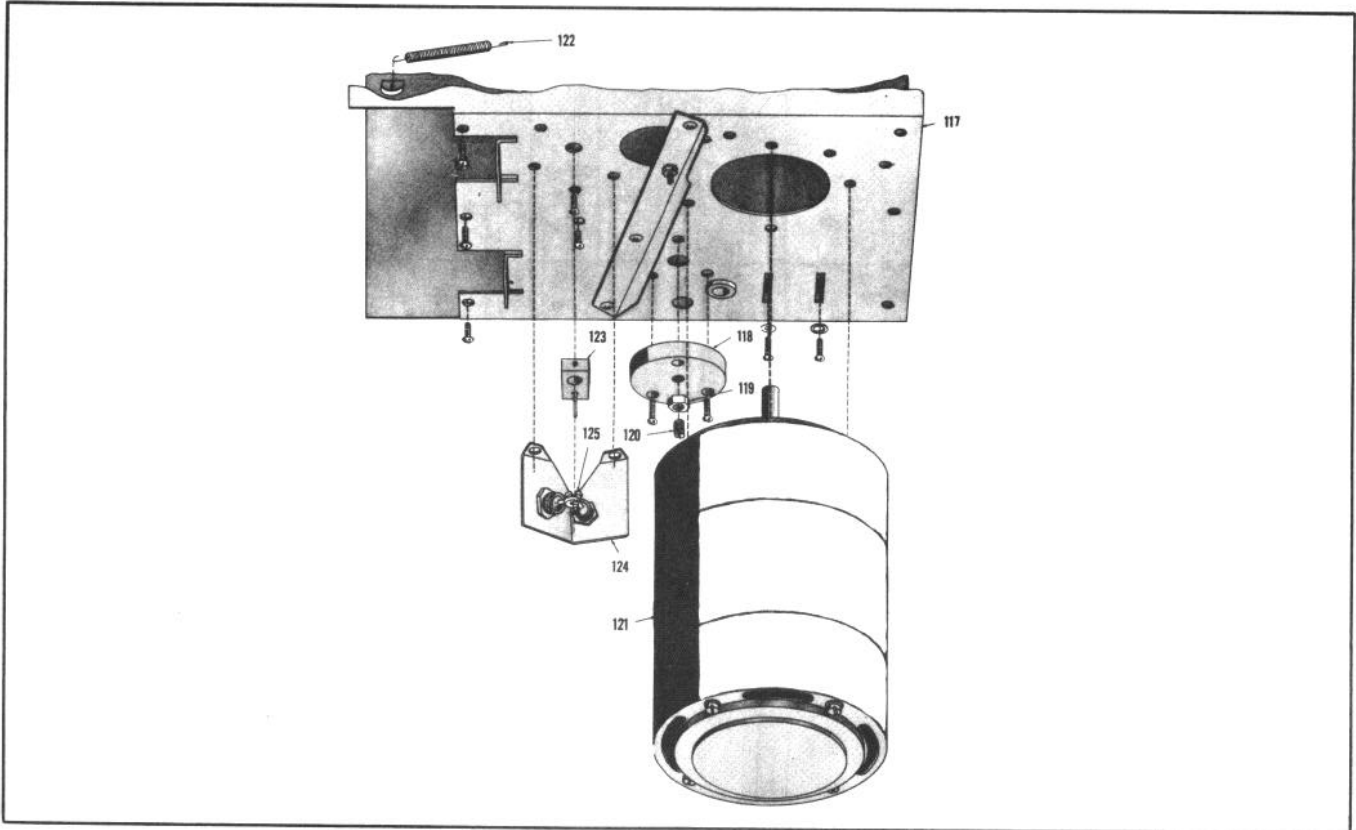

Figure 7. Exploded View of Parts Below Rear Panel.

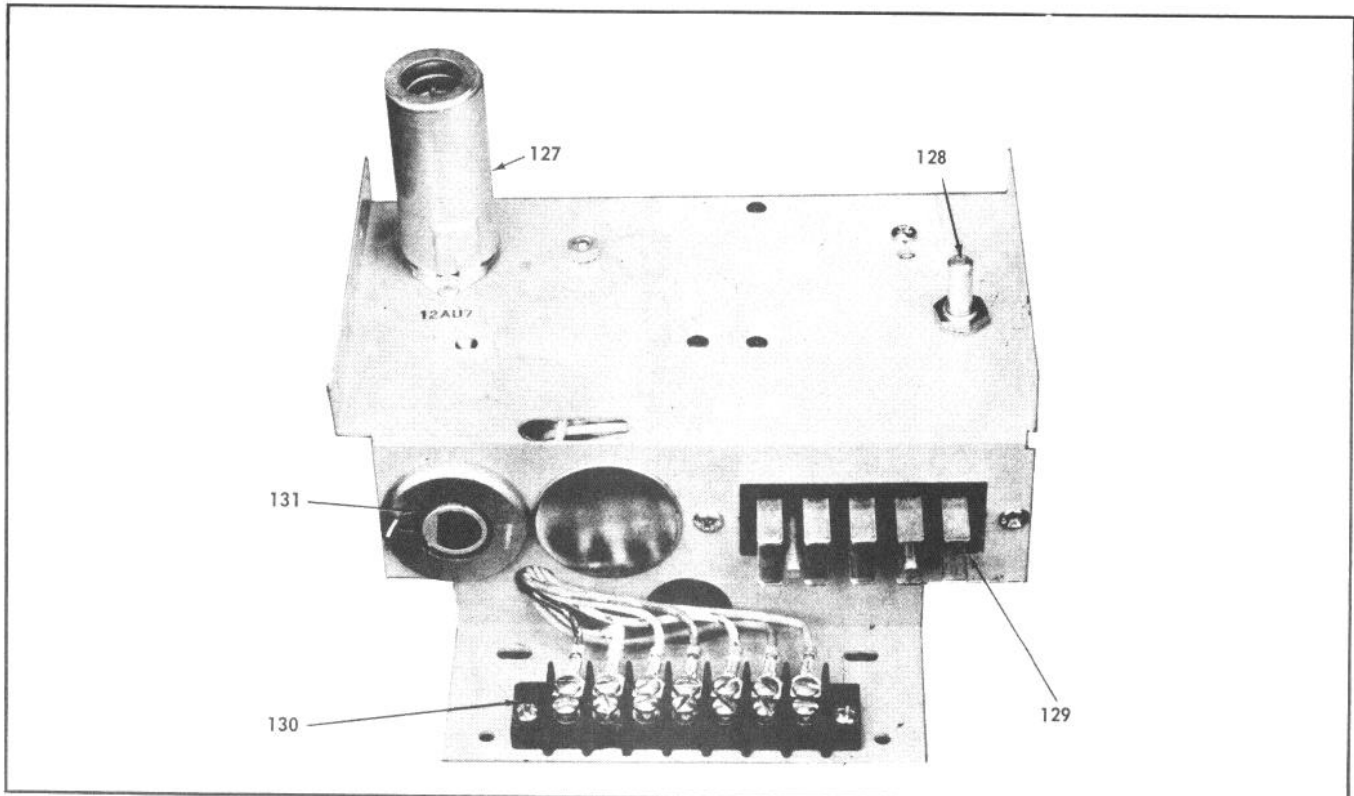

Figure 8. Top View of Bias Oscillator Chassis.

SECTION III

ADJUSTMENTS AND MAINTENANCE

NOTE

Before attempting to align the record/reproduce head, make certain difficulty is not due to an accumulation of tape coating residue on the pole surfaces.

1. The primary purpose of head alignment is to provide maximum frequency response.
2. The right side mounting screw of the record/reproduce head is drawn up securely. This side of the head holder is provided with a rocker action. The left side adjustment screw (14) is associated with a compression spring. Rotating this screw changes gap alignment with respect to the tape. Proper alignment is achieved when maximum signal, at a given setting of the gain control, is reproduced from the alignment tape, as the alignment screw (14) is turned in or out.

SOLENOID ADJUSTMENTS

The plunger of the solenoid (72), energized during rewind, should pull against the springs (64) and lift the idler wheel (61) away from the drive motor shaft by 1/16 inch, but maintain contact between the idler wheel (61) and the take-up wheel (41). When the mechanism is switched from REWIND to STOP, the solenoid relaxes, and the springs (64) return the idler wheel (61) into contact with the drive motor shaft. This shaft is not turning and, in turn, the idler wheel (61) is prevented from turning. This stops free rotation of the take-up wheel (41), acting as a brake on the take-up shaft.

The solenoid (72) should be positioned to accomplish the above. The solenoid is mounted by two screws in slotted holes in the back panel above the drive motor (121). When readjusting the solenoid, be careful the plunger does not bind within the tube. To check this, place the recorder in its operating position and operate the control knob (with power applied to the mechanism) between REWIND and STOP. The return springs (64) should have enough tension to return the idler wheel (61) to normal position when there is no binding of the solenoid plunger.

CLUTCH ADJUSTMENTS

Tape tension is maintained by two friction clutches. Their correct adjustment causes the tape to move from one reel to the other in either direction without throwing tape or stalling, and applies proper tape tension for tape contact on the heads.

1. The clutches are located on the rear ends of the supply reel spindle (2) and the take-up reel spindle (36). The supply reel spindle clutch is located at the right side (facing rear of unit). It consists of a felt washer (112) lubricated with silicone fluid pressing against a ratchet (111), free to rotate in a clockwise direction, but prevented from turning in the opposite direction by a spring-loaded pawl (105). Pressing against the opposite side of the felt washer is a brass washer (113) and a sponge rubber washer (114). On the other side of the ratchet (111) is a silicone lubricated felt washer (109) which also exhibits a clutch effect. To remove the complete friction assembly, loosen the screws (107, 116) and slide the assembly off the shaft. A split knurled adjustment locknut (115) bears against the sponge rubber washer (114) and is loaded in place by a set screw (116). The set screw must be backed off before the adjusting locknut (115) can be turned. Rotating the adjustment locknut clockwise increases clutch friction.

2. The supply reel spindle clutch adjustment should maintain a drag as the supply reel rotates when the recorder is in FORWARD operation. This drag should be sufficient to stop the supply reel without permitting tape to loop, or to be thrown when the control knob switch is turned from FORWARD to STOP. The amount of friction should be the minimum necessary to accomplish this (3 to 4 inch-ounces).

3. Too much clutch friction will increase tape drag to a point where tape speed will cause flutter and wow.

4. The take-up reel (36) friction clutch is located on the left side (facing the rear). This is similar in appearance to the other clutch but employs no pawl. It is also necessary to back off the set screw (46) before adjusting this clutch.

5. The take-up reel spindle friction clutch couples the spindle to the synchronous drive motor when the control is set to FORWARD, and acts as a brake on the take-up reel when the control knob is set to STOP. Clutch adjustment should provide sufficient friction for the take-up reel to take up tape at normal speed forward when the take-up reel is almost completely full and the supply reel nearly empty. It should also provide sufficient braking to maintain tape tension and prohibit tape throwing when the control switch is turned to STOP, after the take-up reel has been rotating at a high speed during rewind. The split knurled locknut (45) should be adjusted to provide minimum clutch friction to accomplish this. About 4 to 6 inch-ounces for the take-up clutch is correct friction.

CLEANING

Portions of the erase and the record/reproduce heads which contact the tape must be kept free of dust, grease and foreign matter, or frequency response characteristics will suffer. Clean with a soft, lintless cloth slightly moistened with carbon tetrachloride

or ethyl alcohol after every five hours of operation.

NOTE

Do not attempt to apply carbon tetrachloride to any part of the recorder when loaded reels are in place. Tape is soluble in carbon tetrachloride and will be ruined if it comes in contact with the solution. After using carbon tetrachloride, make sure that the heads are completely dry before threading tape and that none of the solution is transferred to the tape from the fingers.

OILING THE CLUTCH FELTS

The felt washers have been lubricated with silicone fluid at the factory to provide correct amount of slippage.

CAUTION

Do not oil the clutch felts. This may cause oil to be thrown on nearby idlers, causing slippage in the drive system.

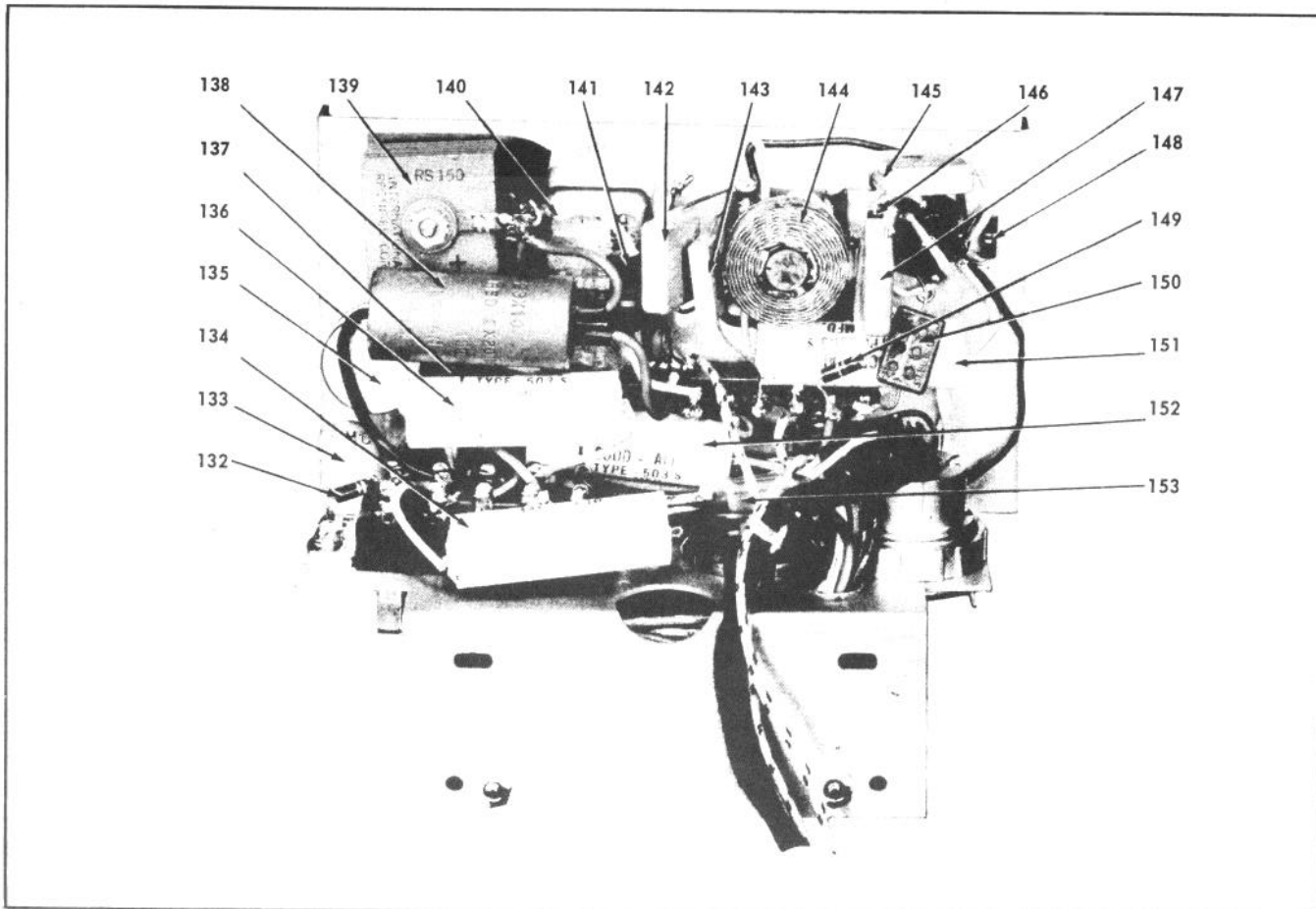

Figure 9. Bottom View of Bias Oscillator Chassis.

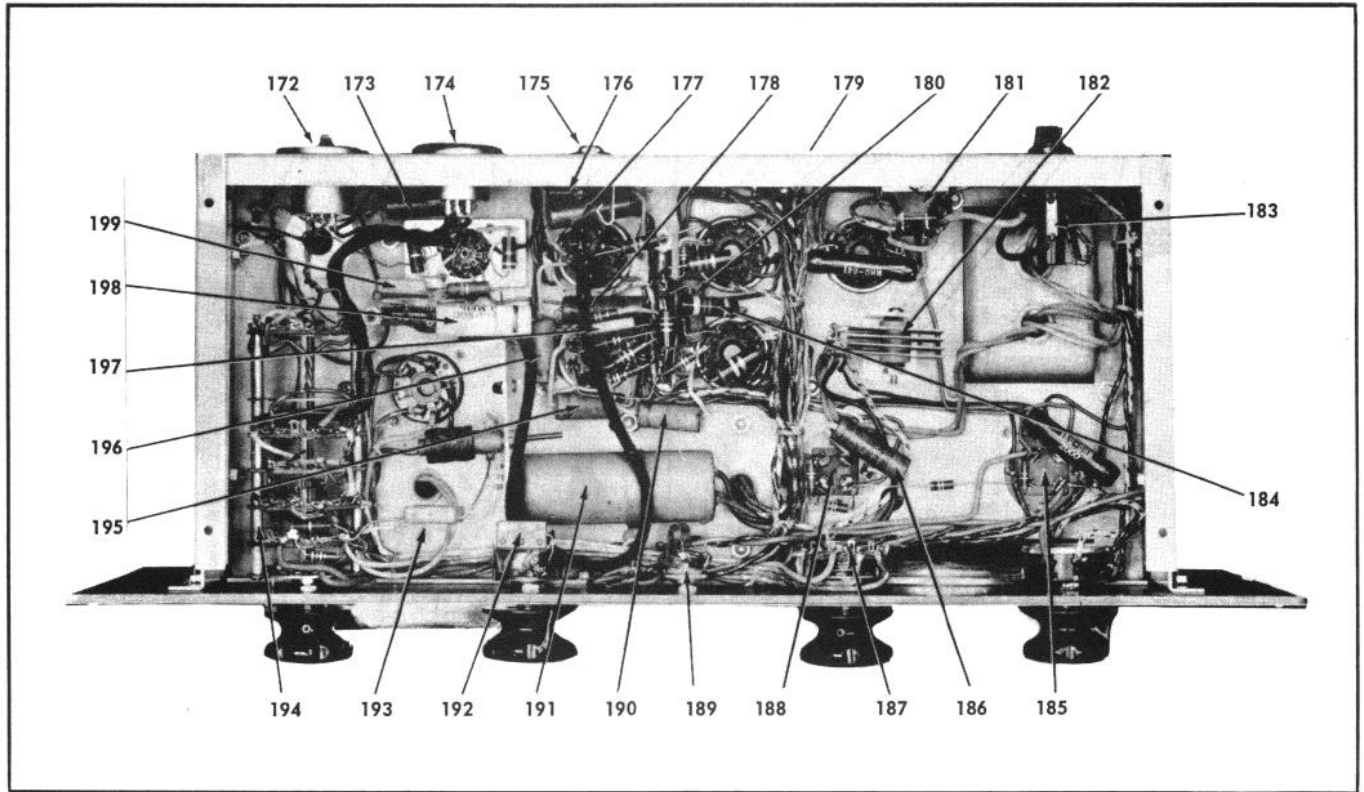

Figure 10. Bottom View of PT6-6J Amplifier Chassis.

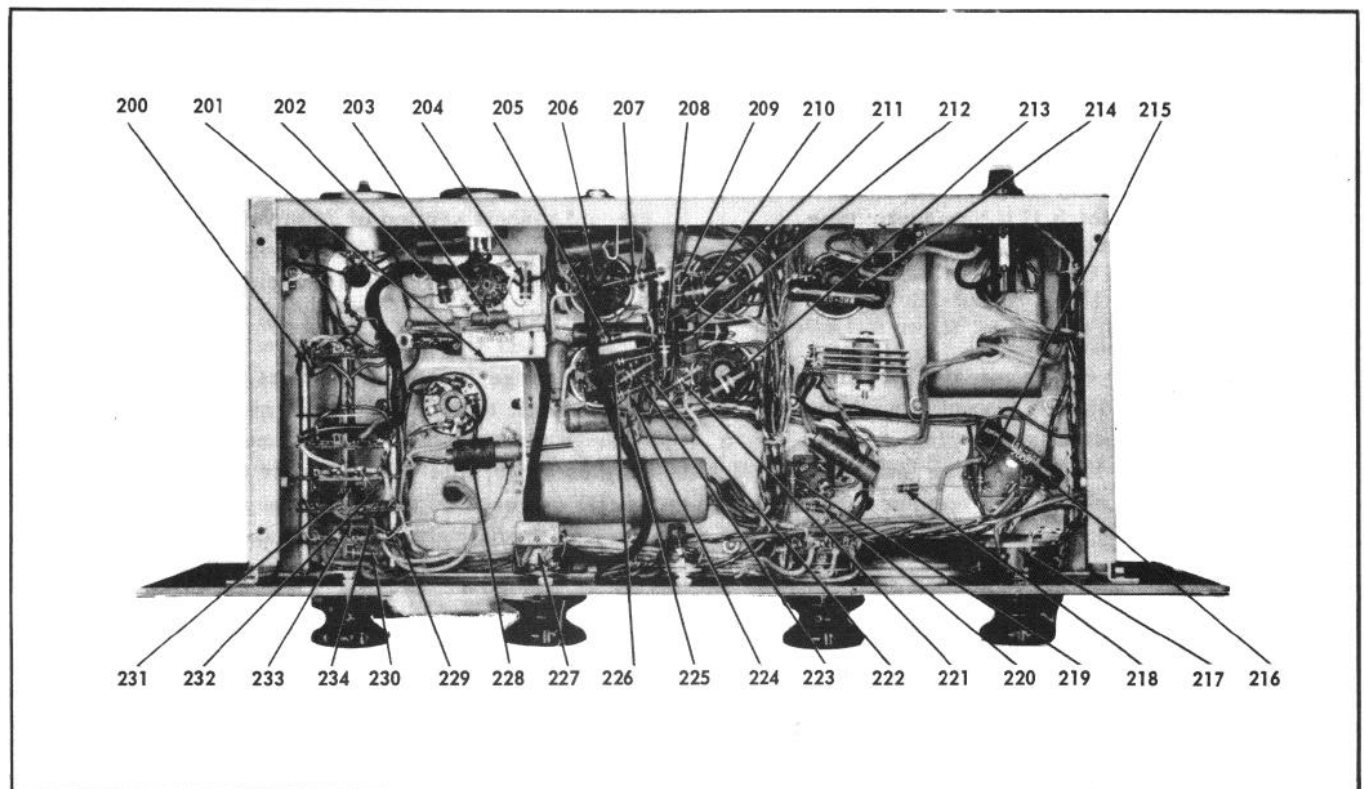

Figure 11. Bottom View of PT6-6J Amplifier Chassis.

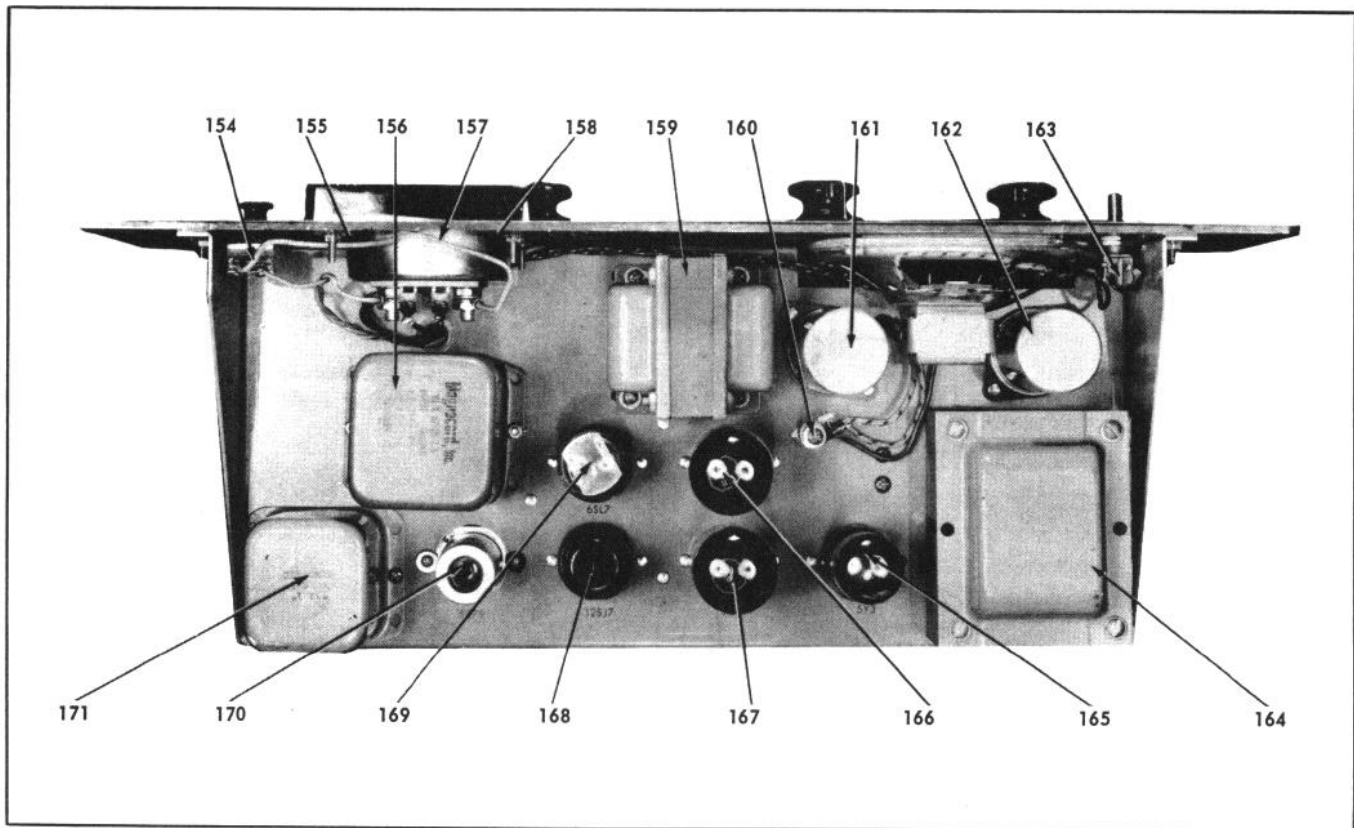

Figure 12. Top View of PT6-6J Amplifier Chassis.

BIAS CONTROL ADJUSTMENT

A. REQUIRED EQUIPMENT:

1. Audio oscillator, Hewlett Packard 200CD or equivalent.
2. A.C.V.T.V.M. Ballantine 300 or equivalent.
3. 16-ohm, 10-watt resistor.
4. One reel of Scotch 111-A magnetic tape.
5. Test cable, 2-conductor, with phone plug on one end.

B. SET-UP PROCEDURE:

1. Connect the output of the oscillator to the BRIDGE input on the PT6 amplifier, using the test cable with the attached phone plug.
2. Connect the 16-ohm resistor and the VTVM in parallel with the 0 and 16-ohm terminals on the rear of the amplifier.

NOTE

Be sure to observe proper ground connections in the proceeding set up.

C. REFERENCE LEVEL ADJUSTMENT:

1. Set the amplifier function switch to RECORD, the

VU meter switch to ON, the oscillator frequency to 200 cps, and the amplifier volume control to about 50% rotation.

2. Advance the level control on the oscillator until the VU meter on the amplifier reads 0 VU.
3. Set the transport's bias control to 50% rotation.
4. Load the transport with the reel of tape and record a short section of 200 cycles at 0 VU.
5. Rewind to the beginning of the recorded portion, set the amplifier function switch to LISTEN, and play the 200-cycle tone.

6. Adjust the gain control for a convenient reading in the range from 1 to 50 volts on the VTVM (use a level such that if the output of the amplifier should change plus or minus 6 db, the meter will still be reading on scale; this will eliminate the need of switching meter ranges if output level changes). This is your reference level. Make a note of the level and DO NOT disturb the setting of the gain control for the remainder of the tests.

7. Set the amplifier function switch to RECORD. Adjust the oscillator level control until the VU meter reads 0 VU. DO NOT disturb the oscillator setting for the remainder of the tests.

D. BIAS LEVEL ADJUSTMENT — COARSE:

1. Record 200 cps at 0 VU. Play it back and note

output level.

2. Rotate the bias control about 30 degrees and repeat step D-1. The object is to set the bias level so that maximum output is obtained from the tape. Alternately record a short segment of tape and reset the bias control until the maximum output level is obtained.

E. BIAS LEVEL ADJUSTMENT — FINAL

1. Adjust the output of the oscillator until the VU meter reads minus 10 VU.

2. Make a recording of a 1KC tone about 1 minute long.

3. While recording at the $7\frac{1}{2}$ ips speed, sweep the oscillator from 50 cps to 7.5 KC.

4. Play this recording back. The output level from the tape should not vary by more than 4 db from the highest reading to the lowest reading. If the high frequency portion of this tape is out of this tolerance, it may be adjusted by means of the bias control. If the high frequencies are too high in amplitude, increasing the bias will reduce the high frequencies.

To increase the high frequencies, the bias should be reduced.

NOTE

The proper bias setting will usually be one that is a compromise between maximum 200 cps output and flat frequency response.

50-CYCLE OPERATION

For 50-cycle operation the correct capstan and pressure roller must be used. When tape speeds of $7\frac{1}{2}$ ips (SLOW) and 15 ips (FAST) are required, the large capstan P/N 75A21 and small pressure roller P/N 91A20 are used. For $3\frac{3}{4}$ ips (SLOW) and $7\frac{1}{2}$ ips (FAST) operation, the small capstan P/N 75A22 and the large pressure roller P/N 91A19 must be used.

The necessary parts for 50-cycle operation are available from the Magnecord parts department.

MECHANICAL PARTS LIST

ITEM NO.	PART NO.	DESCRIPTION	ITEM NO.	PART NO.	DESCRIPTION
1	A91A5-1	Reel Retainer (2)	56	A91A86-1	Fast Forward Puck 2½"
2	A91A82-1	Rewind Reel Flange Assembly	57	A63A19-1	Washer
3	A61X368-1	8x32x3/16 Allen Head Set Screw	58	A67A12-1	Hairpin Retainer
4	A71D772-1	Matte Panel	59	A67A12-1	Hairpin Retainer
5	A71D771-1	Front Panel	60	A63A19-1	Fibre Washer
6	A61X111-1	#4-40x5/16 Phillips B.H.M.S. St. N.P.	61	A91A740-1	Take-up Puck Assembly 2"
7	A63A5-1	Dural Washer	62	A63X16-1	Felt Washer
8	A63A28-1	Fibre Washer	63	A63A19-1	Fibre Washer
9	A91A49-1	Roller & Bearing Assembly (Flat)	64	A77A4-1	Puck Springs (2)
10	A63A28-1	Fibre Washer	65	A91A739-1	Puck Arm & Plate Assembly—Take-up
11	A63X29-1	Felt Spacer .257 I.D. x 7/16 O.D. x 1/16 Th.	66	A75A44-1	Take-up Puck Plate Spacer (2)
12	A76A8-1	Guide Roller Shaft	67	A91A26-1	Drive Puck Assembly 2½"
13	A75A11-1	Spacer	68	A63A19-1	Fibre Washer
14	A61X565-1	Screw, Mach. 2-56 x ¾ Fillister Hd. N.P. (4)	69	A67A12-1	Hairpin Retainer
15	A91A17-1	Erase Head Assembly	70	A91A26-1	Drive Puck Assembly 2½"
16	A77A25-1	Head Adjusting Spring (2)	71	A77A4-1	Puck Springs (2)
17	A87A8-1	Knob with Set Screws (2)	72	A31B130-1	Solenoid
18	A62X186-1	7/16-20 Hex Nut Steel N.P.	73	A67X7-1	3-32 x ½" Drive Loc. Pin
19	A75A96-1	Safety Knob	74	A63A8-1	Felt Washer
20	A61X111-1	#4-40x5/16 Phillips B.H.M.S. St. N.P.	75	A78A22-1	Bearing Retainer
21	A63A5-1	Dural Washer	76	A74A21-1	Capstan Bearing
22	A63A28-1	Fibre Washer	77	A76A2-1	Pressure Arm Shaft
23	A91A10-1	Roller & Bearing Assembly (Flanged)	78	A63A78-1	Washer
24	A63A28-1	Fibre Washer	79	A91A11-1	Pressure Arm Assembly
25	A63X29-1	Felt Spacer .257 I.D. x 7/16 O.D. x 1/16 Th.	80	A91A214-1	Pressure Arm Plate Assembly
26	A76A8-1	Guide Roller Shaft	81	A63X103-1	Washer
27	A75A11-1	Spacer	82	A67X13-1	Retaining Ring
28	A91A56-1	Top Shield & Lining Assembly	83	A91A765-1	Capstan Shaft Assembly
29	A91A57-1	Record & Reproduce Head Final Ass'y.	84	A78X28-1	Ball Bearing
30	A87A14-1	Control Knob with Set Screws	85	A91A216-1	Puck Arm & Plate Assembly—Drive
31	A75A37-1	Control Sleeve	86	A75A45-1	Puck Plate Spacer—Long
32	A61A656-1	4-32x3/8 Knurled H.M.S. Brass	87	A91A216-1	Puck Arm & Plate Assembly—Drive
33	A75A16-1	7½" Capstan 60 Cycle (Not Shown in Exploded View)	88	A75A44-1	Washer
	A75A15-1	15" Capstan 60 Cycle (Shown in Exploded View)	89	A63X5-1	Control Sleeve Washer (Part of Item 31)
34	A61X647-1	4-36 x 5/16 Knurled H.M.S. Brass	90	A62X159-1	Control Sleeve Nut (Part of Item 31)
35	A91A14-1	7½" Pressure Roller Ass'y 60 Cycle (Not Shown in Exploded View)	91	A74A66-1	Cam
	A91A15-1	15" Pressure Roller Ass'y 60 Cycle (Shown in Exploded View)	92	A61X692-1	6-32 x 3/16 Allen Set Screw (2)
36	A91A51-1	Take-up Shaft & Bayonet Spindle Ass'y	93	A76A39-1	Switch Shaft
37	A91A52-1	Take-up Bearing & Housing Assembly	94	A67X13-1	¼" Tru-Arc Retaining Ring
38	A75A63-1	Take-up Hub Tube	95	A91A31-1	Safety Shaft & Pin Assembly
39	A75A62-1	Take-up Hub Flange	96	A77A1-1	Safety Shaft Spring
40	A63A9-1	Felt Washer	97	A71B58-1	Left Hand Side Panel
41	A91A38-1	Take-up Wheel & Bearing Assembly	98	A75A282-1	Spacer, Long Rewind Motor (2)
42	A63A9-1	Felt Washer	99	A91A918-1	Spacer, Short with Bumper, Rewind Motor (2)
43	A63A10-1	Brass Washer	100	NOT USED	
44	A63A11-1	Rubber Washer	101	A75A283-1	Motor Spacer (2)
45	A75A70-1	Locknut	102	A91C892-1	Rewind Motor
46	A61X159-1	8-32 x ½" Lg. Allen Hd. Cap. Screw	103	C72B169-1	Pawl Mounting Plate Bracket
47	A77A35-1	Spring	104	A71A319-1	Pawl Mounting Plate
48	A71B41-1	Right Half Side Panel	105	A71A87-1	Pawl
49	A62X10-1	Hex Nut, No. 6	106	A75A85-1	Rewind Hub Tube
50	A72A42-1	Puck Arm Bracket	107	A61X368-1	8-32 x 3/16 Allen Head Set Screw
51	A91A217-1	Lever Mounting Bracket & Stud Assembly	108	A75A84-1	Rewind Hub Flange
52	A78A13-1	Wire Link Short	109	A63A9-1	Felt Washer
53	A78A91-1	Pivot Arm	110	A77A2-1	Pawl Spring
54	A78A12-1	Wire Link	111	A75A86-1	Ratchet
55	A63A98-1	Capstan Shaft Spring Washer (2)	112	A63A9-1	Felt Washer
			113	A63A10-1	Brass Washer
			114	A63A11-1	Rubber Washer
			115	A91A70-1	Locknut Assembly
			116	A61X159-1	8-32 x ½" Lg. Allen Head Cap Screw

MECHANICAL PARTS LIST (Continued)

ITEM NO.	PART NO.	DESCRIPTION
117	A91C2-1	Back Panel Assembly
118	A75A30-1	Thrust Housing
119	A62X153-1	¼-20 Hex Nut x 7/16 St. N.P.
120	A61A18-1	¼-20 x ½ Set Screw—Thrust
121	A35B49-1	Drive Motor, Hys.Sync., 2-Sp. 900-1800 RPM

ITEM NO.	PART NO.	DESCRIPTION
122	A77A6-1	Pressure Arm Spring
123	A91A30-1	Switch Arm & Pin Assembly
124	A72A3-1	Switch Mounting Bracket
125	A43X14-1	Switch D.P.S.T. (2)
126	A91B736-1	Control Linkage Assembly

BIAS OSCILLATOR

ITEM NO.	SCH. REF.	PART NO.	DESCRIPTION
127	V1	A97X7-1	Bias Oscillator
128	R7	A14X32-1	Bias Oscillator, Control, 10K, ½W
129	J2	A55X4-1	Jones Plug, 10-Prong, Male
130	TB1	A56X1-1	Barrier, Terminal Strip
131	J1	A54X2-1	Receptacle, Cannon, Female
132	R3	A11X2-1	Resistor, 10K, ½W
133	C7	A28X1-1	Capacitor, Ceramic Disc., .01 mfd, 400V
134	C9	A28X2-1	Capacitor, Ceramic Tub., .1 mfd, 600V
135	R7	A14X32-1	Bias Oscillator, Control, 10K, ½W
136	C8	A28X2-1	Capacitor, Ceramic Tub., .1 mfd, 600V
137	R6	A11X21-1	Resistor, 47 Ohm, 1W
138	C15A,		
	B	A23X10-1	Capacitor, Elect., 20 mfd, 150V
139	CR1	A42A5-1	Selenium Rectifier, 150MA, 150V
140	C1	A26X8-1	Capacitor, Bathtub, .1 mfd, 600V
141	R5	A11X129-1	Resistor, 220 Ohm, 2W
142	C4	A21X1-1	Capacitor, Mica, .0025 mfd, 500V

ITEM NO.	SCH. REF.	PART NO.	DESCRIPTION
143	C6	A21X4-1	Capacitor, Mica, 50 mmf, 500V
144	L1	A31A6-1	Bias Oscillator Coil
145	C2	A21X6-1	Capacitor, Mica, .002 mfd, 500V
146	R2	A11X10-1	Resistor, 22K, ½W
147	C3	A21X6-1	Capacitor, Mica, .002 mfd, 500V
148	R1	A11X10-1	Resistor, 22K, ½W
149	R4	A11X14-1	Resistor, 100 Ohm, ½W
150	C5	A21X4-1	Capacitor, Mica, 50 mmf, 500V
151	C11	A28X2-1	Capacitor, Ceramic Tub., .1 mfd, 600V
152	C10	A28X2-1	Capacitor, Ceramic Tub., .1 mfd, 600V
153	C14	A21X21-1	Capacitor, Mica, .0068 mfd, 300V
Sch.	C13	A22X15-1	Capacitor, Ceramic, Tub., .1 mfd, 600V
Sch.	C14	A22X15-1	Capacitor, Ceramic, Tub., .1 mfd, 600V
Sch.	C12	A22X8-1	Capacitor, Oil, 6 mfd, 220V
Sch.	DS1	A41X11-1	Neon Bulb, Recording Indicator #NE-51

AMPLIFIER

ITEM NO.	SCH. REF.	PART NO.	DESCRIPTION
154	S3	A43X20-1	Meter Switch, Leaf Type
155			Pilot Lamp — VU Meter
156		A91B87-1	Equalizing Network, Plug-in
157	M1	A46B22-1	VU Meter
158			Pilot Lamp — VU Meter
159	T3	A32B30-1	Transformer, Output
160	R34	A12X20-1	Resistor, 25 Ohm, 10W, Wire Wound
Sch.	C13A	A23X9-1	Capacitor, Elect., 40 mfd., 450V
Sch.	C13BA	A23X9-1	Capacitor, Elect., 30 mfd., 450V
Sch.	C13OA	A23X9-1	Capacitor, Elect., 10 mfd., 450V
Sch.	C13DA	A23X9-1	Capacitor, Elect., 20 mfd., 450V
163	S2	A43X16-1	Power Switch, SPST, Bat Handle Toggle
164	T1	A32B29-1	Power Transformer, 700V
165	V6	A97X62-1	Rectifier, 573
166	V4	A97X101-1	Audio Output
167	V5	A97X109-1	Audio Output
168	V2	A97X143-1	AF Amplifier, 12SJ7
169	V3	A97X63-1	AF Amplifier, Phase Inverter, 6SL7
170	V1	A97X13-1	Recorder — Mic. Preamp
171	T2	A32B1-1	Input Transformer, Triad 3213
172	J3	A54X2-1	Receptacle, Female, Cannon
173	C2	A23X12-1	Capacitor, Elect., 25 mfd., 25V
174	J2	A55X10-1	Receptacle, Male, Cannon
175	J1	A57X4-1	Phone Jack
176	C11	A23X12-1	Capacitor, Elect., 25 mfd., 25V
177	C5	A23X12-1	Capacitor, Elect., 25 mfd., 25V
178	C16	A23X12-1	Capacitor, Elect., 25 mfd., 25V

ITEM NO.	SCH. REF.	PART NO.	DESCRIPTION
179	TB1	A56X3-1	Terminal Strip, 5 Contact
180	C10	A22X3-1	Capacitor, Paper Tub., .05 mfd, 400V
181	J4	A54X1-1	Socket, 6 Contact, Female, Jones
182	CR1	A42X6-1	Selenium Rectifier, 800ma (4) IN 2070, Diodes Bridge Couting.
183	F1	A53X10-1	Fuse, 3 amp
184	C4	A22X78-1	Capacitor, Molded Tub., .005 mfd, 400V
185			Deleted
186	C17	A23X12-1	Capacitor, Elect, 25 mfd, 25V
187	S4	A43X74-1	Equalization Switch, Rotary Wafer Type
188			Deleted
189	J5	A57X4-1	Phone Jack
190	C8	A22X3-1	Capacitor, Paper Tub., .05 mfd, 400V
191	C15	A23X1-1	Capacitor, Elect. 1000 mfd., 25V 25V Tubular
192	C18	A21X26-1	Capacitor, Mica, 75 mmf, 1500V
193	C12	A21X6-1	Capacitor, Mica, .002 mfd, 500V
194	S1	A43A122-1	Switch, Function, Rotary Wafer
195	C7	A22X3-1	Capacitor, Paper Tub., .05 mfd., 400V
196	C6	A22X3-1	Capacitor, Paper Tub., .05 mfd., 400V
197	C9	A21X5-1	Capacitor, Mica, .0004 mfd., 500V
198	C3	A22X15-1	Capacitor, Ceramic Tub., .1 mfd., 400V
199	C1	A21X6-1	Capacitor, Mica, .002 mfd., 500V
200	R1	A13X7-1	Resistor, 47K, 5%, ½W
201	R4	A11X67-1	Resistor, 100K, 1W
202	R2	A11X28-1	Resistor, 1500 Ohm, 1W
203	R3	A11X34-1	Resistor, 15K, 1W
204	R35	A13X15-1	Resistor, 43 Ohm, 5%, 1W
205	R11	A11X8-1	Resistor, 3900 Ohm, ½W

AMPLIFIER (Continued)

ITEM NO.	SCH. REF.	PART NO.	DESCRIPTION	ITEM NO.	SCH. REF.	PART NO.	DESCRIPTION
206	R6	A11X15-1	Resistor, 820 Ohm, 1/2W	224	R14	A11X8-1	Resistor, 3900 Ohm, 1/2W
207	R7	A11X67-1	Resistor, 100K, 1W	225	R8	A11X4-1	Resistor, 470K, 1/2W
208	R12	A11X138-1	Resistor, 56K, 1W	226	R15	A11X9-1	Resistor, 100K, 1/2W
209	R22	A11X6-1	Resistor, 270K, 1/2W	227	R5	A14X21-1	Control, Gain, 100K, 1/2W
210	R17	A12X29-1	Resistor, 250 Ohm, 5W	228	L1	A31X5-1	Coil, Adjustable
211	R13	A11X14-1	Resistor, 100 Ohm, 1/2W	229	R27	A11X8-1	Resistor, 3900 Ohm, 1/2W
212	R21	A13X3-1	Resistor, 620 Ohm, 5%, 1/2W	230	R23	A13X7-1	Resistor, 47K, 5%, 1/2W
213	R18	A11X112-1	Resistor, 100K, 2W	231	R30	A11X11-1	Resistor, 330 Ohm, 1/2W
214	R33	A12X4-1	Resistor, 2000 Ohm, 10W	232	R31	A11X11-1	Resistor, 330 Ohm, 1/2W
215	R25	A11X2-1	Resistor, 10K, 1/2W	233	R28	A11X28-1	Resistor, 1500 Ohm, 1W
216	R20	A12X4-1	Resistor, 2000 Ohm, 10W	234	R29	A11X28-1	Resistor, 1500 Ohm, 1W
217	R32	A14X6-1	Control, Speaker Volume, 30 Ohm, 4W			A53X5-1	Fuse Holder
218	R24	A11X2-1	Resistor, 10K, 1/2W			A87B17-1	Control Knobs, 4 Used
219	R19	A11X6-1	Resistor, 270K, 1/2W	C14AA23X23-1			Capacitor, Elect., 20 mfd., 450V
220	R26	A13X7-1	Resistor, 47K, 1/2W	C14BA23X23-1			Capacitor, Elect., 20 mfd, 450V
221	R20	A12X4-1	Resistor, 2000 Ohm, 10W, Wire Wound	C14CA23X23-1			Capacitor, Elect., 20 mfd., 450V
222	R9	A11X4-1	Resistor, 470K, 1/2W	C14DA23X23-1			Capacitor, Elect., 20 mfd., 450V
223	R10	A11X138-1	Resistor, 56K, 1W				
	R36		4.7Ω 1W 10% Resistor				

NOTES:

- 1. ALL CAPACITORS ARE IN MFD. UNLESS OTHERWISE SPECIFIED.
- 2. CAPACITOR VALUE (C12) MAY DIFFER WITH DIFFERENT MOTOR. CHECK NAME PLATE OF MOTOR FOR VALUE.
- 3. ALL RESISTORS IN OHMS, $\frac{1}{2}$ W, 10% UNLESS OTHERWISE NOTED.

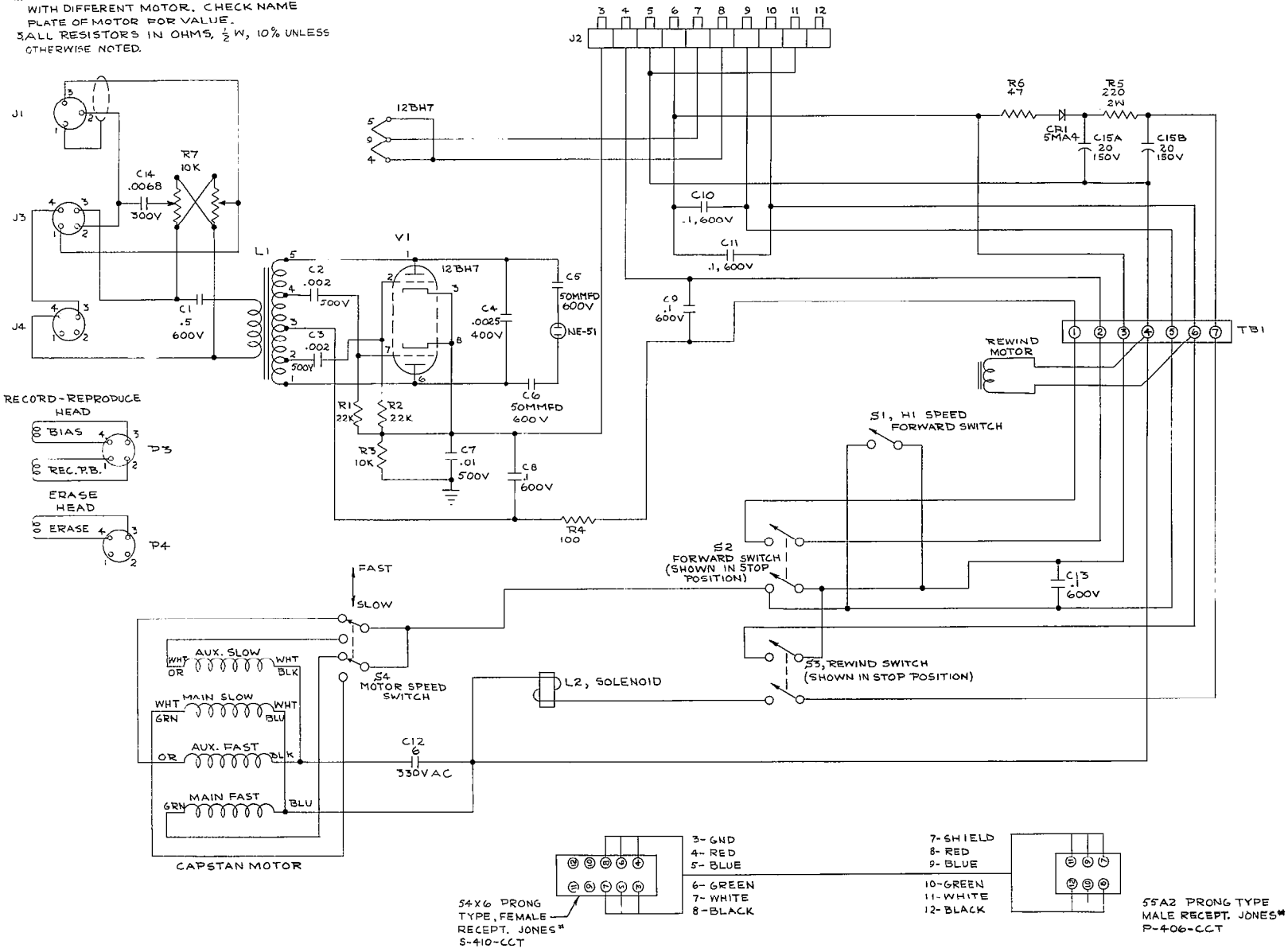

INTERCONNECTING CABLE

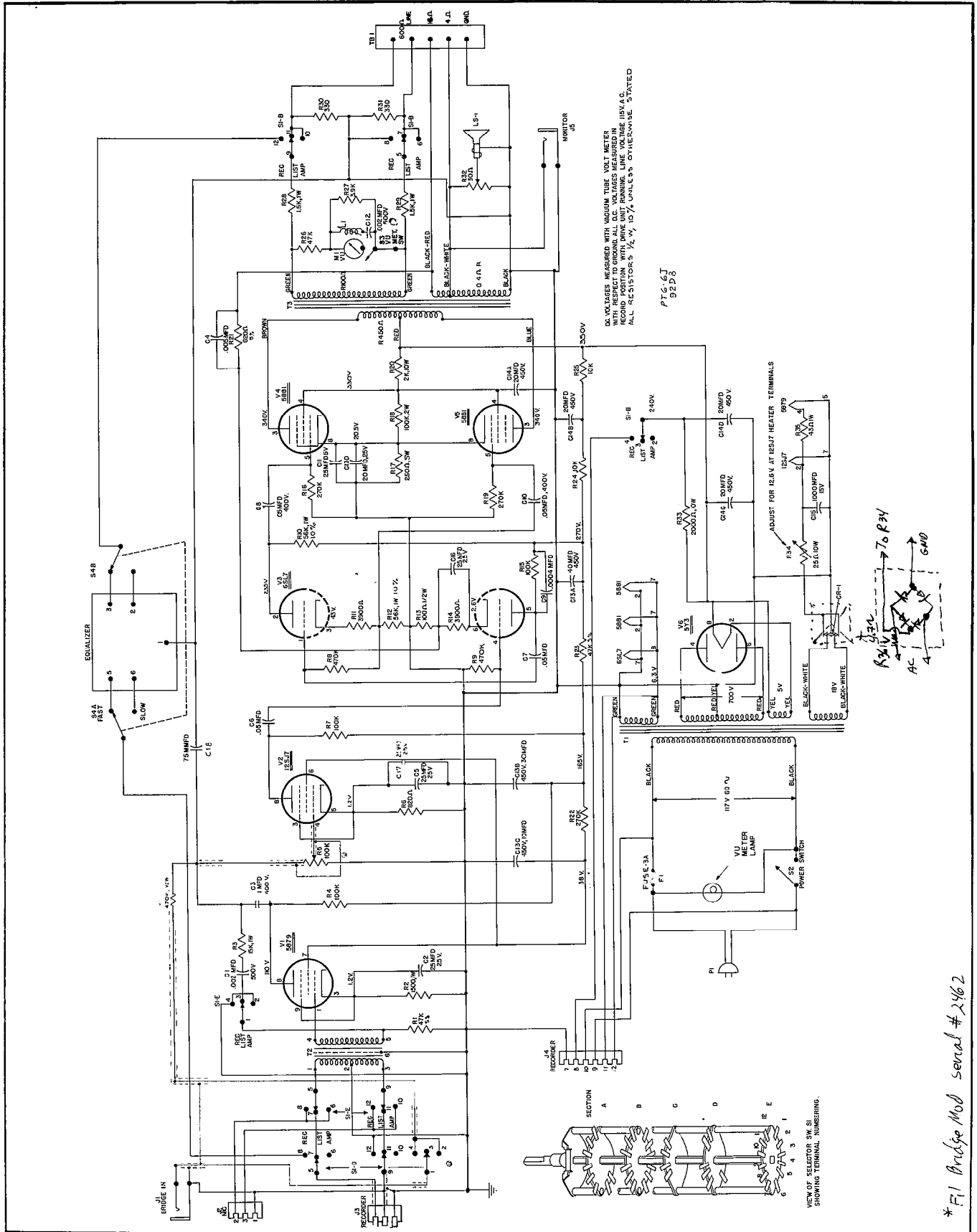

Amplifier Schematic Models PT6-J, PT6-6J.

*F1 Bridge Mod serial # 2462