

SYNCHRONIZATION
of
Westinghouse Radio Stations
WBZ and WBZA



WESTINGHOUSE RADIO STATIONS, INC.

ENGINEERING DEPARTMENT

1625 K Street N. W., Washington 6, D. C.

Synchronization
of
Westinghouse Radio Stations
WBZ and WBZA

S. D. Gregory
Radio Engineer
Radio Operations Department

SYNCHRONIZATION OF WESTINGHOUSE RADIO STATIONS WBZ AND WBZA

Radio Station WBZ was installed on the roof of the Westinghouse plant in East Springfield, Massachusetts, in September, 1921. It was the first radio station in the United States to be granted a license exclusively for broadcasting, although Westinghouse Station KDKA had been operating a radio telephone transmitter since October, 1920, under a special authorization. WBZ's original license specified an operating wavelength of 360 meters and a power output of 1500 watts - a comparatively high power for those days.

The studio for WBZ was located in Springfield and depended entirely upon local talent for program material. It was soon evident that those facilities were inadequate and a studio was installed in Boston, where a much more diversified array of talent was available. The new studio proved a boon to the listeners in and around Springfield but at the same time it created an embarrassing condition in Boston. Signals from the East Springfield transmitter were not heard in that area at all well and the artists complained that their friends could not hear them broadcast.

In order to make the programs from WBZ available to the listeners in Boston it was decided to build a second station there. The new transmitter was installed in the Brunswick Hotel, where the Boston studio was located, and was first put in operation in November, 1924, under the call letters WBZA. It was a self-excited set, operating on 242 meters, with a power output of 250 watts, and, although it was a makeshift affair at the best it remedied the situation in Boston.

An interesting fact in connection with WBZA is that it was the first broadcasting station to use a piezo electric oscillator for controlling its frequency. This apparatus was first installed in March, 1925, and similar equipment was placed in service at WBZ shortly after.

During the following months the first attempts to operate both WBZ and WBZA on the same frequency (900 kilocycles) were made, using crystals ground to zero beat. The results were far from satisfactory, due primarily to the fact that no precautions were taken to keep either the supply voltages or the crystal oscillator temperature constant. The listeners in the suburbs of Boston were troubled with a heterodyne of varying frequency when both stations were operating. After a short trial the two stations went back to their original set-up, carrying the same program on separate frequencies.

In April, 1926, true synchronization of the two stations was attempted. The land wire which ordinarily carried the program between Springfield and Boston was used to transmit the synchronizing frequency as well. In order to keep the number of frequency multiplier stages to a minimum, fifty kilocycles was chosen as the carrier frequency for the first trials. The line used was an ordinary telegraph circuit consisting of open wire with the exception of a two mile section of cable and twisted pair at Worcester, and another fifteen mile section at the Boston end.

A schematic diagram of the original frequency multiplying equipment used at the two stations is shown in Fig. 1. At WBZ the 50 kilocycle piezo

oscillator excited both the first harmonic amplifier and the line amplifier. At that time buffer amplifiers were unheard of. The harmonic amplifiers, of which there were three, utilized the second or third harmonic in each case, the frequencies used being 50 kilocycles, 150 kilocycles, 450 kilocycles, and 900 kilocycles. Two hundred fifty watt tubes were used in the harmonic amplifiers and a 250 watt power amplifier stage at 900 kilocycles excited the output stage. The 250 watt line amplifier supplied about 125 watts of 50 kilocycle energy to the line. The transmitter at WBZA was similar to the one at East Springfield, except that it used 50 watt tubes in the harmonic amplifiers and had a power output of 250 watts.

In spite of all the precautions taken to insure good transmission, in foggy or rainy weather the incoming 50 kilocycles at Boston invariably dropped off to below a useable level. At first the source of trouble was thought to be the section of cable and twisted pair at Worcester, but measurements of the synchronizing frequency at that point showed the same wet weather characteristics as at the Boston end. After making a thorough investigation it was decided that the transmission frequency was too high. When the crossarms became wet the metal insulator pins were connected together by a high resistance path, and the water on the insulators greatly increased the capacity from line to pins. The resulting increase in charging current caused a corresponding increase in power loss along the line and accounted for the higher attenuation during damp weather.

The frequency was lowered to 25 kilocycles and an additional multiplier

stage was added at both stations. At that time there were no 25 kilocycle crystals available, so a stable master oscillator was built, using a UX-210 tube. On May 20, 1926, the new synchronizing setup was tried out and the results were encouraging. Tests were continued until July 5th, 1926, at which time the two stations commenced synchronous operation on regular schedules.

The setup just described was operated for more than a year with only minor changes. Very little difficulty was had with the synchronizing apparatus; what trouble occurred was due largely to the fact that the grounding system at the Brunswick Hotel was very unsatisfactory, the building being of frame construction. As it was impossible to remedy this difficulty, arrangements were made to move to the top floor of the Statler Hotel. A complete new transmitter was constructed and was placed in operation in June, 1927. The new set differed from the Brunswick transmitter chiefly along constructional lines, the electrical details being substantially the same. Improved filters were installed for separating the radio and audio at the Boston terminal of the synchronizing line.

At several times during the transition period three transmitters: WBZ at East Springfield, and the old and new WBZA outfits at Boston were successfully operated in synchronism - the first time that this had been done in this country. The new transmitter put a much stronger signal into Boston, due to the improved antenna system, to an increase in power to 500 watts and to the higher percentage of modulation of which it was capable. A few months later similar multiplier and low power amplifier stages were built

for WBZ. Both of the new transmitters gave satisfactory service and were operated for more than two years with no major changes in equipment.

On November 11, 1928, the new allocation plan for the broadcast spectrum went into effect and the frequency of Stations WBZ and WBZA was changed to 990 kilocycles. Shortly after the change was made listeners began to complain about interference from harmonics from WBZ. These harmonics were in reality combinations of the various multiplier frequencies resulting in modulated radiations within the broadcast band. Previous to the reallocation these radiations happened to fall on broadcast channels in which reception was already ruined by cross-talk and heterodyning. The use of 990 kilocycles shifted the interference to frequencies occupied by cleared channel stations, and listeners immediately registered protests. A re-adjustment of the harmonic amplifiers helped the situation temporarily and new equipment, which will be described shortly, gave permanent relief.

Another effect of the frequency change was a marked decrease in signal from the two stations around the outer edge of their service areas. Even the comparatively small increase of ninety kilocycles was enough to cause a noticeably higher attenuation.

In December, 1929, improved frequency multiplying equipment was installed at WBZA, using UX-210 tubes in place of the larger power tubes. Three of the multiplier stages were replaced by a multivibrator, operating from 55 kilocycles to 990 kilocycles. As an additional precaution against the radiation of any harmonic frequencies a crystal filter was installed between the multivibrator and the 990 kilocycle power amplifiers.

The multivibrator setup proved satisfactory and a few months later similar equipment was installed at WBZ. That is, the construction of the apparatus was the same, but the multivibrators, of which there were two, were used as frequency dividers. The WBZ transmitter operated from a 990 kilocycle crystal the same as a conventional broadcast installation. The crystal oscillator output was also used to excite a multivibrator, which divided the frequency to 165 kilocycles. The second multivibrator further divided the frequency to 27.5 kilocycles, which was fed to the synchronizing line through a power amplifier consisting of four UV-845 tubes in parallel. Parallel operation of this type of tube effected a very efficient transfer of energy to the line. Suitable filter systems were used to keep the synchronizing tone from feeding back into the audio system and the audio from getting into the multivibrators. A schematic diagram showing the multivibrator equipment and associated apparatus at both stations is shown in Fig. 2. As mentioned before, this new equipment remedied the interference caused by unwanted radiations.

Although the synchronized operation of WBZ and WBZA gave satisfactory program service to Boston and Springfield it was rather an illogical arrangement as the 15 KW transmitter was located in the smaller of the two cities and the 500 watt set was in the larger. On the other hand, it was not desirable to locate a powerful transmitter within the limits of a large city. Inasmuch as a large part of the population of the New England states is concentrated in the three cities of Boston, Providence and Worcester, it was

decided to build a new station in some location which would adequately serve those cities and to move the WBZA transmitter to East Springfield to serve that area. After careful investigation as to elevation, accessibility to power and telephone lines, type of soil, etc., a location on Dover Road, about two miles northeast of Millis, Massachusetts, was tentatively chosen for the new station. A 500 watt test transmitter was set up and several weeks were spent in taking field strength measurements, using a portable checking set installed in a light truck. The three cities mentioned before were thoroughly covered in the survey, and, in addition, readings were taken along six radials in order that field intensity contours could be plotted. Data was available from which the probable output in meter amperes of the proposed 15 KW transmitter could be calculated, and a comparison of that value with the meter ampere output of the test transmitter gave the approximate coverage to be expected from the new station. As the three cities in question fell within the calculated good service area the Millis location was definitely decided upon and construction work was started immediately.

As the transmitter which was installed is an RCA coordinated set, Model 50-B, a detailed description is hardly necessary. Kaar and Burnside covered this type of transmitter in their paper, "Some Developments in Broadcast Transmitters," published in the Proceedings of the I. R. E. for October, 1930. However, there are a few points which it might be well to mention.

The usual duplicate crystal control units are incorporated in the transmitter. Additional equipment was installed for synchronizing the two stations as before, a new type of frequency multiplier being used. Fig. 3 shows

the details of the multiplying equipment and the method used for tying it in to the main transmitter. The apparatus is connected so that the Millis transmitter automatically changes to its own crystal oscillator in case the synchronizing tone from East Springfield drops below a certain level. When the level returns to normal the station automatically changes back to synchronized operation. A sensitive relay operated by the grid current in a low power 990 kilocycle saturated amplifier keeps the plate circuit of the crystal unit buffer stage open as long as the level of the synchronizing tone remains high enough to keep the grid current of the saturated amplifier above a certain value. Below that value the regular crystal unit functions normally and the relay opens the plate circuit of the saturated amplifier.

The synchronizing apparatus proper is located in the room which houses the station audio equipment. The incoming 27.5 kilocycle frequency passes through a band-pass filter which keeps the audio and any line interference from getting into the multiplying equipment. A two-stage 27.5 kilocycle amplifier feeds a coupling tube, the plate of which is connected to the tank circuit of a special 165 kilocycle oscillator. The second 27.5 kilocycle stage operating saturated, takes care of any small variations in the level of the incoming 27.5 kilocycles. The coupling tube, having its grid excited strongly by 27.5 kilocycles has a high percentage of harmonics in its output; consequently, the 165 kilocycle oscillator, oscillating at a frequency which is the sixth harmonic of 27.5 kilocycles locks in step with the exciting frequency. The oscillator could be made to lock in at any harmonic frequency within certain limits, but 165 kilocycles was chosen in order to arrive at the operating

frequency in two steps.

The output of the oscillator feeds through a coupling tube into a second oscillator operating under like conditions at the sixth harmonic of 165 kilocycles, thus producing the desired frequency, 990 kilocycles. The output of the second oscillator passes through a double crystal filter as shown in Fig. 3 and into a two-stage power amplifier, which feeds a transmission line running to the saturated amplifier located on the crystal control panel of the main transmitter. The transmission line, which is about 100 feet in length, is rather novel in that it consists of low capacity twin conductor lead cable running through an iron conduit.

In the original synchronizing setup it was possible to feed programs either way between Springfield and Boston. The erection of the Millis station introduced a new problem as the transmitter is situated between the two cities in which the studios are located. The synchronizing line, which also carries the audio, was re-routed through Millis at the Boston end, the section between those two cities carrying program only. Figure 4 shows the present audio layout.

Two bridging amplifiers are used in the line terminating equipment at Millis. The output of one feeds the transmitter, the other acts as a repeater and feeds audio to the studio which is not furnishing the program. That is, to Boston when the program originated in the Springfield studio, and vice versa. The switching of amplifiers and lines is done by relays controlled by the announcer at the Boston studio. In this way the switching takes place automatically as the program source is transferred from one city to the

other. The line terminal and switching equipment, including amplifiers, volume indicators, relays and rectifiers is provided in duplicate, so that in case of trouble the spare set may be used. The sub-harmonics of the synchronizing frequency are kept out of the audio equipment by means of low-pass filters which cut off at about 8000 cycles.

Monitoring facilities are so arranged that the station operator can monitor the program on the line, at either stage of the speech amplifier, or, by means of a rectifier at the output of the final radio frequency power amplifier. A microphone control and amplifier are provided so that announcements can be made from the station during test work or in case of emergency. All amplifiers have separate rectifiers for plate supply, using 280 type tubes. Filament power for both the audio and synchronizing equipment is supplied from a 12 volt battery.

Low level modulation is used, the last three power amplifier stages being operated as Class B amplifiers. The output stage has been modified to use six UV-207 tubes, three on a side, in place of two UV-862s, giving a maximum rated carrier power of 15 kilowatts. The transmitter is normally modulated 100%, an oscillograph being used to check the modulation. The manufacturer's design specifications call for a frequency response flat within two decibels from 30 to 10,000 cycles, and within one decibel from 100 to 5,000 cycles.

Power is fed to the antenna over a two wire transmission line terminated in a tuned tank circuit of the correct impedance to match the characteristic impedance of the line. The antenna is a vertical cage supported between two

300 foot insulated steel towers spaced about 700 feet apart. Both a fan counterpoise and a buried wire ground are used, the combination of the two giving considerably better results than either one separately.

In reviewing the development of synchronizing of broadcasting stations as carried on by Westinghouse, it is evident that many problems have had to be worked out. A brief discussion of these might be of interest. Inasmuch as the backbone of any synchronizing system is the method or source of frequency control that subject will be discussed first.

The methods of control with which our engineers have experimented are master oscillator, piezo oscillator, and tuning fork. As stated previously, a master oscillator was used for some time at Stations WBZ and WBZA. The circuit was a regular Hartley with a high capacity tank, using a special Litz wound inductance. It was found necessary to carefully filter the power supply in order to prevent the ripple from the filament machine from causing frequency modulation of the oscillator output. The frequency stability of the stations when operating from master oscillator control was well within the required limits. In fact, for several years WBZ was listed in the Radio Service Bulletin of the Department of Commerce as a constant frequency station.

Mention has already been made of the use of matched crystals for controlling the simultaneous operation of two stations. Westinghouse engineers gave the idea a trial in 1925 but the art of grinding crystals to narrow limits had not advanced enough to warrant further experimental work along that line. However, the use of a master piezo oscillator to control the synchro-

nized operation of two or more stations had proven very successful as long as the usual precautions are taken against variations in temperature, load and supply voltages.

While we are on the subject of quartz crystals it might be in line to say a few words about crystal filters. Westinghouse engineers have been working on this problem for several years and were the first to make use of such a filter in connection with a radio transmitter. A crystal filter acts as an extremely narrow band-pass and the use of two or more crystals in cascade results in practically a point-pass filter.

The use of a tuning fork as the master control for synchronized operation was not found necessary at WBZ as the characteristics of the line between the two stations made possible the use of frequencies above the usual range of tuning forks. However, in the experimental synchronization of KYW and KDKA in 1927 it was necessary to use a lower tie-in frequency and a tuning fork was chosen as the logical source of control frequency. In that case a master fork operating at 5,000 cycles controlled the frequency of the KDKA transmitter through a system of harmonic amplifiers, and, in addition, was used to modulate a short wave transmitter. At Chicago the short wave signal was picked up and the 5 kilocycle tone was fed through a tuning fork stabilizer into similar harmonic amplifiers. In case of fading of the short wave signal the inertia effect of the stabilizer was sufficient to carry over until the end of the fade, then the incoming tone was automatically re-connected in the proper phase relation.

Another problem concerning which our engineers knew little when synchronizing was first attempted was the transmission of frequencies above the audio range over land wires. At the outset no extra precautions were taken to fit the lines for carrying the synchronizing frequency, but experience soon brought out the necessity of balancing the lines, using extra insulation, etc., in order to insure good transmission the year round. The problem was complicated in that the same line carried audio, telegraph, and telephone in addition to the tie-in frequency.

Over a long line such as the one between Boston and Springfield some difficulty due to electrical disturbances was to be expected. The trouble from that source proved to be slight, and has caused very little time off the air during almost five years of synchronized operation.

Continual research is being carried on in an effort to reduce the amount of equipment and number of tubes necessary for a synchronizing setup. To that end, several types of harmonic amplifiers, as well as the so-called multivibrator have been experimented with. Each type of frequency multiplier or divider has its advantages and disadvantages, depending upon the conditions under which it is to operate and upon the order of harmonic or subharmonic necessary in order to arrive at the final frequency. If a comparatively low order of harmonic, such as the second or third, is desired the ordinary harmonic amplifier in which a series of harmonics are produced in the output by strongly exciting a tube that is biased beyond cutoff, is to be recommended. Such an amplifier is also preferable from the standpoint of

stability inasmuch as it does not require a regulated power supply.

The special harmonic controlled oscillator which has already been described in connection with the Millis station has the advantage of producing an output comparatively free from unwanted sidebands. If operated from regular power sources it can be used to obtain as high as the eighth harmonic.

A multivibrator such as shown in Fig. 2 has an output rich in harmonics due to the fact that the plate current of each tube goes from zero to saturation during alternate half cycles. The frequency at which the plate current changes is dependent on the time of charge and discharge of the coupling condensers through the bias resistors. Under ordinary conditions it will operate satisfactorily when using as high as the tenth harmonic and, with well regulated supply voltages, up to the fortieth can be used for special applications. The disadvantage in using multivibrators in a synchronizing setup is that they are easily affected by cross-talk. Either audio or modulated radio getting into them will cause frequency modulation in their output.

The problem in connection with synchronizing which has been most widely discussed is the interference pattern which results when two broadcasting stations operate on the same frequency. In the case of Stations WBZ and WBZA, the bad quality area resulting from synchronized operation has been found to be quite limited and at no place within the service area of the two stations has the reception been poorer than it was found to be with either station alone. With the original synchronizing setup the area in question fell on the outskirts of Boston, between that city and Springfield, but very few

complaints of poor reception in that area were received.

In achieving success in the automatic synchronization of Westinghouse Stations WBZ and WBZA our engineers were forced to depart from prevailing practices in many instances and to carry on developments along new lines. Among the outstanding developments which have since come into more or less general acceptance were the first use of a quartz crystal for controlling the frequency of a broadcasting station, the use of matched crystals to control the simultaneous operation of two stations on the same frequency, the automatic synchronization of two or more stations by means of a tie-in frequency transmitted over land wires, the use of radio as a transmission medium for a synchronizing frequency, the use of a tuning fork as a stabilizer in connection with the synchronized operation of two stations and the use of a quartz crystal in the role of a narrow band-pass filter. For the past eight years Westinghouse engineers under the supervision of Dr. Frank Conrad have been engaged in experimental work on these and other problems associated with synchronization.

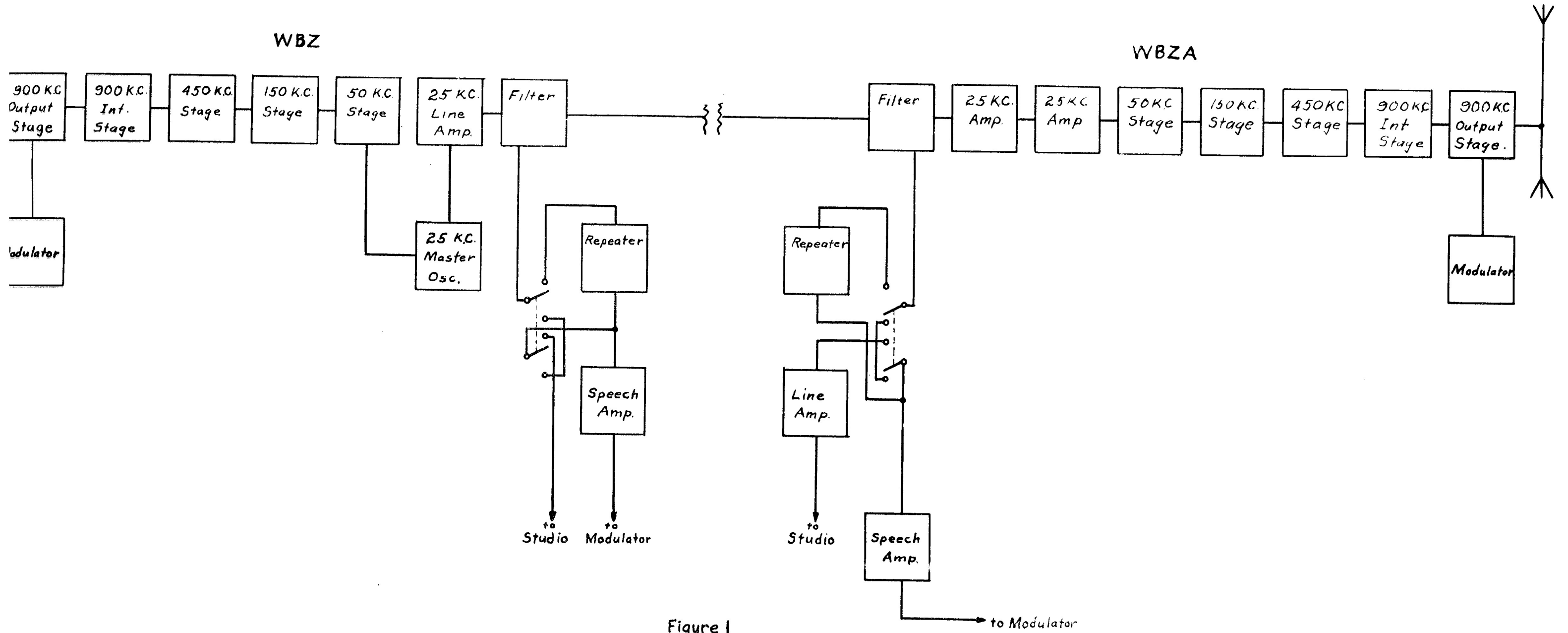

Figure 1

Dwg. No. _____

Sub. No. _____

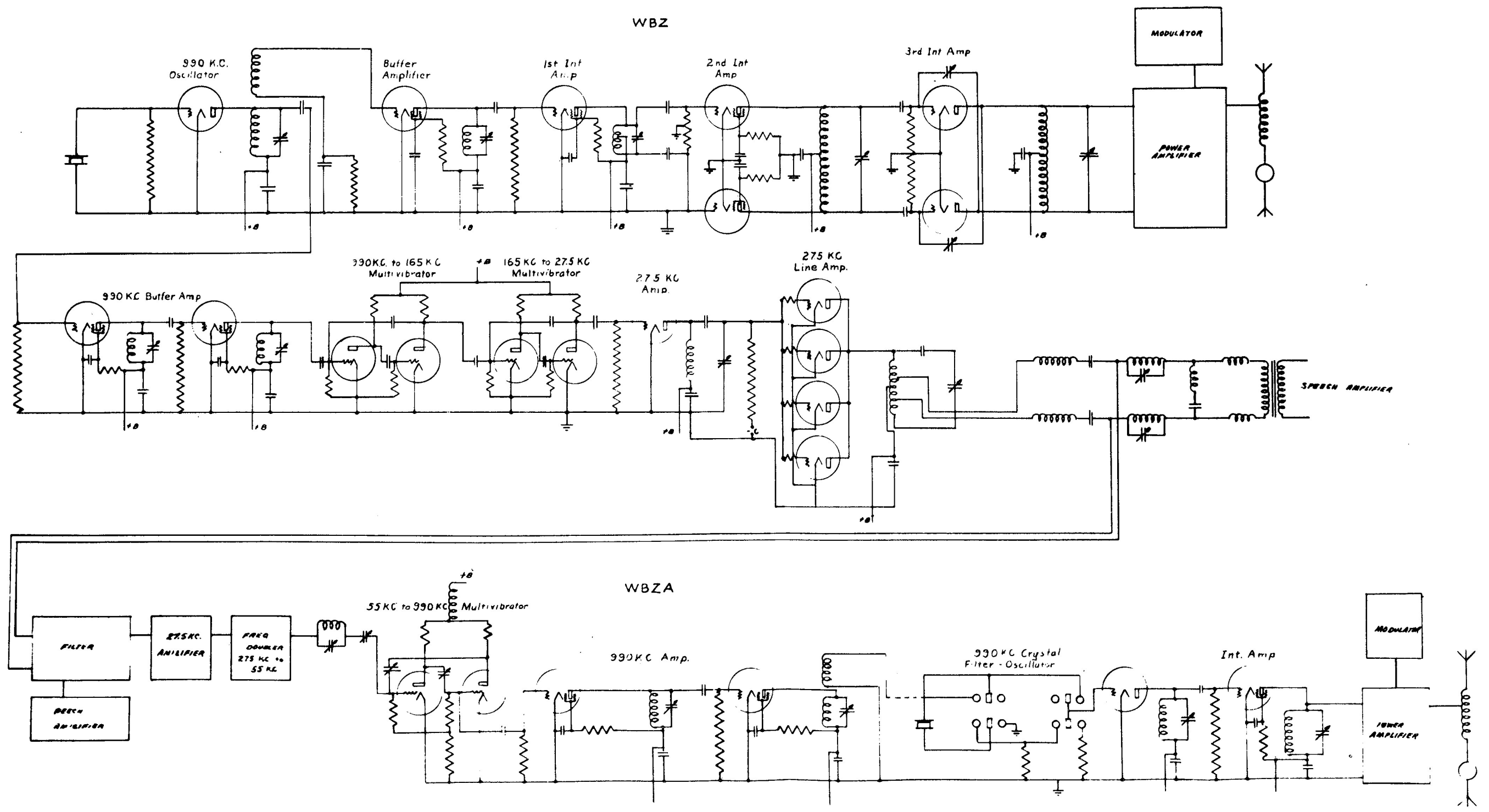

Figure 2

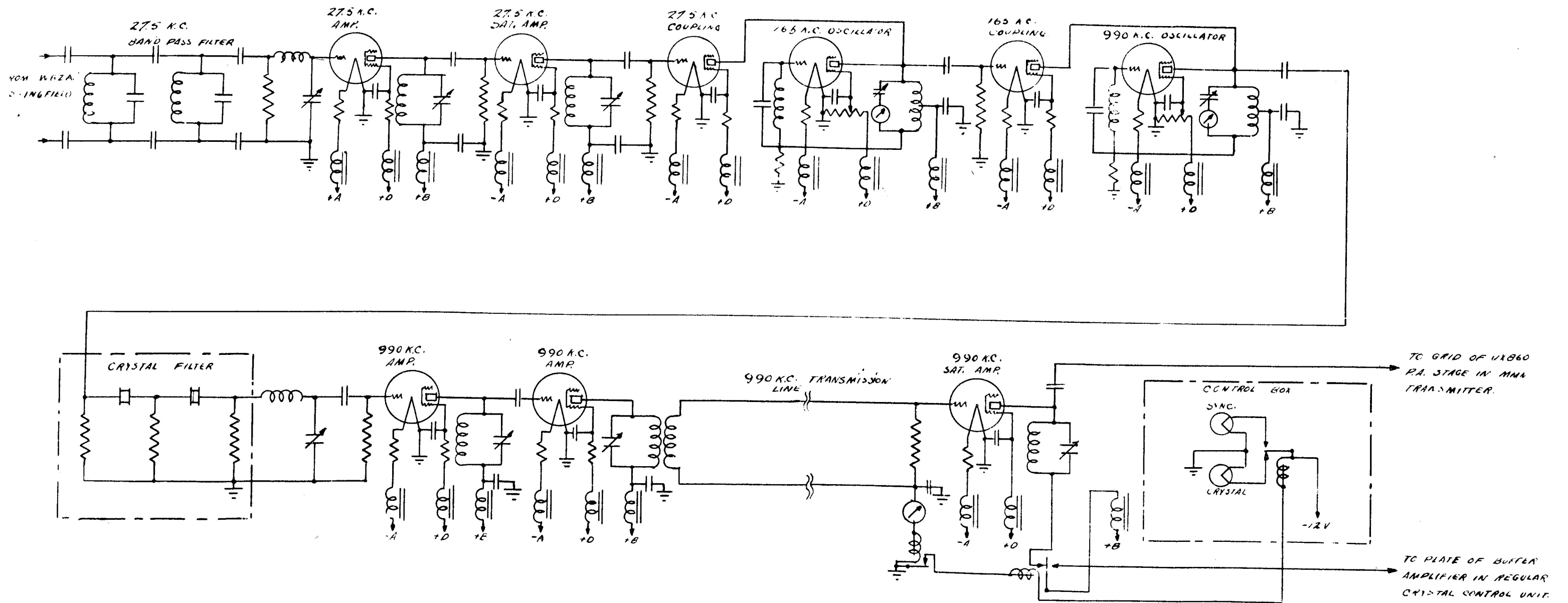

Figure 3

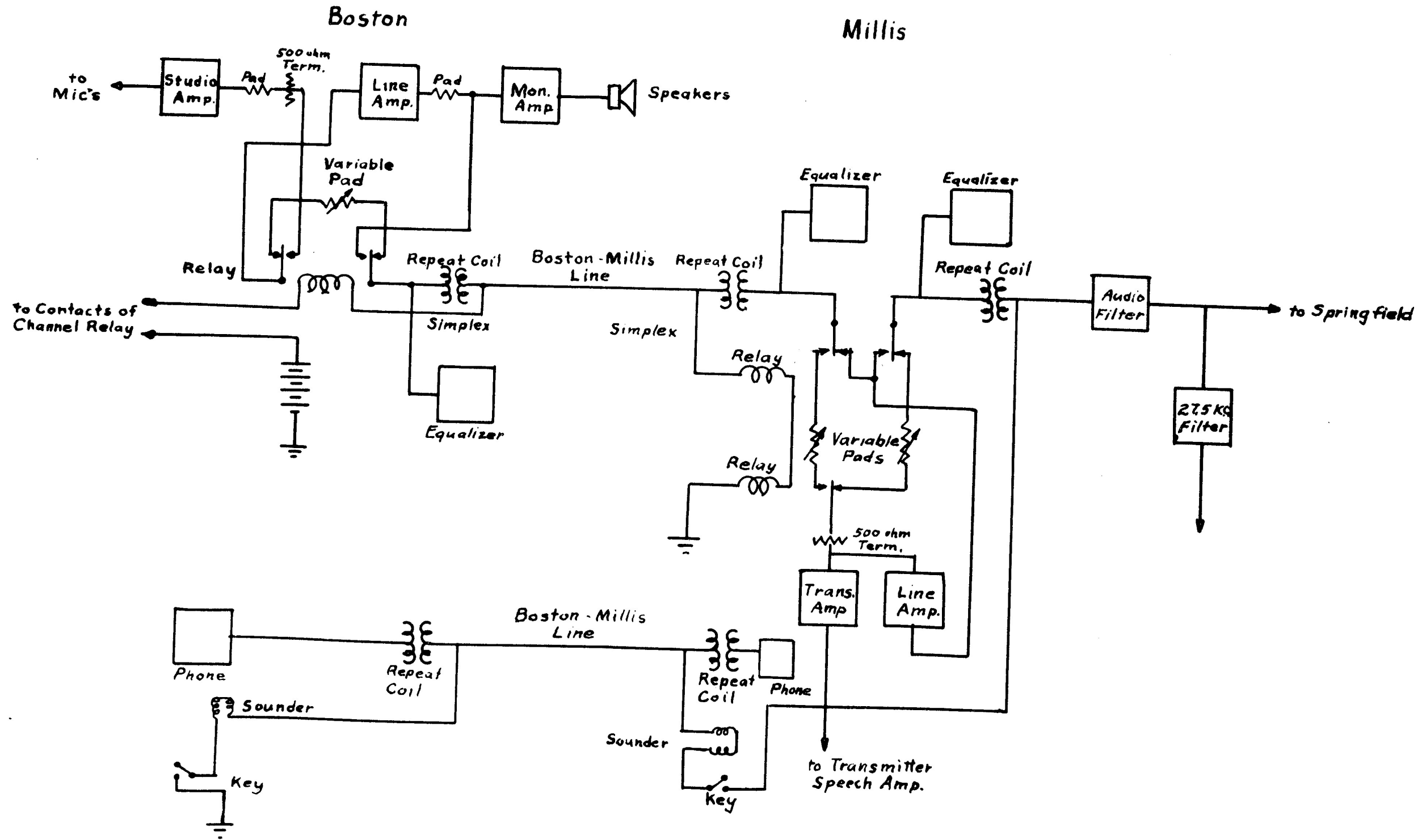

Figure 4

