

Serial No. _____

Revision Level C

Rev Date November 1979

AM MONITOR

MODEL 753

TIME & FREQUENCY TECHNOLOGY, INC.
3090 Oakmead Village Dr.
Santa Clara, California 95051

(408) 727-7272 TWX 910-338-0584

TABLE OF CONTENTS

	Page
SECTION 1	GENERAL INFORMATION
1.1	General Description 1-1
1.2	Specifications 1-1
1.3	Accessory Equipment 1-3
1.4	Warranty 1-4
1.5	Claim for Damage in Shipment 1-4
SECTION 2	INSTALLATION
2.1	Unpacking and Inspection 2-1
2.2	Power Requirements 2-1
2.3	Installation and Connections 2-1
2.4	Field Installation of Options 2-2
2.5	Model 704E Remote Meter Panel Connections... 2-2
SECTION 3	OPERATION
3.1	General 3-1
3.2	Turn-On and Warm-Up..... 3-1
3.3	Front and Rear Panel Controls & Connections... 3-1
3.4	Measurement of Modulation Using Modulation Meter.....3-4
3.5	Measurement of Modulation Using Peak Indicators 3-4
3.6	Measuring Residual Noise 3-5
3.7	Distortion Measurements 3-5
3.8	Use of the Model 704E Remote Meter and Flasher Panel 3-5
3.9	Connection of External Peak Counter 3-5
3.10	10 kHz Whistle Filter (Optional) 3-6
3.11	Telemetry Lowpass Output (Optional) 3-6
3.12	Carrier Power Alarm (Optional) 3-6
3.13	Modulation Alarm (Optional) 3-6
SECTION 4	THEORY OF OPERATION
4.1	Block Diagram 4-1
4.2	AM Detector and Audio Lowpass Filter and Summing Amp 4-2
4.3	AGC Circuit and Peak Flasher Reference Amp.. 4-3
4.4	Carrier Level Meter Driver 4-3
4.5	Inverting Amp and Audio Amp 4-3
4.6	Modulation Meter Amplifier 4-3
4.7	Peak Flashers 4-4
4.8	Calibration Signal Generator 4-4
4.9	Power Supplies 4-5

SECTION 5 MAINTENANCE Page

5.1	General	5-1
5.2	Periodic Maintenance	5-1
5.3	Field Installation of Options.....	5-1
5.4	Changing Meter Lamps	5-2
5.5	Calibration Procedures	5-2
5.5.1	Audio Attenuator Circuit	5-2
5.5.2	Carrier Level Meter	5-2
5.5.3	Peak Flashers	5-3
5.5.4	Modulation Meter	5-3
5.5.5	10 kHz Whistle Filter	5-3
5.5.6	Carrier Power Alarm	5-3
5.5.7	Modulation Alarm	5-3
5.6	Trouble Shooting Guide	5-4
5.6.1	Nothing Works	5-4
5.6.2	Carrier Level Meter Does Not Work	5-4
5.6.3	Modulation Meter Does Not Work	5-5
5.6.4	Variable Peak Flasher Does Not Work	5-5
5.6.5	-100%, Or +125% Peak Flasher Does Not Work.	5-6
5.6.6	Audio Outputs Do Not Work	5-6
5.6.7	Calibrate Circuit Does Not Work	5-6
5.6.8	Telemetry Lowpass Does Not Work	5-7
5.6.9	10 kHz Whistle Filter Does Not Work	5-7
5.6.10	Carrier Power Alarm Does Not Work	5-7
5.6.11	Modulation Alarm Does Not Work	5-8

SECTION 6 SCHEMATIC DIAGRAMS

6.1	Block Diagram
6.2	Wiring Diagram
6.3	Monitor Schematic
6.4	10 kHz Whistle Filter
6.5	Telemetry Lowpass
6.6	Carrier Power Alarm
6.7	Modulation Alarm
6.8	Rev B Monitor Schematic
6.9	Rev A Wiring Diagram

Peak Modulation Indicators

-100% Indicator	Internally set to flash when modulation exceeds -99%
Accuracy	±1% at 400 Hz
Frequency Response	±5% from 20 Hz to 25 kHz
+125% Indicator	Internally set to flash when modulation exceeds +125%
Accuracy	±1% at 400 Hz
Frequency Response	±5% from 20 Hz to 25 kHz
PEAK Indicator	30% to 150%, switchable to positive or negative peaks
Accuracy	±2% at 400 Hz
Frequency Response	±5% from 20 Hz to 25 kHz
Remote Output	Suitable for driving a Model 704E Remote Readout Panel

Audio Outputs

Audio Monitor Output	
Impedance	600 ohms unbalanced
Level	0 dBm at 600 ohms
Distortion	0.15% typical, 0.25% maximum, at 99%, 400-Hz modulation
Signal-to-Noise Ratio	> 75 dB below 100% modulation
Pulse Response	< 1% overshoot
Frequency Response	±0.5 dB from 20 Hz to 25 kHz
Audio Output	
Level	5V RMS into 5K ohms
Distortion	0.15% typical, 0.25% maximum, at 99%, 400-Hz modulation
Signal-to-Noise Ratio	> 75 dB below 100% modulation
Pulse Response	< 1% overshoot
Frequency Response	±0.5 dB from 20 Hz to 25 kHz

Carrier Fail Output

This output indicates loss of carrier by sinking a maximum +30 V DC, 50 mA load to ground at the rear-panel CARRIER ALARM terminal. Open collector output is normally off when carrier is present.

Modulation Calibrator

Accuracy	±1%
--------------------	-----

The built-in modulation calibrator generates a -100% +125% modulated carrier which is automatically switched into the detector input when the front-panel CAL button is depressed.

Options

Balanced Audio Monitor Output	
Impedance	600 ohms balanced
Level	0 dBm at 600 ohms

Carrier Power Alarm	Provides output on the same rear-panel terminal as the CARRIER FAIL alarm, when the input to the Monitor goes up by more than 5% or down by more than 10%.
10-kHz Whistle Filter	This switchable notch filter is placed in the audio output lines to minimize the 10-kHz tone from an adjacent carrier. Provides a minimum of 40 dB rejection at 10 kHz.
Telemetry Lowpass Output	An audio output lowpassed at 35 Hz is provided to drive subaudible telemetry equipment. Level is 0 dBm into 600 ohms for 5% modulation from 20 Hz to 30 Hz.
Modulation Alarm	Provides an "open collector" output which can sink a maximum +30 V DC, 50 mA load. This output is normally off, but shorts to ground when the modulation drops below 10% for a specified period of time. This delay time is internally adjustable from approximately 2 seconds to 30 seconds.
Power Required	117 VAC, 50 to 400 Hz, 300 W maximum; 230 VAC on request
Physical Characteristics	
Operating Temperature	0° C to 50° C
Cabinet Style	19" rack mounting
Cabinet Size	19" wide by 5-1/4" high by 14" deep

1.3 Accessory Equipment

1.3.1 Model 704E Remote Readout Panel

This remote modulation meter and peak flasher panel duplicates the corresponding front-panel indications. It connects to terminals on rear-panel strip J1 of the Model 753 through a 6-conductor cable. Power for operation of the Model 704E and drive for the remote meter and peak flashers are supplied by the Model 753.

1.3.2 Model 754 AM RF Preselector

This digitally tunable preselector allows remote, off-the-air monitoring of transmitter modulation. A counter circuit provides digital readout of the deviation of the carrier frequency from its assigned value. The Model 754 is installed on the same rack panel as the Model 753.

1.4 Warranty

TIME & FREQUENCY TECHNOLOGY, INC., warrants each of the instruments of its manufacture to be produced to meet the specifications delivered to the BUYER; and to be free from defects in material and workmanship and will repair or replace, at its expense, for a period of one year from the date of delivery of equipment, any parts which are defective from faulty material or poor workmanship.

Instruments found to be defective during the warranty period shall be returned to the factory with transportation charges prepaid by BUYER. It is expressly agreed that replacement and repair shall be the sole remedy of BUYER with respect to any nonconforming equipment and parts thereof and shall be in lieu of any other remedy available by applicable law. All returns to the factory must be authorized by the SELLER, prior to such returns. Upon examination by the factory, if the instrument is found to be defective, the unit will be repaired and returned to the BUYER, with transportation charges prepaid by SELLER.

Transportation charges for instruments found to be defective within the first thirty (30) days of the warranty period will be paid both ways by the SELLER.

Transportation charges for warranty returns, wherein failure is found not to be the fault of the SELLER, shall be paid both ways by the BUYER.

This warranty does not apply to instruments which, in the opinion of the SELLER, have been altered or misused.

NO OTHER WARRANTY IS EXPRESSED OR IMPLIED. TFT IS NOT LIABLE FOR CONSEQUENTIAL DAMAGES.

1.5 Claim for Damage in Shipment

Your instrument should be inspected and tested as soon as it is received. The instrument is insured for safe delivery. If the instrument is damaged in any way or fails to operate properly, file a claim with the carrier, or if insured separately, with the insurance company.

WE SINCERELY PLEDGE OUR IMMEDIATE AND FULLEST COOPERATION TO ALL USERS OF OUR PRECISION ELECTRONIC INSTRUMENTS.

PLEASE ADVISE US IF WE CAN ASSIST YOU IN ANY MANNER

Time & Frequency Technology, Inc.
3090 Oakmead Village Drive
Santa Clara, CA 95051

(408) 727-7272 TWX 910-338-0584

SECTION 2

INSTALLATION

2.1 Unpacking and Inspection.

Upon receiving the instrument, inspect the packing box and instrument for signs of possible shipping damage. Operate the instrument in accordance with the procedures of Section 3 of this manual. If the instrument is damaged or fails to operate properly, file a claim with the transportation company, or with the insurance company if insured separately.

2.2 Power Requirements.

The Model 753 is factory wired to operate from either a 117-volt or a 230-volt AC source. A marking on the rear panel of the instrument indicates which voltage is to be used. The line frequency must be between 50 and 400 hertz. Maximum power required is 30 watts.

2.3 Installation and Connections.

- a. Mount the instrument in the equipment rack.
- b. Plug the line cord into an appropriate power source (see Section 2.2 above.)
- c. Turn the front-panel CARRIER LEVEL control fully clockwise.

CAUTION

Do not connect the cable to rear panel RF INPUT connector J3 until the CARRIER LEVEL control is turned fully clockwise. Also, make sure the RF input from the transmitter is not more than 10 V RMS before connecting the cable to the RF INPUT connector.

- d. Connect the cable from the high-level modulated sampling point on the transmitter, or from the antenna common point sampling loop, to rear-panel RF INPUT connector J3.
- e. Connect all other rear-panel terminals that are to be used. Refer to Section 3.3.2 for descriptions of the use of the various outputs.
- f. Turn the CARRIER LEVEL control counter clockwise until the CARRIER LEVEL meter indicates at the SET point.

2.4

Field Installation of Options.

All options are easily installed in the field and can be ordered at any time. The Carrier Power Alarm, the Telemetry Lowpass Output, and the Modulation Alarm are installed simply by plugging the printed-circuit board for the desired option into its socket (see Figure 6-1) and then making the required external connections to rear-panel terminal strip J1. These connections are described in Section 3.3.2.

The 10-kHz Whistle Filter is also installed by plugging its printed-circuit board into the appropriate socket. However, before this is done the blank connector with its jumper wire must be removed, and the whistle filter switch installed.

2.5

Model 704E Remote Meter Panel Connections

Connect the 50 foot, six wire cable furnished with the Model 704E to the appropriate terminals of the rear panel terminal strip of the Model 753 Monitor using the colors as shown in Figure 2-1. It is suggested that the +5V green wire be the last connection made. DO NOT SHORT ANY TERMINALS TO THE CHASSIS OR GROUND, AS THIS WILL DAMAGE THE LED'S.

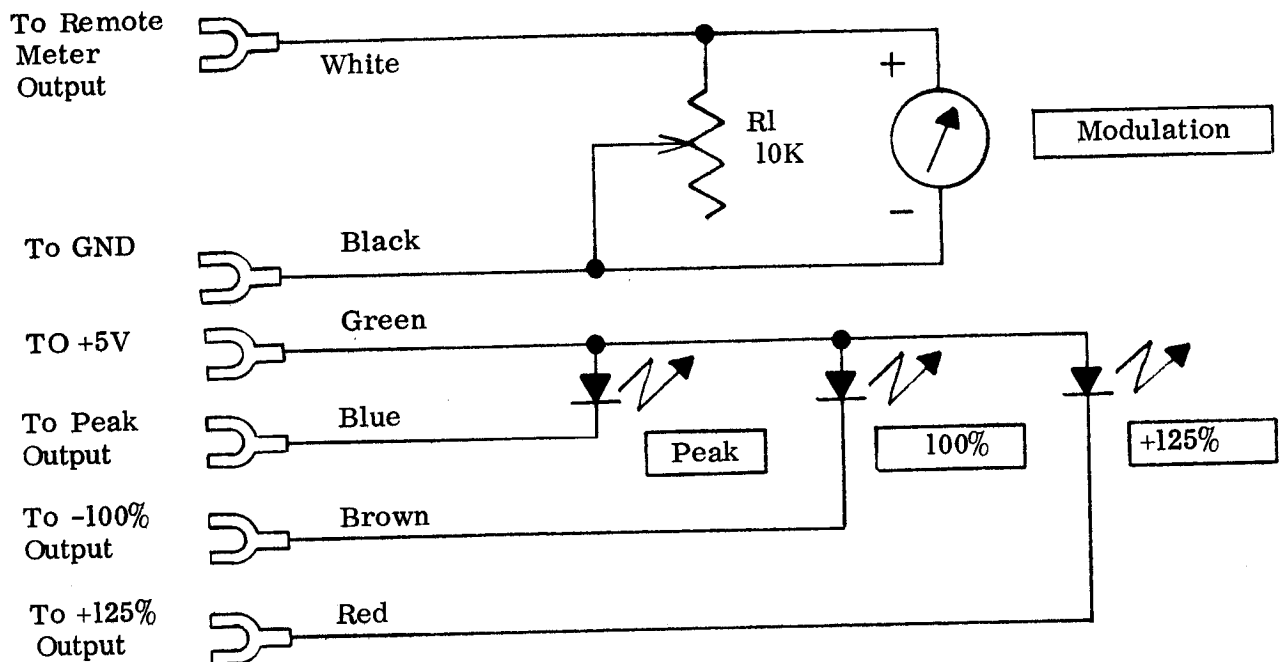

Figure 2-1

SECTION 3
OPERATION

3.1 General.

The Model 753 AM Modulation Monitor displays the modulation percentage of the carrier being monitored. Either positive or negative modulation can be selected for monitoring. Two front-panel lamps provide a flashing indication when the modulation percentage exceeds 125 percent on positive peaks or 100 percent on negative peaks. A third lamp flashes when the modulation percentage exceeds a preset limit; either positive or negative peaks can be selected for this flasher.

The Monitor can also be used to measure residual noise on the carrier and modulation percentage of low-level modulation such as telemetry.

3.2 Turn-On and Warm-Up.

The Monitor contains no on-off switch, and is on whenever it is plugged into an appropriate voltage source. Since the instrument is completely solid-state, a warm-up of no more than 5 minutes is sufficient for it to achieve its rated accuracy.

3.3 Controls, Connectors, and Indicators.

3.3.1 Front Panel.

Fig. 3-1
Ref. No.

	<u>Name</u>	<u>Function</u>
1	CARRIER LEVEL meter and control	Used to adjust the carrier input level from the transmitter as described in Section 2.3. The meter can also be used to observe changes in carrier power during modulation. Although the control is normally adjusted for center-scale meter deflection, the MODULATION meter and flashers will give accurate indications as long as the CARRIER LEVEL meter indicates anywhere between -20% and +20%.
2	PEAK flasher lamp and thumb-wheel switches	The PEAK lamp flashes whenever the transmitter modulation exceeds the percentage for which the thumbwheel switches have been set. The flasher will respond to either positive or negative modulation peaks, depending on whether the MODULATION "-" or "+" switch is depressed.

3.3.1 (Continued)

Fig. 3-1
Ref. No.

<u>Ref. No.</u>	<u>Name</u>	<u>Function</u>
3	-100% flasher lamp	Flashes whenever the transmitter modulation exceeds 99% on negative peaks.
4	+125% flasher lamp	Flashes whenever the transmitter modulation exceeds 125% on positive peaks.
5	METER control	Used in calibrating the MODULATION meter as described in Section 3.4.
6	MODULATION meter	Indicates modulation percentage of carrier being monitored, as described in Section 3.4. The scale to be read depends on which MODULATION METER attenuation switch is depressed, as follows:

<u>MODULATION METER Switch</u>	<u>Applicable Meter Scale</u>
100% (0dB)	Top scale.
30% (-10)	Middle scale.
10% (-20)	Top scale divided by 10.
3% (-30)	Middle scale divided by 10.
1% (-40)	Top scale divided by 100.
0.3% (-50)	Middle scale divided by 100.

The MODULATION meter is also used to indicate residual noise, as described in Section 3.6. Residual noise in dB referenced to 100% modulation is the sum of the reading on the lower meter scale and the dB label on the MODULATION METER switch depressed.

3.3.1 (Continued)

Fig. 3-1
Ref. No.

<u>Ref. No.</u>	<u>Name</u>	<u>Function</u>
7	MODULATION "-" and "+" switches	Select negative or positive modulation peaks, respectively, to operate the MODULATION meter and the PEAK flasher.
8	MODULATION CAL switch	Switches in the built-in modulation calibrator to calibrate the MODULATION meter and the PEAK flasher, as described in Sections 3.4 and 3.5.
9	MODULATION METER attenuation switches	Used with the MODULATION meter to measure percentage modulation and residual noise as described under Reference No. 6 above.

3.3.2 Rear Panel

Fig. 3-2
Ref. No.

<u>Ref. No.</u>	<u>Name</u>	<u>Function</u>
1	117VAC line cord	For connecting the Monitor to a power source. If the Monitor is wired for a 230V input, the line cord will be so marked.
2	1/4A SLO BLO fuse	Fuses the AC power circuit.
3	BALANCED AUDIO terminal strip	When the Balanced Audio Monitor Output option is selected, this strip provides a 600 ohm balanced audio output at 0 dBm.
4	AUDIO OUTPUT connector J2	Provides an audio output of 5V RMS into 5000 ohms for driving a distortion analyzer, oscilloscope, etc.
5	RF INPUT connector J3	Provides a means for introducing the transmitter carrier through a 50-ohm cable. Maximum voltage is 10 V RMS.
6	WHISTLE FILTER switch	When the 10-kHz Whistle Filter option is selected, this switch provides a means of placing the filter in or out of the audio output lines.
7	Terminal strip J1	Provides the following outputs: CARRIER ALARM -- This terminal sinks a maximum +30 V DC, 50 ma load to ground when the RF input drops below the level necessary to operate the Monitor. It is also used for the Carrier Power Alarm output when that option is installed.

3.3.2 (Continued)

Fig. 3-2
Ref. No.

Name

Function

7

Terminal strip J1

TELEMETRY OUTPUT-- When this option is selected, an audio output is delivered to this terminal through a 35-Hz low-pass filter to drive subaudible telemetry equipment.

MODULATION ALARM--When this option is selected, this terminal sinks a maximum +30 V DC, 50 mA load to ground when the modulation drops below 10% for a period of time which can be preset from 2 to 30 seconds.

AUDIO MONITOR OUTPUT--a 600 ohm unbalanced audio output at 0 dBm for driving a studio audio system, etc.

REMOTE METER PANEL--When a Model 704E Remote Readout Panel is used with the Model 753, these six terminals connect to corresponding terminals on the Model 704E to provide meter and flasher lamp drive.

3.4 Measurement of Modulation Using MODULATION Meter.

The MODULATION Meter is used by simply pushing either the MODULATION "+" or "-" switch on the front panel. The meter gives a quasi-peak indication of either positive or negative peak modulation depending upon front-panel selection. For maximum accuracy, the MODULATION meter calibration should be checked regularly and adjusted if necessary. The meter is calibrated by depressing the MODULATION CAL and the MODULATION METER 100% pushbuttons; if the meter reading is not exactly 100% with the MODULATION "-" button depressed or 125% with the MODULATION "+" button depressed, adjust the METER control (through a hole in the front panel) until it is.

3.5 Measurement of Modulation Using Peak Indicators.

The peak flashers are intended to catch fast transients and peaks that the meter cannot respond to. The -100% and +125% flashers operate regardless of the settings of other front-panel switches, and indicate when the modulation peaks exceed -99% and +125%, respectively.

To use the PEAK flashers, set the thumbwheel switches to the desired modulation percentage and depress either the MODULATION "-" or "+" button. The PEAK flasher will then indicate when the modulation exceeds the preset value in the selected direction.

Accuracy of the peak flashers should be checked regularly, as follows. Depress the MODULATION CAL button; the -100% and +125% flashers should light regardless of the thumbwheel settings and regardless of whether the MODULATION "-" or "+" switch is depressed. If the flashers do not light, refer to Section 5.8 for corrective maintenance.

With the MODULATION CAL and "-" switches depressed and the thumbwheel switches reading 100 the peak flasher should be on, at 101% it should be off; if it does not, refer to Section 5.5.3.

3.6

Measurement of Residual Noise.

Residual noise on the transmitter carrier of up to 40 kHz can be read to an accuracy of 1 dB, and noise of up to 70 kHz can be read to 2 dB. Thus residual sideband measurements can be made on transmitters using newer modulated techniques that might produce unwanted high-frequency spurs.

To read residual noise, turn off the transmitter modulation. Starting with the 0 dB MODULATION METER switch, depress each switch in turn until a reading is obtained on the MODULATION meter. The residual noise in dB below 100% modulation is the algebraic sum of the lower-scale meter reading and the value of the MODULATION METER switch depressed. Residual noise measurements should be made with monitor reading positive peaks.

An alternative method of measuring residual noise that does not require turning off transmitter modulation is to depress the MODULATION METER switch that has been found to give a suitable meter reading for the expected value of residual noise. Although the meter will read off-scale during normal modulation, it will not be damaged; and residual noise can be read on the meter during lulls in the program.

3.7

Distortion Measurements.

Connect the distortion analyzer input to the rear-panel 5 V RMS AUDIO OUTPUT connector, and tune the analyzer to the fundamental frequency of the audio used to modulate the transmitter. Residual distortion in the Monitor is typically 0.15 percent at 99 percent modulation.

3.8

Use of the Model 704E Remote Readout Panel.

The Model 704E duplicates the indications of the Model 753 front-panel MODULATION meter and peak flashers. Terminals on the Model 704E are connected through a six-wire cable to corresponding terminals on strip J1 on the rear panel of the Model 753.

3.9

External Peak Counter .

External counting circuits can be connected to any of the remote flasher outputs. Figure 3-3 shows the recommended interface circuit for connecting these counters.

3.10 10-kHz Whistle Filter (Optional).

When this option is installed, it can be used to eliminate the tone produced by a carrier 10 kHz away from that of the transmitter being monitored. The filter is in the audio outputs only, and has no effect on operation of the modulation meter or the peak flashers.

To use the whistle filter, place the rear-panel WHISTLE FILTER switch in the IN position. For audio distortion measurements, oscilloscope observation of waveforms, etc., the switch should be in the OUT position.

3.11 Telemetry Lowpass Output (Optional.)

In this output, all frequencies above 35 Hz are removed for the purpose of driving telemetry equipment operating on subaudible frequencies. There are no controls on the Model 753 for this option; it is necessary only to connect the external telemetry equipment to the rear-panel TELEMETRY OUTPUT and GND terminals.

3.12 Carrier Power Alarm (Optional.)

Without this option, the rear-panel CARRIER ALARM terminal shorts to ground when the monitored carrier drops below the level necessary to operate the Monitor. When the Carrier Power Alarm option is installed, the CARRIER ALARM terminal additionally shorts to ground when the carrier level drops below a preset level. The lower level is internally adjustable between 0% and 20% below normal level, and is factory set at 10% below normal. The upper level is internally adjustable between 0% and 20% above normal level, and is factory set at 5% above normal. If these threshold levels are to be changed, refer to Section 5.5.6. There are no front-panel controls for this option.

It is emphasized that the CARRIER ALARM terminal is an open-collector output; the voltage at the terminal must not exceed +30 volts and the current through the terminal must not exceed 50 milliamperes.

3.13 Modulation Alarm (Optional.)

When this option is installed, the rear-panel MODULATION ALARM terminal shorts to ground when the modulation on the monitored carrier drops below 10% for a preset period of time. This period is internally adjustable between 2 and 30 seconds (see Section 5.6.11.) There are no front-panel controls for this option.

The MODULATION ALARM terminal is an open-collector output; the voltage at this terminal must not exceed +30 volts, and the current through the terminal must not exceed 50 milliamperes.

3.14 Balanced Audio Output (Optional.)

This circuit provides a 600-ohm balanced output at 0 dBm. There are no controls for this option.

(a) High impedance loads such as counters may be driven directly.

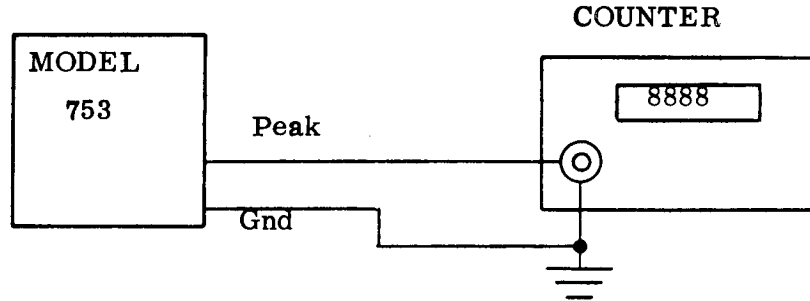

(b) Light loads (LED's, small relays)

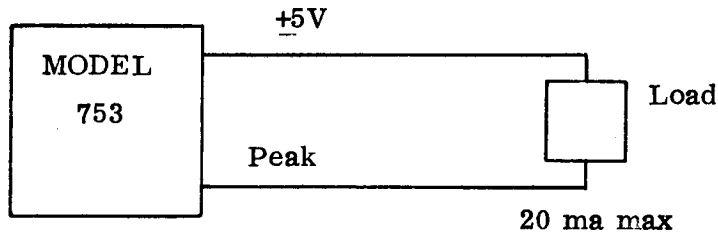

(c) Heavy loads

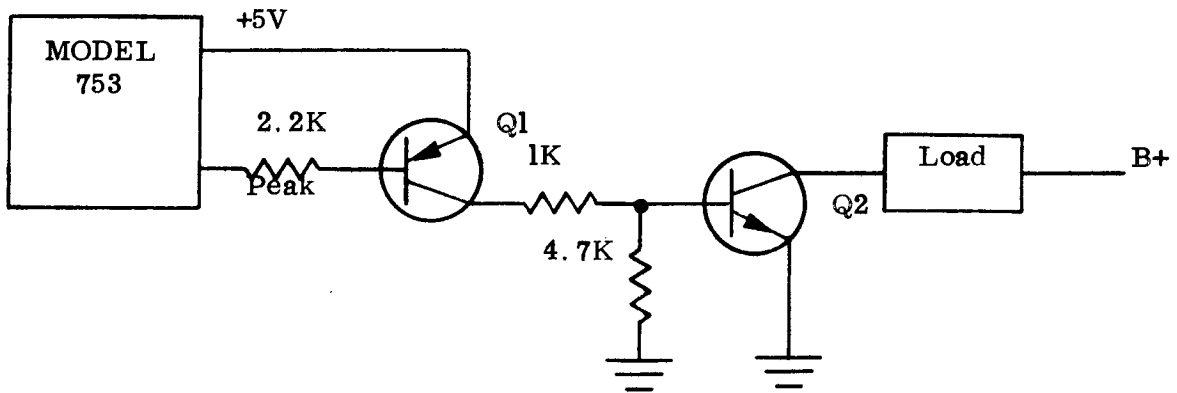

Q1 = General purpose PNP transistor such as 2N3644

Q2 = NPN transistor to handle current and voltage requirements of load being driven. Approximately 3ma of base current is supplied to Q2 using this circuit.

FIG. 3 - 3
MODEL 753
Recommended Circuits for
driving external loads on
flasher outputs.

SECTION 4

THEORY OF OPERATION

4.1 Block Diagram Discussion (Figure 6-1)

The modulated carrier to be monitored is brought in through the RF INPUT connector and is adjusted by means of the CARRIER LEVEL potentiometer to 1 V RMS at the input to the AM detector; this corresponds to the CARRIER LEVEL meter indicating at the SET mark. The AM detector is a full-wave rectifier which balances out the carrier frequency. This provides a wider bandwidth through the lowpass filter to the metering circuit without allowing the carrier to be passed.

The output of the AM detector is a DC voltage, which is proportional to the input carrier level, and the audio modulation riding on the DC. This composite signal is fed through the linear phase lowpass filter which eliminates the carrier and its harmonics and does not produce overshoot on square-wave audio and complex music waveforms. The DC out of the filter is amplified to drive the CARRIER LEVEL meter. This circuit is factory adjusted so that a 1-volt RMS input to the AM detector produces a midscale (SET) reading on the CARRIER LEVEL meter. The amplified DC is also used to actuate an external carrier alarm by turning on the carrier fail transistor when the DC level out of the lowpass filter drops below -20% on the carrier level meter.

The audio out of the lowpass filter is applied to a voltage-controlled attenuator to keep the modulation meter and flasher calibrated regardless of the CARRIER LEVEL meter reading. The attenuator is in a loop with a buffer amplifier and comparator. The buffered DC voltage out of the attenuator is compared with a reference DC voltage, and any difference is applied to the attenuator to correct its DC output. Holding the DC level constant maintains the calibration of the meter and flasher circuits.

The audio output from the buffer amplifier is fed to the "+" terminal of the MODULATION switch to measure positive modulation peaks, and it is also inverted and applied to the "-" terminal of the MODULATION switch to measure negative modulation peaks. Either of these can be selected by the MODULATION switch for driving the MODULATION meter through the meter amplifier, attenuator circuit, and meter detector. The adjustable attenuator makes it possible to read audio voltages down to 70 dB below 100% modulation, for measurement of residual noise and hum without an external voltmeter.

The selected positive or negative modulation is also applied to the programmable peak detector. When the front-panel thumbwheel switches are set to 100%, they furnish a DC voltage to the peak detector which is just twice the average DC voltage out of the buffer amplifier; these voltages are compared in the peak detector and when the audio peaks reach twice the average value for 100% modulation, the peak detector triggers a one-shot which turns on the PEAK LED for approximately 2 seconds. Other settings of the thumbwheel switches produce voltages to cause the PEAK lamp to flash at the percentage modulation indicated by the switches.

4.1

(Continued)

When the MODULATION switch is turned to the "-" position, the inverted modulation waveform is applied to the peak detector to cause the PEAK lamp to flash when negative modulation peaks exceed the value for which the thumbwheel switches are set. The thumbwheel switches can be set for any modulation percentage between 0% and 199%. Accuracy is specified to be within $\pm 2\%$ from 30% to 150%; it is typically $\pm 2\%$ from 0% to 199%.

The noninverted output of the buffer amplifier is also applied to the +125% detector and the -100% detector. These function in the same way as the programmable peak detector, except that the reference voltage is not adjustable by an external control. The -100% detector is factory set to cause its LED to flash when the modulation negative peaks exceed 99%, and is internally adjustable to flash from 90% to 100%. The +125% detector is factory set for 125% on positive peaks, and is internally adjustable from 115% to 125%. Both of these detectors are followed by pulse stretchers to cause the LED to remain lighted for at least 2 seconds.

The audio from the buffer amplifier is amplified and fed to two standard audio outputs; one (AUDIO OUTPUT) is 5 volts RMS into 5000 ohms and the other (AUDIO MONITOR OUTPUT) is 0 dBm into 600 ohms.

The calibration circuit consists of a 500 kHz oscillator which simulates a carrier. Modulation of -100% and +125% is digitally generated, and the modulated carrier is fed into the AM detector when the front-panel MODULATION CAL switch is depressed. Since the modulation percentage of the calibration signal is precisely determined by digital circuitry and is independent of the carrier level and carrier frequency, the MODULATION meter and the peak flashers can be calibrated regardless of the reading on the CARRIER LEVEL meter.

4.2 AM Detector, Lowpass Filter, and Summing Amplifier (Figure 6-3)

The detector circuit consists of input transformer T1 and diodes CR1 and CR2 in a full-wave rectifier circuit. The diodes are biased to reduce distortion which may occur when modulation approaches 100%. This bias is factory adjusted by means of potentiometer R85, and should not be readjusted in the field unless an AM Modulator is available with distortion less than 0.1% at 99% modulation.

Z18, Z17, and associated components constitute an active, linear phase, Gaussian, lowpass filter. The 3-dB cutoff is at 80 kHz, making it possible to measure all sidebands out to 70 or 80 kHz. The bias on the AM detector diodes adds a DC component to the audio out of the lowpass filter that is not due to the carrier level. To compensate for this, the same bias that is applied to the detector diodes is also applied to diodes CR6 and CR7. Thus the common-mode input of Z16 has the same value as that at the inverting input of Z16; and the DC level out of Z16 is proportional to carrier level only. Riding on this DC level is an AC voltage proportional to the modulation on the carrier.

4.3 Audio Attenuator (Figure 6-3)

The composite signal out of summing amplifier Z16 drives voltage follower Z11 through the voltage divider network consisting of R54, the photo-resistor in optical coupler Z12, and R52. Lowpass filter R50/C16 passes only the DC component of the composite signal to the noninverting input of comparator Z15. When this DC voltage is different from the reference voltage set by R48, Z15 produces an output which is applied to emitter follower Q9. Current change through the LED of Z12 changes the resistance of Z12 to apply a change in Z11 input voltage which will restore the DC output of Z11 to its original value. This action ensures that the modulation amplitudes to be measured will not be affected by changes in the level of the carrier fed into the Monitor.

The level-stabilized composite signal from voltage follower Z11 is routed to the +125% and -100% peak flasher circuits, and to the "+" terminal of the front panel MODULATION switch. The Z11 output is also inverted by Z13 and is fed to the "-" terminal of the MODULATION switch. The selected signal polarity is used to drive the MODULATION meter through the MODULATION METER attenuator and meter amplifier, and also to drive the programmable PEAK flasher.

4.4 Carrier Level Meter Driver (Figure 6-3)

Operational amplifier Z27 converts the DC voltage component of the composite signal from summing amplifier Z16 to a current to drive the CARRIER LEVEL meter. An offset voltage provided by potentiometer R44 allows the meter to be set to midscale for a 1-volt RMS carrier at the input of the AM detector. The output of Z27 also drives carrier fail transistor Q11. With a carrier present, the negative output of Z27 keeps Q11 turned off. In event of carrier failure, the output of Z27 goes positive, causing Q11 to provide a low-resistance path to ground for an external alarm circuit.

4.5 Audio Amplifier (Figure 6-3)

When the Whistle Filter option is not installed, the composite signal from inverting amplifier Z13 is fed through a jumper bypassing the switch to the inverting input of audio amplifier Z14. If the Whistle Filter is installed, it can be inserted in or removed from the circuit between Z13 and Z14 by switch S2. Z14 amplifies the audio modulation to 5 volts RMS for operating external equipment connected to the rear-panel AUDIO OUTPUT connector. This output is also attenuated to 0 dBm by R34 and R35 for supplying the AUDIO MONITOR OUTPUT, and is fed unattenuated to the MODULATION ALARM and TELEMETRY LOWPASS terminals for operation of optional equipment.

4.6 Modulation Meter Amplifier (Figure 6-3)

The level-stabilized composite signal from Z11, either noninverted or inverted depending on whether the "+" or "-" MODULATION switch is depressed, is fed through attenuator R76-R82 to the meter amplifier, consisting of operational amplifiers Z19 through Z21. The output of this amplifier is rectified by meter detector CR8 to drive the modulation meter through operational amplifier Z22, which acts as a buffer and current driver. C20 and R61, together with the meter characteristics, determine the meter fall time, which is between 500 and 800 milliseconds. Meter deflection, rise time, and overshoot are determined by C19, R59, and R60. The values of these components are factory selected for a rise time to 90% of 40 to 90 milliseconds, and an overshoot of less than 7%.

4.6 (Continued)

With the MODULATION CAL switch and the MODULATION METER 100% switches depressed, the gain of amplifier Z21 is adjusted by R63 to give a modulation meter reading of 100% when the MODULATION "-" switch is depressed, or 125% when the MODULATION "+" switch is depressed.

4.7 Peak Flashers (Figure 6-3)

Input for the +125% flasher is the level-stabilized composite signal from Z11. This is applied to the noninverting input of comparator Z5. When a modulation peak exceeds the voltage to which calibrating potentiometer R13 is set, a positive pulse is produced at the output of Z5. R13 is normally set to produce an output when positive modulation peaks reach or exceed 125%. Gates Z9-3 and Z9-14 constitute a one-shot multivibrator, which acts as a pulse stretcher to lengthen the pulse period to approximately 2 seconds. Transistor Q6 drives the front-panel +125% LED flasher, and also provides an open-collector output for a remote flasher.

Circuitry for the -100% flasher is the same as that described in the preceding paragraph, except that Z6 is connected as an inverting amplifier so that negative modulation peaks are measured. Threshold is adjusted by R15, which is normally set to give an output when negative peaks reach or exceed 99%.

Input to the programmable peak flasher circuit comes from the MODULATION "+" or "-" switch, which selects either the noninverted composite signal from Z11 or the inverted composite signal from Z13, respectively. The selected signal is compared in Z7 with a reference voltage supplied by peak flasher reference amplifier Z26. Z26 is an operational amplifier with a fixed DC input from 48; its gain is controlled by a resistance value selected by the front-panel thumbwheel switches. The thumbwheel switches are calibrated so that when they indicate 100%, the selected resistance is of such a value that the DC voltage out of Z26 is exactly twice the DC level produced by the unmodulated carrier. Other settings of the thumbwheel switches select appropriate resistance values to produce the required reference voltage out of Z26.

The reference voltage from Z26 is compared in Z7 with the selected modulation; when the modulation amplitude exceeds the reference voltage, Z7 produces an output pulse. The pulse is stretched to approximately 2 seconds in Z10-2/Z10-4 to drive the front-panel PEAK LED flasher through Q8. Driver Q8 also furnishes an open-collector output to the rear panel for a remote indicator.

The gain of Z26, and hence the reference voltage, can be adjusted in the calibrate mode by means of R103.

4.8 Calibration Signal Generator (Figure 6-3)

The purpose of the calibration signal generator is to produce a signal that simulates an RF carrier precisely modulated 125% positively and 100% negatively. Q4 and Q5 form a 1-MHz free-running multivibrator. Flip-flop Z2-11 divides the frequency by 2 to give a 500-kHz input to pin 2 of NAND gate Z1. The circuitry consisting of divider chain Z4/Z3, gate Z8, and flip-flop Z2-15, driven by the 500-kHz output of Z2-11, produces an asymmetrical output. This output is applied to pin 1 of Z1; thus the gated output at pin 3 of Z1 is a 500-kHz signal gated alternately on and off. This provides the required +125%, -100% modulation calibration accuracy is not dependent on accuracy of the oscillator frequency, but only on the accuracy of the digital divider circuit that generates the asymmetrical waveform.

4.8

(Continued)

The output of Z1-3 is amplified to approximately 1 volt RMS by the push-pull circuit consisting of Q1, Q2, Q3, and T2. When the MODULATION CAL switch is depressed, this calibration signal replaces the monitored signal as the input to the AM detector.

4.9

Power Supplies (Figure 6-3)

The 26-volt center-tapped secondary of the power transformer is connected to two full-wave rectifiers. One (CR11/CR12) supplies a positive output to regulator Z24, which provides a +12 volt output, and to regulator Z23, which provides +5 volt output. There are no adjustments on the power supplies.

CR-9 and CR-10 supplies a negative output to regulator Z25, which provides a -12 V output.

The 26-volt output from the transformer also furnishes current for the two 12-volt modulation meter lamps, connected in series with a 22 ohm dropping resistor.

SECTION 5

MAINTENANCE

5.1 General.

Since the Model 753 is an all solid-state instrument very little maintenance should be required. The Model 753 should be installed sufficiently far away from high-heat producing instruments to insure an ambient operating temperature below +50°C (+122°F). Access to the unit is via the top panel which is held in by six sheetmetal screws. The printed circuit board is removed by following steps 1-5 below. Re-assembly is by reverse order. 1) Remove top cover; six sheetmetal screws. 2) Remove the front panel assembly; two #6-32 screws and nuts, and disconnect cable plugs from the p.c. board. 3) Remove two #4-40 screws and nuts from the rear-panel 10 position terminal strip. 4) Remove the board from the hold-downs by lifting the board and squeezing the locking ears on the hold-downs. 5) Tilt the p.c. board sideways and remove the front panel cut-out.

5.2 Periodic Maintenance.

The only periodic maintenance that should be required is to remove excess dust accumulation on an annual basis. This is done by removing the six sheetmetal screws holding the top cover, and blowing the dust out with compressed air.

5.3 Field Installation of Options.

5.3.1 Telemetry Lowpass.

This option is installed by plugging the p.c. mounted connector of the telemetry lowpass board onto the mating connector J4 on the 753 main p.c. board. J4 is marked "TELEMETRY LOWPASS".

5.3.2 Modulation Alarm.

This option is installed by plugging the p.c. mounted connector of the modulation alarm board onto the mating connector J3 on the 753 main p.c. board. J3 is marked "MODULATION ALARM".

5.3.3 Carrier Power Alarm.

This option is installed by plugging the p.c. mounted connector of the carrier power alarm board onto the mating connector J5. J5 is marked "CARRIER POWER".

5.3.4 Balanced Audio Output.

To install the balance audio output option, the main p.c. board must be removed from the chassis. Refer to section 5.1 for instructions. After the p.c. board has been removed from the chassis, mount the audio transformer, R31, R32, and J13 as shown in figure 2-2. Re-install the p.c. board and connect the wiring to J13 and install the three connectors provided to the rear panel.

5.3.5 10 kHz Whistle Filter.

To install the 10 kHz whistle filter option the main p.c. board must be removed from the chassis to install the whistle filter switch as shown in figure 2-2. The wire jumper should first be removed from the holes in the p.c. board where the switch is to be inserted. Replace the p.c. board in the chassis and plug the p.c. mounted connector on the 10 kHz whistle filter board onto its mating connector on the main p.c. board J12. J12 is marked "WHISTLE FILTER".

5.4 Changing Meter Lamps.

Access to the meter lamps is through the top panel after removing the six sheetmetal screws securing the top panel.

5.5. Calibration Procedures.

The following calibration procedures are intended for the person having a R. F. generator capable of very low distortion amplitude modulation and whose level can be accurately controlled. A high input impedance digital voltmeter and an oscilloscope are also necessary.

5.5.1 Audio Attenuator Circuit.

Connect the input of a digital voltmeter to TP-5, the wiper of R48 and adjust R48 for 0.500 VDC. Connect a 1V RMS R. F. signal at the desired frequency to the R. F. input and turn the R. F. level control to the full Counter-Clockwise position. Measure the D. C. Voltage at TP-6, pin 6 of Z16, it should be 1.2 Volts \pm 0.1 Volts. This voltage will not be correct if 1.0 V RMS is not accurate. This voltage is not critical if it is between 1.0 and 1.5 VDC. Measure the D. C. voltage at pin 6 of Z11, it should be 0.500 V \pm 0.010 Volts D. C. Changing the R. F. input by \pm 3dB will temporarily change this voltage but it should return to 0.500V within 5 seconds. If this occurs the audio attenuator circuitry is working properly.

5.5.2 Carrier Level Meter Circuit.

With a 1V RMS R. F. Carrier present at the input to the Model 753, adjust R44, CARR LEVEL so that the carrier level meter reads on the SET mark.

5.5.3 Peak Flashers.

Amplitude modulate the R. F. generator using a 400Hz audio signal so that the carrier is just at cut-off on the negative modulation peaks (-100%). Set the thumbwheel switches on the model 753 to 100% and press the "-" button, the "PEAK" indicator should be "ON" and "OFF" at 101%. Adjust R103 "PEAK CAL" for proper operation. Reduce the modulation to 99%, the -100% flasher should be "ON", reduce the modulation to 98% and the -100% flasher should be "OFF". Adjust R15 (-100%) for proper operation. Depress the "CAL" button, the "PEAK", "-100%", and "+125%" indicators should be "ON". Slowly vary R13 (+125%) to make sure the "+125%" flasher is just coming "ON".

5.5.4 Modulation Meter.

Amplitude modulate the R. F. generator to 100% with a 400 Hz audio signal. The modulation meter on the 753 should read 100% with the 0 dB (100%) attenuator button depressed. Adjust the METER Cal control if necessary. Depress the "CAL" and "-" buttons on the 753 front panel, the Modulation meter should read 100% $\pm 1\%$. Depress the "+" switch, and the meter should read +125% $\pm 2\%$.

5.5.5. 10 kHz Whistle Filter.

Modulate the R. F. carrier to 90% using a 10 kHz audio signal. Connect an audio voltmeter to any of the audio outputs on the rear panel of the 753. With the whistle filter switch in the "IN" position the audio output level should drop at least 40 dB below the level obtained with the switch in the "OUT" position. If not, adjust the three trimmer capacitors on the whistle filter board for maximum rejection of the 10 kHz. NOTE: If the audio generator distortion, or the audio distortion introduced by the modulator in the R. F. generator is greater than 1%, this 40dB figure will not be obtainable because of the high level of harmonics coming through the audio. The 10 kHz filter does not reject the harmonics of 10 kHz.

5.5.6 Carrier Power Alarm.

With the carrier level meter at the "SET" mark the carrier level meter should be "OFF" or open. Increase the R. F. level 5% or decrease the R. F. level 10% and the output should be "ON" or shorted. R5 on the carrier power board adjust for the $\pm 5\%$, and R4 adjust for the -10%.

5.5.7 Modulation Alarm.

With 5% modulation or less the modulation alarm output should be "ON" or shorted. With 15% or greater modulation, the output should be "OFF" or open. R10 on the modulation alarm board adjust the delay between loss of modulation, and the alarm going "ON".

5.6.1 Nothing works

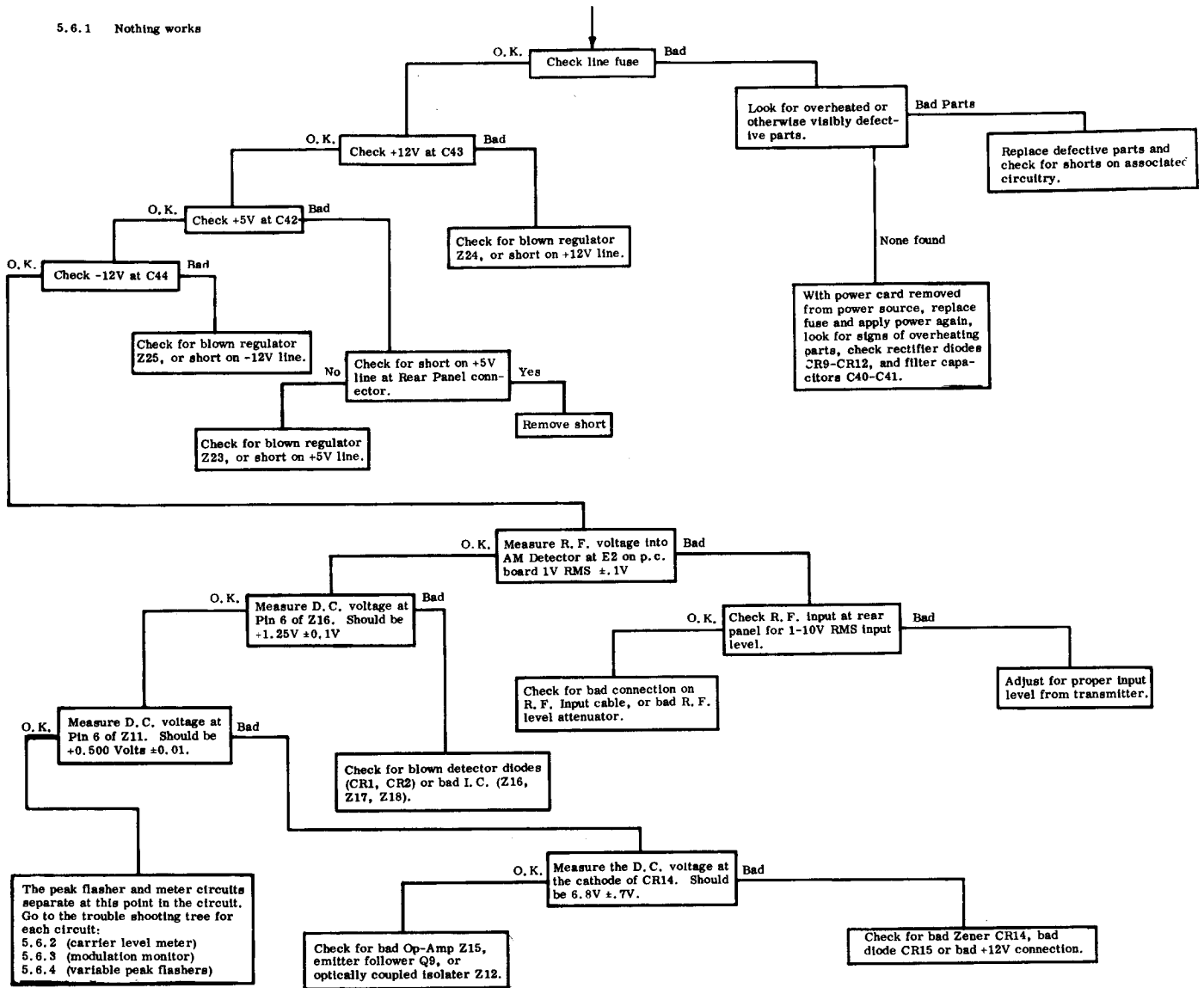

5.6.2 Carrier level meter does not work

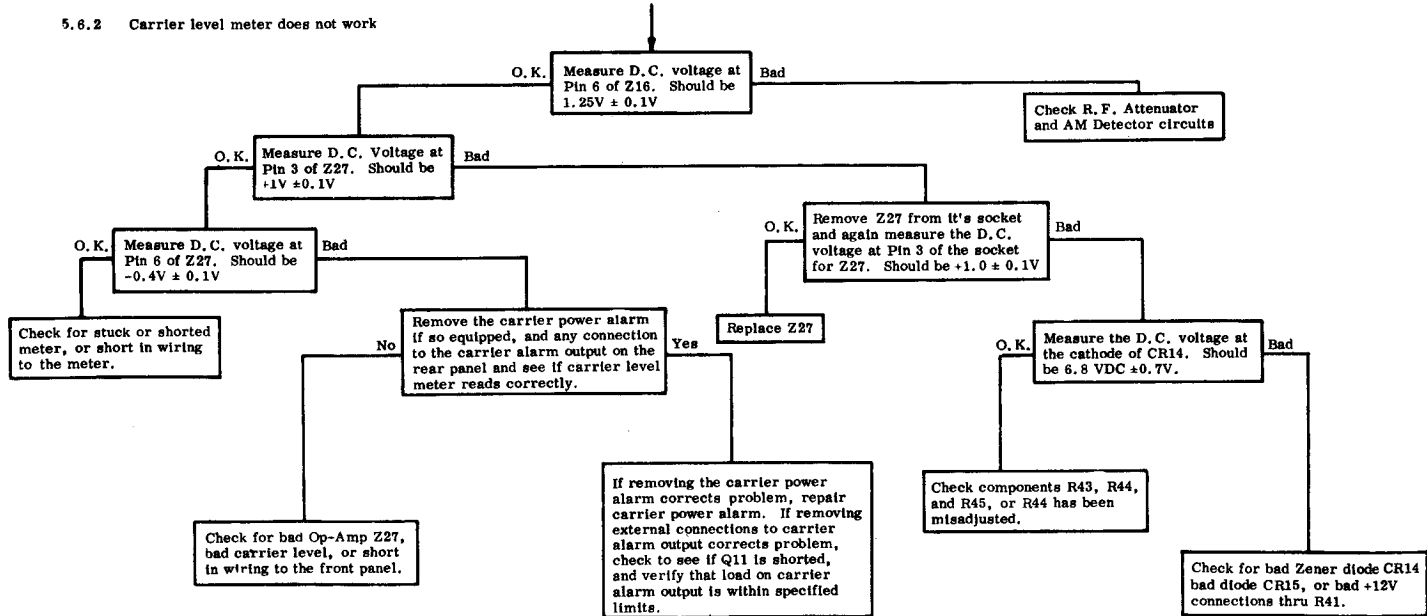

5.6.3 Modulation meter does not work

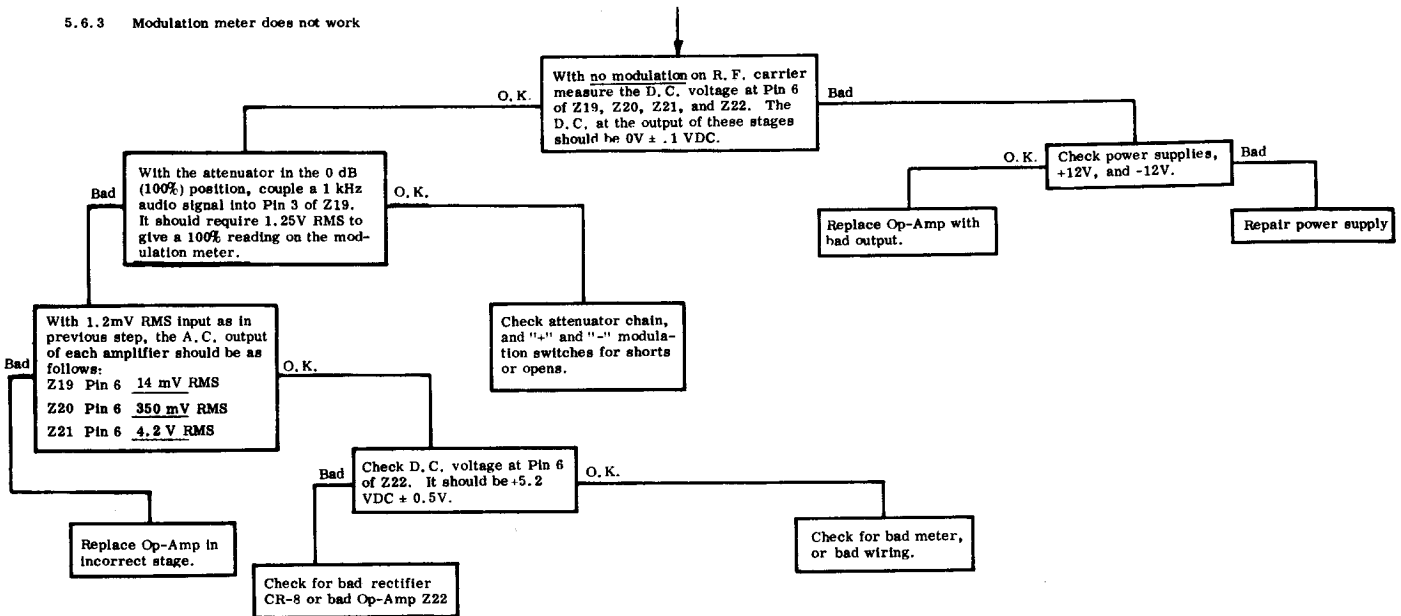

5.6.4 Variable Peak Flasher does not work

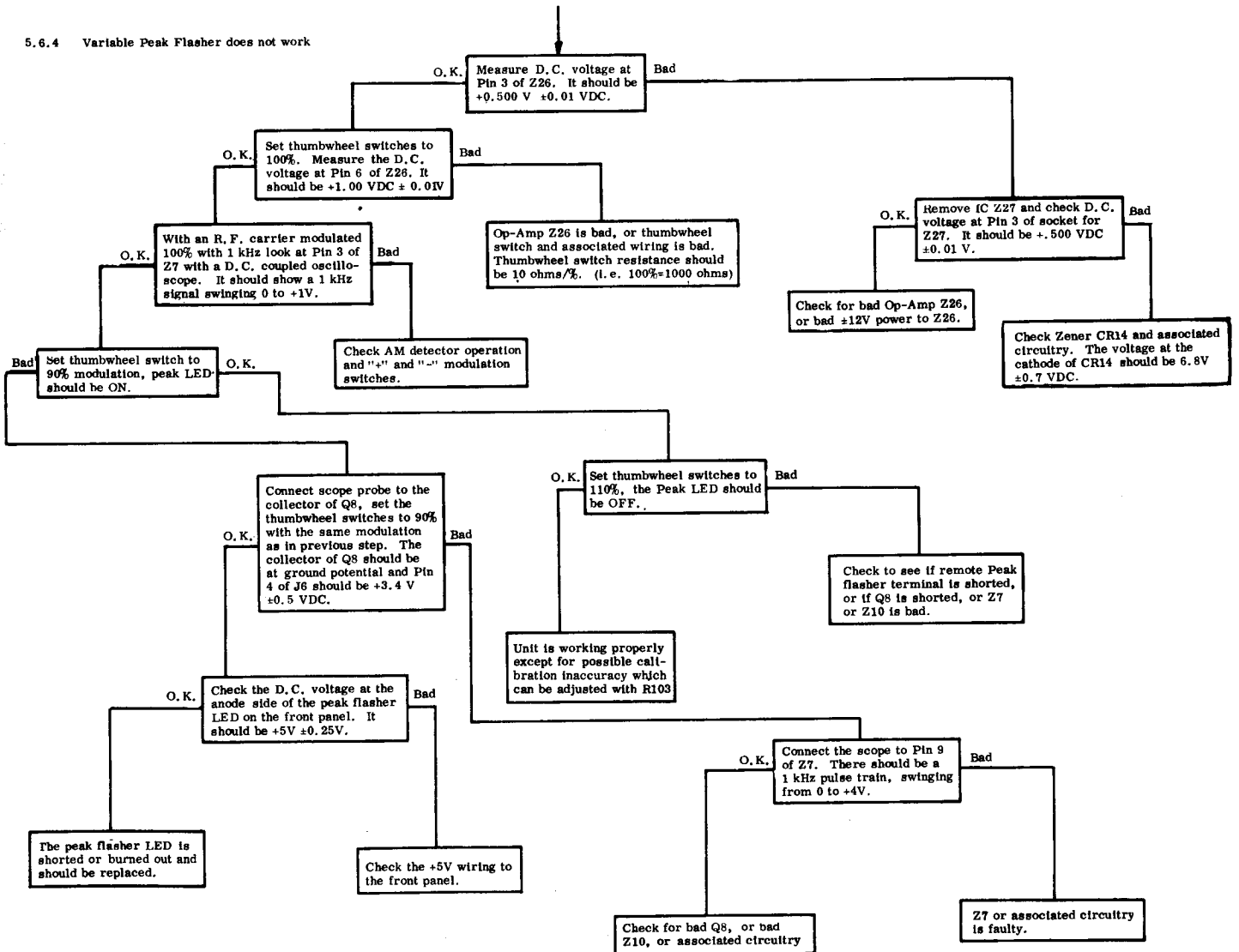

5.6.5 -100% or +125% Flasher does not work

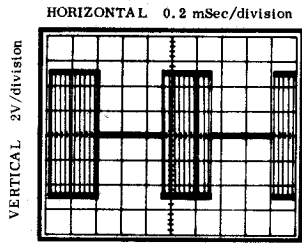
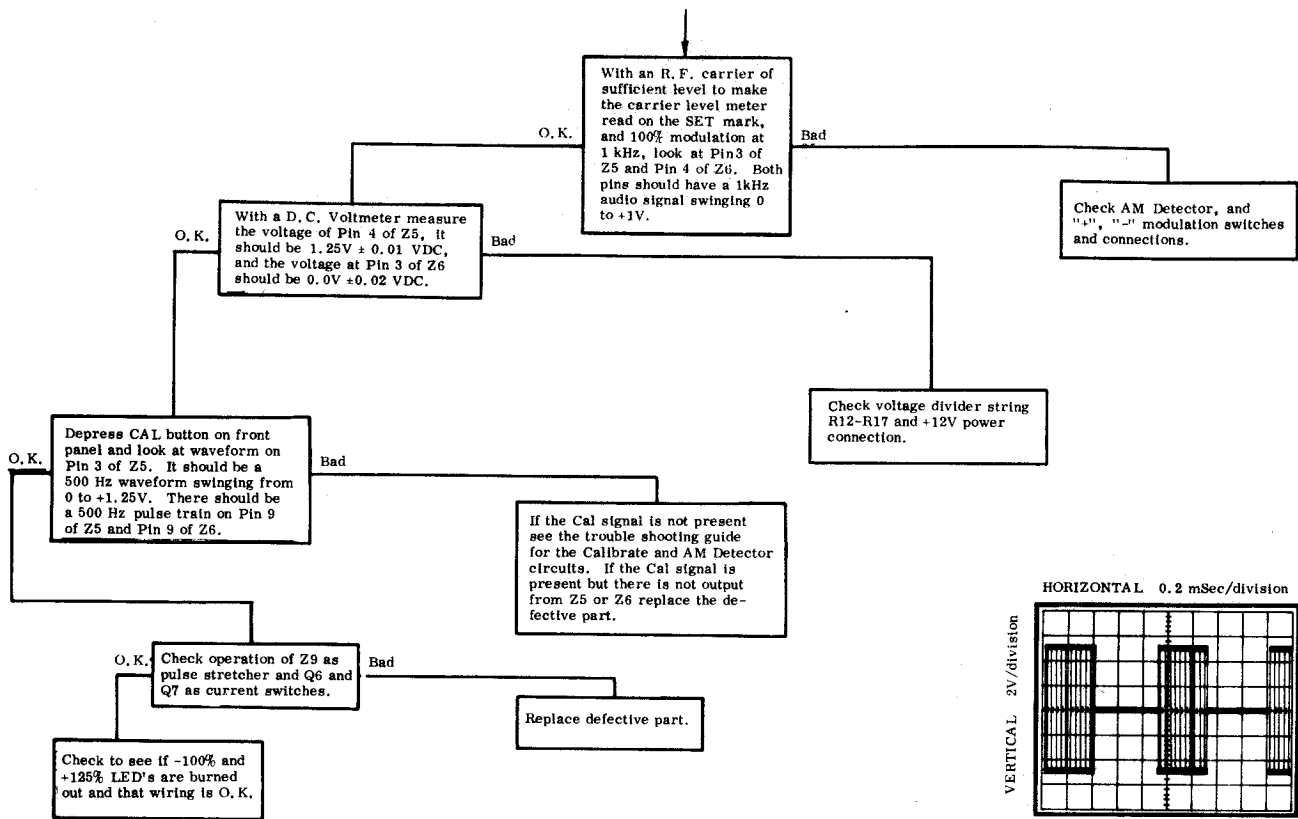
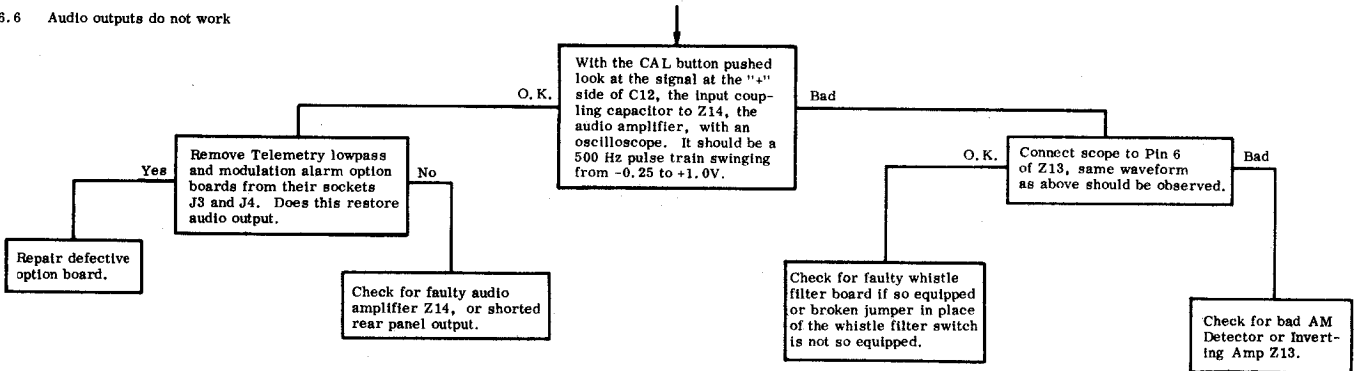
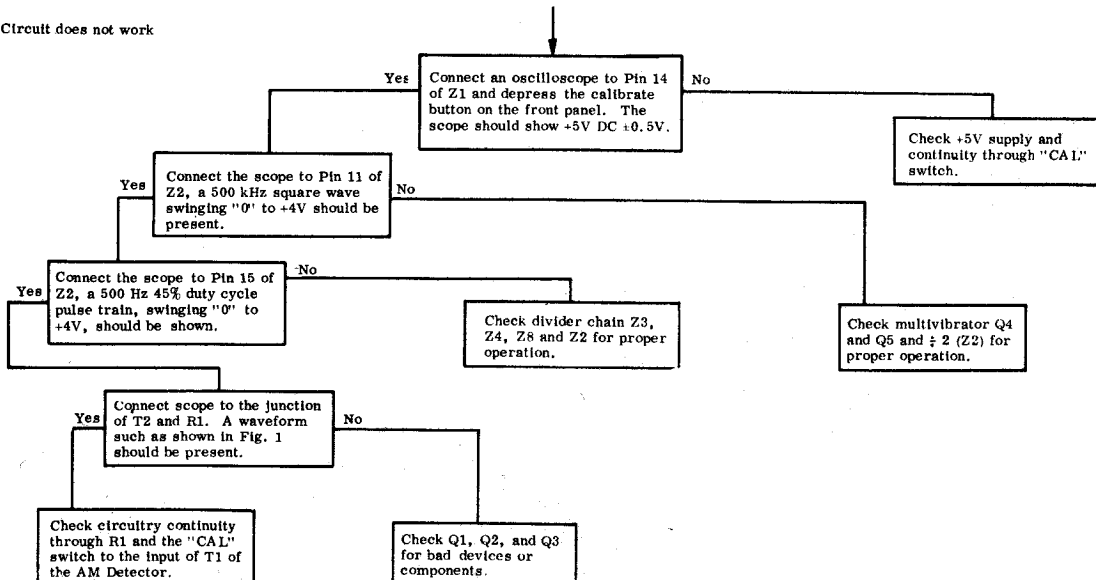

Figure 1

5.6.6 Audio outputs do not work



5.6.7 Calibrate Circuit does not work



5.6.8 Telemetry Lowpass does not work

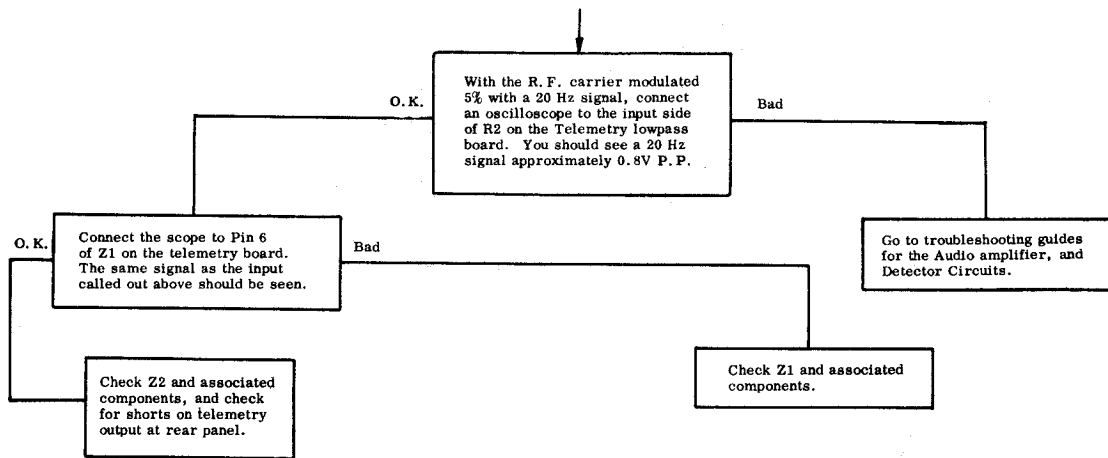

5.6.9 10 kHz Whistle Filter does not work

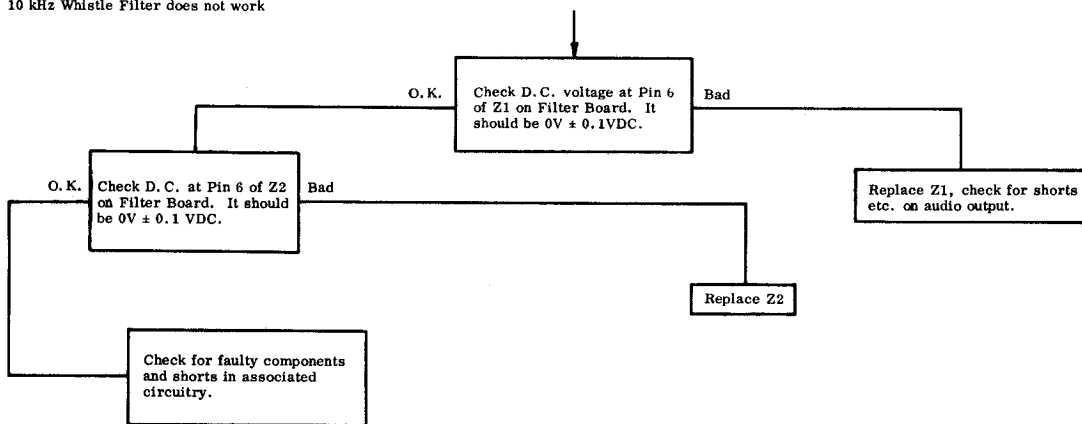

5.6.10 The Carrier Power Alarm does not work

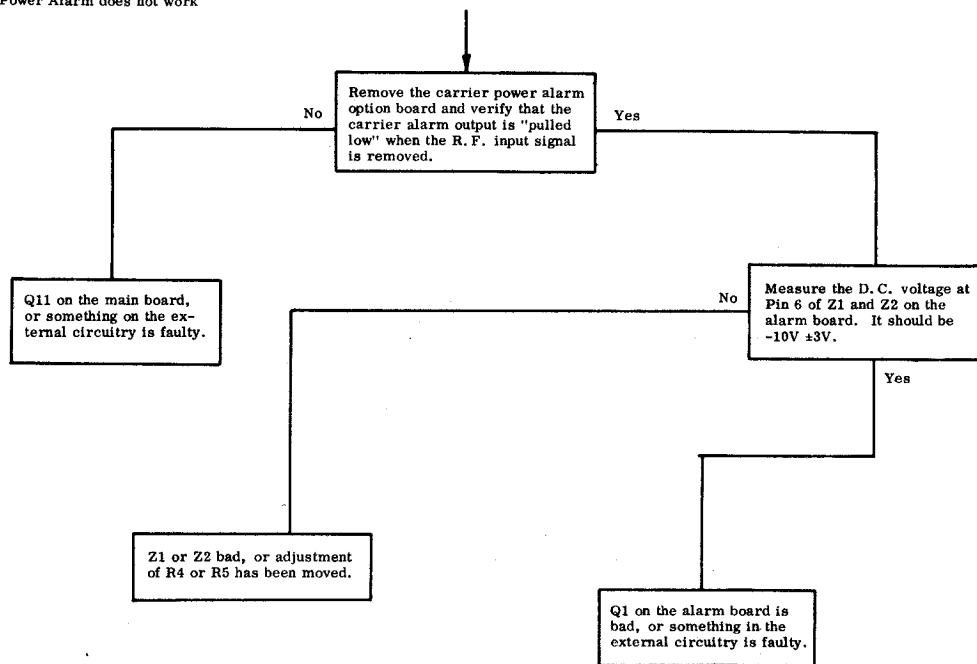

5.6.11 Modulation alarm does not work

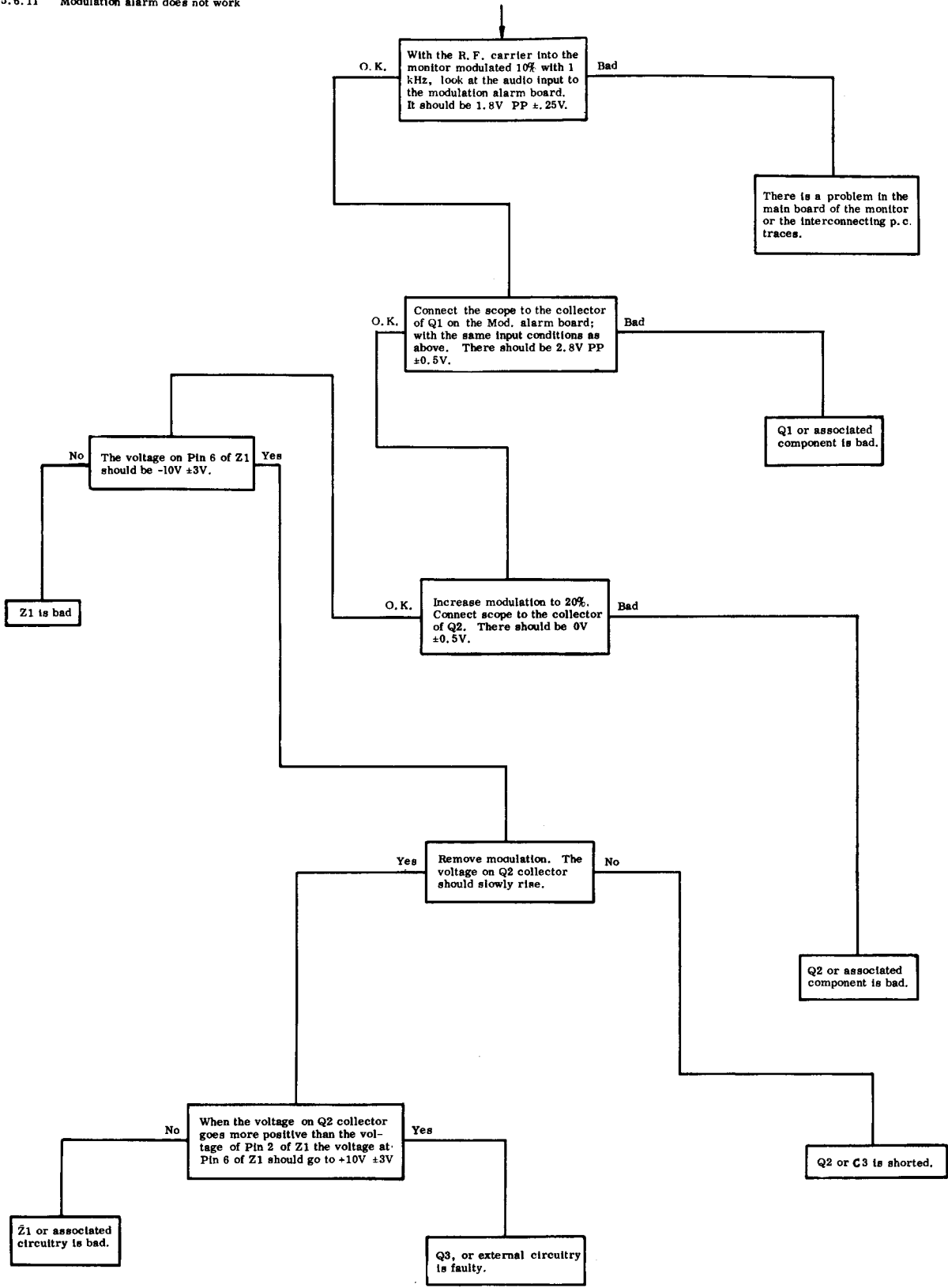

NEXT ASSY		USED ON		REVISIONS			
ITEM NO.	EN NO.	SYM	DESCRIPTION	DR	CHK	AUTH	DATE
		A	RELEASED PER ECO 3/5	RS			3-1-76

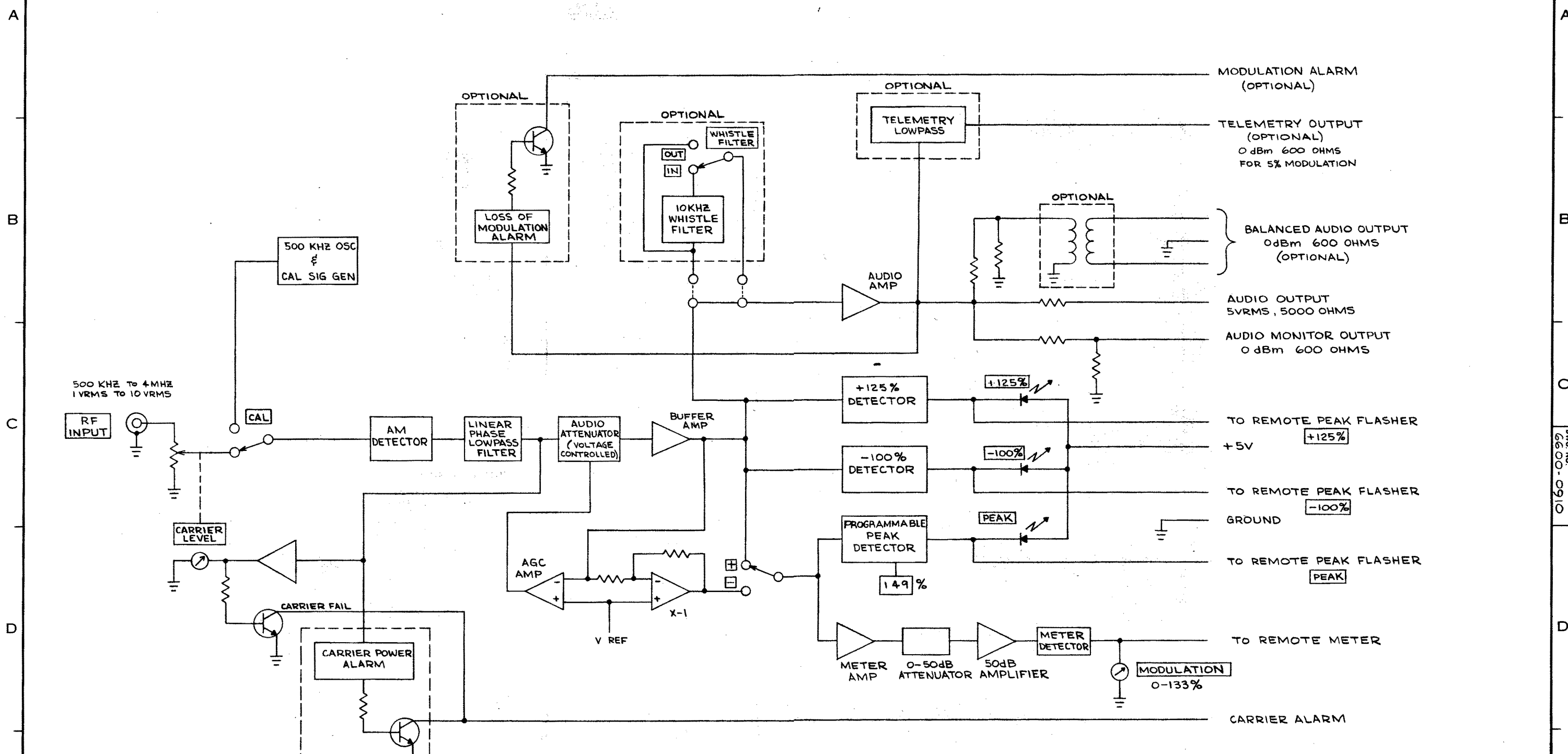

- MODULATION ALARM (OPTIONAL)
- TELEMETRY OUTPUT (OPTIONAL)
0 dBm 600 OHMS
FOR 5% MODULATION
- BALANCED AUDIO OUTPUT
0 dBm 600 OHMS
(OPTIONAL)
- AUDIO OUTPUT
5 VRMS, 5000 OHMS
- AUDIO MONITOR OUTPUT
0 dBm 600 OHMS
- TO REMOTE PEAK FLASHER
+125%
+5V
- TO REMOTE PEAK FLASHER
-100%
GROUND
- TO REMOTE PEAK FLASHER
PEAK
- TO REMOTE METER
- CARRIER ALARM

FIGURE 6-1

ITEM NO.	EN NO.	PART NO.	DESCRIPTION	REF. DES.
CITY PER ASSY				
REMOVE ALL BURRS AND SHARP EDGES			DRAWN BY S.L.L. DATE 11-25-75	
TOLERANCES UNLESS OTHERWISE SPECIFIED .XX ± ANGULAR .XXX ±			PROJ. ENG.	
DO NOT SCALE THIS PRINT			MFG. ENG.	
			APPD.	
			APPD.	
			ECO NO.	
			SCALE 1 of 1	

TET TIME & FREQUENCY TECHNOLOGY INC.
3000 Dicooff St. Santa Clara, California 95050
(408) 246-6365

TITLE
BLOCK DIAGRAM
AM MONITOR
MODEL 753

SIZE DRAWING NO. D 6600-0910
REV. A

DWG. NO. 6600-0910

MODEL 753

WIRING DIAGRAM ASSEMBLY

ASSEMBLY #6600-0932

CKT. REF.	DESCRIPTION	TFT STOCK NO.
C1	.0047 uf	1005-4749
C2	.0047 uf	1005-4749
CR1	LED HP 5082-4403	1285-4403
CR2	LED HP 5082-4403	1285-4403
CR3	LED HP 5082-4403	1285-4403
DS1	Lamp Assy.	4750-0006
DS2	Lamp Assy.	4750-0006
F1	1/4A SLO-BLO	1900-0004
F2	3/16A	1900-0022
M1	Meter	1400-7047
M2	Meter	1400-0500
R1	Attenuator, 50	1075-1001
R2	51 2W	1067-1551
R3	51 2W	1067-1551
S1	Thumbwheel Sw.	5102-1200
T1	Power Xfmr.	1500-8609

NEXT ASSY		USED ON		REVISIONS			
SYM	DESCRIPTION	DR	CHK	AUTH	DATE		
	753	A	RELEASED PER ECO 315	RS		3-1-78	MICRO
		B	REV PER ECO # 614	JT	482	8-21-78	MICRO
		C	REV PER ECO # 614	DC	90	3-5-79	

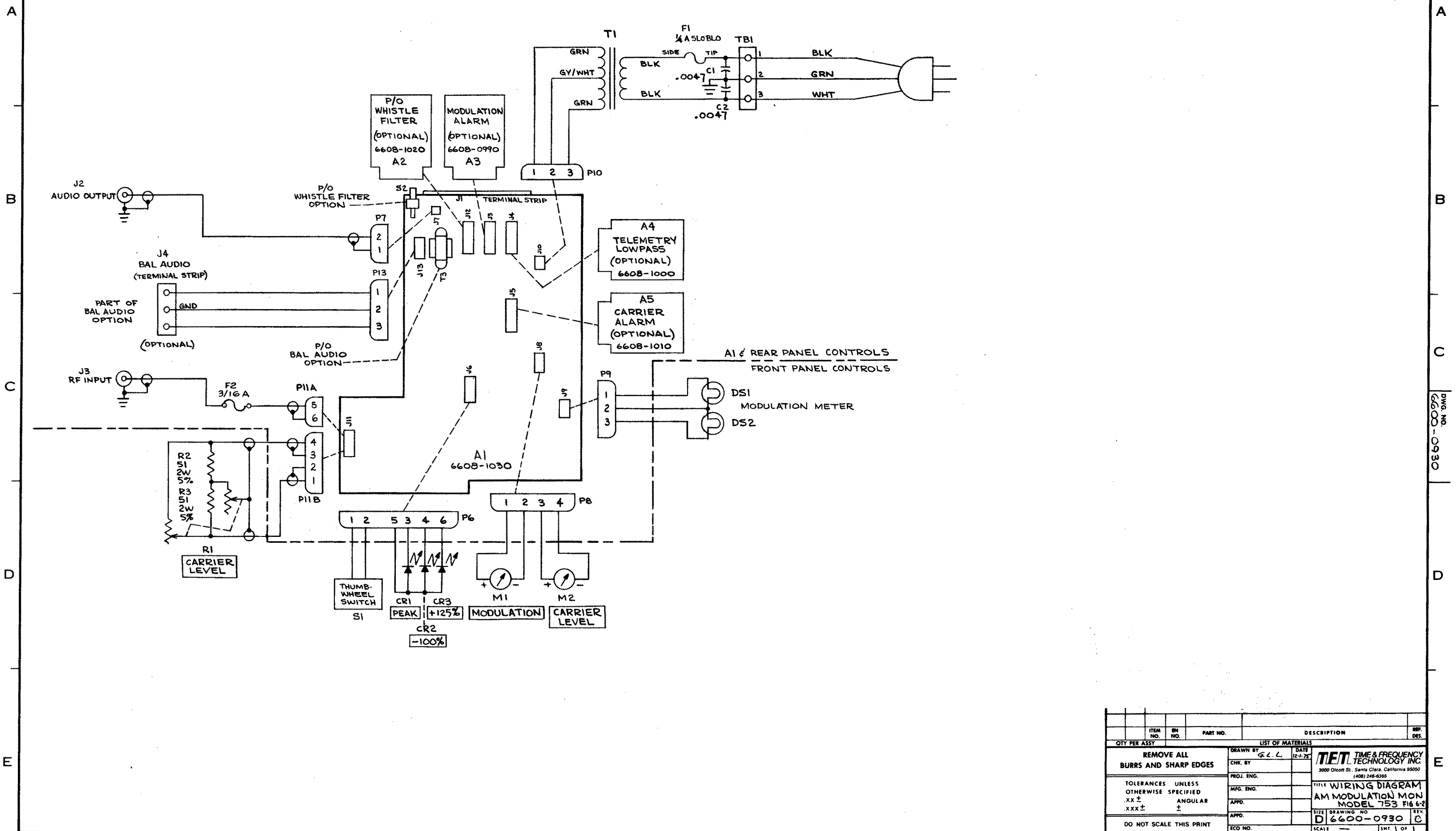

DWG. NO. 6600-0930

QTY PER ASSY	ITEM NO.	BN NO.	PART NO.	DESCRIPTION	REF. DES.
LIST OF MATERIALS					
REMOVE ALL BURRS AND SHARP EDGES		DRAWN BY G.L.L.		DATE 12-1-78	
TOLERANCES UNLESS OTHERWISE SPECIFIED		PROJ. ENG.		MFG. ENG.	
.XX ±		ANGULAR		±	
.XXX ±		ANGULAR		±	
DO NOT SCALE THIS PRINT		ECO NO.		SCALE	

NET TIME & FREQUENCY TECHNOLOGY INC.
 3000 Diecott St., Santa Clara, California 95050
 (408) 248-8365

TITLE: WIRING DIAGRAM
 AM MODULATION MON
 MODEL 753 FIG 6-2

SIZE: DRAWING NO. D 6600-0930
 REV. C

SCALE: — SHT 1 OF 1

CKT. REF.	DESCRIPTION	TFT STOCK NO.
CAPACITORS		
C1	100 uf 16 VDC Electro	1010-0101
C2	1000 uf 16 VDC Electro	1010-0102
C3	15 uf 25 VDC Electro	1010-0150
C4	300 pf 500WV Dipped Mica	1001-0301
C5	300 pf 500WV Dipped Mica	1001-0301
C6	220 uf 6 VDC Electro	1010-0251
C7	220 uf 6 VDC Electro	1010-0251
C8	220 uf 6 VDC Electro	1010-0251
C9	15 uf 25 VDC Electro	1010-0150
C10		
C11	560 pf 300 WV Dipped Mica	1001-0561
C12	15 uf 25 VDC Electro	1010-0150
C13	3.3 pf Tubular	1000-0033
C14	150 pf 500 WV Dipped Mica	1001-0151
C15	15 uf 25 VDC Electro	1010-0150
C16	10 uf 20 VDC Tant	1008-0100
C17	15 uf 25 VDC Electro	1010-0150
C18	2.2 uf 20 VDC Tant	1008-0022
C19	5.6 uf 20 VDC Tant	1008-0056
C20	470 uf 16 VDC Electro	1010-0471
C21	10 pf 500 WV Dipped Mica	1001-0100
C22	150 pf 600 WV Dipped Mica	1001-0151
C23	100 uf 16 VDC Electro	1010-0101
C24	150 pf 500 WV Dipped Mica	1001-0151
C25	2700 pf 300 WV Dipped Mica	1001-0272
C26	12 pf 500 WV Dipped Mica	1001-0120
C27	100 uf 16 VDC Electro	1001-0100
C28	510 pf 300 WV Dipped Mica 2%	1001-1501
C29	270 pf 500 WV Dipped Mica 2%	1001-2700
C30	1500 pf 300 WV Dipped Mica 2%	1001-1501
C31	1500 pf 300 WV Dipped Mica 2%	1001-1501
C32	15 uf 25 VDC Electro	1010-0150
C33	10 pf 500 WV Dipped Mica	1001-0100
C34	100 uf 16 VDC Electro	1010-0101
C35	15 uf 25 VDC Electro	1010-0150
C36	39 pf 500 WV Dipped Mica	1001-0390
C37	39 pf 500 WV Dipped Mica	1001-0390
C38	100 uf 16 VDC Electro	1010-0101
C39	500 uf 50 VDC Electro	1010-0501
C40	500 uf 50 VDC Electro	1010-0501
C41	10 uf 20 VDC Tant	1008-0100
C42	10 uf 20 VDC Tant	1008-0100

CKT. REF.	DESCRIPTION	TFT STOCK NO.
C44	10 uf 20 VDC Tant	1008-0100
C45	100 uf 16 VDC Electro	1010-0101
C46	1700 pf 300 WV Dipped Mica	1001-0172
C47	15 VDC Electro	1010-0101
C48	1500 pf 2% 300 WV Dipped Mica	1001-1501
C49	360 pf 2% 500 WV Dipped Mica	1001-3600
C50	510 pf 2% 300 WV Dipped Mica	1001-5100
C51	1000 uf 16 VDC Electro	1010-0102
C52	15 uf 25 VDC Electro	1010-0150
C53	15 uf 25 VDC Electro	1010-0150
C54	50 uf 16 VDC Electro	1010-0150
C55	15 uf 25 VDC Electro	1010-0150
C56	15 uf 25 VDC Electro	1010-0150
C57	15 uf 25 VDC Electro	1010-0150
C58	15 uf 25 VDC Electro	1010-0150
C59	15 uf 25 VDC Electro	1010-0150
C60	15 uf 25 VDC Electro	1010-0150
C61	24 pf 500 VDC Dip Mica	1001-0240
C62	24 pf 500 VDC Dip Mica	1001-0240
CR1	HP 2800 No Sub Acceptable	1282-2800
CR2	HP 2800 No Sub Acceptable	1282-2800
CR3	HP2800 No Sub Acceptable	1282-2800
CR4	1N4734 Zener Diode	1283-4734
CR5	1N4735 Zener Diode	1283-4735
CR6	HP-2800 Hot Carr Diode	1282-2800
CR7	HP-2800 Hot Carr Diode	1282-2800
CR8	HP-2800 Hot Carr Diode	1282-2800
CR9	1N4002 Rectifier	1284-4002
CR10	1N4002 Rectifier	1284-4002
CR11	1N4002 Rectifier	1284-4002
CR12	1N4002 Rectifier	1284-4002
CR13	1N4735 Zener Diode	1283-4735
CR14	1N4735 Zener Diode	1283-4735
CR15	1N3064 Gen. Purp. Diode	1281-3064
CR16	1N3064 Gen. Purp. Diode	1281-3064
CR17	1N4745 Zener Diode	1283-4745
CR18	1N4745 Zener Diode	1283-4745
CR19	1N3064 Gen. Purp. Diode	1281-3064
CR20	1N6110	1281-6110
TRANSISTORS		
Q1	2N3643	1271-3643

CKT. REF.	DESCRIPTION	TFT STOCK NO.
Q2	2N3643	1271-3643
Q3	2N3643	1271-3643
Q4	2N4275	1271-4275
Q5	2N4275	1271-4275
Q6	2N3643	1271-3643
Q7	2N3643	1271-3643
Q8	2N3643	1271-3643
Q9	2N3643	1271-3643
Q10	2N3643	1271-3643
Q11	2N3643	1271-3643
RESISTORS		
R1	56 ohm +5% 1/4 watt Carbon Comp	1065-0056
R2	150 ohm +5% 1/4 watt Carbon Comp	1065-0150
R3	150 ohm +5% 1/4 watt Carbon Comp	1065-0150
R4	2.2K +5% 1/4 watt Carbon Comp	1065-2201
R5	2.2K +5% 1/4 watt Carbon Comp	1065-2201
R6	2.2K +5% 1/4 watt Carbon Comp	1065-2201
R7	100 ohm +5% 1/4 watt Carbon Comp	1065-0100
R8	220 ohm +5% 1/4 watt Carbon Comp	1065-0220
R9	3.3K +5% 1/4 watt Carbon Comp	1065-3301
R10	4.7K +5% 1/4 watt Carbon Comp	1065-4701
R11	560 ohm +5% 1/4 watt Carbon Comp	1065-0560
R12	47K +5% 1/4 watt Carbon Comp	1065-4702
R13	1K 1 Turn PC Mount	1072-1001
R14	4.7K +5% 1/4 watt Carbon Comp	1065-4701
R15	100 ohm 1 Turn PC Mount	1072-0100
R16	4.7K +5% 1/4 watt Carbon Comp	1065-4701
R17	10 ohm +5% 1/4 watt Carbon Comp	1065-0010
R18	180 ohm +5% 1/4 watt Carbon Comp	1065-0180
R19	6.8K +5% 1/4 watt Carbon Comp	1065-6801
R20	1K +5% 1/4 watt Carbon Comp	1065-1001
R21	1K +5% 1/4 watt Carbon Comp	1065-1001
R22	6.8K +5% 1/4 watt Carbon Comp	1065-6801
R23	6.8K +5% 1/4 watt Carbon Comp	1065-6801
R24	1K +5% 1/4 watt Carbon Comp	1065-1001
R25	180 +5% 1/4 watt Carbon Comp	1065-0180
R26	180 +5% 1/4 watt Carbon Comp	1065-0180
R27	180 +5% 1/4 watt Carbon Comp	1065-0180
R28	180 +5% 1/4 watt Carbon Comp	1065-0180
R29	180 +5% 1/4 watt Carbon Comp	1065-0180
R30	820 +5% 1/4 watt Carbon Comp	1065-0820
R31	820 +5% 1/4 watt Carbon Comp	1065-0820

CKT. REF.	DESCRIPTION	TFT STOCK NO.
R32	2K +5% 1/4 watt Carbon Comp	1065-2001
R33	470 +5% 1/4 watt Carbon Comp	1065-0470
R34	2K +5% 1/4 watt Carbon Comp	1065-2001
R35	820 +5% 1/4 watt Carbon Comp	1065-0820
R36	150K +5% 1/4 watt Carbon Comp	1065-1503
R37	10K +5% 1/4 watt Carbon Comp	1065-1002
R38	10K .1% 1/8 watt Metal Film	1058-1002
R39	10K .1% 1/8 watt Metal Film	1058-1002
R40	4.7K +5% 1/4 watt Carbon Comp	1065-4701
R41	470 +5% 1/4 watt Carbon Comp	1065-0470
R42	5.6K +5% 1/4 watt Carbon Comp	1065-5601
R43	3.3K +5% 1/4 watt Carbon Comp	1065-3301
R44	100 1 Turn PC Mount	1072-0100
R45	560 +5% 1/4 watt Carbon Comp	1065-0560
R46	330 +5% 1/4 watt Carbon Comp	1065-0330
R47	390 +5% 1/4 watt Carbon Comp	1065-0390
R48	100 ohm 1 Turn P.C. Mount	1072-0100
R49	10K +5% 1/4 watt Carbon Comp	1065-1002
R50	10K +5% 1/4 watt Carbon Comp	1065-1002
R51	470 +5% 1/4 watt Carbon Comp	1065-0470
R52	330 +5% 1/4 watt Carbon Comp	1065-0330
R53	2.4K +5% 1/4 watt Carbon Comp	1065-2401
R54	2.4K +5% 1/4 watt Carbon Comp	1065-2401
R55	220 +5% 1/4 watt Carbon Comp	1065-0220
R56	2K 1% 1/8 watt Metal Film	1061-2001
R57	261 1% 1/8 watt Metal Film	1061-0261
R58	5.6K +5% 1/4 watt Carbon Comp	1065-5601
R59	5.6K +5% 1/4 watt Carbon Comp	1065-5601
R60	10K +5% 1/4 watt Carbon Comp	1065-1002
R61	39K +5% 1/4 watt Carbon Comp	1065-3902
R62	1K +5% 1/4 watt Carbon Comp	1065-1001
R63	5K 10 Turn PC Mount	1069-5001
R64	13K 1% 1.8 watt Metal Film	1061-1302
R65	261 1% 1/8 watt Metal Film	1061-0261
R66	2K 1% 1/8 watt Metal Film	1061-2001
R67	1K 1% 1/8 watt Metal Film	1061-1001
R68	1K 1% 1/8 watt Metal Film	1061-1001
R69	150 +5% 1/4 watt Carbon Comp	1065-0150
R70	33 ohm +5% 1/4 watt Carbon Comp	1065-0033
R71	1K 1% 1/8 watt Metal Film	1061-1001
R72	1K 1% 1/8 watt Metal Film	1061-1001
R73	750 1% 1/8 watt Metal Film	1062-0750
R74	160 +5% 1/4 watt Carbon Comp	1065-0160

CKT. REF.	DESCRIPTION	TFT STOCK NO.
R75	330 +5% 1/4 watt Carbon Comp	1065-0330
R76	1.37K 1% 1/8 watt Metal Film	1061-1370
R77	432 1% 1/8 watt Metal Film	1061-0432
R78	137 1% 1/8 watt Metal Film	1061-0137
R79	43.2 1% 1/8 watt Metal Film	1061-0432
R80	13.7 1% 1/8 watt Metal Film	1061-0137
R81	12.7 1% 1/8 watt Metal Film	1061-0012
R82	12.7 1% 1/8 watt Metal Film	1061-0012
R83	100 1% 1/8 watt Metal Film	1061-0100
R84	8251K 1/8 watt Metal Film	1061-0825
R85	100 ohm 1 Turn PC Mount	1072-0100
R86	1K +5% 1/4 watt Carbon Comp	1065-1001
R87	51 +5% 1/4 watt Carbon Comp	1065-0051
R88	495 1% 1/8 watt Metal Film	1061-0495
R89	5151 +5% 1/4 watt Carbon Comp	1065-0051
R90	1 meg +5% 1/4 watt Carbon Comp	1065-1004
R91	15K 1% 1/8 watt Metal Film	1061-1502
R92	33 ohm +5% 1/4 watt Carbon Comp	1065-0033
R93	1.5K +5% 1/4 watt Carbon Comp	1065-1501
R94	8.2K +5% 1/4 watt Carbon Comp	1065-8201
R95	750 +5% 1/4 watt Carbon Comp	1065-0750
R96	330 +5% 1/4 watt Carbon Comp	1065-0330
R97	22 ohm +5% watt Wire Wound	1068-0022
R98	1K +5% 1/4 watt Carbon Comp	1065-1001
R99	5.1K +5% 1/4 watt Carbon Comp	1065-0470
R100	1K +5% 1/4 watt Carbon Comp	1065-1001
R101	931 1% 1/8 watt Metal Film	1061-0930
R102	150 ohm 1/2 watt Carbon Comp	1067-0150
R103	100 ohm 1 Turn PC Mount	1072-0100
R104	1K 1 Turn PC Mount Pot	1072-1001
R105	51 ohm +5% 1/4 watt Carbon Comp	1065-0051
R106	51 ohm +5% 1/4 watt Carbon Comp	1065-0051
R107	10 ohm +5% 1/4 watt Carbon Comp	1065-0010
R108	10 ohm +5% 1/4 watt Carbon Comp	1065-0010
R109	10 ohm +5% 1/4 watt Carbon Comp	1065-0010
R110	10 ohm +5% 1/4 watt Carbon Comp	1065-0010
R111	150 ohm +5% 1/2 watt Carbon Comp	1065-0150
R112	22 ohm +5% 5 watt Wire Wound	1068-0022
R113	1.5K +5% 1/4 watt Carbon Comp	1065-1501
R114	1K +5% 1/4 watt Carbon Comp	1065-1001
R115	1K +5% 1/4 watt Carbon Comp	1065-1001

CKT. REF.	DESCRIPTION	TFT STOCK NO.
SWITCHES		
S1	Ganged SW. ST1 - P. O., ST2-3 Gang, ST4-9 Gang	1850-1009
S2	SPDT (Whistle Filter)	1800-1010
TRANSFORMERS		
T1	AM Input Transformer	1501-0002
T2	Trifilar	1501-0001
T3	Bal. Audio Transformer	1480-0002
IC's		
Z1	7400	1100-7400
Z2	7476	1100-7476
Z3	7493	1100-7493
Z4	7493	1100-7493
Z5	710	1100-0710
Z6	710	1100-0710
Z7	710	1100-0710
Z8	7430	1100-7430
Z9	SP380	1100-0380
Z10	SP380	1100-0380
Z11	741	1100-0741
Z12	CLM 6000	1099-0001
Z13	741	1100-0741
Z14	301	1100-0301
Z15	741	1100-0741
Z16	741	1100-0741
Z17	302	1100-0302
Z18	302	1100-0302
Z19	301	1100-0301
Z20	LM301	1100-0301
Z21	LM301	1100-0301
Z22	LM741	1100-0741
Z23	LM341P	1100-4102
Z24	LM3420	1100-4212
Z25	7912	1100-2012
Z26	LM741	1100-0741
Z27	LM741	1100-0741

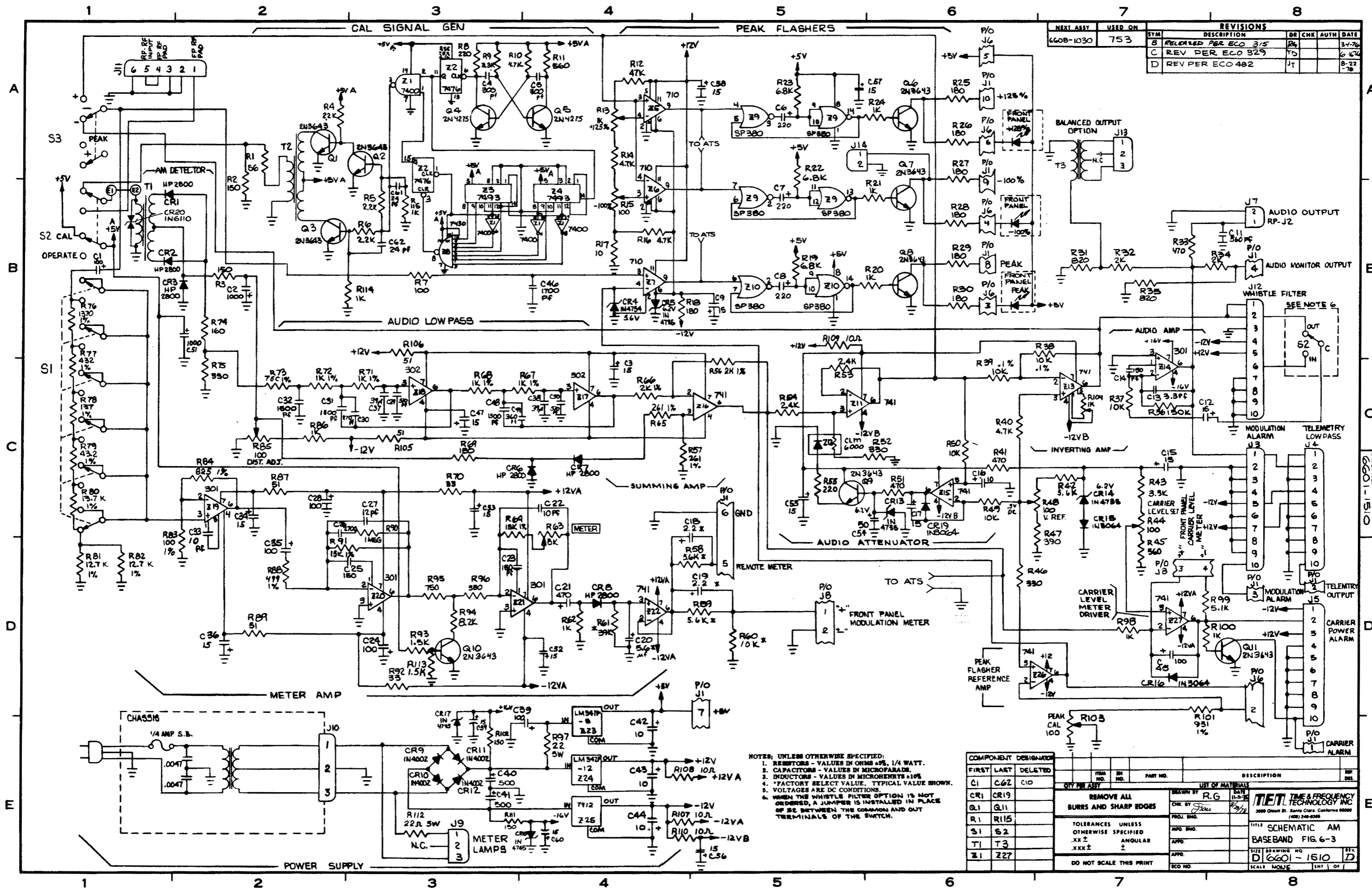

NEXT ASSY		USED ON		REVISIONS			
SYM	DESCRIPTION	DR	CHK	AUTH	DATE		
660B-1030	753	B	RELEASED PER ECO 315	Rg			3-1-76
		C	REV PER ECO 329	TD			6-1-76
		D	REV PER ECO 482	JT			8-27-78

- NOTES: UNLESS OTHERWISE SPECIFIED:
1. RESISTORS - VALUES IN OHMS ±5%, 1/4 WATT.
 2. CAPACITORS - VALUES IN MICROFARADS.
 3. INDUCTORS - VALUES IN MICROHENRS ±10%.
 4. *FACTORY SELECT VALUE. TYPICAL VALUE SHOWN.
 5. VOLTAGES ARE DC CONDITIONS.
 6. WHEN THE WHISTLE FILTER OPTION IS NOT ORDERED, A JUMPER IS INSTALLED IN PLACE OF S2 BETWEEN THE COMMON AND OUT TERMINALS OF THE SWITCH.

COMPONENT DESIGNATOR	FIRST	LAST	DELETED
C1	C62	C10	
CR1	CR19		
Q1	Q11		
R1	R115		
S1	S2		
T1	T3		
Z1	Z27		

QTY	PER ASSY	LIST OF MATERIALS	DESCRIPTION	REF. DES.
		REMOVE ALL BURRS AND SHARP EDGES		
		TOLERANCES UNLESS OTHERWISE SPECIFIED		
		.XX ±	ANGULAR	
		.XXX ±		
		DO NOT SCALE THIS PRINT		

NET TIME & FREQUENCY TECHNOLOGY INC.
 3000 Olcott St. Santa Clara, California 95050
 (408) 248-0368

TITLE: SCHEMATIC AM BASEBAND FIG. 6-3
 SIZE: DRAWING NO. D 6601-1510
 SCALE: NONE

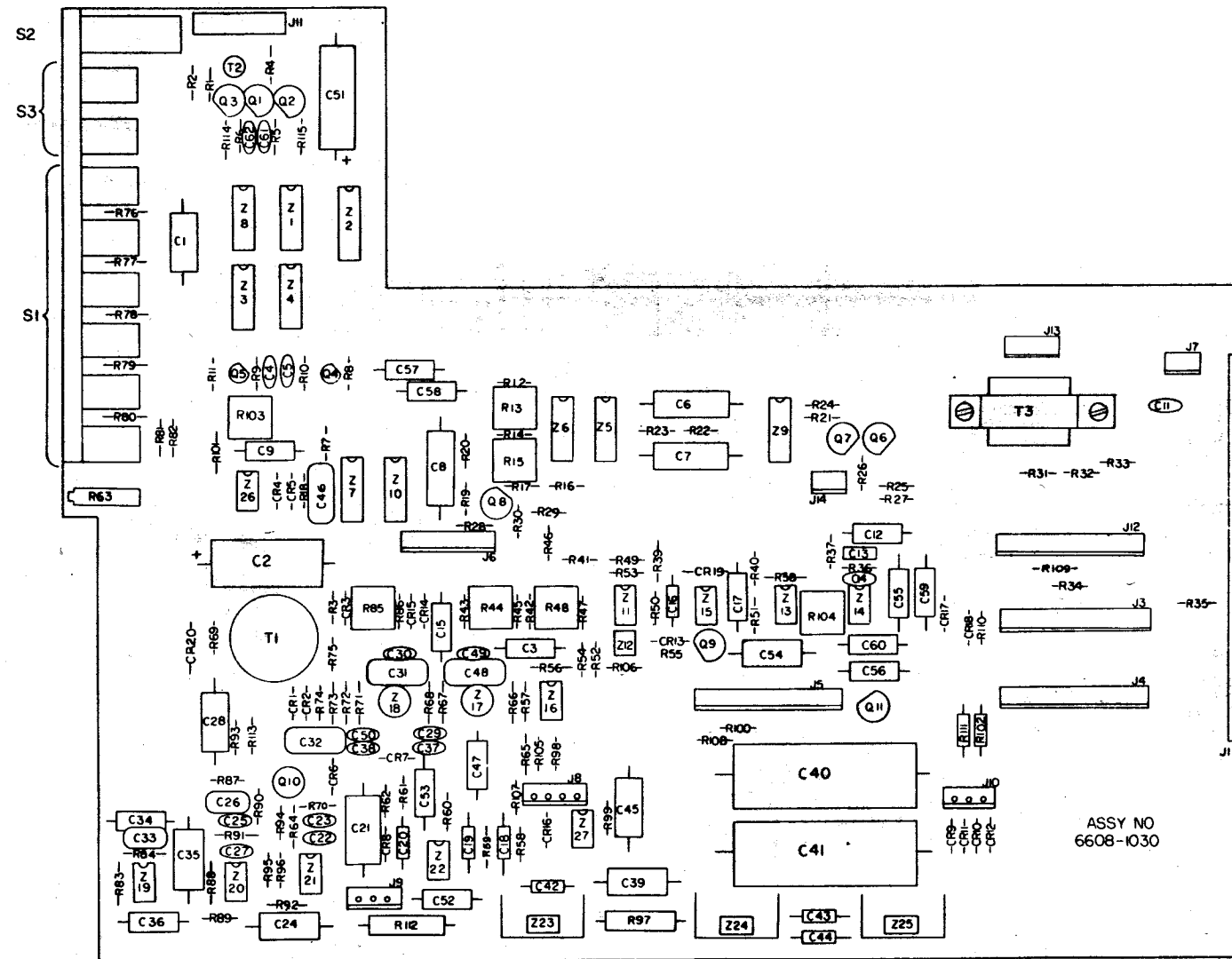

CKT. REF.	DESCRIPTION	TFT STOCK NO.
CAPACITORS		
C1	1000 pf +5% Dipped Mica 100V	1001-0102
C2	39 pf +5% Dipped Mica 100V	1001-0390
C3	9-35 pF Variable	1012-9035
C4	2000 pf +5% Dipped Mica 100V	1001-0202
C5	100 pf +5% Dipped Mica 100V	1001-0101
C6	9-35 pF Variable	1012-9035
C7	15 uf 25 VDC Electro	1010-0150
C8	15 uf 25 VDC Electro	1010-0150
C9	1000 pf +5% Dipped Mica 100V	1001-0102
C10	39 pf +5% Dipped Mica 100V	1001-0390
P12	Connector, Molex #09-52-3101	2250-5210
PCB	Whistle Filter	1600-1020
RESISTORS		
R1	10 ohm +5% 1/4 watt Carbon Comp	1065-0010
R2	15K +1% 1/8 watt Metal Film	1061-0010
R3	7.5K +1% 1/8 watt Metal Film	1061-7501
R4	15K +1% 1/8 watt Metal Film	1061-1502
R5	1K +5% 1/4 watt Carbon Comp	1065-1001
R6	10K +5% 1/4 watt Carbon Comp	1065-1002
R7	10 ohm +5% 1/4 watt Carbon Comp	1065-0010
R8	10 ohm +5% 1/4 watt Carbon Comp	1065-0020
IC's		
Z1	LM741	1100-0741
Z2	LM741	1100-0741

DWG. NO.
6601-1550

NEXT ASSY		USED ON		REVISIONS				
SYM	DESCRIPTION	DR	CHK	AUTH	DATE			
6608-1020	753	A	RELEASED PER ECO	315	RG			3-1-76

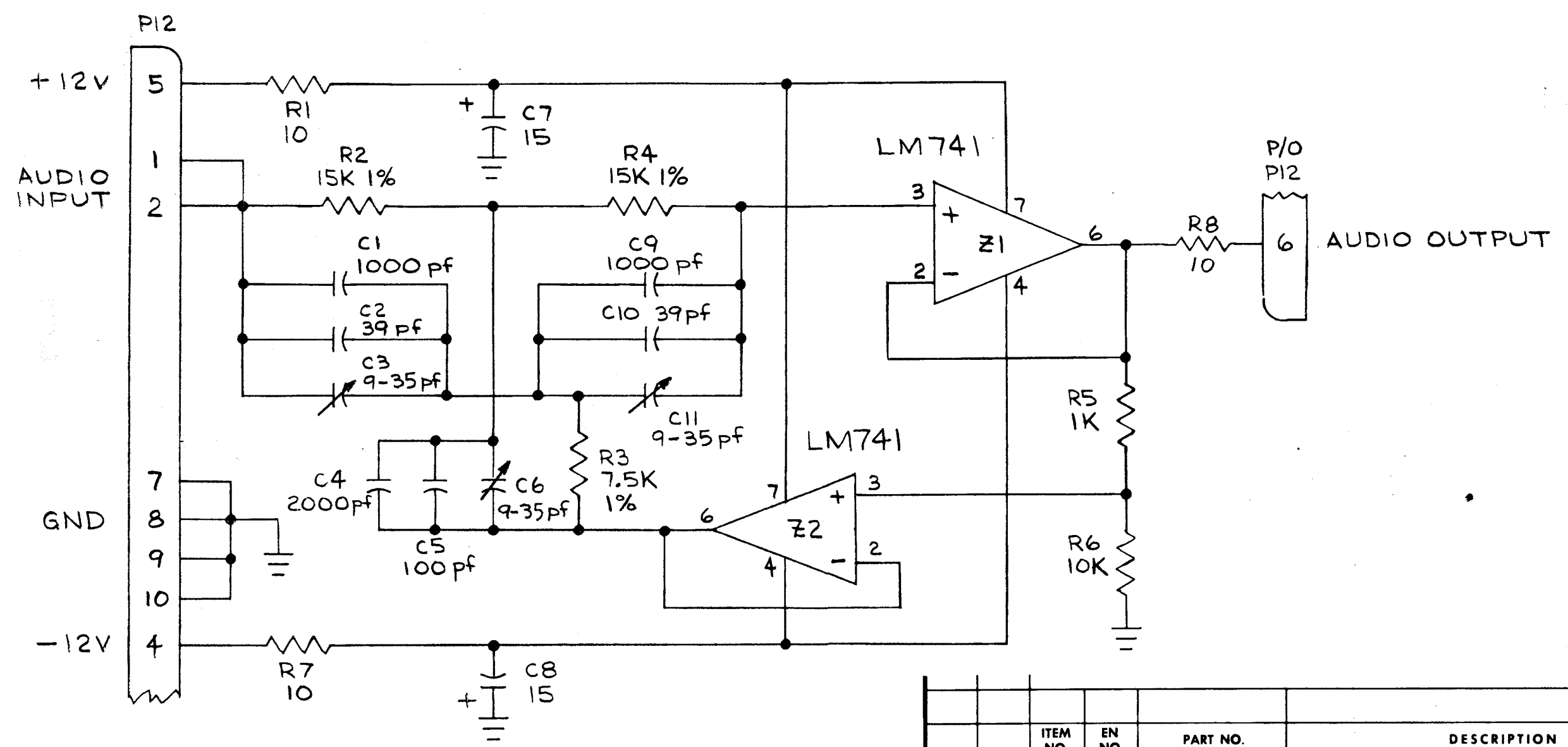

- NOTES; UNLESS OTHERWISE SPECIFIED:
1. RESISTORS - VALUES IN OHMS $\pm 5\%$, 1/4 WATT.
 2. CAPACITORS - VALUES IN MICROFARADS.
 3. INDUCTORS - VALUES IN MICROHENRYS $\pm 10\%$
 4. *FACTORY SELECT VALUE. TYPICAL VALUE SHOWN.
 5. VOLTAGES ARE DC CONDITIONS.

ITEM NO.	EN NO.	PART NO.	DESCRIPTION	REF. DES.
QTY PER ASSY				
LIST OF MATERIALS				
REMOVE ALL BURRS AND SHARP EDGES			DRAWN BY G.L.L.	DATE 11-25-76
TOLERANCES UNLESS OTHERWISE SPECIFIED			CHK. BY	
.xx \pm			PROJ. ENG.	
.xxx \pm			MFG. ENG.	
DO NOT SCALE THIS PRINT			APPD.	
			APPD.	
			ECO NO.	
			TFT TIME & FREQUENCY TECHNOLOGY INC. 3000 Olcott St., Santa Clara, California 95050 (408) 246-6365	
			TITLE SCHEMATIC WHISTLE FILTER FIGURE 6-4	
SIZE B		DRAWING NO. 6601-1550		REV. A
SCALE			SHT. 1 OF 1	

CKT. REF.	DESCRIPTION	TFT STOCK NO.
CAPACITORS		
C1	15 uf Electrolytic 25V	1010-0150
C2	1 uf Mylar 100V +2%	1004-0002
C3	15 uf Electrolytic 25V	1010-0150
C4	6.8 uf Tant 25V	1008-0068
C5	.027 uf Mylar	1006-0270
	Socket 8 Pin	2250-1008
P4	Connector, Molex #09-52-3101	2250-5210
RESISTORS		
R1	10 ohm +5% 1/4 watt Carbon Comp	1065-0010
R2	10K +5% 1/4 watt Carbon Comp	1065-1002
R3	10 ohm +5% 1/4 watt Carbon Comp	1065-0010
R4	10K +5% 1/4 watt Carbon Comp	1065-1002
R5	10K +5% 1/4 watt Carbon Comp	1065-1002
R6	9.1K +5% 1/4 watt Carbon Comp	1065-9191
R7	8.2K +5% 1/4 watt Carbon Comp	1065-8201
R8	47K +5% 1/4 watt Carbon Comp	1065-4702
R9	560 ohm +5% 1/4 watt Carbon Comp	1065-0560
I.C.s		
Z1	LM741	1100-0741
Z2	LM741	1100-0741

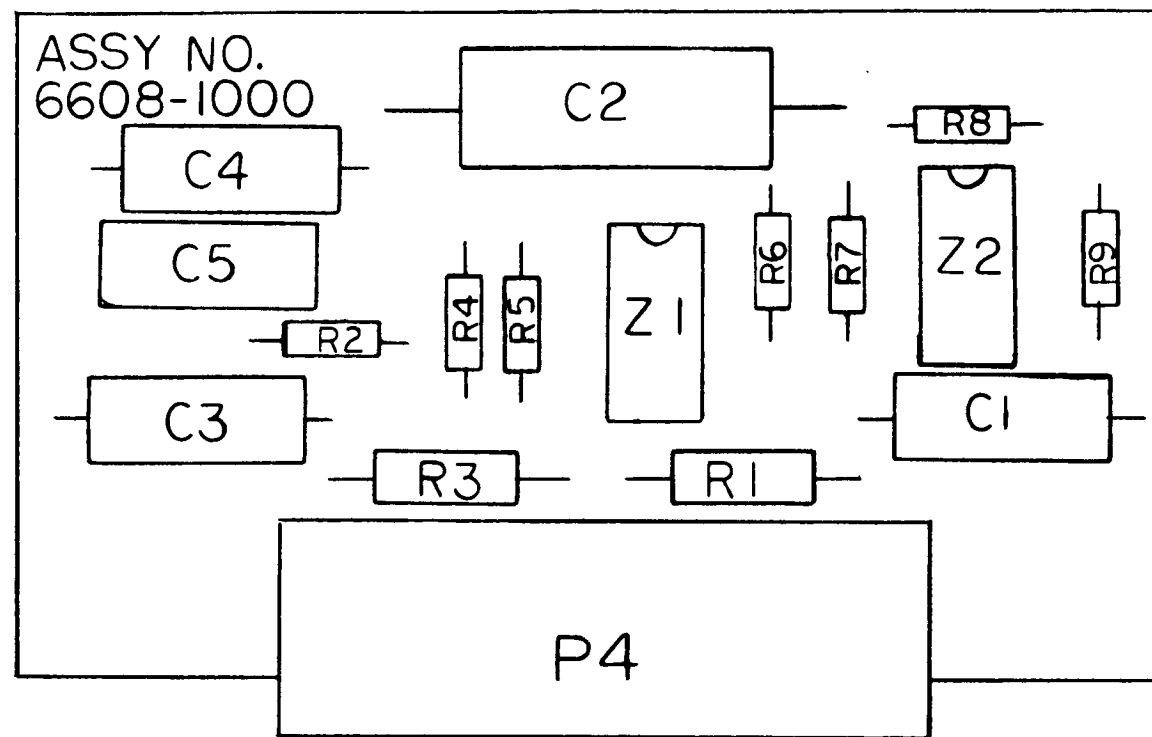

DWG. NO.
6601-1530

NEXT ASSY	USED ON	REVISIONS			
SYM	DESCRIPTION	DR	CHK	AUTH	DATE
6608-1000	753	A	RELEASED PER ECO 315	RG	3-1-76

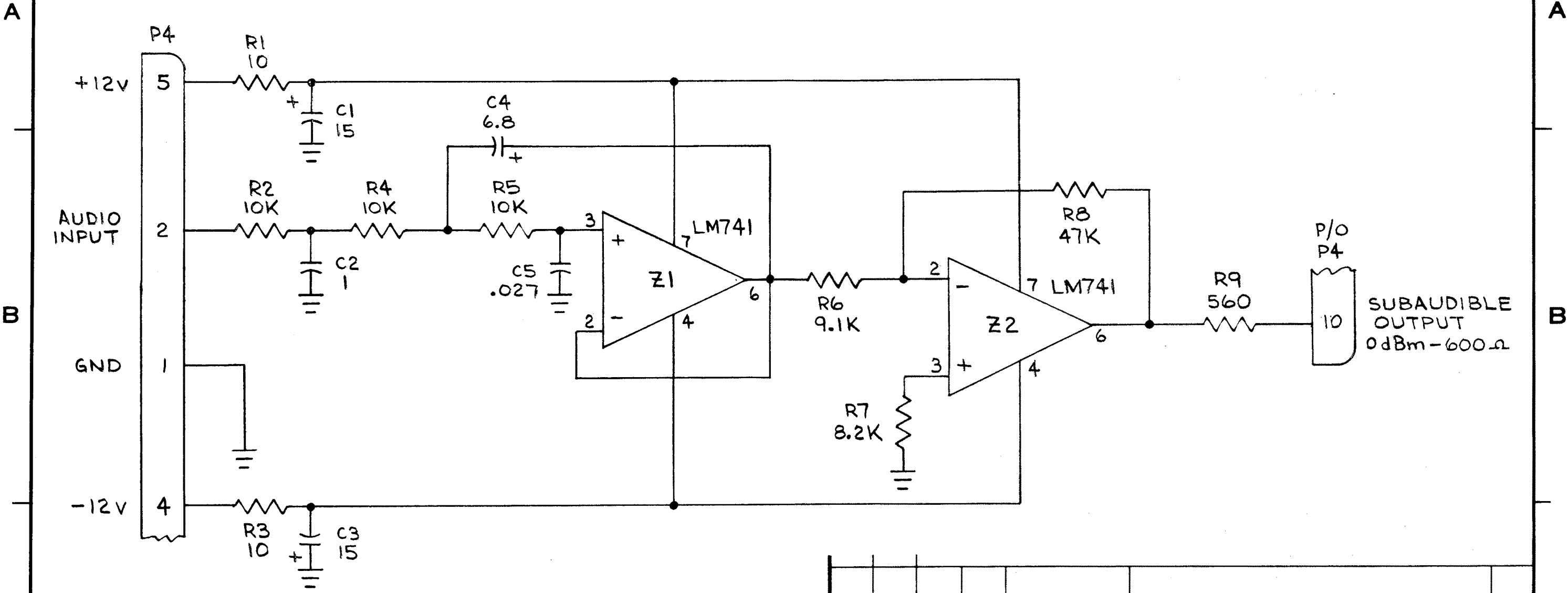

- NOTES; UNLESS OTHERWISE SPECIFIED:
1. RESISTORS - VALUES IN OHMS $\pm 5\%$, 1/4 WATT.
 2. CAPACITORS - VALUES IN MICROFARADS.
 3. INDUCTORS - VALUES IN MICROHENRYS $\pm 10\%$
 4. *FACTORY SELECT VALUE. TYPICAL VALUE SHOWN.
 5. VOLTAGES ARE DC CONDITIONS.

ITEM NO.	EN NO.	PART NO.	DESCRIPTION	REF. DES.
LIST OF MATERIALS				
REMOVE ALL BURRS AND SHARP EDGES				
TOLERANCES UNLESS OTHERWISE SPECIFIED		DRAWN BY	DATE	TFT TIME & FREQUENCY TECHNOLOGY INC. 3000 Olcott St., Santa Clara, California 95050 (408) 246-6365 TITLE SCHEMATIC TELEMETRY LOWPASS FIGURE 6-5
.XX \pm	ANGULAR \pm	CHK. BY		
.XXX \pm		PROJ. ENG.		
DO NOT SCALE THIS PRINT		MFG. ENG.		
		APPD.		
		APPD.		SIZE B DRAWING NO. 6601-1530 REV. A SCALE - SHT. 1 OF 1

CKT. REF.	DESCRIPTION	TFT STOCK NO.
CAPACITORS		
C1	1000 pf +5% Dipped Mica 100V	1001-0102
C2	1000 pf +5% Dipped Mica 100V	1001-0102
C3	15 uf 25 VDC Electro	1010-0150
C4	15 uf 25 VDC Electro	1010-0150
DIODES		
CR1	IN3064	1281-3064
CR2	IN3064	1281-3064
P5	Connector Molex #09-52-3101	2250-5210
PCB	Carrier Alarm	1600-1010
TRANSISTORS		
Q1	2N3643	1271-3643
RESISTORS		
R1	82K +5% 1/4 watt Carbon Comp	1065-8201
R2		
R3	22K + 5% 1/4 watt Carbon Comp	1065-2202
R4	1K Pot 1 Turn PC Mount	1072-1001
R5	1K Pot 1 Turn PC Mount	1072-1001
R6	7.5K +5% 1/4 watt Carbon Comp	1065-7501
R7	10K +5% 1/4 watt Carbon Comp	1065-1002
R8	1K +5% 1/4 watt Carbon Comp	1065-1001
R9	1K +5% 1/4 watt Carbon Comp	1065-1001
R10	1K +5% 1/4 watt Carbon Comp	1065-1001
R11	1K +5% 1/4 watt Carbon Comp	1065-1001
I.C.'s		
Z1	LM741	1100-0741
Z2	LM741	1100-0741
	Socket 8 Pin	2250-1008
	Socket Transistor	1150-0001

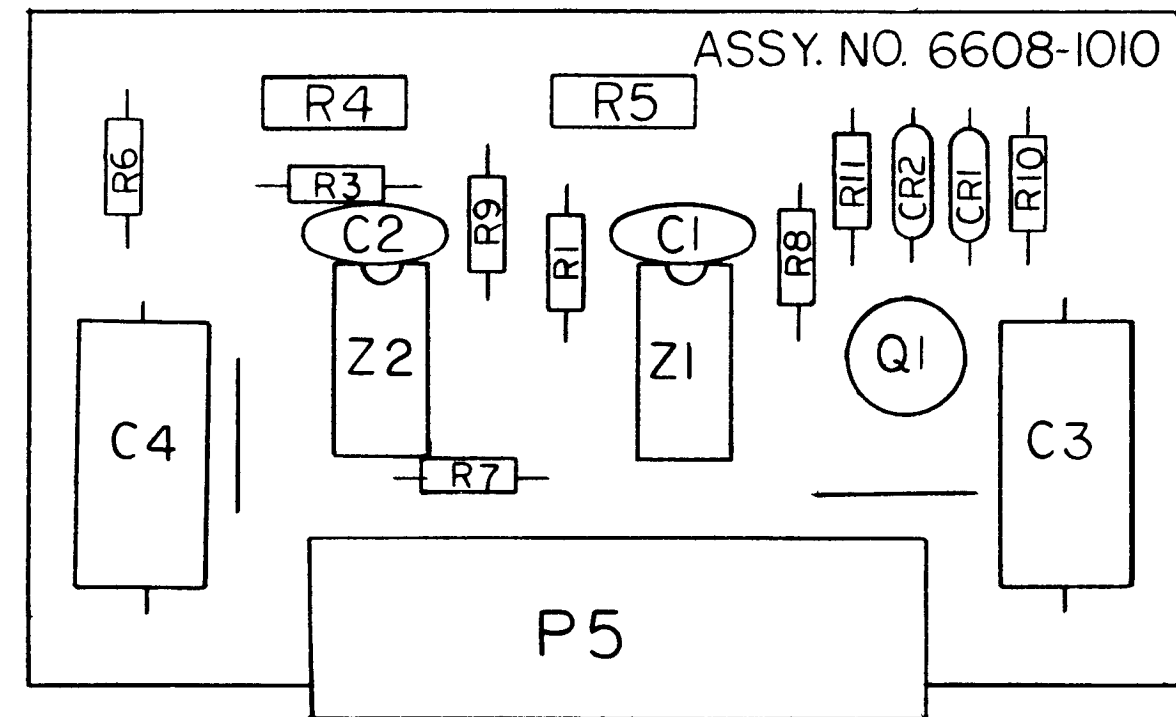

NEXT ASSY		USED ON		REVISIONS			
SYM	DESCRIPTION	DR	CHK	AUTH	DATE		
6608-1010	753	A	RELEASED PER ECO 315			RG	3-1-76

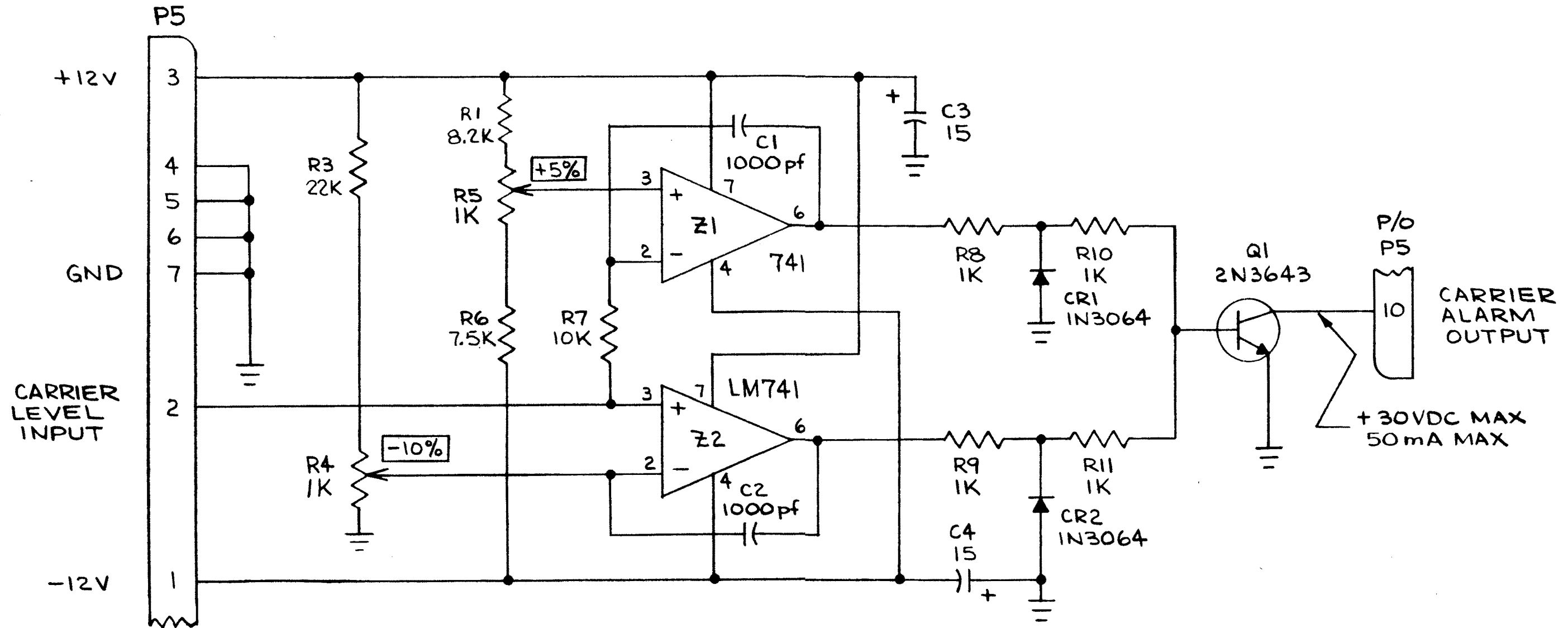

- NOTES; UNLESS OTHERWISE SPECIFIED:
1. RESISTORS - VALUES IN OHMS $\pm 5\%$, 1/4 WATT.
 2. CAPACITORS - VALUES IN MICROFARADS.
 3. INDUCTORS - VALUES IN MICROHENRYS $\pm 10\%$
 4. *FACTORY SELECT VALUE. TYPICAL VALUE SHOWN.
 5. VOLTAGES ARE DC CONDITIONS.

ITEM NO.	EN NO.	PART NO.	DESCRIPTION	REF. DES.
QTY PER ASSY				
LIST OF MATERIALS				
REMOVE ALL BURRS AND SHARP EDGES			DRAWN BY	DATE
			G.L.L.	11-24-75
TOLERANCES UNLESS OTHERWISE SPECIFIED .XX \pm .XXX \pm			CHK. BY	
			PROJ. ENG.	
DO NOT SCALE THIS PRINT			MFG. ENG.	
			APPD.	
			APPD.	
			APPD.	
			ECO NO.	
			ECO NO.	
			DRAWN BY	
			G.L.L.	
			DATE	
			11-24-75	
			TIME & FREQUENCY TECHNOLOGY INC. 3000 Olcott St., Santa Clara, California 95050 (408) 246-6385	
SCHEMATIC CARRIER ALARM				
			SIZE	REV.
			B	A
			DRAWING NO.	
			6601-1540	
			SCALE	SHT. OF

CKT. REF.	DESCRIPTION	TFT STOCK NO.
CAPACITORS		
C1	15 uf 25VDC Electro	1010-0150
C2	15 uf 25VDC Electro	1010-0150
C3	100 uf 16VDC Electro	1010-0101
C4	1000 pf +5% Dipped Mica 100V	1001-0102
C5	15 uf 25VDC Electro	1010-0150
C6	15 uf 25VDC Electro	1010-0150
DIODES		
CR1	IN3064	1281-3064
P3	Connector Molex Socket Transistor	2250-5210 1150-0001
P.C.B.	Modulation Alarm	1600-0990
TRANSISTORS		
Q1	2N5087	1271-5087
Q2	2N4275	1271-4275
Q3	2N3643	1271-3643
RESISTORS		
R1	1K +5% 1/4 watt Carbon Comp	1065-1001
R2	1.8K +5% 1/4 watt Carbon Comp	1065-1801
R3	12K +5% 1/4 watt Carbon Comp	1065-1202
R4	150 ohm +5% 1/4 watt Carbon Comp	1065-0150
R5	560 ohm +5% 1/4 watt Carbon Comp	1065-0560
R6	1K +5% 1/4 watt Carbon Comp	1065-1001
R7	1K +5% 1/4 watt Carbon Comp	1065-1001
R8	100K +5% 1/4 watt Carbon Comp	1065-1003
R9	100K +5% 1/4 watt Carbon Comp	1065-1003
R10	10K Pot 1 Turn P.C. Mount	1072-1002
R11	1K +5% 1/4 watt Carbon Comp	1065-1001
R12	10 ohm +5% 1/4 watt Carbon Comp	1065-0010
R13	2.2K +5% 1/4 watt Carbon Comp	1065-2201
R14	10 ohm +5% 1/4 watt Carbon Comp	1065-0010
IC's		
Z1	LM 741	1100-0741

Socket 8 Pin

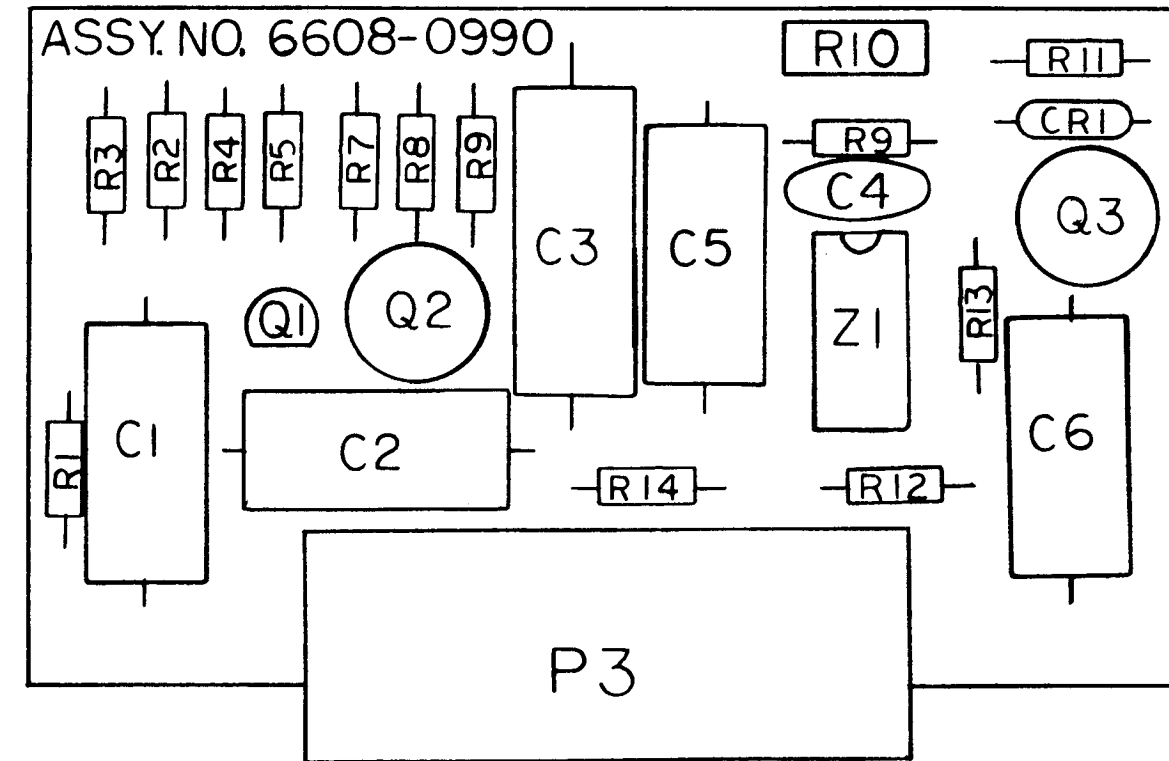

DWG. NO.
6601-1520

NEXT ASSY		USED ON		REVISIONS			
SYM	DESCRIPTION	DR	CHK	AUTH	DATE		
6608-0990	753	A	RELEASED PER ECO 315	RG	3-1-76		

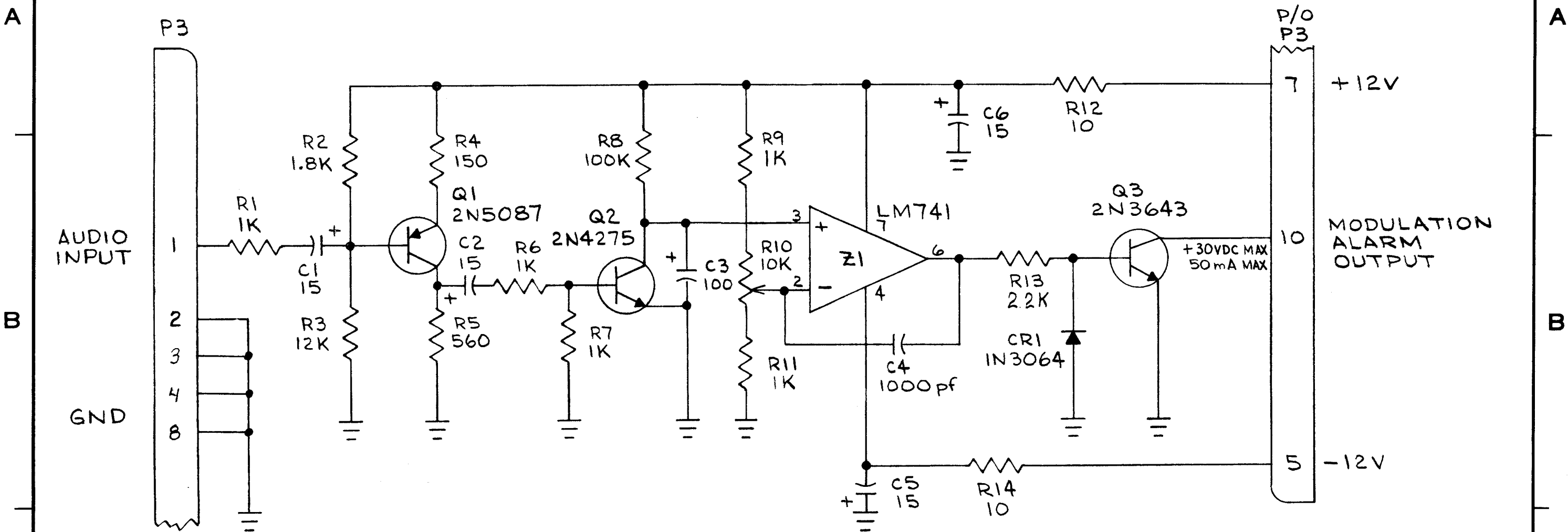

- NOTES; UNLESS OTHERWISE SPECIFIED:
1. RESISTORS - VALUES IN OHMS $\pm 5\%$, 1/4 WATT.
 2. CAPACITORS - VALUES IN MICROFARADS.
 3. INDUCTORS - VALUES IN MICROHENRYS $\pm 10\%$
 4. *FACTORY SELECT VALUE. TYPICAL VALUE SHOWN.
 5. VOLTAGES ARE DC CONDITIONS.

ITEM NO.	EN NO.	PART NO.	DESCRIPTION	REF. DES.
QTY PER ASSY				
LIST OF MATERIALS				
REMOVE ALL BURRS AND SHARP EDGES			DRAWN BY G.L.L.	DATE 11-24-75
TOLERANCES UNLESS OTHERWISE SPECIFIED			CHK. BY	TET TIME & FREQUENCY TECHNOLOGY INC. 3000 Olcott St., Santa Clara, California 95050 (408) 246-6365 TITLE SCHEMATIC MODULATION ALARM FIGURE 6-7 SIZE B DRAWING NO. 6601-1520 REV. A SCALE — SHT. 1 OF 1
.XX \pm			PROJ. ENG.	
.XXX \pm			MFG. ENG.	
ANGULAR \pm			APPD.	
DO NOT SCALE THIS PRINT			APPD.	
ECO NO.			APPD.	

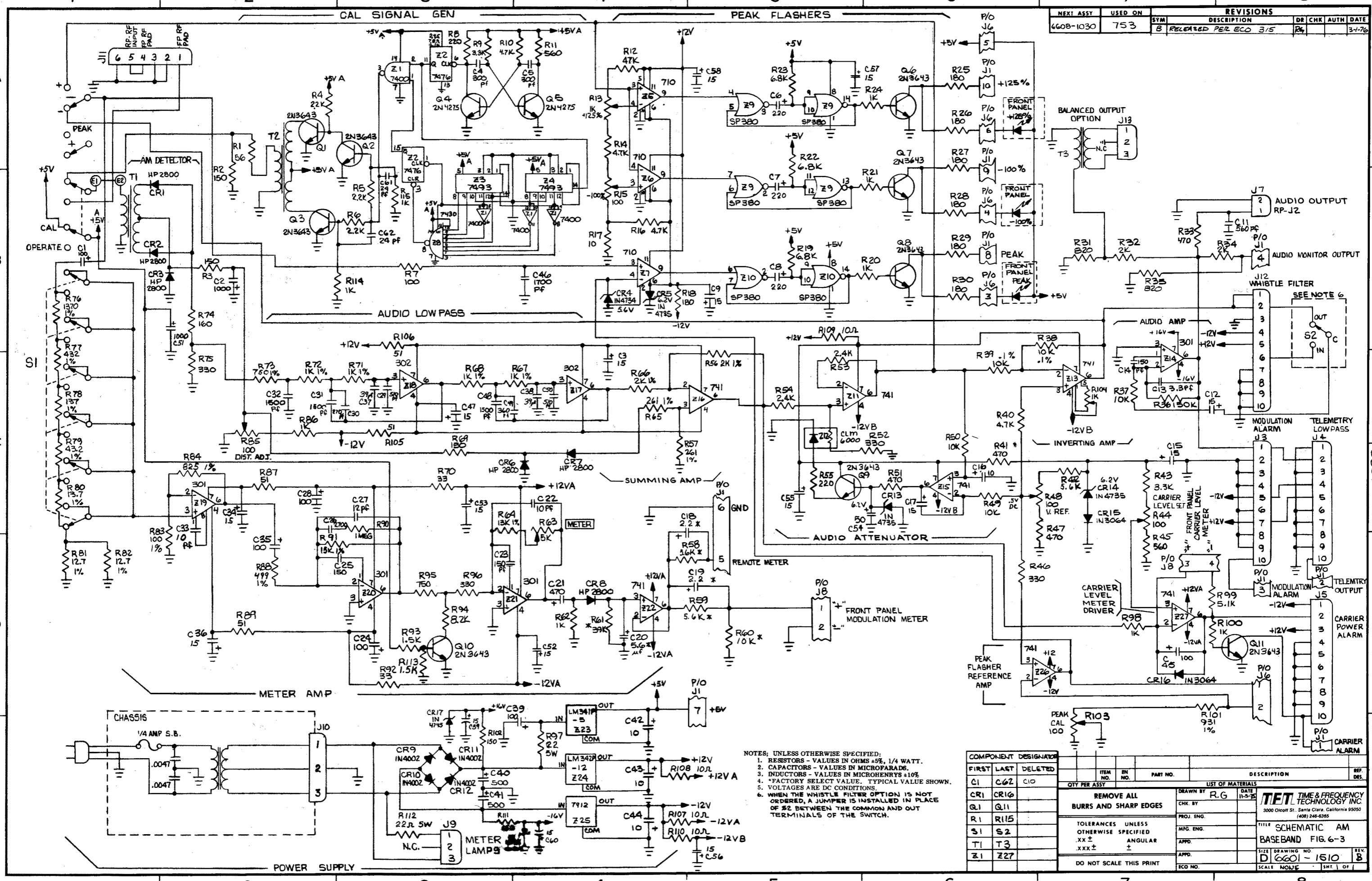

NEXT ASSY		USED ON		REVISIONS			
SYM	DESCRIPTION	DR	CHK	AUTH	DATE		
660B-1030	753	B	RELEASED	PER ECD	3/5	Rg	3-78

- NOTES: UNLESS OTHERWISE SPECIFIED:
- RESISTORS - VALUES IN OHMS $\pm 5\%$, 1/4 WATT.
 - CAPACITORS - VALUES IN MICROFARADS.
 - INDUCTORS - VALUES IN MICROHENRYS $\pm 10\%$.
 - FACTORY SELECT VALUE. TYPICAL VALUE SHOWN.
 - VOLTAGES ARE DC CONDITIONS.
 - WHEN THE WHISTLE FILTER OPTION IS NOT ORDERED, A JUMPER IS INSTALLED IN PLACE OF R2 BETWEEN THE COMMON AND OUT TERMINALS OF THE SWITCH.

COMPONENT DESIGNATOR			ITEM NO.		PART NO.		DESCRIPTION		REF DES.	
FIRST	LAST	DELETED	QTY PER ASSY	EN NO.						
C1	C62	C10								
CR1	CR16									
G1	Q11									
R1	R115									
S1	S2									
T1	T3									
Z1	Z27									

REMOVE ALL BURRS AND SHARP EDGES

TOLERANCES UNLESS OTHERWISE SPECIFIED
 .xx \pm ANGULAR
 .xxx \pm

DO NOT SCALE THIS PRINT

SCALE NONE

TET. TIME & FREQUENCY TECHNOLOGY INC.
 3000 Ocotill St., Santa Clara, California 95050
 (408) 246-6385

TITLE SCHEMATIC AM
 BASEBAND FIG. 6-3

SIZE DRAWING NO. D 6601-1510
 REV. B

NEXT ASSY		USED ON		REVISIONS			
ITEM NO.	EN. NO.	PART NO.	DESCRIPTION	DR	CHK	AUTH	DATE

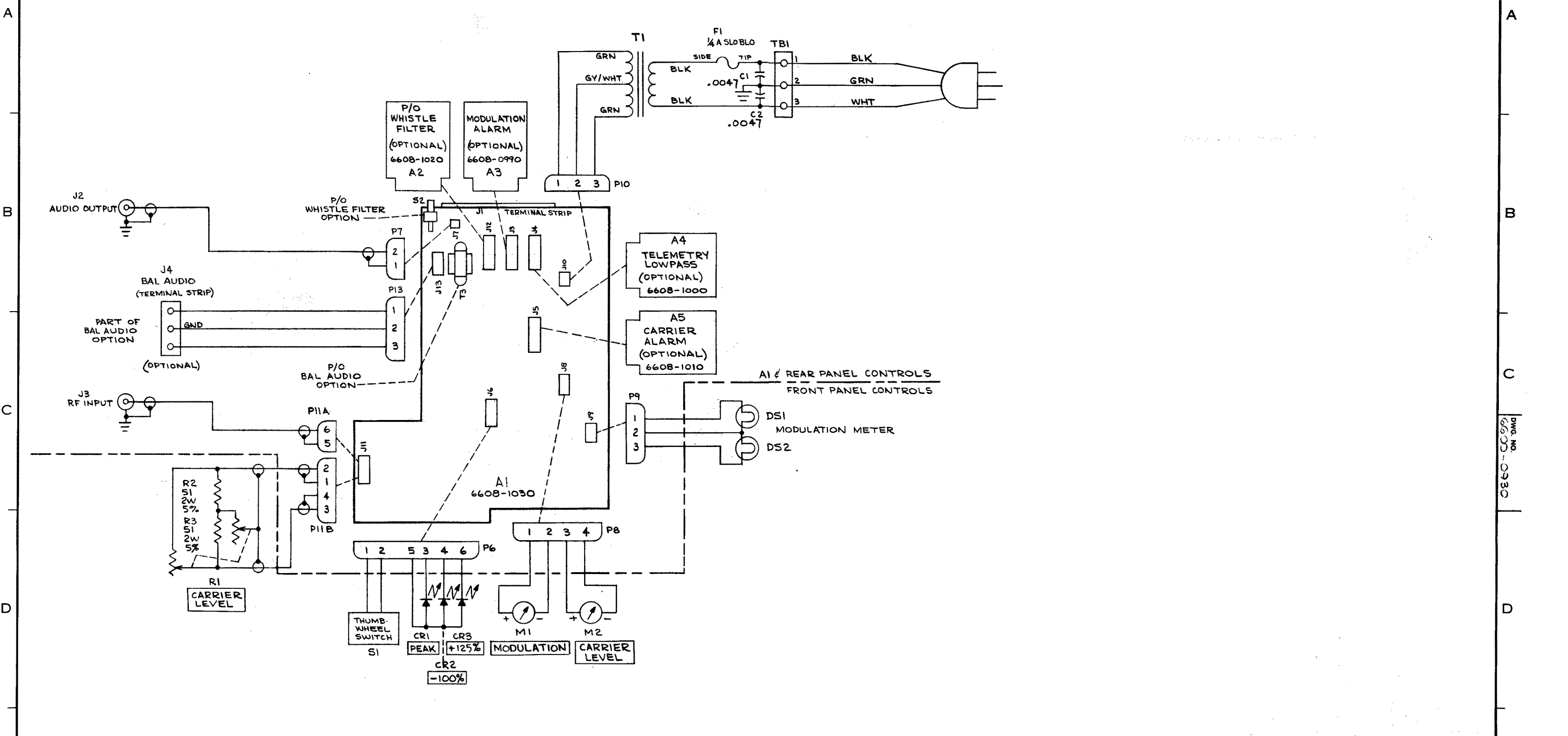

DWG. NO. 6600-0930

QTY PER ASSY	ITEM NO.	EN. NO.	PART NO.	DESCRIPTION	REF. DES.

REMOVE ALL BURRS AND SHARP EDGES	DRAWN BY G.L.L.	DATE 12-1-75	TET TIME & FREQUENCY TECHNOLOGY INC. 3000 Olcott St., Santa Clara, California 95050 (408) 246-6365 TITLE WIRING DIAGRAM AM MODULATION MON MODEL 753 FIG 6-2 SIZE DRAWING NO. REV D 6600-0930 A SCALE SHEET 1 OF 1
TOLERANCES UNLESS OTHERWISE SPECIFIED .XX ± ANGULAR .XXX ±	CHK. BY		
	PROJ. ENG.		
	MFG. ENG.		
DO NOT SCALE THIS PRINT	APPD.		