

# ***instructions***

FOR THE



## VINYL CLAD STEEL CABINET ACCESSORY

MODEL AE-15

The luggage-tan vinyl covering on your Heathkit Model AE-15 Cabinet will harmonize with any surroundings, and will match the appearance of other Heath hi-fi equipment. This Cabinet can

be installed on the Model AA-21D Transistor Stereo Amplifier or the Model AJ-43D Transistor Stereo Tuner. A screwdriver is the only tool you need to install the Cabinet.

### **PARTS LIST**

Check each part against the Parts List and read the Step-By-Step Procedure. Then complete the steps for your unit, either AA-21D Amplifier (Page 2) or AJ-43D Tuner (Page 3).

<u>PART No.</u>	<u>PARTS Per Kit</u>	<u>DESCRIPTION</u>
90-329	1	Cabinet
210-14	1	Bezel
250-8	6	#6 sheet metal screw
595-763	1	Instruction sheet

### **STEP-BY-STEP PROCEDURE**

The following instructions are presented in a logical step-by-step sequence to enable you to complete your Accessory Kit with the least possible confusion. Be sure to read each step all the way through before beginning the specified operation. Also read several steps ahead of the actual step being performed. This will fa-

miliarize you with the relationship of the subsequent operations. When the step is completed, check it off in the space provided. This is particularly important as it may prevent errors or omissions, especially if your work is interrupted.

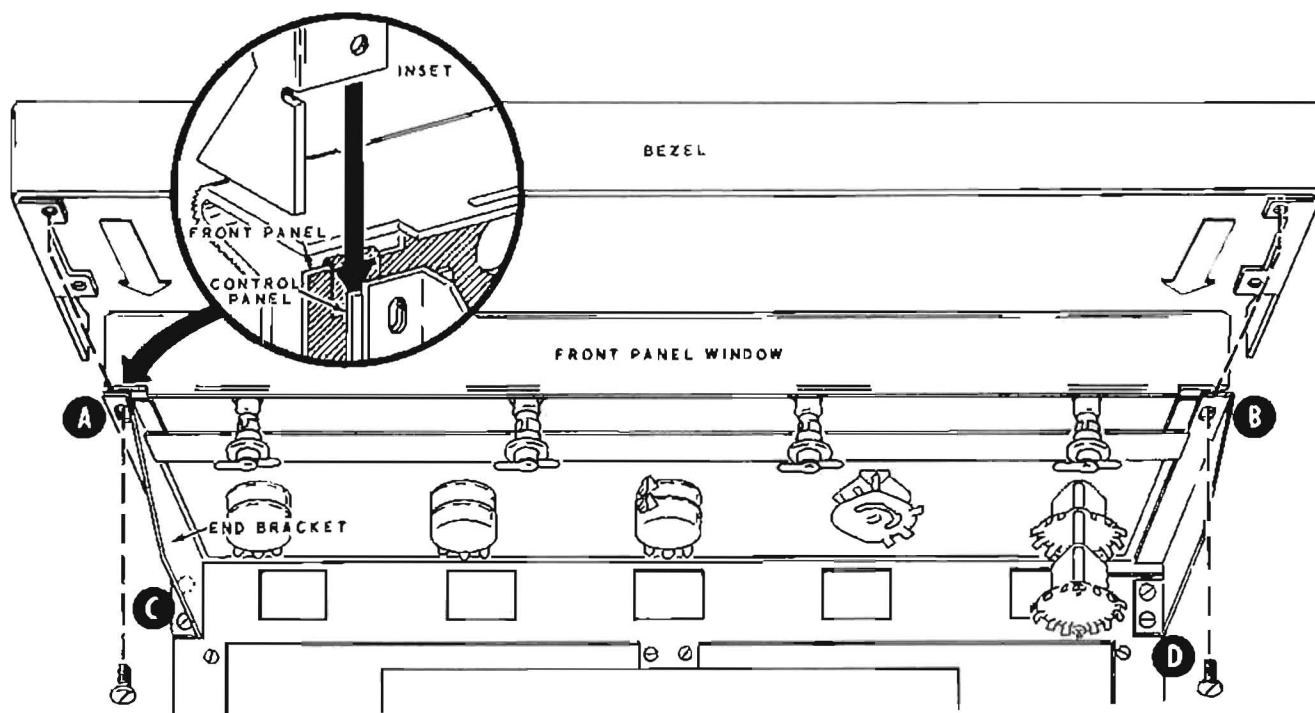

Figure 1

## AA-21D AMPLIFIER

Refer to Figure 1 for the following steps.

- ( ) Remove the screws from the front panel assembly at A and B. Save these two screws, since they will be used later.
- ( ) At the right-hand end bracket, loosen the two screws at C. Loosen these screws just enough to allow the end bracket to be moved on the chassis. Now pull the end bracket away from the front panel.
- ( ) Similarly, loosen the two screws at D on the left-hand end bracket. Now pull the end bracket away from the front panel.
- ( ) Install the bezel using only the two top holes at A and B. Use the two screws removed previously. Insert the tabs of the bezel between the front panel and the control panel as shown in the inset drawing on Figure 1. Be sure the bezel is down tight against the front panel window before tightening the screws.
- ( ) Push the right-hand end bracket until it fits tightly against the front panel assembly. Then tighten the two screws at C.
- ( ) Push the left-hand end bracket until it fits tightly against the front panel assembly and tighten the two screws at D.

Proceed to the Cabinet Installation section on Page 4.

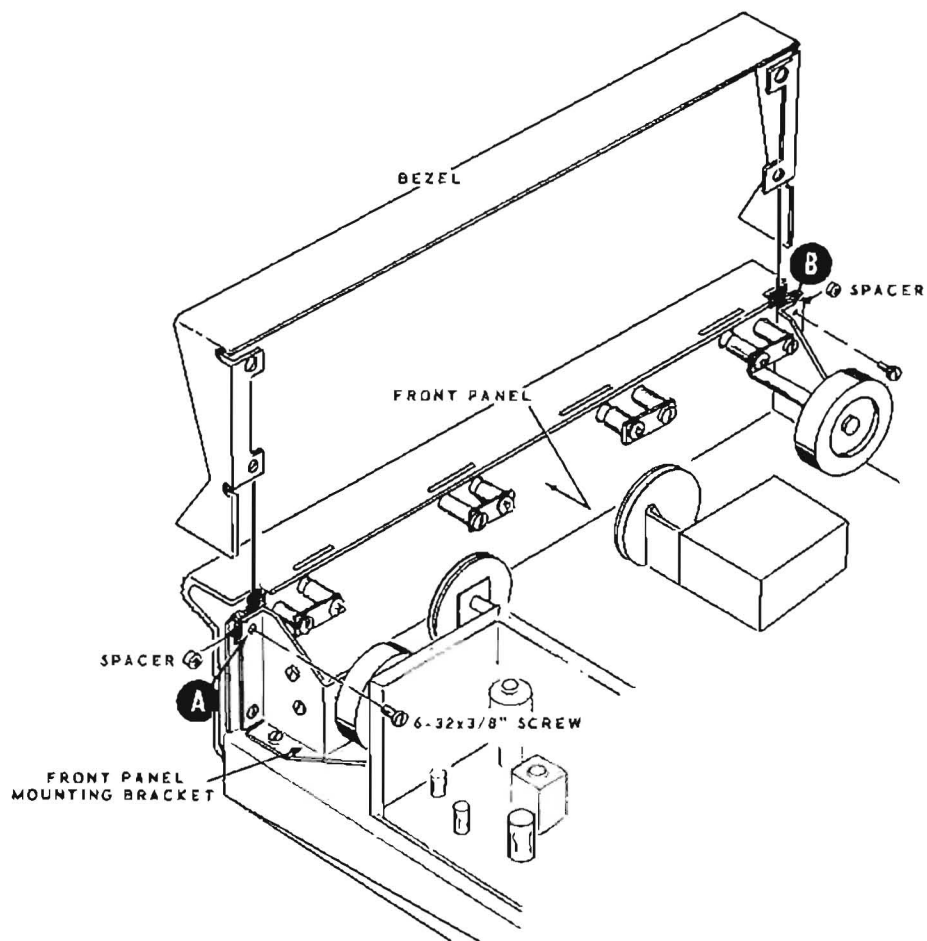

Figure 2

## AJ-43D TUNER

Refer to Figure 2 for the following steps.

- ( ) Remove the screw and spacer from the front panel assembly at A. The spacer is located between the front panel and the front panel mounting bracket. Discard the spacer but save the screw since it will be used later.
- ( ) Remove the screw and spacer from the front panel assembly at B. Discard the spacer and save the screw.

- ( ) Install the bezel using only the two top holes at A and B. Use the two screws removed previously. Insert the tabs of the bezel between the front panel and the front panel mounting brackets. Be sure the bezel is down tight against the dial window before tightening the screws.

Proceed to the Cabinet Installation section on Page 4.

## CABINET INSTALLATION

NOTE: The blue and white identification label shows the Model Number and Production Series Number of your Cabinet. Refer to these numbers in any communications with the Heath Company; this assures you that you will receive the most complete and up-to-date information in return.

Install the identification label in the following step.

- ( ) Carefully peel away the backing paper. Then press the identification label in place inside the Cabinet.
- ( ) Refer to Figure 3 and install the Cabinet on your unit (Amplifier or Tuner). Place a soft cloth on the work area for protection, then position the unit on its face and slide the Cabinet on from the rear. Use six #6 x 5/8" sheet metal screws.

This completes the installation of your Model AE-15 Vinyl Clad Steel Cabinet.

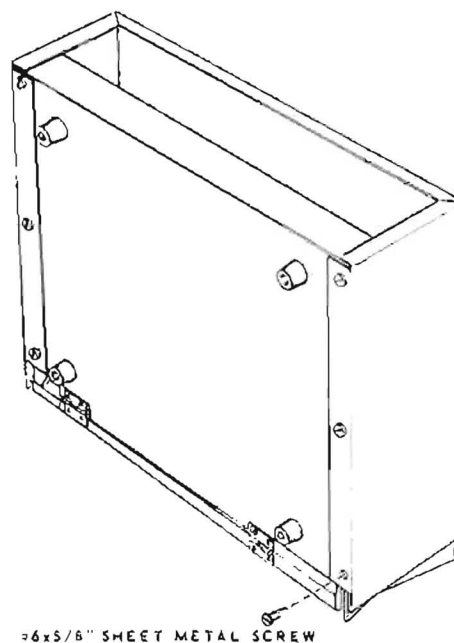

#6 x 5/8" SHEET METAL SCREW

Figure 3

### WARRANTY

Heath Company warrants that all Heathkit parts shall be free of all defects in materials and workmanship under normal use and service, and in fulfillment of such warranty Heath Company will, for a period of three months from the date of shipment, replace any part upon verification that it is defective.

The foregoing warranty shall apply only to the original buyer, and is and shall be in lieu of all other warranties, whether express or implied and of all other obligations or liabilities on the part of Heath Company and in no event shall Heath Company be liable for any anticipated profits, consequential damages, loss of time or other losses incurred by the buyer in connection with the purchase, assembly or operation of Heathkits or components thereof. No replacement shall be made of parts damaged by the buyer in the course of handling or assembling Heathkit equipment.

The foregoing warranty is completely void if corrosive solder or fluxes have been used in wiring the equipment. Heath Company will not replace or repair any equipment in which corrosive solder or fluxes have been used.

This warranty applies only to Heath equipment sold and shipped within the continental United States including APO and FPO shipments. Warranty replacement for Heathkit equipment outside the United States is on an f.o.b. factory basis. Contact the Heathkit authorized distributor in your country or write: Heath Company, International Division, Benton Harbor, Michigan, U.S.A.

HEATH COMPANY

All prices are subject to change without notice. The Heath Company reserves the right to discontinue instruments and to change specifications

at any time without incurring any obligation to incorporate new features in instruments previously sold.