

I N S T R U C T I O N B O O K

F O R

M O D E L 8 3 4 5 T E N U L I N E®

R F C O A X I A L A T T E N U A T O R

BIRD
Electronic Corporation

30303 Aurora Road, Cleveland, Ohio 44139-2794

Copyright 1987 by Bird Electronic Corporation

SAFETY PRECAUTIONS

The following are general safety precautions that are not necessarily related to any specific part or procedure and do not necessarily appear elsewhere in this publication.

Keep away from live circuits.

Operating personnel must at all times observe normal safety regulations. Do not attempt to replace parts or disconnect a RF transmission or any other high voltage line while power is applied. When working with high voltage always have someone present who is capable of rendering aid if necessary. Personnel working with or near high voltage should be familiar with modern methods of resuscitation.

The following will appear in the text of this publication and is shown here for emphasis.

```
*****
*                               C A U T I O N                               *
*                               *                                           *
* This equipment is designed for operation in a horizon- *
* tal position only, with mounting brackets down. Do not *
* operate in any other manner. *
*****
```

```
*****
*                               W A R N I N G                               *
*                               *                                           *
* The vent plug must be used at all times when the unit *
* is in operation or cooling. Failure to do this could *
* result in damage to the equipment and endanger the op- *
* erator's safety. *
*****
```

```
*****
*                               C A U T I O N                               *
*                               *                                           *
* Without the blowers operating, the continuous RF power *
* input is limited to 2000 watts. If the READY light is *
* off, do not exceed this value, regardless of the *
* selector switch position. *
*****
```

Continued

SAFETY PRECAUTIONS

* W A R N I N G *
* *
* Never attempt to disconnect the equipment from the *
* transmission line while RF power is being applied. *
* Leaking RF energy is a potential health hazard. *

* W A R N I N G *
* *
* Provide adequate ventilation and observe normal pre- *
* cautions when using dry cleaning solvents. Many dry *
* cleaning agent emit toxic fumes that may be harmful to *
* your health if inhaled. *

* C A U T I O N *
* *
* Use no coolant other than that provided by Bird Elec- *
* tronic Corporation. The use of any other dielectric *
* coolant will alter seriously the stated specifications. *

TABLE OF CONTENTS

	<u>Page</u>
SAFETY PRECAUTIONS	i
INTRODUCTION	
Purpose and Function.....	v
General Description.....	v
Connections.....	v
Performance Characteristics and Capabilities.....	v
Power and Utility Requirements.....	vi
Items Furnished.....	vi
SECTION I - INSTALLATION	
General.....	1
Venting.....	1
Thermoswitch.....	2
SECTION II - THEORY OF OPERATION	
General.....	6
SECTION III - OPERATING INSTRUCTIONS	
Use and Function of Controls.....	8
Initial Adjustment and Control Settings.....	8
Start-Up.....	8
Normal Operation.....	9
Operation Under Emergency, Adverse or Abnormal Conditions.....	9
Shutdown.....	10
SECTION IV - MAINTENANCE	
General.....	11
Cleaning.....	11
Inspection.....	13
Checking RF Section Assembly.....	13
Troubleshooting.....	14
Disassembly.....	15
Coolant.....	16
RF Connectors.....	16
Fan Replacement.....	17
Fuse Replacement and Repairs.....	18
SECTION V - PREPARATION FOR RESHIPMENT	
General.....	20

Continued

TABLE OF CONTENTS

	<u>Page</u>
SECTION VI - STORAGE	
General.....	21
SECTION VII - REPLACEMENT PARTS LIST	
Model 8345.....	22
ILLUSTRATIONS	
Model 8345 Dimensional Drawing.....	5
Thermoswitch Assembly (P/N 8890-017).....	4
Model 8345 Parts Designation Drawing.....	12
Blower Schematic of Model 8345 Attenuator.....	19
TABLES	
Specifications.....	vii

MODEL 8345 TENULINE® RF COAXIAL ATTENUATOR

INTRODUCTION

PURPOSE AND FUNCTION

The Model 8345 RF Attenuator is a low-reflection resistance network for use in the reduction of high power in controlled and known amounts for measurement purposes. It is an electrical "T" pad immersed in a liquid coolant, using principles employed in Bird TERMALINE® RF Load Resistors, which permit the use of large resistive elements at high frequencies while maintaining a low VSWR over a wide frequency range. The attenuator is designed to match the most commonly used 50 ohm transmission line systems.

GENERAL DESCRIPTION

The Model 8345 TENULINE® is a self-contained instrument with RF input power capability of 6000 watts, intended for forced air cooling in air of normal ambient temperatures. The attenuator unit is rectangular with rhombic shaped transverse cooling fins evenly spaced along its entire length. Attached to the front and rear faces of the blower assembly are mounting flanges. These flanges act as supports for free standing use or mounting brackets for optional fixed mounting. Mounting holes are provided for this purpose, see Installation, Section I.

CONNECTIONS

The RF input and output connectors are of the Bird "Quick-Change" design to permit rapid interchange of connector types. These "QC" connectors are located on the front and back of the unit. See Paragraph 4, of Maintenance, Section V for changing procedure.

PERFORMANCE CHARACTERISTICS AND CAPABILITIES

A system of resistive film-on-ceramic cylindrical resistors immersed in a heat resistant dielectric coolant constitutes the RF Section Assembly. The cooling fluid and the tapered input resistor housing provide the proper electrical characteristics for the coaxial line attenuation throughout the internal circuitry.

By convection, the cooling fluid carries the heat generated in the various resistor elements to the walls of the coolant housing. This housing is encased in a set of radiating fins which are attached to its outer surface. These radiating fin surfaces dissipate the heat of the coolant, by forced air from the blower unit, into surrounding air.

The unit may be used for isolation of power sources up to 6000 watts and for low level monitoring. The low power value obtained at the output of the attenuator could easily be read on an oscilloscope or terminated in a small RF load resistor.

POWER AND UTILITY REQUIREMENTS

This attenuator requires forced air cooling for a full six kilowatts power dissipation. Without forced air cooling the unit is capable of absorbing only two kilowatts of power. The blower fans that provide the forced air cooling operate on either 115V or 230V 50/60 hertz line power depending on model requirements.

ITEMS FURNISHED

The Model 8345 is normally equipped with a LC Female Connector on its input end and a Female N Connector on its output end. The connectors are of a "Quick-Change" design for convenient and easy interchange with any other AN type "QC" connectors. Available as an optional equipment item is an overload thermostwitch P/N 8890-017. This thermostwitch provides protection against burnout.

SPECIFICATIONS FOR MODEL 8345 TENULINE® RF COAXIAL ATTENUATOR

Impedance.....	50 ohms nominal
VSWR**.....	1.15 maximum dc-500MHz
Attenuation.....	30dB <u>+1/2</u> dB dc-500MHz
Connectors	
Input.....	Bird "QC" Type Female LC Normally Supplied
Output.....	Bird "QC" Type Female N Normally Supplied
Power Rating.....	6000W with blower running 2000W without blower running
Frequency Range.....	dc-500MHz
Dimensions.....	29"L x 9-1/2"W x 33-21/64"H (737 x 241 x 847mm)
Mounting Dimensions.....	27-23/32"L x 7"W (704 x 178mm)
Ambient Temperature.....	-40°C to +45°C (-40°F to +113°F)
Utility Power Requirements.....	115V ac 50/60Hz at 5A maximum 230V ac 50/60Hz at 2.5A maximum
Cooling Method.....	Forced air (Approximately 960 CFM)
Coolant Volume.....	7 Gallons (26.5 l) dielectric liquid
Weight.....	135 lbs. (61kg)
Operating Position.....	Horizontal only
Finish.....	Light navy grey baked enamel

** Using respective LC and N Connectors normally supplied.

SECTION I - INSTALLATION

1-1. GENERAL

```
*****
*                               C A U T I O N                               *
*                               *                                           *
* This equipment is designed for operation in a horizon- *
* tal position only, with mounting brackets down. Do not *
* operate in any other manner. *
*****
```

1-2. The Model 8345 Attenuator is intended ordinarily for stationary or fixed use. Because of the air supply requirement for the high flow cooling fans, about 960 CFM altogether, the air intake vent on the bottom must not be obstructed. Stand the attenuator on a flat surface with at least a 15 inch clearance on the sides or mount it over a clear opening of the same size as the fan enclosure, being sure air flow in and out of the equipment is unimpeded. The fans are protected by a perforated metal grille around the bottom.

1-3. There are mounting brackets on the front and rear flanges of the unit so the load may be fastened to a bench, etc., by means of four suitable fasteners. Four 3/8 inch elongated mounting holes, to be used with suitable screws up to 3/8 inch diameter, are arranged in a 7 inch x 27-23/32 inch rectangle (178 x 704mm).

1-4. VENTING

```
*****
*                               W A R N I N G                               *
*                               *                                           *
* The vent plug must be used at all times when the unit *
* is in operation or cooling. Failure to do this could *
* result in damage to the equipment and endanger the op- *
* erator's safety. *
*****
```

```
*****
*                               C A U T I O N                               *
*                               *                                           *
* Without the blowers operating the continuous RF power *
* input is limited to 2000 watts. If the READY light is *
* off, do not exceed this value, regardless of the *
* selector switch position. *
*****
```

1-5. Before placing the unit into operation remove the two shipping plugs at the top of the radiator, near the front, and substitute with the specially shielded vent plugs supplied. Use a 3/4 flat wrench for this purpose - do not lose the O-Ring seal.

1-6. These vent plugs open at a preset pressure to vent the tank and should be installed before the unit is put into operation. The use of these plugs also protects the filler openings against the intrusion of foreign material while venting the tank. The shipping plugs, with O-Ring seals, should replace the vent plugs whenever the unit is to be transported. Be sure to replace both plugs.

1-7. THERMOSWITCH

1-8. As a safety feature the attenuator may be provided with a thermoswitch assembly, P/N 8890-017. Installed on the back of the radiator, opposite end to the RF input, it prevents damage to the load resistor which could occur from accidental transmitter power overload or equipment malfunction. Being normally closed the thermoswitch opens at a maximum safe coolant temperature of +226°C (+439°F). When connected in a series with the transmitter interlock it will cut off the transmitter power if the load temperature exceeds this value. The assembly consists of a thermoswitch body, P/N 8890-015, with a coupling jack, P/N 2450-018, attached to it.

1-9. Where the Model 8345 TERMALINE® Load Resistor was originally supplied without a thermoswitch, the thermoswitch must be field installed. Follow the steps below:

- a. Replace the vent plugs with shipping plugs. Stand unit on its front end with connector end down. In this position there is no danger of coolant spillage. Support the radiator on its front face so the connector is not damaged.
- b. Using a 9/16 Allen wrench, remove the socket plug on the rear face of the radiator.
- c. Replace the plug with the thermoswitch. Use an acceptable pipe sealing compound sparingly on the external threads of the thermoswitch, only. Do not contaminate coolant with the pipe sealing compound. Observe closely for coolant leaks upon completion.

1-10. See Figure 1-1. and connect the thermoswitch as follows:

- a. Unscrew the larger knurled ring nut (A) at the lower end of the coupling jack assembly and pull off from the thermoswitch jack (B). Unscrew the small knurled cover fitting (C) from the base plug (D) of the connector to release the base.
- b. Thread interlock wires through the cable clamp (E) with washers (F) inside, and with its threaded fitting in place. Service the interlock wire with short tips, use spaghetti sleeves over the wire ends if needed, then securely solder the interlock leads to the lugs (G) of the connector base. Note - Be sure that the larger captive ring nut (A) is in place over the base plug (D) with the knurled end outward, towards face.
- c. Screw on the cover fitting (C) first, fasten the cable clamp (E) in place, and tighten the two yokescrews (H) on the cable. Push the plug back on the thermoswitch and tighten the knurled connecting

ring. Do not attempt to operate the equipment without the interlock attached.

Figure 1-1. Thermoswitch Assembly (P/N 8890-017).

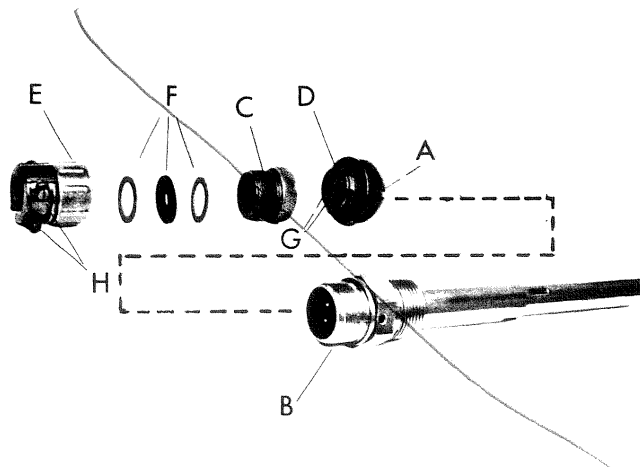
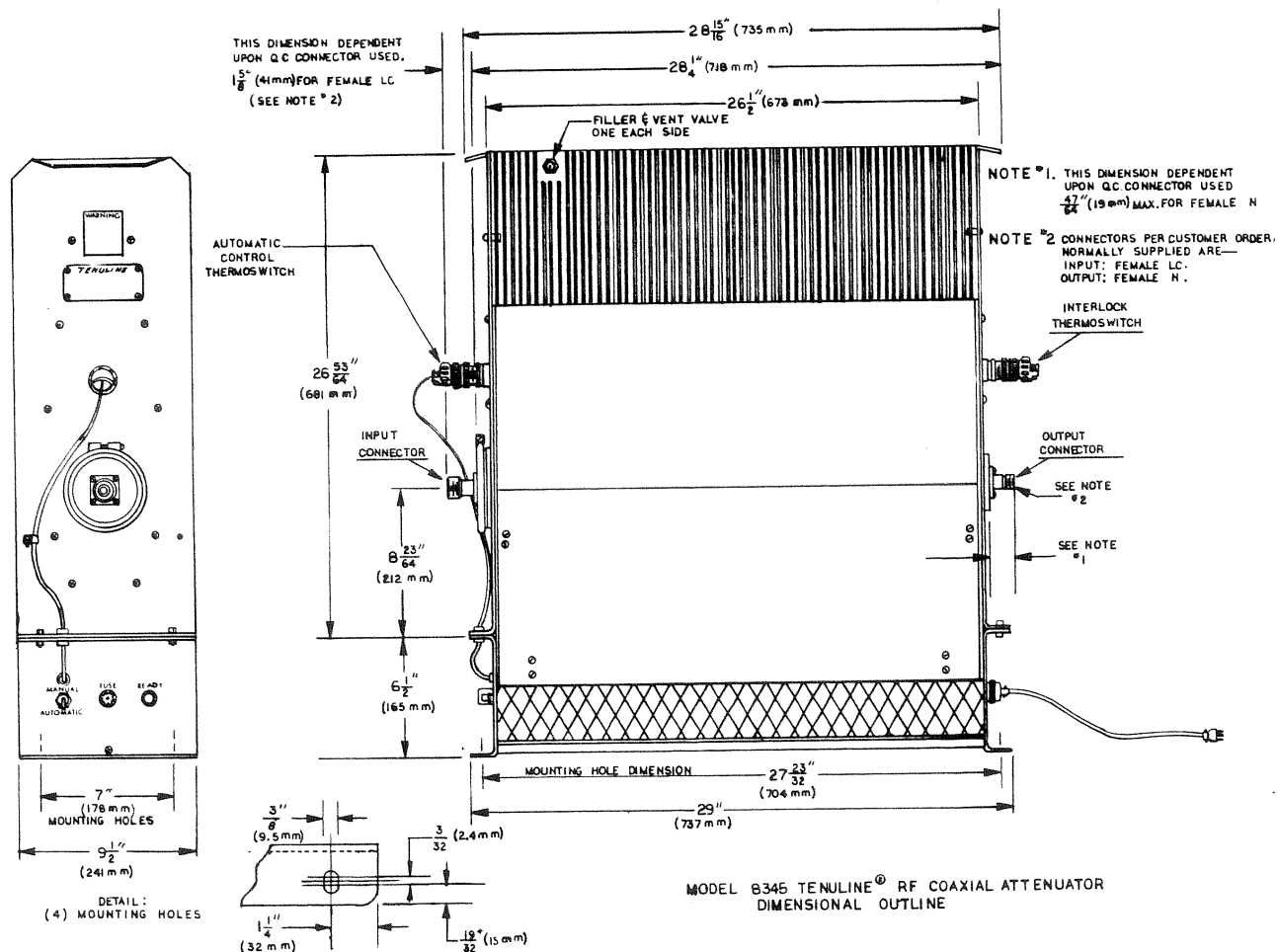

Figure 1-2. Model 8345 Dimensional Outline.



SECTION II - THEORY OF OPERATION

2-1. GENERAL

2-2. The Model 8345 Attenuator is a symmetrical "T" pad, with the power distribution on the legs being different. The value of the resistance on each leg varies therefore, according to the power it is to absorb. On the input resistance element, a proportionately larger resistor is of course required for its much greater power dissipation. A "T" configuration is used to provide equal input and output impedances for the 50 ohm transmission line attenuation.

2-3. The input resistor is joined to the "T" leg joint in an exponentially tapered housing to provide a linear reduction in surge impedance directly proportional to the distance along the resistor. The output resistor is enclosed in a housing designed to return to the characteristic impedance of 50 ohms. This arrangement produces a uniform and practically reflectionless attenuation characteristic over the stated frequencies of the attenuator.

2-4. This system of film-on-ceramic cylindrical resistors immersed in a heat resistant dielectric coolant constitutes the RF section assembly. The cooling fluid and the tapered input resistor housing provide the proper electrical characteristics for the coaxial line attenuation throughout the internal circuitry.

2-5. The dielectric coolant is carefully chosen for its desirable dielectric properties, to which the diameters of the resistors and housings are matched and for its high thermal stability characteristics. Expansion of the coolant, when power is applied to the attenuator, is accomplished by allowing the air, which is compressed by the expanding coolant, to escape through the vent plug located near the top and front face of the unit.

2-6. By convection, the cooling fluid carries the heat generated in the various resistor elements to the walls of the coolant housing. This housing is encased in a set of radiating fins which are attached to its outer surface. These radiating fin surfaces dissipate the heat of the coolant into the surrounding air.

2-7. The Model 8345 may be used for isolation of power sources up to 6000 watts and for low level monitoring. The low power value obtained at the output of the attenuator can easily be read on an oscilloscope or terminated in a small RF load resistor. Note - It must be clearly understood that at the full power and frequency capability of this model, see Specification for 8345 TENU LINE® Attenuator, only type LC, LT (Female or Male) or 7/8" EIA (air line) connectors will be adequate on the input end.

* C A U T I O N *
* *
* Without the blowers operating the continuous RF power *
* input is limited to 2000 watts. If the READY light is *
* off, do not exceed this value, regardless of the *
* selector switch position. *

2-8. The blower operates with a set of three axial fans placed beneath the heat exchanger unit. These fans are powered by a 115V or 230V ac power supply and controlled by a special thermosthwitch that is mounted in the dielectric medium. The fans will be operating when the extent of the RF loading is sufficient to require forced cooling. An over temperature thermosthwitch, P/N 8890-017, may be provided for use with this load to prevent damage from accidental transmitter power overload or possible load failure.

2-9. As input power is applied, the resistor generates heat which is absorbed by the adjacent coolant. By convection, the heated liquid flows through the holes in the coaxial shell to the walls of the fabricated radiator. The series of radiating fins efficiently transmits the heat of the dielectric coolant to the forced air flow. At the front of the radiator tank a control thermosthwitch is immersed in the coolant and turns on the blowers when the predetermined temperature of +100°C (+212°F) is reached. At the top of the dummy load are two vent plugs to relieve internal pressure resulting from expansion of the heated coolant.

SECTION III - OPERATING INSTRUCTIONS

3-1. USE AND FUNCTION OF CONTROLS

3-2. The Model 8345 Attenuator has only one operating control, the MANUAL/AUTOMATIC switch located on the base beneath the RF connector. The normal mode for this switch is automatic. The manual mode is provided so that the proper fan operation in the blower assembly can be verified before applying RF power to the attenuator.

3-3. A READY light that glows when the load is plugged into a 115V or 230V ac power line is located beside the switch as is the line fuse. The automatic control thermoswitch and the over temperature thermoswitch do not require operator attention to perform their function.

3-4. INITIAL ADJUSTMENT AND CONTROL SETTINGS

3-5. See that the unit is installed according to the procedures of Section I - Installation. Don't forget the connection of the transmitter interlock to the over temperature thermoswitch if so equipped. Plug the 20 foot power cord supplied with the equipment into an appropriate 50/60Hz power source. Note - The 230V ac cable, primarily intended for overseas use, is not provided with an outlet plug. The green wire is the ground. Connection to line power will illuminate the pilot READY light on the front panel. If it doesn't, check the fuse or consult Section IV - Maintenance.

3-6. With the READY light illuminated, test the operation of the fans by flipping the selector switch to the manual mode. Check that all three fans are running by testing for even airflow along the top of the radiator. If the operation is OK, then the attenuator is ready for RF power. For normal use return the selector switch to the automatic position. The automatic control thermoswitch, on the front of the radiator, is fully factory wired and preset for operation.

3-7. START-UP

```
*****
*                               C A U T I O N                               *
*                               *                                           *
* This equipment is designed for operation in a horizon- *
* tal position only, with mounting brackets down. Do not *
* operate in any other manner. *
*****
```

3-8. The attenuator is ready for RF connection as received. However, it may be useful to check the 50 ohm input resistance before using it, see Section IV - Maintenance.

3-9. Clean all the conductors and insulator surfaces on the transmission line face with a soft clean cloth and dry cleaning solvent. Use a self-drying nonresidue forming aerosol contact cleaner on the inaccessible portions of the connector.

3-10. Connect the attenuator to the transmitting equipment under test and to a suitable load with 50 ohm coaxial cabling (RG-8A/U, RG-213/U or equal) equipped with plugs which mate with the RF output connector of the attenuator. After the transmitter has been connected to the load, proceed according to the transmitter manufacturer's instructions. When reconnecting the antenna, it may become necessary to slightly readjust the transmitter due to possible differences in VSWR between the attenuator and the antenna system.

3-11. Make sure all connections are properly tightened; avoid the use of adapters and elbows whenever possible. The unit is now ready for the application of RF power.

3-12. NORMAL OPERATION

3-13. Note - The selector switch should be turned to automatic! When full RF power is applied to the load the heat produced by the resistor is absorbed by the dielectric coolant. When the coolant reaches the preset temperature of +100°C (+212°F) the control thermoswitch is actuated, turning on the blowers. Until the coolant temperature is lowered, usually by a reduction or shutdown of RF power, the blowers will continue to run. At lower power levels it is not unusual for the blowers to run intermittently. Be sure the READY light is on when the load is connected for standby. The light should remain on regardless of whether the blowers are in operation or have stopped automatically.

3-14. Proceed according to the instructions with the specific transmitting equipment involved.

3-15. OPERATION UNDER EMERGENCY, ADVERSE OR ABNORMAL CONDITIONS

```
*****
*                               C A U T I O N                               *
*                               *                                           *
* Without the blowers operating, the continuous RF power *
* input is limited to 2000 watts. If the READY light is *
* off, do not exceed this value, regardless of the *
* selector switch position. *
*****
```

3-16. The Model 8345 TENULINE® Attenuator is intended to absorb a maximum of 6000W continuously. It can absorb a moderately greater amount of power for short periods of time, provided that a sufficient interval is allowed in-between for the load to cool down to a safe temperature. Of course, if the load is equipped with an over temperature safety switch interlocked with the transmitter, it will be automatically protected from too large an overload or too long a period. Always use these units inside or in a covered area. They are not intended or recommended for outdoor use where they might be unprotected and exposed to the elements.

3-17. SHUTDOWN

```
*****  
*                               W A R N I N G                               *  
*                               *                                           *  
* Never attempt to disconnect the equipment from the *  
* transmission line while RF power is being applied. *  
* Leaking RF energy is a potential health hazard. *  
*****
```

3-18. An attenuator is a passive electronic device and therefore cannot be turned off. Power must be turned off at the source of RF energy instead. Do not disconnect the ac line power from the blower assembly at the same time the RF source is shutdown. Allow the fans to continue to run until the coolant temperature has been reduced to a safe level. The blower control thermoswitch will then automatically turn off the fans.

SECTION IV - MAINTENANCE

4-1. GENERAL

```
*****  
*                               W A R N I N G                               *  
*                               *                                           *  
* Provide adequate ventilation and observe normal pre-                 *  
* cautions when using dry cleaning solvents. Many dry                 *  
* cleaning agent emit toxic fumes that may be harmful to                 *  
* your health if inhaled.                                               *  
*****
```

4-2. The Model 8345 TENULINE® is rugged and essentially simple in design. It should require only nominal routine attention. These attenuators will operate for long periods of time if their power handling capabilities are not exceeded and blower operation is not restricted. The major requirements for care and preventive maintenance are covered in Paragraphs 4-3 - Cleaning and 4-9 - Inspection.

4-3. CLEANING

4-4. The outside surface of the load should be kept free of dust and dirt. The principal maintenance requirement of the operator will be to periodically clean the accumulated dust and lint off the radiator fins, fan blades and fan grille work. Excessive collection of dust and lint on the cooling fins will interfere with the efficient dissipation of heat and a collection of dust and dirt on the blower assembly will impede air flow. Clean the metallic contact surfaces and the teflon insulators of the connectors if they become dirty or grimy. Use a soft cloth and a dry cleaning solvent. The inaccessible internal parts can be cleaned with a self-drying, nonresidue forming aerosol type contact cleaner.

4-5. If any portions of the radiator are corroded or rusted, clean the area with a fine flint sandpaper and touch up with grey enamel.

4-6. When dirt and dust have accumulated in the radiator fin spaces or on the fan parts, they should be cleaned. Partial disassembly of the equipment will be required. Proceed as follows:

a. To remove the side baffles (Item 17) from the radiator assembly (Item 4) first unfasten the four #10-32 x 1/4 Phillips head screws (Item 21) from the radiator. These screws are unpainted and located on the front and rear faces of the radiator just below the crease on the side baffles.

b. Unfasten the four #10-32 x 3/8 Phillips head screws (Item 20) from the lower section of the side baffles. These are located just above the fan grille. The side baffles may now be removed, exposing the radiator fins for cleaning.

4-7. Vacuum the fins to remove the loose dirt and lint. If an oily residue remains, wipe it off with a soft cloth moistened with a suitable

detergent solution. Warm water and detergent should only be used with special care, being careful to keep them from all electrical parts. Clean the spaces between the fins to fully remove all the dirt and grime.

Figure 4-1. Model 8345 Parts Designation Drawing.

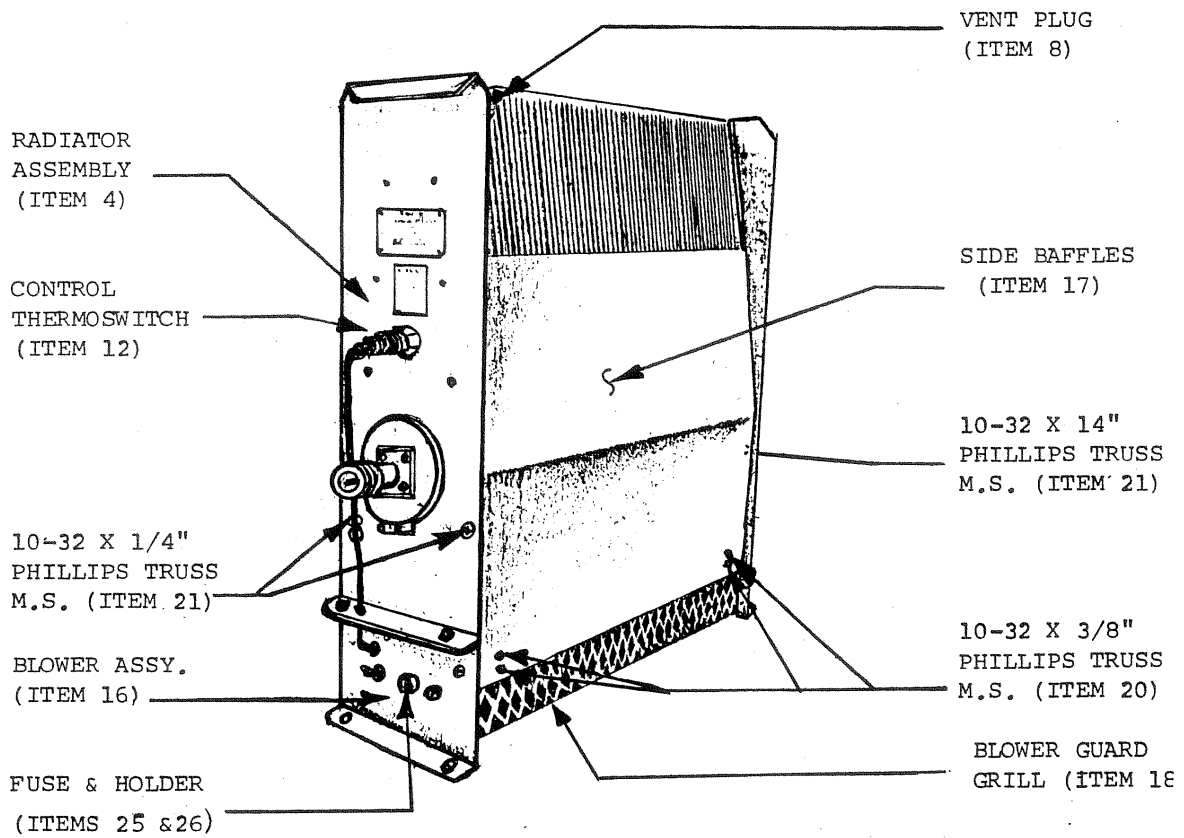

4-8. To check the fans for cleanliness, spring out the base grille so that its upper flanges come free from the housing. Pull down to remove. Clean the fans with care, using a soft cloth moistened with a suitable detergent solution. Note - Take care to use only a solution that will not attack the plastic parts of the fan. Check the condition of both sides of the fan blades and the venturi. Reassemble the equipment by reversing the above procedure. Note - It is not necessary to lubricate the fans as they have permanently lubricated, sealed ball bearings.

4-9. INSPECTION

4-10. With the rugged and simple construction of the load, periodic inspection will be necessary only at about six month intervals. Inspection should include the items listed below:

a. Oil Leakage - Check for coolant oil seepage around the radiator tank, particularly at the front and back around the underside of the clamping band. If leakage is observed, see 4-13, Troubleshooting and check tightness of the clamping band. If necessary, tighten the screw on the clamping band. If leakage continues the O-Ring seal may have to be replaced.

b. Cleanliness - Check for the accumulation of dust and dirt on the cooling fins and the blower assembly, see 4-3, Cleaning.

c. Inspect the load for completeness and general condition of the equipment.

d. Troubleshooting Chart, Paragraph 4-13, lists the commonly encountered problems, their possible causes and remedies. Use this chart as a guide when analyzing symptoms.

4-11. CHECKING RF SECTION ASSEMBLY

4-12. Accurate measurement of the dc resistance between the input to ground, output to ground, and input to output will provide a good check of the condition of the attenuator. For these measurements, a resistance bridge, or an ohmmeter with an accuracy of 1% or better at 50 ohms should be used. Use low resistance leads, preferably a short piece of 50 ohm cable (RG-8A/U or RG-9B/U) attached to Male plugs which mate with the Female connectors on the attenuator. When the resistance of the equipment is checked at room temperature, the measured readings should be within ± 2 ohms of their nominal resistance values commonly, 93.7 ohms input to output and 50 ohms from either end to ground. It is recommended that for reference purposes, these resistance values should be measured upon receipt of the attenuator and then checked periodically thereafter.

4-13. TROUBLESHOOTING

PROBLEM	POSSIBLE CAUSE	REMEDY
Leakage of Coolant Oil Around Clamping Band or Output Connector	Clamping band not tight	Tighten slightly with a screwdriver.
	Faulty O-Ring (input or output)	Replace per Paragraph 4-15.
Excessive Overheating of the Radiator	Transmitter power too high	Reduce transmitter power.
	Faulty RF section assembly	Replace per Paragraph 4-15.
	Coolant oil level too low	Add more coolant oil to the radiator per Paragraph 4-18.
	Blower assembly not functioning properly	Check blower assembly for possible blockage of vents or jamming of fans.
	Fan motor burn out	Replace fan. Note - fan motors have a built-in thermostwitch for shutdown in case of overheating.
	No ac power to fan motors	Check if READY light is on, possible power failure or unplugged power cable.
	No ac power to fan motors	Check power cord for continuity. Check fuse.
High or Low Resistance Values Per Paragraph 4-12	Defective control thermostwitch	Replace thermostwitch.
	Faulty RF input connector	Replace per Paragraph 4-21.
	Loose RF input connector	Tighten as necessary.
	Faulty RF section assembly	Replace per Paragraph 4-15.

4-14. DISASSEMBLY

```
*****
*                               C A U T I O N                               *
*                               *                                           *
* Use no other coolant than that provided by Bird Elec- *
* tronic Corporation. The use of any other dielectric *
* coolant will alter seriously the stated specifications. *
*****
```

4-15. To replace the load resistor assembly use the following procedure:

a. Remove the Rf output connector from the rear of the unit to prevent damaging it. See Paragraph 4-20 for removal instructions.

b. Replace the two vent plugs at the top front of the radiator with the shipping plugs. Place the unit on a low table or other work surface.

c. Carefully raise the unit by its front handle and base foot until it is tipped up on its back. It will be necessary to place the unit on blocks so that the interlock thermosthich handle or base foot is not touching the work surface. The back face of the unit should be parallel with the work surface.

Note - The unit must be drained of dielectric coolant. Do not try to remove the RF assembly while unit is full of coolant. The output assembly is part of the RF assembly and comes out with the main assembly leaving an opening in the back of the heat exchanger.

d. Disconnect the control thermosthich by unscrewing the knurled retaining nut and pulling the connection apart.

e. Using an appropriate wrench, unscrew the thermosthich from the face of the heat exchanger. Removing this thermosthich exposes the coolant inside. It is through this opening that the heat exchanger is drained of coolant.

f. Drainage of the coolant is best accomplished by using a small motorized pump. If a pump is not available, siphoning off the coolant will be slow but will do just as well. Pour the coolant into clean five gallon containers to be stored for use at reassembly.

g. When the unit is completely drained remove the V-band clamp from around the front (input) connector assembly by loosening the #10-32 holding screw sufficiently to slip the band off.

h. Carefully work the RF section assembly loose using the LC input connector as a grip, and lift it straight out of the radiator tank. There will be some initial resistance as the O-Ring seal around the rear connector assembly comes loose from the housing. This operation may be done with the load standing vertically or setting horizontal on the work surface.

Note - When removing the RF section from the tank it is likely that some coolant may be trapped in the rear cylinder assembly. Carefully turn the RF section over to drain any residue.

i. With the RF assembly removed from the tank, it is not subject to further disassembly by field maintenance. A defective unit should be returned to the factor for repair or replaced in its entirety. Consult with the factory.

j. To replace the RF assembly, simply reverse the disassembly procedure. If a new RF assembly is to be installed or if the output O-Ring seal has been replaced, lubricate the O-Ring with a little dielectric coolant or any silicone lubricant before installing the RF section. Do not use O-Rings if they are no longer soft and pliable or show signs of surface cracks. Refill the heat exchanger tank to the proper level through the fan control thermostat opening in the tank. See Paragraph 4-17.

4-16. COOLANT

4-17. Under normal operating conditions, the level of the dielectric coolant in the unit should remain constant even after prolonged usage. As mentioned in Paragraph 4-10, occasionally inspect the lower portion of the clamping band on the front of the tank and also around the output connector on the rear face for signs of possible coolant leakage. If any leakage is found at the front of the unit, first, try to tighten the clamping band screw. If the leakage persists, which is a very unusual condition, it will be necessary to replace the resistor housing O-Ring seal. If the rear seal is leaking, which is highly improbable, it will definitely have to be replaced. In either case, the unit will have to be drained and the RF assembly removed as describe in Paragraph 4-15. Replace the output or input seal O-Ring as necessary before reassembly. Be sure the O-Rings are in good condition. They should be free of twists and positioned evenly all around.

4-18. Replace the coolant through the thermoswitch opening after the RF assembly has been replace. Fill the unit to within 4 to 4 1/2 inches below the thermoswitch opening surface when the liquid is at an ambient temperature of 72°F (22°C). The unit is factory filled to this level with 7 gallons (26.5 liter) of a specially selected dielectric liquid, P/N 5-1070-3. NO OTHER COOLANT MAY BE USED.

4-19. When the coolant is heated, thermal expansion will cause an increase in the internal tank pressure. Vent plugs are provided at the top of the finned tank heat exchanger to relieve this pressure and protect the tank openings from the possible intrusion of dust, dirt or other contaminants. Be sure to replace these vent plugs on completion of any repair work.

4-20. RF CONNECTORS

4-21. The input and output connectors on the Model 8345 are of a special Bird "Quick-Change" design which permits easy replacement or change with the use of only a screwdriver. This process does not in any way interfere with the essential coaxial continuity of the attenuator's RF input, output or the coolant seals. To replace a connector, proceed with the steps that follow:

- a. Remove the four 8-32 x 5/16 inch round head machine screws from the corners of the connector's flange.
- b. Pull the connector straight out of its socket.
- c. To replace the connector, reverse the procedure above. Be sure the projecting center pin of the connector is carefully engaged in the metering socket of the load resistor before pushing it firmly home.

4-22. FAN REPLACEMENT

4-23. If a fan unit (Item 22) should fail and require replacement, first notice that each fan assembly is different, not only in voltage requirements, i.e. 115V or 230V ac, but also hook up wire length. Each fan is individually serviced for its position in the blower housing, A for the front position, B for the mid position, and C at the rear nearest the terminal block. When ordering a replacement fan, be sure to give the correct part number to account for voltage requirements and fan position. The fan will be provided with leads of the proper length with lugs for direct attachment to the terminal block. Use the following disassembly procedure to replace the fans.

- a. First remove the side baffle panels. This is accomplished by removing the two 10-32 x 1/4 inch Phillips truss head screws on the front panel and two on the rear panel. These are the screws that are not painted. Also remove the four 10-32 x 3/8 inch Phillips truss head screws on each side panel. These are located near the bottom edge of the panel two near the front and two near the back. When all these screws are removed, the side panels will come right off.
- b. Loosen the coupling nut on the control thermoswitch and disconnect. The control thermoswitch lead will not have to be disconnected from the blower assembly, yet enough slack will be required to separate the heat exchanger front the blower assembly.
- c. Remove the four 5/16 - 18 screw and nut sets from the mounting flanges that secure the attenuator to the blower assembly. The attenuator will lift right off the blower assembly restricted only by the control thermoswitch lead. Set the attenuator to the side of the blower assembly.
- d. The blowers are now exposed and unobstructed for easy removal. Determine the defective fan to be removed and locate its leads and where they are connected to the terminal strip. The fans will be connected to terminals either 2 or 3 and 5 or 6.
- e. Disconnect the wires from the terminal strip and free them back to the fan. One or two cable clamps, as the case may be, may have to be loosened in order to free the wires.
- f. Unscrew the 10-32 screw and nut sets that secure the fan in place. These are located in each of the four corners of the fan housing. A screwdriver and an 3/8 inch open end wrench are the only

tools that will be required. Set the screw and nut set aside to be used when reinstalling the fan. After the screw and nut sets are removed, the fan will come right out.

g. When reinstalling the fan, simply reverse the procedure above. be sure to reinstall the fan to the same position and right side up. Before completing reassembly of the unit, check the blower assembly for correct operation.

4-24. FUSE REPLACEMENT AND REPAIRS

4-25. The components in the Model 8345 equipment are for the most part rugged and simple, and should give long term service without replacement. If such replacement becomes necessary, proceed as outlined in 4-14, Disassembly. The only part susceptible to failure and replacement is the 5 amp fuse (Item 26) located in its holder on the center of the blower housing front panel. If the "READY" light does not illuminate, check the line power. If the line power is as it should be, then check the condition of the fuse. The fuse is removed from the fuse holder (Item 25) by pushing in and turning the fuse knob 1/4 turn counterclockwise, then pulling outwards. If the fuse is burned out, check the circuitry and components for shorts, also check the fans to be sure that the blades are moving freely. A schematic diagram of the blower wiring is given in Figure 4-2. Replace the fuse with a 3AG-5A, 1/4 inch glass type as original installed. Insert the fuse into the knob of the fuse holder. Replace the fuse, with the knob, into the fuse holder pressing in firmly and turning the knob one quarter turn clockwise. Do not use a fuse of a higher rating than the 5 amp supplied when replacing.

4-26. If after replacing the fuse the fans still do not function, or if the fuse burns out again, it may be necessary to return the blower assembly, Item 16, to the factory. Consult with the factor.

4-27. Replacement of the control thermoswitch or over temperature thermoswitch may be accomplished similar to the procedure of Paragraph 1-9. The other components, switch and pilot are electrical items of common types and may be easily serviced by anyone accustomed to the usual procedures for this type of equipment.

4-28. If there should be any other repairs beyond what is covered in this instruction book, the unit should be returned to the factory for service.

Figure 4-2. Blower Schematic of Model 8345 Attenuator.

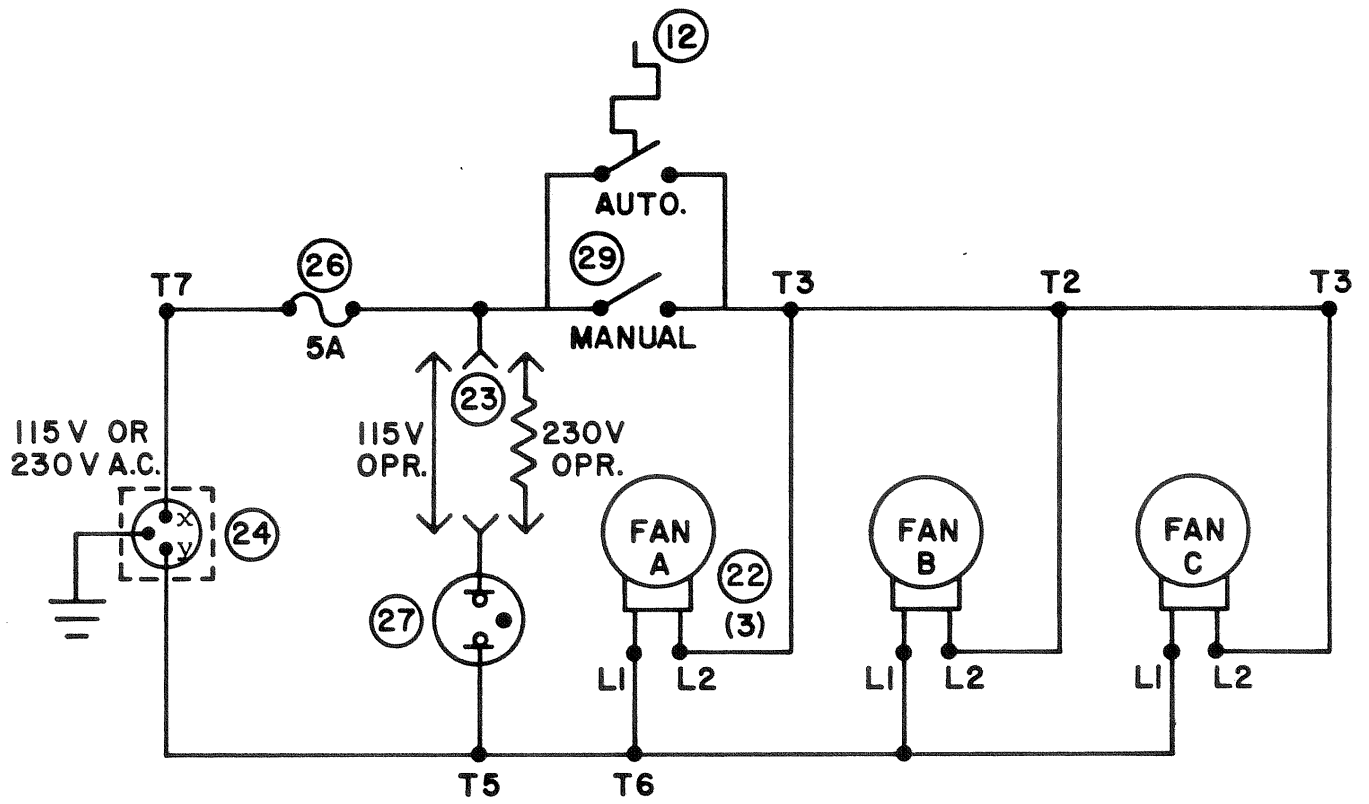

SECTION V - PREPARATION FOR RESHIPMENT

5-1. GENERAL

5-2. First remove the two vent plugs at the top of the radiator, near the front, and replace them with the two shipping plugs supplied. Make sure to use the O-Ring seals supplied for each vent opening to prevent leakage of the coolant.

5-3. Wrap the RF connector with padding and tape securely in place. Pack and brace the load in a suitable shipping container, a sturdy wooden crate is recommended. It is not necessary to remove the dielectric coolant before shipping.

SECTION VI - STORAGE

6-1. GENERAL

6-2. No special preparations for storage are necessary other than to cover the equipment to keep out dust and dirt. Store this unit in a dry and dust free environment where the ambient temperature will remain with the -40°C to +45°C (-40°F to +113°F) working range of the load.

SECTION VII - REPLACEMENT PARTS LIST

7-1. MODEL 8345

<u>ITEM</u>	<u>QUANTITY</u>	<u>DESCRIPTION</u>	<u>PART NUMBER</u>
1	1	RF Load Resistor Assembly	8345-007
2	1	Assembly, Clamping Band (2430-043 & Screw)	2430-055
3	1	O-Ring, Vent & Shipping Plug Seal	5-504
4	1	Assembly, Radiator	8345-002
5	1	Radiator, Shell Unit Only	8345-003
6	1	Assembly, Front Plate	8921-012
7	1	Assembly, Rear Plate	8345-011
8	2	Plug, Vent	2450-094
9	2	Plug, Shipping	2450-049
10	1	Thermoswitch Assembly, Over temperature	8890-017
11	1	Body, Thermoswitch (Goes with Item 10)	8890-015
12	1	Thermoswitch Assembly, Control	8896-013
13	1	Assembly, Body (Goes with Item 12)	2450-086
14	1	Cable, Serviced - Blower Control	8931-114
15	2	Jack, Thermoswitch Connector (Goes with Items 10 and 12)	2450-018
16	1	Blower Assembly, Base	8931-102-1
17	2	Panel Assembly, Side	8931-103
18	1	Guard, Grille - Blower Base	8931-106
19	4	"U" Strip, Baffle Edge - 20 5/8"L	5-300-2
20	8	#10-32 x 3/8" Phillips Truss Machine Screw Panel Grille	Standard
21	4	#10-32 x 1/4" Phillips Truss Machine Screw Radiator End to Panel Bracket	Standard

Continued

7-1. MODEL 8345

ITEM	QUANTITY	DESCRIPTION	PART NUMBER
22	3	Fan, Blower Only	
		115V - 50/60 Hz, 85W (340CFM)	5-740-1
		230V - 50/60 Hz, 85W (340CFM)	5-740-2
	1	Fan with Servicing for	
		Front Position 115V	8931-127-1
		Middle Position 115V	8931-128-1
		Rear Position 115V	8931-129-1
		Front Position 230V	8931-127-2
		Middle Position 230V	8931-128-2
		Rear Position 230V	8931-129-2
23	1	Resistor Dropping	
		115V	None
		230V	5-097-8
24	1	Base, Midget Socket	5-748
25	1	Holder, Fuse	5-547
26	1	Fuse, 3AG, 5A	5-342-5
27	1	READY Light, Indicator	5-860
28	1	Strip, Terminal - 7 Post	5-048-7
30	16	#10-32 x 7/8 Truss Head Machine Screw With Nut & Washer	Standard
31	6 2/3 gallons (25.3 liter)	Coolant	5-1070-3 (5 Gallon Container)
32	1	Cable, AC Line Supply	
		115V	8950-023-1
		230V	8950-023-2
33	1	"QC" Connector	*See Below

Continued

7-1. MODEL 8345

*Available "QC" Type Connectors

Input Only

LC-Female	4240-031**	LT-Female	4240-018
LC-Male	4240-025	LT-Male	4240-012
	7/8" EIA Air Line	4240-002	

Output Only

N-Female	4240-062	C-Female	4240-100
N-Male	4240-063	C-Male	4240-110
HN-Female	4240-268	UHF-Female (SO-239)	4240-050
HN-Male	4240-278	UHF-Male (PL-259)	4240-179

*Optional Items

**Normally Supplied