

# MODEL AF315 AM RECEIVER/MONITOR OPERATION MANUAL

## GENERAL:

The Model AF315 is a precision AM (mono) broadcast receiver designed for EAS or other monitoring purposes. The receiver is PLL (phase lock loop) controlled. The frequency of operation is selected using internal DIP switch combinations. A continuous LINE receiver output (adjustable) is provided as well as a SPKR audio output for driving an 8 Ohm monitor speaker. The receiver is designed for the most demanding sensitivity, distortion, and signal to noise requirements. There are Carrier and Modulation indicators. Balanced audio output as well as Carrier Level operated Relay outputs are available as an option.



**AF315 AM Receiver:** Front View;  
Rear View (Relay Optional )(DIN)

The receiver circuit board has 10 VDC automotive style regulators. Input power is derived from wall mounted power converters (115 VAC to 12VDC, 300mA) or other 12 VDC sources. The receiver is housed in a metal case or configured as one receiver in the AFC3 multiple receiver rack mount chassis.

## SPECIFICATIONS:

Tuning Range:	530 to 1750 KHz, selected by internal DIP switch.
Antenna Input:	"F" connector
Sensitivity:	3.0 micro Volt with 80% modulation, 20 dB S/N
Selectivity:	60 dB (+/- 10 kHz)
Audio Response:	3700Hz (-10dB); (other audio bandwidth filters available)
Distortion:	<1.0% THD at 80% Mod
Maximum Input Level:	1.0 V @ 80% Mod for <1% THD
S/N @ 80% Modulation:	48 dB @ 1mV 50 dB @ 10 mV
LINE Output:	1.1 VP into 600 Ohms (Adjustable) (0dBm +/- 6dB)

## POWER REQUIREMENTS:

115 VAC to 12VDC, 300mA  
(converter provided)

## CONTROLS:

VOL Control:	Rear Panel Mount Screwdriver adjust
Carrier Level Relay: LINE Level	Internal Adjust (RV2) Internal Adjust (RV3)

## INDICATORS:

Carrier:	Front Panel mount LED
Modulation:	Front Panel mount LED
Power:	Front Panel mount LED

## SIZE:

Metal Case Size: 6.0"W x 8"D x 1 3/4"H  
Weight 1.5 lbs

## OPTIONS AVAILABLE:

Option -MF 19" front panel rack mount (1 3/4")  
Option -B Balanced LINE output via DIN connector  
Option -R Carrier operated Relay via DIN connector  
AF315 can be selected as one of the receivers in the AFC3 package (options B & R are standard in the AFC3).

### DAYTON INDUSTRIAL CORPORATION

2237 Industrial Blvd

Sarasota, Florida 34234

Telephone: (941) 351-4454 Fax: (941) 351-6081

Visit our website at [www.daytonindustrial.com](http://www.daytonindustrial.com)

**SETTING THE FREQUENCY OF OPERATION:**

The first item to be performed is to set the receiver frequency of operation. The receiver is a PLL design, the frequency is set by a series of switches, arranged as internal DIP switches, marked SW1 and SW2. Access to the switches is by removing the top cover of the receiver. Locate SW1 and SW2 on the circuit board (refer to parts layout diagram on page 4). The switches are marked indicating the “on” position. The “on” position for a switch is the logical “1”, and the “off” position is the logical “0” for the receiver microcontroller. Please note that SW2 positions R0 and R1 are always to be in the “0” or “off” position.

The frequency of operation is set by the positions of switches D0, D1,...through...D13. Note that the switch “on” position is always the position towards the microcontroller, IC10. Table 1.0 lists the switch position for each switch corresponding to the desired frequency of operation. Set the switches according to Table 1.0 for the desired operating frequency.

**CONNECTORS/CONTROLS (REAR):**

After setting the frequency, the next item is to make connections at the receiver rear panel. The connectors are shown in Figure 1.0 for the individual unit chassis. Similar connections are made on the rear panel of the AFC3 if the AF315 is one receiver in the AFC3 chassis.

**FIGURE 1.0**

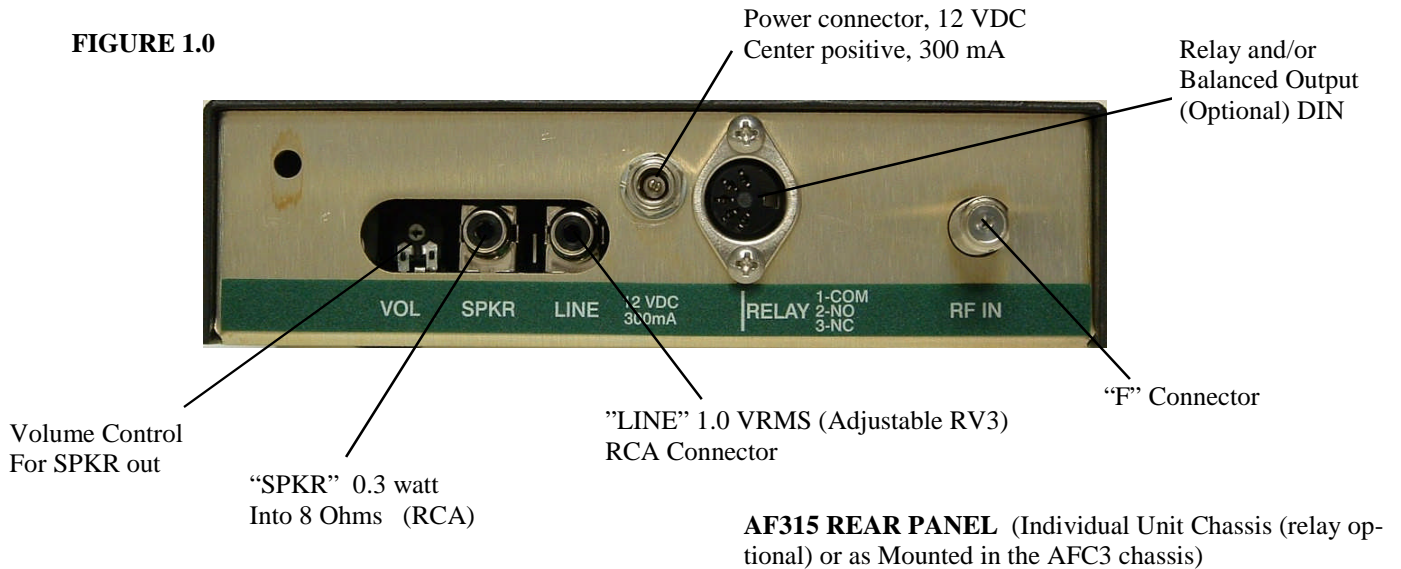

**AF315 REAR PANEL** (Individual Unit Chassis (relay optional) or as Mounted in the AFC3 chassis)

**RF (530 to 1750 KHz), RF IN:** The RF connector is an “F” connector. The input resistance is 100K Ohms. The input capacitance is 22 pF. The receiver is designed to operate from a whip antenna.

**LINE Output:** Receiver continuous audio line output. Adjustable levels are provided by the internal control RV3) An RCA connector (unbalanced) is provided. A Balanced output is available at the DIN connector on the rear panel (option).

**SPKR Output:** Audio output capable of driving an 8 Ohm speaker, 0.3 watt. RCA connector.

**VOL:** A screwdriver volume control for the SPKR powered audio output.

**POWER:** In the individual units (AF315 ), this is a center positive connector for 12 VDC, 300mA, input power. The input power is normally derived from a wall converter (115 VAC to 12 VDC) which is supplied, but other +12VDC sources can be used. In the AFC3 chassis mounted unit, the power is derived from the AFC3 chassis.

FIGURE 2.0

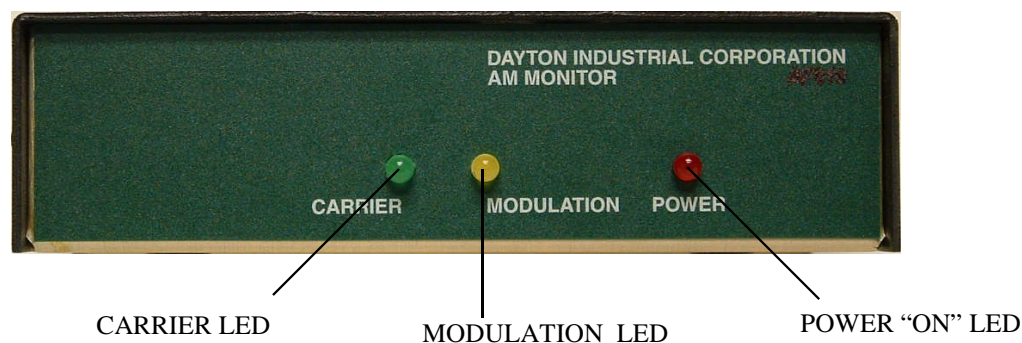

AF315 FRONT PANEL (Individual unit or Front Panel Controls of the AFC3)

### FRONT PANEL INDICATORS:

**POWER:** Indicator; Red LED that lights as long as power is applied. In the AFC3 chassis power is derived from the AFC3.

**CARRIER:** Indicator; Green LED that lights when the main carrier is present and above a preset received level (internal adjustment RV2).

**MODULATION:** Indicator; When a "CARRIER indicator is lighted, this Amber LED will increase and decrease in intensity with the modulation audio. If there is no carrier (CARRIER light "off"), the MODULATION indicator may be "on" continuously with noise. If there is an un-modulated carrier present, then the CARRIER light will be "on" and the MODULATION light will be "off".

### OPERATION:

Operation is straight forward. Connections are made to the appropriate connectors and power is applied. The POWER indicator should be bright. The LINE and SPKR outputs will be active. The SPKR output volume is controlled by the rear panel VOL screwdriver adjust control. If a carrier is present, the CARRIER light will be bright and the MODULATION indicator intensity will fluctuate with the audio that is present.

### TROUBLESHOOTING:

No attempt to service or adjust the receiver should be made.

If power is applied, but the receiver does not operate, and it is a new unit, then please return it to the factory for an exchange. If it should fail after some time in service, check the 115 VAC source to make sure power has not been dis-connected. If the 115 VAC is verified, try replacing the 115VAC to 12 VDC power converter. If the receiver still fails to operate, the failure must be internal to the receiver and the receiver should be returned to the factory for service.

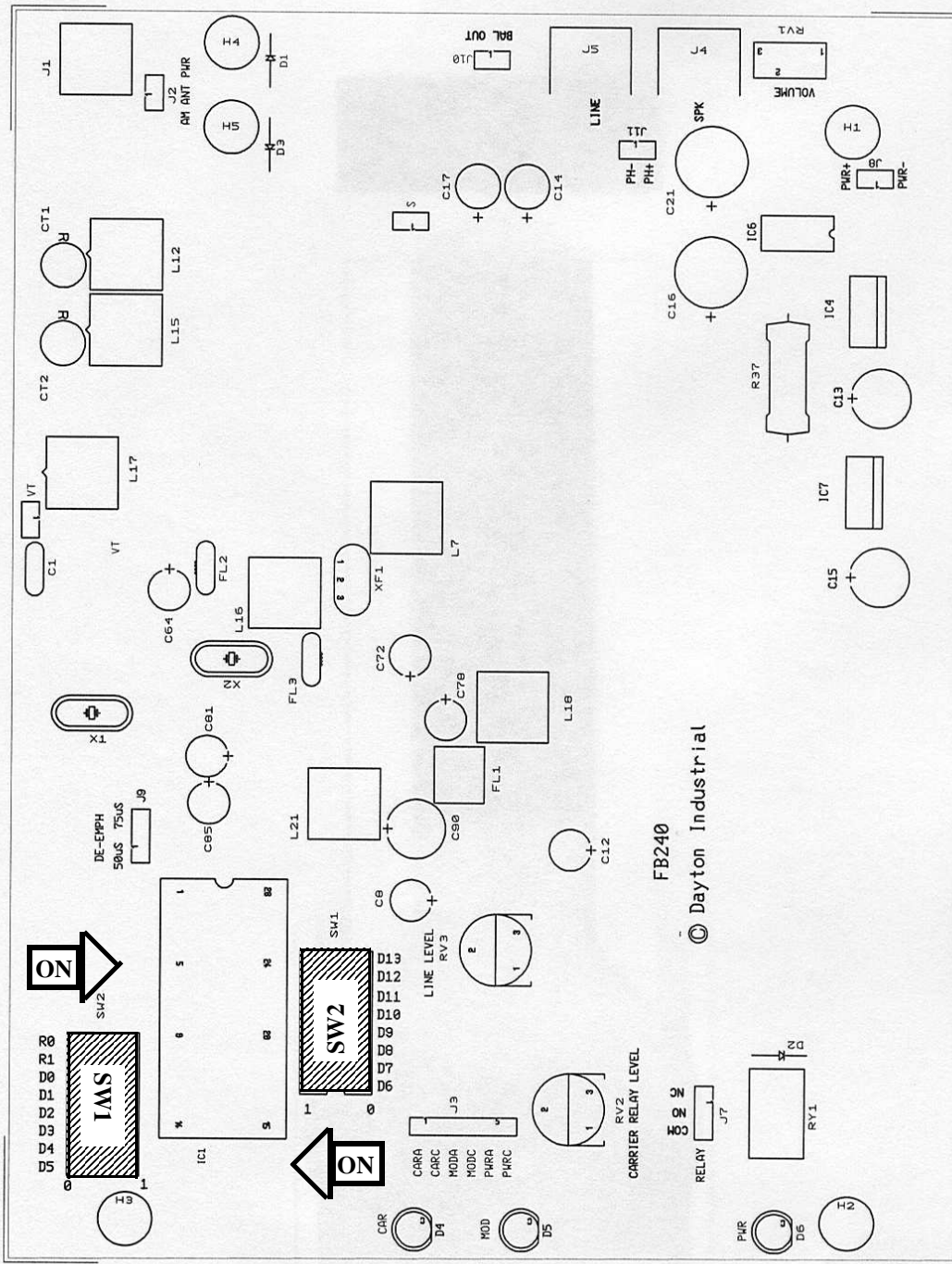

Model AF315 AM Receiver Printed Circuit Board Parts layout showing position of the DIP switch (SW1 and SW2)

**DAYTON INDUSTRIAL CORPORATION**  
 2237 Industrial Blvd Sarasota, Florida 34234  
 Telephone: (941) 351-4454 Fax: (941) 351-6081  
 Visit our website at [www.daytonindustrial.com](http://www.daytonindustrial.com)

AM tuner settings for 10kHz channels (NOTE: R0=0 R1=0)

FREQUENCY	D0	D1	D2	D3	D4	D5	D6	D7	D8	D9	D10	D11	D12	D13		
530	1	1	0	0	1	1	0	0	0	1	0	0	1	0	0	0
540	0	0	1	0	0	1	1	0	0	0	1	0	0	1	0	0
550	1	0	1	0	0	1	1	0	0	0	1	0	0	1	0	0
560	0	1	1	0	0	1	1	0	0	1	0	0	1	0	0	0
570	1	1	0	0	1	1	0	0	1	0	0	1	0	0	0	0
580	0	0	1	0	0	1	1	0	0	0	1	0	0	1	0	0
590	1	0	0	1	0	1	1	0	0	0	1	0	0	1	0	0
600	0	1	0	1	0	1	1	0	0	0	1	0	0	1	0	0
610	1	1	0	1	0	1	1	0	0	0	1	0	0	1	0	0
620	0	0	1	1	0	1	1	0	0	0	1	0	0	1	0	0
630	1	0	1	1	0	1	1	0	0	0	1	0	0	1	0	0
640	0	1	1	0	1	1	0	0	0	0	1	0	0	1	0	0
650	1	1	1	0	1	1	0	0	0	1	0	0	1	0	0	0
660	0	0	0	1	1	1	1	0	0	0	1	0	0	1	0	0
670	1	0	0	0	1	1	1	0	0	0	1	0	0	1	0	0
680	0	1	0	0	1	1	1	0	0	0	1	0	0	1	0	0
690	1	1	0	0	1	1	1	0	0	0	1	0	0	1	0	0
700	0	0	1	0	1	1	1	0	0	0	1	0	0	1	0	0
710	1	0	1	0	1	1	1	0	0	0	1	0	0	1	0	0
720	0	1	1	0	1	1	1	0	0	0	1	0	0	1	0	0
730	1	1	0	1	1	1	1	0	0	0	1	0	0	1	0	0
740	0	0	1	1	1	1	1	0	0	0	1	0	0	1	0	0
750	1	0	0	1	1	1	1	0	0	0	1	0	0	1	0	0
760	0	1	0	1	1	1	1	0	0	0	1	0	0	1	0	0
770	1	1	0	1	1	1	1	0	0	0	1	0	0	1	0	0
780	0	0	1	1	1	1	1	0	0	0	1	0	0	1	0	0
790	1	0	1	1	1	1	1	0	0	0	1	0	0	1	0	0
800	0	1	1	1	1	1	1	0	0	0	1	0	0	1	0	0
810	1	1	1	1	1	1	1	0	0	0	1	0	0	1	0	0
820	0	0	0	0	0	0	0	1	0	0	1	0	0	1	0	0
830	1	0	0	0	0	0	0	1	0	0	1	0	0	1	0	0
840	0	1	0	0	0	0	0	1	0	0	1	0	0	1	0	0
850	1	1	0	0	0	0	0	1	0	0	1	0	0	1	0	0
860	0	0	1	0	0	0	0	1	0	0	1	0	0	1	0	0
870	1	0	1	0	0	0	0	1	0	0	1	0	0	1	0	0
880	0	1	1	0	0	0	0	1	0	0	1	0	0	1	0	0
890	1	1	1	0	0	0	0	1	0	0	1	0	0	1	0	0
900	0	0	0	1	0	0	0	1	0	0	1	0	0	1	0	0
910	1	0	0	1	0	0	0	1	0	0	1	0	0	1	0	0

10kHz channels

FREQUENCY	D0	D1	D2	D3	D4	D5	D6	D7	D8	D9	D10	D11	D12	D13	
920	0	1	0	1	0	0	0	1	0	0	1	0	0	0	0
930	1	1	0	1	0	0	0	1	0	0	1	0	0	0	0
940	0	0	1	1	0	0	0	1	0	0	1	0	0	0	0
950	1	0	1	1	0	0	0	1	0	0	1	0	0	0	0
960	0	1	1	1	0	0	0	1	0	0	1	0	0	0	0
970	1	1	1	1	0	0	0	1	0	0	1	0	0	0	0
980	0	0	0	1	0	0	0	1	0	0	1	0	0	0	0
990	1	0	0	0	1	0	0	1	0	0	1	0	0	0	0
1000	0	1	0	0	1	0	0	1	0	0	1	0	0	0	0
1010	1	1	0	0	1	0	0	1	0	0	1	0	0	0	0
1020	0	0	1	0	1	0	0	1	0	0	1	0	0	0	0
1030	1	0	1	0	1	0	0	1	0	0	1	0	0	0	0
1040	0	1	1	0	1	0	0	1	0	0	1	0	0	0	0
1050	1	1	1	0	1	0	0	1	0	0	1	0	0	0	0
1060	0	0	0	1	1	0	0	1	0	0	1	0	0	0	0
1070	1	0	0	1	1	0	0	1	0	0	1	0	0	0	0
1080	0	1	0	1	1	0	0	1	0	0	1	0	0	0	0
1090	1	1	0	1	1	0	0	1	0	0	1	0	0	0	0
1100	0	0	1	1	1	0	0	1	0	0	1	0	0	0	0
1110	1	0	1	1	1	0	0	1	0	0	1	0	0	0	0
1120	0	1	1	1	1	0	0	1	0	0	1	0	0	0	0
1130	1	1	1	1	1	0	0	1	0	0	1	0	0	0	0
1140	0	0	0	0	1	0	0	1	0	0	1	0	0	0	0
1150	1	0	0	0	1	0	0	1	0	0	1	0	0	0	0
1160	0	1	0	0	1	0	0	1	0	0	1	0	0	0	0
1170	1	1	0	0	0	1	0	1	0	0	1	0	0	0	0
1180	0	0	1	0	0	1	0	1	0	0	1	0	0	0	0
1190	1	0	1	0	0	1	0	1	0	0	1	0	0	0	0
1200	0	1	1	0	0	1	0	1	0	0	1	0	0	0	0
1210	1	1	1	0	0	1	0	1	0	0	1	0	0	0	0
1220	0	0	1	0	0	1	0	1	0	0	1	0	0	0	0
1230	1	0	0	1	0	1	0	1	0	0	1	0	0	0	0
1240	0	1	0	1	0	1	0	1	0	0	1	0	0	0	0
1250	1	1	0	1	0	1	0	1	0	0	1	0	0	0	0
1260	0	0	1	1	0	1	0	1	0	0	1	0	0	0	0
1270	1	0	1	1	0	1	0	1	0	0	1	0	0	0	0
1280	0	1	1	1	0	1	0	1	0	0	1	0	0	0	0
1290	1	1	1	1	0	1	0	1	0	0	1	0	0	0	0
1300	0	0	0	0	1	1	0	1	0	0	1	0	0	0	0
1310	1	0	0	0	1	1	0	1	0	0	1	0	0	0	0
1320	0	1	0	0	1	1	0	1	0	0	1	0	0	0	0

10kHz channels

FREQUENCY	D0	D1	D2	D3	D4	D5	D6	D7	D8	D9	D10	D11	D12	D13	
1330	1	1	0	0	1	1	0	1	0	0	1	0	0	0	0
1340	0	0	1	0	1	1	0	1	0	0	1	0	0	0	0
1350	1	0	1	0	1	1	0	1	0	0	1	0	0	0	0
1360	0	1	1	0	1	1	0	1	0	0	1	0	0	0	0
1370	1	1	1	0	1	1	0	1	0	0	1	0	0	0	0
1380	0	0	0	1	1	0	1	0	1	0	0	1	0	0	0
1390	1	0	0	1	1	0	1	0	1	0	0	1	0	0	0
1400	0	1	0	1	1	0	1	0	1	0	0	1	0	0	0
1410	1	1	0	1	1	0	1	0	1	0	0	1	0	0	0
1420	0	0	1	1	1	0	1	0	1	0	0	1	0	0	0
1430	1	0	1	1	1	0	1	0	1	0	0	1	0	0	0
1440	0	1	1	1	1	0	1	0	1	0	0	1	0	0	0
1450	1	1	1	1	1	0	1	0	1	0	0	1	0	0	0
1460	0	0	0	0	0	1	1	0	0	0	1	0	0	0	0
1470	1	0	0	0	0	1	1	0	0	0	1	0	0	0	0
1480	0	1	0	0	0	1	1	0	0	0	1	0	0	0	0
1490	1	1	0	0	0	1	1	0	0	0	1	0	0	0	0
1500	0	1	0	0	0	1	1	0	0	0	1	0	0	0	0
1510	1	0	1	0	0	0	1	1	0	0	1	0	0	0	0
1520	0	1	1	0	0	0	1	1	0	0	1	0	0	0	0
1530	1	1	1	0	0	0	1	1	0	0	1	0	0	0	0
1540	0	0	0	1	0	0	1	0	0	0	1	0	0	0	0
1550	1	0	0	0	1	0	0	1	0	0	1	0	0	0	0
1560	0	1	0	1	0	0	1	0	0	0	1	0	0	0	0
1570	1	1	0	1	0	0	1	0	0	0	1	0	0	0	0
1580	0	0	1	1	0	0	1	0	0	0	1	0	0	0	0
1590	1	0	1	1	0	0	1	0	0	0	1	0	0	0	0
1600	0	1	1	1	0	0	1	0	0	0	1	0	0	0	0
1610	1	1	1	1	0	0	1	0	0	0	1	0	0	0	0
1620	0	0	0	1	0	0	1	0	0	0	1	0	0	0	0
1630	1	0	0												

