

# MODEL AF610 NOAA WEATHER RADIO OPERATION MANUAL

## GENERAL:

A special receiver for the NOAA weather radio broadcasts in the VHF public service bands at 162.400, 162.425, 162.450, 162.475, 162.500, 162.525 and 162.550 MHz. This receiver is designed to meet professional EAS equipment input requirements.

The receiver is PLL (phase lock loop) controlled. The frequency of operation is selected using an internal 3 position DIP switch. A continuous receiver LINE audio output is provided. A second output (SPKR) is also provided. The SPKR output audio is controlled automatically by a tone detector circuit that monitors the receiver audio for the presence of a 1050 Hz and/or 1650 Hz tone signal. There is also a TEST / RESET toggle switch for activating the SPKR audio and ALARM light manually.

The receiver circuit board has 10 VDC automotive style regulators. Input power is derived from wall mounted power converters (115 VAC to 12 DC) or other 12 VDC sources. The receiver is housed in a metal case or configured as one receiver in the AFC3 multiple receiver rack mount chassis.

## SPECIFICATIONS:

With modulation of 1 KHz at 3 KHz deviation:

### SENSITIVITY

|            |        |
|------------|--------|
| 12dB SINAD | 0.25uV |
| 20 dB S/N  | 0.50uV |
| 30 dB S/N  | 1.20uV |

|                               |        |
|-------------------------------|--------|
| Adjacent Channel Selectivity: | 65 dB  |
| Intermodulation Rejection:    | 55 dB  |
| Image Rejection:              | 50 dB  |
| Spurious Response Rejection:  | >60 dB |

|                                 |          |
|---------------------------------|----------|
| LINE Output                     | 1.0V RMS |
| (open circuit R out is 600Ohms) |          |

|                              |           |
|------------------------------|-----------|
| SPKR Output                  | 0.3 Watts |
| (Adjustable, Volume Control) |           |

|                              |           |
|------------------------------|-----------|
| Alarm Response Time:         | 3 Seconds |
| (10 second tone transmitted) |           |

|                           |          |
|---------------------------|----------|
| Tone Detection Bandwidth: | +/- 5 Hz |
|---------------------------|----------|

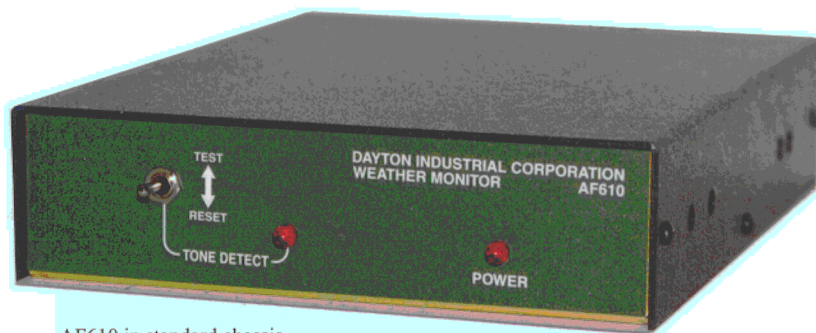

AF610 in standard chassis

|                               |              |
|-------------------------------|--------------|
| Power:                        | 12VDC, 300mA |
| (300mA converter is provided) |              |

|                  |                         |
|------------------|-------------------------|
| Metal Case Size: | 6.0" W x 8" D x .3/4" H |
| Weight:          | 1.5 lbs                 |

### OPTIONS AVAILABLE:

- Option -MF 19" front panel rack mount (1 3/4")
  - Option -B Balanced LINE output via DIN connector
  - Option -R Relay output for alarm circuit via DIN
  - Option -TD Second tone (1650Hz) alarm detector
- Option TD is now a standard feature!*

AF610 can be selected as one of the receivers in the AFC3 package (options B & R are standard in the AFC3).

**DAYTON INDUSTRIAL CORPORATION**  
2237 Industrial Blvd  
Sarasota, Florida 34234  
Telephone: (941) 351-4454 Fax: (941) 351-6081  
Visit our website at [www.daytonindustrial.com](http://www.daytonindustrial.com)

**SETTING THE FREQUENCY OF OPERATION:**

The 3 POSITION DIP SWITCH used to set the frequency of operation is located inside the receiver case. To access the switch, remove the receiver cover by removing the six (6) screws located on the sides of the receiver case. Once the cover has been removed, locate SW1, the three position DIP switch, (see attached diagram). The switch is marked with 1,2,3 indicating the switch, and the circuit board is marked with the "on" direction. The switch is a "rocker" switch adjusted using a pencil, small screwdriver, etc. The frequency of operation is selected by the following switch positions:

| FREQUENCY | 162.550 | 162.525 | 162.500 | 162.475 | 162.450 | 162.425 | 162.400 |
|-----------|---------|---------|---------|---------|---------|---------|---------|
| Switch 1  | ON      | ON      | OFF     | ON      | ON      | OFF     | OFF     |
| Switch 2  | OFF     | ON      | ON      | ON      | OFF     | OFF     | ON      |
| Switch 3  | OFF     | ON      | ON      | OFF     | ON      | ON      | OFF     |

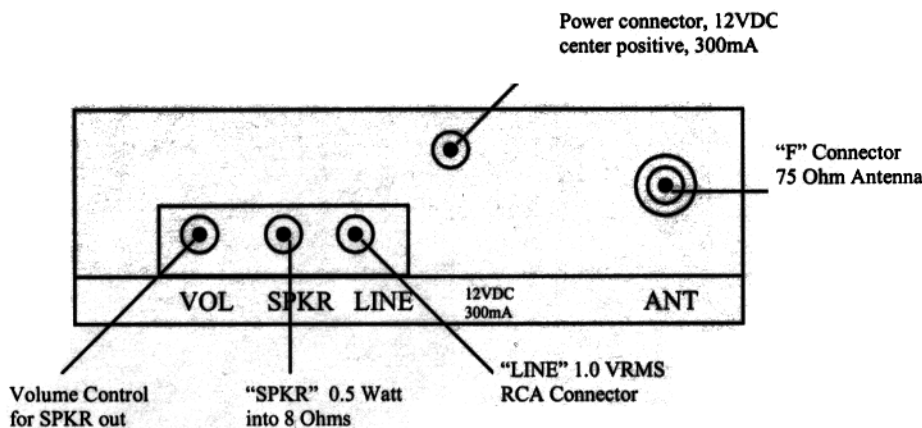

**AF 610 REAR PANEL** (Individual Unit Chassis or as mounted in the AFC3 chassis)

**REAR PANEL CONNECTORS: (Standard)**

**ANT:** Antenna Input for the receiver. This is an "F" connector. The input should be 75 Ohm coaxial cable to the antenna.

**LINE Out:** This is a continuous audio output, RCA connector, 1 volt RMS (unbalanced). This "LINE" audio output is unaffected by the status of the "ALARM" circuits.

**SPKR Audio Output:** This output is controlled by the ALARM circuitry. If the "ALARM" is ON, this audio output is active. This audio amplifier output is capable of driving a 4 or 8 Ohm speaker with 0.3 watts.

**VOL:** This is a screwdriver adjust potentiometer that sets the volume of the "SPKR" audio output.

**POWER:** In the individual units (AF610), this is a center positive connector for 12 VDC, 300 mA, input power. The input power is normally derived from a wall converter (115VAC to 12 VDC) (supplied). In the AFC3 multiple receiver chassis unit, the power is derived from the AFC3 chassis.

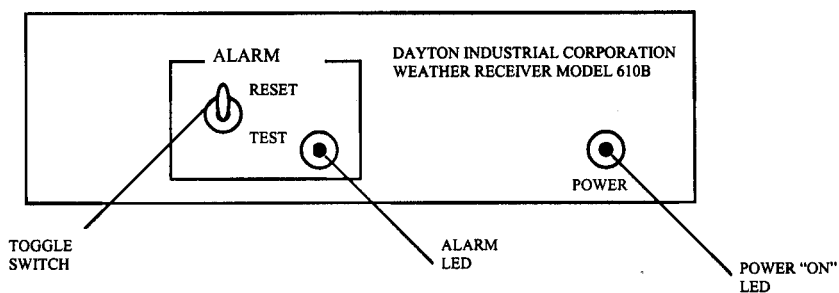

**AF610 FRONT PANEL** (Individual Unit or Front Panel Controls of the AFC3)

### **FRONT PANEL INDICATORS/CONTROLS:**

**POWER:** Indicator; Green LED that lights as long as the power is applied. In the AFC3 chassis, power is derived from the AFC3.

**ALARM:** Indicator; Red LED that lights when an ALARM signal is received. The Alarm signal is activated when the receiver circuitry recognizes the presence of a 1050Hz (and/or 1650Hz, (option) ) audio tone being present for a preset period of time, normally 3 seconds.

**TEST:** Switch; One position of the front panel mounted toggle switch. This switch will "un mute" the receiver SPKR audio, in the same manner as the reception of an alarm signal. Activate this switch to operate the receiver's SPKR audio. This switch has no effect on the receiver's LINE output which is a continuous audio output used for feeding the EAS or other monitoring equipment.

**RESET:** Switch; One position of the front panel mounted toggle switch. This switch will reset the receiver SPKR audio output and mute the SPKR audio until the next alarm is detected. This switch has no effect on the receiver's LINE audio output.

### **OPERATION:**

Operation is straight forward. Connections are made to the appropriate connectors and then power is applied. The front panel mounted LED marked POWER should be bright. The LINE audio output will be active. The SPKR audio output can be activated by pressing the TEST switch, and then reset to mute by pushing the RESET switch. SPKR output volume is controlled by the VOL screwdriver adjust control.

### **TROUBLESHOOTING:**

No attempt to service or adjust this receiver should be made.

If power is applied, but the receiver doesn't operate, and it is a new unit, then please return it to the factory for an exchange. If it should fail after some time in service, check the 115 VAC source to make sure power has not been dis-connected. If the 115 VAC is verified, try replacing the 115 to 12VDC power converter. If the receiver still fails to operate, the failure must be internal to the receiver and the receiver should be returned to the factory for service.

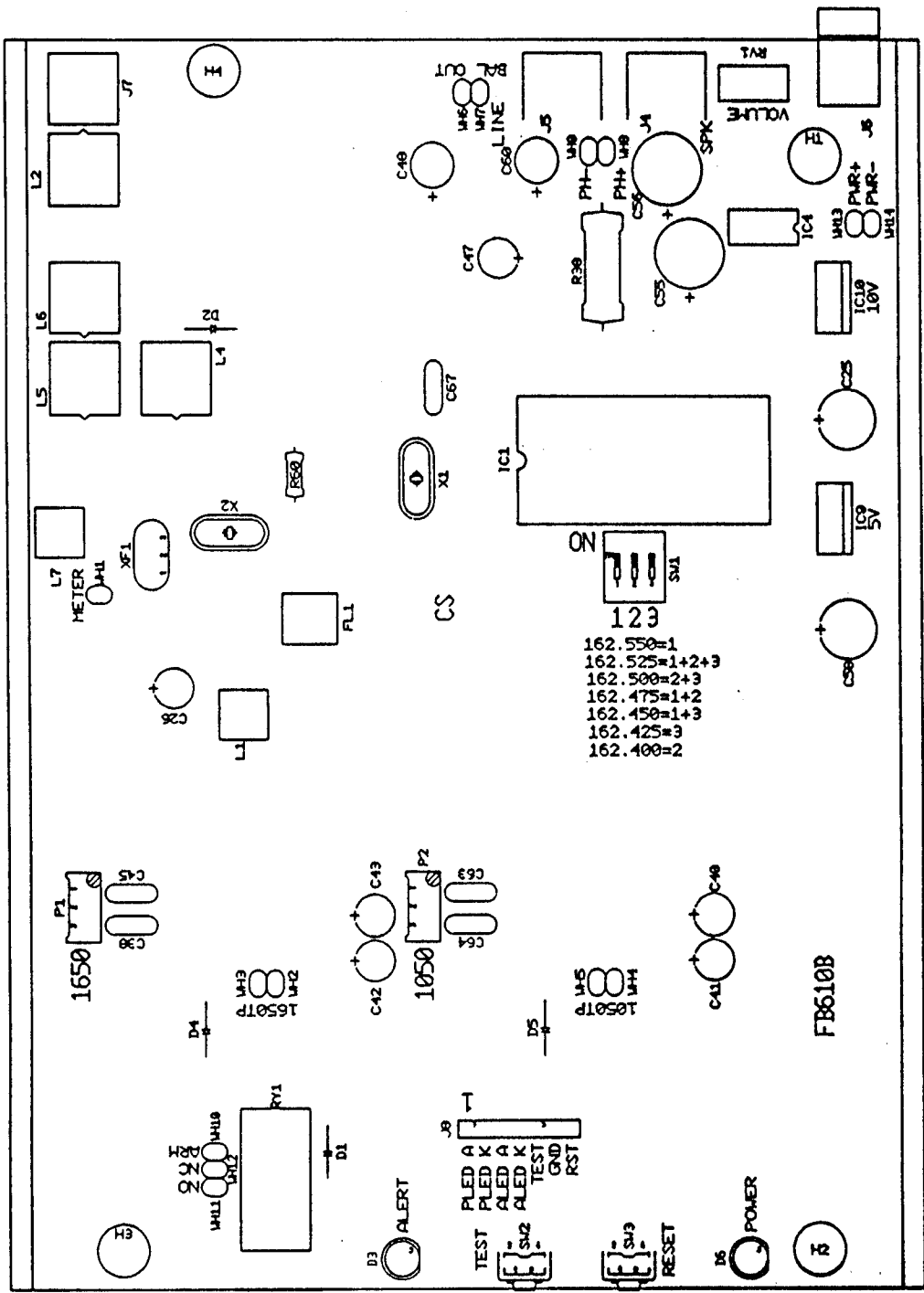

Model AF610 Weather Receiver Printed Circuit Board Parts layout showing position of the DIP switch used to set the operation frequency

**DAYTON INDUSTRIAL CORPORATION**  
 2237 Industrial Blvd, Sarasota, Florida 34234  
 Telephone: (941) 351-4454 Fax: (941) 351-6081  
 Visit our website at [www.daytonindustrial.com](http://www.daytonindustrial.com)