

MODEL AF852 HF PUBLIC SERVICE MONITOR with CTCSS OPERATION MANUAL (V1)

GENERAL:

A special monitor receiver for the Public Service Band (30 to 50MHz). This receiver is designed to meet professional monitoring and EAS equipment input requirements. The receiver is PLL (phase lock loop) controlled. The frequency of operation is selected using internal BCD switches. A receiver LINE audio output (adjustable) is provided. A speaker output (SPKR) is also provided. The SPKR output is adjustable by rear panel volume control (VOL). The audio outputs will be available continuously or controlled by the CTCSS (Continuous Tone Controlled Sub-audible Squelch) tone decoder. The tone decoder output indicates the desired sub-audible tone (as set by internal switches) has been received. An internal relay is also provided that is controlled by the CTCSS tone decoder. Front panel indicators (LED's) are provided for Power, Carrier, Modulation, and Tone Detector Operation.

The receiver circuit board has 10 VDC automotive style regulators. Input power is derived from wall mounted power converters (115 VAC to 12 DC) or other 12 VDC sources, vehicular or battery. The receiver is housed in a metal case or configured as one receiver in the AFC3 multiple receiver rack mount chassis.

SPECIFICATIONS:

Frequency of Operation: 30 to 50MHz
RF Input Impedance: 75 Ohm
Frequency Increments: 5 KHz

With modulation of 1 KHz at 5 KHz deviation:

Sensitivity:

12dB SINAD 0.25uV
20 dB S/N 0.50uV
30 dB S/N 1.20uV

Adjacent Channel Selectivity: 60 dB
Intermodulation Rejection: 65 dB
Image Rejection: 50 dB
Spurious Response Rejection: >60 dB
LINE Output: 1.0V RMS (adj)
(open circuit R out is 600Ohms)
SPKR Output: 0.5 Watts, 8 Ohm
(Adjustable, Volume Control)
CTCSS: Standard 39 Tone Decoder
1% Bandwidth
Power: 12VDC, 300 mA
(300 mA converter (provided))
Metal Case Size: 6.0" W x 8" D x 1-3/4" H
Weight: 1.5 lbs

CONTROLS AND INDICATORS:

Front Panel Controls:

TONE TEST/RESET Switch: Selects continuous monitoring or CTCSS tone controlled squelch.

Front Panel Indicators:

POWER: Red LED indicates power applied.
CARRIER: Green LED indicates received carrier

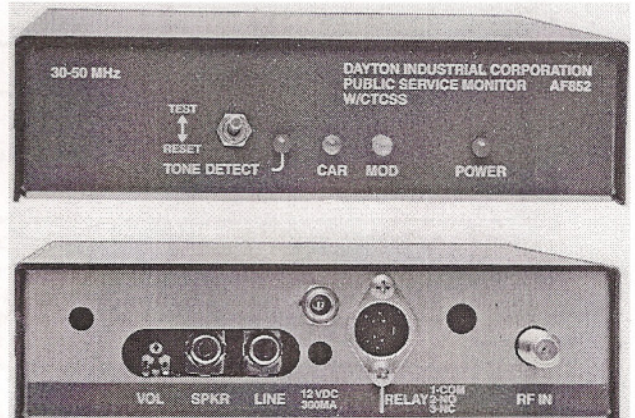

exceeds the set SQUELCH setting and the correct TONE has been detected.

MODULATION: Yellow LED intensity varies with carrier modulation level.

TONE DETECT: Red LED indicates desired sub-audible tone has been received

Rear Panel Connectors/Controls:

RF IN: "F" connector
POWER: 2mm, center positive
LINE: RCA
SPKR: RCA
VOL: Potentiometer
BAL OUT/RELAY (optional): DIN

Internal Controls:

SQL: (RV2) Squelch setting potentiometer
LINE LEVEL: (RV3) Line level adjustment
RELAY: Relay output controlled by CTCSS Tone Decoder circuit

OPTIONS:

Option -MF Individual 19 inch rack mount (1 3/4"),
Option -B Balanced Line audio output,
Option -C3 One receiver of the AFC3 multiple receiver chassis,

DAYTON INDUSTRIAL CORPORATION

2237 Industrial Blvd., Sarasota, Florida 34234 TEL:(941) 351 4454 FAX: (941) 351 6081

daytonindustrial.com

Model AF852 PUBLIC SERVICE MONITOR Operation Manual

SETTING THE FREQUENCY OF OPERATION:

There are three (3) BCD switches and one three position DIP switch used in setting the frequency of operation for this receiver. Access to the printed circuit board requires that the receiver top chassis panel be removed. A circuit board component placement diagram is attached to this manual.

Switch SW1 (the DIP) switch has three switch positions. The SW1 positions (1) and (2) select the frequency range 30 or 40 (MHz) depending on switch positions. SW1 position (3) sets the last frequency digit as a 5 (KHz) (On) or as a zero (Off).

FREQUENCY	3x.xx5	4x.xx0
Switch 1	OFF	ON
Switch 2	OFF	OFF
Switch 3 (5 or 0 KHz)	ON	OFF

The BCD switches, SW4, SW2, and SW3 set the 1.000 MHz, the 0.100 MHz, and the 0.010 MHz portions of the operating frequency. For example:

Operating Frequency desired: —>>>	35.670MHz	49.875MHz	38.035MHz	41.650MHz
SW1 (1) (Sets Xx.xxx)	OFF (3x.xxx)	ON (4x.xxx)	OFF (3x.xxx)	ON (4x.xxx)
SW1 (2)	OFF	OFF	OFF	OFF
SW1 (3) (Sets xx.xx0)	OFF (3x.xx0)	ON (4x.xx5)	ON (3x.xx5)	OFF (4x.xx0)
SW4 (Sets xX.xx0)	5 (35.xx0)	9 (49.xx5)	8 (38.xx5)	1 (41.xx0)
SW2 (Sets xx.Xx0)	6 (35.6x0)	8 (49.8x5)	0 (38.0x5)	6 (41.6x0)
SW3 (Sets xx.xX0)	7 (35.670)	7 (49.875)	3 (38.035)	5 (41.650)

REAR PANEL CONNECTORS: (Standard)

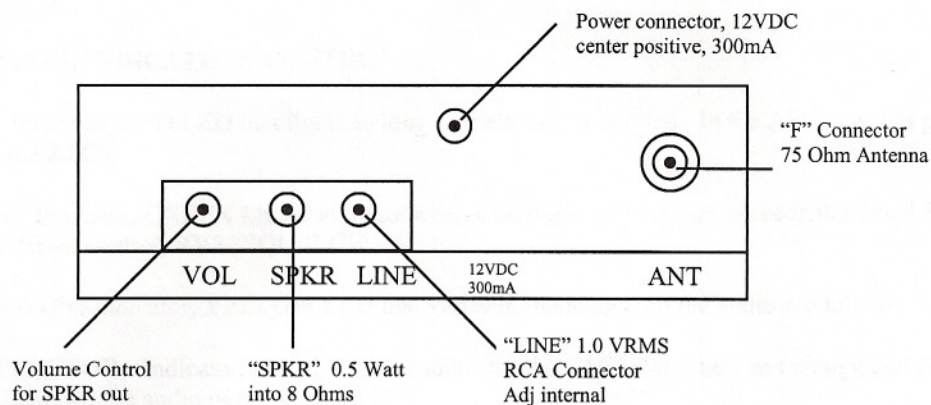

AF 852 REAR PANEL (Individual Unit Chassis or as mounted in the AFC3 chassis)

Model AF852 PUBLIC SERVICE MONITOR Operation Manual

ANT: Antenna Input for the receiver. This is an "F" connector. The input should be 75 Ohm coaxial cable to the antenna.

LINE Out: Audio output, RCA connector, 1 volt RMS nominal into 600 Ohms. (adjustable by internal control, RV3)

SPKR Audio Output: This audio amplifier output is capable of driving a 4 or 8 Ohm speaker with 0.5 watts. (Adjustable by rear panel VOL control)

VOL: This is a screwdriver adjust potentiometer that sets the volume of the "SPKR" audio output.

POWER: In the individual units (AF852), this is a center positive connector for 12 VDC, 300 mA, input power. The input power is normally derived from a wall converter (115VAC to 12 VDC) (supplied). In the AFC3 chassis mounted unit, the power is derived from the AFC3 chassis.

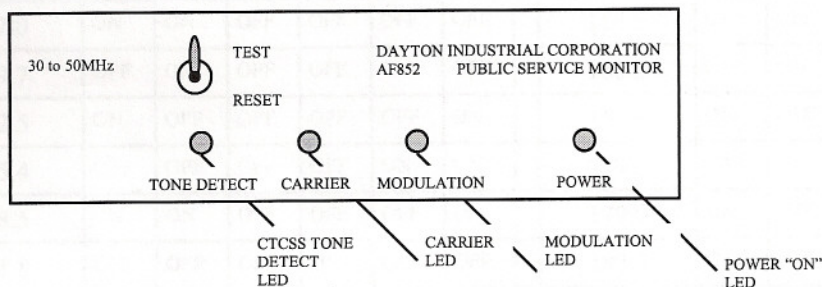

AF852 FRONT PANEL (Individual Unit or Front Panel Controls of the AFC3)

FRONT PANEL INDICATORS/CONTROLS:

POWER: Indicator; RED LED that lights as long as the power is applied. In the AFC3 chassis power is derived from the AFC3.

CARRIER: Indicator, GREEN LED that lights when a carrier is present that exceeds the Squelch control level set by the internal control, RV2 "SQUELCH".

MODULATION: Indicator, YELLOW LED that varies in intensity with the audio modulation.

TONE DETECTOR: Indicator, RED LED, that indicates the CTCSS circuitry has recognized the tone set by SW5, and activated the audio outputs.

TONE DETECT/LISTEN SWITCH: A two position switch. When in the "RESET" position, the CTCSS circuit is in operation and audio will be present only if the proper tone is detected. When in the "TEST" position, the receiver audio will be present as long as the incoming signal exceeds the SQL threshold. The tone does not have to be present.

Model AF852 PUBLIC SERVICE MONITOR Operation Manual

SUB-AUDIBLE TONE DECODER:

The tone decoder can be set to detect any of the 39 standard CTCSS tones. These tones are sent along with the transmitted audio. The tones are below the normal frequency response of the receiver, and not heard in the audio. If the receiver is set to detect the tone being transmitted, the receiver will automatically un-mute the receiver audio section. This technique is particularly valuable in the HF communication band to eliminate interfering signals on the same operating frequency. A continuous "ON" monitoring position is also provided. For the tone detector circuit to be in operation, the front panel "TEST/RESET" switch must be in the "RESET" position. To set the tone frequency to be detected, the DIP switch SW5, located on the circuit board, is set according to the settings shown in the table provided below:

TONE FREQ (Hz)	1	2	3	4	5	6	TONE FREQ (Hz)	1	2	3	4	5	6
67.0	OFF	OFF	OFF	OFF	OFF	OFF	141.3	ON	ON	OFF	ON	ON	ON
69.3	SW5 SWITCH SETTINGS					OFF	146.2	ON	SW5 SWITCH SETTINGS				
71.9	ON	OFF	OFF	OFF	OFF	OFF	151.4	ON	ON	ON	OFF	OFF	OFF
74.4	OFF	OFF	OFF	OFF	OFF	ON	156.7	ON	OFF	ON	OFF	OFF	ON
77.0	ON	ON	OFF	OFF	OFF	OFF	159.8	OFF	OFF	ON	ON	ON	OFF
79.7	OFF	OFF	OFF	OFF	ON	OFF	162.2	ON	ON	ON	OFF	OFF	ON
82.5	ON	OFF	OFF	OFF	OFF	ON	167.9	ON	OFF	ON	OFF	ON	OFF
85.4	OFF	OFF	OFF	OFF	ON	ON	173.8	ON	ON	ON	OFF	ON	OFF
88.5	ON	ON	OFF	OFF	OFF	ON	179.9	ON	OFF	ON	OFF	ON	ON
91.5	OFF	OFF	OFF	ON	OFF	OFF	183.5	OFF	OFF	ON	ON	OFF	ON
94.8	ON	OFF	OFF	OFF	ON	OFF	186.2	ON	ON	ON	OFF	ON	ON
97.4	OFF	OFF	OFF	ON	OFF	ON	189.9	OFF	OFF	ON	ON	OFF	OFF
100	ON	ON	OFF	OFF	ON	OFF	192.8	ON	OFF	ON	ON	OFF	OFF
103.5	ON	OFF	OFF	OFF	ON	ON	196.6	OFF	OFF	ON	OFF	ON	ON
107.2	ON	ON	OFF	OFF	ON	ON	203.5	ON	ON	ON	ON	OFF	OFF
110.9	ON	OFF	OFF	ON	OFF	OFF	210.7	ON	OFF	ON	ON	OFF	ON
114.8	ON	ON	OFF	ON	OFF	OFF	218.1	ON	ON	ON	ON	OFF	ON
118.8	ON	OFF	OFF	ON	OFF	ON	225.7	ON	OFF	ON	ON	ON	OFF
123.0	ON	ON	OFF	ON	OFF	ON	233.6	ON	ON	ON	ON	ON	OFF
127.3	ON	OFF	OFF	ON	ON	OFF	241.8	ON	OFF	ON	ON	ON	ON
131.8	ON	ON	OFF	ON	ON	OFF	250.3	ON	ON	ON	ON	ON	ON
136.5	ON	OFF	OFF	ON	ON	ON	Monitor	OFF	OFF	ON	ON	ON	ON

DAYTON INDUSTRIAL CORPORATION

Tel: 941 351 4454 Fax: 941 351 6081 E-Mail: daytonindustrial@aol.com

OPERATION:

Operation is straight forward. The top cover is removed, frequency setting switches set to the correct positions for the desired operating and tone detect frequency and the top cover replaced. Connections are made to the appropriate connectors and then power is applied. The front panel mounted LED marked POWER should be bright. The LINE audio output and SPKR audio output will be active with the front panel switch in the "TEST" position. The front panel CARRIER LED will light if the received signal exceeds the SQUELCH level, and the proper tone is received. The MODULATION LED will vary in intensity with the audio modulation present. A continuous MODULATION indication may indicate only noise is present.

Placing the front panel switch in the "RESET" position will activate the "CTCSS" tone decoder circuit and the LINE and SPKR audio will be present only if the received signal is above the receiver squelch setting and contains the tone which matches the receiver tone decoder settings, (SW5).

TROUBLESHOOTING:

If power is applied, but the receiver does not operate, and it is a new unit, then please return it to the factory for an exchange. If it should fail after some time in service, check the 115 VAC source to make sure power has not been dis-connected. If the 115 VAC is verified, try replacing the 115 to 12VDC power converter. If the receiver still fails to operate, the failure must be internal to the receiver and the receiver should be returned to the factory for service.

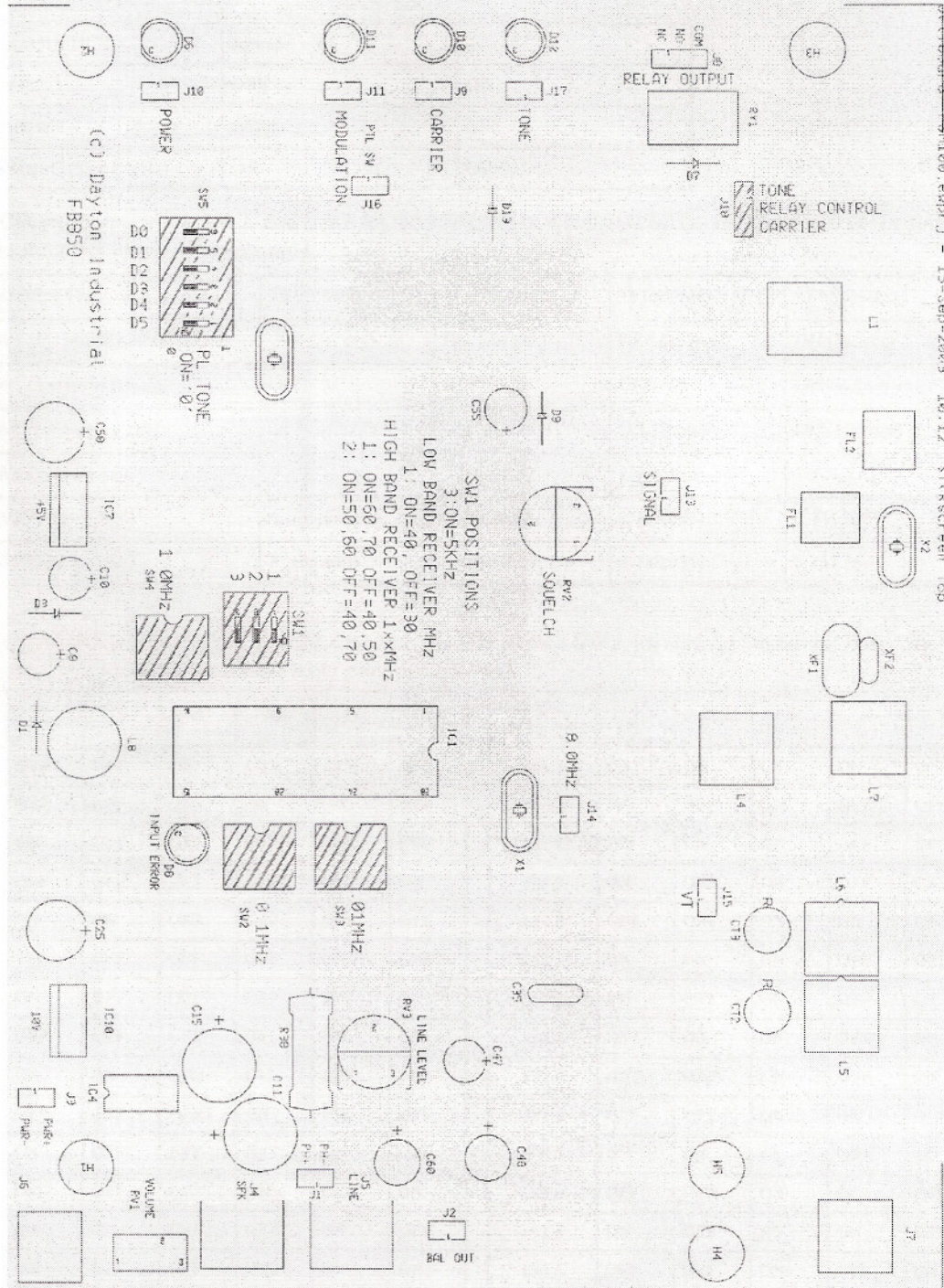

Model AF852 Public Service Monitor Printed Circuit Board Parts layout showing position of the DIP and BCD switches used to set the operation frequency and CTCSS tone decoder frequency

DAYTON INDUSTRIAL CORPORATION
 2237 Industrial Blvd, Sarasota, Florida 34234
 Tel:(941) 351 4454 Fax: (941) 351 6081
www.daytonindustrial.com

FREQUENCY OF OPERATION SETTINGS:

Switch SW1 (the DIP) switch has three switch positions. The SW1 positions (1) and (2) select the frequency range 30 or 40 (MHz) depending on switch positions. SW1 position (3) sets the last frequency digit as a 5 (KHz) (On) or as a zero (Off).

FREQUENCY	3x.xx5	4x.xx0
Switch 1	OFF	ON
Switch 2	OFF	OFF
Switch 3 (5 or 0 KHz)	ON	OFF

The BCD switches, SW4, SW2, and SW3 set the 1.000 MHz, the 0.100 MHz, and the 0.010 MHz portions of the operating frequency. For example:

Operating Frequency desired: >	35.670MHz	49.875MHz	38.035MHz	41.650MHz
SW1 (1) (Sets Xx.xxx)	OFF (3x.xxx)	ON (4x.xxx)	OFF (3x.xxx)	ON (4x.xxx)
SW1 (2)(No Function)	OFF	OFF	OFF	OFF
SW1 (3) (Sets xx.xx0)	OFF (3x.xx0)	ON (4x.xx5)	ON (3x.xx5)	OFF (4x.xx0)
SW4 (Sets xX.xx0)	5 (35.xx0)	9 (49.xx5)	8 (38.xx5)	1 (41.xx0)
SW2 (Sets xx.Xx0)	6 (35.6x0)	8 (49.8x5)	0 (38.0x5)	6 (41.6x0)
SW3 (Sets xx.xX0)	7 (35.670)	7 (49.875)	3 (38.035)	5 (41.650)

To set the **TONE FREQUENCY** to be detected, the DIP switch SW5, located on the circuit board, is set according to the settings shown in the table provided below:

TONE FREQ (Hz)	1	2	3	4	5	6	TONE FREQ (Hz)	1	2	3	4	5	6
67.0	OFF	OFF	OFF	OFF	OFF	OFF	141.3	ON	ON	OFF	ON	ON	ON
69.3	OFF	OFF	OFF	ON	ON	OFF	146.2	ON	OFF	ON	OFF	OFF	OFF
71.9	ON	OFF	OFF	OFF	OFF	OFF	151.4	ON	ON	ON	OFF	OFF	OFF
74.4	OFF	OFF	OFF	OFF	OFF	ON	156.7	ON	OFF	ON	OFF	OFF	ON
77.0	ON	ON	OFF	OFF	OFF	OFF	159.8	OFF	OFF	ON	ON	ON	OFF
79.7	OFF	OFF	OFF	OFF	ON	OFF	162.2	ON	ON	ON	OFF	OFF	ON
82.5	ON	OFF	OFF	OFF	OFF	ON	167.9	ON	OFF	ON	OFF	ON	OFF
85.4	OFF	OFF	OFF	OFF	ON	ON	173.8	ON	ON	ON	OFF	ON	OFF
88.5	ON	ON	OFF	OFF	OFF	ON	179.9	ON	OFF	ON	OFF	ON	ON
91.5	OFF	OFF	OFF	ON	OFF	OFF	183.5	OFF	OFF	ON	ON	OFF	ON
94.8	ON	OFF	OFF	OFF	ON	OFF	186.2	ON	ON	ON	OFF	ON	ON
97.4	OFF	OFF	OFF	ON	OFF	ON	189.9	OFF	OFF	ON	ON	OFF	OFF
100	ON	ON	OFF	OFF	ON	OFF	192.8	ON	OFF	ON	ON	OFF	OFF
103.5	ON	OFF	OFF	OFF	ON	ON	196.6	OFF	OFF	ON	OFF	ON	ON
107.2	ON	ON	OFF	OFF	ON	ON	203.5	ON	ON	ON	ON	OFF	OFF
110.9	ON	OFF	OFF	ON	OFF	OFF	210.7	ON	OFF	ON	ON	OFF	ON
114.8	ON	ON	OFF	ON	OFF	OFF	218.1	ON	ON	ON	ON	OFF	ON
118.8	ON	OFF	OFF	ON	OFF	ON	225.7	ON	OFF	ON	ON	ON	OFF
123.0	ON	ON	OFF	ON	OFF	ON	233.6	ON	ON	ON	ON	ON	OFF
127.3	ON	OFF	OFF	ON	ON	OFF	241.8	ON	OFF	ON	ON	ON	ON
131.8	ON	ON	OFF	ON	ON	OFF	250.3	ON	ON	ON	ON	ON	ON
136.5	ON	OFF	OFF	ON	ON	ON	Monitor	OFF	OFF	ON	ON	ON	ON