

Models, 4100, 4110 FM Volumax

OPERATING AND MAINTENANCE INSTRUCTIONS

PROFESSIONAL PRODUCTS

CBS LABORATORIES

A Division of Columbia Broadcasting System, Inc.

Stamford, Connecticut 06905

OCTOBER 1972

TABLE OF CONTENTS

<u>Section</u>	<u>Title</u>	<u>Page</u>
I	INTRODUCTION	1-1
1-1	General	1-1
1-2	Functional Description	1-2
1-3	Physical Description	1-2
1-4	Warranty	1-5
1-5	Service and Repair	1-5
1-6	Specifications	1-6
II	INSTALLATION	2-1
2-1	Unpacking	2-1
2-2	Mechanical Installation and Operation Considerations	2-1
2-3	Power Source	2-4
2-4	Electrical Connections	2-7
III	OPERATIONAL SET-UP	3-1
3-1	General	3-1
3-2	Set-Up of Stereophonic FM Volumax Unit	3-1
3-3	Set-Up of Monophonic FM Volumax Unit	3-4
3-4	Proof-of-Performance Measurements	3-4
IV	THEORY OF OPERATION	4-1
4-1	General	4-1
4-2	Input Section (Board A2 or A5)	4-3
4-3	AGC Amplifier (Board A3)	4-5
4-4	High Frequency Processor (Board A1 or A4)	4-6
4-5	Output Section (Board A2 or A5)	4-8
4-6	Power Supply (Board A3)	4-9
V	MAINTENANCE	5-1
5-1	General	5-1
5-2	Alignment Procedure	5-2
5-3	Troubleshooting Input Section (Board A2 or A5)	5-6
5-4	Troubleshooting High Frequency Control Section (Board A1 or A4)	5-6
5-5	Troubleshooting Output Section (Board A2 or A5)	5-7
5-6	Troubleshooting AGC Section (Board A3)	5-7
5-7	Troubleshooting Gain Meter Circuit	5-9

TABLE OF CONTENTS (cont)

<u>Section</u>	<u>Title</u>	<u>Page</u>
VI	PARTS LISTS	6-1
6-1	General	6-1
6-2	Resistors	6-1
6-3	Diodes and Transistors	6-1
6-4	Manufacturers' Name Abbreviations	6-2
6-5	Main Assembly (Model 4110 or 4100)	6-3
6-6	High Frequency Board A1 and A4	6-4
6-7	Input-Output Board A2 and A5	6-7
6-8	Power Supply and AGC Board A3	6-10
6-9	Front Panel Assembly A6 (Model 4110 or 4100)	6-13
VII	DRAWINGS	7-1/7-2

LIST OF ILLUSTRATIONS

<u>Fig. No.</u>	<u>Title</u>	<u>Page</u>
1-1	FM Volumax Automatic Peak Controller	1-1
1-2	Area of Potential FM Overmodulation (75- μ s Pre-Emphasis Curve)	1-3
1-3	Diagram and Oscilloscope Photos Showing Audio Peak Levels of Cymbal Clash with and with- out Pre- Emphasis	1-4
1-4	Simplified Block Diagram, FM Volumax Model 4100	1-4
2-1	Outline Drawing (Sheet 1 of 2 Sheets)	2-2
2-1	Outline Drawing (Sheet 2 of 2 Sheets)	2-3
2-2	Typical FM Volumax Installation Block Diagram	2-5
2-3	Typical Attenuator for FM Volumax Input Line (Schematic Diagram)	2-6
2-4	Transformer T1 or T3 Re-Strapping Connections for 150-Ohm Operation	2-8
3-1	FM Volumax Controls	3-0
4-1	FM Volumax Block Diagram	4-0
4-2	FM Volumax Amplitude Response	4-4
5-1	Locations of Circuit Boards and Chassis Parts in FM Volumax Unit	5-0

LIST OF ILLUSTRATIONS (cont)

<u>Fig. No.</u>	<u>Title</u>	<u>Page</u>
7-1	FM Volumax, Internal Interconnections	7-3/7-4
7-2	High Frequency Processor Board A1 or A4, Schematic and Parts Location Diagrams	7-5/7-6
7-3	Input-Output Board A2 or A5, Schematic and Parts Location Diagrams	7-7/7-8
7-4	Power Supply-AGC Board A3, Schematic and Parts Location Diagrams	7-9/7-10

LIST OF TABLES

<u>Table No.</u>	<u>Title</u>	<u>Page</u>
5-1	Power Supply Voltages	5-9
5-2	Ac Signal Voltages	5-9

SECTION I
INTRODUCTION

1-1. GENERAL

This manual provides instructions for the CBS Laboratories Model 4100 (Monaural) and Model 4110 (Stereo) FM Volumax* automatic audio peak controllers.

These instruments have been designed for use in FM and TV broadcasting applications in which the use of pre-emphasis is mandatory. Either instrument will enable the full modulation capability of the transmitter to be utilized with no risk of overmodulation. It replaces any limiter or clipper that may now be in use. When used with SCA** systems, it prevents crosstalk caused by overmodulation from entering into adjacent channels. It should be operated with well-controlled audio input levels such as provided by the CBS Laboratories Audimax* automatic level control.

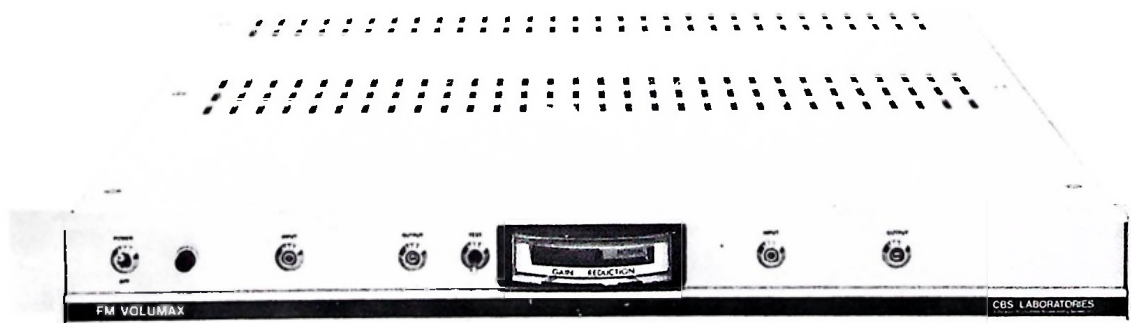

Figure 1-1. FM Volumax Automatic Peak Controller

* CBS Laboratories Trademark
** Subcarrier Authorization

INTRODUCTION

1-2. FUNCTIONAL DESCRIPTION

The Models 4100 and 4110 are late designs based on the foundation established in the earlier Model 410 FM Volumax unit. They extend the original technology to yield a cleaner, brighter sound while still retaining absolute protection against overmodulation.

A very familiar problem in FM and TV broadcasting is caused by the mandatory 75- μ s pre-emphasis curve (fig. 1-2). This is a long established requirement of the FCC for the improvement of the overall signal-to-noise ratio. At the time the FM and TV broadcasting standards were adopted, the long-term average spectral distribution of music signals showed a steady decline with frequency above 1,000 Hz. This meant that high-frequency pre-emphasis with subsequent de-emphasis at the receiver could be employed to improve the overall signal-to-noise ratio. However, in recent years, improvements and other changes in recording techniques in conjunction with social changes in musical style have led to increasing problems with the overmodulation caused by high-amplitude high-frequency program signals.

The FM Volumax unit solves this problem uniquely by quadruple-action control. Low-, middle-, and high-frequency portions of the program wave are independently processed and overall, instantaneous, final limiting is used to assure that no overmodulation will occur. See also figures 1-3 and 1-4.

1-3. PHYSICAL DESCRIPTION

The Models 4100 and 4110 FM Volumax units are housed in the same new slimline packages as the CBS Laboratories Audimax and a-m Volumax units.

INTRODUCTION

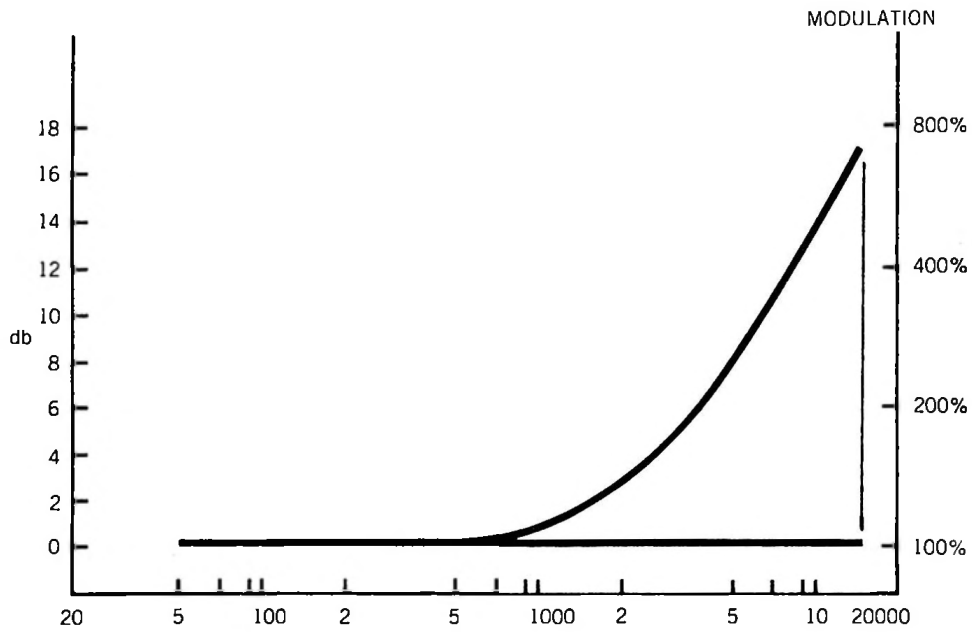

Figure 1-2. Area of Potential FM Over-modulation (75- μ s Pre-Emphasis Curve)

INTRODUCTION

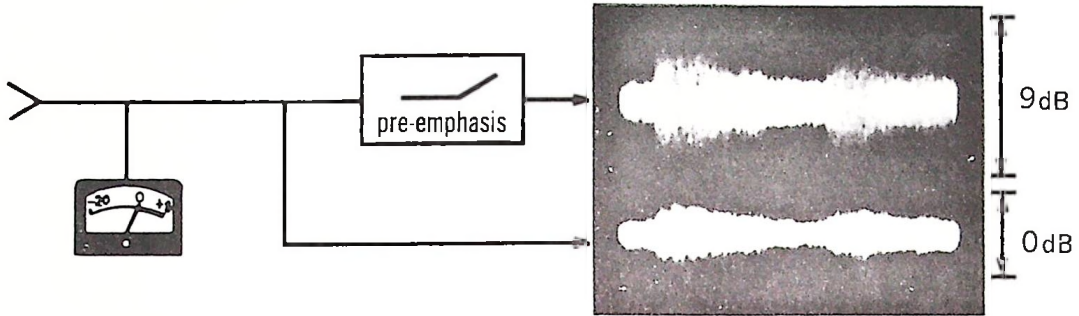

Figure 1-3. Diagram and Oscilloscope Photos Showing Audio Peak Levels of Cymbal Clash with and without Pre-Emphasis

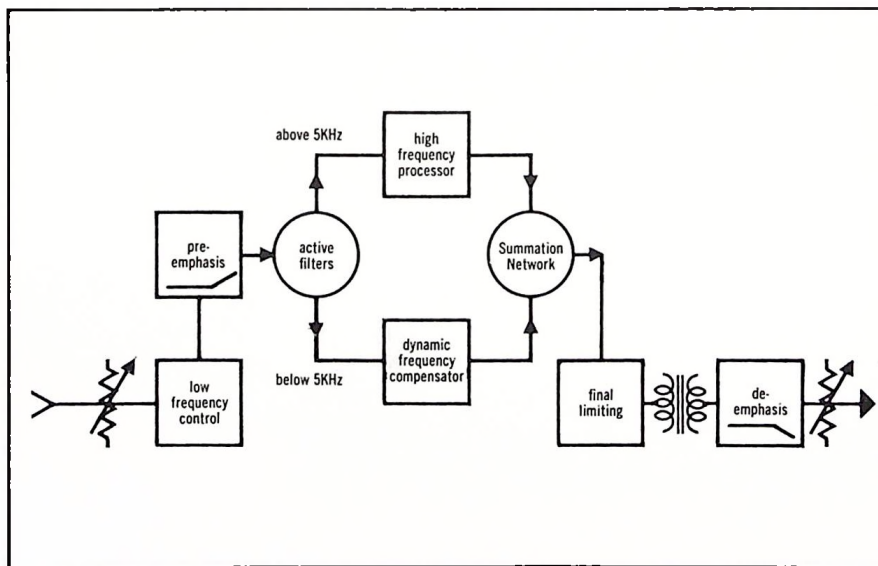

Figure 1-4. Simplified Block Diagram, FM Volumax Model 4100

INTRODUCTION

This package requires only 1-3/4 inches of height in a standard 19-inch rack and 18-1/2 inches of depth behind the front panel. The reliable solid-state circuitry is functionally packaged on three circuit boards in the monaural FM Volumax model and on five circuit boards in the stereo model. Both models are equipped with appropriate test points to speed the process of maintenance tests or troubleshooting procedures.

The entire unit slides forward on rack slides for easy servicing without disconnections from the transmitting system. Front panel controls are conveniently arranged and, in the stereo unit, are grouped according to channel-- left channel controls on the left of the unit and right channel controls on the right of the unit. A front panel meter indicates the relative degree of gain reduction.

The unit can be operated from either a 115-volt or 230-volt single-phase 50- or 60-Hz power source. On delivery, the unit is wired for 115-volt operation. Wiring changes for 230-volt operation are explained in paragraph 2-3.

1-4. WARRANTY

A standard warranty card has been included with your FM Volumax unit. To validate your warranty, complete and return the postcard section to CBS Laboratories as soon as possible.

1-5. SERVICE AND REPAIR

If there is difficulty in operating or maintaining your FM Volumax unit, call on your local authorized distributor from whom you originally purchased the unit. If you do not know the name and address of your local distributor, call

INTRODUCTION

CBS Laboratories, Professional Products Department, Stamford, Conn.,
06905, telephone (203) 327-2000.

1-6. SPECIFICATIONS

Input impedance	600 ohms, balanced or unbalanced; 10 kilohms or 150 ohms available on request.
Output impedance	600 or 150 ohms, balanced or unbalanced
Input level	-22 dBm to +8 dBm
Maximum peak output level	+28 dBm
Frequency response	± 1 dB, 50 - 15,000 Hz below limiting threshold. Variable as a function of level above limiting threshold, reaching the 75- μ s de-emphasis characteristic ± 1 dB at maximum level.
Harmonic distortion.	Less than 1%, below threshold of limiting, 50 - 15,000 Hz.
Attack time	Between 1 μ s and 2 ms, depending on program waveform.
Recovery time	200 ms (low frequencies) 5 ms (middle frequencies) 1 μ s or less (high frequencies)
Signal-to-noise ratio	Greater than 70 dB.
Tracking accuracy (stereo. model):	
Amplitude	Within 1/2 dB
Phase	Within 1.5 degrees
Maximum operating temperature	+55°C. (+130°F)

INTRODUCTION

Power requirements: 12 watts, 120/240 vac, 50/60 Hz
(Monaural)

15 watts, 120/240 vac, 50/60 Hz
(Stereo)

Dimensions Fits standard 19-inch rack, 1-3/4 inches
high, 18-1/2 inches deep.

Shipping weight:

Monaural model 13 pounds

Stereo model 14 pounds

SECTION II

INSTALLATION

2-1. UNPACKING

Carefully unpack your FM Volumax unit and examine it for evidence of damage that may have occurred in shipment. In the event of damage, file a claim immediately with the transportation carrier. If future transportation of the unit can be expected, save the shipping carton for re-use.

2-2. MECHANICAL INSTALLATION AND OPERATIONAL CONSIDERATIONS

The FM Volumax unit is shipped with a pair of rack slides which help to ensure a stable mounting in the rack and permit easy access to the internal parts of the unit if servicing should be necessary. A means of mounting the slides to the rack is detailed in figure 2-1.

The unit and its slides are designed to be mounted in a standard 19-inch electronic equipment rack. The front panel requires 1-3/4 inches of space in the height dimension, and 18-1/2 inches of depth behind the front panel are needed for the chassis. As for all transistor equipment, the unit must be installed in a reasonably well ventilated position with no high-heat-producing equipment beneath it.

CAUTION

The ambient temperature should not exceed 130°F (55°C).

Figure 2-2 is a block diagram of a recommended installation. When a Telco line is used to link the studio and transmitter sites, the FM Volumax unit is normally installed at the transmitter site, immediately before the audio input

INSTALLATION

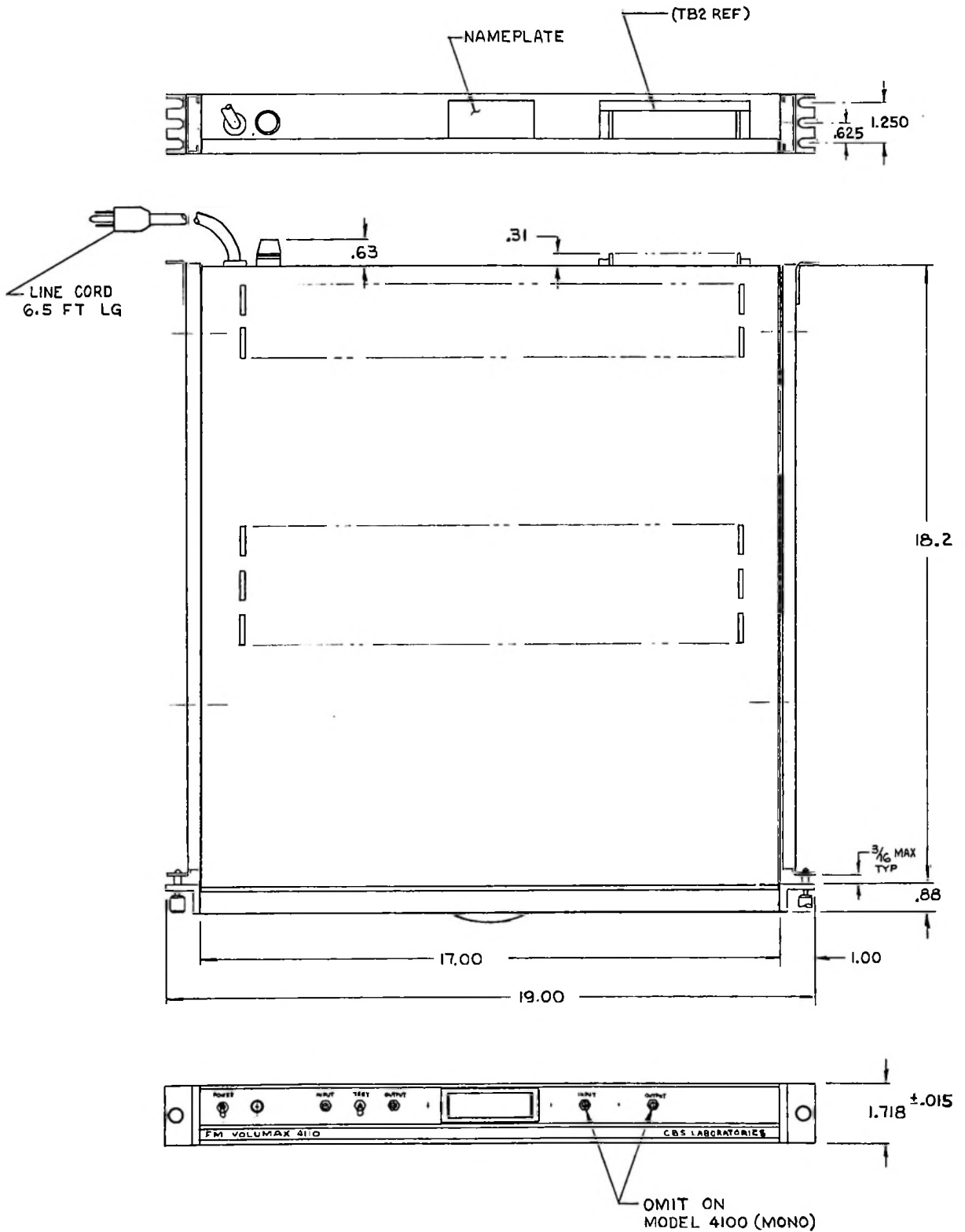
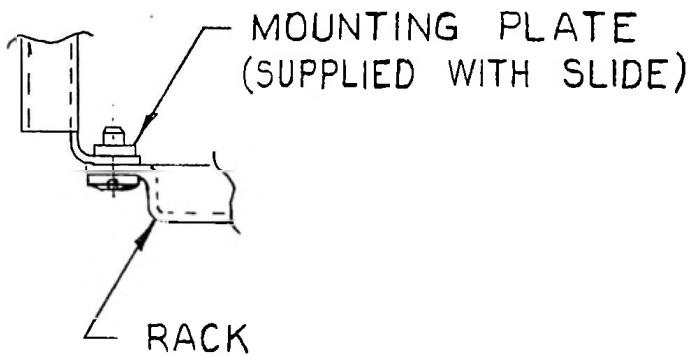
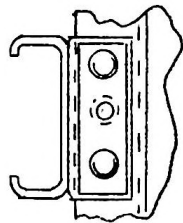

Figure 2-1. Outline Drawing (Sheet 1 of 2 Sheets)

INSTALLATION



DRILL OUT TAPPED HOLES IN RACK TO ACCOMMODATE USE OF MOUNTING PLATE.

Figure 2-1. Outline Drawing (Sheet 2 of 2 Sheets)

INSTALLATION

terminals of the transmitter. The FM Volumax unit has sufficient gain to correct for long-line and equalizer losses. However, if a pre-emphasized microwave STL* is used, the FM Volumax unit should precede the STL transmitter.

It should be remembered that the function of the FM Volumax unit is that of peak protection; this unit should not be used as a 'gain riding' device for a program line. Optimum operation will be obtained when the FM Volumax unit is supplied with uniform input levels such as those produced by the CBS Laboratories Audimax unit or other high-quality automatic gain control.

Input levels as low as -24 dBm can be accommodated. If high input levels are used -- as will be the case when an FM Volumax unit is connected immediately after an Audimax unit -- a fixed attenuator pad such as the "T" or "H" shown in figure 2-3 should be inserted immediately ahead of the FM Volumax unit. This will prevent excessive sensitivity in the control of the input.

2-3. POWER SOURCE

The FM Volumax unit is equipped with a power transformer which permits either 115 vac or 230 vac operation. As delivered, the unit is wired for 115 vac operation. If 230 vac operation is desired, make the following modifications at the internal terminal strip TB1 at the rear of the unit next to the rear panel.

- A. Remove the black/white lead from terminal 4 of TB1.
- B. Remove the brown and white leads from terminal 5 of TB1.

* Standard Transmission Link

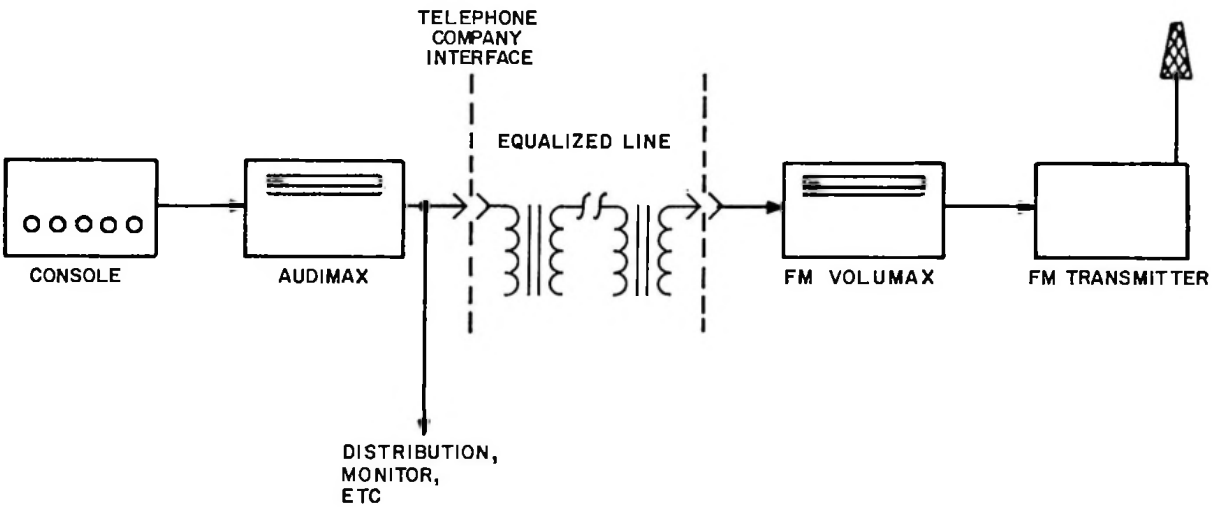
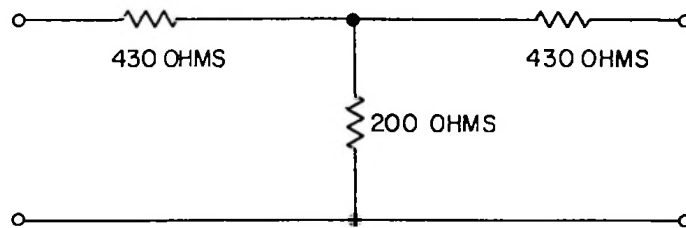
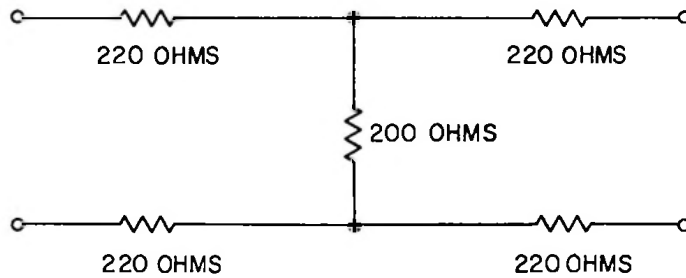

Figure 2-2. Typical FM Volumax Installation Block Diagram

INSTALLATION



A. SYMMETRICAL "T" 16dB PAD, 600 OHMS IN/OUT



B. SYMMETRICAL "H" 16dB PAD, 600 OHMS IN/OUT

Figure 2-3. Typical Attenuator for FM Volumax Input Line (Schematic Diagram)

INSTALLATION

- C. Connect the brown, white, and black/white leads together and sleeve the connection.
- D. Replace the original fuse with a type 3AG-0.15 amp (SLO-BLO)

2-4. ELECTRICAL CONNECTIONS

The 10-terminal strip TB2 at the rear of the chassis is used for all input and output connections to the FM Volumax unit. Use pins 1 and 2 for the monaural or left-channel-stereo input and pins 4 and 5 for the corresponding output. Similarly, for the stereo model, use pins 6 and 7 for the input to the right channel and pins 9 and 10 for the right-channel output. Pins 3 and 8 are chassis grounds.

To maintain correct stereophonic phasing (stereo model), the signals at terminals 1 and 6 should be in phase when a monaural signal is applied. Signals at terminals 4 and 9 will then also be in phase.

If the FM Volumax unit is terminated with an unbalanced load, terminals 4 and 9 should be used as the "high"-side terminals, and terminals 5 and 10 should be used for the common connections.

The standard FM Volumax unit is wired for 600-ohm operation. If 150-ohm operation is desired, consult the factory. A kit of parts to convert the output impedance to 150 ohms is available. Input impedance may be converted to 150 ohms by changing A1R5 (A5R5) to 150 ohms.

OPERATIONAL SET-UP

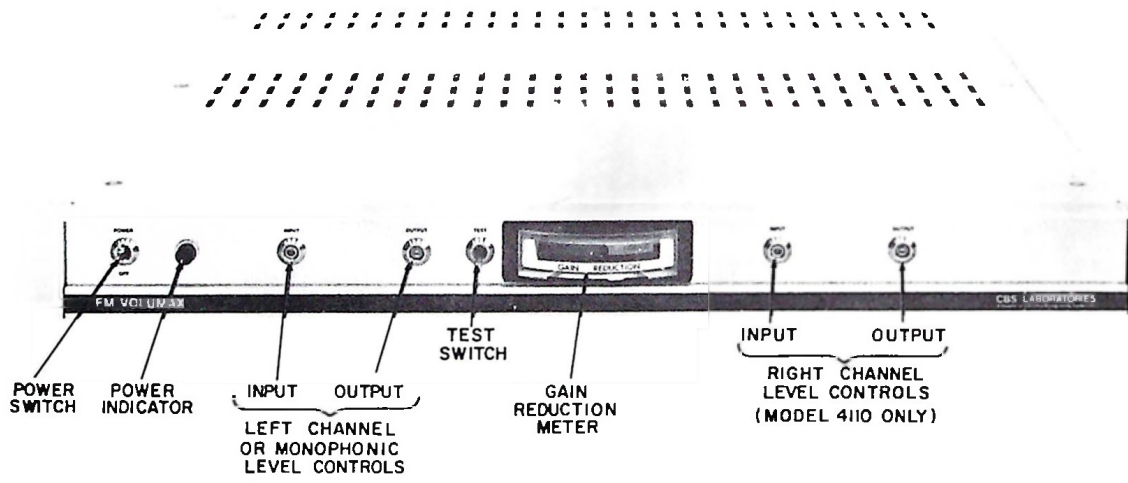

Figure 3-1. FM Volumax Controls

SECTION III

OPERATIONAL SET-UP

3-1. GENERAL

All of the necessary operational controls are located on the front of the FM Volumax unit as shown in Figure 3-1. In the stereo version, input and output controls for the left channel are located at the left of the meter and input and output controls for the right channel are located at the right of the meter. In the monaural version, all controls are located at the left of the meter, and, in either model, the power switch is located at the extreme left end of the front panel. A switch to control an internal broad-band limiter is located on the left side of the front panel in either model. The gain reduction meter in the center of the panel measures the amount of broad-band gain reduction and should be used as a general guide in adjusting the input level controls.

3-2. SET-UP OF STEREOPHONIC FM VOLUMAX UNIT

A. After all input, output, and ground connections have been made as in Section II of this manual, turn both the INPUT level and OUTPUT level controls fully counterclockwise. Then place the POWER switch in the "on" position.

B. Apply a 400-Hz left channel sine-wave at normal reference level to the FM Volumax unit. Adjust the left INPUT level control for a GAIN REDUCTION meter deflection to the red/green junction.

C. Move the TEST switch up to the TEST position and turn the left OUTPUT level control clockwise as far as necessary to produce the maximum desired left channel modulation. This step provides a precise setting of the

OPERATIONAL SET-UP

modulation level with a pure sine wave. In operational use, small errors in the pre-emphasis network plus phase shifts in the transmitter may combine to cause slight overmodulation with complex program waveforms. If this occurs, a slight re-adjustment of the OUTPUT level control may be necessary.

NOTE

The phase-shift problem may be reduced at installations where it is easy to disable or remove the pre-emphasis network from the transmitter. If this is done, the de-emphasis network at the FM Volumax output must also be removed. The de-emphasis network can be effectually removed by disconnecting C9 and placing a jumper across L1 on each high-frequency processor board (A1 and A4).

D. Remove the left channel signal and place the TEST switch in the "off" position.

E. Apply a 400-Hz right channel sine wave at normal reference level to the FM Volumax unit. Adjust the right INPUT level control for a GAIN REDUCTION meter deflection to the red/green junction.

F. Place the TEST switch in the TEST position and turn the right OUTPUT level control cw as necessary to produce the maximum desired right channel modulation.

OPERATIONAL SET-UP

G. Place the TEST switch in the "off" position, remove the 400 Hz signal, and apply stereo program signals to the instrument. Adjust the program master gain control as required to cause the GAIN REDUCTION meter to indicate in the green (NORMAL) area with occasional peaks producing deflections into the red (HEAVY) area.

NOTE

The design calibration of the meter is, of necessity, based on subjective considerations. Hence, not all users will desire operation with the same degree of limiting action. A setting for heavy limiting action will produce higher average modulation but with a reduction of dynamic range.

In the event that very heavy limiting action is desired, advantage may be taken of existing provisions for an optional meter compression circuit on the power supply/AGC board A3. Add a 470-ohm, 1/4-watt resistor in the board position marked R32 and add a 1N3121 germanium diode at the position marked CR4. Observe the diode polarity marked on the board. The meter will then indicate an additional "on scale" compression of 2 to 3 dB. When calibrating the unit, be sure to disable this meter-compression circuit by

OPERATIONAL SET-UP

opening R32 or CR4 for the duration of the calibration procedure.

3-3. SET-UP OF MONOPHONIC FM VOLUMAX UNIT

A. After all input, output and ground connections have been made as in Section II of this manual, rotate the INPUT level and OUTPUT level controls fully counterclockwise and place the POWER switch in the "on" position.

B. Apply a 400-Hz sine wave at normal reference level to the FM Volumax unit. Adjust the INPUT level control as required to cause the GAIN REDUCTION meter deflection to appear at the red-green junction.

C. Move the TEST switch up to the TEST position and turn the OUTPUT level control clockwise as far as necessary to produce a modulation level of 100 percent or any other desired maximum. Read the Note on phase shift errors immediately following subparagraph C of the stereophonic unit set-up procedure (paragraph 3-2). This Note also applies to the monophonic unit.

D. Place the TEST switch in the "off" position and replace the sine-wave test signal with a normal program.

E. If necessary, readjust the INPUT level as needed to keep the meter deflection primarily in the green area with occasional peak deflections into the red area. Read the Note on meter calibration at the end of paragraph 3-2. This Note also applies to the monophonic unit.

3-4. PROOF-OF-PERFORMANCE MEASUREMENTS

Generally accepted procedures for performing Proof-of-Performance tests usually call of these measurements to be made "without compression".

OPERATIONAL SET-UP

In the FM Volumax unit, the compression action can be disabled by placing the TEST switch in the TEST position; however, in so doing, care must be taken to insure that the instrument is not overloaded.

The following technique is recommended as the most satisfactory method of proof-of-performance measurements.

A. Frequency Response

NOTE

See also subparagraph B. The frequency response and distortion tests may be performed concurrently.

(1) With the TEST switch in TEST position, apply a 100-Hz tone through a calibrated attenuator at a level sufficient to cause the output of the FM Volumax unit to be clipped. Adjust the output level for transmitter modulation of slightly over 100 percent. In the stereophonic case, the measured channel output should be set to its relative maximum output level.

(2) Reduce the input as needed for 100 percent modulation. No clipping should now occur.

(3) Measure the system frequency response by incrementally increasing the input-signal frequency and adjusting the calibrated attenuator as needed to maintain a constant percentage of modulation. The readings of the calibrated attenuator plotted against frequency should be the inverse of the standard 75-microsecond pre-emphasis curve.

(4) Repeat the above measurements for other desired modulation levels.

OPERATIONAL SET-UP

NOTE

Do not attempt to apply maximum level at frequencies above 1 kHz. The combination of Volumax pre-emphasis, limited amplifier headroom, zener clipping, and the de-emphasis network will produce a falling characteristic and considerable distortion, even with the AGC action disabled.

B. Distortion

Harmonic distortion in the FM Volumax unit has been minimized for operation in the normal limiting mode. It may not be quite as low when the unit is operated at high level without compression; however, as long as the unit is not clipping, the distortion should remain within specifications. Distortion may be measured with the TEST switch in the TEST position at the same time that the frequency response is being measured.

THEORY

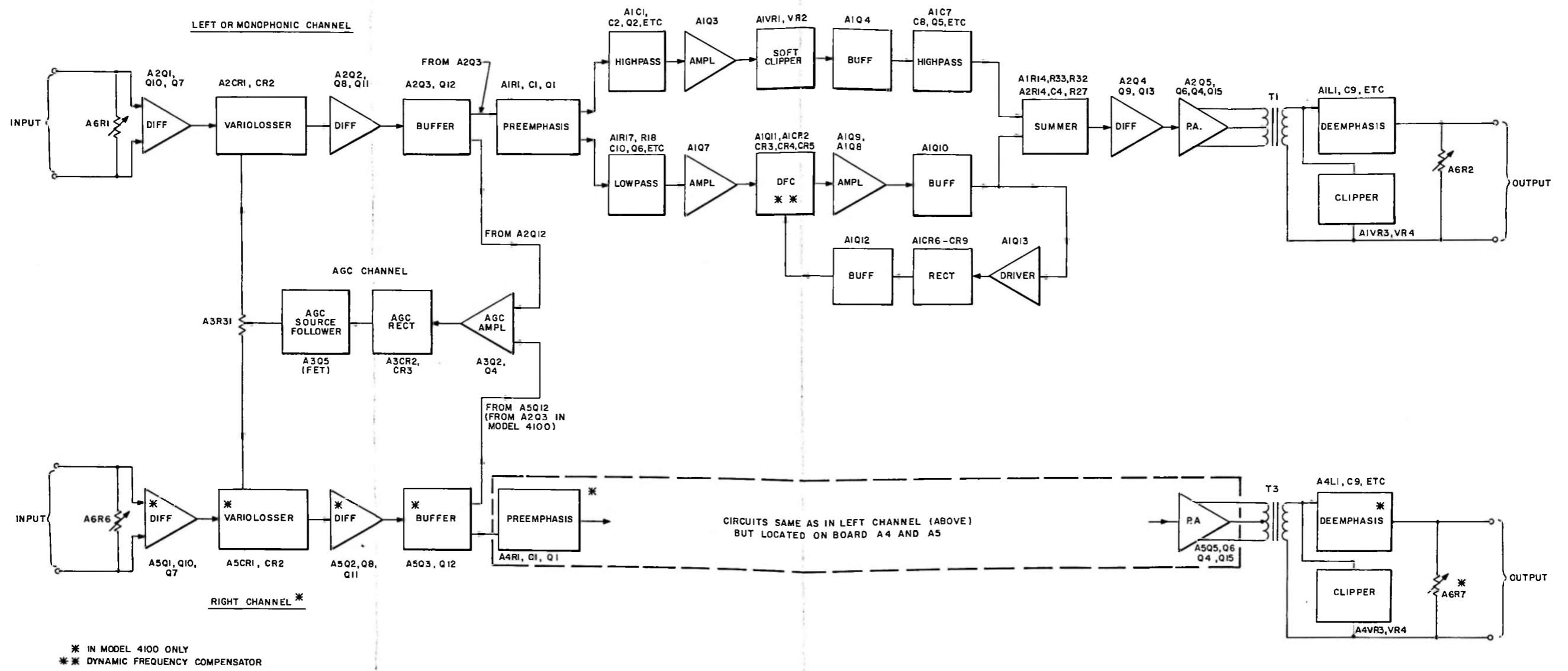

Figure 4-1. FM Volumax Block Diagram

SECTION IV
THEORY OF OPERATION

4-1. GENERAL

The FM Volumax Models 4100 and 4110 are functionally similar to conventional peak limiters in that either unit prevents the overmodulation of a radio-frequency carrier by acting on instantaneous program peaks. The FM Volumax circuit, however, has been designed to overcome the limitations of conventional peak limiters and, in addition, contains patented circuits which anticipate the effects of transmitter pre-emphasis. The result is a peak controller for FM broadcasting that permits a very high level of average modulation, positively prevents over-modulation, and yet maintains a clean bright sound without "pumping" or other audible distortion.

A. The Problems

A shortcoming of conventional limiters is that program material with a high peak factor drives the limiter further into a gain reduction than material with a low peak factor, even though both signals may have equal VU levels. Consequently, high-peak-factor signals are lower in average level at the output of a conventional limiter.

In another shortcoming, most conventional limiters must moderate audible pumping by the use of comparatively long recovery times. Consequently, immediately after each large peak in the signal, the program is transmitted at less than optimum gain. This reduces the average modulation level and wastes a valuable capability of the transmitter.

THEORY

Finally, with conventional limiters, the effect of pre-emphasis in the FM transmitter -- a problem unique to FM and TV audio broadcasting -- can upset attempts to control overmodulation. If the limiter operates before pre-emphasis, the boosts in response by 5 dB of 3-kHz signals, 14 dB of 10-kHz signals, and 17 dB of 15-kHz signals preclude accurate control of high-frequency peak overmodulation. If the limiter operates after pre-emphasis, overmodulation will be prevented but at the expense of average level loss and potentially severe pumping effects. In either situation, the high levels of high-frequency energy found in cymbal clashes, muted trumpets, speech silibants, et cetera, are difficult to control without overmodulation.

B. The Solution

FM Volumax overcomes these problems in an esthetically acceptable manner by precisely controlling the audio signal in four distinct stages.

First, wide-band AGC controls average peaks in a conventional manner. The attack time constant is held within 1 to 2 milliseconds so that transients with any faster rise times are passed along to subsequent stages of control. The recovery time is also quite fast -- at the syllabic rate of about 150 milliseconds -- to permit the retention of high average levels.

Next, the signal is pre-emphasized to the standard pre-emphasis curve and active filters divide the signal into two bands above and below 5 kHz. Dynamic frequency compensation is used for the band below 5 kHz. Meanwhile, the band above 5 kHz passes through a very fast limiter (a variation of soft clipping) and is filtered. Thereupon the signals from the two bands are summed. The filtering and summation take place both concurrently and independently.

THEORY

Finally, instantaneous diode limiting is used to prevent overmodulation from being caused by initial transient peaks with rise times faster than 1 ms. Following de-emphasis and the OUTPUT level attenuator, the controlled signal proceeds to the transmitter where pre-emphasis restores the accurately controlled 100-percent modulation point. Frequency response families illustrating this action appear in figure 4-2.

A front panel meter indicates the degree of AGC control and is a useful indication of how much limiting is being applied to a particular signal. A TEST switch, when actuated, clamps all of the internal variable-gain stages, and permits the modulation level to be set or proof-of-performance measurements to be made.

4-2. INPUT SECTION (BOARD A2 OR A5)

(See figures 4-1 and 7-3.)

The input signals to the FM Volumax unit at TB2 are terminated on board A2 or A5 in an appropriate load, R5, and pass to the front panel INPUT level control, A6R1 or A6R6. (See also figure 7-1.) From the front-panel control, they return to A2 or A5 where they are capacitively coupled into a differential amplifier Q1, Q10. In the stereo model, board A2 and A6R1 process left-channel signal while board A5 and A6R6 process the right-channel signal. In the monophonic model, which has neither A5 nor A6R6, the single-channel signal is processed by A2 and A6R1.

On either A2 or A5, the differential amplifier Q1, Q10 has a high common mode rejection ratio to eliminate common mode hum, noise, etc., from the

THEORY

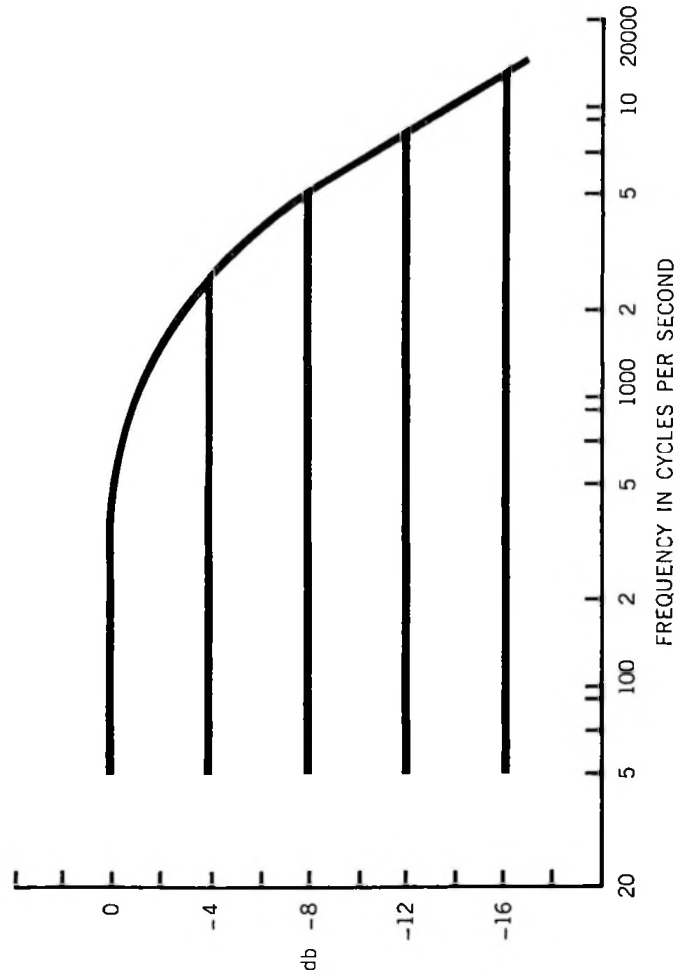

Figure 4-2. FM Volumax Amplitude Response

THEORY

incoming line, and also obviates the need for an input transformer. Transistor Q7 is a constant current source which suitably biases the differential amplifier.

Subsequently, the signals are applied to a Variolossor, CR1, CR2 (a pair of matched silicon diodes), whose attenuation to small signals varies as a function of a control current derived on board A3. The Variolossor and its associated circuitry on A3 constitute the AGC subchannel, described in Section I, which limits the input signal on a broad band-basis before any further processing.

Another differential amplifier, Q2, Q8, Q11, and the emitter-follower buffers, Q3, Q12, complete the input section. The audio signal path then enters the high-frequency processor board A1 (left channel or monaural) or A4 (right channel, stereo only) and simultaneously drives the AGC amplifier section on board A3.

4-3. AGC AMPLIFIER (BOARD A3)

(See figures 4-1 and 7-4.)

Two high-gain AGC amplifiers, Q2, Q4 on board A3, use signals from the input section of A1 or A5 to drive biased rectifiers, CR2, CR3. In the monophonic model, 4100, the two amplifiers sample the two sides of the balanced audio from A1. In stereo units (4110), the interconnections are such that each AGC amplifier samples one of the two separate channels. Rectifier bias set by the potentiometer R17 determines the point at which AGC action begins along the input/output curve. The outputs of the two rectifiers are summed at the gate of the field effect transistor (FET) Q5, while the AGC time constant is

THEORY

determined by R20 and C9. The FET is connected as a source follower to provide a low source-impedance drive for the front-panel GAIN REDUCTION meter, A6M1 and the Variolosses on board A1 (or A5) which was described in paragraph 4-2. The potentiometer R24 sets the amplitude of the quiescent (no-signal) current which passes through R28 to the Variolosses(s), while the potentiometer R31 (stereo model only) is used to balance the AGC control current for the left and right channel Variolosses.

4-4. HIGH FREQUENCY PROCESSOR (BOARD A1 OR A4)

(See figures 4-1 and 7-2.)

Following AGC control on A2 or A5, the audio signals pass to A1 or A4 where they are first pre-emphasized to the standard 75-microsecond curve by R1, C1 and are buffered by the emitter follower Q1. In the stereo model, A1 is used for the left channel and A5 is used for the right channel. In the monophonic model, A1 is used for the single channel and A5 is omitted.

The insertion of pre-emphasis at this point ensures that the subsequent processing will anticipate and correct for the ultimate effect of the transmitter pre-emphasis.

Next, the signal is divided into two bands by active filters: Q2, C2, C3, R4, and R5, constituting a high-pass filter; Q6, R17, R18, C10, and C11, constituting a low-pass filter. The crossover frequency is 5 kHz, and each filter rolls off at 12 dB/octave, permitting essentially independent and parallel processing of signals above and below 5 kHz.

THEORY

A. Signals above 5 kHz

The output of the high-pass filter is amplified by Q3 and is applied to a soft clipper, VR1, VR2, C21. The soft clipper acts as a very fast limiter for those signals whose pre-emphasized peak factor above 5 kHz exceeds a threshold determined by the amplifier emitter potentiometer R8. While it is true that some harmonic and intermodulation distortion products are created by this method, the fact that only signals above 5 kHz are so processed precludes the generation of any significant harmonic products below 15 kHz. Also, a second active high-pass filter formed by C7, C8, R11, R12, and Q5 removes any undesirable intermodulation products below 4 kHz. The emitter follower Q4 buffers the output of the soft clipper and the input to the second high-pass filter.

B. Signals below 5 kHz

Simultaneously, the output of the low-pass filter is acted upon by the dynamic frequency compensator (DFC) circuit. The heart of the DFC is a variable-reactance circuit: Q11, CR2, CR3, CR4, CR5, C13, and R24. At low input levels, this circuit has a flat frequency response and merely passes signal through to the output at TP4. For higher input levels, the circuit has a high-frequency roll-off characteristic of about 6 dB per octave with a variable break-point determined by a control voltage in such a way as always to limit the pre-emphasized signal to a pre-determined amplitude.

When Q11 is fully cut off, approximately 10 ma of current flows through the four DFC diodes, and capacitor C13 sees an effective ac ground. Resistor R24 and capacitor C13 form a low-pass RC filter with a corner frequency of about 1 kHz. When Q11 is fully "on" (saturated), the 10 ma of current flows

THEORY

through this transistor rather than the diodes. Thus, C13 floats and the frequency response does not roll off. At intermediate points in the active region for Q11, the ac impedance of the diodes is a function of the control voltage at TP6. Therefore, the roll-off characteristic is also a function of the control voltage at TP6.

The DFC circuit operates as a closed loop in which the control voltage is generated by using the potentiometer R31 to sample the output of the emitter follower Q10 and driving the full-wave rectifier CR6, CR7, CR8, and CR9 by means of the sample voltage amplifier Q13. Potentiometer R35 sets the quiescent bias for Q11 and Q12. Potentiometer R39 sets the dc level of the control voltage. Capacitor C17 determines the DFC recovery time, 5 ms.

C. Recombination

The wide-band, processed signals are recombined at TP5 through R14 and R33. The potentiometer R32 is used to balance the outputs of the two independent processors so that the low-level frequency response is flat.

4-5. OUTPUT SECTION (BOARD A2 OR A5)

(See figures 4-1, 7-3, 7-1, and 7-2.)

The processed and recombined signal is amplified to line level by the output section and is coupled to a floating output by an output transformer. The output section comprises Q4, Q5, Q6, Q9, Q13, Q14, and Q15 on board A2 (left channel or monaural) or board A5 (stereo only, right channel). The output transformers are located on the chassis and are fully shown in figure 7-1. The left channel or monaural output transformer is T1 and the right channel output

THEORY

transformer (stereo model only) is T3. Following safety limiting and de-emphasis on board A1 or A4 (VR4, VR3, L1, R15, R16, C9, R47), the signal is attenuated to the desired OUTPUT level by A6R2 (left channel or monaural) or A6R7 (right channel -- stereo only) on the front panel.

4-6. POWER SUPPLY (BOARD A3)

(See figures 7-4 and 7-4.)

Either 115 vac or 230 vac nominal may be applied to the primary of the power transformer T2 (figure 7-1) to yield 50 vac which is rectified by the full-wave bridge CR1 (figure 7-4) to derive an unregulated supply of 28 vdc. The series pass NPN transistor Q1, whose base is referenced to the zener diode VR1, provides a regulated B+ supply of 19.4 vdc while the series pass PNP transistor Q3, referenced to VR2, provides a regulated B- supply of 14.4 vdc.

MAINTENANCE

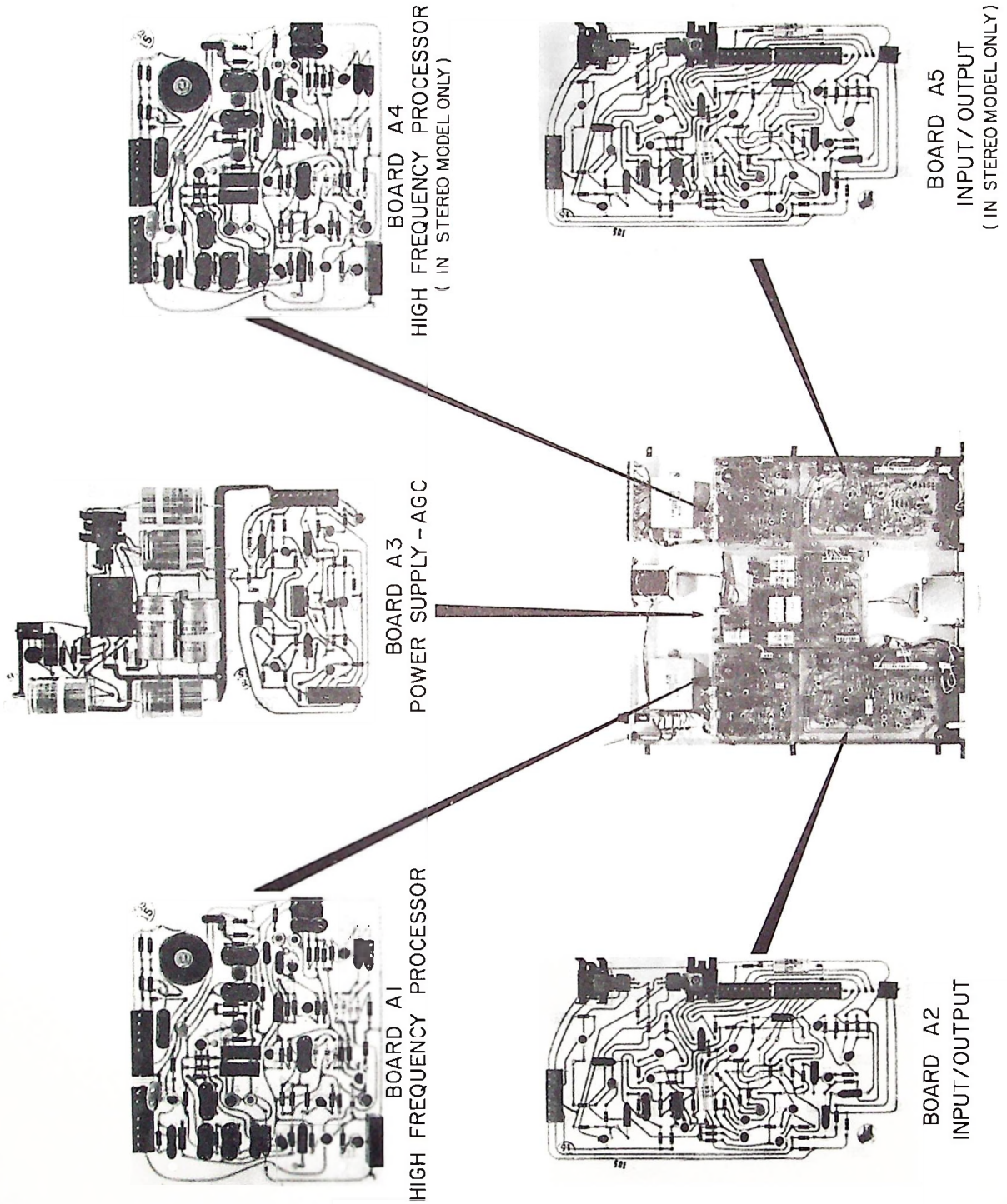

Figure 5-1. Locations of Circuit Boards and Chassis Parts in FM Volumax Unit

SECTION V
MAINTENANCE

5-1. GENERAL

A. Access to Internal Components

If necessary to reach the internal parts of the FM Volumax unit, unscrew the bolts which lock the rack slides at the sides of the unit. Slide-out the unit on the rack slides until the unit locks itself in position; then remove the top cover. See figures 5-1 and 7-1 for panel and chassis parts locations and figures 7-2 through 7-4 for circuit board parts locations. Figures 5-1 and 7-1 also identify and show the locations of the circuit boards.

B. Troubleshooting Method

The troubleshooting of any apparent malfunction of the FM Volumax unit should always begin with a check of the power supply. Dc voltages (as measured with a VTVM) should fall within the limits shown in table 5-1 at the end of this section.

CAUTION

Accidental shorting of either the +20v or -15v supply might cause the respective regulating transistor A3Q1 or A3Q3 to develop a collector-emitter short. This would destroy the regulation and allow unregulated dc to be applied to the signal circuits. If either power supply voltage is significantly high and excessive ripple is present, the respective regulating transistor (A3Q1

MAINTENANCE

or A3Q3) may be shorted. If ripple is excessive, but the voltages are correct, check for open or leaky power supply filter capacitors.

If the power supplies are satisfactory, proceed with the following checks for the isolation of other trouble:

(1) In the extreme case of no output from an audio channel, check input and output connections. Inspect the connections to the printed circuit boards for a possible open lead. If this visual inspection does not indicate any defects, stage-by-stage signal tracing will be necessary.

(2) To determine at what circuit point the signal is lost or degraded, turn the appropriate INPUT level and OUTPUT set controls fully clockwise and apply a 1 kHz signal at 10 mv to the appropriate channel input terminals of the FM Volumax unit. Table 5-2 at the end of this section gives the proper ac voltages at various points in the signal path with respect to chassis ground. This table is arranged in advancing signal-stage order.

(3) When the point of signal loss or other malfunction is reached, see paragraphs 5-2 through 5-9. The alignment procedure (paragraph 5-2) may eliminate the trouble if the signal is not lost. If signal is lost or further troubleshooting is necessary for other reasons, proceed to paragraphs 5-3 through 5-9.

5-2. ALIGNMENT PROCEDURE

The following is a simplified version of the CBS Laboratories factory alignment procedure, and can be used to bring the FM Volumax characteristics

MAINTENANCE

back within specifications after long-term aging or component changes. Under normal circumstances, it should not be necessary to realign the unit unless component changes are made.

A. Control Pre-Settings

(1) Turn power on and allow a warmup. During warmup, set circuit-board potentiometers as follows:

<u>Potentiometer</u>	<u>On Board(s)</u>	<u>Position</u>
R32, R35, R39	A1, A4	Mid-range
R10, R30	A2, A5	Mid-range
R12, R17, R25, R31	A3	Mid-range
R8	A1, A4	Fully ccw
R31	A1, A4	Fully cw
R24	A3	Fully cw

(2) Turn front-panel INPUT level and OUTPUT level controls fully clockwise.

(3) Set the voltage at TP6 (boards A1 and A4) to $10v \pm 0.2v$ using R35 (same boards). Set the voltage at the collector of Q12 (boards A1 and A4) to $9.5v \pm 0.2v$ by using R39 (same boards).

(4) Adjust R12 (board A3) as necessary for the front-panel GAIN REDUCTION meter to read full scale right.

(5) Place the front-panel TEST switch in TEST (upper) position.

MAINTENANCE

B. Broad-Band AGC Alignment

(1) Drive both stereo inputs (or the single monaural input) with a 200-Hz signal at a level of 4 mv rms. Measure the output(s). Each should be approximately 1.1v rms.

(2) Set the Variolossor bias (boards A2 and A5) by turning R24 on board A3 counterclockwise until the respective outputs drop 3 dB $\pm 1/2$ dB.

(3) Slowly increase the input signal level(s) until the output(s) just begin to be clipped. Record these input level(s). They should be 12v rms $\pm 1.3v$. Return the TEST switch to the 'normal' position (down) at the end of this step.

(4) Alternately adjust the input level and R17 on board A3 until the GAIN REDUCTION meter reading is at the red-green junction and the output level(s) are 2 dB below the value measured in step (3).

(5) Check the ripple at TP7 on board A3 and adjust R25 on this same board for equal ripple on consecutive half cycles (at a 400 Hz rate).

C. DFC Alignment

(1) Apply a 450-Hz signal to the left or monaural channel input at a level sufficient to bring the GAIN REDUCTION meter reading to the red/-green junction. Record the output level. Do not apply any input to the right channel in the stereo model.

(2) Switch to a 4.5-kHz input at the same input level. Turn R31 on board A1 counterclockwise until the output level is 5 dB below the value measured in step (1).

MAINTENANCE

(3) If a stereo unit, repeat steps (1) and (2) for the right channel (board A4), omitting the input from the left channel.

D. High-Frequency Clipper Alignment

(1) Apply a 10-kHz signal at 4 mv rms to the left or monaural input only.

(2) Turn R8 on board A1 clockwise until the signal level at TP2 (board A1) is 0.70v rms.

(3) If a stereo unit, repeat steps (1) and (2) for the right channel (board A4).

E. Amplitude Alignment

(1) Apply a 150-Hz signal at 4 mv to the left or monaural input only.

(2) Switch the test signal between 150 Hz and 15 kHz at the same input level. Then adjust R32 (board A1) as needed to match the output at 15 kHz with that measured at 150 Hz. Adjust R32 while at the 150 Hz input.

(3) If a stereo unit, repeat steps (1) and (2) for the right channel (board A4).

F. Distortion Minimization

(1) Apply a 50-Hz signal at 30 mv to the single-channel input (monophonic model) or both inputs (stereo model).

(2) Adjust R30 on Boards A2 (and A5) for minimum distortion at the output (s) (0.5 percent typical).

(3) Apply a 3-kHz signal to both (or the single) inputs at a level that causes the GAIN REDUCTION meter to read in the middle green region.

MAINTENANCE

(4) Measure the harmonic distortion at TP3 on boards A1 and A4, and adjust R10 (boards A2, A5) for minimum distortion.

G. Stereo Unit Balance Adjustments

Apply 400-Hz signals to both inputs at a level to cause the GAIN REDUCTION meter to read at the red/green junction. Adjust R31 on board A3 so that the two output levels are matched within 1/4 dB.

5-3. TROUBLESHOOTING INPUT SECTION (BOARD A2 OR A5)

If signal is present at the collectors of Q1 and Q10 but is too low or too high at the bases of Q2 and Q11, measure the quiescent control voltage at TP2. This should be $-0.5\text{v} \pm 0.1\text{v}$. If the control voltage is incorrect, the potentiometer R24 on board A3 should be adjusted according to the alignment procedure in paragraph 5-2. If the attempt to set R24 fails to correct the problem, suspect the Variolossor diodes CR1 and CR2 on board(s) A2 (and A5). If these diodes must be replaced, select matched diodes for each replacement pair; the forward voltage drops should be within 10 mv of each other at 1 ma of forward current. The remainder of the circuitry in the input section(s) of the equipment is conventional. If Q2 or Q11 are replaced, select R11 and/or R24 such that the voltage measured between the collectors of Q2 and Q11 is less than ± 0.5 vdc.

5-4. TROUBLESHOOTING HIGH FREQUENCY CONTROL SECTION (BOARD A1 OR A4)

The action of the 75-microsecond pre-emphasis network R1, R2, and C1 on board A1 or A4 should be apparent when monitoring the emitter of Q1 on the same board and sweeping the frequency of the input signal. Transistor stages

MAINTENANCE

Q2 and Q6 are complementary active filters which divide the frequency band at 5 kHz. This action should be apparent by examining the respective high and low frequency outputs at TP1 and TP3.

The high-frequency side (Q2) is followed by clipping and filtering. This action should be apparent by comparing the signal at TP2 with that at TP1 at frequencies above 5 kHz. The amplitude of the input should be sufficient to cause an indication on the GAIN REDUCTION meter.

Similarly, the mid-highs are acted upon by the dynamic frequency compensation (DFC) circuit in a proprietary CBS Laboratories technique. This action can be observed by comparing the signal at TP6 with the signal at TP3 while the mid-high region (1-5 kHz) is being swept at a high enough level to cause an indication on the GAIN REDUCTION meter.

The foregoing checks should isolate any trouble to a narrow region.

5-5. TROUBLESHOOTING OUTPUT SECTION (BOARD A2 OR A5)

If signal is present at J3-9 but not at TP4, TP6 on board A2 or A5, check Q4 and Q13. If signal is present at TP4, TP6, but not at the primary of the output transformer T1 or T3, check transistors Q5, Q6, Q14, and Q15. If signal is present but too low at T1 or T3, either Q6 or Q15 may be at fault, since each operates in the class A mode.

5-6. TROUBLESHOOTING AGC SECTION (BOARD A3)

To check for proper AGC action, first set the front-panel TEST switch in the "off" (lower) position and set the INPUT level control(s) fully clockwise. Then apply a 1-kHz signal to either or both FM Volumax channels. Increase the

MAINTENANCE

input until the GAIN REDUCTION meter reading just begins to move toward the left. Note the appropriate output level(s) across the 600 ohm load(s). Finally, increase the input 10 dB; the output should increase less than 2 dB.

(1) If the GAIN REDUCTION meter reading moves downscale during this test but the output is not compressed as indicated above, check the Variolossor diodes CR1 and CR2 on board A2 or A5.

(2) If the GAIN REDUCTION meter does not move downscale, monitor the voltage at TP7 on board A3 while varying the input level as described above. Here the voltage should vary from about 0.0 vdc at an input level of 30 mv to about -0.3 vdc at input level of 100 mv (10 dB greater). The FET A3Q5 is to be suspected if the gate voltage at A3TP7 varies as previously described but no gain reduction occurs. If the voltage at A3TP7 does not vary as described, there are two other possibilities:

(a) The voltage may vary, but over a different range than described. In this case, potentiometer A3R17 is incorrectly set; see the alignment procedure, paragraph 5-2.

(b) There may be no voltage variation. In this case, no control voltage is being generated. Adjust the 1-kHz input level to 30 mv. The signal level at A2J3-4, 8 or A5J3-4, 8 should then be 1.2v. The ac signal levels at the bases of A3Q2, A3Q4 should be approximately 75 mv. Next, measure the voltages at A3TP2, A3TP6; each should be 2.5 vac. Correct voltages here in combination with no control voltage indicates defective diodes A3CR2 and/or A3CR3. If, after any changes in the AGC section, the meter reading with no signal applied is not at reference (full scale), see paragraph 5-7.

MAINTENANCE

5-7. TROUBLESHOOTING GAIN METER CIRCUIT

If, after thorough warmup with no input, the rest position of the GAIN REDUCTION meter is not precisely at full scale, it can be reset using R12 on board A3.

TABLE 5-1. POWER SUPPLY VOLTAGES

<u>Supply</u>	<u>Correct Output</u>	<u>Maximum Ripple</u>
+20v	+19.4v \pm 1v	10 mv rms
-15v	-14.5v \pm 3/4v	5 mv rms

TABLE 5-2. AC SIGNAL VOLTAGES

NOTE

All measurements are made to chassis ground.

<u>Test Point</u>	<u>Correct Voltage</u>
INPUT SECTION -- BOARD A2 OR A4:	
TP1	Ground
Bases Q1, Q10	Unbalanced input, 6.4/1.8 mv
Collectors Q1, Q10	11.0 mv
Bases Q2, Q11 (Variolosses)	3.0 mv
Emitters Q3, Q12, (TP3, TP5)	420 mv

MAINTENANCE

TABLE 5-2. AC SIGNAL VOLTAGES (cont)

<u>Test Point</u>	<u>Correct Voltage</u>
HIGH FREQUENCY SECTION -- BOARD A1 OR A4:	
Emitter Q1	27 mv
TP1	1.7 mv
Emitter Q4	30 mv
TP2	4.4 mv
TP3	27 mv
Collector Q8	55 mv
Collector Q9	420 mv
TP4	420 mv
TP5	280 mv
OUTPUT SECTION -- BOARD A2:	
TP1	Ground
Base Q4	240 mv
Base Q13	180 mv
Collectors Q4, Q13	660 mv
TP4, TP6	175 mv
J1-4, J1-8	2.0 mv
Across 600-ohm output load	2.8 v rms (approx +11 dBm)

SECTION VI

PARTS LISTS

6-1. GENERAL

This section contains parts lists for the complete FM Volumax. Each list gives the circuit designation of the part, an electrical description, a reference to the manufacturer where significant, and that manufacturer's part number. In all cases, the use of original manufacturers' parts is recommended for any necessary replacements. If the part cannot be readily obtained, contact the Professional Products Department at CBS Laboratories to procure it.

6-2. RESISTORS

Except where otherwise indicated in the parts lists, all resistors used in the FM Volumax are carbon composition, 1/4 watt, plus or minus 5%.

6-3. DIODES AND TRANSISTORS

When replacing diodes and transistors called out in the parts lists with 1N and 2N standard numbers, replace them with the same manufacturing brand of diode or transistor as removed, when possible. Where the parts list indicates a specific manufacturer and part number, only that manufacturer's part and part number should be used for the replacement.

PARTS LISTS

6-4. MANUFACTURERS' NAME ABBREVIATIONS

AB	Allen Bradley
ALCO	Alco Electronic Products, Inc.
AMRA	American Radionic
AUG	Augat
BEL	Belden
BECK	Beckman
CBS	CBS Laboratories
CDE	Cornell-Dubilier Electronics
CIN	Cinch Manufacturing
ELM	Elmenco
GEN	General Electric
IND	Industrial Devices
IRC	International Resistance
LF	Little Fuse, Inc.
MAL	Mallory
MOL	Molex
SPR	Sprague
TI	Texas Instruments
VER	Vero

PARTS LISTS

6-5. MAIN ASSEMBLY (MODEL 4110 OR 4100)

<u>Ref</u>	<u>Description</u>	<u>Mfr</u>	<u>Part No.</u>	<u>Used on (X)</u>	
				<u>Model</u> 4110	<u>Model</u> 4100
	Chassis assembly	CBS	962200	X	X
	Nameplate	CBS	960315-69	X	
	Nameplate	CBS	960315-70		X
	Cord, 3 wire, 18 AWG	BEL	17237	X	X
A1, A4	High-frequency board (See paragraph 6-6.)	CBS	962193-1	X	
A1	High-frequency board (See paragraph 6-6.)	CBS	962193-2		X
A2, A5	Input-output board (See paragraph 6-7.)	CBS	962197-1	X	
A2	Input-output board (See paragraph 6-7.)	CBS	962197-2		X
A3	Power supply and AGC board (See paragraph 6-8.)	CBS	962188	X	X
A6	Front panel assembly (See paragraph 6-9.)	CBS	962203-1	X	
A6	Front panel assembly (See paragraph 6-9.)	CBS	962203-2		X
F1	Fuse, 3/10 amp	LF	3AG SLO-BLO	X	X
T1	Transformer, audio	CBS	962132	X	X
T2	Transformer, power	CBS	962229	X	X
T3	Transformer, audio	CBS	962132	X	

PARTS LISTS

6-5. MAIN ASSEMBLY (MODEL 4110 OR 4100) (cont)

<u>Ref</u>	<u>Description</u>	<u>Mfr</u>	<u>Part No.</u>	<u>Used on (X)</u>	
				<u>Model 4110</u>	<u>Model 4100</u>
TB1	Terminal, strip	CIN	54C	X	X
TB2	Terminal, block	CIN	353-18-10-001	X	X
XF1	Fuseholder	LF	342012	X	X

6-6. HIGH FREQUENCY BOARD A1 AND A4*

<u>Ref</u>	<u>Description</u>	<u>Mfr</u>	<u>Part No.</u>
<u>RESISTORS</u>			
R1, R46	75 kilohms		
R2	4.7 kilohms		
R3, R6, R10 R13, R19	7.5 kilohms		
R4	4.53 kilohms, 1/8w, 1%	IRC	CEA-TO
R5, R17, R18	9.09 kilohms, 1/8w, 1%	IRC	CEA-TO
R7	15 kilohms		
R8	Variable, 1 kilohms	BECK	62PR1K
R9	100 kilohms		
R11	5.62 kilohms, 1/8w, 1%	IRC	CEA-TO
R12	11.3 kilohms, 1/8w, 1%	IRC	CEA-TO
R14	30 kilohms		

* A4 is used on Model 4110 only.

PARTS LISTS

6-6. HIGH FREQUENCY BOARD A1 AND A4* (cont)

<u>Ref</u>	<u>Description</u>	<u>Mfr</u>	<u>Part No.</u>
<u>RESISTORS (cont)</u>			
R15, R16	620 ohms		
R20, R41	8.2 kilohms		
R21	27 kilohms		
R22, R23, R26, R30, R43, R44	1 kilohm		
R24	24 kilohms		
R25	5.1 kilohms		
R27	12 kilohms		
R28	68 kilohms		
R29, R33	10 kilohms		
R31	Variable, 5 kilohms	BECK	62PR5K
R32, R35	Variable, 20 kilohms	BECK	62PR20K
R34	5.6 ohms, 1/2w		
R36, R42	51 kilohms		
R37, R38	1.00 kilohms, 1/8w, 1%		
R39	Variable, 10 kilohms	BECK	62PR10K
R40	9.1 kilohms		
R45	33 kilohms		

* A4 is used on Model 4110 only.

PARTS LISTS

6-6. HIGH FREQUENCY BOARD A1 AND A4* (cont)

<u>Ref</u>	<u>Description</u>	<u>Mfr</u>	<u>Part No.</u>
<u>CAPACITORS</u>			
C1	1200 pf, 2%	ELM	DM-19-122G
C2, C3, C7, C8, C10	5000 pf, 2%	ELM	DM-19-502G
C4, C12, C14 C19, C20	4.7 μ f, 35v	MAL	TAC475M035P04
C5, C6	0.47 μ f, 100v	AMRA	2MBPC1474M
C9	0.12 μ f, 100v	ELM	IMDF3-124
C11	2500 pf, 2%	ELM	DM-19-252G
C13	7500 pf	ELM	DM-19-752J
C15, C21	51 pf	CDE	CD15ED510J03
C16	47 μ f, 20v	SPR	196D476X0020-LA3
C17	1 μ f, 100v	AMRA	2MBPC1105K
C18	3000 pf	ELM	DM-19-302J
C22**	68 μ f, 25v	SPR	196D686X0025MA3
C23	200 pf		CM05FD201J03

SEMICONDUCTORS

CR1, CR6, CR7, Diode CR8, CR9			1N456A
CR2, CR3, CR4, CR5	Diode, matched set ***		

* A4 is used on Model 4110 only.

** Used on Model 4110 only.

*** Vf matched to within 10 mv. If = 1.0 ma

PARTS LISTS

6-6. HIGH FREQUENCY BOARD A1 AND A4* (cont)

<u>Ref</u>	<u>Description</u>	<u>Mfr</u>	<u>Part No.</u>
<u>SEMICONDUCTORS (cont)</u>			
Q1, Q4, Q7, Q8, Q10, Q11	Transistor		2N3904
Q2, Q5, Q6, Q13	Transistor		2N5308
Q3, Q9, Q12	Transistor		2N3906
VR1, VR2	Zener diode		1N748A
VR3, VR4	Zener diode		1N968B

MISCELLANEOUS

J1, J2		MOL	A-2183-8A
J3		MOL	A-2183-4A
L1	Inductor, 50 mhy, $\pm 3\%$	CBS	990554
	Etch, drill and mark assy	CBS	962191

6-7. INPUT-OUTPUT BOARD A2 AND A5**

<u>Ref</u>	<u>Description</u>	<u>Mfr</u>	<u>Part No.</u>
<u>RESISTORS</u>			
R1, R45	1.5 kilohms		
R2, R46	5.1 kilohms		
R3, R34	2.4 kilohms		
R4, R6, R25, R26, R35	4.7 kilohms		

* A4 is used on Model 4110 only.

**A5 is used on Model 4110 only.

PARTS LISTS

6-7. INPUT-OUTPUT BOARD A2 AND A5*

<u>Ref</u>	<u>Description</u>	<u>Mfr</u>	<u>Part No.</u>
<u>RESISTORS (cont)</u>			
R5	620 ohms		
R7, R13, R14, R19, R21, R22, R24, R36, R41, R42	10 kilohms		
R8, R20	240 ohms		
R9	1.8 kilohms		
R10	Variable, 1 kilohm	BECK	62PR1K
R11, R23	24 ohms		
R12	1 kilohms		
R15, R47	3 kilohms		
R16, R40	5.6 kilohms		
R17, R48	30 kilohms		
R18	10 ohms		
R27, R38	100 kilohms		
R28, R39	75 ohms		
R29	1.2 kilohms		
R30	Variable, 2 kilohms	BECK	62PR2K
R31, R43	9.1 kilohms		
R32	15 ohms		
R33, R44	33 ohms		

* A5 is used on Model 4110 only.

PARTS LISTS

6-7. INPUT-OUTPUT BOARD A2 AND A5* (cont)

<u>Ref</u>	<u>Description</u>	<u>Mfr</u>	<u>Part No.</u>
<u>RESISTORS (cont)</u>			
R37*	20 ohms		
R49*	51 ohms		
R50*	20 ohms		
<u>CAPACITORS</u>			
C1, C4, C5, C6, C10	4.7 μ f, 35v	MAL	TAC475M035P04
C2, C7	8.2 μ f, 35v	MAL	TAC825K035P04
C3, C8, C9	Not used		
C11*, C12*	75 μ f, 25v	MAL	TT25X75A
C13, C14	2500 pf	ELM	DM-19-252G
<u>SEMICONDUCTORS</u>			
CR1, CR2**	Diode		1N456A
Q1, Q3, Q4, Q5, Q7 thru Q10, Q12 thru Q14	Transistor		2N3393
Q2, Q11	Transistor		2N3391
Q6, Q15	Transistor		D40D4
<u>MISCELLANEOUS</u>			
J1, J2	Wafer pin assy, 8 pin	MOL	A2183-8A
J3	Wafer pin assy, 10 pin	MOL	A2183-10A

* Used on Model 4110 only.

** Matched pair for Vf within 10 mv. If = 1.0 ma

PARTS LISTS

6-7. INPUT-OUTPUT BOARD A2 AND A5*(cont)

<u>Ref</u>	<u>Description</u>	<u>Mfr</u>	<u>Part No.</u>
<u>MISCELLANEOUS (cont)</u>			
J4	Wafer pin assy, 3 pin	MOL	A2183-3A
	Etch, drill, and mark assy	CBS	962196

6-8. POWER SUPPLY AND AGC BOARD A3

<u>Ref</u>	<u>Description</u>	<u>Mfr</u>	<u>Part No.</u>
<u>RESISTORS</u>			
R1	Wirewound, 3.9 ohms, 1w		
R2	Wirewound, 3.9 ohms, 1w	SPR	239E3R95
R3	470 ohms, 1/2w		
R4	68 ohms, 1/2w		
R5, R22	360 kilohms		
R6, R23, R30**	5.1 kilohms		
R7	6.8 kilohms		
R8, R15	10 kilohms		
R9, R16	82 ohms		
R10	7.5 kilohms		
R11, R18	100 kilohms		
R12	Variable, 2 kilohms	BECK	62PR2K
R13	1 kilohm, 1/2w		
R14	82 ohms, 1/2w		

* Used on Model 4110 only.

**Select at test.

PARTS LISTS

6-8. POWER SUPPLY AND AGC BOARD A3 (cont)

<u>Ref</u>	<u>Description</u>	<u>Mfr</u>	<u>Part No.</u>
------------	--------------------	------------	-----------------

RESISTORS (cont)

R17, R31	Variable, 5 kilohms	BECK	62PR5K
R19	2.4 kilohms		
R20	470 kilohms		
R21	100 ohms, 2w		
R24	Variable, 1 kilohm	BECK	62PR1K
R25	Variable, 100 ohms	BECK	62PR100
R26	4.3 kilohms		
R27	Not used		
R28	1.8 kilohms		
R29	3 kilohms		
R32*	470 ohms		
R33, R34	91 kilohms		

CAPACITORS

C1 thru C4, C7, C8	500 μ f, +100%, -10%, 50v	MAL	TCW501N050L1F3P
C5, C6, C10, C11	4.7 μ f, \pm 20%, 35v	MAL	TAC475M035-P04
C9	0.47 μ f, \pm 10%, 100v	AMRA	2MBPC1474K

SEMICONDUCTORS

CR1	Bridge rectifier	VER	VE18
CR2, CR3	Diode		1N456A

* Optional

PARTS LISTS

6-8. POWER SUPPLY AND AGC BOARD A3 (cont)

<u>Ref</u>	<u>Description</u>	<u>Mfr</u>	<u>Part No.</u>
<u>SEMICONDUCTORS (cont)</u>			
CR4*	Diode		1N3121
Q1	Transistor		2N3766
Q2, Q4	Transistor		2N3393
Q3	Transistor	GEN	D41D1
Q5	Transistor, field effect	TI	TI558 (Yel)
VR1	Diode, zener, 20v		1N4747A
VR2	Diode, zener, 15v		1N4744A
<u>MISCELLANEOUS</u>			
J1	Wafer pin assy, 4 pin	MOL	A2183-4A
J2	Wafer pin assy, 8 pin	MOL	A2183-8A
J3	Wafer pin assy, 10 pin	MOL	A2183-10A
XQ5	Socket, transistor	AUG	8060-1G7
	Etch, drill, and mark assy	CBS	962187

* Optional

PARTS LISTS

6-9. FRONT PANEL ASSEMBLY A6 (MODEL 4110 OR 4100)

<u>Ref</u>	<u>Description</u>	<u>Mfr</u>	<u>Part No.</u>	<u>Used on (X)</u>	
				<u>Model 4110</u>	<u>Model 4100</u>
	Nameplate	CBS	962199-4	X	
	Nameplate	CBS	962199-5		X
DS1	Lamp, pilot (red)	IND	2150-A1	X	X
M1	Meter	CBS	962212	X	X
R1	Variable, 5 kilohms	AB	WA4N020S- 502AA	X	X
R2	Variable, 600 ohms, T pad	AB	GD4N020S- 601NE	X	X
R3, R4	Variable, 620 ohms			X	X
R5	Not used				
R6	Variable, 5 kilohms	AB	WA4N020S- 502AA	X	
R7	Variable, 600 ohms, T pad	AB	GD4N020S- 601NE	X	
R8, R9	Variable, 620 ohms			X	
S1	SPDT	ALCO	MST-105D	X	X
S2	4PDT	ALCO	MST-405N	X	
S2	DPDT	ALCO	MST-205N		X

SECTION VII

DRAWINGS

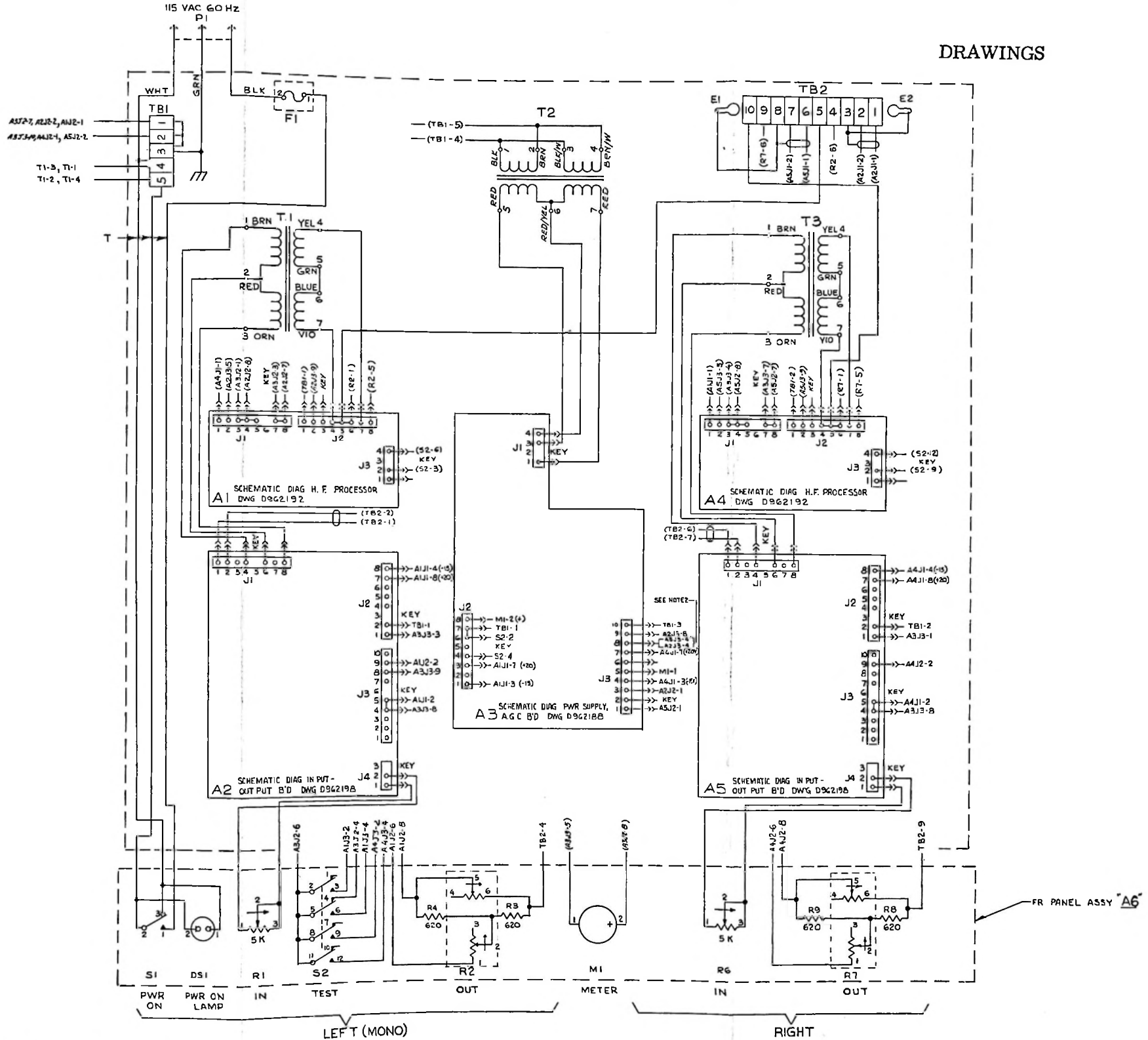

- NOTES:
1. R6 THRU R9, A4, A5, T3, E1, TERMINALS TB2-4 THRU 10 ARE USED ON MODEL 4110 (STEREO) ONLY.
 2. MONO UNITS (4100) CONNECT PIN 8 OF A3J3 TO A2J3-4 ONLY. STEREO UNITS (4110) CONNECT PIN 8 OF A3J3 TO A5J3-4 ONLY.

Figure 7-1. FM Volumax, Internal Interconnections

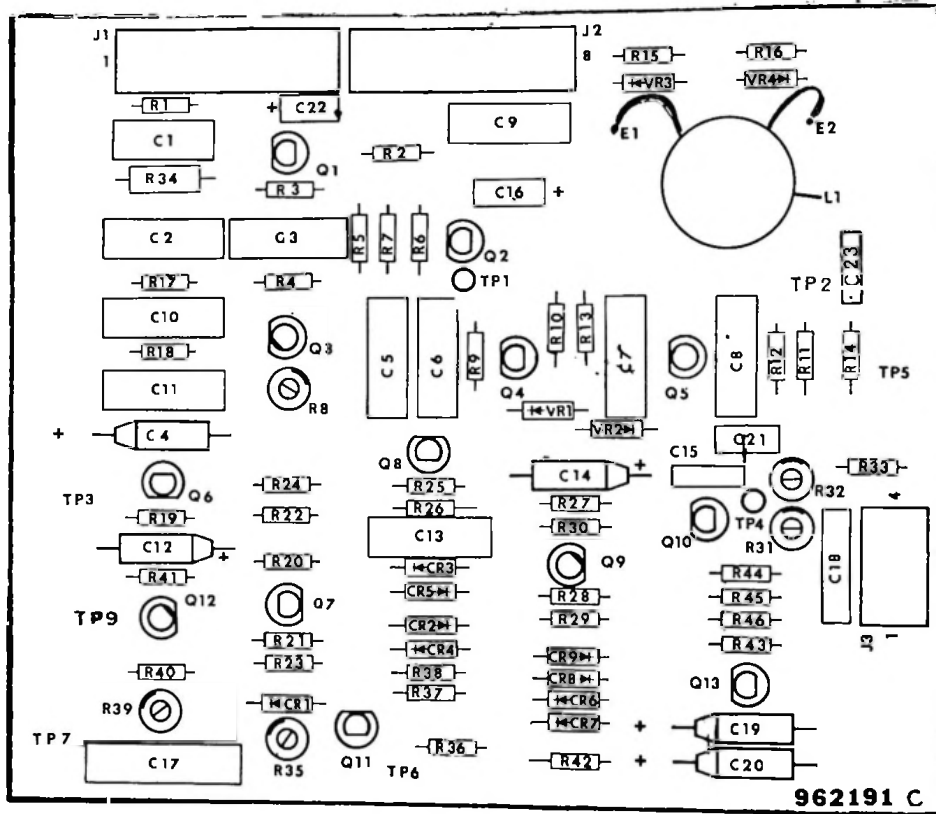

NOTES:

1. REMOVE (CUT) FROM CONNECTORS J1, J2 & J3 RESPECTIVELY PIN N° 6, 3, & 3 FOR POLARIZATION.

DRAWINGS

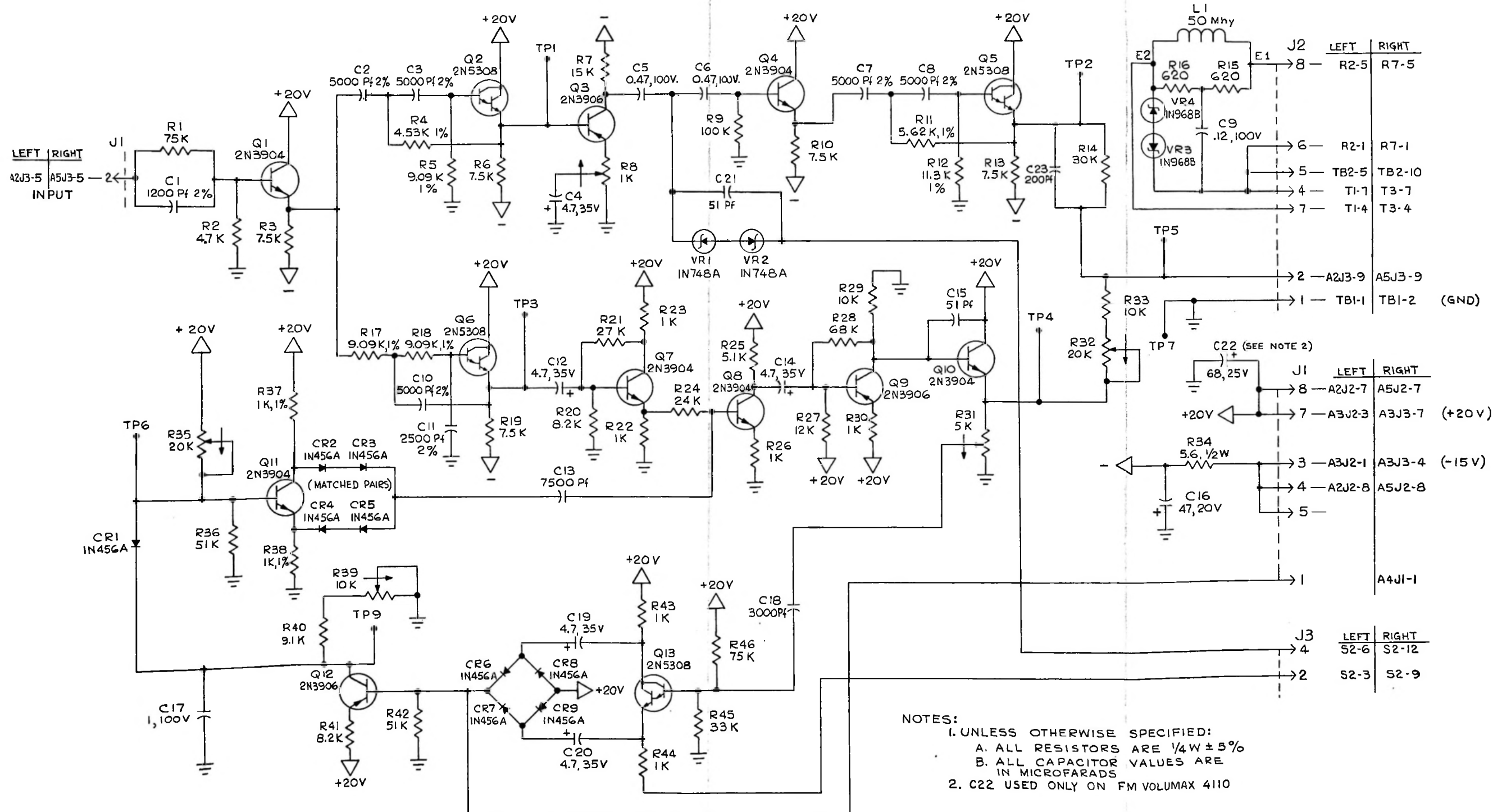

NOTES:
 1. UNLESS OTHERWISE SPECIFIED:
 A. ALL RESISTORS ARE 1/4W ± 5%
 B. ALL CAPACITOR VALUES ARE IN MICROFARADS
 2. C22 USED ONLY ON FM VOLUMAX 4110

Figure 7-2. High Frequency Processor Board A1 or A4, Schematic and Parts Location Diagrams

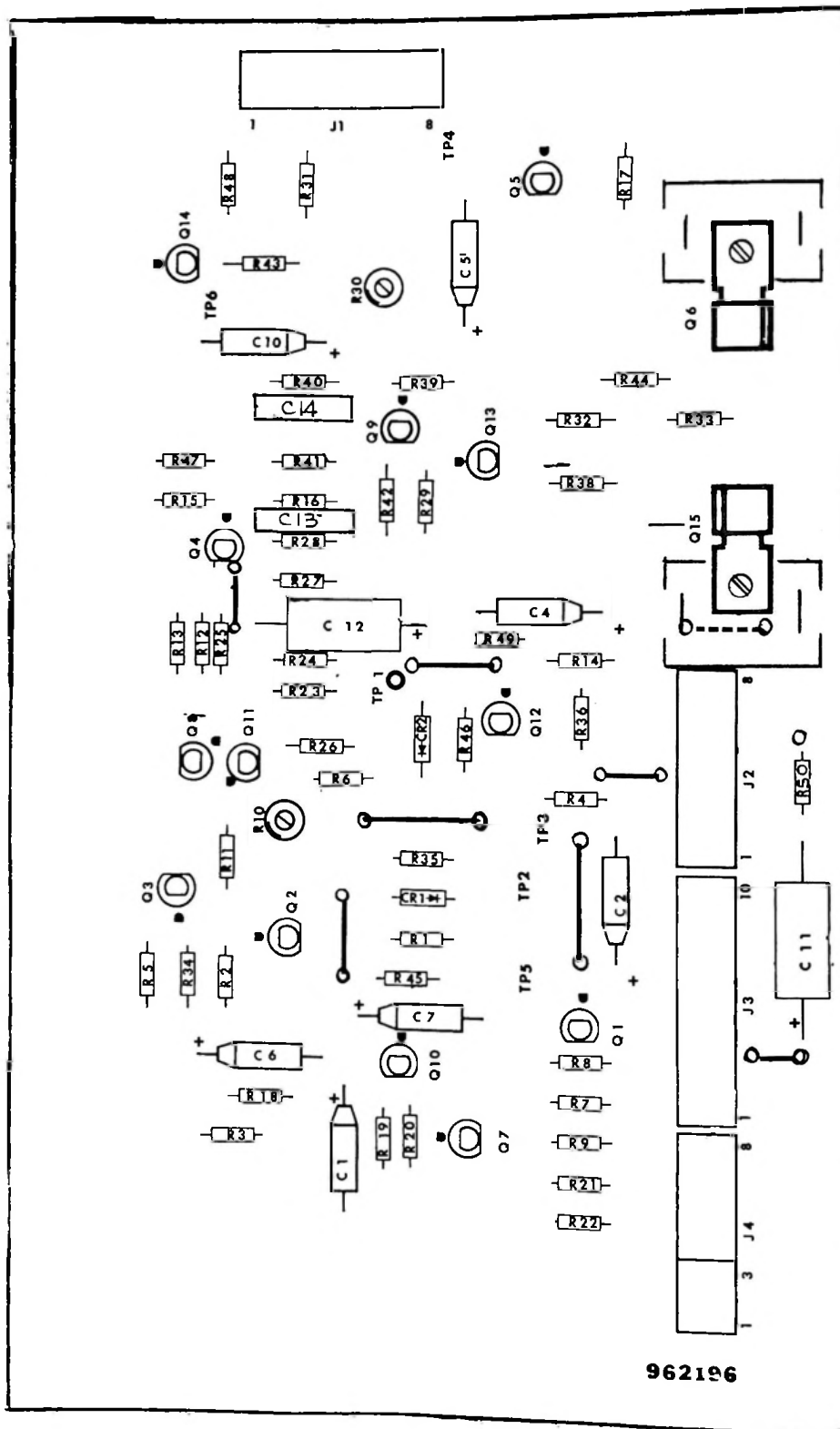

NOTES :

1. REMOVE (CUT) FROM CONNECTORS J1, J2, J3 & J4 RESPECTIVELY PIN N^oS 5, 3, 6, & 3 FOR POLARIZATION.

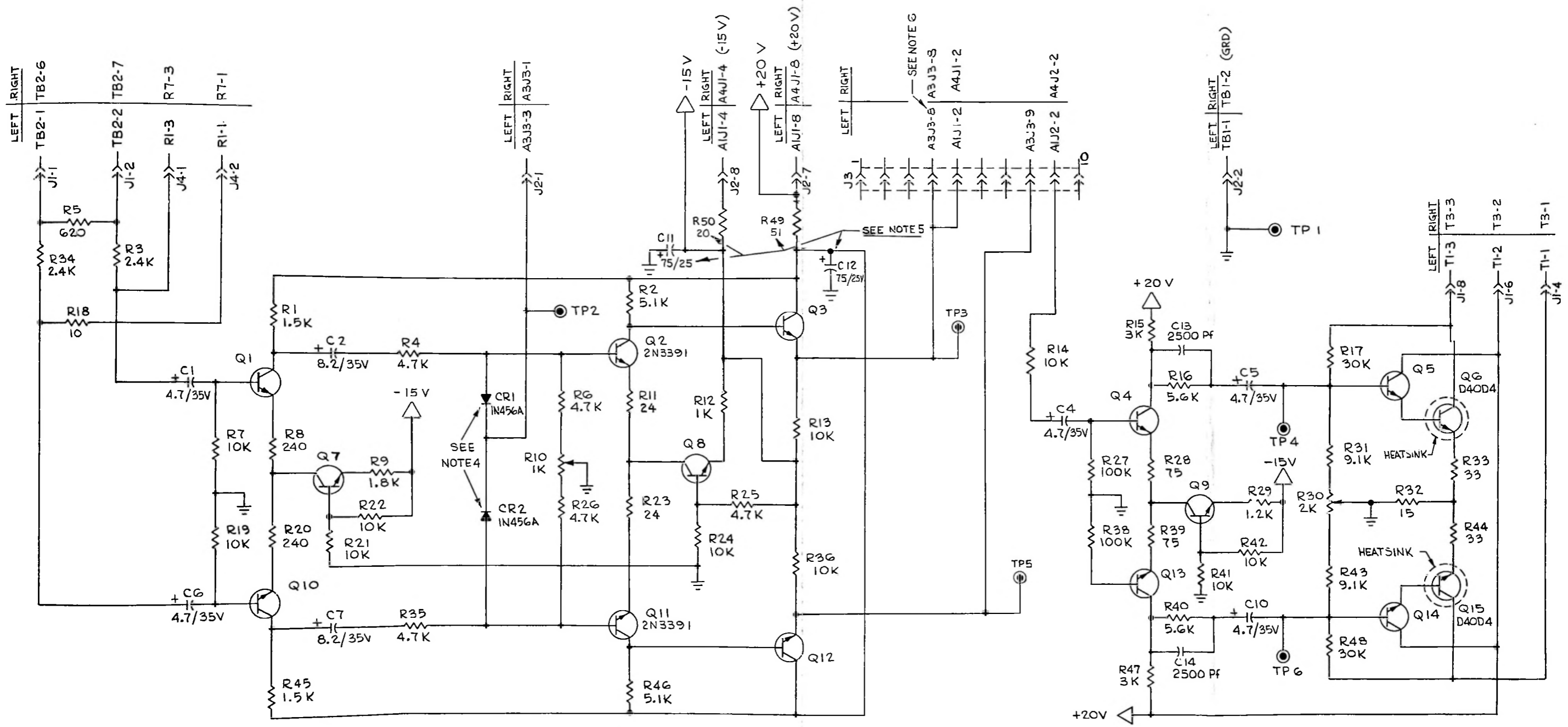

- NOTES:**
 (UNLESS OTHERWISE SPECIFIED)
1. ALL RESISTOR VALUES ARE IN OHMS, POWER RATING 1/4 W, 5%
 2. ALL CAPACITOR VALUES IN MICROFARADS
 3. ALL TRANSISTORS ARE 2N3393
 4. CR1 & CR2 ARE MATCHED DIODES
 5. R50 AND R49 ARE REPLACED WITH BUS JUMPERS AND C11 AND C12 ARE NOT USED ON FM VOLUMAX 4100.
 6. USE FOR MODEL 4100 ONLY.

Figure 7-3. Input-Output Board A2 or A5, Schematic and Parts Location Diagrams

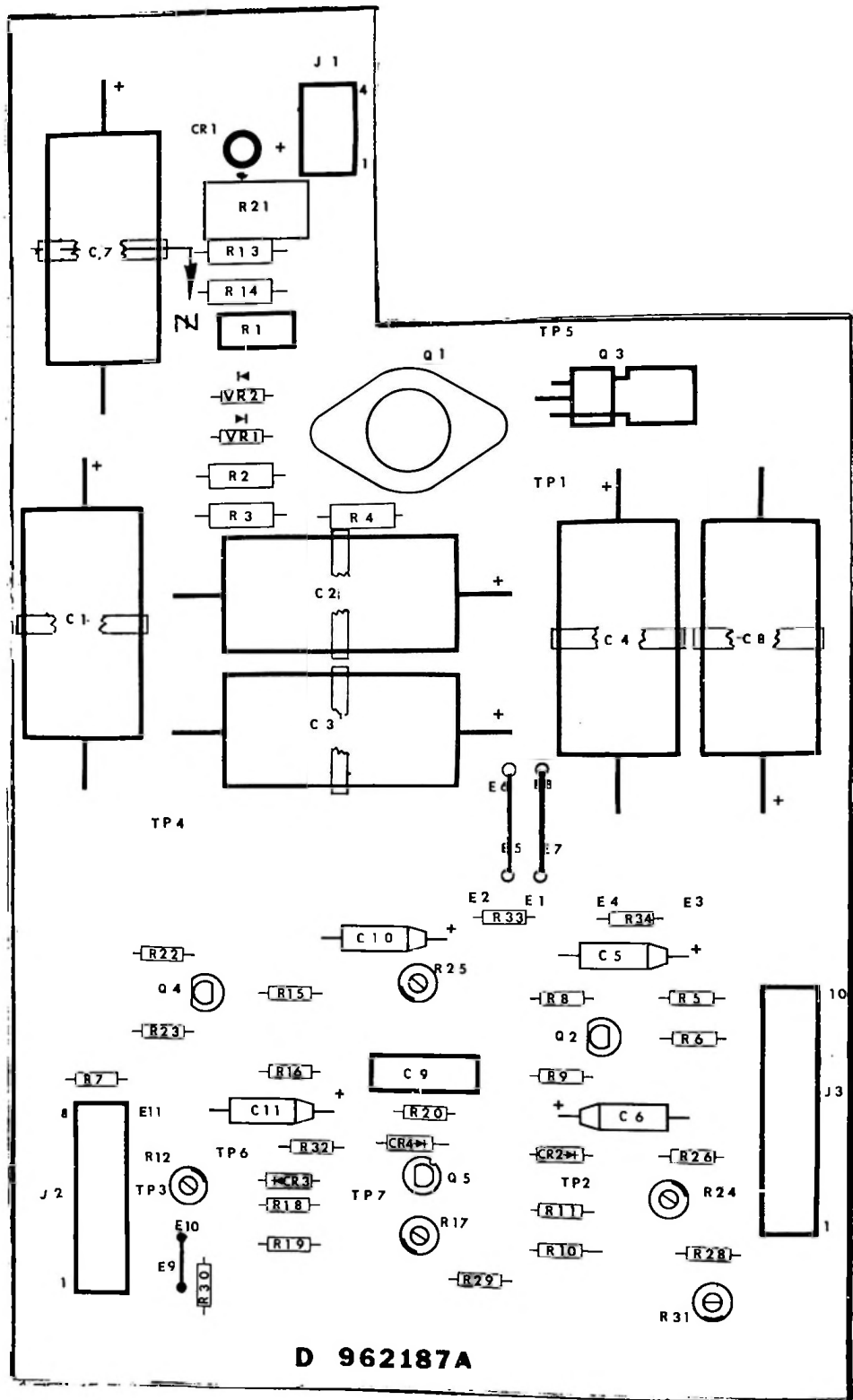

NOTES:

1. REMOVE (CUT) FROM CONNECTORS J1, J2, & J3 RESPECTIVELY PIN N° 2, 5 & 2 FOR POLARIZATION.
2. TERMINATE BUS WIRE JUMPERS BETWEEN "E5", "E6", & "E7", "E8" AS SHOWN

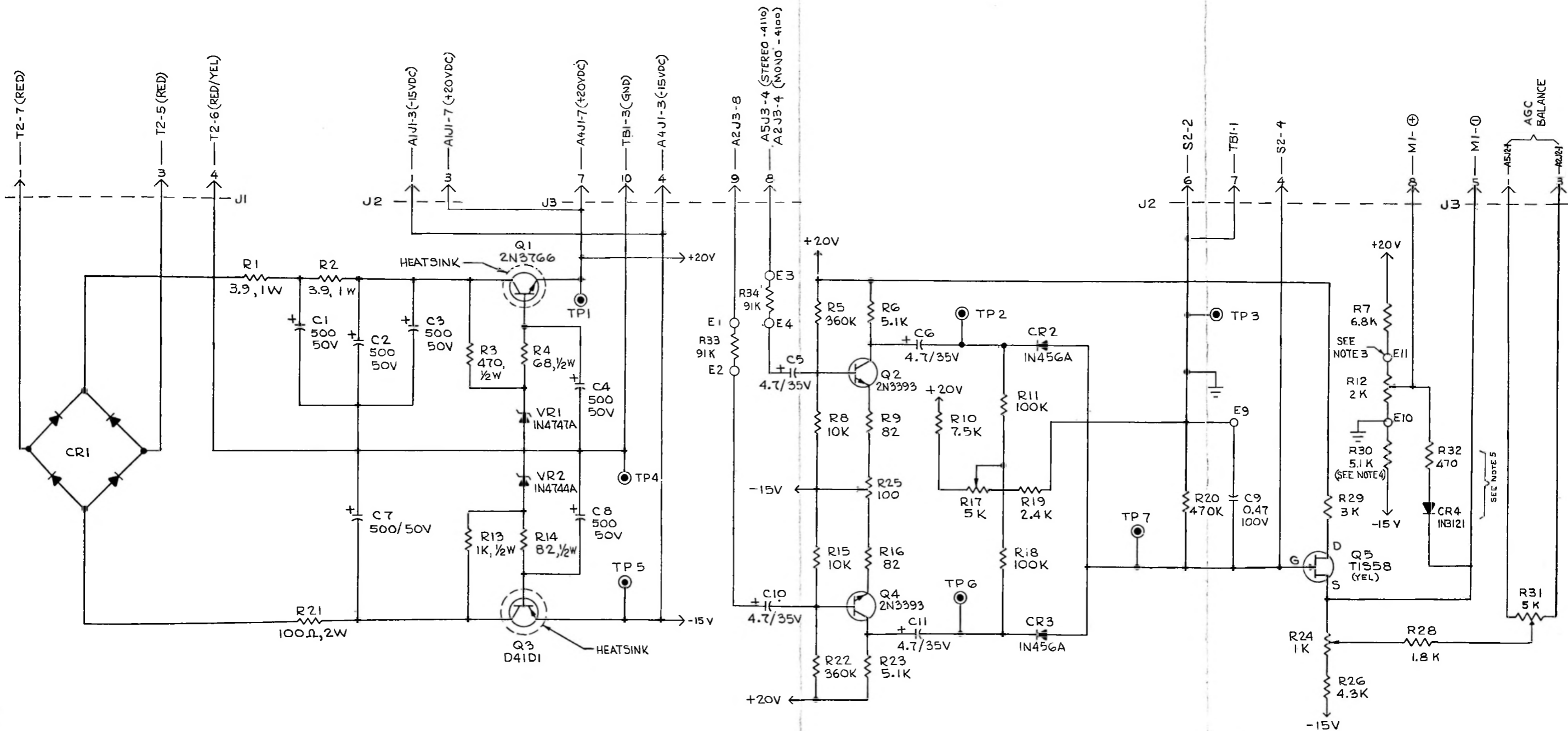

- NOTES:**
 (UNLESS OTHERWISE SPECIFIED)
1. ALL RESISTOR VALUES ARE IN OHMS, POWER RATING 1/4W, 5%
 2. ALL CAPACITOR VALUES IN MICROFARADS
 3. E10 OR E11 MAY BE GROUNDLED.
 4. SELECT AT TEST.
 5. R32 & CR4 ARE OPTIONAL, ONLY USED FOR METER COMPRESSION.

Figure 7-4. Power Supply-AGC Board A3, Schematic and Parts Location Diagrams