

Collins

Collins

INSTRUCTION BOOK

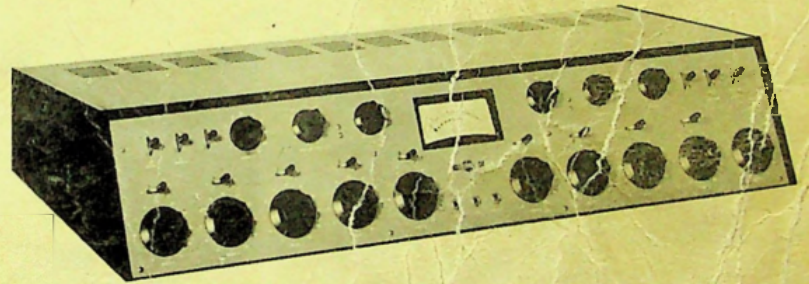
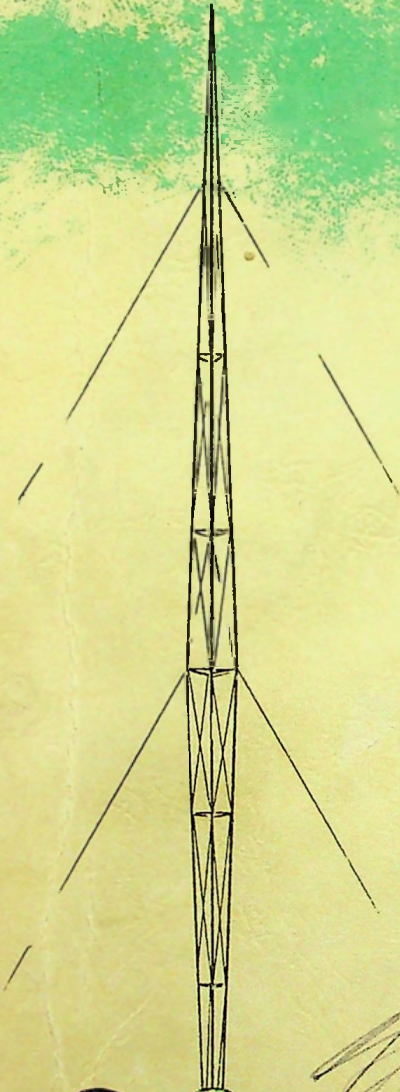

BROADCAST CONSOLE

212G-1

Production

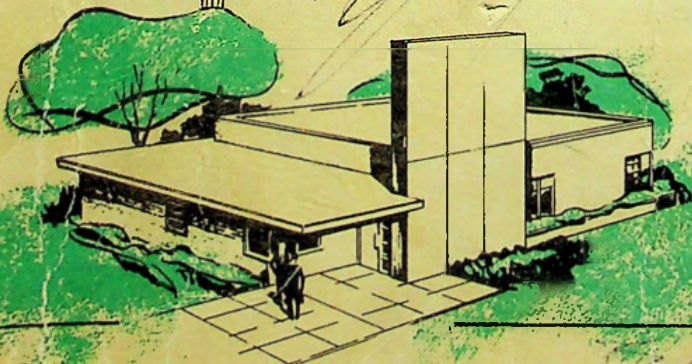

COLLINS RADIO COMPANY

GUARANTEE

The equipment described herein is sold under the following guarantee:

Collins agrees to repair or replace, without charge, any equipment, parts, or accessories which are defective as to design, workmanship or material, and which are returned to Collins at its factory, transportation prepaid, provided

- (a) Notice of the claimed defect is given Collins within one (1) year from date of delivery and goods are returned in accordance with Collins' instructions.
- (b) Equipment, accessories, tubes, and batteries not manufactured by Collins or from Collins' designs are subject to only such adjustments as Collins may obtain from the supplier thereof.
- (c) No equipment or accessory shall be deemed to be defective if, due to exposure or excessive moisture in the atmosphere or otherwise after delivery, it shall fail to operate in a normal or proper manner.

Collins further guarantees that any radio transmitter described herein will deliver full radio frequency power output at the antenna lead when connected to a suitable load, but such guarantee shall not be construed as a guarantee of any definite coverage or range of said apparatus.

The guarantee of these paragraphs is void if equipment is altered or repaired by others than Collins or its authorized service center.

No other warranties, expressed or implied, shall be applicable to any equipment sold hereunder, and the foregoing shall constitute the Buyer's sole right and remedy under the agreements in this paragraph contained. In no event shall Collins have any liability for consequential damages, or for loss, damage or expense directly or indirectly arising from the use of the products, or any inability to use them either separately or in combination with other equipment or materials, or from any other cause.

HOW TO RETURN MATERIAL OR EQUIPMENT. If, for any reason, you should wish to return material or equipment, whether under the guarantee or otherwise, you should notify us, giving full particulars including the details listed below, insofar as applicable. If the item is thought to be defective, such notice must give full information as to nature of defect and identification (including part number if possible) of part considered defective. (With respect to tubes we suggest that your adjustments can be speeded up if you give notice of defect directly to the tube manufacturer.) Upon receipt of such notice, Collins will promptly advise you respecting the return. Failure to secure our advice prior to the forwarding of the goods or failure to provide full particulars may cause unnecessary delay in handling of your returned merchandise.

ADDRESS:

Collins Radio Company
Sales Service Department
Cedar Rapids, Iowa

INFORMATION NEEDED:

- (A) Type number, name, and serial number of equipment
- (B) Date of delivery of equipment
- (C) Date placed in service
- (D) Number of hours of service
- (E) Nature of trouble
- (F) Cause of trouble if known
- (G) Part number (9 or 10 digit number) and name of part thought to be causing trouble
- (H) Item or symbol number of same obtained from parts list or schematic
- (I) Collins' number (and name) of unit sub-assemblies involved in trouble
- (J) Remarks

HOW TO ORDER REPLACEMENT PARTS.

When ordering replacement parts, you should direct your order as indicated below and furnish the following information insofar as applicable. To enable us to give you better replacement service, please be sure to give us complete information.

ADDRESS:

Collins Radio Company
Sales Service Department
Cedar Rapids, Iowa

INFORMATION NEEDED:

- (A) Quantity required
- (B) Collins' part number (9 or 10 digit number) and description
- (C) Item or symbol number obtained from parts list or schematic
- (D) Collins' type number, name, and serial number of principal equipment
- (E) Unit sub-assembly number (where applicable)

SYSTEM INSTRUCTION BOOK

BROADCAST CONSOLE

212G-1

CONTENTS

SP-144	Broadcast Console 212E-1
TD-323	Preamplifier 356A-1
TD-324	Program/Monitor Amplifier 356B-1
TD-325	Limiter Amplifier 356E-1
TD-326	Cue Amplifier 356Q-1
TD-327	Relay Unit 274K-2
TD-328	Power Supply 409X-2

523 0033 00
15 JANUARY 1960



© COLLINS RADIO COMPANY
1960

Cedar Rapids, Iowa, U.S.A.

BROADCAST CONSOLE

212G-1

© **COLLINS RADIO COMPANY**
1960

CEDAR RAPIDS, IOWA, U.S.A.

PRINTED IN THE UNITED STATES OF AMERICA



TABLE OF CONTENTS

Section		Page
I	GENERAL DESCRIPTION	5
1.1	Purpose of Instruction Book	5
1.2	Purpose of Equipment	5
1.3	Basic Equipment	5
1.4	Applicable Subassembly Instruction Books	6
1.5	Description of Major Components.	6
1.5.1	Broadcast Console 212G-1	6
1.5.2	Preamplifier 356A-1	6
1.5.3	Program/Monitor Amplifier 356B-1.	6
1.5.4	Limiter Amplifier 356E-1	6
1.5.5	Cue Amplifier 356Q-1	6
1.5.6	Relay Unit 274K-2	6
1.5.7	Power Supply 409X-2	6
1.5.8	Rack Mounting Shelf 499G-1	6
1.5.9	Jumper Plug	6
1.5.10	Amplifier Test Cable	7
1.6	Electrical Characteristics	7
1.7	Physical Specifications	8
II	INSTALLATION AND ADJUSTMENT	8
2.1	Unpacking and Inspecting	8
2.2	Installation Procedure	8
2.2.1	General	8
2.2.2	Equipment Location	8
2.2.3	Equipment Mounting Procedure	8
2.2.4	Installation Wiring	10

Section	Page	
2.3	Modification and Initial Adjustments	11
2.3.1	General	11
2.3.2	Selection of Impedances	11
2.3.3	Gain Adjustment for Program/Monitor Amplifier 356B-1	11
2.3.4	Adjustment of 300 Volts D-C Output from Power Supply 409X-2	11
2.3.5	Initial Adjustments for Use of Limiter Amplifier 356E-1	11
2.3.6	Monitoring External Circuit Level with VU Meter	12
2.3.7	Resistor Values for Fixed Pads	12
2.3.8	Suggested Function for Spare Switches	13
2.3.9	Speaker and Warning Light Control Circuits.	13
III	OPERATION	14
3.1	Control Functions	14
3.1.1	Mixer	14
3.1.2	Mixer Selector Switches.	14
3.1.3	Program/Audition Selector Switches	14
3.1.4	Gain Controls	14
3.1.5	Mixer 9 Net/Remote Switch	14
3.1.6	Remote Function Selector Switches.	14
3.1.7	Monitor Input Switch	15
3.1.8	Meter Input Switch	15
3.1.9	Program Switch	15
3.1.10	Spare Switches	15
3.2	Operating Procedures	15
3.2.1	Routine Operation	15
3.2.1.1	Local Program on the Air.	15
3.2.1.2	Audition Program	15
3.2.2	Remote Line Operation	15
3.2.2.1	Remote Program on the Air	15
3.2.2.2	Feed Cue Signal and Switch Remote Line to on the Air	15
3.2.2.3	Record Operation	15
3.2.2.4	Talk-Back Operation Using Speakers	16
3.2.2.5	Talk-Back Operation Using Headphones.	16
IV	PRINCIPLES OF OPERATION	16
4.1	General	16
4.2	Mixer Circuits.	16
4.3	Program Circuits	16
4.4	Monitor Circuits	21
4.5	Studio Speaker and Warning Light Control Circuits.	21
V	MAINTENANCE	24
5.1	Periodic Inspection and Preventive Maintenance	24
5.1.1	Attenuators	24
5.1.2	Key Switches.	24
5.1.3	Wiring	24
5.2	Trouble Shooting	24
5.2.1	General	24
5.2.2	Replacement of Meter Lamps	24
5.2.3	Excessive Distortion	24
VI	PARTS LIST	25
VII	ILLUSTRATIONS	29

LIST OF ILLUSTRATIONS

Figure		Page
1-1	Broadcast Console 212G-1 (C583-12-P)	4
2-1	Broadcast Console 212G-1, Mounting and Wiring Detail (C583-20-P)	9
2-2	Broadcast Console 212G-1, Amplifier Connector Location (C583-02-3)	9
2-3	Jumper Plug Wiring Schematic Diagram (C187-02-2)	11
2-4	Resistor Values for Fixed Pads (C583-24-3)	13
3-1	Broadcast Console 212G-1, Control Locations (C583-16-P)	14
4-1	Broadcast Console 212G-1, Functional Block Diagram (C583-01-4)	17/18
4-2	Mixer Circuits, Simplified Schematic Diagram (C583-09-5)	19/20
4-3	Program Circuits, Simplified Schematic Diagram (C583-04-4)	21
4-4	Monitor Circuits, Simplified Schematic Diagram (C583-08-4)	22
4-5	Speaker and Warning Light Control Circuits, Simplified Schematic Diagram (C583-07-4)	23
6-1	Broadcast Console 212G-1, Front Panel, Rear View (C583-21-P)	25
6-2	Broadcast Console 212G-1, Inside View (C583-23-P)	25
6-3	Jumper Plug (C187-27-P)	27
6-4	Test Cable (C187-26-P)	27
7-1	Broadcast Console 212G-1, Schematic Diagram (C583-10-6)	29
7-2	Broadcast Console 212G-1, Switch Pin Orientation (C583-11-5)	30
7-3	Broadcast Console 212G-1, Outline and Mounting Dimensions (C583-15-5)	31/32

LIST OF TABLES

Table		Page
1-1	Broadcast Console 212G-1, Equipment Available	5
1-2	Subassembly Instruction Books	6
1-3	Broadcast Console 212G-1 Electrical Characteristics	7
1-4	Broadcast Console 212G-1 Physical Specifications	8
2-1	Connections to Terminal Strip TB1	10
2-2	Line Levels	12
2-3	Line Levels	12

UNIT INSTRUCTIONS

TD No.	Title
323	Preamplifier 356A-1
324	Program/Monitor Amplifier 356B-1
325	Limiter Amplifier 356E-1
326	Cue Amplifier 356Q-1
327	Relay Unit 274K-2
328	Power Supply 409X-2

SP-144
Broadcast Console 212G-1



Figure 1-1. Broadcast Console 212G-1

SECTION I GENERAL DESCRIPTION

1.1 PURPOSE OF INSTRUCTION BOOK.

This instruction book is intended to serve as a guide in the installation, adjustment, operation, and maintenance of Broadcast Console 212G-1.

1.2 PURPOSE OF EQUIPMENT.

Broadcast Console 212G-1 is designed especially for use in high-fidelity AM, FM, or TV broadcast installations. The number and arrangement of amplifiers may be selected to fit individual requirements. Simultaneous mixing facilities for auditioning or

broadcasting of up to 9 of 13 possible inputs are provided. East of operation is assured by clearly identified control knobs. The number of functions available and performance are determined by the selection of preamplifiers and program/monitor amplifiers to be installed in the console.

1.3 BASIC EQUIPMENT.

The 212G-1 is illustrated in figure 1-1. The equipment available is listed in table 1-1. The type and quantity of subassemblies supplied will depend on individual station requirements.

TABLE 1-1. BROADCAST CONSOLE 212G-1, EQUIPMENT AVAILABLE

ITEM	OVER-ALL DIMENSIONS (inches)			WEIGHT (lb)	COLLINS PART NUMBER
	H	W	D		
Broadcast Console 212G-1	8-3/16 max	41-1/16	21-1/8	75	522 1605 00
Preamplifier 356A-1	4-5/8	2-1/8	9-1/2	7-1/2	522 0389 005
Program/Monitor Amplifier 356B-1	5-3/4	2-7/8	9-1/2	9	522 0390 005
Limiter Amplifier 356E-1	5-5/16	3	9-1/2	4-3/4	522 0394 004
Cue Amplifier 356Q-1	4-5/8	2-1/8	9-1/2	2-1/4	522 1607 00
Relay Unit 409X-2	5-1/2	2-1/2	9-1/2	2-1/2	522 1691 00
Power Supply 509X-2	6	8	9	25	522 1691 00
Rack Mounting Shelf 499G-1	8-23/32	19	14	11	522 0774 00
*Jumper Plug				1/2	541 6459 002
*Amplifier Test Cable	35 length			1	541 6473 003

*Supplied as part of Broadcast Console 212G-1.

1.4 APPLICABLE SUBASSEMBLY INSTRUCTION BOOKS.

Applicable subassembly instruction books are listed in table 1-2 and supplied following section VII of this instruction book.

TABLE 1-2
SUBASSEMBLY INSTRUCTION BOOKS

PUBLICATION	COLLINS PART NUMBER
Preamplifier 356A-1	520 5446 00
Program/Monitor Amplifier 356B-1	520 5447 00
Limiting Amplifier 356E-1	520 5448 00
Cue Amplifier 356Q-1	523 0034 00
Relay Unit 274K-2	523 0036 00
Power Supply 409X-2	523 0035 00

1.5 DESCRIPTION OF MAJOR COMPONENTS.

1.5.1 BROADCAST CONSOLE 212G-1.

The 212G-1 utilizes modular type construction to provide a choice of plug-in amplifier units which will meet individual installation requirements. The front panel and top are hinged to allow easy access to all parts. The 212G-1 may be serviced from the front allowing the cabinet to be almost flush against a wall or window. There should be about 1/2-inch clearance behind the console to allow ventilation and to provide clearance for the top when open. Slots in the bottom, back, and top provide cooling by convection. Space is provided for up to eight Preamplifiers 356A-1, two Program/Monitor Amplifiers 356B-1, or one 356B-1 and one Limiting Amplifier 356E-1, one Cue Amplifier 356Q-1, one Relay Unit 274K-2, and one Power Supply 409X-2.

1.5.2 PREAMPLIFIER 356A-1.

The necessary circuitry for two stages of amplification makes up this plug-in module. It provides 40 db of gain from low-level microphone or transcription lines to feed program, audition, or cue circuits. Refer to paragraph 1.4.

1.5.3 PROGRAM/MONITOR AMPLIFIER 356B-1.

The 356B-1 has an over-all gain of 56 or 68 db for use on program lines or speaker operation. The desired level is selected by means of a toggle switch

located on the amplifier chassis. The output impedance is factory wired for 600 ohms. It may easily be changed for 150-ohm output impedance. Refer to paragraph 1.4.

1.5.4 LIMITER AMPLIFIER 356E-1.

The necessary circuitry for two stages of amplification and a bias rectifier makes up this plug-in module. It has an over-all gain of 54 db. The compression ratio is adjustable from a ratio of 1.6:1 to a ratio of 5:1. A choice of either 11 milliseconds attack time and 0.9 second release time or 62 milliseconds attack time and 5.2 seconds release time for 63 percent recovery is provided. Refer to paragraph 1.4.

1.5.5 CUE AMPLIFIER 356Q-1.

The necessary circuitry for two stages of amplification makes up this plug-in module. It provides up to 55 db gain from the cue line. The 212G-1 console provides a gain control for the 356Q-1 and a speaker for the output. The output impedance is factory wired for four ohms. Refer to paragraph 1.4.

1.5.6 RELAY UNIT 274K-2.

The 274K-2 is a plug-in module which controls application of audio power to studio speakers and a-c power to studio warning lights. The four 12-volt d-c relays are mounted on rubber to minimize noise. Transient suppressing networks across the relay coils minimize arcing and radio interference. Refer to paragraph 1.4.

1.5.7 POWER SUPPLY 409X-2.

The 409X-2 furnishes power for filaments, plate circuits, and relays in the Broadcast Console 212G-1. Silicon rectifiers are used in the high voltage circuit to eliminate the heat associated with vacuum-tube rectifiers and to ensure long life. The output of the 409X-2 is as follows: 250 to 300 volts d-c (adjustable) at 250 ma, 6.3 volts a-c at 6 amperes, and 12 volts d-c at 1 ampere. Refer to paragraph 1.4.

1.5.8 RACK MOUNTING SHELF 499G-1.

The 499G-1 consists of a panel and chassis assembly for use in an RMA standard relay rack. The front panel is a hinged door that opens downward. Base perforations provide mounting holes to accommodate any arrangement of small modules without drilling. A variety of associated connectors, mounting brackets, and cables can be supplied.

1.5.9 JUMPER PLUG.

When mixing facilities are desired for a program source that has a self-contained preamplifier, it is necessary to insert a jumper plug into the jack normally used for a Preamplifier 356A-1. The jumper plug wiring schematic diagram is shown in figure 2-3. One jumper plug is supplied with Broadcast Console 212G-1.

1.5.10 AMPLIFIER TEST CABLE.

An amplifier test cable is supplied with Broadcast Console 212G-1. This cable is 35 inches long and has a twelve-pin plug on one end and a twelve-pin jack on the other. The amplifier test cable permits operation of amplifier while it is out of the console.

1.6 ELECTRICAL CHARACTERISTICS.

Electrical characteristics of the Broadcast Console 212G-1 are listed in table 1-3. These characteristics are measured with d-c voltage adjusted to 300 volts.

TABLE 1-3. BROADCAST CONSOLE 212G-1 ELECTRICAL CHARACTERISTICS

CHARACTERISTICS	DESCRIPTION
Maximum Number of Channels	<p>6 low-level inputs, 2 medium level inputs, 1 remote or net input, 1 program channel, 1 monitor channel, and one cue channel when provided with:</p> <ul style="list-style-type: none"> 8 -- Preamplifiers 356A-1 1 -- Amplifier 356B-1 or 356E-1 1 -- Program/Monitor Amplifier 356B-1 1 -- Relay Unit 274K-2 1 -- Cue Amplifier 356Q-1 1 -- Power Supply 409X-2
Input Impedance	<p>Low Level: 20/150/250/600 ohms balanced or unbalanced*</p> <p>Net/Remote Lines: 50/150/250/600 ohms*</p> <p>Medium Level: 600 ohms (unbalanced)</p>
Output Impedance	<p>Line: 150/600 ohms*</p> <p>Monitor: 600 ohms</p>
Gain	<p>Low level to program line at least 100 db.</p> <p>Remote line to program line at least 53 db.</p> <p>Medium level to program line at least 62 db.</p>
Output Level	<p>Program Line: ±18 dbm (50 mw)</p>
Response	<p>±1.5 db, 50-15,000 cps at program line.</p>
Distortion	<p>Less than 1% at ±18 dbm at program line, less than 3% at +39 dbm at monitor amplifier output.</p>
Noise	<p>At least 68 db below +18 dbm program output with -50 dbm low level input. (Equivalent input noise level -118 dbm or less.)</p>
Power Source	<p>115 or 230 volts a-c ±10%, 50/60 cps, single phase.</p>

*Shipped wired for 600 ohms output and net/remote line impedance, 150 ohms low-level impedance, and 115-volt power source.

1.7 PHYSICAL SPECIFICATIONS.

Physical specifications of Broadcast Console 212G-1 are listed in table 1-4.

TABLE 1-4. BROADCAST CONSOLE 212G-1 PHYSICAL SPECIFICATIONS

SPECIFICATION	DESCRIPTION
Size (inches)	21-1/8 deep at base, 41-1/16 wide, 8-3/16 high at front, 6-1/2 high at back
Weight	75 pounds (basic cabinet less modules)
Finish	Metalized blue-gray enamel front panel with white silk-screened letters. Cabinet black baked enamel.

SECTION II INSTALLATION AND ADJUSTMENT

2.1 UNPACKING AND INSPECTING.

Remove all packing material, and carefully lift the units from their crates. Check the equipment against the packing slips. Visually inspect the units for any apparent damage and for missing components. Check for proper operation of controls. Any claims for damage should be filed promptly with the transportation agency. If such claims are to be filed, all packing material must be retained.

2.2 INSTALLATION PROCEDURE.**2.2.1 GENERAL.**

The location in an individual station will be determined by the arrangement of studio and control room facilities. The placement of equipment and wiring should be planned carefully before any installation work is started. Low-level microphone leads must be separated from high-level audio leads. All audio leads should be separated from the power and control wiring.

2.2.2 EQUIPMENT LOCATION.

Broadcast Console 212G-1 may be placed within 1/2-inch of a window, wall, or other vertical surface without sacrificing maintenance accessibility. Outline and mounting dimensions of the console are shown in figure 7-3.

2.2.3 EQUIPMENT MOUNTING PROCEDURE.

Lift the top panel and swing the front panel forward. Remove the three wing nuts that secure the terminal strip cover and remove the cover. Refer to figures 2-1 and 7-3. Four 1-1/2-inch diameter holes are

provided in the console base plate for the entry of external wiring. These holes are located directly in front of the terminal strip, TB1.

a. Drill additional holes for bolting down the console if desired. If the console is bolted down, the rubber feet should be left in place for spacers.

b. Rewire Preamplifiers 356A-1 to be used as booster amplifiers for 250-ohms input impedance as shown in the 356A-1 instruction book.

c. After Broadcast Console 212G-1 is mounted, the modules may be plugged into their receptacles according to the following steps. Refer to figure 2-2 for layout of unit connectors.

NOTE

To remove an amplifier module, lift its rear edge clear of the retaining rail, and push toward the rear to unplug.

d. Plug Preamplifiers 356A-1 or jumper plugs into J1 through J6 as determined by the number and types of inputs to be used. If a mixer is used with a source which does not require a preamplifier (tape recorder, turntable with external preamplifier) use a jumper plug in lieu of a 356A-1. Refer to figure 2-3 for the schematic diagram of a jumper plug. The input impedance should be 600 ohms (unbalanced). If an attenuation pad is needed, refer to figure 2-4 for correct values of resistance.

e. Plug booster amplifiers (356A-1 modules wired for 250-ohm input impedance) into J6 and J10.

f. Plug a Program/Monitor Amplifier 356B-1 into J8. Set S301 at LOW.

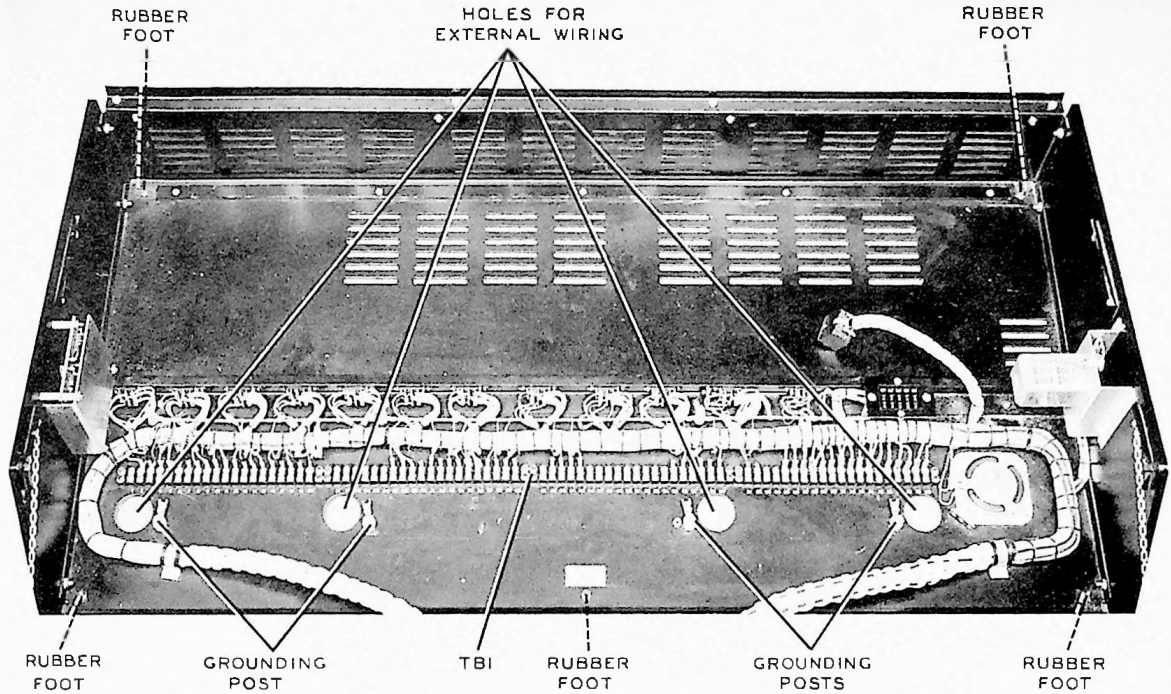

Figure 2-1. Broadcast Console 212G-1, Mounting and Wiring Detail

- g. Plug a Cue Amplifier 356Q-1 into J9, if cue speaker LS1 in the console is to be used. If a headset or an external cueing amplifier is to be used, insert a jumper plug into J9 and disconnect cue speaker LS1.
- h. Plug a Program/Monitor Amplifier 356B-1 into J11. Set S301 at HIGH.
- i. Plug Relay Unit 274K-2 into J12.
- j. Plug the connector on the pendent cable from Relay Unit 274K-2 into J13.

- k. Mount Power Supply 409X-2.
- l. Plug J14 into the plug on the 409X-2.
- m. Wire jumper connections on TB4 as desired for the specific installation. Use insulated wire for all jumpers. Jumper terminals CR and RELAY 1. Jumper other terminals as desired for control of studio lights and speakers. Refer to figure 4-5.
- n. A cue speaker is located in the 212G-1. If a different location is desired for the cue speaker, it

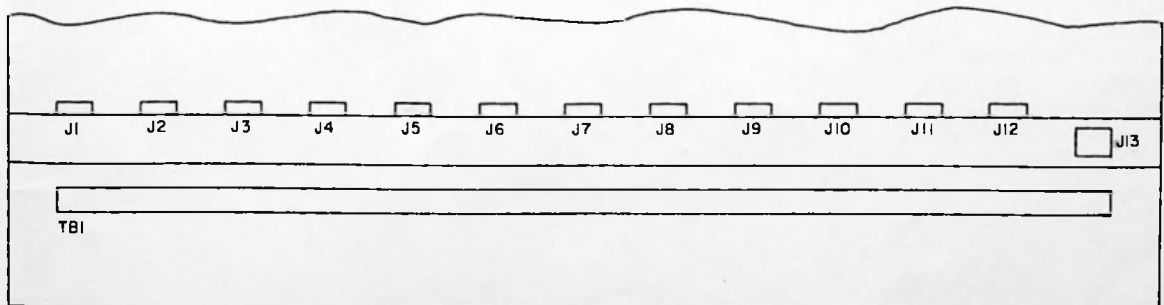

Figure 2-2. Broadcast Console 212G-1, Amplifier Connector Location

may be removed. A two-lug terminal strip is provided in the 212G-1 for making the necessary connections.

- o. Close the top and front panels.

2.2.4 INSTALLATION WIRING.

All connections to the 212G-1 are made with screw type terminals. All low-level audio input lines should be kept separate from the power and control wires. All wiring should be made with twisted shielded pairs preferably insulated and grounded at one end only. Audio lines should be a no. 20 or 22 AWG twisted

shielded pair. Studio circuit connections for signal lights should be made with a no. 16 AWG twisted shielded pair. Filament leads should be no. 12 AWG twisted pair. All connections should be made to the numbered terminal strip, TB1, located on the base plate of the console. The shields of the input lines should be grounded at the four 1/4-inch ground studs and lugs provided adjacent to the terminal strip. Refer to figure 2-1. Table 2-1 lists the line connections and their respective terminal numbers. If line 1 or line 2 (TB1, terminals 42 and 43, and 44 and 45) is not used, terminate unused line in a 600-ohm resistor.

TABLE 2-1. CONNECTIONS TO TERMINAL STRIP TB1

LINE	TB1 TERMINAL NUMBERS	LINE	TB1 TERMINAL NUMBERS
Spare	1	Program line 1	42 and 43
Low-level input A	2 and 3	Program line 2	44 and 45
Low-level input B	4 and 5	Spares	46 through 54
Low-level input C	6 and 7	Speaker no. 1 (or 600-ohm 10-w resistor)	55 and 56
Low-level input D	8 and 9	Speaker no. 2 (or 600-ohm 10-w resistor)	57 and 58
Control room mike input	10 and 11	Speaker no. 3 (or 600-ohm 10-w resistor)	59 and 60
Auxiliary input	12 and 13	Speaker no. 4 (or 600-ohm 10-w resistor)	61 and 62
Turntable input 1	14 and 15	Spares	63 and 64
Turntable input 2	16 and 17	ON AIR no. 1	65 and 66
Tape input 1	18 and 19*	OFF AIR no. 1	65 and 67
Ground	20	ON AIR no. 2	68 and 69
Spares	21 through 26	OFF AIR no. 2	68 and 70
Tape input 2	27 and 28*	OFF AIR no. 3	71 and 72
Net	29 and 30	OFF AIR no. 3	71 and 73
Remote input 1	31 and 32	ON AIR no. 4	74 and 75
Remote input 2	33 and 34	OFF AIR no. 4	74 and 76
Record output	35 and 36	115/230 v a-c for 409X-2	77 and 78
External monitor input	37 and 38*	115 v a-c for studio lights ON AIR-OFF AIR	79 and 80
External VU meter input	39 and 40		
Spare	41		

*Unbalanced inputs, 19, 28, and 38 grounded.

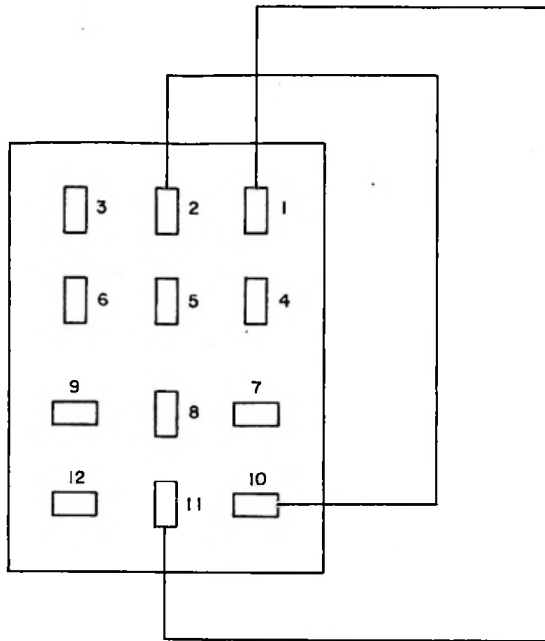

Figure 2-3. Jumper Plug Wiring Schematic Diagram

2.3 MODIFICATION AND INITIAL ADJUSTMENTS.

2.3.1 GENERAL.

Initial adjustments of Broadcast Console 212G-1 consist of input and output impedance selection, gain level selection of Program/Monitor Amplifier 356B-1, and d-c voltage adjustment of Power Supply 409X-2.

2.3.2 SELECTION OF IMPEDANCES.

Preamplifiers 356A-1 are factory wired for input impedance of 150 ohms and output impedance of 600 ohms. When Preamplifier 356A-1 is used as a booster amplifier, its input must be rewired for 250 ohms impedance. Refer to Preamplifier 356A-1 Instruction Book for rewiring information.

Program/Monitor Amplifier 356B-1 is factory wired for 600-ohm input and output impedances. For other desired input or output impedances, refer to Program/Monitor Amplifier 356B-1 Instruction Book.

2.3.3 GAIN ADJUSTMENT FOR PROGRAM/MONITOR AMPLIFIER 356B-1.

If Program/Monitor Amplifier 356B-1 is to be used as a program amplifier, 56 db gain is required, and the gain selection switch (S301) on the right front of the chassis (near P301) should be in the LOW position. If the 356B-1 is to be used as a monitor amplifier, the switch should be placed in the HIGH position to provide 68 db gain.

2.3.4 ADJUSTMENT OF 300 VOLTS D-C OUTPUT FROM POWER SUPPLY 409X-2.

A screwdriver adjustment, R401, on top of Power Supply 409X-2 chassis varies d-c output voltage. Adjust R402 until the output voltage is 300 volts d-c. Test points J1- and J2+ are provided on the top of the chassis to facilitate this adjustment. J1- is connected to B-, J2+ to the B+ output.

2.3.5 INITIAL ADJUSTMENTS FOR USE OF LIMITER AMPLIFIER 356E-1.

The following steps outline initial adjustments of Limiter Amplifier 356E-1 for a three-to-one compression ratio:

- a. Plug Limiter Amplifier 356E-1 into J8.
- b. Adjust Power Supply 409X-2 output for 300 volts d-c.
- c. With no input to the amplifier, make the adjustments of steps d through f.
- d. Set the METER switch to GR, and adjust the zeroing potentiometer, R47, for a 0 reading on the GR meter.
- e. Adjust R612 for 23.5 volts at the test jacks located on the 356E-1.
- f. Repeat step e after 30 minutes warmup.
- g. Set S601 at average.
- h. The GR meter and amplifiers now are ready to use. The GR meter will read the level of the input signal above the threshold when the METER switch is in the GR position. With the equipment adjusted as in step g, the 356E-1 will operate according to steps i through k.
- i. All signal below threshold (-44 vu) applied to the input of the 356E-1 will be amplified uniformly.
- j. All signals above threshold will be limited at a three-to-one compression ratio. For every 3 vu rise in input above the threshold level, the output level will increase 1 vu.

NOTE

Levels are specified in vu, implying a complex wave, such as a program waveform with high peaks. The peaks usually are assumed to be about 10 db above the sine wave peak. When testing with a sine wave input, it is normal to test at a level 10 db higher than normal vu level. With a signal level 10 db higher than normal level, the vu meter in the 212G-1 will be pinned. When testing at higher levels, disable the vu meter by setting the METER switch, S13, to EXT. Zero dbm is a power level of 1 milliwatt in 600 ohms.

- k. The desired amount of system limiting may be obtained by adjustment of Limiter Amplifier 356E-1. The average signal level may be maintained at threshold or above threshold according to the operator's preference. Table 2-2 gives typical values of the

input, output, and program line levels based on a 3-to-1 compression ratio, a 6-db line pad, and a 356E-1 with 54 db gain.

TABLE 2-2
LINE LEVELS

VU INPUT TO 356E-1	OUTPUT LEVEL 356E-1 (VU)	LINE LEVEL IN VU
-44*	+10	+4
-39	+11.5	+5.5
-34	+13	+7
-30.67	+14	+8
-29	+14.5	+8.5
-24	+16	+10
*Threshold		

NOTE

Assuming 3:1 ratio, 6 db line pad, 54 db gain in 356E-1.

NOTE

The vu meter will indicate 0 vu at +14 vu program amplifier output. If it is desired to change the operating level of the 356E-1, the vu meter pad must be modified.

2.3.6 MONITOR EXTERNAL CIRCUIT LEVEL WITH VU METER.

External levels may be monitored by connecting the circuit to be metered at terminals 39 and 40 of TB1.

NOTE

External circuit must include a fixed or variable meter pad. For fixed pad values see figure 2-4. Variable pads, Collins part number 378 0011 00 or Daven 7500/3900 ohm vu meter attenuator, may be used.

2.3.7 RESISTOR VALUES FOR FIXED PADS.

The vu meter, M1, and its pad are connected to the program line between the program amplifier and LINE switch S10. A 6-db pad in the line provides isolation between the program amplifier and the output line. The line pad consists of R42, R43, R44, R45, and R46. A 7500/3900-ohm pad made up of resistors R48, R49, and R50 serves as a meter multiplier. As shipped, vu meter M1 will indicate 0 vu at a program level of +8 vu, which normally is a standard level for program lines. With a +8 vu level at the program line, the program amplifier output level is +14 vu. The meter pad consisting of R48, R49, and R50 has a 10-db loss which provides +4 vu at the meter terminals. A level of +4 vu will indicate 0 vu on the meter (minimum value). The pad resistors are located on TB3 which is mounted on the left side of the console when viewed from front.

If a program line level other than +8 vu is used, the pads must be modified. Table 2-3 gives selected resistor values for vu meter pads. Only calculated values of resistance are shown, but the nearest standard value of resistance may be substituted without seriously affecting the attenuation through the pad.

TABLE 2-3
LINE LEVELS

VU LEVEL FOR 0 VU ON METER	R48	R49	R50
18	6203	2603	1620
16	5934	2334	2091
14	5626	2026	2741
12	5279	1679	3690
10	4896	1296	5221
8	4482	882	8177
6	4047	447	16,788
4	3600	0	Open

The level given is the level at the output of the program amplifier and is higher than the program line by the decibel attenuation in the line pad. A typical example would be a desired program line level of +4 vu and a line pad of 6 db. The level at the output of the program amplifier will be +10 vu and resistor values for the meter pad will be R48, 4896 ohms; R49, 1296 ohms; and R50, 5221 ohms.

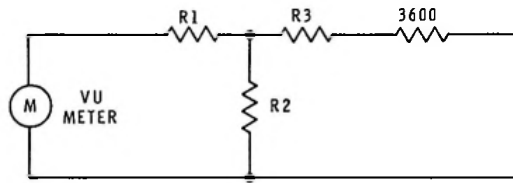

RESISTANCE VALUES IN OHMS				
LEVEL TO BE METERED	PAD LOSS FOR 0 VU READING	R1	R2	R3
+ 4DBM	0	0	OPEN	0
+10DBM	6DB	1296	5221	1296
+32DBM	28DB	3601	311	3601
+39DBM	35DB	3764	139	3764

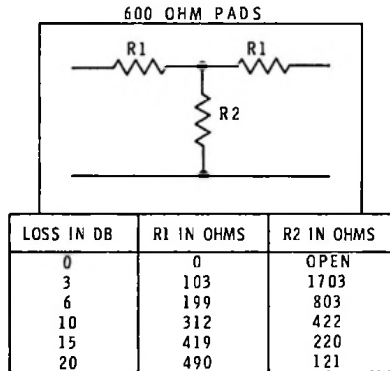

Figure 2-4. Resistor Values for Fixed Pads

NOTE

Above levels are specified in vu, implying a complex wave, such as a program waveform with high peaks. It usually is assumed that the peaks are 10 db above the sine wave peak. When testing with a sine wave input, it is normal to test at a level 10 db higher than normal level. At this 10-db higher level, the 212G-1 vu meter, M1, will be pinned if it is left in the circuit. When testing at higher levels, disable vu meter by setting the METER switch S13 to EXT.

2.3.8 SUGGESTED FUNCTION FOR SPARE SWITCHES.

Spare switches may be wired for switching the following:

- a. Override.
- b. Tape recorder.
- c. Headphones.

- d. Vu meter.
- e. Auxiliary input or output circuits.

2.3.9 SPEAKER AND WARNING LIGHT CONTROL CIRCUITS.

A simplified schematic diagram of the speaker and warning light control circuits is shown in figure 4-5. Mixer key switches S11 and S12 and program/audition switches S1 through S6 control application of 12 volts d-c to relays located in Relay Unit 274K-2. Mixer circuit wiring may be modified easily for specific station applications. Cue speaker LS1 in the console is removed from the circuit by MIXER 3 A/P switch S3 whenever the control room microphone is in use.

NOTE

If this interlock feature is not desired, jumper contacts 14 and 20 on S3. A jack may be placed in the cue speaker line so that the speaker is muted when a headset is plugged into the jack.

SECTION III OPERATION

3.1 CONTROL FUNCTIONS.

3.1.1 MIXER.

Refer to figure 3-1. The nine mixer controls are located near the lower edge of the front panel of Broadcast Console 212G-1. They are identified by silk-screening as MIXER 1 through MIXER 9. Above each mixer control knob is located an audition/program (A/P) switch. The mixer controls adjust the signal levels fed to the program or audition circuits. MIXERS AT4 through AT9 are provided with CUE positions.

NOTE

Mixers should not be set in CUE position (extreme counterclockwise), except when this function is in use.

3.1.2 MIXER SELECTOR SWITCHES.

Two mixer selector switches, S11 and S12, are located on the left-hand side near the top of the panel; they are identified as MIXER 1 and MIXER 2. MIXER 1 and MIXER 2 switches each select one of two low-level input lines to be fed to the preamplifiers. The panel designations for these switches are silk-screened on the front panel.

3.1.3 PROGRAM/AUDITION SELECTOR SWITCHES.

Above each mixer control is located a program/audition selector switch. They are identified on the

panel by a silk-screened "A" to the left of the switch and a "P" to the right. These silk-screened letters indicate whether the input is being switched to program (P) or audition (A). The center position is "off."

3.1.4 GAIN CONTROLS.

The MONITOR gain control, AT11, is located near the top, in the center of the left-hand portion of the front panel. The MASTER gain control, AT10, is located in the lower right-hand corner of the front panel. MONITOR gain control AT11 adjusts the input level to the monitor amplifier and MASTER gain control AT10 adjusts the input level to the program amplifier. CUE gain control R58 is located to the left of the meter. This control adjusts the input level to Cue Amplifier 356Q-1. The panel designations for these controls are silk screened on the front panel.

3.1.5 MIXER 9 NET/REMOTE SWITCH.

MIXER 9 NET/REMOTE switch S14 is located in the upper right corner of the front panel. In the NET position, the network line is tied into the mixer 9 input circuit where the network line may be switched to program or audition. In the REMOTE position, mixer 9 is connected to remote function selector switches REMOTE 1 and REMOTE 2, S15 and S16.

3.1.6 REMOTE FUNCTION SELECTOR SWITCHES.

The remote function selector switches, S15 and S16, are identified as REMOTE 1 and REMOTE 2, and are

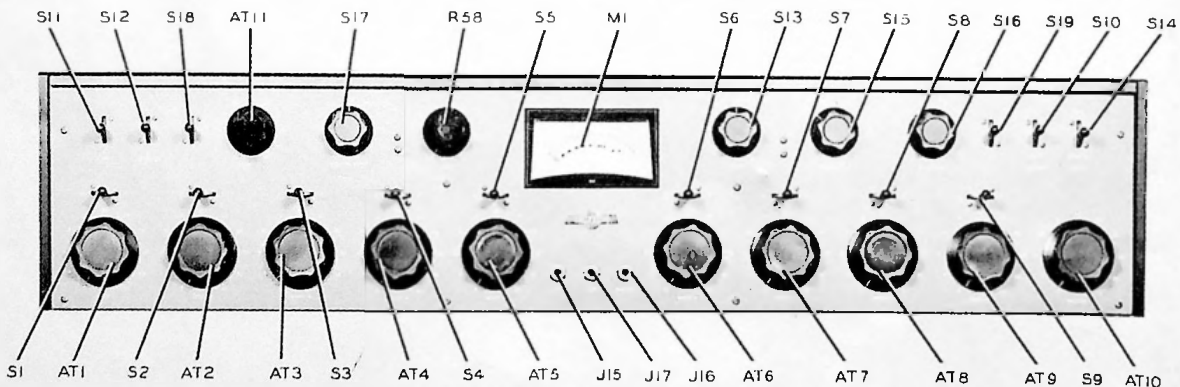

Figure 3-1. Broadcast Console 212G-1, Control Locations

located near the top, in the center of the right-hand portion of the front panel. Each has OFF, MON, CUE, and MIX positions. When both the audition/program switch and a REMOTE switch are set at OFF, the remote line is terminated in a resistive load. When a REMOTE switch is in the MON position, its remote line may be monitored by phones connected at the REMOTE monitor jack, J16. When one of the switches is in the CUE position, the cueing signal from the monitor amplifier may be fed back into the remote line for remote cue. In the MIX position, the signal from the associated remote line is sent to mixer 9 input when S14 is in the REMOTE position.

3.1.7 MONITOR INPUT SWITCH.

MONITOR INPUT switch S17 is located near the top and center of the left-hand portion of the front panel. It has AUD, PGM, and EXT positions. The AUD position permits the MONITOR level control and monitor amplifier to be connected to the monitor booster amplifier. When the MONITOR INPUT switch is in the PGM position, the program line is connected through a bridging pad to the MONITOR level control and monitor amplifier input. The EXT position permits a signal connected at terminals 37 and 38 of TB1 to be monitored through the MONITOR level control and monitor amplifier.

3.1.8 METER INPUT SWITCH.

The METER switch, S13, is located to the right of the meter near the top of the front panel. It has GR, VU, and EXT positions. If Limiter Amplifier 356E-1 is used, the GR position provides indication of the gain reduction in decibels above threshold. In the VU position, the vu meter is connected to the output of the Program/Monitor Amplifier 356B-1. In the EXT position, the vu meter is connected to terminals 39 and 40 of TB1.

3.1.9 PROGRAM SWITCH.

The PROGRAM switch, S10, permits switching either LINE 1 or LINE 2 to the program channel. In the middle position, the program channel is terminated in a resistive load.

3.1.10 SPARE SWITCHES.

Two spare level switches, S18 and S19, are provided to be used as desired in any custom wiring. One is located to the left of the PROGRAM switch in the upper right portion of the front panel. The other is located to the right of the MIXER 2 switch. Refer to paragraph 2.3.8 for suggested functions for these switches.

3.2 OPERATING PROCEDURES.

3.2.1 ROUTINE OPERATION.

3.2.1.1 LOCAL PROGRAM ON THE AIR. The procedure to put a local program on the air is as follows:

a. Select desired microphone inputs with the mixer selector switches, if applicable.

b. Move the PROGRAM switch, S10, to LINE 1 or LINE 2 as desired.

c. Set MASTER control, AT10, to 24.

d. Rotate MONITOR INPUT switch, S17, to the PGM position.

e. Move mixer key switches as required to the P position.

f. Turn up applicable MIXER as required to desired level as indicated on VU meter.

g. Adjust the level of monitor speakers as desired by use of MONITOR gain control, AT11.

3.2.1.2 AUDITION PROGRAM. The procedure to audition program is as follows:

a. Select desired microphone inputs with the mixer selector switches if applicable.

b. Move mixer key switches to the A position.

c. Turn up the corresponding mixer controls.

d. Set the MONITOR INPUT Switch, S17, to AUD.

e. The audition may be heard over the monitor speakers. The level may be adjusted by means of the MONITOR GAIN control, AT11.

3.2.2 REMOTE LINE OPERATION.

3.2.2.1 REMOTE PROGRAM ON THE AIR. The following procedures are necessary to put a remote line on the air:

a. Move MIXER 9 NET/REMOTE switch, S14, to REMOTE.

b. Set associated REMOTE switch, S15 or S16, to MIX.

c. Set MIXER 9 program/audition switch, S9, to P.

d. Move PROGRAM switch, S10, to place program on desired line.

e. Adjust MIXER 9, AT9, for proper level.

3.2.2.2 FEED CUE SIGNAL AND SWITCH REMOTE LINE TO ON THE AIR. To feed cue signal and switch remote line to on the air, set up as previously described for putting remote line on air, except set REMOTE function switch S15 or S16 to CUE. The cue signal is then fed from the monitor amplifier through the function switch to the remote line. When the cue is sent, the control room operator switches the REMOTE function switch S15 or S16 from CUE to MIX, and the remote line is on the air.

3.2.2.3 RECORD OPERATION. For normal record operation, an external recorder is connected to TB1, connectors 35 and 36. The record output is taken from the audition booster amplifier connected to J10 when MONITOR INPUT switch, S17, is in the AUD position.

NOTE

Disconnect recorder from terminals 35 and 36 of TB1 when not in use.

For recording network program while a local program is on the air, the following operating procedures may be used.

- a. Move MIXER 9 A/P switch, S9, to A.
- b. Move MIXER 9 NET/REMOTE switch, S14, to NET.
- c. Adjust MIXER 9 for desired level at terminals 35 and 36 TB1.

3.2.2.4 TALK-BACK OPERATION USING SPEAKERS. The following operating procedures are necessary for the control room operator to listen to a remote line when a speaker is used.

- a. Move MIXER 9 A/P switch, S9, to A.
- b. Set MONITOR INPUT switch, S17, to AUD.
- c. Move MIXER 9 NET/REMOTE switch, S14, to REMOTE.
- d. Set applicable REMOTE line switch, S15 or S16, to MIX.
- e. Adjust MONITOR gain control, AT11, and MIXER 9, AT9, for desired listening level.

f. The following operating procedures are necessary for the control room operator to talk to the remote operator: Set MONITOR INPUT switch, S17, to AUD. Move MIXER 3 A/P switch, S3, to A. Set Applicable REMOTE line switch, S15 or S16 at CUE. Adjust MONITOR gain control, AT11, for suitable remote listening level.

3.2.2.5 TALK-BACK OPERATION USING HEADPHONES. The following operating procedures are necessary for the control room operator to communicate with a remote line operator when headphones are used.

- a. Plug headphones into REMOTE jack, J16.
- b. Set MIXER 3 A/P switch, S4, to A.
- c. Move MONITOR INPUT switch, S17, to AUD.
- d. Adjust MONITOR gain control, AT11, for desired listening level.
- e. For the control room operator to talk to the remote operator, move the applicable REMOTE line switch, S15 or S16, to CUE. For the control room operator to listen to the remote operator, move the applicable REMOTE line switch, S15 or S16, to MON.

SECTION IV

PRINCIPLES OF OPERATION

4.1 GENERAL.

A functional block diagram of a typical Broadcast Console 212G-1 is shown in figure 4-1. Amplifiers of the plug-in module type may be added, as necessary, to handle up to nine of 13 possible inputs and serve one of two output lines. Lever switches permit the selection of two possible sources for two of six of the low-level input attenuators. The remote input attenuator may be switched to three possible inputs. The output of each step type attenuator is connected to a key switch which can feed either the program or the audition line. During normal program operation, the monitor line can be used for audition purposes. Output from the two-stage Preamplifier 356A-1 is passed through a constant impedance attenuator before being switched to the program or audition circuit. Connections for control room speakers and warning lights must be interlocked with the third mixer key switch (MIXER 3) and remote and cue functions to prevent program interruptions. Studio speakers can be interlocked with other mixer keys. The program line can be monitored with vu meter M1. Cueing signals from cue positions on MIXERS 4, 5, 6, 7, 8, and 9 are available when Cue Amplifier 356Q-1 is plugged into J9. A CUE speaker level control is provided on the front panel and a cue speaker is provided in the console.

4.2 MIXER CIRCUITS.

Refer to figures 4-2 and 7-1. Nine independent input circuits are provided. Six are low-level microphone

or turntable inputs, each having an individual two-stage preamplifier. One remote net and two medium-level inputs are provided. The mixing circuits maintain the correct impedance relationship at all times, and the volume level in any specific circuit is independent of mixing and switching operations in other circuits. Attenuators AT1 through AT9 control the input levels to the mixing circuits. Each is a constant-impedance attenuator with 600:1200 impedance ratio. Resistors R20 through R37 compensate for changes of impedance at the mixer bus when one or more of the mixers is out of the circuit. Mixer controls and terminating resistors introduce approximately 15 db loss. Contacts on the mixer and channel key switches complete 12-volt d-c circuits to operate the speaker and warning light control relays K701 through K704. These circuits should be interlocked to prevent program interruption. Talk back from the control room into any one of the studios or into the remote lines not in use is possible by key switch control.

4.3 PROGRAM CIRCUITS.

Input signals connected into the program line are applied to the input of the booster amplifier. The booster amplifier is a type 356A-1 with input terminals connected for 250 ohms impedance. The booster amplifier plugs into J7. Output from the booster amplifier is attenuated by the MASTER gain control AT10. Output from the program amplifier is isolated from the program lines by a 6-db pad. The pad consists of resistors R42, R43, R45, and R46. Nominal

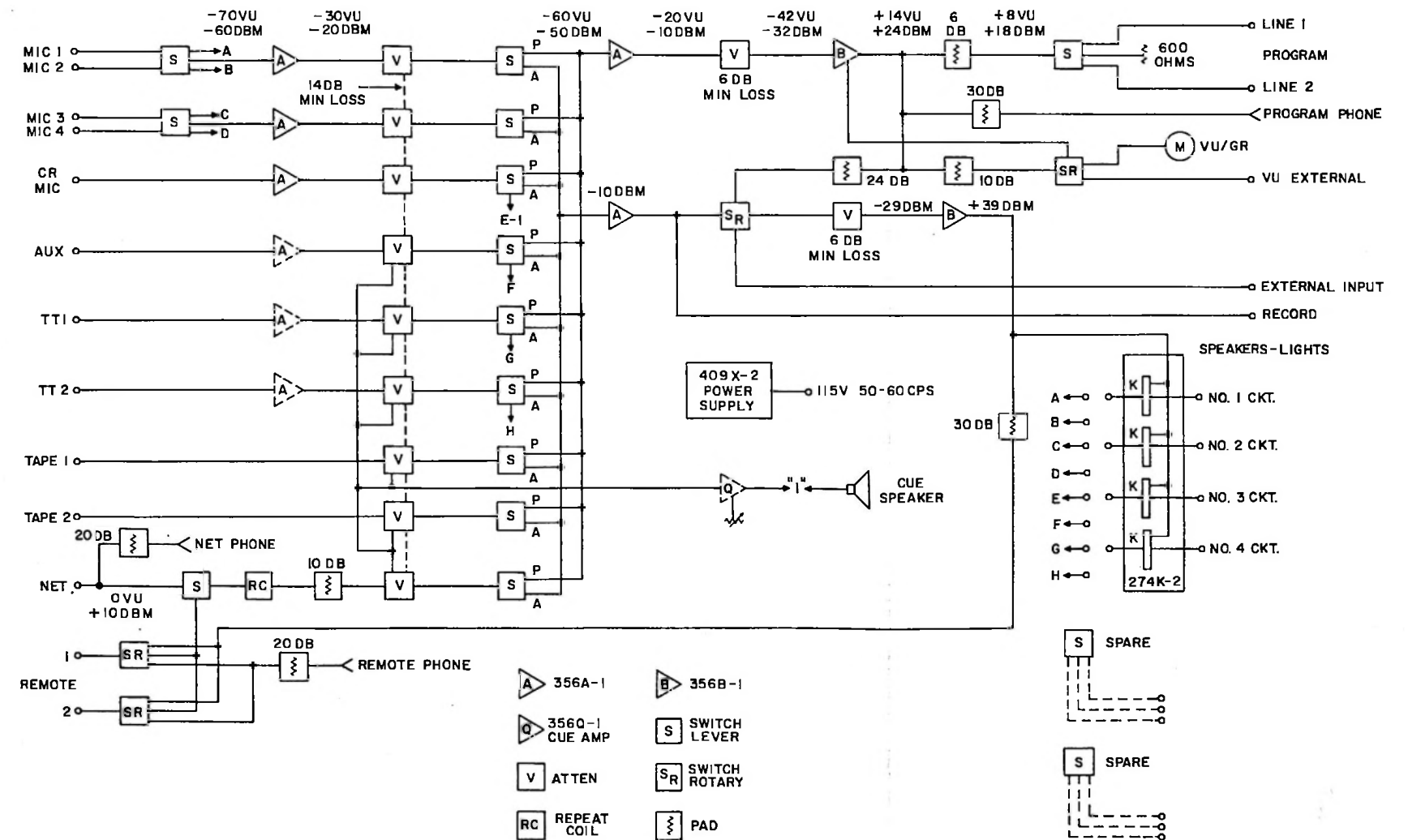

Figure 4-1. Broadcast Console 212G-1, Functional Block Diagram

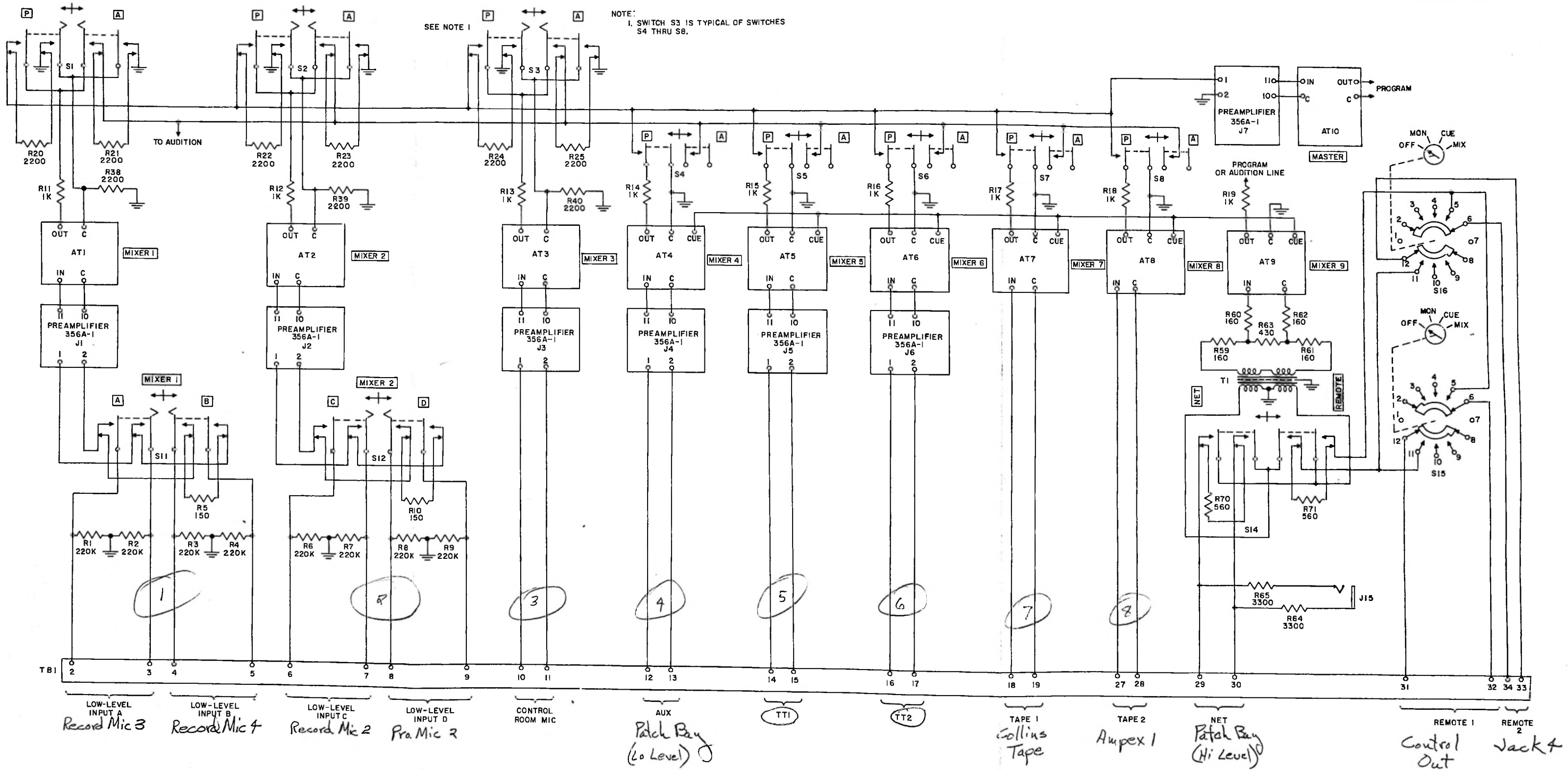

Figure 4-2. Mixer Circuits, Simplified Schematic Diagram

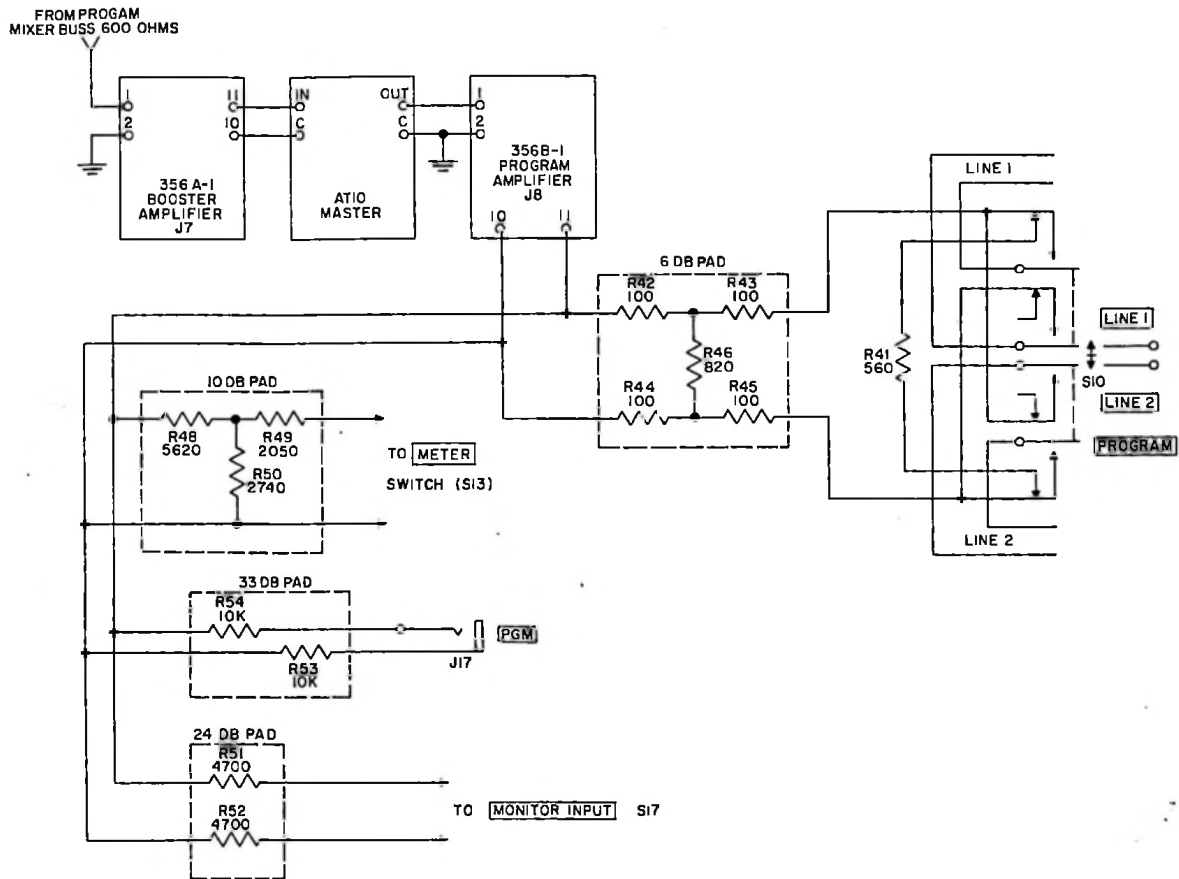

Figure 4-3. Program Circuits, Simplified Schematic Diagram

signal levels are -50 dbm at the input to the booster amplifier, -10 dbm at the output of the booster amplifier, -32 dbm at the input of the program amplifier, +24 dbm at the program amplifier output, and +18 dbm at the program line. The signal from the output of the program amplifier (+24 dbm) is connected through a 6-db pad and a LINE switch, S10, to the output line connections of the console. The program amplifier output also is applied through pads, to the MONITOR INPUT switch, S17, and the PGM phone jack, J17. The VU METER INPUT switch, S13, connects the VU meter, M1, through a pad to monitor the output of the program amplifier. Figure 4-3 is a simplified schematic diagram of the program circuits.

4.4 MONITOR CIRCUITS.

Refer to figure 4-4. The MONITOR INPUT selector (S17) has three positions: AUD, PGM, and EXT. When the switch is in the EXT position, a signal connected at terminals 37 and 38 of TB1 may be monitored. With the switch in the PGM position, the program line

can be monitored. With the MONITOR INPUT switch in the AUD position and a mixer key in position A, the audition bus will be connected to the monitor circuit.

4.5 STUDIO SPEAKER AND WARNING LIGHT CONTROL CIRCUITS.

Refer to figure 4-5. Mixer circuit key switches S11 and S12 and audition/program switches S1 through S6 control application of 12 volts d-c to relays K701 through K704.

The switches must be interlocked electrically to prevent program interruption. Speakers are operated from the 600-ohm output of Program/Monitor Amplifier 356B-1. Resistors R701, R702, R703, and R704 are connected as terminating resistors when speakers are removed from the circuit. Contacts on relays K701 through K704 control the application of 115 volts a-c to the ON AIR and OFF AIR warning lights. Wiring modifications may be necessary to meet individual station requirements.

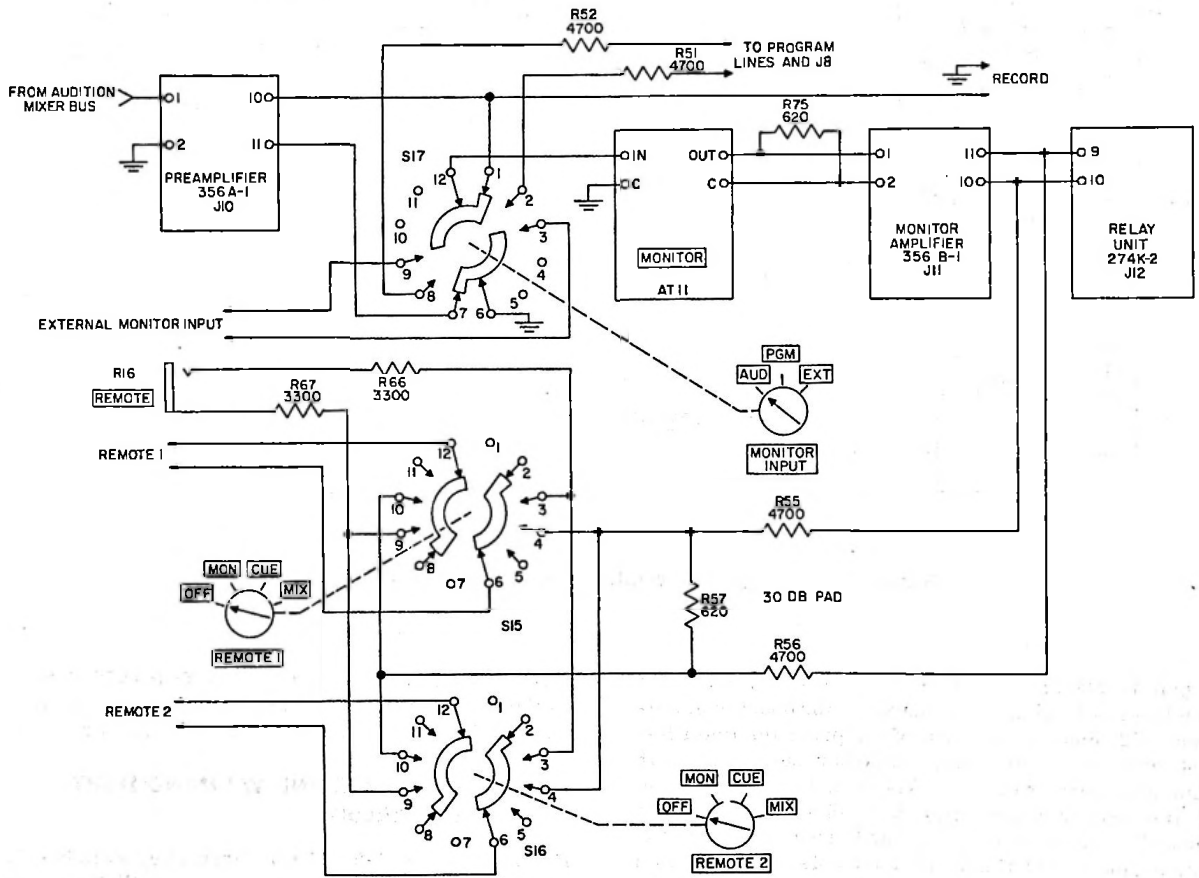
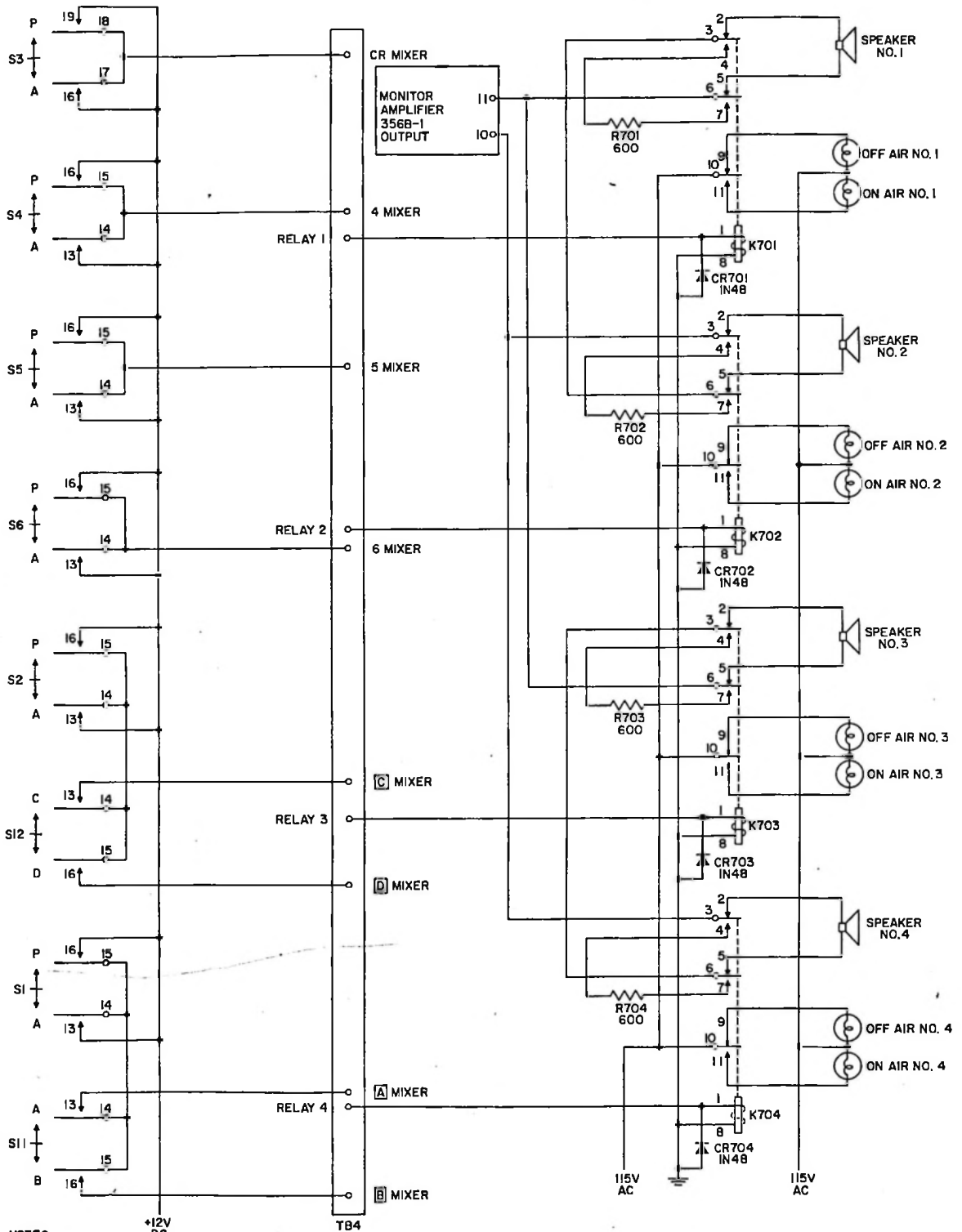

Figure 4-4. Monitor Circuits, Simplified Schematic Diagram



NOTES

1. A JUMPER MUST BE PLACED FROM CR MIXER TO RELAY 1 ON TB4 WHEN SPEAKER NO. 1 IS LOCATED IN THE CONTROL ROOM. ADDITIONAL JUMPERS MUST BE PLACED BETWEEN RELAYS 2, 3, 4 AND THE ASSOCIATED MIXER WHEN THERE IS A SPEAKER IN A STUDIO WITH A MICROPHONE.
2. IF MORE THAN ONE MICROPHONE IS USED IN A SPECIFIC LOCATION, THE SWITCH CONTACTS FOR EACH SHOULD BE PARALLELED & JUMPED ON TB4 SO THAT EITHER MICROPHONE WILL OPERATE THE ASSOCIATED RELAY.

Figure 4-5. Speaker and Warning Light Control Circuits, Simplified Schematic Diagram

SECTION V MAINTENANCE

5.1 PERIODIC INSPECTION AND PREVENTIVE MAINTENANCE.

5.1.1 ATTENUATORS.

Clean all attenuators occasionally to avoid noisy operation.

- a. Remove the dust cover.
- b. Wipe each contact and contact arm with a lint-free cloth that is saturated with carbon tetrachloride.
- c. Apply a thin film of contact lubricant such as Daven oil or equivalent.
- d. Replace and secure dust cover.

5.1.2 KEY SWITCHES.

The contacts of the key switches should be cleaned occasionally with a burnishing tool. Be careful not to bend any of the leaf springs.

5.1.3 WIRING.

Check all wiring for loose connections and frayed insulation. Make certain that all terminal strip screws are tight.

5.2 TROUBLE SHOOTING.

5.2.1 GENERAL.

A test cable is furnished with the Broadcast Console 212G-1. When one of the amplifiers is plugged into

the test cable connector and the cable is plugged into the console, the amplifier may be turned upside down for testing and maintenance.

NOTE

To remove an amplifier module, lift the rear edge of the module clear of the retaining rail, and push toward the rear to unplug.

Refer to the instruction book for the individual module for trouble-shooting and maintenance procedures. All subassembly instruction books are supplied following section VII of this instruction book.

5.2.2 REPLACEMENT OF METER LAMPS.

The two lamps are located inside the 212G-1 front panel. Both are mounted on a bracket that is accessible when the front panel is tilted forward.

5.2.3 EXCESSIVE DISTORTION.

If excessive distortion is noted, it may be due to an unbalanced condition in the push-pull output stage of the 356B-1 Program/Monitor Amplifier. Replace tubes V303 and V304.

SECTION VI PARTS LIST

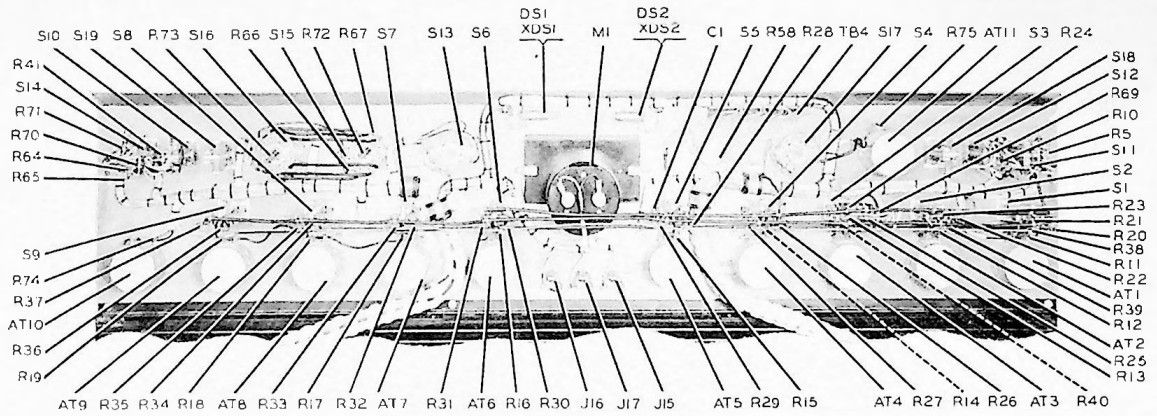

Figure 6-1. Broadcast Console 212G-1, Front Panel, Rear View

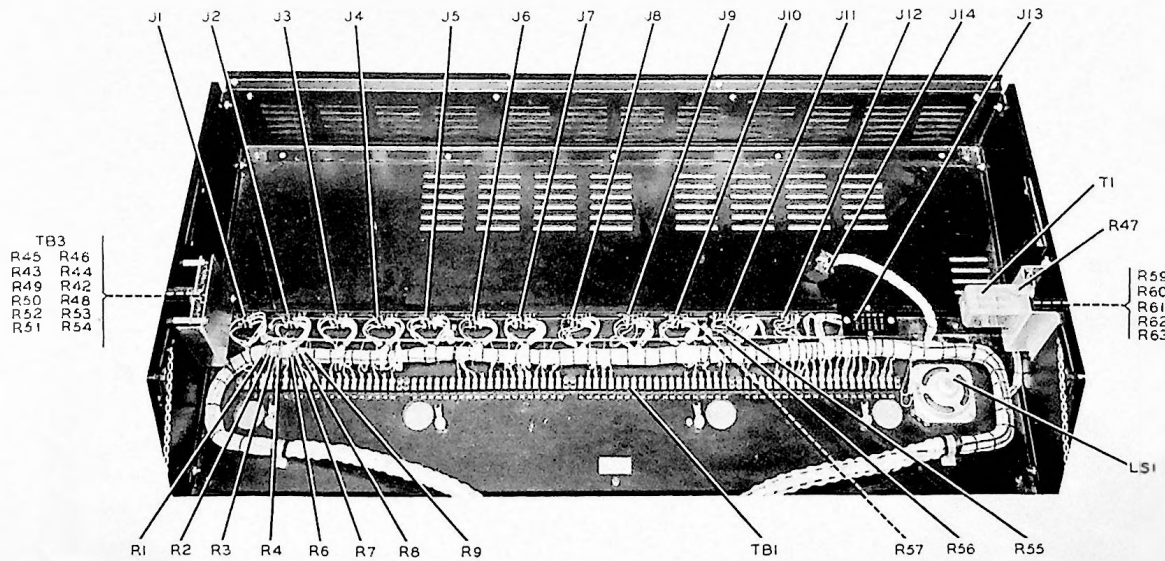

Figure 6-2. Broadcast Console 212G-1, Inside View

ITEM	DESCRIPTION	COLLINS PART NUMBER
BROADCAST CONSOLE 212G-1		522 1605 00
AT1	ATTENUATOR, VARIABLE: resistive type, 600/1200 ohms nom impedance, 20 steps, 2 db per step, 1-27/32 in. dia, 2-23/32 in. lg	378 0368 00
AT2	ATTENUATOR, VARIABLE: same as AT1	378 0368 00
AT3	ATTENUATOR, VARIABLE: same as AT1	378 0368 00
AT4	ATTENUATOR, VARIABLE: resistive type, 600/1200 ohms impedance, 20 steps attenuation in infinity, cueing position, 1-27/32 dia, 2-23/32 in. lg	378 0367 00
AT5 thru AT9	ATTENUATOR, VARIABLE: same as AT4	378 0367 00
AT10	ATTENUATOR, VARIABLE: resistive type, 600/600 ohms impedance 20 steps, 2 db each step, last step infinity	378 0530 00
AT11	ATTENUATOR, VARIABLE: same as AT10	378 0530 00
C1	CAPACITOR, FIXED, CERAMIC: 10,000 uuf, +100% -20%, 500 v dc	913 1188 00
DS1	LAMP, INCANDESCENT: 6.3 v, 0.945 w, 0.15 amps; 1-1/8 in. lg max overall	262 3240 00
DS2	LAMP, INCANDESCENT: same as DS1	262 3240 00
J1	CONNECTOR, RECEPTACLE, ELECTRICAL: 12 flat female 10 amps, 730 v; straight shape	366 2120 00
J2 thru J12	CONNECTOR, RECEPTACLE, ELECTRICAL: same as J1	366 2120 00
J13	CONNECTOR, RECEPTACLE, ELECTRICAL: 15 female contacts, chassis mtg, 3/4 in. by 1-5/8 in. by 1-21/32 in. overall	366 2150 00
J14	CONNECTOR, RECEPTACLE, ELECTRICAL: same as J13	366 2150 00
J15	JACK: telephone; for 2 conductor plug 1/4 in. dia. barrel	358 1080 00
J16	JACK: same as J15	358 1080 00
J17	JACK: same as J15	358 1080 00
LS1	LOUDSPEAKER, PERMANENT MAGNET: 3 to 4 ohms max. voice-coil impedance; 3 w nominal input; 3 in. sq.	371 0217 00
M1	METER, AUDIO LEVEL: db; top scale -20 thru 0, black, and +1 to +3 red markings CW; bottom scale 0 thru 100 and db gain reduction scale, black; phenolic case, 4 in. by 5 in. rectangular, flush panel mtg.	456 0053 00
P1	PLUG, JUMPER: 12 prong male connector	541 8459 002
P501	CONNECTOR, PLUG: 12 flat male contacts, 10 amps, 730 v ac; 1 mating end; plastic dielectric; straight shape	365 8120 00
P502	CONNECTOR, RECEPTACLE, ELECTRICAL: 12 flat female contacts; 1 mating end; straight shape polarized; nonlocking; 15/16 in. by 1-3/16 in. by 1-1/4 in.	366 8120 00
R1	RESISTOR, FIXED, COMPOSITION: 0.22 meg-ohms, ±10%, 1/2 w	745 1450 00
R2 thru R4	RESISTOR, FIXED, COMPOSITION: same as R1	745 1450 00
R5	RESISTOR, FIXED, COMPOSITION: 150 ohms, ±10%, 1/2 w	745 1317 00
R6 thru R9	RESISTOR, FIXED, COMPOSITION: same as R1	745 1450 00
R10	RESISTOR, FIXED, COMPOSITION: same as R5	745 1317 00
R11	RESISTOR, FIXED, COMPOSITION: 1000 ohms, ±10%, 1/2 w	745 1352 00
R12 thru R19	RESISTOR, FIXED, COMPOSITION: same as R11	745 1352 00
R20	RESISTOR, FIXED, COMPOSITION: 2200 ohms, ±10%, 1/2 w	745 1366 00
R21 thru R40	RESISTOR, FIXED, COMPOSITION: same as R20	745 1366 00
R41	RESISTOR, FIXED, COMPOSITION: 560 ohms, ±10%, 1 w	745 3342 00
R42	RESISTOR, FIXED, COMPOSITION: 100 ohms, ±5%, 1 w	745 3309 00
R43 thru R45	RESISTOR, FIXED, COMPOSITION: same as R42	745 3309 00
R46	RESISTOR, FIXED, COMPOSITION: 820 ohms, ±5%, 2w	745 5648 00
R47	RESISTOR, VARIABLE, COMPOSITION: 1000 ohms, ±20% 0.3 w	376 0203 00

ITEM	DESCRIPTION	COLLINS PART NUMBER
R48	RESISTOR, FIXED, FILM: 5620 ohms, ±1%, 1/2 w	705 7632 00
R49	RESISTOR, FIXED, FILM: 2,050 ohms ±1%, 1/2 w	705 7611 00
R50	RESISTOR, FIXED, FILM: 2,740 ohms, ±1%, 1/2 w	705 7617 00
R51	RESISTOR, FIXED, COMPOSITION: 4700 ohms, ±10%, 1/2 w	745 1380 00
R52	RESISTOR, FIXED, COMPOSITION: same as R51	745 1380 00
R53	RESISTOR, FIXED, COMPOSITION: 10,000 ohms, ±10%, 1/2 w	745 1394 00
R54	RESISTOR, FIXED, COMPOSITION: same as R53	745 1394 00
R55	RESISTOR, FIXED, COMPOSITION: 4700 ohms, ±5%, 1/2 w	745 1370 00
R56	RESISTOR, FIXED, COMPOSITION: same as R55	745 1379 00
R57	RESISTOR, FIXED, COMPOSITION: 620 ohms, ±5%, 1/2 w	745 1343 00
R58	RESISTOR, VARIABLE, COMPOSITION: 50,000 ohms, ±30%, 1/4 w	376 7204 00
R59	RESISTOR, FIXED, COMPOSITION: 160 ohms, ±5%, 1/2 w	745 1319 00
R60 thru R62	RESISTOR, FIXED, COMPOSITION: same as R59	745 1319 00
R63	RESISTOR, FIXED, COMPOSITION: 430 ohms, ±5%, 1/2 w	745 1336 00
R64	RESISTOR, FIXED, COMPOSITION: 3300 ohms, ±10%, 1/2 w	745 1373 00
R65 thru R67	RESISTOR, FIXED, COMPOSITION: same as R64	745 1373 00
R68	NOT USED	
R69	RESISTOR, FIXED, COMPOSITION: 10 ohms, ±10%, 2 w	745 5568 00
R70 thru R73	RESISTOR, FIXED, COMPOSITION: same as R41	745 3342 00
R74	RESISTOR, FIXED, COMPOSITION: 560 ohms, ±10%, 1/2 w	745 1342 00
R75	RESISTOR, FIXED, COMPOSITION: same as R74	745 1342 00
S1	SWITCH, LEVER: 3 positions; upper, left 2D, Right 1A; Lower, left 2D, right 1A; 3 amps, 110 VAC noninductive	375 0175 00
S2	SWITCH, LEVER: same as S1	375 0175 00
S3	SWITCH, LEVER: 3 positions; upper, left 2D, Right 1C, 1A; lower, left 2D, right 1C, 1A; 3 amps 110 VAC noninductive	375 0177 00
S4 thru S6	SWITCH, LEVER: same as S1	375 0175 00
S7	SWITCH, LEVER: 3 position; upper, left 2D; lower left 2D; 3 amps, 110 VAC noninductive	375 0176 00
S8 thru S10	SWITCH, LEVER: same as S7	375 0176 00
S11	SWITCH, LEVER: same as S1	375 0175 00
S12	SWITCH, LEVER: same as S1	375 0175 00
S13	SWITCH, ROTARY: 2 pole, 3 positions, 1 section; 2 moving contacts, 8 fixed contacts	259 1138 00
S14	SWITCH, LEVER: 3 positions; upper, left 2D, right 2 dummy clips; lower, left 2D, right none; 3 amps, 110 VAC noninductive	375 0178 00
S15	SWITCH, ROTARY: 2 pole, 4 positions, 1 section; 2 moving contacts, 10 fixed contacts	259 1121 00
S16	SWITCH, ROTARY: same as S15	259 1121 00
S17	SWITCH, ROTARY: same as S13	259 1138 00
S18	SWITCH, LEVER: same as S7	375 0176 00
S19	SWITCH, LEVER: same as S3	375 0177 00
TB1	TERMINAL STRIP: molded bakelite barrier strip, 20 terminals, 7-7/8 in. lg by 7/8 in. w, 0.656 in. thk	367 0131 00
TB2	TERMINAL, BOARD: phenolic 1/16 in. thk, 3/8 in. w by 1-1/8 in. lg overall excluding terminals	306 0168 00
TB3	TERMINAL BOARD: plastic 3/32 in. thk, 3-3/8 in. w by 4-5/16 in. lg incl 26 brass silver plated double end terminal lugs	545 8014 003
TB4	TERMINAL, BOARD: plastic 1/16 in. thk, 7/16 in. long, 12 brass solder lug type terminals	367 0905 00
TB5	TERMINAL, BOARD: phenolic 1/16 in. thk., 3/8 in. w by 1-1/8 in. lg. overall excluding terminals	306 0168 00
TB6	TERMINAL, BOARD: same as TB5	306 0168 00
TB7	TERMINAL, BOARD: same as TB5	306 0168 00
XDS1	LAMPHOLDER: steel, cadmium plated, single contact, bayonet type w/ bracket mtg; phenolic insulation; 1-1/16 in. w by 1-25/32 in. lg overall	262 0297 00
XDS2	LAMPHOLDER: same as XDS1	262 0297 00

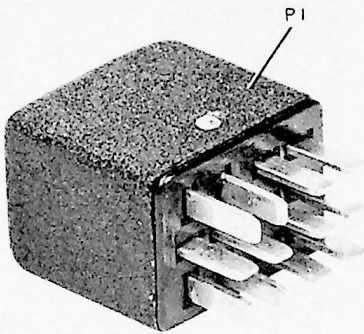

Figure 6-3. Jumper Plug

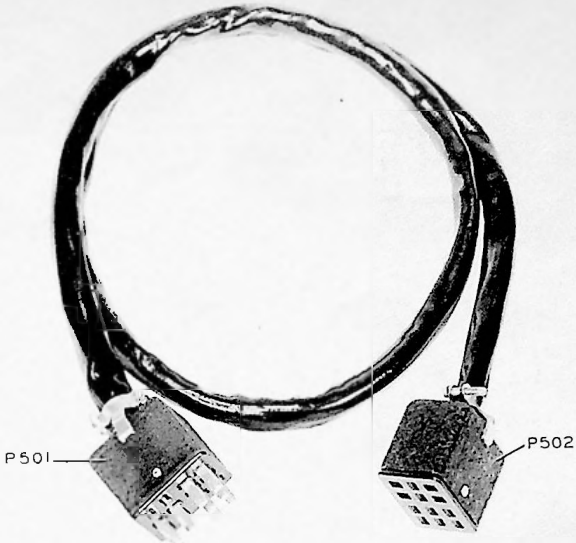

Figure 6-4. Test Cable

16-18-19-20-

20-27

337

SECTION VII ILLUSTRATIONS

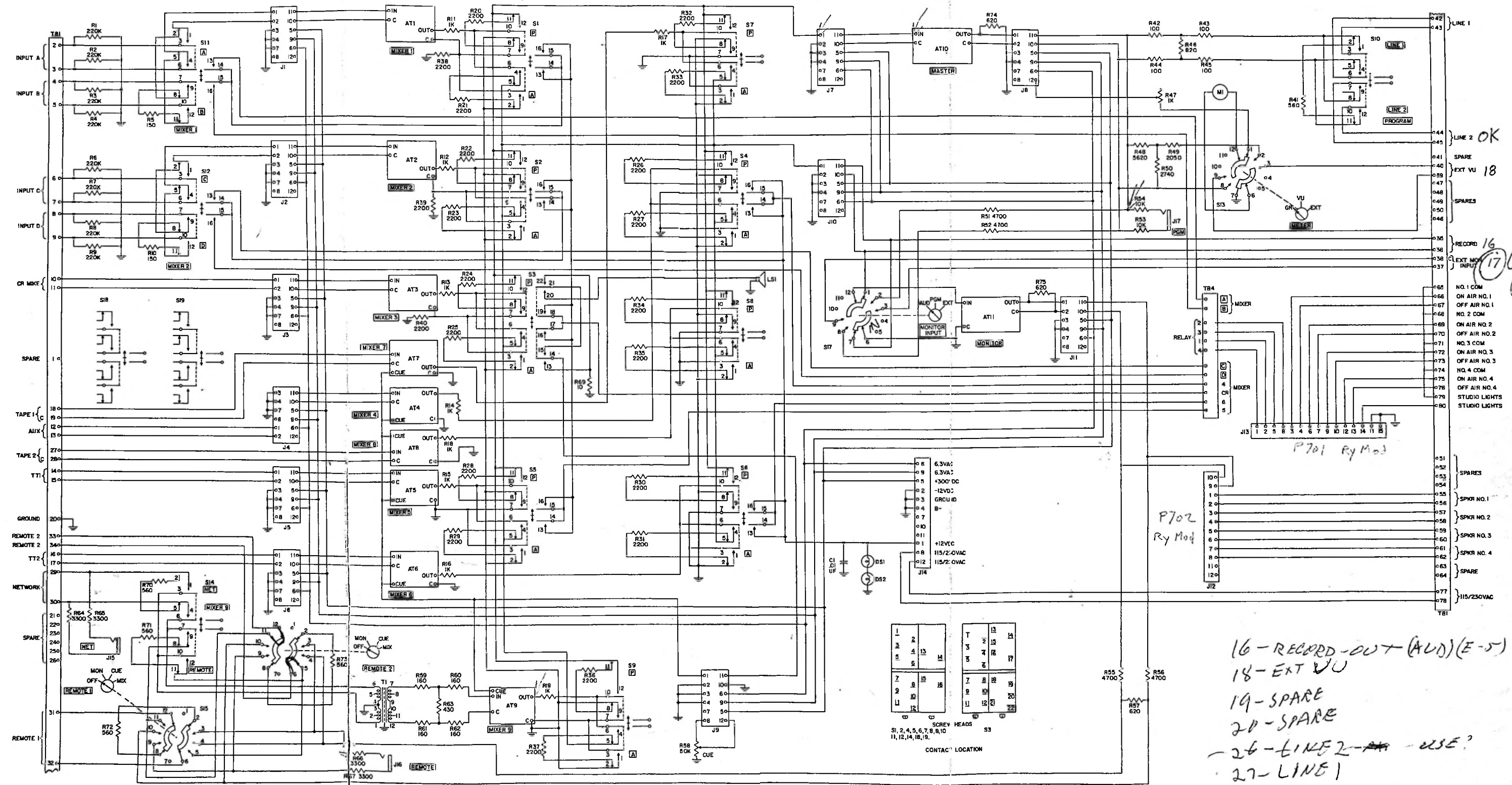

16-RECORD-OUT (AUD) (E-5)
 18-EXT VU
 19-SPARE
 20-SPARE
 26-LINE 2 - USE?
 27-LINE 1

Figure 7-1. Broadcast Console 212G-1, Schematic Diagram

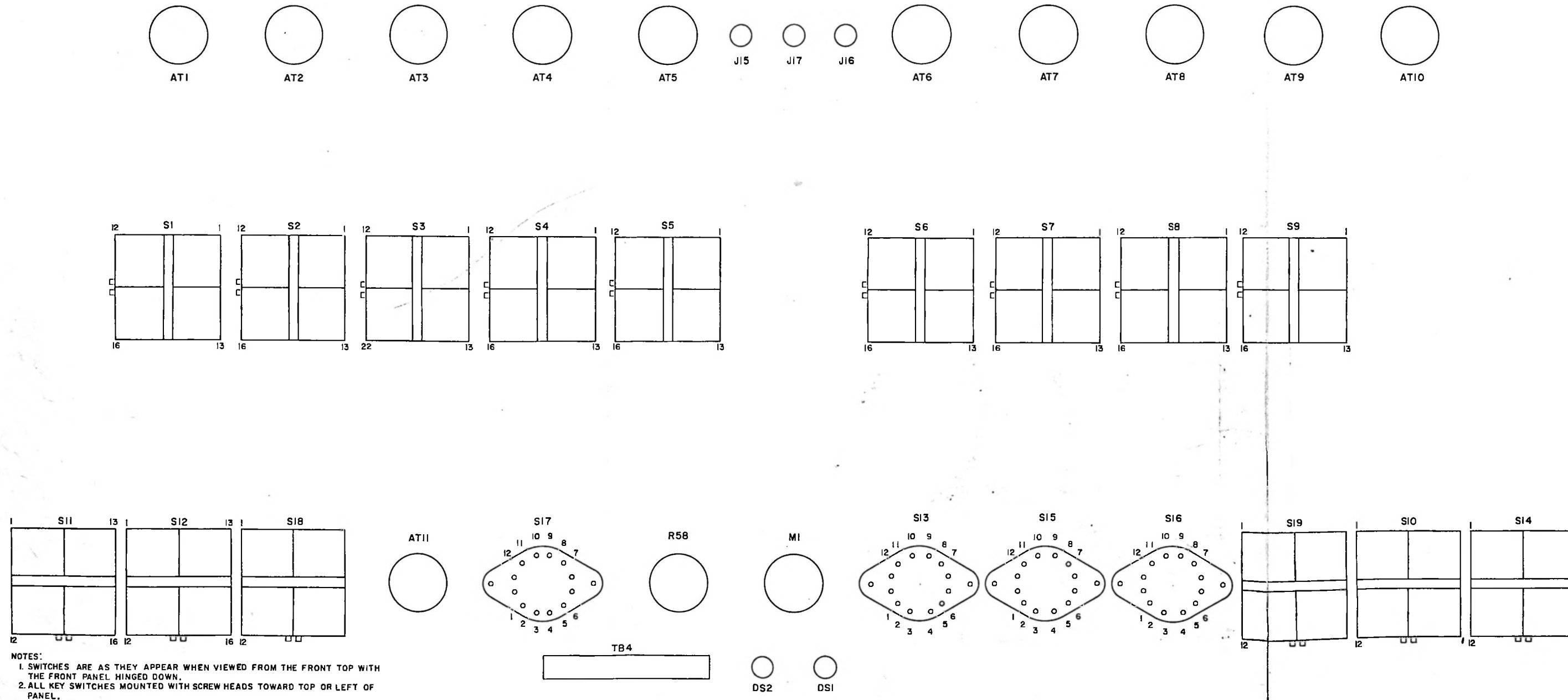

Figure 7-2. Broadcast Console 212G-1 Switch Pin Orientation

LINES
REMOTE 1 REMOTE 2

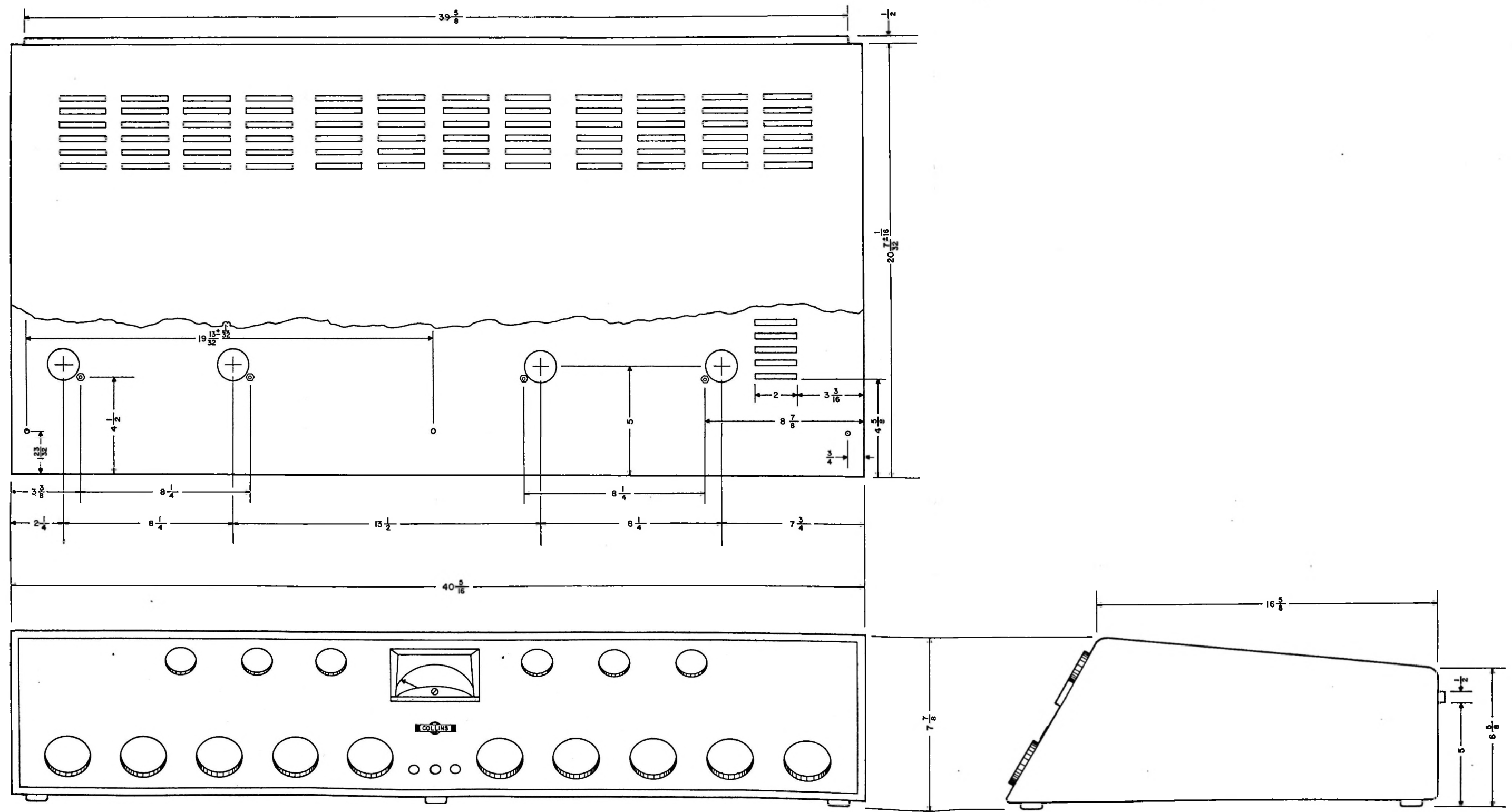

Figure 7-3. Broadcast Console 212G-1. Outline and Mounting Dimensions

PREAMPLIFIER 356A-1

© **COLLINS RADIO COMPANY**
1956, 1960

CEDAR RAPIDS, IOWA, U.S.A.

PRINTED IN THE UNITED STATES OF AMERICA

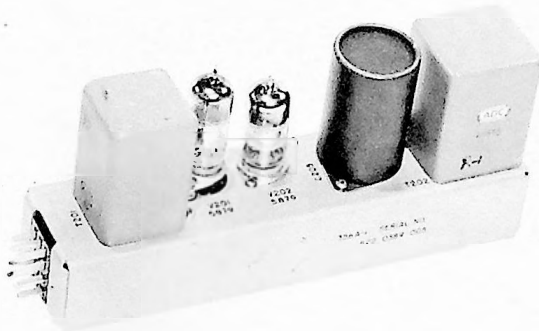

C99-40-P.

Figure 1. Preamplifier, 356A-1 Equipment Supplied

1.1 PURPOSE OF EQUIPMENT.

Preamplifier 356A-1 is intended for use as a pre-amplifier or booster with broadcast studio equipment such as Broadcast Console 212F-1 or 212G-1. It may be used in high-fidelity AM, FM, and TV broadcast service or program control in audio systems.

1.2 PHYSICAL DESCRIPTION.

Preamplifier 356A-1 (figure 1) is a plug-in module containing the necessary circuitry for two stages of amplification. The 356A-1 is 4-5/8 inches high,

2-1/8 inches wide, and 9-1/2 inches long and weighs approximately 2.5 pounds.

1.3 TUBE COMPLEMENT.

Function	Symbol	Tube Type
Input amplifier	V201	5879
Output amplifier	V202	5879

1.4 ELECTRICAL CHARACTERISTICS.

1.4.1 CONNECTORS. One 12-pin connector, P201, is located at the front end of the chassis. All connections to the 356A-1 are made at this connector.

1.4.2 POWER REQUIREMENTS. Power requirements for the 356A-1 are as follows: 250 - 300 volts d-c filtered at 6.5 - 7.5 ma and 6.3 volts a-c or d-c at 0.3 amperes.

1.4.3 FREQUENCY RANGE. The frequency range of the 356A-1 is 50 to 15,000 cycles per second.

1.4.4 INPUT IMPEDANCE. The 356A-1 is factory wired for 150 ohms unloaded transformer input impedance. Choice of 30, 150, 250, or 600 ohm impedance connections is available at the input transformer. See figure 4.

NOTE

If 250-ohm balanced input to the 356A-1 is desired, connect a 2700-ohm resistor from transformer T201 terminal 2 to ground and a 2700-ohm resistor from terminal 5 to ground. Disconnect the wire from terminal 4 and connect it to terminal 5. Disconnect terminal 3. If 30-ohm balanced input is desired, connect a 270-ohm resistor from terminal 4 to ground and connect a 270-ohm resistor from terminal 5 to ground. Disconnect the wire from terminal 2 and connect it to terminal 5. Disconnect terminal 3.

1.4.5 GAIN. When the 356A-1 is used in preamplifier service, a -60 dbm (nominal) input from a commercial microphone produces a -20 dbm output. When used as a booster with input connected for 600 ohms impedance, a -22 dbm input signal produces an output of +18 dbm which is maximum rated output power. Gain through the preamplifier is 40 db.

1.4.6 OUTPUT IMPEDANCE. The output of the 356A-1 may be connected for either 150 or 600 ohms output impedance (balanced or unbalanced). It is factory connected for 600 ohms output impedance. For information on terminal connection for 150 ohms output impedance, see figure 4, note 2.

1.4.7 FREQUENCY RESPONSE. The frequency response of the 356A-1 is ± 1 db from 50 to 15,000 cps at $\pm 0.5\%$ maximum distortion.

1.4.8 NOISE LEVEL. The equivalent input noise level of the preamplifier is -118 dbm. When the 356A-1 is used with Power Supply 409X-1 or 409X-2, the filaments are maintained at approximately +30 volts d-c above ground. This positive bias minimizes a-c noise in the preamplifier.

2.1 CIRCUIT DESCRIPTION.

Figure 4 is a schematic diagram of Preamplifier 356A-1. Input to the preamplifier is coupled by transformer T201 to the grid of V201. The input amplifier (V201) is a pentode-connected type 5879. Its output is resistance-capacitance coupled to the grid of a triode-connected type 5879 (V202). Output from V202 is taken from the secondary winding of transformer T202. A third winding of T202 supplies inverse feed-back voltage to the cathode of the input amplifier. All connections to the amplifier are made at P201.

3.1 MAINTENANCE.

Normal maintenance will consist of tube replacement. Table 1 gives voltage and resistance measurements for Preamplifier 356A-1.

4.1 TABLE OF REPLACEABLE PARTS.

Table 2 gives the description, circuit function, and Collins part number for all replaceable parts in the 356A-1. When replacement of parts is necessary, only parts identical or equivalent to those listed should be used. All parts above the chassis are identified in figure 2. All parts under the chassis are identified in figure 3.

TABLE 1. VOLTAGE AND RESISTANCE MEASUREMENTS FOR PREAMPLIFIER 356A-1

Conditions of Measurement:

- a. Voltage readings are taken with power applied as in normal operation.
- b. Line voltage 115 volts a-c. Plate supply voltage adjusted to +300 volts.
- c. Resistance readings are taken with no power applied.
- d. All measurements from terminal to ground.
- e. Voltage measurements made with a 20,000 ohms-per-volt meter.

TUBE		PIN NUMBER								
		1	2	3	4	5	6	7	8	9
V201 (5879)	V DC	0	0	1.9	20-50	20-50	0	46	82	1.9
	V AC	0	0	0	3.0	3.0	0	0	0	0
	Ohms	6K	0	2300	2800	2800	0	37K	200K	2300
V202 (5879)	V DC	0	0	5.7	40	40	0	210	210	210
	V AC	0	0	0	3.0	3.0	0	0	0	0
	Ohms	2.2 meg	0	900	2800	2800	0	40K	40K	40K

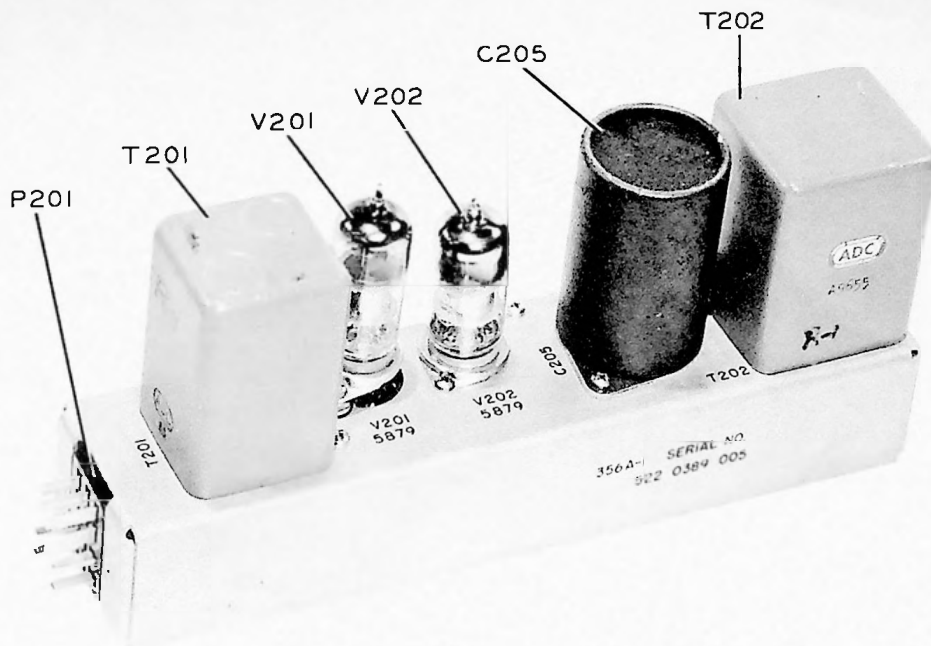

Figure 2. Preamplifier, 356A-1 Top View

C99-30-P.

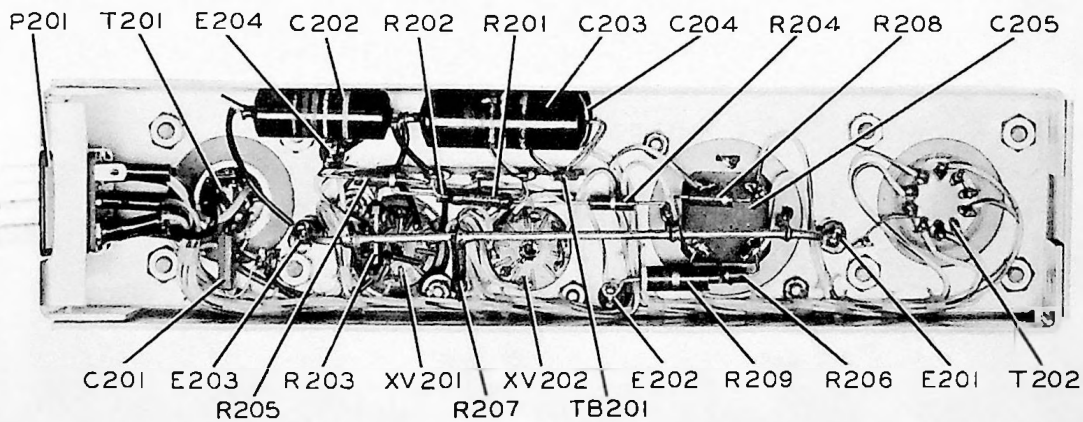

Figure 3. Preamplifier, 356A-1 Bottom View

C99-31-P.

PARTS LIST

ITEM	DESCRIPTION	COLLINS PART NUMBER
C201	NOT USED	
C202	CAPACITOR: paper, 0.047 uf $\pm 10\%$, 400 vdcw	931 0295 00
C203	CAPACITOR: paper, 0.1 uf $\pm 10\%$, 400 vdcw	931 0299 00
C204	Same as C203	931 0299 00
C205	CAPACITOR: dry electrolytic, quadruple section; sections 1 and 2, 20 uf, 450 vdcw $+250\%$ -10% tolerance; section 3 and 4, 50 uf, 50 vdcw $+250\%$ -10% tolerance	183 1260 00
E201	TERMINAL, stud: melamine body, brass term (tinned, brass base, cadmium plated; hex	306 0233 00
E202	Same as E201	306 0233 00
E203	Same as E201	306 0233 00
E204	TERMINAL, stud: melamine body, terminal brass hot tin dipped, base brass cadmium plated	306 0234 00
P201	CONNECTOR, plug: 12 rectangular male contacts	365 2120 00
R201	RESISTOR: comp, 0.16 megohms $\pm 5\%$, 1/2 w	745 1445 00
R202	RESISTOR: comp, 0.10 megohms $\pm 10\%$, 1/2 w	745 1436 00
R203	RESISTOR: comp, 51,000 ohms $\pm 5\%$, 1/2 w	745 1424 00
R204	RESISTOR: comp, 2.2 megohm $\pm 10\%$, 1/2 w	745 1492 00
R205	RESISTOR: comp, 5.6 megohm $\pm 10\%$, 1/2 w	745 1510 00
R206	RESISTOR: comp, 30,000 ohms $\pm 5\%$, 1/2 w	745 1413 00
R207	RESISTOR: comp, 910 ohms $\pm 5\%$, 1/2 w	745 1350 00
R208	RESISTOR: comp, 2,200 ohms $\pm 10\%$, 1/2 w	745 1366 00

ITEM	DESCRIPTION	COLLINS PART NUMBER
R209	RESISTOR: comp, 9100 ohms $\pm 5\%$, 1 w	745 3382 00
R210	RESISTOR: comp, 270 ohms $\pm 10\%$, 1/2 w (separate) in cloth bag	745 1328 00
R211	Same as R210	745 1328 00
R212	RESISTOR: comp, 2700 ohms $\pm 10\%$, 1/2 w (separate) in cloth bag	745 1370 00
R213	Same as R212	745 1370 00
T201	TRANSFORMER, AF: input type; 600 ohms; primary impedance CT; 340 ohms primary impedance, 150 ohms CT; 37 ohms primary impedance; secondary 50,000 ohms	667 0220 00
T202	TRANSFORMER, AF: output type; primary 16,500 ohms, 6 ma dc; secondary impedance 600 ohms when series connected; 150 ohms when parallel connected; transformer contains a feedback winding, shielded between primary and secondary; grounded	667 0221 00
TB201	BOARD, TERMINAL: phenolic PBG, 5 solder lug terminals	306 0550 00
V201	TUBE, electron: miscellaneous type, pentode 5879	257 0104 00
V202	Same as V201	257 0104 00
XV201	SOCKET, tube: 9 contact miniature	220 1274 00
XV202	SOCKET, tube: 9 contact miniature	220 1274 00

PROGRAM/MONITOR AMPLIFIER 356B-1

© COLLINS RADIO COMPANY
1956, 1960

CEDAR RAPIDS, IOWA, U.S.A.

PRINTED IN THE UNITED STATES OF AMERICA

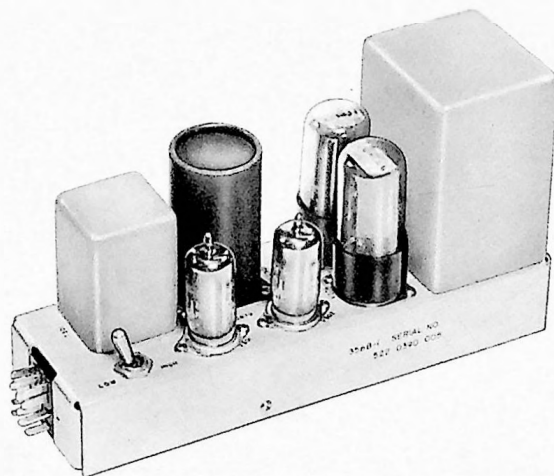

5342301
Figure 1. Program/Monitor Amplifier 356B-1,
Equipment Supplied

1.1 PURPOSE OF EQUIPMENT.

Program/Monitor Amplifier 356B-1 is intended for use as a program or monitor amplifier with broadcast studio equipment such as Broadcast Console 212F-1 or 212G-1. It may be used in high-fidelity AM, FM,

and TV broadcast service or program control in audio systems.

1.2 PHYSICAL DESCRIPTION.

Program/Monitor Amplifier 356B-1 (figure 1) is a plug-in module containing necessary circuitry for three stages of amplification. The 356B-1 is 5-3/4 inches high, 3-7/8 inches wide, and 9-1/2 inches long and weighs approximately 6 pounds.

1.3 TUBE COMPLEMENT.

<u>Function</u>	<u>Symbol</u>	<u>Tube Type</u>
Input amplifier	V301	5879
Phase inverter	V302	5879
Output amplifier	V303	6V6
Output amplifier	V304	6V6

1.4 ELECTRICAL CHARACTERISTICS.

1.4.1 CONNECTORS. One 12-pin connector, P301, is located at the front end of the chassis. All connections to the 356B-1 are made at this connector.

1.4.2 POWER REQUIREMENTS. Power requirements for the 356B-1 are as follows: 250 - 300 volts

d-c at 63 - 88 ma and 6.3 volts a-c or d-c at 1.2 amperes.

1.4.3 FREQUENCY RANGE. The frequency range of the 356B-1 is 50 to 15,000 cycles per second.

1.4.4 INPUT IMPEDANCE. The 356B-1 is factory wired for 600 ohms unloaded transformer input impedance. It may be rewired for 150 ohms input impedance if desired. See figure 4.

1.4.5 GAIN. When the HI-LOW gain switch on the top of the amplifier chassis is in the HI position the amplifier has 68-db gain. When the gain switch is in the LOW position, the gain is 56 db.

1.4.6 OUTPUT IMPEDANCE. The 356B-1 is factory wired for 600 ohms output impedance. It may be rewired for 150 ohms output impedance. See figure 4.

1.4.7 FREQUENCY RESPONSE. The frequency response of the 356B-1 is ± 1 db from 50 to 15,000 cps.

1.4.8 DISTORTION. The distortion in the output of the 356B-1 is 0.5% maximum at +30 dbm (one watt) output and 3% maximum at +39 dbm (8 watts) output.

1.4.9 NOISE LEVEL. The equivalent input noise level of the amplifier is -116 dbm.

2.1 CIRCUIT DESCRIPTION.

Figure 4 is a schematic diagram of Program/Monitor Amplifier 356B-1. Input signal is coupled by transformer T301 to the grid of the input amplifier V301. The input amplifier is a pentode-connected type 5879. Its output is resistance-capacitance coupled to the phase inverter V302. The phase inverter is a triode-connected type 5879. Output from the phase inverter is RC coupled to the grids of two type 6V6 tubes (V303 and V304) in push-pull. Output from the amplifier is coupled to the load by transformer T302. Inverse feedback is taken from a third winding of T302 and applied to the cathode of V301.

3.1 MAINTENANCE.

Normal maintenance will consist of tube replacement. Table 1 gives voltage and resistance measurements for Program/Monitor Amplifier 356B-1. If excessive distortion occurs, replace V303 and V304.

4.1 TABLE OF REPLACEABLE PARTS.

Table 2 gives the description, circuit function, and Collins part number for all replaceable parts in Program/Monitor Amplifier 356B-1. When replacement of parts is necessary, only parts identical or equivalent to those listed should be used. All parts on top of the chassis are identified in figure 2. All parts mounted beneath the chassis are identified in figure 3.

TABLE 1. VOLTAGE AND RESISTANCE MEASUREMENTS FOR THE 356B-1 PROGRAM/MONITOR AMPLIFIER

Conditions of measurement:

- a. Voltage readings are taken with a 20,000 ohms-per-volt meter.
- b. Line voltage 115 v a-c. Plate voltage adjusted to +300 volts.
- c. Resistance readings taken with no power applied.
- d. All measurements from terminal to ground.

TUBE		PIN NUMBER								
		1	2	3	4	5	6	7	8	9
V301 (5879)	V DC	0	0	1.4	20-50	20-50	0	54	141	1.4
	V AC	0	0	0	3.0	3.0	0	0	0	0
	Ohms	6K	0	1400	2800	2800	0	27K	120K	1400
V302 (5879)	V DC	24	0	50	20-50	20-50	0	170	170	170
	V AC	0	0	0	3.0	3.0	0	0	0	0
	Ohms	1 meg	0	23K	2800	2800	0	55K	55K	55K
V303 (6V6)	V DC	0	20-50	290	300	0	0	20-50	18	
	V AC	0	3.0	0	0	0	0	3.0	0	
	Ohms	0	2800	24K	23K	560K	Inf	2800	470	
V304 (6V6)	V DC	0	20-50	290	300	0	0	20-50	18	
	V AC	0	3.0	0	0	0	0	3.0	0	
	Ohms	0	2800	24K	23K	560K	Inf	2800	470	

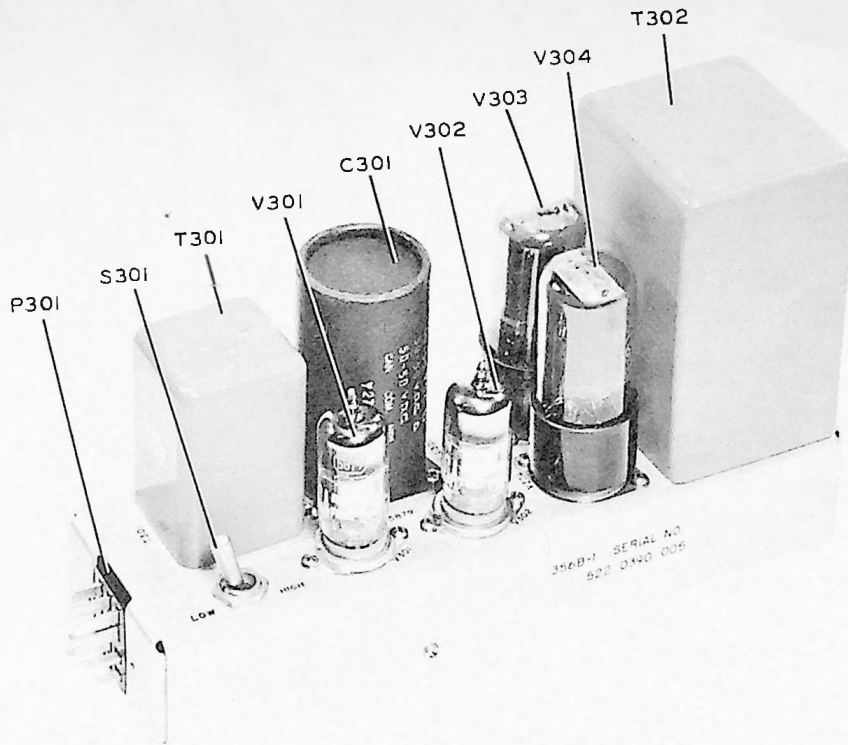

Figure 2. Program/Monitor, Amplifier, 356B-1, Top View

C99-32-P.

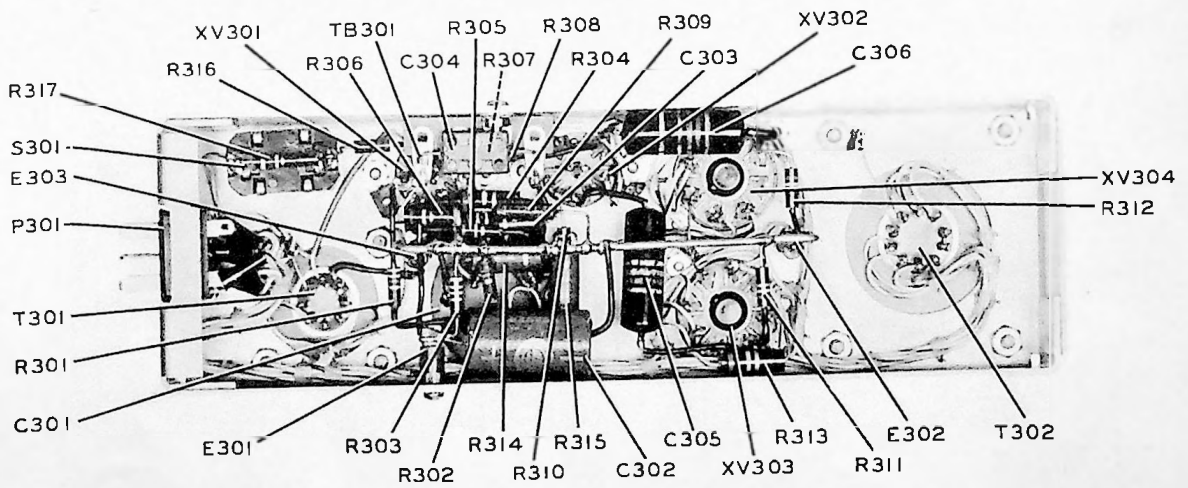

Figure 3. Program/Monitor Amplifier, 356B-1, Bottom View

C99-33-P.

PARTS LIST

ITEM	DESCRIPTION	COLLINS PART NUMBER
C301, C301A, C301B, C301C, C301D C302	CAPACITOR: dry electrolytic, quadruple sections, section No. 1, 40 uf, 450 V dc, section No. 2, 50 uf 50 V dc, section No. 3, 50 uf, 50 V dc, section No. 4, 50 uf V dc capacity tolerance -10% +250% each section CAPACITOR: electrolytic, 4 uf -15% +100%, 250 vdcw	183 1261 00 183 1209 00
C303	CAPACITOR: paper, 0.047 uf +10%, 400 vdcw	931 0295 00
C304	CAPACITOR: mica, 82 uuf +10%, 500 vdcw	935 0170 00
C305	SAME as C303	931 0295 00
C306	SAME as C303	931 0295 00
E301	TERMINAL: stud, melamine body, brass term tinned, brass base, cadmium plated, hex	306 0233 00
E302	TERMINAL: stud, melamine body, terminal, brass hot tin dipped, base brass, cadmium plated, hex	306 0234 00
E303	SAME as E302	306 0234 00
P301	CONNECTOR: plug, 12 rectangular male contacts	365 2120 00
R301	RESISTOR: comp, 330 ohms ±10%, 1/2 w	745 1331 00
R302	RESISTOR: comp, 1100 ohms ±5%, 1/2 w	745 1354 00
R303	RESISTOR: comp, 33,000 ohms ±10%, 1/2 w	745 1415 00
R304	RESISTOR: comp, 0.10 megohm ±10%, 1/2 w	745 1436 00
R305	RESISTOR: comp, 0.10 megohm ±10%, 1 w	745 3436 00
R306	RESISTOR: comp, 0.20 megohm ±5%, 1/2 w	745 1448 00
R307	RESISTOR: comp, 1.0 megohm ±10%, 1/2 w	745 1478 00
R308	RESISTOR: comp, 2000 ohms ±5%, 1/2 w	745 1364 00
R309	RESISTOR: comp, 22,000 ohms ±5%, 1/2 w	745 1407 00
R310	RESISTOR: comp, 24,000 ohms ±5%, 1/2 w	745 1410 00
R311	RESISTOR: comp, 0.56 megohm ±10%, 1/2 w	745 1468 00

ITEM	DESCRIPTION	COLLINS PART NUMBER
R312	SAME as R311	745 1468 00
R313	RESISTOR: comp, 15,000 ohms ±10%, 1 w	745 3401 00
R314	RESISTOR: comp, 510 ohms ±5%, 2 w	745 5640 00
R315	SAME as R314	745 5640 00
R316	RESISTOR: comp, 9,100 ohms ±5%, 1/2 w	745 1392 00
R317	RESISTOR: comp, 91,000 ohms ±5%, 1/2 w	745 1434 00
S301	SWITCH: toggle, spat, 30 V dc 20 amps in locking position	266 3072 00
T301	TRANSFORMER AF: input type, 600 ohms primary impedance CT; 340 ohms primary impedance, 150 ohms CT; 37 ohms primary impedance; secondary 50,000 ohms	667 0220 00
T302	TRANSFORMER, AF: output type; primary 9,000 ohms, secondary impedance 600 ohms when series connected; 150 ohms when parallel connected; transformer contains a feedback winding shielded between primary and secondary, grounded	667 0222 00
TB301	BOARD, TERMINAL: component mtg; four solder lug terminals; terminals 3/8 in. between centers; brown bakelite board	306 2230 00
V301	TUBE: electron, pentode, 5879	257 0104 00
V302	SAME as V301	257 0104 00
V303	TUBE: electron, tetrode amplifier, 6Y6GT	255 0021 00
V304	SAME as V303	255 0021 00
XV301	SOCKET: tube, 9 miniature contacts	220 1274 00
XV302	SAME as XV301	220 1274 00
XV303	SOCKET: tube, 8 prong octal	220 1005 00
XV304	SAME as XV303	220 1005 00

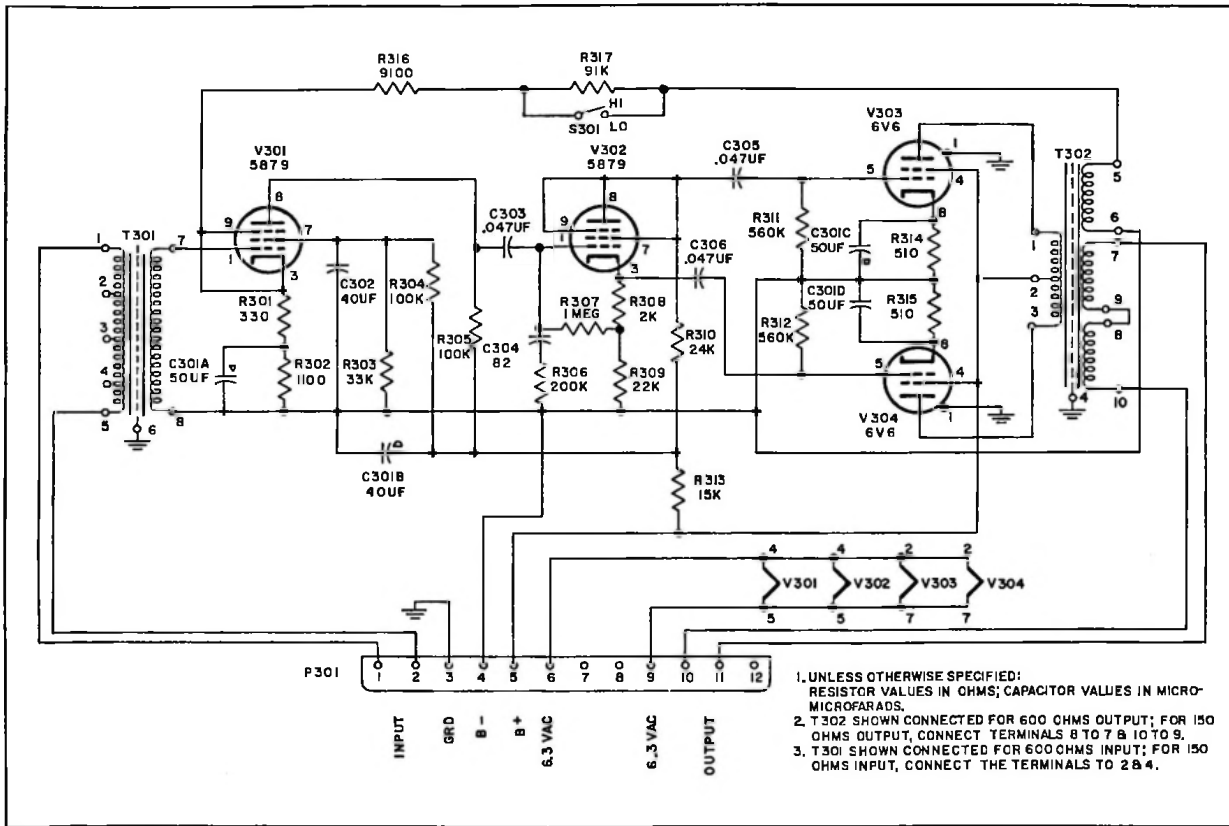

Figure 4. Program/Monitor Amplifier, 356B-1, Schematic Diagram

C99-09-3

LIMITER AMPLIFIER 356E-1

© **COLLINS RADIO COMPANY**
1956, 1960

CEDAR RAPIDS, IOWA, U.S.A.

PRINTED IN THE UNITED STATES OF AMERICA



C99-23-P.

Figure 1. Limiter Amplifier, 356E-1,
Equipment Supplied

1.1 PURPOSE OF EQUIPMENT.

Limiter Amplifier 356E-1 is an automatic average level or peak-limiting amplifier for broadcast, TV, and microwave audio systems.

1.2 PHYSICAL DESCRIPTION.

Limiter Amplifier 356A-1 (figure 1) is a plug-in module containing two stages of amplification with a

bias rectifier. It is 5-5/16 inches high, 3 inches wide, and 9-1/2 inches long and weighs 4.75 pounds.

1.3 TUBE COMPLEMENT.

Function	Symbol	Tube Type
Input amplifier	V601	6L6386
Output amplifier	V602	6V6
Output amplifier	V603	6V6
Bias rectifier	V604	6AL5

1.4 ELECTRICAL CHARACTERISTICS.

1.4.1 CONNECTORS. One 12-pin connector, P601, is located at the front end of the chassis. All connections for input, output, and power are made at this connector. Two jacks, J601 and J602, are provided at the front corners of the chassis top for measurement of threshold voltage.

1.4.2 POWER REQUIREMENTS. Power requirements for the 356E-1 are as follows: 300 volts d-c at 77 milliamperes and 6.3 volts a-c at 1.55 amperes.

1.4.3 FREQUENCY RANGE. The frequency range of the 356E-1 is 50 to 15,000 cycles per second.

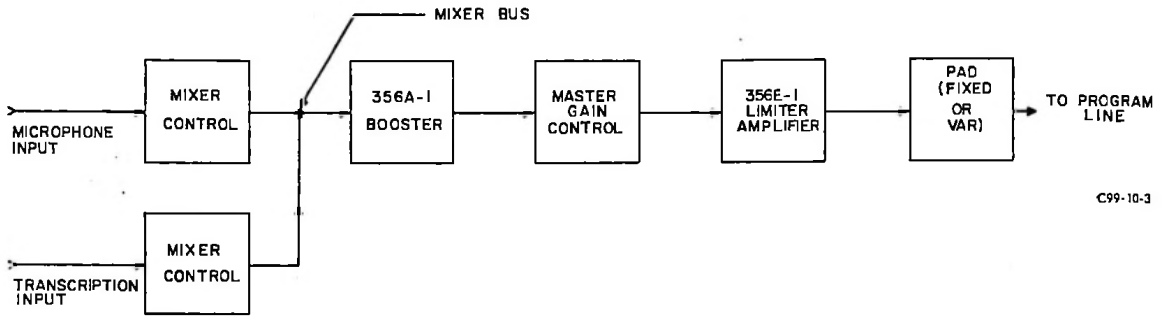

C99-10-3

Figure 2. Collins Type 356E-1 Limiter Amplifier as Automatic Fader Control, Suggested Arrangement

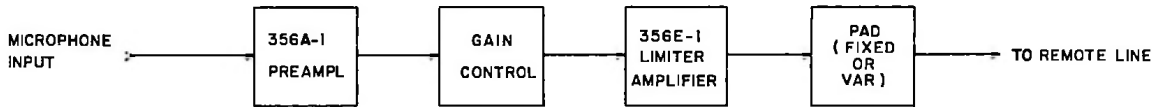

A. 356E-1 LIMITER AMPLIFIER LOCATED REMOTELY

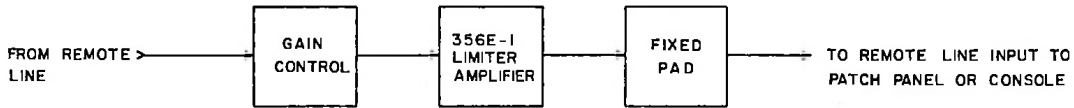

B. 356E-1 LIMITER AMPLIFIER FED FROM REMOTE LINE

C99-13-3

Figure 3. Collins Type 356E-1 Limiter Amplifier as Automatic Level Control, Suggested Arrangement

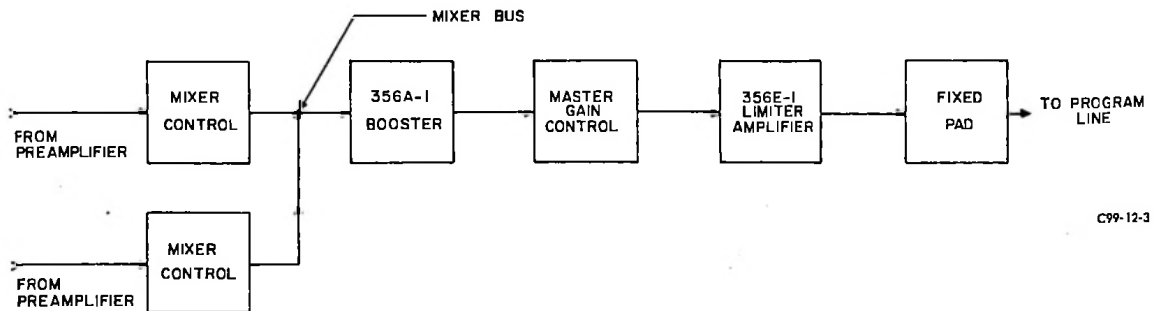

C99-12-3

Figure 4. Collins Type 356E-1 Limiter Amplifier as Automatic Mixer, Suggested Arrangement

1.4.4 INPUT IMPEDANCE. Limiter Amplifier 356E-1 is factory wired for 600 ohms unloaded transformer input impedance. It may be rewired for 150 ohms input impedance if desired. See figure 11.

1.4.5 GAIN. The gain of the 356E-1 is 54 db.

1.4.6 OUTPUT IMPEDANCE. The 356E-1 is factory wired for 600 ohms output impedance. It may be rewired for 150 ohms output impedance if desired. See figure 11.

1.4.7 FREQUENCY RESPONSE. The frequency response of the 356E-1 is ± 1 db from 50 to 15,000 cps.

1.4.8 DISTORTION. The distortion of the 356E-1 is as follows: 1.5% maximum distortion from 50 to 15,000 cps with no compression and 2% maximum distortion from 50 to 15,000 cps at any level up to 30 db gain reduction (with threshold set at +20 dbm output).

1.4.9 NOISE LEVEL. The noise level in the output of the 356E-1 is -50 dbm with threshold control set for +20 dbm output.

1.4.10 COMPRESSION RATIO. The compression ratio of the 356E-1 is adjustable from a ratio of 1.6/1 to a ratio of 5/1. A ratio of 3/1 is optimum over a 30-db range of input levels.

1.4.11 ATTACK TIME. The attack time of the 356E-1 is 11 milliseconds with the switch set in DUAL position or 62 milliseconds with the switch set in AVERAGE position.

1.4.12 RELEASE TIME. The release time of Limiter Amplifier 356E-1 is 0.9 seconds for 63% recovery with the switch set in the DUAL position, or 5.2 seconds for 63% recovery with the switch set in the AVERAGE position.

2.1 CIRCUIT DESCRIPTION.

Figure 11 is a schematic diagram of Limiter Amplifier 356E-1. Transformer T601 couples input signal to the grids of the push-pull input stage V601. Output from V601 is coupled to the grids of the push-pull output stage by C602 and C603. The output stage is transformer coupled to the load by T602. The threshold voltage control (R612) adjusts the positive bias applied to the cathodes of the bias rectifier V604. A sample of the output signal from the plates of V602 and V603 is coupled to the bias rectifier cathodes by C605 and C606. When the audio voltage at the plates of the output stage is high enough to overcome the threshold voltage, the bias rectifier V604 conducts. Plate current for V604 develops a negative voltage across R616. This negative voltage is the control voltage for the automatic gain circuit. It is applied to the grid return of the input amplifier V601. An increase in level of the input signal does not produce any limiting action until the threshold voltage is exceeded. When this happens, the gain of the input stage is reduced and the output level remains comparatively constant. When

the signal level at the input is again reduced below the threshold voltage, the bias rectifier V604 stops conducting and the bias of the input stage falls back to normal. Attack and release times of the amplifier are determined by the RC time constants in the plate circuit of V604. When S601 is in DUAL position, C607 is charged by the voltage across R616 and the attack time of the amplifier is determined by the time constant of R615 and C607. When the switch, S601, is in the same position and V604 stops conducting, the release time of the circuit is the time necessary for C607 to discharge through R616. When S601 is in AVERAGE position, R617 is shorted out. This connects C608 in parallel with C607 and the attack time is determined by the RC time constant of R615 and the sum of the capacities of C607 and C608. When V604 stops conducting, the release time of the circuit is the time necessary for C607 and C608 to discharge through R616.

2.2 APPLICATION.

2.2.1 GENERAL. The 356E-1 may be used as an automatic fader control, as an automatic level control in unattended remote operation, as an automatic mixer, or as a level control in microwave relay systems. Arrangements and adjustments for these uses are described in the following paragraphs.

2.2.2 THE 356E-1 USED AS AUTOMATIC FADER CONTROL. Refer to figure 2. The 356E-1 is plugged into J108 of the 212F-1 Broadcast Console. Operate the switch on the 356E-1 to DUAL position. Adjust the mixer in the transcription channel until the GR meter indicates a 2 to 5 db gain reduction. Adjust the mixer in the microphone channel until the microphone signal at the mixer bus is 20 db higher than the transcription signal at the same point. The use of the microphone channel automatically causes the transcription signal to drop 20 db below the microphone signal with an overall output increase of less than 7 db. This 7-db increase may be handled by the peak-limiting amplifier usually employed at the transmitter.

With this type of operation, announcements may be made over the transcription signal without adjustment of the mixers in the microphone or transcription channels. When an announcement is over, the transcription signal automatically returns to its original level.

2.2.3 THE 356E-1 USED AS AUTOMATIC LEVEL CONTROL IN UNATTENDED REMOTE OPERATION. Figure 3A shows a suggested arrangement for using Limiter Amplifier 356E-1 at a remote location. Figure 3B shows a suggested arrangement for using the 356E-1 at a studio with input from a remote line.

With an average input signal, adjust the input to the 356E-1 to produce approximately 15-db gain reduction.

2.2.4 THE 356E-1 USED AS AUTOMATIC MIXER. Figure 4 shows a suggested arrangement for using the 356E-1 as an automatic mixer. When two signals are present at the mixer bus, the amplifier acts as a master gain control, expander-compressor, or as a straight program amplifier.

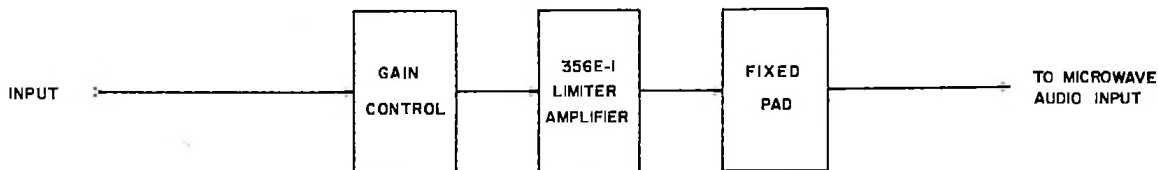

C99-11-3

Figure 5. Collins Type 356E-1 Limiter Amplifier as Automatic Level Control in Microwave Relay Systems, Suggested Arrangement

2.2.5 THE 356E-1 USED IN MICROWAVE RELAY SYSTEM. Figure 5 shows a suggested arrangement for using the 356E-1 to minimize audio level variations in a microwave relay system.

2.3 ADJUSTMENTS OR MODIFICATIONS.

2.3.1 GENERAL. The following paragraphs describe adjustments of threshold voltage for various input and output levels, modification of resistor values for various release times, and modification of meter and switching circuits to provide for monitoring the amount of gain reduction.

2.3.2 THRESHOLD VOLTAGE SETTINGS. Table 1 gives threshold voltage settings for various input and output levels. Optimum operation results when the threshold voltage is set at 23.5 volts for an output level of +20 dbm. If this level is too high, a fixed pad may be inserted in the output line. For selection of resistor values for selected values of attenuation, refer to figure 6.

TABLE 1. THRESHOLD VOLTAGE SETTINGS

Input DBM	Output DBM	Threshold Voltage
-44	+10	7.5
-40	+14	12.0
-36	+18	19.5
*-34	*+20	*23.5
-32	+22	29.0
-28	+26	45.0
-24	+30	69.0
*Optimum		

2.3.3 RELEASE TIME. The release time of the 356E-1 is satisfactory for most applications. If some other

LOSS IN DB	R1 IN OHMS	R2 IN OHMS	R1 IN OHMS	R2 IN OHMS
0	0	OPEN	0	OPEN
3	103	1703	51.3	1703
6	199	803	98	803
10	312	422	156	422
15	419	220	209	220
20	490	121	245	121

C99-18-3

Figure 6. Resistor Values for 600-Ohm Fixed Pads

value of release time is desired, change the values of R616 and R617. Table 2 gives other values of resistance for R616 and R617 with corresponding release times.

TABLE 2. VALUES OF R616 AND R617 AND CORRESPONDING RELEASE TIMES

Megohms		DUAL Position Seconds		AVERAGE Position Seconds
R616	R617	FAST	SLOW	
2.2	10	0.48	12.2	2.7
3.3	3.3	0.73	6.6	4.0
3.3	10	0.73	13.3	4.0
4.3	4.3	0.95	8.6	5.3
4.3	10	0.95	14.3	5.3
5.1	10	1.1	15.1	6.2
6.2	10	1.4	18.2	7.6

2.3.4 MODIFICATION OF VU METER AND SWITCHING CIRCUITS TO READ GAIN REDUCTION.

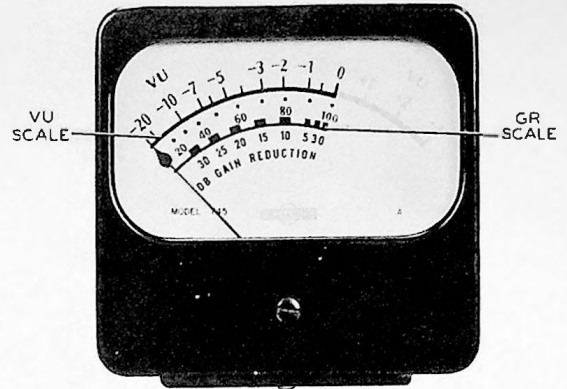

C99-26-P.

Figure 7. Vu Meter With GR Scale Decal Applied

Procedures for application of the GR-scale decal (supplied with the 356E-1) and for modification of switching circuits are outlined in the following steps:

- a. Remove the front of the vu meter.
- b. Prepare the decal for application according to printed instructions on the decal.

TABLE 3. VOLTAGE AND RESISTANCE MEASUREMENTS FOR THE 356E-1 LIMITER AMPLIFIER

Conditions of measurements:

- a. Voltage readings are taken with a 20,000 ohms-per-volt meter.
- b. Line voltage 115 v a-c. Plate voltage adjusted to +300 volts d-c.
- c. Resistance readings taken with no power applied and amplifier disconnected from power supply.
- d. All measurements from terminal to B-.

Tube		Pin Number								
		1	2	3	4	5	6	7	8	9
V601 (6386)	V DC	20-50	1.2	-0.2	67	0	67	-0.2	1.2	20-50
	V AC	3.0	0	0	0	0	0	0	0	3.0
	Ohms	Inf	200	3.8 meg	300K	Inf	55K	3.8 meg	200	Inf
V602 (6V6)	V DC	0	20-50	290	300	0	0	20-50	18	
	V AC	0	3.0	0	0	0	0	3.0	0	
	Ohms	Inf	Inf	300K	300K	510K	Inf	Inf	230	
V603 (6V6)	V DC	0	20-50	290	300	0	0	20-50	18	
	V AC	0	3.0	0	0	0	0	3.0	0	
	Ohms	Inf	Inf	300K	300K	510K	Inf	Inf	230	
V604 (6AL5)	V DC	0	0	20-50	20-50	0	0	0		
	V AC	0	0	3.0	3.0	0	0	0		
	Ohms	510K	3.8 meg	Inf	Inf	510K	Inf	3.8 meg		

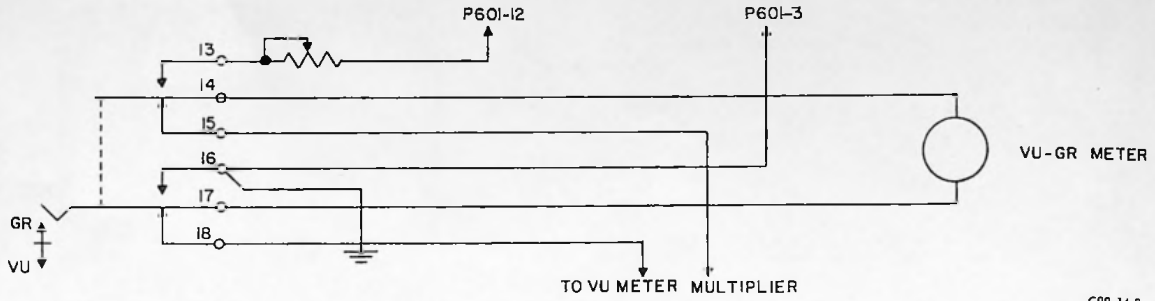

Figure 8. Vu Meter and GR Switch Connections, Schematic Diagram

c. Apply the decal to the VU meter scale with the plain black line of the decal directly over the black line on the meter scale and with the zero of the decal aligned with the zero of the meter scale. See figure 7.

d. Replace the front of the VU meter.

e. If VU-GR switching is desired, refer to figure 8 for wiring connections.

3.1 MAINTENANCE.

Normal maintenance will consist of tube replacement. When replacing V602 and V603, adjust R618 for minimum distortion at 50 cps. As these tubes age, this adjustment may again be made. If excessive distortion

occurs, replace V602 and V603. Table 3 gives voltage and resistance measurements for Limiter Amplifier 356E-1.

4.1 TABLE OF REPLACEABLE PARTS.

Table 4 gives the description, circuit function, and Collins part number for all replaceable parts in Limiter Amplifier 356E-1. When replacement of parts is necessary, only parts identical or equivalent to those listed should be used. All parts on top of the chassis are identified in figure 9. All parts mounted beneath the chassis are identified in figure 10.

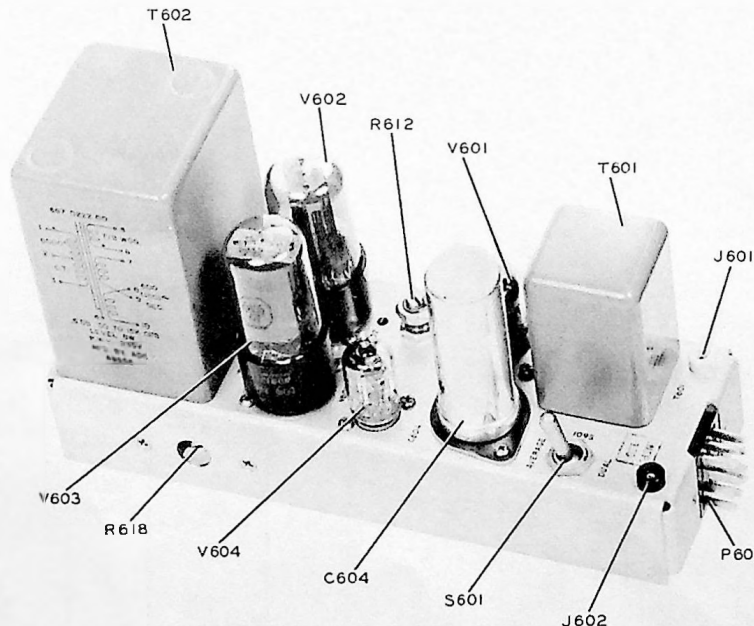

Figure 9. Limiter Amplifier, 356E-1 Top View

TABLE 4. TABLE OF REPLACEABLE PARTS FOR LIMITER AMPLIFIER 356E-1

ITEM	CIRCUIT FUNCTION	DESCRIPTION	COLLINS PART NUMBER
C601	Frequency compensation	CAPACITOR: paper, 0.001 uf $\pm 10\%$, 400 vdcw	931 0277 00
C602	Coupling	CAPACITOR: paper, 0.1 uf $\pm 10\%$, 400 vdcw	931 0299 00
C603	Coupling	SAME as C-602	931 0299 00
C604	Decoupling	CAPACITOR: electrolytic; dual section; 20 uf -10% +50%, 450 vdcw each section	183 1262 00
C605	Coupling	SAME as C602	931 0299 00
C606	Coupling	SAME as C602	931 0299 00
C607	Part of attack-and-release time circuit	CAPACITOR: paper, 0.22 uf $\pm 10\%$, 400 vdcw	931 0303 00
C608	Part of attack-and-release time circuit	CAPACITOR: paper, 1.00 uf $\pm 20\%$, 200 vdcw	931 0908 00
E601	Tie point	TERMINAL, stud: melamine body, terminal, brass hot tin tipped, base brass, cadmium plated; hex	306 0234 00
E602	Tie point	SAME as E601	306 0234 00
J601	Pin jack	JACK, TIP: small phone tip, insulated w/ yellow low-loss nylon; nonprecious contact w/ precious metal finish; solder wire attachment	360 0066 00
J602	Pin jack	CONNECTOR, receptacle: 1 round female contact; straight type	360 0063 00
P601	Connector	CONNECTOR, plug: 12 rectangular male contacts	365 2120 00
R601	Frequency compensation	RESISTOR: comp, 0.33 megohm $\pm 5\%$, 1/2 w	745 1456 00
R602	Cathode bias for V601A	RESISTOR: comp, 130 ohms $\pm 5\%$, 1/2 w	745 1315 00
R603	Cathode bias for V601B	SAME as R602	745 1315 00
R604	Cathode bias for V601	RESISTOR: comp, 68 ohm $\pm 5\%$, 1/2 w	745 1302 00
R605	Plate load for V601A	RESISTOR: comp, 10,000 ohms $\pm 5\%$, 1/2 w	745 1393 00
R606	Plate load for V601B	SAME as R605	745 1393 00
R607	Decoupling	RESISTOR: wire wound, 20,000 ohms $\pm 5\%$, 5 w	747 9796 00
R608	Grid load for V602	RESISTOR: comp, 0.51 megohm $\pm 5\%$, 1/2 w	745 1466 00
R609	Cathode bias	RESISTOR: comp, 180 ohm $\pm 10\%$, 2 w	745 5621 00
R610	Grid load for V603	SAME as R608	745 1466 00
R611	Voltage-dropping	RESISTOR: comp, 0.20 megohm $\pm 5\%$, 1/2 w	745 1448 00
R612	Threshold voltage adjust	RESISTOR: variable; comp, 100,000 ohms $\pm 20\%$, 2 w at 70°C	380 5766 00
R613	Diode bias	SAME as R608	745 1466 00

TABLE 4. TABLE OF REPLACEABLE PARTS FOR LIMITER AMPLIFIER 356E-1 (Cont)

ITEM	CIRCUIT FUNCTION	DESCRIPTION	COLLINS PART NUMBER
R614	Diode bias	SAME as R608	745 1466 00
R615	Part of attack-and-release time circuit	RESISTOR: comp, 51,000 ohms $\pm 5\%$, 1/2 w	745 1424 00
R616	Part of attack-and-release time circuit	RESISTOR: comp, 4.3 megohm $\pm 5\%$, 1/2 w	745 1504 00
R617	Part of attack-and-release time circuit	RESISTOR: 10 megohm $\pm 5\%$, 1/2 w	745 1519 00
R618	V602, V603 cathode balance	RESISTOR: variable; 100 ohms $\pm 10\%$ WW A linear; 2 watts	750 0516 00
S601	Selects Dual or AVERAGE limiting	SWITCH, toggle: spst, 30 V dc, 20 amps in locking position, phenolic body	266 3072 00
T601	Input transformer	TRANSFORMER, AF: input type; 1000 cps, 1 milliwatt; primary 600 ohm, tap No. 1, 150 ohms, connected CT, tap No. 2, 150 ohms, 500 rms; secondary 60,000 ohms connected CT, 500 rms	667 0211 00
T602	Output transformer	TRANSFORMER, AF: output type; primary 9000 ohms, secondary impedance 600 ohms when series connected; 150 ohm when parallel connected; transformer contains a feedback winding shielded between primary and secondary grounded	667 0222 00
TB601		BOARD, TERMINAL: phenolic, 3 solid lug terminals, brass terminals	306 9033 00
TB602		SAME as TB601	306 9033 00
TB603		SAME as TB601	306 9033 00
TE604		SAME as TB601	306 9033 00
V601	Input amplifier	TUBE, electron: vacuum tube, 6386	253 0015 00
V602	Output amplifier	TUBE, electron: receiving tube beam, 6V6 GT	255 0021 00
V603	Output amplifier	SAME as V602	255 0021 00
V604	Diode limiter	TUBE, electron: twin diode rectifier 6AL5	257 0018 00
XV601		SOCKET, tube: 9 contact miniature	220 1262 00
XV602		SOCKET, tube: 8 prong octal	220 1005 00
XV603		SAME as XV602	220 1005 00
XV604		SOCKET TUBE: 7 contact miniature	220 1235 00

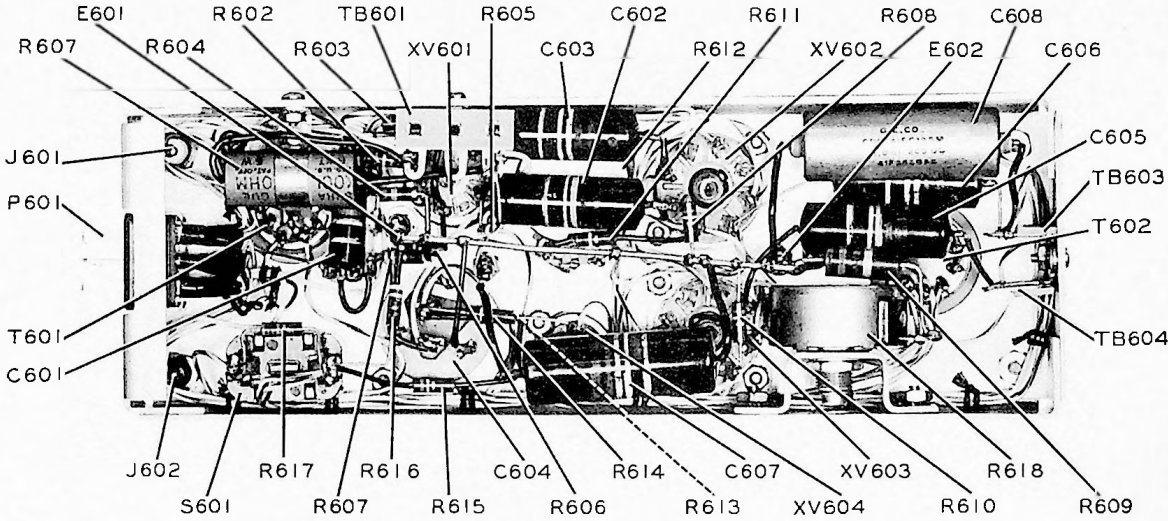
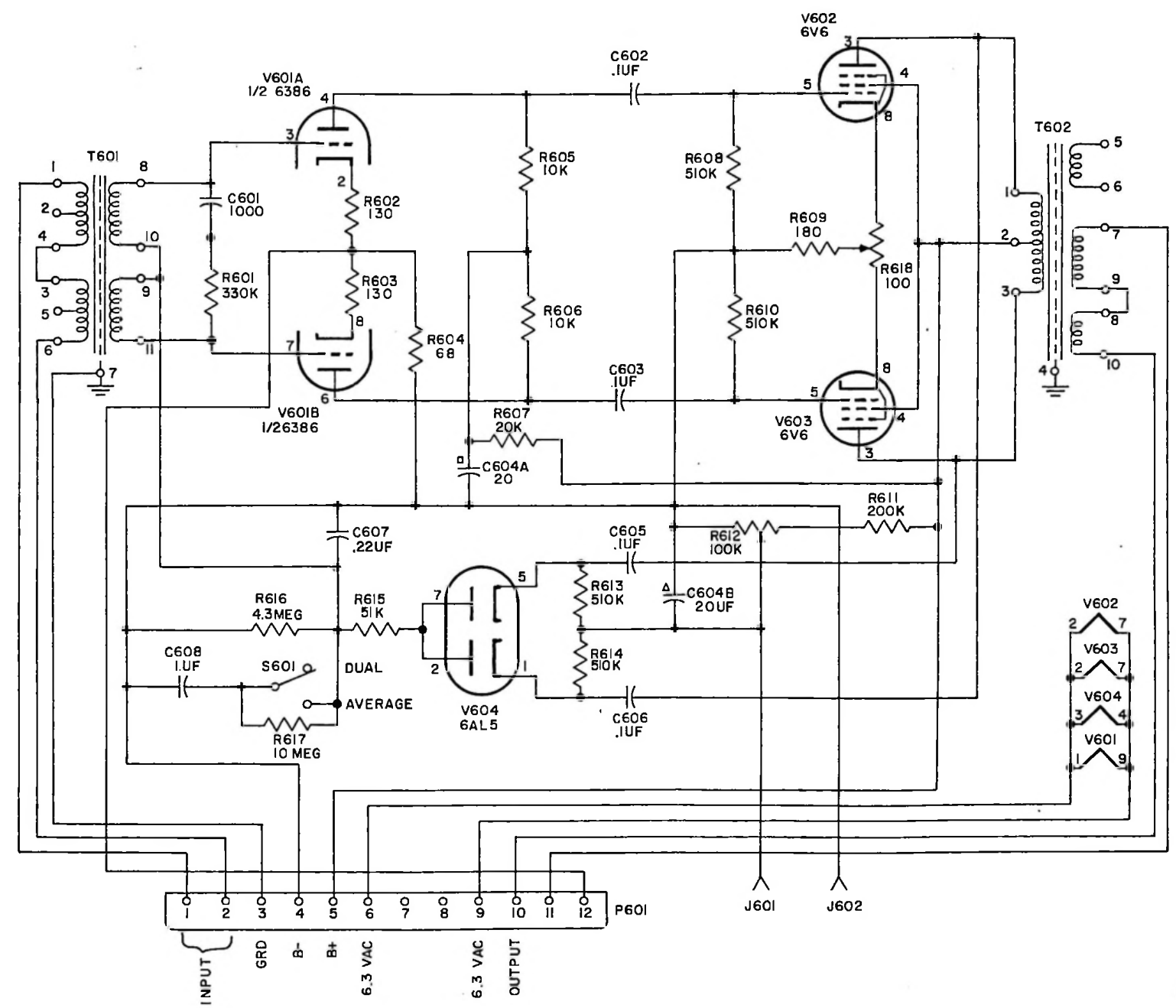

Figure 10. Limiter Amplifier, 356E-1 Bottom View

C99-43-P.



220,000
 2,200,000
 15,000,000
 4,309,000

NOTES
 1. UNLESS OTHERWISE SPECIFIED, RESISTOR VALUES ARE IN OHMS,
 CAPACITOR VALUES ARE IN MICROMICROFARADS.
 2. S601 SHOWN IN DUAL POSITION.

Figure 11. Limiter Amplifier 356E-1,
 Schematic Diagram

CUE AMPLIFIER 356Q-1

© **COLLINS RADIO COMPANY**
1960

CEDAR RAPIDS, IOWA, U.S.A.

PRINTED IN THE UNITED STATES OF AMERICA

COLLINS

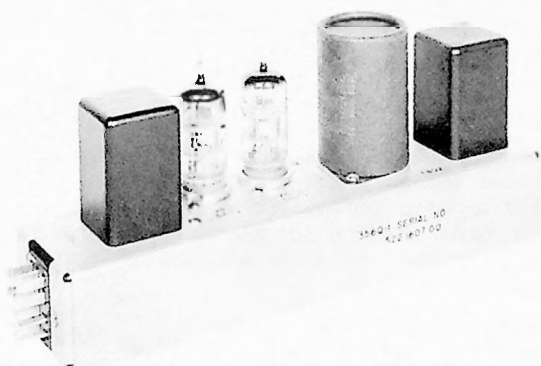

Figure 1. Cue Amplifier 356Q-1

CS83-14-P

1.1 PURPOSE OF EQUIPMENT.

Cue Amplifier 356Q-1 is intended for use as an audio amplifier with broadcast equipment, such as Collins Broadcast Console 212G-1. It may be used in AM, FM, and TV broadcast service or program control in audio systems for cueing tapes and records.

1.2 PHYSICAL DESCRIPTION.

The 356Q-1 (figure 1) is a plug-in module containing the necessary circuitry for two stages of audio amplification. The 356Q-1 is 4-5/8 inches high, 2-1/8 inches wide, and 9-1/2 inches long and weighs approximately 2-1/4 pounds.

1.3 TUBE COMPLEMENT.

FUNCTION	SYMBOL	TUBE TYPE
Input amplifier	V801	5879
Output amplifier	V802	5879

1.4 ELECTRICAL CHARACTERISTICS.

a. **CONNECTORS.** One 12-pin connector, P801, is located at the front end of the chassis. All connections to the 356Q-1 are made at this connector.

b. **POWER REQUIREMENTS.** Power requirements for Cue Amplifier 356Q-1 are as follows: 250-300 volts d-c filtered at 6.5-7.5 ma and 6.3 volts a-c or d-c at 0.3 ampere.

c. **FREQUENCY RANGE.** The frequency range of the 356Q-1 is 300 to 10,000 cycles per second.

d. **INPUT IMPEDANCE.** Cue Amplifier 356Q-1 is factory wired for 600 ohms unloaded transformer input impedance.

e. **GAIN.** A -30-dbm nominal input signal produces an output of +20 dbm nominal. Gain through the amplifier is 55 db.

f. **OUTPUT IMPEDANCE.** Cue Amplifier 356Q-1 is factory wired for 4 ohms output impedance.

g. **FREQUENCY RESPONSE.** The frequency response of the 356Q-1 is within 3 db from 300 to 10,000 cps.

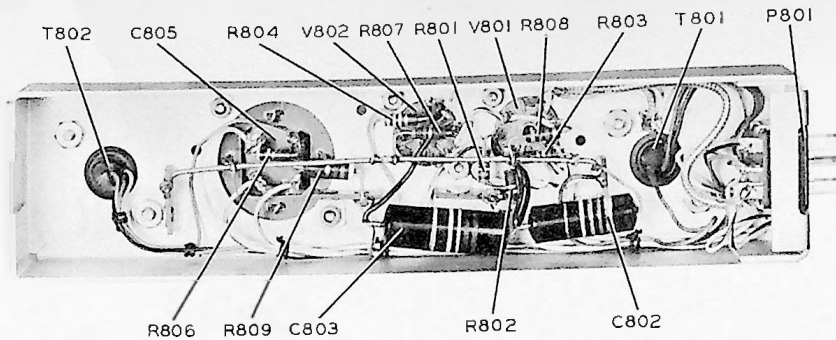

Figure 2. Cue Amplifier 356Q-1,
Bottom View

C583-22-P

h. NOISE LEVEL. The equivalent input noise level of Cue Amplifier 356Q-1 is -1000 dbm. When the 356Q-1 is used with Collins Power Supply 409X-2, the filaments are maintained at approximately +30 volts d-c above ground. This positive bias minimizes a-c noise in the amplifier.

2.1 CIRCUIT DESCRIPTION.

Figure 3 is a schematic diagram of Cue Amplifier 356Q-1. Input to the 356Q-1 is coupled by transformer T801 and the CUE gain control, R58, in the 212G-1, to the grid of V801.

NOTE

If Cue Amplifier 356Q-1 is used in equipment that does not provide a cue gain control, a 50,000-ohm potentiometer must be connected between terminals 8, 10, and 3 of P801. The potentiometer tap must be connected to terminal 8. Terminal 3 is ground.

The input amplifier, V801, is a pentode-connected type 5879. Its output is resistance-capacitance coupled to the grid of a triode connected type 5879, V802. Output from V802 is taken from the secondary winding of transformer T802. All connections to the 356Q-1 are made at P801.

3.1 MAINTENANCE.

Normal maintenance consists of tube replacement. Voltage and resistance measurements may be made by referring to figure 3.

4.1 REPLACEABLE PARTS.

The parts list gives the description and Collins part number for all replaceable parts in Cue Amplifier 356Q-1. When replacement of parts is necessary, only parts identical or equivalent to those listed should be used. All parts are identified in figure 2.

PARTS LIST

ITEM	DESCRIPTION	COLLINS PART NUMBER
CUE AMPLIFIER 356Q-1		522 1607 00
C801	NOT USED	
C802	CAPACITOR, FIXED, PAPER: 400 v dc; 47,000 uuf, ±10%	931 0295 00
C803	CAPACITOR, FIXED, PAPER: 0.1 uf ±10%, 400 v dc w	931 0299 00
C804	NOT USED	
C805	CAPACITOR, FIXED, ELECTROLYTIC: 4 sections; 1 & 2, 450 v dc working, 20 uuf; sections 3 & 4, 50 v dc working, 50 uf	183 1260 00
P801	CONNECTOR, RECEPTACLE, ELECTRICAL: 12 male contacts, 10 amps, 730 v ac	365 2120 00
R801	RESISTOR, FIXED, COMPOSITION: 0.16 megohms ±5%, 1/2 w	745 1445 00
R802	RESISTOR, FIXED, COMPOSITION: 0.10 megohms ±10%, 1/2 w	745 1436 00
R803	RESISTOR, FIXED, COMPOSITION: 51,000 ohms ±5%, 1/2 w	745 1424 00
R804	RESISTOR, FIXED, COMPOSITION: 0.47 megohms, ±10% 1/2 w	745 1464 00
R805	NOT USED	
R806	RESISTOR, FIXED, COMPOSITION: 30,000 ohms ±5%, 1/2 w	745 1413 00

ITEM	DESCRIPTION	COLLINS PART NUMBER
R807	RESISTOR, FIXED, COMPOSITION: 820 ohms ±5%, 1/2 w	745 1348 00
R808	RESISTOR, FIXED, COMPOSITION: 8200 ohms, ±10%, 1/2 w	745 1391 00
R809	RESISTOR, FIXED, COMPOSITION: 9100 ohms, ±5%, 1 w	745 3392 00
R801	TRANSFORMER, AUDIO, FREQUENCY: input type, primary 600 ohms, secondary 50,000 ohms; primary current rating-zero; secondary current rating-zero; metal encased. 1-5/16 x 1-5/16 x 2-1/16 in. h two threaded stud type terminals	667 0442 00
T802	TRANSFORMER, AUDIO, FREQUENCY: output type; primary 16,000 ohms; secondary 4 ohms; primary current rating-7 ma; secondary current rating-zero; metal encased 1-9/32 x 1-9/32 x 1-61/64 in. h; wire lead terminals	667 0441 00
V801	ELECTRON TUBE: type 5879	257 0104 00
V802	ELECTRON TUBE: same as V801	257 0104 00
XV801	SOCKET, ELECTRON TUBE: 9 contact miniature top mig tube socket w/o shield base; plastic	220 1274 00
XV802	SOCKET, ELECTRON TUBE: same as XV801	220 1274 00

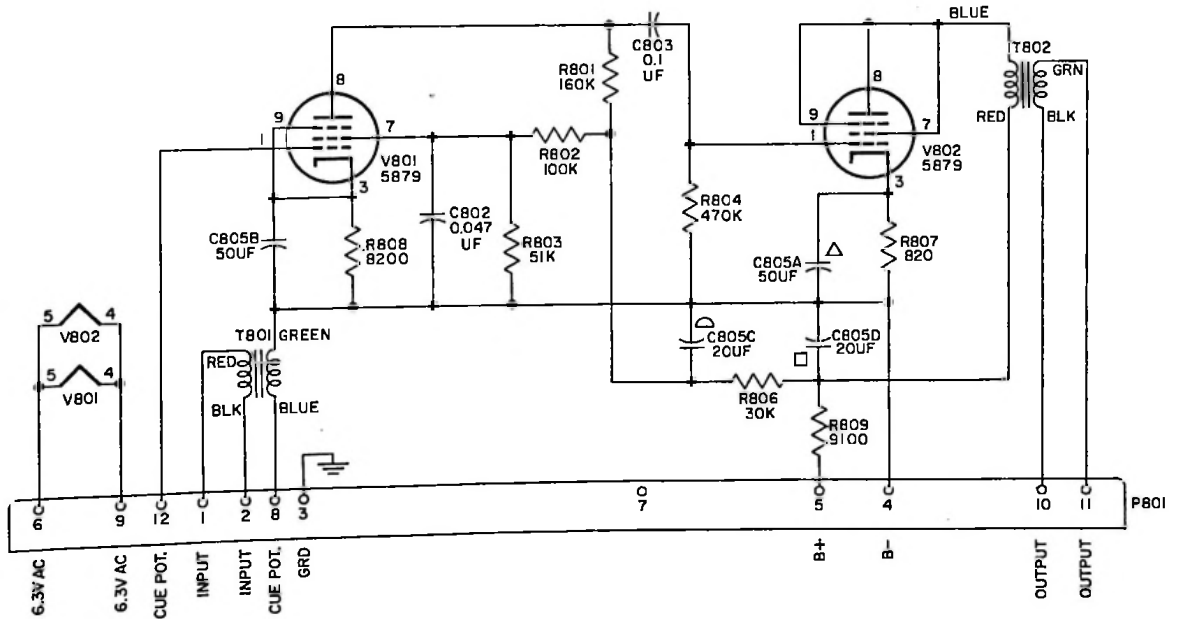

Figure 3. Cue Amplifier 356Q-1, Schematic Diagram

UNIT INSTRUCTIONS

TD-327
15 JANUARY 1960
523 0036 00

RELAY UNIT 274K-2

© COLLINS RADIO COMPANY
1960

CEDAR RAPIDS, IOWA, U.S.A.

PRINTED IN THE UNITED STATES OF AMERICA

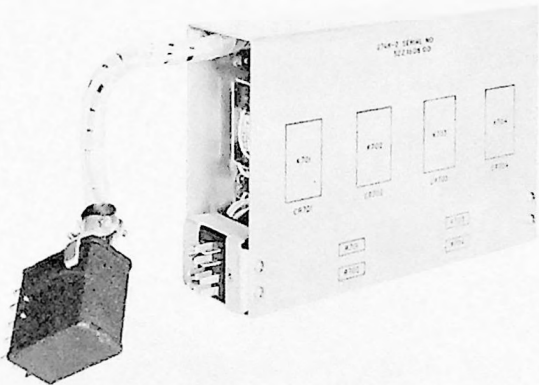

C583-13-P

Figure 1. Relay Unit 274K-2

1.1 PURPOSE OF EQUIPMENT.

Relay Unit 274K-2 controls application of audio power to station speakers and a-c power to studio warning lights when used with broadcast studio equipment, such as Collins Broadcast Console 212G-1. It may be used in AM, FM, and TV broadcast service or program control in audio systems.

1.2 PHYSICAL DESCRIPTION.

Relay Unit 274K-2 (figure 1) is a plug-in module containing four 12-volt d-c relays and their associated circuitry. The 274K-2 is provided with a cover to protect relay contacts from dust and damage while handling. The 274K-2 is 5-1/2 inches high, 2-1/2 inches wide, and 9-1/2 inches long and weighs approximately 2.5 pounds.

1.3 ELECTRICAL CHARACTERISTICS.

a. CONNECTORS. One 12-pin connector, P702, (Howard Jones Type P-312-AB) mounted on the front end of the chassis and one 15-pin connector, P701, (Howard Jones Type P-315-CCE) on a 5-1/2-inch pendant cable.

b. POWER REQUIREMENTS. Power requirements for Relay Unit 275K-2 are 12 volts d-c at 560 milliamperes.

c. NOISE. The four relays of the 274K-2 are mounted on rubber to minimize noise.

2.1 CIRCUIT DESCRIPTION.

Figure 3 is a schematic diagram of Relay Unit 274K-2. The relays are normally de-energized. When 12 volts d-c is applied, the relays are energized. All connections to the relay coils and contacts are made at P701 and P702. CR701 through CR704 are connected as transient suppressors across the relay coils to minimize radio interference and contact wear. Power necessary for operation of the relays must be supplied from an external source, such as Collins Power Supply 409X-2.

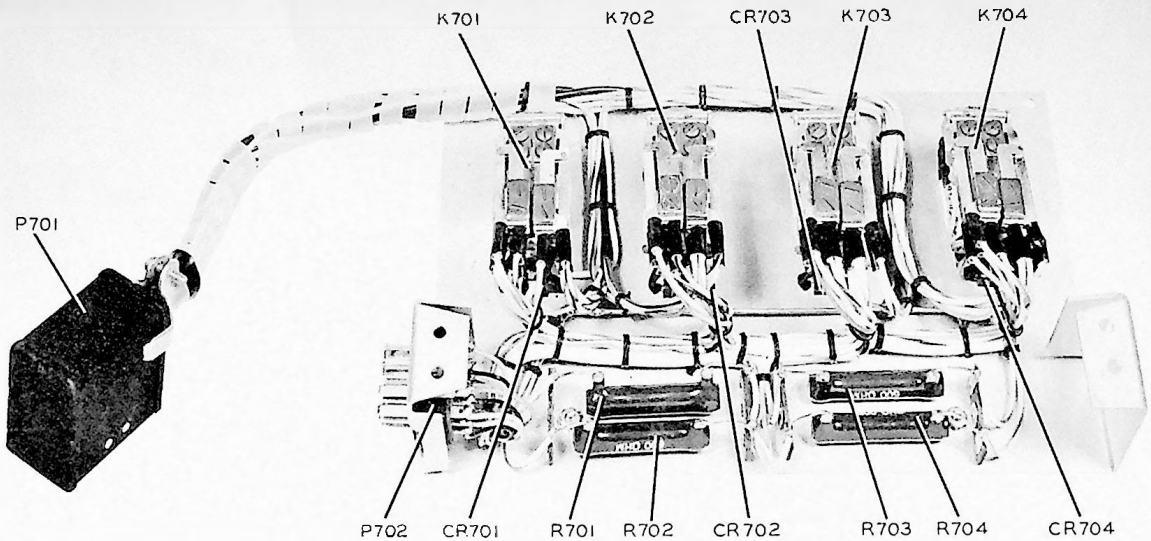

Figure 2. Relay Unit 274K-2, Cover Removed

C583-18-P

3.1 MAINTENANCE.

Relay Unit 274K-2 requires very little maintenance other than periodic inspections. Keep the relay contacts clean and bright. Refer to figure 3, if necessary, to perform continuity checks.

4.1 REPLACEABLE PARTS.

The parts list gives the description and Collins part number for all replaceable parts in Relay Unit 274K-2. When replacement of parts is necessary, only parts identical or equivalent to those listed should be used. All parts are identified in figure 2.

PARTS LIST

ITEM	DESCRIPTION	COLLINS PART NUMBER
	RELAY UNIT 274K-2	522 1606 00
CR701	SEMICONDUCTOR DEVICE, DIODE: germanium type 1N48; C.B.S. Hytron	353 0027 00
CR702 thru CR704	SEMICONDUCTOR DEVICE, DIODE: same as CR701	353 0027 00
K701	RELAY, ARMATURE: contact arrangement, right 1C, left 2C; 12 v, 3 amps, 150 w	970 1139 00
K702 thru K704	RELAY, ARMATURE: same as K701	970 1139 00

ITEM	DESCRIPTION	COLLINS PART NUMBER
P701	CONNECTOR, PLUG, ELECTRICAL: 15 male contacts; type 300	365 0150 00
P702	CONNECTOR, RECEPTACLE, ELECTRICAL: 12 male contacts, 10 amps, 730 v ac	365 2120 00
R701	RESISTOR, FIXED, WIRE WOUND: 600 ohms, ±10%, 7 w at 25°C derated linearly to 3.5 w at +105°C	710 9017 00
R702 thru R704	RESISTOR, FIXED, WIRE WOUND: same as R701	710 9017 00

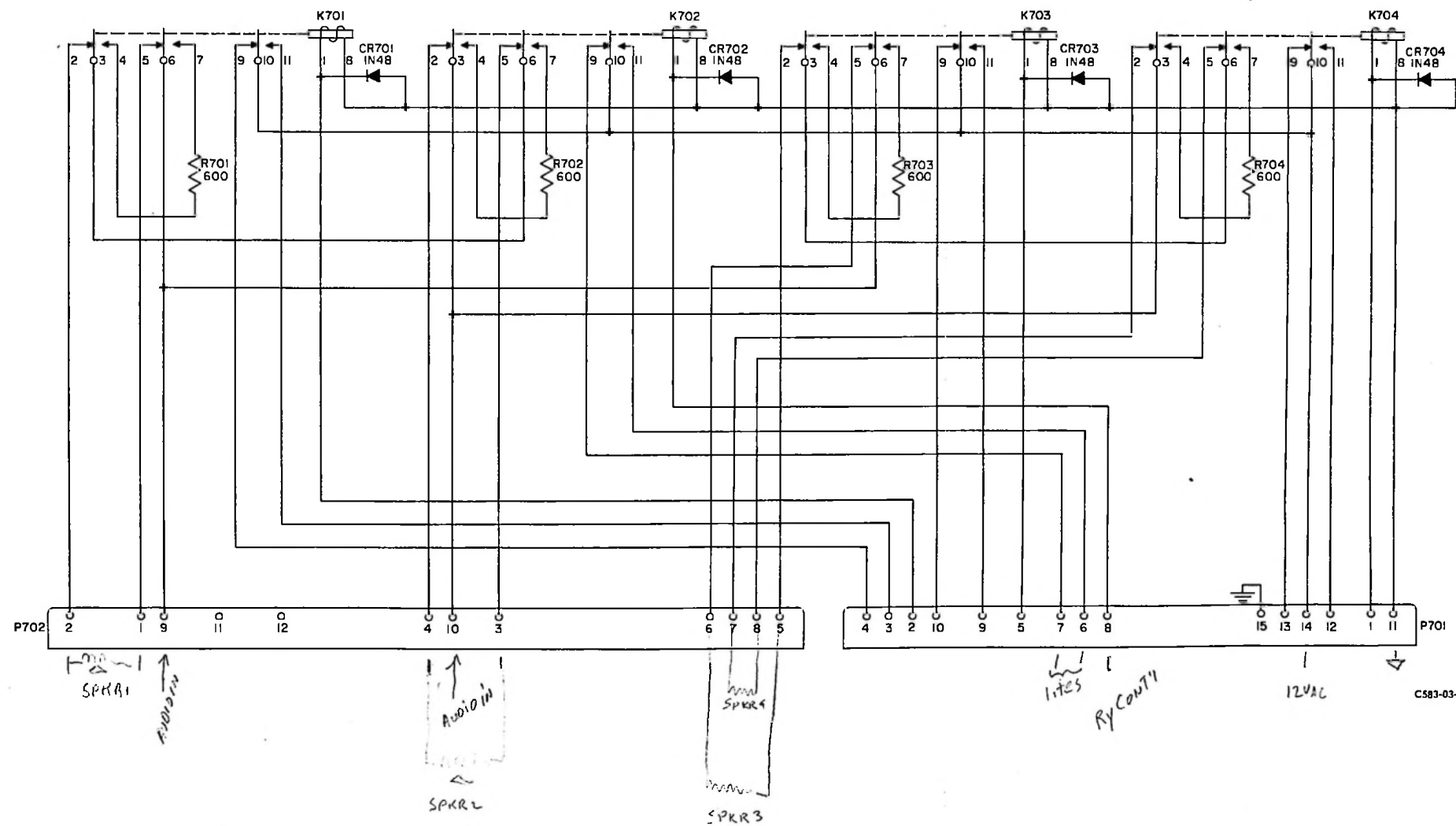

Figure 3. Relay Unit 274K-2, Schematic Diagram

POWER SUPPLY 409X-2

© COLLINS RADIO COMPANY
1960

CEDAR RAPIDS, IOWA, U.S.A.

PRINTED IN THE UNITED STATES OF AMERICA

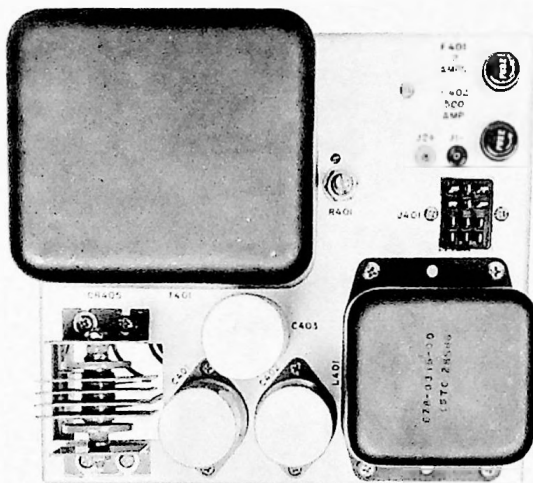

Figure 1. Power Supply 409X-2

C583-17-P

1.1 PURPOSE OF EQUIPMENT.

Power Supply 409X-2 furnishes power for filaments, plate circuits, and relays in Collins Broadcast Consoles 212E-1, 212F-1, and 212G-1.

1.2 PHYSICAL DESCRIPTION.

Power Supply 409X-2 (figure 1) is a plug-in power supply. It is 9 inches long, 8 inches wide, and 6 inches high and weighs 25 pounds.

1.3 ELECTRICAL CHARACTERISTICS.

- CONNECTORS. One 12-pin connector, J401, is located on top of the chassis. All connections to Power Supply 409X-2 are made at this connector.
- POWER SOURCE. The 409X-2 requires a 115- or 230-volt a-c $\pm 10\%$, 50/60-cps, single-phase power source capable of supplying 225 watts maximum power.
- OUTPUT VOLTAGES. The output of the 409X-2 is as follows: 250 to 300 volts d-c (adjustable) at 250 ma maximum, 6.3 volts a-c at 6.0 amperes, biased at approximately +30 volts d-c, 12 volts d-c at 1 ampere.

2.1 CIRCUIT DESCRIPTION.

Figure 3 is a schematic diagram of Power Supply 409X-2. The 409X-2 is factory wired for a 115-volt a-c operation, but may be connected to a 230-volt source if transformer T401 primary terminals are connected as follows: disconnect the wires from terminal 1 to terminal 2 and from terminal 3 to terminal 4 on TB401. Connect terminal 2 to terminal 3. Replace F401 with a 1.0-amp fuse. The power supply is protected by fuse F401 in the transformer primary circuit and by fuse F402 in the B- output lead. The 409X-2 has an unregulated output.

Four type 1N1492 silicon rectifiers, CR401 through CR404, are utilized to provide the high-voltage output. This output is filtered by C401, C402, and L401. The high-voltage output may be adjusted from 250 to 300 volts d-c by R401. A selenium rectifier, CR405, provides 12 volts d-c for operation of relays. The 12-volt supply is filtered by C403. The a-c power is supplied to the rectifying circuits from windings on T401. The winding associated with the 12-volt supply has a high-voltage tap to be used when necessary to compensate for aging of CR405. Another winding on T401 provides the 6.3-volt a-c for the filament string. This winding is biased with approximately +30 volts d-c to minimize a-c noise in the preamplifiers.

3.1 MAINTENANCE.

Normal maintenance consists of fuse replacement. Refer to figure 4, if necessary, to perform continuity or voltage checks. Test points J1- and J2+ are located on top of the chassis for ease of B+ adjustment.

4.1 REPLACEMENT PARTS.

The parts list gives the description and Collins part number for all replaceable parts in Power Supply 409X-2. When replacement of parts is necessary, only parts identical or equivalent to those listed should be used. All parts are identified in figure 2.

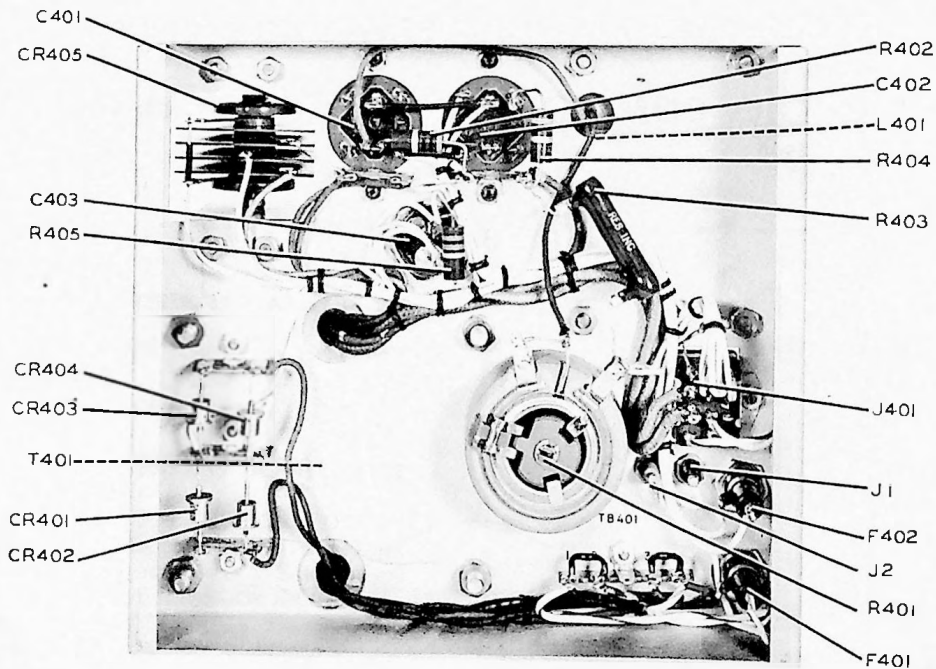
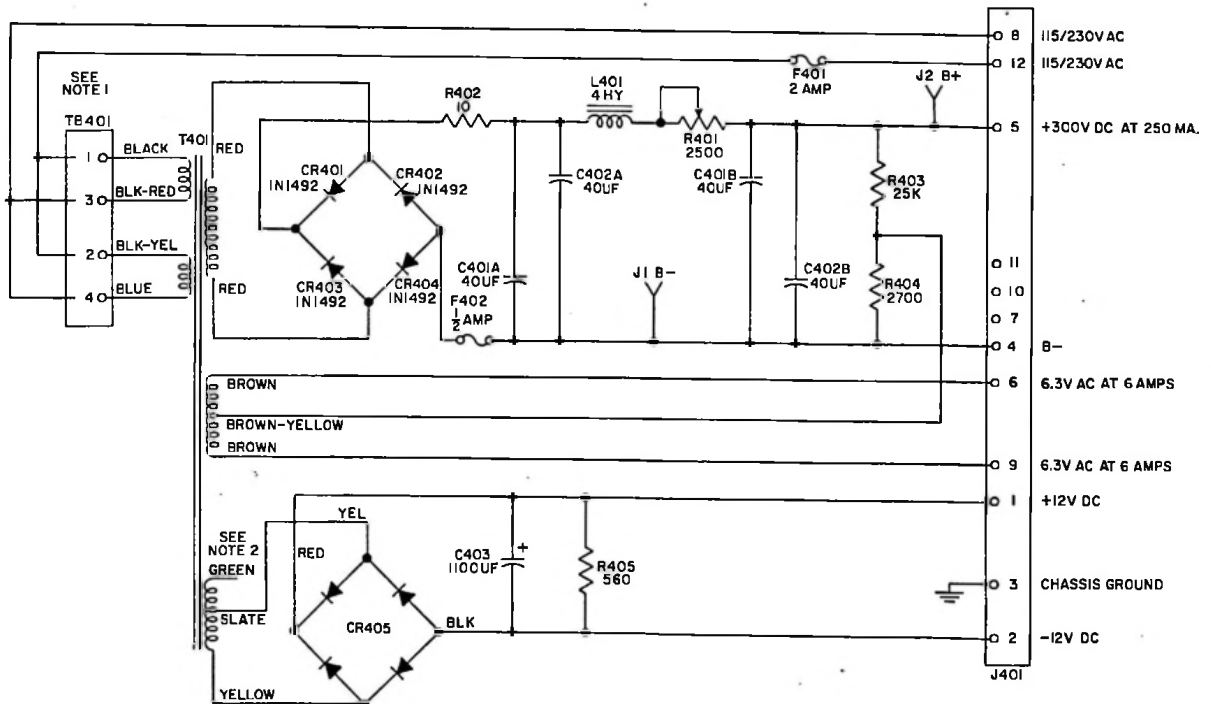

Figure 2. Power Supply 409X-2, Bottom View

C583-19-P

PARTS LIST

ITEM	DESCRIPTION	COLLINS PART NUMBER	ITEM	DESCRIPTION	COLLINS PART NUMBER
POWER SUPPLY 409X-2			522 1691 000		
C401	CAPACITOR, FXED, ELECTROLYTIC: dual section, 40 uf ea, +5% -10%, 450 v dc	183 1259 00	L401	REACTOR: 4.0 hy inductance 275 ma dc, 100 ohms dc resistance, metal encased, 3-1/4 in. by 4-1/32 in. by 3-7/8 in. h	668 0446 00
C402	CAPACITOR, FIXED, ELECTROLYTIC: same as C401	183 1259 00	R401	RESISTOR, VARIABLE, WIRE WOUND: 2500.0 ohms, ±10%, 50 w	736 0231 00
C403	CAPACITOR, FIXED, ELECTROLYTIC: 1100 uf, 25 v dc	184 2000 00	R402	RESISTOR, FIXED, COMPOSITION: 10 ohms, ±10%, 2 w	745 5568 00
CR401	RECTIFIER: silicon, General Electric IN1492	353 1661 00	R403	RESISTOR, FIXED, WIRE WOUND: 25,000 ohms, ±10%, 10 w	710 8068 00
CR402	RECTIFIER: same as CR401	353 1661 00	R404	RESISTOR, FIXED, COMPOSITION: 2700 ohms, ±10%, 2 w	745 5670 00
CR404			R405	RESISTOR, FIXED, COMPOSITION: 560 ohms, ±10%, 2 w	745 5642 00
CR405	RECTIFIER, METALLIC: selenium; Sarkes-Tarzian type 5N26-1B-1BBS	353 0254 00	T401	TRANSFORMER POWER STEP-UP, STEP-DOWN: encased, metal case, primary winding no. 1 and no. 2, 115 v each 230 connected, 50/60 cps secondary windings 265 v, 12.0 v, 13.5 v, 6.3 v ct	662 0445 00
F401	FUSE, CARTRIDGE: 2 amp, 125 v dc; time delay, ferrule type terminal	264 0008 00	TB401	TERMINAL BOARD: phenolic; incl 5 solder lug terminals; 1/16 in. by 3/8 in. by approx 1-15/16 in	306 0550 00
F402	FUSE, CARTRIDGE: 1/2 amp, 250 v; time delay, ferrule terminals; 1/4 in. dia. by 1-1/4 in. lg o/a	264 0293 00	XF401	FUSEHOLDER: extractor post type; 250 v, 15 amp	265 1003 00
J401	CONNECTOR, RECEPTACLE, ELECTRICAL: 12 male contacts, 10 amps, 730 v ac; straight shape	356 2120 00	XF402	FUSEHOLDER: same as XF401	265 1003 00
J1	JACK, TIP: accommodates standard phone tip, black plastic insulation, precious metal plated contact, terminal lug for wire accommodation	360 0063 00			
J2	JACK, TIP: accommodates std phone tip, red plastic insulation, precious metal plated contact, terminal lug for wire accommodation	360 0082 00			



NOTES:
1. T401 WIRED FOR 115V OPERATION. FOR 230V OPERATION MAKE FOLLOWING CHANGES ON TB401: REMOVE JUMPERS 1 TO 2 AND 3 TO 4, ADD JUMPER 2 TO 3. REPLACE F401 WITH 1 AMP FUSE.
2. GREEN LEAD OF T401 IS AN AGING TAP.

Figure 3. Power Supply 409X-2, Schematic Diagram

ELECTRICAL WIRE CODE

EXAMPLES

UNSHIELDED WIRE, MIL TYPE B #22 AWG, WHITE WITH RED AND GREEN TRACERS:

D	A	9	25	4-1/4
Type of Wire	Size of Wire	Color of Body	Color of Tracers	Length of Wire in Inches (Includes Stripping & Tinning)

SHIELDED WIRE (SINGLE), MIL TYPE C, #15 AWG, WHITE WITH RED AND GREEN TRACERS:

R	D	S	9	25	4-1/4
Type of Wire	Size of Wire	Shielded	Color of Body	Color of Tracers	Length of Wire in Inches (Includes Stripping & Tinning)

SHIELDED WIRE (MULTIPLE), MIL TYPE B, #22 AWG, WHITE, AND WHITE WITH RED TRACER:

D	A	S	(9)	(92)	4-1/4
Type of Wire	Size of Wire	Shielded	First Conductor	Second Conductor	Length of Wire in Inches (Includes Stripping & Tinning)

TYPE OF WIRE CODE			SIZE OF WIRE CODE		COLOR CODE	
LETTER	TYPE OF WIRE	FAMILY USUALLY FOUND IN	LETTER	SIZE	NUMBER OR LETTER	COLOR
A	Cotton Braid Over Plastic (Formerly AN-J-C-48)	440 Plain 443 Shielded	A	#22 AWG	0	Black
B	Busbar, Round Tinned	421	B	#20	1	Brown
C	MIL-W-16878 Type B (#20 and Larger) (600 Volts)	439	C	#18	2	Red
D	Miniature Wire, MIL-W-16878 Type B (#22 & Smaller)	439-7000 Series	D	#16	3	Orange
E			E	#14	4	Yellow
F	Extra Flexible Varnished Cambric	423	F	#12	5	Green
G			G	#10	6	Blue
H	Kel-F (Monochloro-trifluoroethylene)	422	H	#8	7	Violet
J			J	#6	8	Gray (Slate)
K	Neon Sign Cable (15,000 Volts)	423 0004 00	K	#4	9	White
L	Silicone	425 0942 00	L	#2	a	Clear
M			M	#1	b	Tan
N	Single Conductor Stranded (Not Rubber Covered)	422	N	#0	c	Pink
P	Single Conductor Stranded (Rubber Covered)	423	P	#00	d	Maroon
Q			Q	#000	e	Light Green
R	MIL-W-16878 Type C (1000 Volts)	439 1000 Series	R	#0000	f	Light Blue
T	Teflon, MIL-W-16878 Type E (600 Volts)	439 4000 Series	T	#28		
V	MIL-W-16878 Type D (3000 Volts)	439 3000 Series	V	#26		
W	Teflon, MIL-W-16878 Type EE (1000 Volts)	439 0000 Series	W	#24		
X			X	#19		
Y			Y	#30		
Z	Acetate Yarn Telephone Type	428	Z			



COLLINS RADIO COMPANY