

instruction book

Cedar Rapids Division | Collins Radio Company, Cedar Rapids, Iowa

**Peak Limiting Amplifier
26U-1**

Guarantee

The equipment described herein is sold under the following guarantee:

Collins agrees to repair or replace, without charge, any equipment, parts, or accessories which are defective as to design, workmanship or material, and which are returned to Collins at its factory, transportation prepaid, provided

- (a) Notice of the claimed defect is given Collins within one (1) year from date of delivery and goods are returned in accordance with Collins instructions.
- (b) Equipment, accessories, tubes, and batteries not manufactured by Collins or from Collins designs are subject to only such adjustments as Collins may obtain from the supplier thereof.
- (c) No equipment or accessory shall be deemed to be defective if, due to exposure or excessive moisture in the atmosphere or otherwise after delivery, it shall fail to operate in a normal or proper manner.

Collins further guarantees that any radio transmitter described herein will deliver full radio frequency power output at the antenna lead when connected to a suitable load, but such guarantee shall not be construed as a guarantee of any definite coverage or range of said apparatus.

The guarantee of these paragraphs is void if equipment is altered or repaired by others than Collins or its authorized service center.

No other warranties, expressed or implied, shall be applicable to any equipment sold hereunder, and the foregoing shall constitute the Buyer's sole right and remedy under the agreements in this paragraph contained. In no event shall Collins have any liability for consequential damages, or for loss, damage or expense directly or indirectly arising from the use of the products, or any inability to use them either separately or in combination with other equipment or materials, or from any other cause.

How to Return Material or Equipment

If, for any reason, you should wish to return material or equipment, whether under the guarantee or otherwise, you should notify us, giving full particulars including the details listed below, insofar as applicable. If the item is thought to be defective, such notice must give full information as to nature of defect and identification (including part number if possible) of part considered defective. (With respect to tubes we suggest that your adjustments can be speeded up if you give notice of defect directly to the tube manufacturer.) Upon receipt of such notice, Collins will promptly advise you respecting the return. Failure to secure our advice prior to the forwarding of the goods or failure to provide full particulars may cause unnecessary delay in the handling of your returned merchandise.

ADDRESS:

Collins Radio Company
Service Division
Cedar Rapids, Iowa

INFORMATION NEEDED:

- (A) Type number, name and serial number of equipment
- (B) Date of delivery of equipment
- (C) Date placed in service
- (D) Number of hours of service
- (E) Nature of trouble
- (F) Cause of trouble if known
- (G) Part number (9 or 10 digit number) and name of part thought to be causing trouble
- (H) Item or symbol number of same obtained from parts list or schematic
- (I) Collins number (and name) of unit subassemblies involved in trouble
- (J) Remarks

How to Order Replacement Parts

When ordering replacement parts, you should direct your order as indicated below and furnish the following information insofar as applicable. To enable us to give you better replacement service, please be sure to give us complete information.

ADDRESS:

Collins Radio Company
Service Division
Cedar Rapids, Iowa

INFORMATION NEEDED:

- (A) Quantity required
- (B) Collins part number (9 or 10 digit number) and description
- (C) Item or symbol number obtained from parts list or schematic
- (D) Collins type number, name and serial number of principal equipment
- (E) Unit subassembly number (where applicable)

INSTRUCTION BOOK

PEAK LIMITING AMPLIFIER 26U-1

520 5770 00
1 JULY 1958

© **COLLINS RADIO COMPANY**
1958

CEDAR RAPIDS, IOWA, U.S.A.

PRINTED IN THE UNITED STATES OF AMERICA



TABLE OF CONTENTS

Section		Page
I	GENERAL DESCRIPTION	1
1.1	Purpose of Instruction Book	1
1.2	Purpose of Equipment	1
1.3	Description	1
1.4	Equipment Supplied	1
1.5	Custom Modification	1
1.6	Specifications and Performance Data	1
1.7	Fuse	3
II	INSTALLATION	3
2.1	Unpacking	3
2.2	Mounting	3
2.3	Connections	3
2.3.1	Power Connections	3
2.3.2	Audio Connections	3
2.3.2.1	Unbalanced Input	3
2.3.2.2	Balanced Input	3
2.3.2.3	Unbalanced Output	3
2.3.2.4	Balanced Output, Adjustable	3
2.3.2.5	Balanced Output, Fixed	4
2.3.3	External Meter Connections	4
2.3.3.1	G. R. External	4
2.3.3.2	External Audio	4
2.4	Initial Adjustments	4
2.4.1	Adjustment Procedure	5

List of Illustrations

Section	Page
III OPERATION	5
3.1 Description of Controls	5
3.1.1 Panel Controls	5
3.1.2 Internal Controls	6
3.2 Routine Operation	6
IV PRINCIPLES OF OPERATION	7
4.1 General	7
4.2 Audio Amplifier Circuits	7
4.3 Peak Limiting Control Circuits.	7
4.4 Power Supply Circuits.	7
4.5 Metering Circuits	7
V MAINTENANCE	10
5.1 Operator's Check.	10
5.2 Bench Performance Test	10
5.2.1 Test Equipment Required	10
5.2.2 Test Conditions	10
5.2.3 Initial Adjustments	10
5.2.3.1 G. R. Zero Setting	10
5.2.3.2 G. R. Bal.	11
5.2.4 Test Procedure	11
5.2.4.1 Plate Voltage	11
5.2.4.2 Attack and Release Time	12
5.2.4.3 Distortion Measurements	12
5.2.4.4 Noise Level	12
5.2.4.5 Compression Ratio	12
5.2.4.6 Frequency Response	12
5.2.4.7 Gain	12
5.3 Maintenance	12
5.3.1 Resistance and Voltage Measurements	12
5.3.2 Rectifier Replacement	12
5.3.3 Tube Replacement	13
5.3.4 Meter Lamp Replacement	13
VI PARTS LIST	14
VII ILLUSTRATIONS	19

LIST OF ILLUSTRATIONS

Figure	Page
1-1 Peak Limiting Amplifier 26U-1 (C291-11-P)	iv
1-2 Limiting Characteristic Curve (C291-05-X)	2
2-1 Resistance Values for 600-Ohm Fixed Pads (C89-18-3)	4
3-1 Operating Controls (C291-10-P)	6
4-1 Peak Limiting Amplifier 26U-1, Block Diagram (C291-02-3)	8
4-2 Metering Circuits, Simplified Diagram (C291-01-3)	9
5-1 Test Setup, Block Diagram (C291-06-3)	10
5-2 Peak Limiting Amplifier 26U-1, Attack Time (C291-08-P)	11
5-3 Peak Limiting Amplifier 26U-1, Unbalanced (C291-07-P)	11
5-4 Peak Limiting Amplifier 26U-1, Release Time (C291-09-P)	11

Figure		Page
6-1	Peak Limiting Amplifier 26U-1, Front View, Panel Lowered (C291-12-P)	14
6-2	Peak Limiting Amplifier 26U-1, Inside Front Panel (C291-13-P)	15
6-3	Peak Limiting Amplifier 26U-1, Inside Control Panel (C291-14-P)	15
6-4	Peak Limiting Amplifier 26U-1, Rear View (C291-15-P)	16
7-1	Peak Limiting Amplifier 26U-1, Schematic Diagram (C291-04-6)	19
7-2	Conversion to Balanced Input and Output (C291-03-3)	20

LIST OF TABLES

Table		Page
1-1	Tube and Rectifier Complement	1
5-1	Resistance and Voltage Measurements	13

SECTION I
General Description

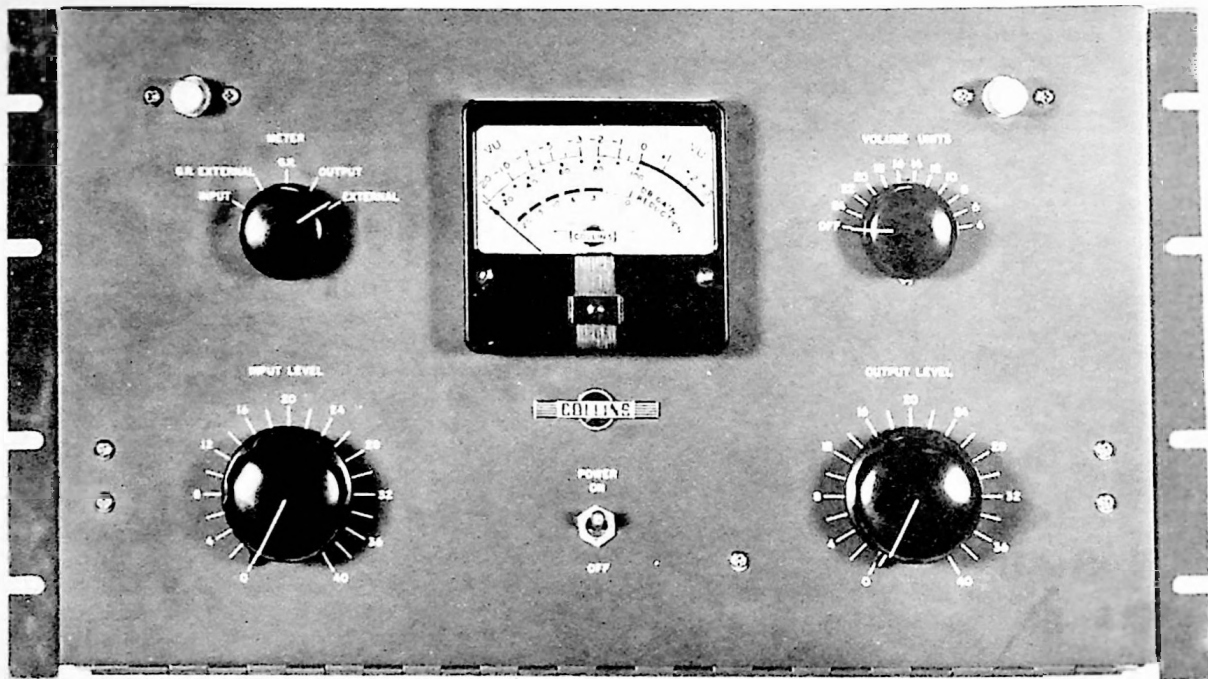

Figure 1-1. Peak Limiting Amplifier 26U-1

SECTION I GENERAL DESCRIPTION

1.1 PURPOSE OF INSTRUCTION BOOK.

This instruction book is to be used as a guide to the installation, adjustment, operation, and maintenance of Collins Peak Limiting Amplifier 26U-1. See figure 1-1.

1.2 PURPOSE OF EQUIPMENT.

Collins Peak Limiting Amplifier 26U-1 is for use in any installation where it is desired to control the amplitude of audio-frequency peaks. In transmitter applications it will prevent overmodulation by limiting the loud audio passages. This limiting action permits a higher average modulation level resulting in an increase in the transmission range or service area of the signal and an increase in the over-all efficiency of the transmitter. When used in conjunction with recording equipment or public address systems, it prevents overloading and by raising the average audio level, improves the signal-to-noise ratio. A further increase in the average modulation level can be obtained by using Limiting Amplifier 356E-1 ahead of the Peak Limiting Amplifier 26U-1. The 356E-1 limits the average amplitude rather than the peak amplitude. The 26U-1 is capable of 35 db gain and may be used simply as a straight amplifier for this 35 db gain.

1.3 DESCRIPTION.

The 26U-1 mounts in any standard 19-inch relay rack or cabinet such as the Collins type 19G-2 or 19G-3. Vertical mounting space of 10-1/2 inches is required. The equipment is assembled on a vertical chassis in such a manner that all wiring and circuit components except fuse and tubes are accessible by lowering the front panel which is hinged at the bottom. The tubes and fuse are accessible from the rear of the unit. External connections are made at the rear of the unit to a Howard Jones barrier strip and an a-c connector. The panel and mounting angles are finished in Collins 4E gray enamel. The chassis is cadmium plated and chromate dipped.

The 26U-1 consists of a push-pull variable gain input stage, a push-pull interstage voltage amplifier, and a push-pull output stage. A bias rectifier supplies d-c bias from the signal output to regulate the gain of the input stage. A self-contained power supply provides the B+ and filament voltages. A meter indicates the functioning of three internal circuits: INPUT, G.R., and OUTPUT. In addition, the meter can be switched to two external circuits: G.R. EXTERNAL and EXTERNAL audio. The G.R. EXTERNAL circuit is included so that the gain reduction of an associated

356E-1 Limiting Amplifier, if used, can be measured. The EXTERNAL audio metering circuit is an extra feature that can be used to measure audio levels in other broadcast audio equipment.

1.4 EQUIPMENT SUPPLIED.

The equipment, supplied under part number 522 0966 00, consists of Peak Limiting Amplifier 26U-1 complete with tubes, rectifiers, fuse, and a-c plug.

1.5 CUSTOM MODIFICATION.

a. Attenuator for adjustable balanced output: Replace AT2 with Collins part number 378 0085 00. (See figure 7-2 and paragraph 2.3.2.4.)

b. Attenuator for balanced "H" input: Replace AT1 with 378 0085 00. Also change the fixed T-pad to an H-pad using the following parts: four resistors - R1, R2, R1A, and R2A; part number 745 1320 00; 1/2 watt, 180 ohm p/m 5%. One resistor - R3; part number 745 1330 00; 1/2 watt, 330 ohm p/m 5%. (See figure 7-2.)

TABLE 1-1
TUBE AND RECTIFIER COMPLEMENT

QUANTITY	TYPE	APPLICATION
1	GL-6386	Variable gain input stage
1	12AU7	Interstage voltage amplifier
2	6V6GR	Output amplifier
1	6AL5	Limiter bias rectifier
2	1N1084	Power rectifier (silicon, commercial)
1	OA2	Voltage regulator

1.6 SPECIFICATIONS AND PERFORMANCE DATA.

Type of service . . . Continuous, unattended operation.

Size 10-1/2 inches high, 19 inches wide, 9 inches deep.

Audible noise None.

Number of units . . . One.

SECTION I
General Description

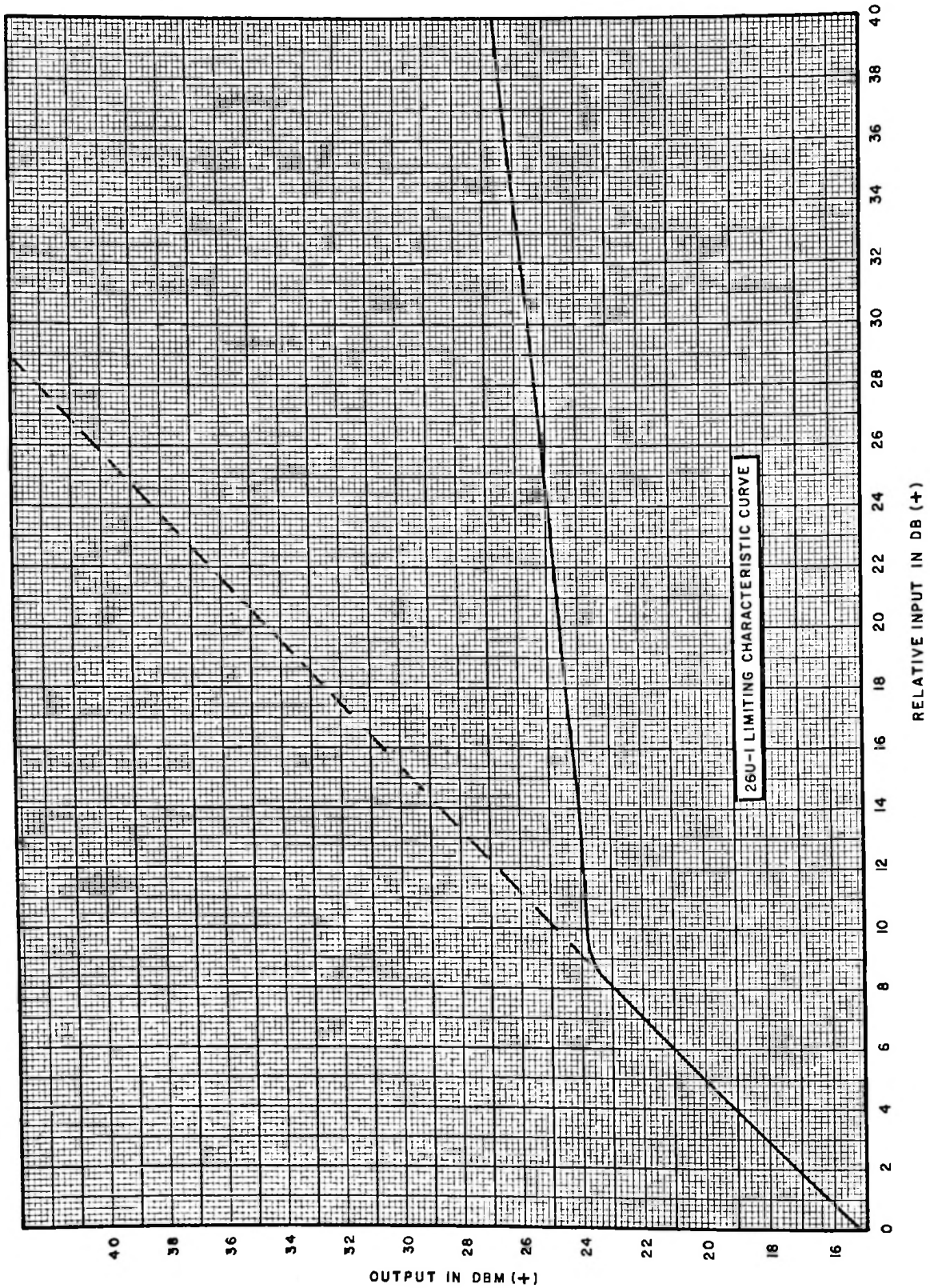

Figure 1-2. Limiting Characteristic Curve

Ambient temperature range +15°C to +45°C.

Ambient humidity range. Up to 95%

Altitude Up to 10,000 feet.

Shock conditions Normal handling and transportation.

Vibration conditions . . Normal handling and transportation.

Power source 115 or 230 volts a-c, 50/60 cps, single phase. Shipped wired for 115 v.

Input impedance 600 ohms unbalanced.

Input level -20 dbm to +20 dbm.
Note: 0 dbm equals one milliwatt across 600 ohms.

Output impedance 600 ohms unbalanced adjustable, or 600 ohms balanced fixed level.

Output level -20 dbm to +20 dbm.

Response ±1.5 db, 50 to 15,000 cps.

Distortion 1.5% maximum.

Output noise -50 dbm or less.

Compression ratio . . . 12 to 1 first 10 db above threshold, see figure 1-2.

Attack time Adjustable, 1/2 to 3.0 milliseconds.

Release time Adjustable, 2.2 to 5.2 seconds for 63% recovery.

Maximum gain 32 db minimum.

1.7 FUSE.

The 26U-1 is equipped with a 3/4-amp 250-volt, post-mounted, slow-blow fuse. Change to a 1/2-amp fuse when reconnecting for 230-volt operation.

SECTION II INSTALLATION

2.1 UNPACKING.

Remove all packing material and search for small packages. Inspect the unit for loose screws or bolts. Be certain that all controls work properly. All claims for damage should be filed promptly with the transportation company. If a claim for damage is to be filed, the original packing case and material must be preserved.

2.2 MOUNTING.

- a. Place the unit in position in a Collins type 19G-3 cabinet or similar standard relay rack cabinet.
- b. Secure the unit with hexagonal or roundhead screws and flat washers.
- c. Place tubes in sockets.

2.3 CONNECTIONS.

2.3.1 POWER CONNECTIONS.

When shipped, the unit is connected for 115-volt operation. If 230-volt operation is desired, reconnect the primary of the power transformer as shown on the main schematic diagram, figure 7-1. This puts the two halves of the primary in series. Change the fuse to 1/2 amp, 250 volt, slow-blow. The power connection is made to the plug inserted in J1 at the rear of the chassis.

2.3.2 AUDIO CONNECTIONS.

All audio connections are made to the barrier-type terminal strip located at the back of the unit near the bottom edge. Use shielded wire for all audio connections to minimize hum pickup. The input and output impedances of the 26U-1 are 600 ohms.

2.3.2.1 UNBALANCED INPUT. Connect the input line to terminals 11 and 12 of TB1 with the low side of the line going to terminal 12.

2.3.2.2 BALANCED INPUT. Under normal conditions the 26U-1 can be fed from a balanced input because the input circuit is not grounded. If a perfectly balanced input is desired, change the input circuit as shown in figure 7-2. The parts necessary for the conversion are listed in paragraph 1.5.

The conversion changes the fixed pad to an H-pad and the attenuator AT1 to a balanced ladder. Make connections to terminals 11 and 12 of TB1.

2.3.2.3 UNBALANCED OUTPUT. Connect the output line to terminals 1 and 2 of TB1 with the low side of the line going to terminal 2.

2.3.2.4 BALANCED OUTPUT, ADJUSTABLE. Under normal conditions the 26U-1 can be fed into a balanced

SECTION II
Installation

load because the output circuit is not grounded. If used in this manner, the center tap of the transmitter input transformer must not be grounded. If a perfectly balanced output is desired, change the output circuit to be identical to the output circuit shown in figure 7-2. The parts necessary for the conversion are listed in paragraph 1.5. This conversion changes the output attenuator to a balanced ladder. The output pad is already an H-pad so no change is necessary. Connect the output line to terminals 1 and 2 of TB1.

2.3.2.5 BALANCED OUTPUT, FIXED. Terminals 3 and 4 of TB1 become a balanced output connection merely by turning OUTPUT LEVEL attenuator AT2 to cue (extreme ccw position). When this is done, the output attenuator AT2 is bypassed. An external output level attenuator must be provided to control levels. This can be of the balanced ladder type and inserted in the line between the 26U-1 and the load.

2.3.3 EXTERNAL METER CONNECTIONS.

Meter M1 can meter two external circuits. METER select switch S1 has two positions that are wired to the external connector TB1. One position, G.R. EXTERNAL, can be connected to an associated 356E-1 Limiting Amplifier to indicate the gain reduction obtained in that amplifier. The other position, EXTERNAL, can be used to indicate audio level in 600-ohm circuits.

2.3.3.1 G.R. EXTERNAL. To use this circuit with Limiting Amplifier 356E-1, connect terminal 8 of TB1 through an external 1000-ohm zeroing variable resistor to terminal 12 of the 356E-1, and connect terminal 10 of TB1 to terminal 3 of the 356E-1.

2.3.3.2 EXTERNAL AUDIO. To use the external circuit, connect terminals 6 and 7 of TB1 to any 600-ohm audio circuit of less than +27 dbm. The meter indicates audio levels of -16 dbm to +27 dbm using the VOLUME UNITS AT3 attenuator in the 26U-1 as meter multiplier. For example, with the VOLUME UNITS attenuator set at 24, 0 VU read on the meter will be

24 volume units. The meter reads up to +3 VU, hence the meter will be reading +27 volume units at +3 VU.



When measuring signals of unknown level, be sure to preset the VOLUME UNITS attenuator to OFF, and gradually advance the attenuator as needed.

2.4 INITIAL ADJUSTMENTS.

Determine the level of the audio signal being delivered to the input of the 26U-1 with the studio equipment in normal operation. The Collins 212E and 212F Consoles, as do most other modern consoles, supply +8 vu to the line when the console VU meter reads 0 VU. Normal studio program operation would be with the console VU meter peaking at 0 VU or 100 on the percent scale.

If the input level to the 26U-1 is too high to allow good control range of the INPUT LEVEL control, an external pad can be connected in the line at the input terminals of the 26U-1 or at the output terminals of the console. See figure 2-1 for proper values of resistors in making up pads. The input level at the 26U-1 should be held to within the range -20 to +20 dbm (-30 to +10 volume units).

NOTE

A program wave form with high peaks is a complex wave and is read in volume units. The usual conception is to assume that the peaks are 10 db above the sine wave peaks. When testing with a sine wave, it is normal to test at a level 10 db higher than the normal volume unit level.

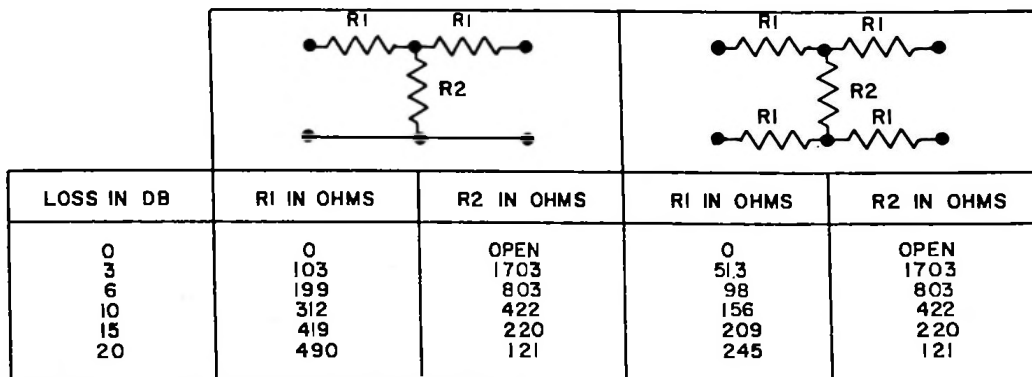

Figure 2-1. Resistance Values for 600-Ohm Fixed Pads

In place of making up an external pad to reduce the audio level, the internal 12-db pad consisting of R1, R2, and R3 can be changed to a pad of higher attenuation.

If the input level to the 26U-1 is too low, the internal pad consisting of R1, R2, and R3 can be changed to a pad of lower attenuation or it can be eliminated entirely to gain about 12 db.

If Limiting Amplifier 356E-1 is used along with the 26U-1, a suitable pad must be used because the output of the 356E-1 can be too high to be controlled by the INPUT LEVEL control.

2.4.1 ADJUSTMENT PROCEDURE.

a. Set the INPUT LEVEL and OUTPUT LEVEL controls to off positions (OUTPUT LEVEL control at ccw position but not in cue position), set the METER switch to EXTERNAL, and set the VOLUME UNITS attenuator to OFF.

b. Turn on the equipment, and after a five-minute stabilization period, turn the METER switch to G.R. Allow the front panel to tip forward slightly, and adjust the G.R. ZERO control until the meter indicates 0 on the DB GAIN REDUCTION scale with no audio input to the 26U-1.

NOTE

Always allow stabilization period before zeroing gain reduction.

c. Latch the front panel and feed program material from the console at the normal level that the control room operators will be using. This would be with the console VU meter peaking at 100 percent. With the METER switch set at INPUT, check the input level to see that the input level at the 26U-1 is proper for the output level of the console considering line losses.

d. Set the METER switch to G.R., and gradually advance the INPUT LEVEL control until the 100-percent peaks on the console output meter result in 3 to 5 db limiting as indicated on the DB GAIN REDUCTION scale of the 26U-1 meter.

e. With the OUTPUT LEVEL control still turned off, turn on the transmitter, and adjust for normal r-f output. Adjust the modulation monitor carrier input controls in the normal manner, being sure to adjust the tuning control accurately to a peak before carefully adjusting the straight monitor gain control for the index setting.

f. Set the flasher control dial on the monitor for 95 percent.

g. Gradually increase the 26U-1 OUTPUT LEVEL control until the modulation monitor flasher just lights with program peaks which result in the 3 to 5 db limiting peaks mentioned in step d.

h. Open the front panel, and set the ATTACK (R36) and RELEASE (R38) time controls. An attack time of 1.0 millisecond and a release time of 2.5 seconds is commonly used for all-around operation. Refer to paragraph 5.2.4.2 for a method to use in checking the attack and release time of the 26U-1.

i. If the limiting action has a tendency to produce a thump, refer to paragraph 5.2.3.2 in section V for the method of setting the G.R. BAL. control to prevent this condition.

SECTION III OPERATION

3.1 DESCRIPTION OF CONTROLS.

3.1.1 PANEL CONTROLS. (See figure 3-1.)

a. POWER ON-OFF. This switch is inserted in series with the power line to the power transformer. When it is in the OFF position, both sides of the line are disconnected from the power transformer.

b. INPUT LEVEL. This control is used to adjust the audio input to the 26U-1. The level of the audio input determines the degree of gain reduction (compression) obtained with the 26U-1. Set this control to obtain the desired degree of gain reduction as shown on the DB GAIN REDUCTION scale of the meter when the METER switch is in the G.R. position.

c. OUTPUT LEVEL. This control adjusts the audio output level of the 26U-1. The setting of this control depends upon the requirements of the transmitter with which the 26U-1 is used. Set this control at the

position where audio peaks capable of producing gain reduction modulate the transmitter 95%. See paragraph 2.4.1 for a detailed explanation of the method of setting this control.

d. METER. This switch selects the circuits to be read on the meter. In the INPUT position the meter reads audio level at the input terminals of the 26U-1. In the G.R. position, the meter reads the value of gain reduction on the DB GAIN REDUCTION scale of the meter. In the OUTPUT position, the meter reads the audio level at the output terminals of the 26U-1. The G.R. EXTERNAL and EXTERNAL positions of the switch are for external circuits and, if used, are connected by the customer.

e. VOLUME UNITS. This attenuator is used to vary the amount of attenuation in series with the meter when the meter is used to measure audio levels. It contains a switch which breaks the circuit to the meter when placed in the OFF position. The attenuator is

SECTION III
Operation

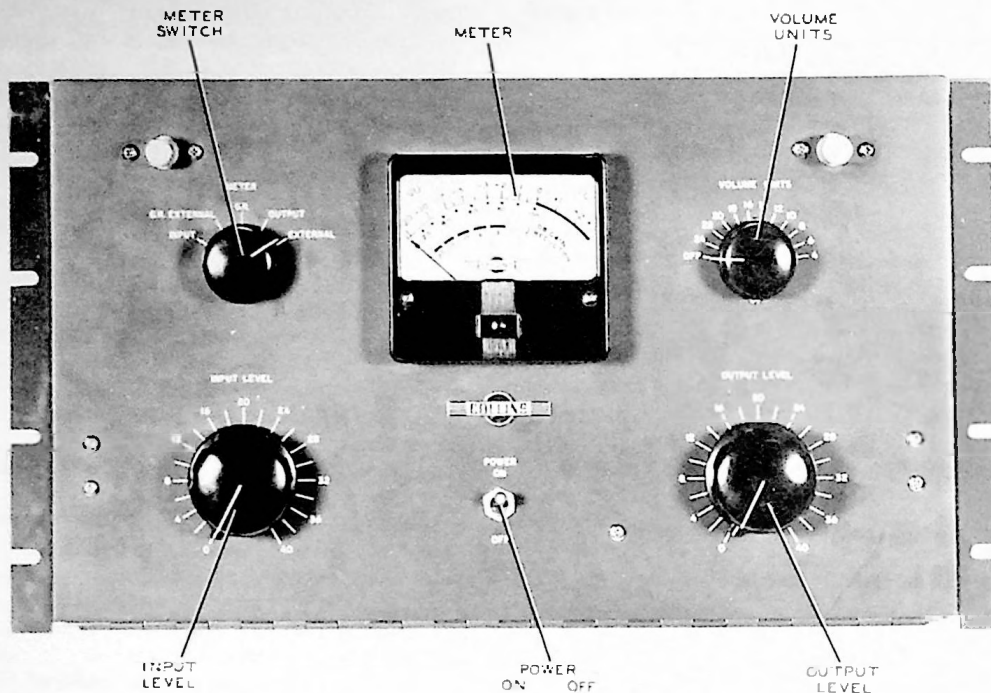

Figure 3-1. Operation Controls

calibrated in steps of 2 vu (volume units). The calibration of the attenuator is correct only when the meter is indicating 0 on the VU scale. The VOLUME UNITS attenuator is not used when the meter is reading gain reduction.

CAUTION

When measuring audio signals of unknown level, start with the VOLUME UNITS attenuator set to OFF, and gradually advance the control as needed. This will prevent banging the meter and possibly damaging it.

3.1.2 INTERNAL CONTROLS.

The internal controls are preset to proper positions by the station engineer and require no further adjustment by the operating personnel.

3.2 ROUTINE OPERATION.

a. Set the INPUT LEVEL and OUTPUT LEVEL controls to off (ccw position). Set the VOLUME UNITS control to OFF.

b. Turn on the 26U-1, and allow a five minute warm-up period.

c. Turn the METER switch to G.R., and with no input signal, check to see that the meter reads 0 on

the DB GAIN REDUCTION scale. If not, open the panel, and adjust the G.R. ZERO control for 0 indication on the meter.

d. Turn the METER switch to G.R. Feed program material into the console at normal level and advance the INPUT LEVEL control until the loudest passages of the audio produce 3 to 5 db* gain reduction.

e. Assuming that the transmitter has been turned on and warmed up and the modulation monitor has been correctly tuned and calibrated to 95% modulation, gradually increase the OUTPUT LEVEL until the flasher on the modulation monitor just flashes on the peaks which result in 3 to 5 db* gain reduction.

f. Change the METER switch to OUTPUT, and adjust the VOLUME UNITS switch to the setting which results in comparable action of the 26U-1 and the console vu meters at audio signals below the threshold of the limiter. (This output meter can be adjusted to the individual requirements of the station engineer.)

NOTE

Paragraph 2.4.1 contains detailed information on adjusting the equipment for operation. Once the equipment is adjusted per paragraph 2.4.1, the information in paragraph 3.2 should be sufficient for routine operation.

*These figures may be changed by the station engineer to meet the individual needs of the station.

SECTION IV PRINCIPLES OF OPERATION

4.1 GENERAL.

The 26U-1 is an audio peak limiting amplifier used in broadcast stations to raise the average level of modulation and prevent overmodulation. Its use in any audio application will increase the signal-to-noise ratio and lessen the possibility of distortion by limiting the audio peaks. The 26U-1 consists of a three-stage amplifier, in which the gain of the first stage is limited automatically by a system which utilizes the audio peaks above a fixed threshold. These audio peaks are taken from the output stage and rectified to produce a negative bias that is fed back to the grids of the first audio stage. The input audio and output audio are both controllable by means of attenuators on the front panel. A panel meter is provided for metering three selectable internal circuits and two selectable external circuits. A self-contained power supply is included in the 26U-1.

4.2 AUDIO AMPLIFIER CIRCUITS.

Refer to the block diagram, figure 4-1. Audio enters the 26U-1 at terminals 11 and 12 of TB1, which connect to the INPUT LEVEL attenuator, AT1. The output of AT1 is fed through a 12-db pad to the 600-ohm primary of input transformer T1. The first audio stage, V1, a type GL-6386, is excited in push-pull from the secondary of T1. The plate voltage for V1 is obtained by a shunt circuit through a current-balancing control, R10. The audio output of V1 is transformer coupled to the grid of V2, the push-pull intermediate amplifier, a type 12AU7 dual triode. The output of V2 is resistance coupled to the push-pull output amplifier, a pair of 6V6GT tubes. The plate load for V3 and V4, the output tubes, is T3, a transformer with two secondary windings. One secondary winding, terminals 5 and 6, is employed in a negative feedback circuit to the cathodes of V2 to reduce distortion and improve frequency response characteristics of the amplifier. The other winding is the output winding and is connected to the OUTPUT LEVEL attenuator, AT2, through a 6-db pad. OUTPUT LEVEL attenuator AT2 contains a switch which bypasses the attenuator when the knob of the attenuator is operated to the cue (extreme ccw) position. When the attenuator is bypassed, the output of the amplifier is available at terminals 3 and 4. When the attenuator is operated to any other portion of its range, the output of the amplifier is taken from terminals 1 and 2 of TB1.

4.3 PEAK LIMITING CONTROL CIRCUITS.

The characteristics of V1, a type GL-6386 tube, are such that the gain of the tube can be varied by varying the bias to the control grids without generating appreciable distortion. The 26U-1 takes advantage

of this feature by using a 6AL5 dual diode tube, V5, to rectify the peak audio at the plates of the output tubes and then feeding the voltage thus obtained back to the grids of V1 as negative bias to reduce the gain of the amplifier during the periods of peak audio. The audio from the plates of the audio output tubes is coupled to the cathodes of the 6AL5 through capacitors C8 and C9. The cathode of the 6AL5 are biased with a fixed positive voltage from the regulated portion of the power supply to obtain a threshold below which the 6AL5 will not pass current. When the audio output level of the 6V6GT tubes goes above the threshold bias level, the 6AL5 conducts and rectifies the audio peaks. The gain control bias, obtained at the plates of the 6AL5, is fed to the grids of V1 through R36, the attack time variable resistor. The attack time constant is produced by capacitor C11 which also filters the audio ripple from the gain control bias. The release time of the gain control bias is adjusted by resistor R38 which bleeds the charge from capacitor C11 after the 6AL5 stops conducting.

4.4 POWER SUPPLY CIRCUITS.

The power supply uses a full-wave voltage doubler circuit. The combination plate and filament transformer T4 drives the half-wave silicon rectifiers CR1 and CR2. Capacitors C12 and C13 are part of the voltage-doubling circuit, and capacitor C3B along with inductor L1 filters the ripple from the direct current. Resistor R42 is a 10-ohm resistor used as a surge limiter. The full output of the power supply is applied to the plates and screens of the output tubes, V3 and V4. Regulated 150 volts is obtained by the use of resistor R39 and VR tube V6, a type OA2 gaseous regulator. This regulated 150-volt supply is used for the plates of V1 and for the threshold bias applied to V5. The threshold bias is reduced to proper value by the bleeder consisting of R41 and R43. Extra filtering and audio decoupling is obtained by capacitors C7, C3A, and C3C.

4.5 METERING CIRCUITS.

Meter M1 is a panel-mounted, rectifier-type meter calibrated in volume units (VU) and db gain reduction units. The meter is connected to three internal circuits, INPUT, G.R., and OUTPUT, and to two external circuits, G.R. EXTERNAL and EXTERNAL (audio), by the METER switch S1. When the meter is measuring audio, a meter multiplier, AT3, calibrated in volume units is connected to it. When the meter is used to measure gain reduction, the meter multiplier, AT2, is switched out of the circuit. Refer to figure 4-2. The VOLUME UNITS attenuator, AT3, extends the meter calibration in 2-vu steps so that the meter can indicate levels in the range of -16 VU to +27 VU and OFF.

SECTION IV
Principles of Operation

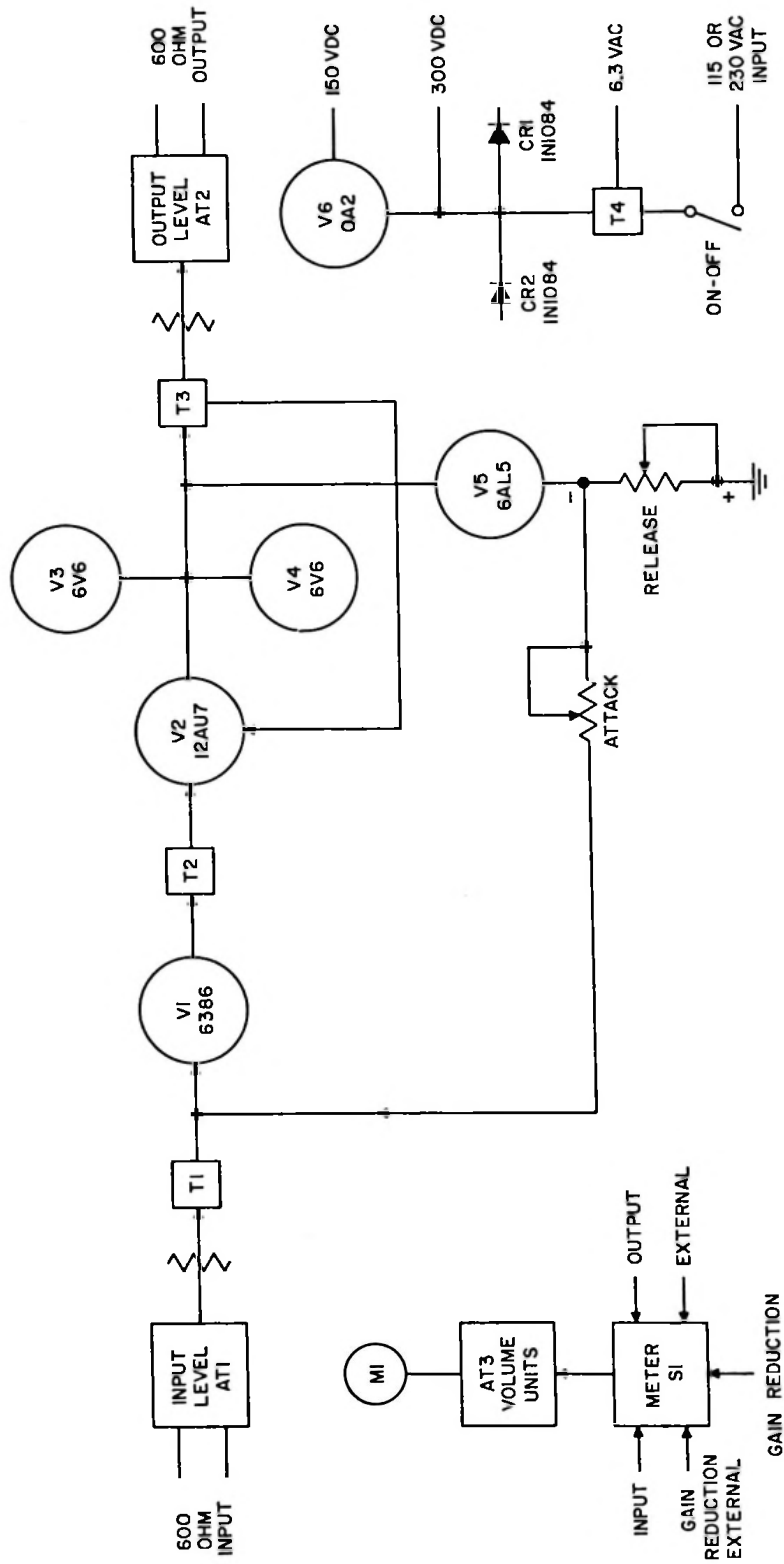

Figure 4-1. Peak Limiting Amplifier 26U-1, Block Diagram

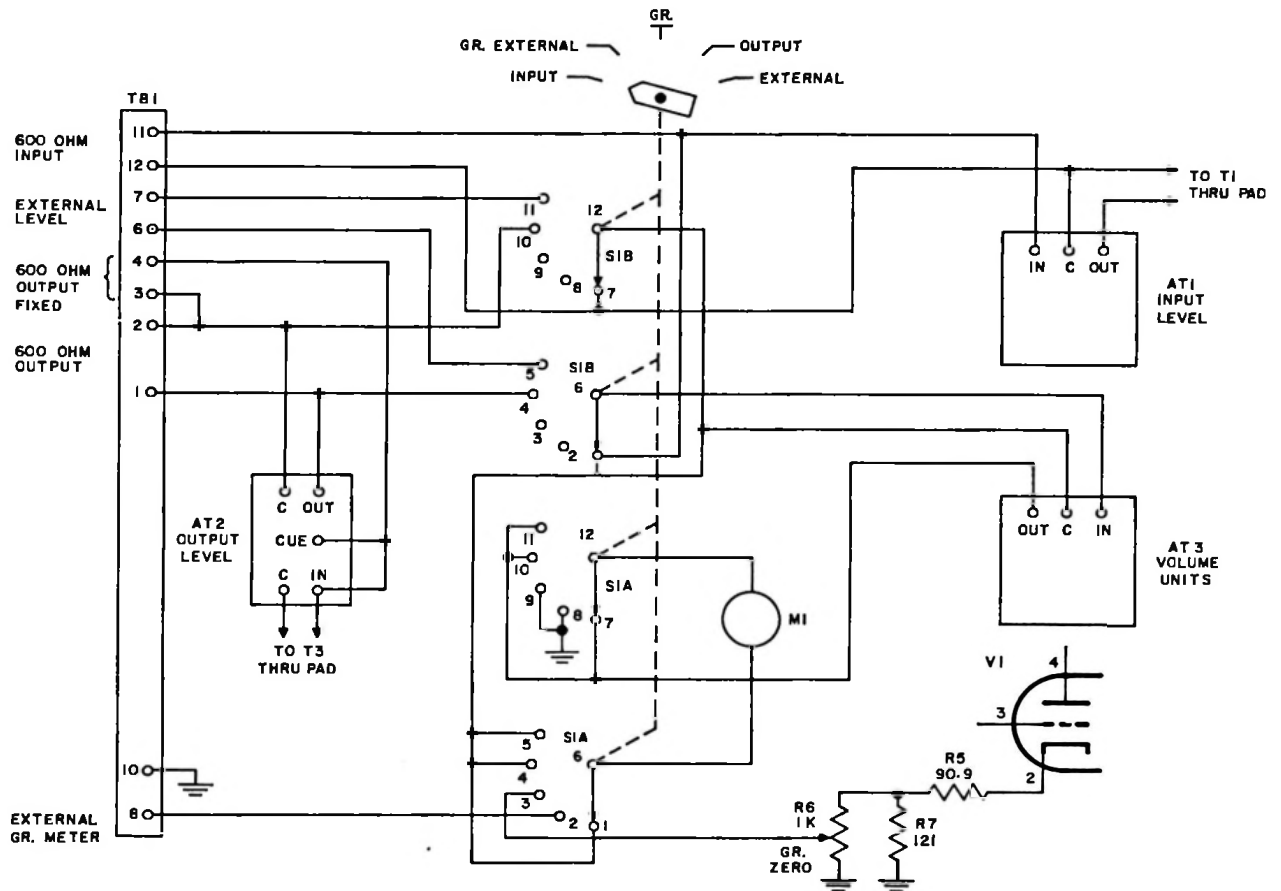

Figure 4-2. Metering Circuits, Simplified Diagram

SECTION V MAINTENANCE

5.1 OPERATOR'S CHECK.

- a. Turn on the equipment, and allow five minutes for stabilization.
- b. Turn the INPUT LEVEL control to off. Turn the METER switch to G.R.
- c. See that the voltage regulator tube, V6, is glowing. Failure of the voltage regulator tube to glow is an indication of a bad tube, low B+ voltage, or abnormal loading in the plate circuit of V1 or the threshold bias circuit of V5. If any of these conditions exist, almost certain malfunctioning of the 26U-1 will result.
- d. With no signal input to the 26U-1, adjust the G.R. ZERO control inside the unit until the meter indicates zero on the DB GAIN REDUCTION scale.
- e. Close the front panel, and perform steps c thru g of paragraph 2.4.1 of section II.

5.2 BENCH PERFORMANCE TEST.

The following procedure can be used to check the results of any service work done on the equipment or to check an equipment suspected of being faulty.

5.2.1 TEST EQUIPMENT REQUIRED.

The following test equipments or equivalents are required to perform the specified tests:

- a. Audio Oscillator, Hewlett-Packard 205G
- b. Attenuator Panel, Daven HA-740-B

- c. Attenuator Output Pad, 600-600 Ohms, 0 Db. Daven Type 7337
- d. VTVM
- e. A-C VTVM, Hewlett-Packard 400D
- f. Noise and Distortion Analyzer, General Radio 1932A
- g. Headphones, High Impedance
- h. Oscilloscope

5.2.2 TEST CONDITIONS.

Unless otherwise specified, all test should be performed under the following conditions:

- a. Line voltage, frequency and phase: 115 volts (or 230 volts if 26U-1 is so converted), 50/60 cps, single-phase.
- b. Ambient temperature: Normal studio ambient.
- c. Ambient humidity: Normal studio ambient.
- d. Ambient atmospheric pressure: Normal studio ambient.
- e. Shielding and isolation requirements: None.
- f. Operation duty cycle: Continuous.
- g. Warmup time: 5 minutes.
- h. Output terminated in a 600-ohm load.

5.2.3 INITIAL ADJUSTMENTS.

5.2.3.1 G.R. ZERO SETTING. Set the METER switch in the G.R. position, and with zero input signal, set G.R. ZERO control R6 for 0 reading on DB GAIN REDUCTION scale.

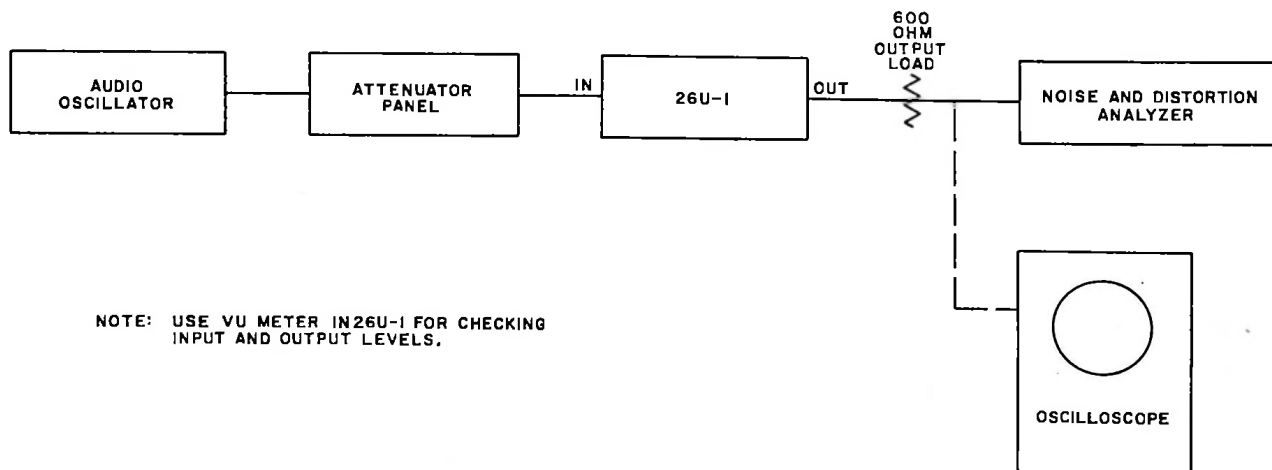

Figure 5-1. Test Setup, Block Diagram

5.2.3.2 G.R. BAL.

- a. Set OUTPUT LEVEL control to maximum attenuation.
- b. Set METER switch to INPUT.
- c. Set VOLUME UNITS attenuator to 8.
- d. Connect the audio oscillator to the input of the 26U-1 through the Daven attenuator panel with at least 10 db attenuation inserted. (See test setup, figure 5-1.)
- e. Set INPUT LEVEL control to off.
- f. Apply 1000 cps audio to the input of the 26U-1 until the meter indicates 0 VU (0 equals +8 vu when VOLUME UNITS attenuator is set at 8).
- g. Set the METER switch to G.R., and slowly advance the INPUT LEVEL control until threshold is reached (meter reading starts to indicate gain reduction).
- h. Set the METER switch to OUTPUT and the VOLUME UNITS attenuator to 8 vu. Advance the OUTPUT LEVEL control until the VU meter indicates 0 VU (0 equals +8 vu when VOLUME UNITS attenuator is set at 8).
- i. Switch out 2 or 3 db attenuation at the Daven attenuator, and note if the output meter has a downward deflection before rising.
- j. If the condition of step h is noted, R10, the G.R. BAL. potentiometer, is not set properly and should be readjusted to a point where no downward kick is present.
- k. Make the same check (step h) with a 10-db increase in input signal. If the setting of R10 has to be changed very much, find a compromise setting that will give a one-half db or less downward kick for either a 3- or 10-db increase in signal. If such a setting cannot be found, replace VI (6386) because the gain of the two sections does not remain uniform as the grid bias is raised.

An oscilloscope may be used to check balance if desired. Attach the oscilloscope to the amplifier output, and synchronize it to the 1000-cps input so several cycles can be observed. With the 26U-1 set

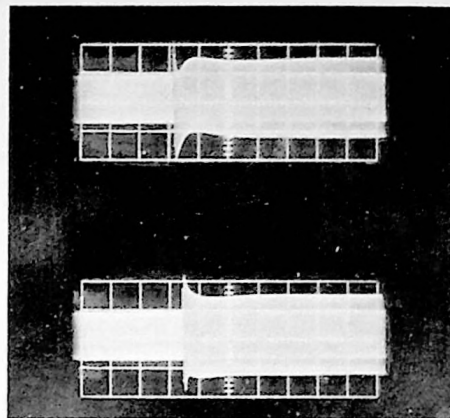

Figure 5-3. Peak Limiting Amplifier 26U-1, Unbalanced

on the verge of compression, remove 10 db of attenuation from the Daven attenuator panel, and observe the pattern. When the 26U-1 is balanced, the change in amplitude with increase will be uniform as shown in figure 5-2. If the 26U-1 is unbalanced, the change will shift and be irregular as shown in figure 5-3. While watching the attack time, switch 10 db of attenuation in and out. Set R10 for best point of balance. Figure 5-3 is a photograph of a 26U-1 unbalanced to both limits of R10. The input level was increased from 4 db below threshold to 6 db above threshold. Each division equals 50 milliseconds.

5.2.4 TEST PROCEDURE.

5.2.4.1 PLATE VOLTAGE. Measure the plate voltage between pin 4 of V4 and chassis when the line

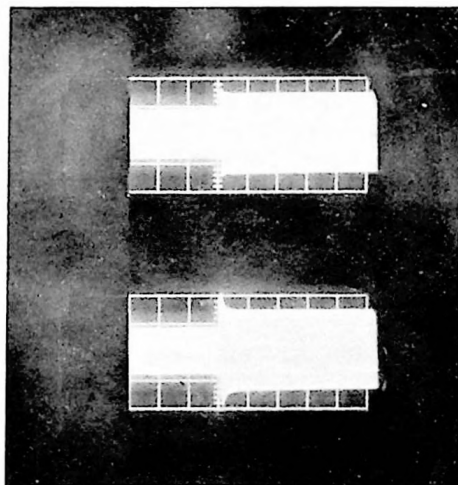

Figure 5-2. Peak Limiting Amplifier 26U-1, Attack Time

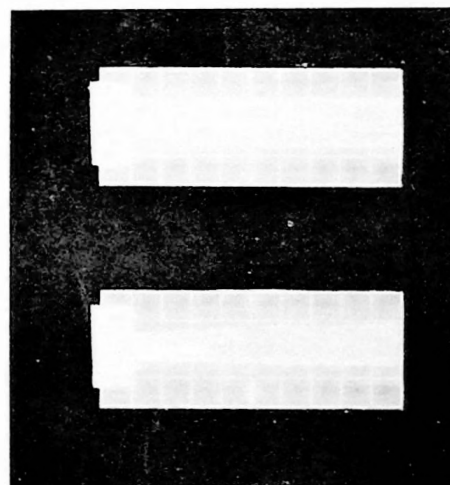

Figure 5-4. Peak Limiting Amplifier 26U-1, Release Time

SECTION V Maintenance

voltage is at specified value. The value of plate voltage should be not less than 285 volts and not more than 315 volts.

5.2.4.2 ATTACK AND RELEASE TIME. The attack and release time can be checked by using an oscilloscope and a 1000-cps input signal. Attach the oscilloscope to the output of the 26U-1, and synchronize it with the 1000-cps input signal. With the 26U-1 set on verge of compression, remove 10 db of attenuation from the Daven attenuator to observe the attack time. The attack time should be adjustable between 0.5 to 3.0 milliseconds with R36.

See figures 5-2 and 5-4 for illustrations of a typical unit for attack and release times. In figure 5-2, the top view was made with R36 set for fast attack time. The bottom view was made with R36 set for slow attack time. The photographs were made of the output level of a 26U-1 with input change from 4 db below threshold to 6 db into compression. Each division equals 50 milliseconds.

Figure 5-4 illustrates release time. In the top photograph R38 was set for fast release. In the bottom photograph, R38 was set for slow release. The photographs were made of the output level of a 26U-1, while the input level changed from 6 db above threshold to 4 db below threshold. Each division equals 1 second.

Insert 10 db attenuation with the Daven attenuator, and observe the time it takes for the wave form to return to its original level on the scope. This release time should be adjustable between 2.2 to 5.2 milliseconds for 63% recovery with R38.

5.2.4.3 DISTORTION MEASUREMENTS.

a. Adjust the audio input level to 3 db below the point of limiting at 1000 cps and hold constant as the following frequencies are checked for distortion: 50 cps, 1000 cps, and 15,000 cps. The distortion should not be more than 1-1/2% at 50 cps and not more than 1% at 1000 and 15,000 cps.

b. Repeat step a except adjust the input level to 10 db above the point of limiting. The distortion at all three frequencies should not exceed 1.5%.

5.2.4.4 NOISE LEVEL.

a. Disconnect the audio input to the 26U-1. Connect both input and output terminations to 600-ohm loads, and turn the INPUT LEVEL and OUTPUT LEVEL controls to full on (clockwise).

b. The noise level at the output should be not more than -50 dbm.

5.2.4.5 COMPRESSION RATIO.

a. Set the ATTACK (R36) and RELEASE (R38) time controls to S (slow).

b. Set the OUTPUT LEVEL attenuator to midrange, and adjust the INPUT LEVEL attenuator to just within the point of limiting as shown on the DB GAIN REDUCTION scale of the meter. Measure the compression ratio at 10 db increase above point of limiting and at 20 db increase above point of limiting. Compression ratio = $\frac{\text{input level increase}}{\text{output level increase}}$. At 10 db above verge of limiting, the compression ratio should be approximately 12 to 1. At 20 db above the verge of limiting, the compression ratio should be approximately 10 to 1.

5.2.4.6 FREQUENCY RESPONSE.

a. Run a standard frequency response after the input has been adjusted to a point 3 db below limiting for 1000 cps and maintained at that level for balance of frequencies. The response should be within ± 1.5 dbm from 1000 to 50 cps and from 1000 to 15,000 cps.

b. Repeat step a with the input set at 10 db above the verge of limiting. The response should be the same as listed for a.

5.2.4.7 GAIN.

a. Set both the INPUT LEVEL and the OUTPUT LEVEL controls to full clockwise rotation.

b. Feed audio into the 26U-1, but stay below limiting action as indicated by the DB GAIN REDUCTION scale.

c. Compute gain. The gain should be not less than 35 dbm and not more than 41 dbm.

5.3 MAINTENANCE.

5.3.1 RESISTANCE AND VOLTAGE MEASUREMENTS.

Table 5-1 gives the voltages and resistance measured at all important points in the circuits. Voltages are measured with power applied as in normal operation and with 50 cps input signal to cause 10 db limiting. All voltage readings are taken with the line voltage as specified (115 or 230 volts, depending upon the installation). All resistance measurements taken with no power applied. All measurements taken between specified terminal and ground.

5.3.2 RECTIFIER REPLACEMENT.

The silicon diodes used as power rectifiers in this equipment have very long service life; however, because of the comparative scarcity of these units, spares should be at hand. The rectifiers are polarized by means of a groove cut in the ferrule on one end of the rectifier. One end of the clip into which the rectifier fits is provided with a projection. Match the groove in the end of the rectifier with the projection on the clip when installing new rectifiers.

TABLE 5-1. RESISTANCE AND VOLTAGE MEASUREMENTS

TUBE	MEASUREMENT	PIN NUMBER								
		1	2	3	4	5	6	7	8	9
V1 (6386)	V D-C		0.9	-6.5	120		120	-6.5	0.9	
	V A-C	3.2		0.45	0.8		0.8	0.45		3.2
	Ohms	0.1	185	1.8 meg	22K		22K	1.8 meg	185	0.1
V2 12AU7	V D-C	172	0	6.6			172	0	6.6	
	V A-C	8.2	1.8	1.1	3.2	3.2	8.2	1.8	1.1	3.2
	Ohms	50K	9500	800	0.1	0.1	50K	9500	800	0.1
V3 6V6GT	V D-C			310	315	0			19	
	V A-C		3.2	80		8.0		3.2	2.9	
	Ohms		0.1	7500	7000	300K		0.1	470	
V4 6V6	V D-C			310	315	0			19	
	V A-C		3.2	80		8.0		3.2	2.9	
	Ohms		0.1	7500	7000	300K		0.1	470	
V5 6AL5	V D-C	90	-6.5			90		-6.5		
	V A-C	80	0.25	3.2	3.2	80		0.25		
	Ohms	600K	1.8 meg	0.1	0.1	600K		1.8 meg		
V6 OA2	V D-C		0			150				
	Ohms		0			1600				

NOTES:

1. Measurements made between each pin and ground.
2. Resistance measurements made with VOM.
3. Voltage measurements made with 50 cps input and 10 db limiting.
4. D-c measurements made with vtvm 11 meg input.
5. A-c measurements made with Hewlett-Packard 400D.



Disconnect primary power from the unit when changing rectifiers.

5.3.3 TUBE REPLACEMENT.

Best results are obtained with the 26U-1 when matched tubes are used in the output stage (V3 and V4). Select replacement tubes that are free from electrical and mechanical noises. Should the characteristics of the type 6386 (VI) change, a thump

might appear in the limiting action and be difficult to remove by adjustment of V10 (G.R. BAL.). Replace the tube, and adjust G.R. BAL. using the procedure given in paragraph 5.2.3.2.

5.3.4 METER LAMP REPLACEMENT.

The two lamps in the VU meter are accessible from the front. Both lamps are mounted on a bracket at the front of the meter case. Remove the screws at the edge of the meter face; remove the front of the meter case; replace the lamps with number 47, 6.3-volt, brown-bead, bayonet-base lamps; and replace the front.

SECTION VI PARTS LIST

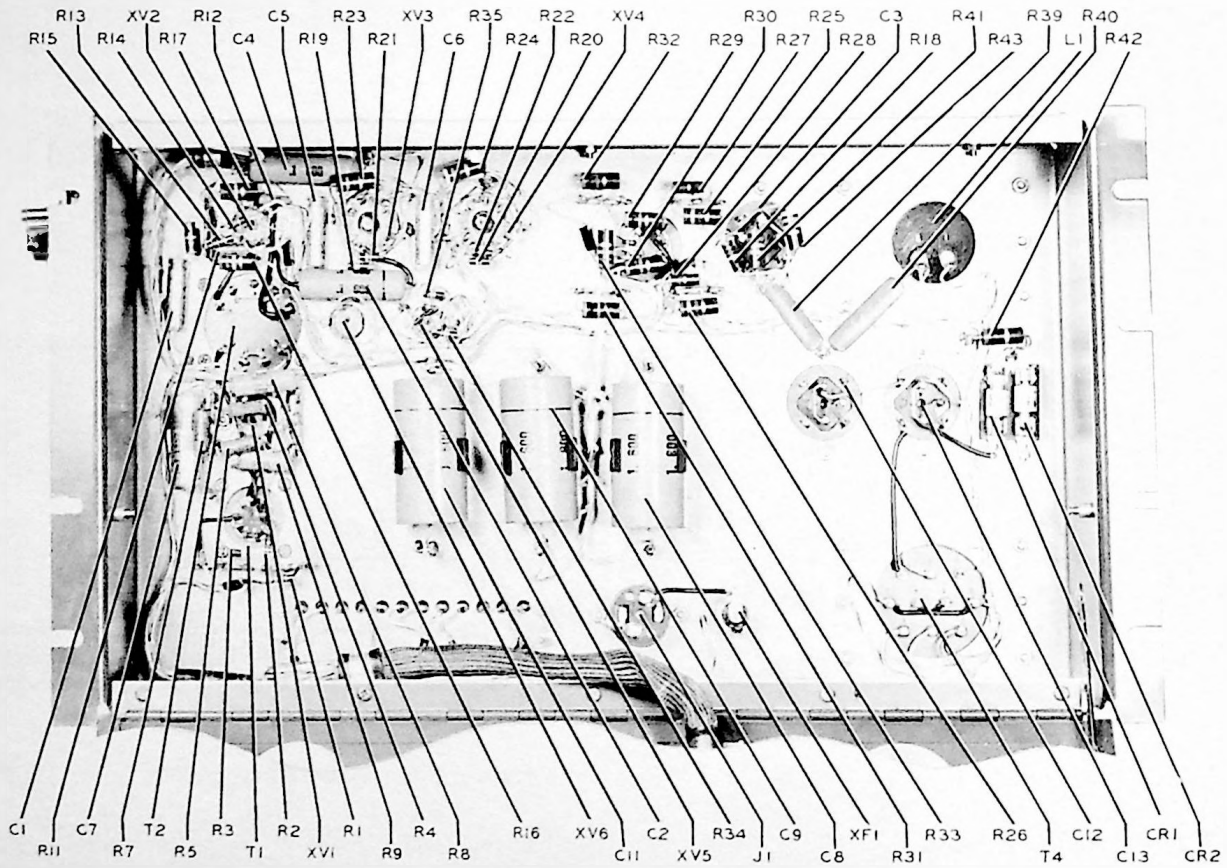

Figure 6-1. Peak Limiting Amplifier 26U-1, Front View, Panel Lowered

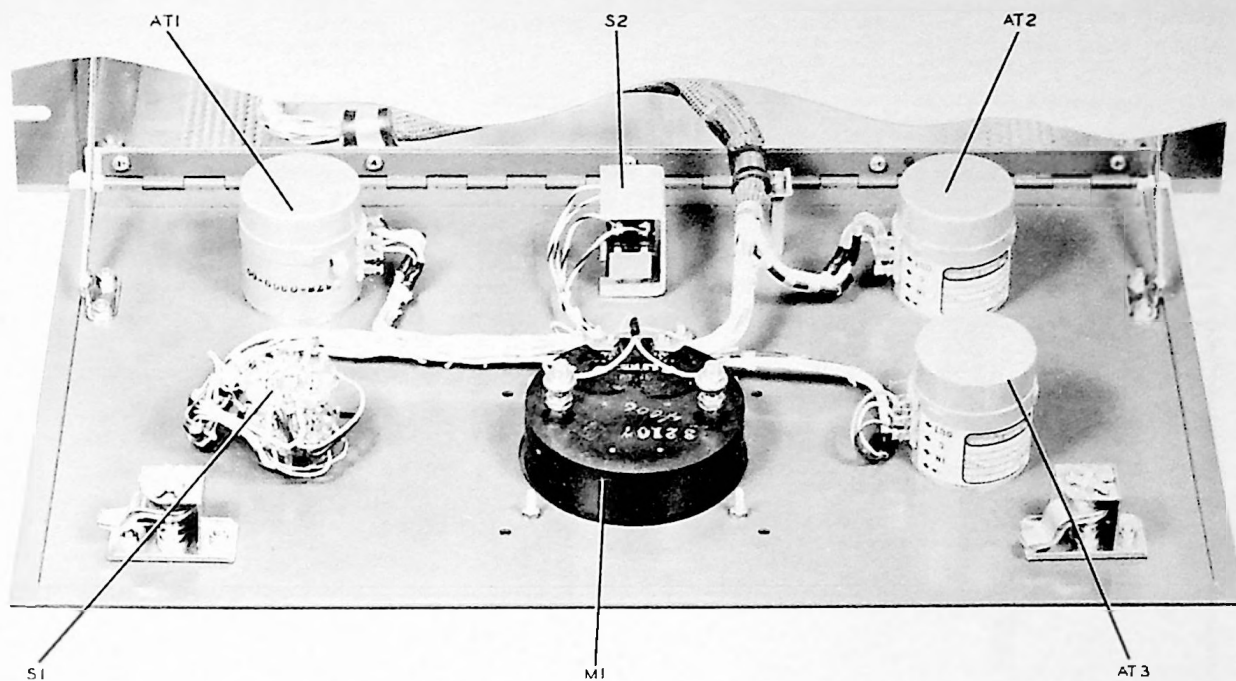

Figure 6-2. Peak Limiting Amplifier 26U-1, Inside Front Panel

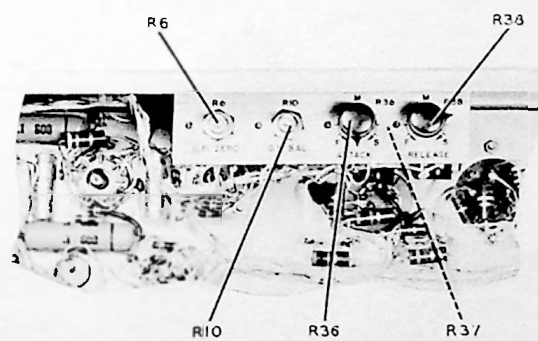

Figure 6-3. Peak Limiting Amplifier 26U-1,
Inside Control Panel

SECTION VI
Parts List

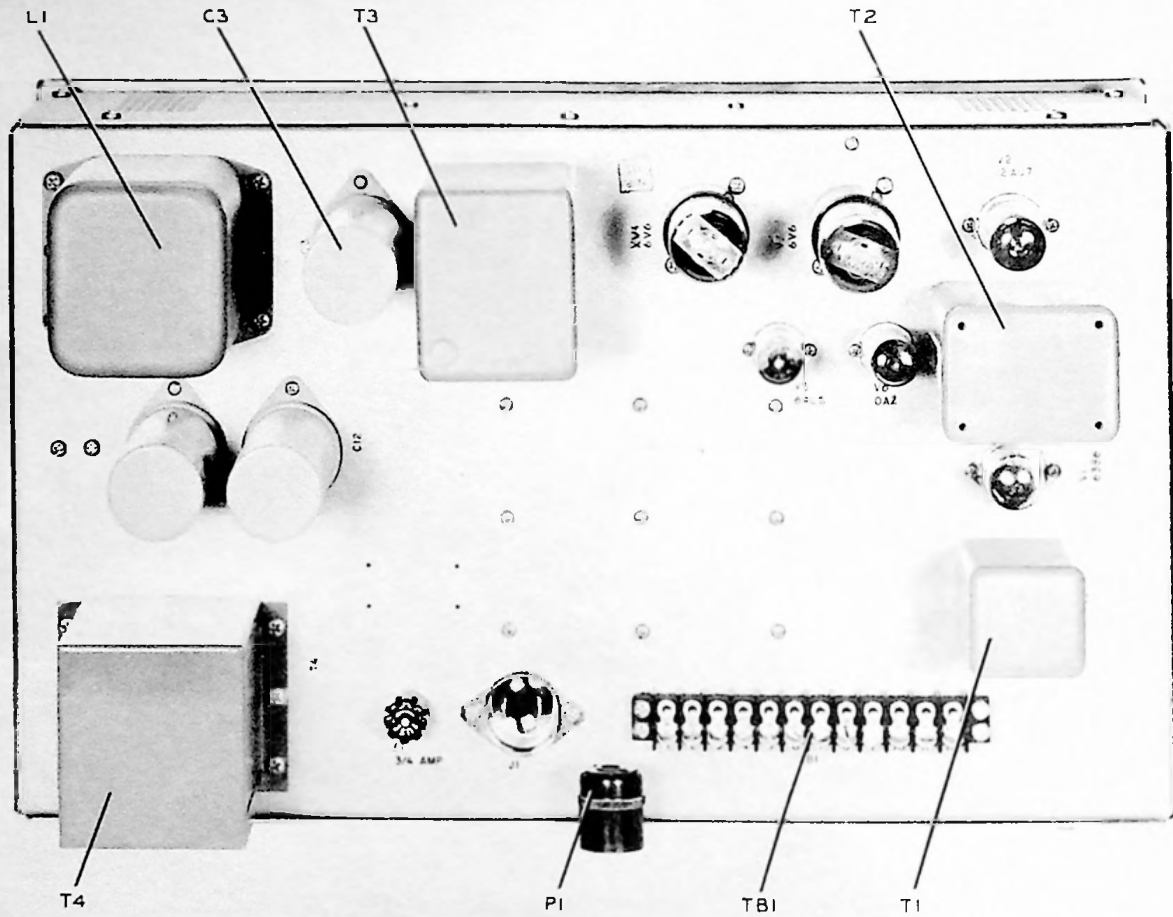

Figure 6-4. Peak Limiting Amplifier 26U-1, Rear View

Peak Limiting Amplifier 26U-1

ITEM	DESCRIPTION	COLLINS PART NUMBER
PEAK LIMITING AMPLIFIER 26U-1		522 0966 00
AT1	ATTENUATOR, VARIABLE: 600/600 ohms impedance, 20 steps, 2 db ea step except last, last step infinity, cw shaft rotation; Daven Co. no. 5407	378 0369 00
AT2	ATTENUATOR, VARIABLE: 600/600 ohm impedance, 20 steps, 2 db ea step except taper last three, cw shaft rotation; Daven Co. type LAQ350	378 0372 00
AT3	ATTENUATOR, VARIABLE: 7500 ohms input, 3900 ohms output, 12 steps, 2 db ea step, cw shaft rotation; Daven Co. type 350	378 0422 00
C1	CAPACITOR, FIXED, ELECTROLYTIC: 25 uf, 50 vdcw, minus 0% to plus 100%; Sprague no. 49682A	183 1356 00
C2	CAPACITOR, FIXED, PAPER DIELECTRIC: 0.1 uf plus 20% minus 10%, 12 vdcw; Sangamo type 30	931 0201 00
C3	CAPACITOR, FIXED, ELECTROLYTIC: triple section, 40 uf, 40 v, 8 uf, 450 v ea section, minus 10%, plus 50%; Sprague Electric	183 0183 00
C4	CAPACITOR, FIXED, PAPER DIELECTRIC: same as C2	931 0201 00
C5	CAPACITOR, FIXED, ELECTROLYTIC: same as C1	183 1356 00
C6	CAPACITOR, FIXED, ELECTROLYTIC: same as C1	183 1356 00
C7	CAPACITOR, FIXED, ELECTROLYTIC: 0.1 uf, 400 vdcw, ±10%; Sprague Electric	931 0299 00
C8	CAPACITOR, FIXED, PAPER DIELECTRIC: 1.0 uf plus 20% minus 10%, 1200 vdcw; Sangamo type 30	931 0206 00
C9	CAPACITOR, FIXED, PAPER DIELECTRIC: same as C8	931 0206 00
C10	NOT USED	
C11	CAPACITOR, FIXED, PAPER DIELECTRIC: same as C8	931 0206 00
C12	CAPACITOR, FIXED, ELECTROLYTIC: dual section, 40 uf at plus 25°C, minus 10% plus 75%, 450 vdcw; Sprague type 17D	183 0081 00
C13	CAPACITOR, FIXED, ELECTROLYTIC: same as C12	183 0081 00
CRI	SEMICONDUCTOR DEVICE, DIODE: type 1N1084; Sarkes-Tarzian 40M(M500)	353 1567 00
CR2	SEMICONDUCTOR DEVICE, DIODE: same as CRI	353 1567 00
F1	FUSE, CARTRIDGE: cylindrical, glass body, brass, nickel or bright alloy plated, 0.750 amp; Bussman Mfg. no. MDL 3/4	264 4270 00
J1	CONNECTOR, RECEPTACLE, ELECTRICAL: 2 male contacts, 10, 15 amps, 250, 125 v a-c or d-c, straight shape; G. E. no. 2711	368 3700 00
L1	REACTOR: 8 by inductance, 105 ma d-c, 100 ohms d-c resistance; Chicago Std. Trans.	668 0282 00
M1	METER, AUDIO LEVEL: measurement in volume units, db, and percent volts; -20 to plus 3 cw, 0 to 100 cw, plus 20 to 0 cw range of inscriptions; panel type, Stimpson Elec. type 142 Illum. with 2 202 324000 lamps	456 0052 00
O1	KNOB: setscrew type, 13/32 in. thk by 11/16 in. w by 27/32 in. lg over-all, black body; Harry Davies Moulding no. 1400	281 0089 00
O2	KNOB: setscrew type, black body, brass insert, 2 in. dia by 1-1/4 in. h; Molded Insulation type VIZC	281 0206 00
O3	KNOB: setscrew type, black body, brass insert, 1-7/16 in. dia by 7/8 in. h; Molded Insulation type VIZB	281 0210 00
P1	PLUG: AC; 2 female contacts, 10, 15 amps; G.E. 4317-1	368 0002 00
R1	RESISTOR, FIXED, COMPOSITION: 390 ohms ±5%, 1/2 w; MIL RC20GF391J	745 1334 00
R2	RESISTOR, FIXED, COMPOSITION: same as R1	745 1334 00
R3	RESISTOR, FIXED, COMPOSITION: 330 ohms ±5%, 1/2 w; MIL RC20GF331J	745 1330 00
R4	RESISTOR, FIXED, FILM: 196 ohms ±1%, 1/2 w; International Resistance type MDC	705 7562 00
R5	RESISTOR, FIXED, FILM: 90.9 ohms ±1%, 1/2 w; International Resistance	705 7546 00
R6	RESISTOR, VARIABLE, COMPOSITION: 1000 ohms ±20%, 2 w; Allen Bradley type J	380 0671 00
R7	RESISTOR, FIXED, FILM: 121 ohms ±1%, 1/2 w; International Resistance	705 7552 00
R8	RESISTOR, FIXED, FILM: 1,000,000 ohms ±1%, 1 w; MIL RN75B1004F	705 3259 00
R9	RESISTOR, FIXED, FILM: same as R8	705 3259 00
R10	RESISTOR, VARIABLE, COMPOSITION: same as R6	380 0671 00
R11	RESISTOR, FIXED, FILM: 17,800 ohms ±1%, 1/4 w; International Resistance type MDB	705 7156 00

ITEM	DESCRIPTION	COLLINS PART NUMBER
R12	RESISTOR, FIXED, FILM: same as R11	705 7150 00
R13	RESISTOR, FIXED, COMPOSITION: 270 ohms ±10%, 1/2 w; MIL RC20GF271K	745 1328 00
R14	RESISTOR, FIXED, COMPOSITION: same as R13	745 1328 00
R15	RESISTOR, FIXED, COMPOSITION: 1000 ohms ±10%, 1 w; MIL RC32GF102K	745 3352 00
R16	RESISTOR, FIXED, COMPOSITION: 22,000 ohms ±5%, 2 w; MIL RC42GF223J	745 5707 00
R17	RESISTOR, FIXED, COMPOSITION: same as R16	745 5707 00
R18	RESISTOR, FIXED, COMPOSITION: 2200 ohms ±10%, 1 w; MIL RC32GF222K	745 3366 00
R19	RESISTOR, FIXED, COMPOSITION: 0.22 megohms ±10%, 1/2 w; MIL RC20GF224K	745 1450 00
R20	RESISTOR, FIXED, COMPOSITION: same as R19	745 1450 00
R21	RESISTOR, FIXED, COMPOSITION: 100,000 ohms ±10%, 1/2 w; MIL RC20GF104K	745 1436 00
R22	RESISTOR, FIXED, COMPOSITION: same as R21	745 1436 00
R23	RESISTOR, FIXED, COMPOSITION: 1800 ohms ±10%, 2 w; MIL RC42GF182K	745 5663 00
R24	RESISTOR, FIXED, COMPOSITION: same as R23	745 5663 00
R25	RESISTOR, FIXED, COMPOSITION: 2700 ohms ±5%, 2 w; MIL RC42GF272J	745 5600 00
R26	RESISTOR, FIXED, COMPOSITION: same as R25	745 5600 00
R27	RESISTOR, FIXED, COMPOSITION: 1500 ohms ±5%, 1 w; MIL RC32GF152J	745 3358 00
R28	RESISTOR, FIXED, COMPOSITION: same as R27	745 3358 00
R29	RESISTOR, FIXED, COMPOSITION: 100 ohms ±5%, 2 w; MIL RC42GF101J	745 5609 00
R32		
R33	RESISTOR, FIXED, COMPOSITION: 820 ohms ±5%, 2 w; MIL RC42GF821J	745 5648 00
R34	RESISTOR, FIXED, COMPOSITION: 0.56 megohms ±10%, 1/2 w; MIL RC20GF564K	745 1468 00
R35	RESISTOR, FIXED, COMPOSITION: same as R34	745 1468 00
R36	RESISTOR, VARIABLE, COMPOSITION: 25,000 ohms ±20%, 2 w; Allen-Bradley type J	380 0664 00
R37	RESISTOR, FIXED, COMPOSITION: 1.8 megohms ±10%, 1/2 w; MIL RC20GF185K	745 1489 00
R38	RESISTOR, VARIABLE, COMPOSITION: 5,000,000 ohms ±20%, 2 w; Allen-Bradley type J	380 0681 00
R39	RESISTOR, FIXED, COMPOSITION: 470 ohms ±10%, 2 w; MIL RC42GF417K	745 5638 00
R40	RESISTOR, FIXED, WIRE WOUND: 4000 ohms ±10%, 10 w; Resistor Inc.	710 1442 00
R41	RESISTOR, FIXED, COMPOSITION: same as R16	745 5707 00
R42	RESISTOR, FIXED, COMPOSITION: 10 ohms ±10%, 2 w; MIL RC42GF100K	745 5568 00
R43	RESISTOR, FIXED, COMPOSITION: 47,000 ohms ±5%, 2 w; MIL RC42GF473J	745 5721 00
S1	SWITCH, ROTARY: 2 section, 4 pole, 5 position, 24 fixed contacts, 4 moving contacts, Oak Mfg type F	259 0885 00
S2	SWITCH, TOGGLE: dpst; 2 positions, 30 amps; JAN ST52K	266 3057 00
T1	TRANSFORMER, AUDIO FREQUENCY: 600 ohms pri, 60,000 ohms sec; Audio Development A9956	667 0211 00
T2	TRANSFORMER, AUDIO FREQUENCY: pri 30,000 ohms zero ma; sec 68,000 ohms, zero ma; 1000 rms test voltage pri and sec; United Transformer	667 0894 00
T3	TRANSFORMER, AUDIO FREQUENCY: 9000 ohms pri; 600 ohms sec; Audio Development type A9656	667 0222 00
T4	TRANSFORMER, POWER, STEP-DOWN AND STEP-UP: pri 115 v, 115; sec 150 v tapped at 135 v, 6.3 v ct; Chicago Std. Trans.	662 0277 00
V1	ELECTRON TUBE: type 6386; G.E. type 6386	253 0015 00
V2	ELECTRON TUBE: twin triode, type 12AU7; RCA	255 0199 00
V3	ELECTRON TUBE: beam, type 6V6GT; RCA type 6V6GT	255 0021 00
V4	ELECTRON TUBE: same as V3	255 0021 00
V5	ELECTRON TUBE: twin diode rectifier, type 6AL5; G.E. type 6AL5	257 0018 00
V6	ELECTRON TUBE: OA2 voltage regulator; RCA OA2	257 0052 00
XF1	FUSEHOLDER: extractor post type; 250 v, 15 amp, 0.690 in. dia by 1.672 in. lg over-all; LittDefuse no. 342003	265 1023 00
XV1	SOCKET, ELECTRON TUBE: 9 C miniature, top mig tube socket w/o shield base; plastic MFE; Cinch Mfg.	220 1274 00
XV2	SOCKET, ELECTRON TUBE: same as XV1	220 1274 00
XV3	SOCKET, ELECTRON TUBE: 8 pin octal type contact, plastic body; Sylvania Elec. Prod. Inc.	220 1121 00
XV4	SOCKET, ELECTRON TUBE: same as XV3	220 1121 00
XV5	SOCKET, ELECTRON TUBE: 7 C miniature top mig tube socket w/o shield base, ceramic MFE; Cinch Mfg.	220 1152 00
XV6	SOCKET, ELECTRON TUBE: same as XV5	220 1152 00

SECTION VII ILLUSTRATIONS

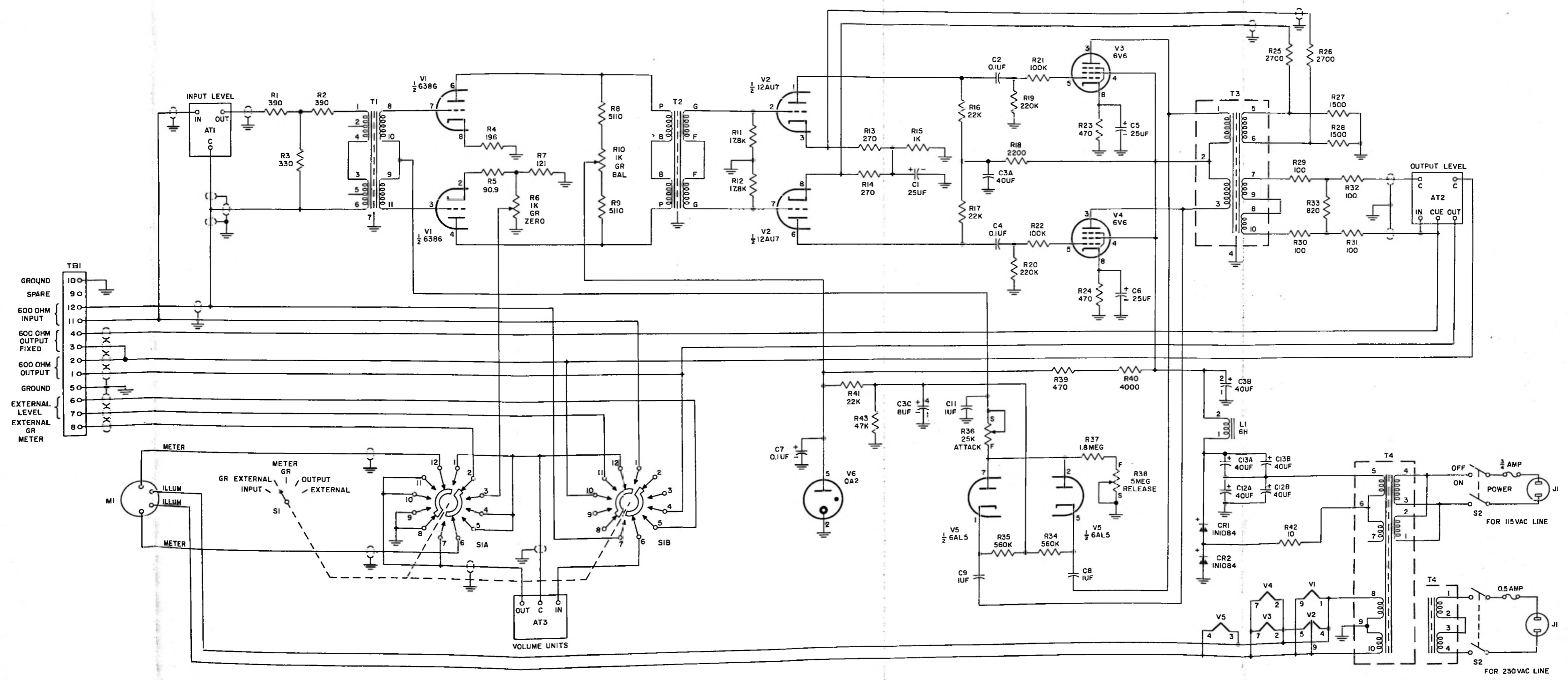
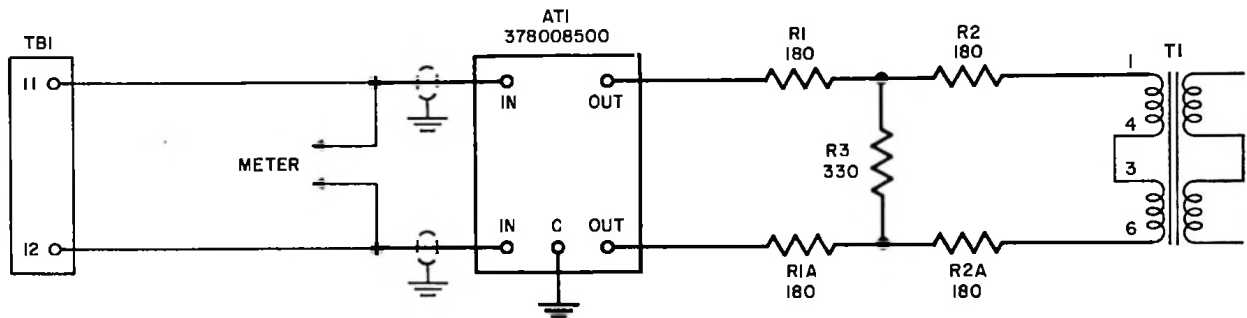
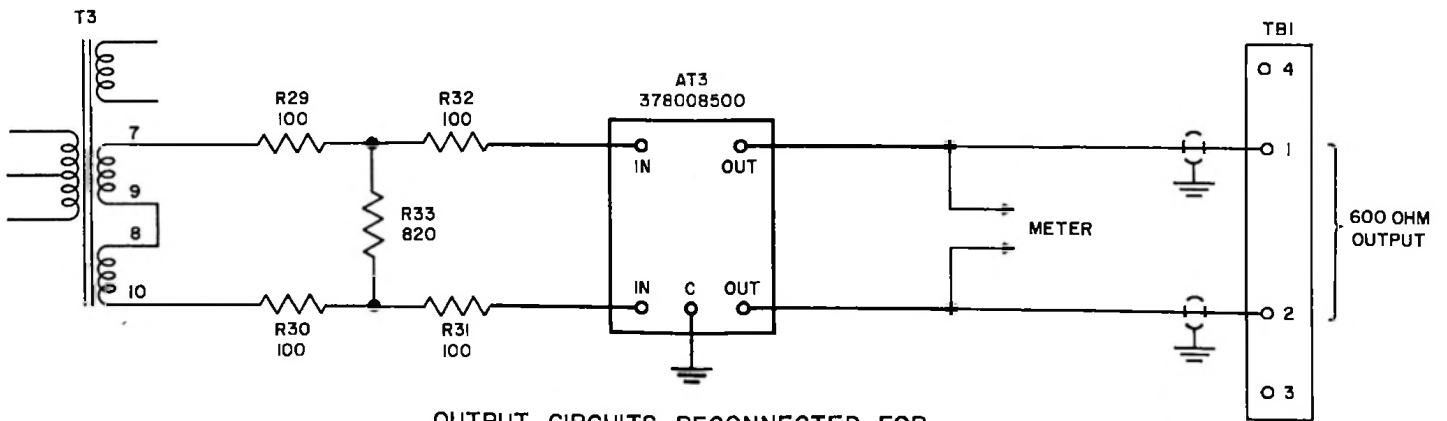

Figure 7-1. Peak Limiting Amplifier 26U-1, Schematic Diagram



INPUT CIRCUITS RECONNECTED
FOR BALANCED INPUT



OUTPUT CIRCUITS RECONNECTED FOR
ADJUSTABLE BALANCED OUTPUT

Figure 7-2. Conversion to Balanced Input and Output

Electrical Wire Code

EXAMPLES:

DA 92	UNSHIELDED WIRE, POLYVINYL, NO. 22 AWG, WHITE WITH A RED TRACER	<u>D</u> Type of Wire	<u>A</u> Size of Wire	<u>9</u> Color of Body	<u>2</u> Color of Tracers	
DAS 9123	SHIELDED WIRE (SINGLE) POLYVINYL, NO. 22 AWG, WHITE BODY WITH BROWN, RED AND ORANGE TRACERS	<u>D</u> Type of Wire	<u>A</u> Size of Wire	<u>S</u> Shielded	<u>9</u> Color of Body	<u>123</u> Color of Tracers
DASJ (9) (92)	SHIELDED AND JACKETED WIRE (MULTIPLE), POLYVINYL, NO. 22 AWG, WHITE AND WHITE WITH RED TRACER	<u>D</u> Type of Wire	<u>A</u> Size of Wire	<u>SJ</u> Shielded and Jacketed	<u>(9)</u> First Conductor	<u>(92)</u> Second Conductor
A2A 91	UNSHIELDED WIRE, IRRADIATED POLYOLEFIN, NO. 22 AWG, WHITE WITH BLACK TRACER	<u>A2</u> Type of Wire	<u>A</u> Size of Wire	<u>9</u> Color of Body	<u>1</u> Color of Tracer	

TYPE OF WIRE CODE		SIZE OF WIRE		COVERING OF WIRE	COLOR CODE	
CODE	DESCRIPTION	CODE	SIZE		CODE	TYPE
A	Cotton Braid Over Plastic	A	No. 22 AWG		0	Black
A2	Irradiated Modified Polyolefin, (300 Volts)	B	No. 20		1	Brown
A3	Irradiated Modified Polyolefin, (600 Volts)	C	No. 18		2	Red
A4	Irradiated Modified Polyolefin, (1000 Volts)	D	No. 16		3	Orange
A5	Irradiated Modified Polyolefin, (3000 Volts)	E	No. 14		4	Yellow
B	Buswire, Round Tinned	F	No. 12		5	Green
C	Polyvinyl Chloride, MIL-W-16878, Type B (600 Volts) (No. 20-18-16)	G	No. 10		6	Blue
D	Polyvinyl Chloride, MIL-W-16878, Type B (600 Volts) (No. 22-26-28)	H	No. 8		7	Violet
E	Vinyl, MIL-W-5086, Type I (600 Volts)	J	No. 6		8	Gray (Slate)
E2	Vinyl, MIL-W-5086, Type II (600 Volts) (No. 22-12) Note 1	K	No. 4		9	White
E3	Vinyl, MIL-W-5086, Type II (600 Volts) (No. 0000-10) Note 2	L	No. 2		a	Clear
E4	Vinyl, MIL-W-5086, Type III (600 Volts) (No. 12-22) Note 3	M	No. 1		b	Tan
E5	Vinyl, MIL-W-5086, Type III (600 Volts) (No. 0000-10) Note 4	N	No. 0		c	Pink
G		P	No. 00		d	Maroon
H	Kel-F (Monochlorotrifluoroethylene)	Q	No. 000		e	Light Green
I	Not Available	R	No. 0000	S	f	Light Blue
J		T	No. 28			
K	Neon Sign Cable (15,000 Volts)	V	No. 26	SJ		
L	Silicone, MIL-W-16878, Type FF (600 Volts)	W	No. 24			
L2	Silicone, MIL-W-16878, Type FFW (1000 Volts)	X	No. 19			
L3	Silicone, Non-MIL (5000 Volts)	Y	No. 30			
L4	Silicone, Non-MIL (10,000 Volts)	Z				
L5	Silicone, Non-MIL (15,000 Volts)					
M						
N	Single Conductor Stranded (Non-Rubber)					
O	Not Available					
P	Single Conductor Stranded (Rubber Covered)					
Q						
R	Polyvinyl Chloride, MIL-W-16878, Type C (1000 Volts)					
S	Not Available					
T	Teflon (TFE), MIL-W-16878, Type E (600 Volts) Stranded					
U	Not Available					
V	Polyvinyl Chloride, MIL-W-16878, Type D (3000 Volts)					
W	Teflon (TFE), MIL-W-16878, Type EE (1000 Volts)					
X	Teflon (TFE), MIL-W-16878, Type ET (250 Volts)					
X2	Teflon (FEP), MIL-W-16878, Type K (600 Volts)					
X3	Teflon (FEP), MIL-W-16878, Type KT (250 Volts)					
X4	Teflon (TFE), Non-MIL (3000 Volts)					
Y	Telephone Type, Polyvinyl					
Y1	Teflon (TFE), Non-MIL; Solid Conductor					
Z	Telephone Type, Braided Yarn					

- Note 1 - Extruded nylon over fiber glass braid.
- Note 2 - Braided, lacquered nylon over fiber glass braid.
- Note 3 - Extruded nylon over secondary vinyl over fiber glass over primary vinyl.
- Note 4 - Lacquered extruded nylon over secondary vinyl over fiber glass over primary vinyl.

