

*Scotty S.*

# Collins

## INSTRUCTION BOOK

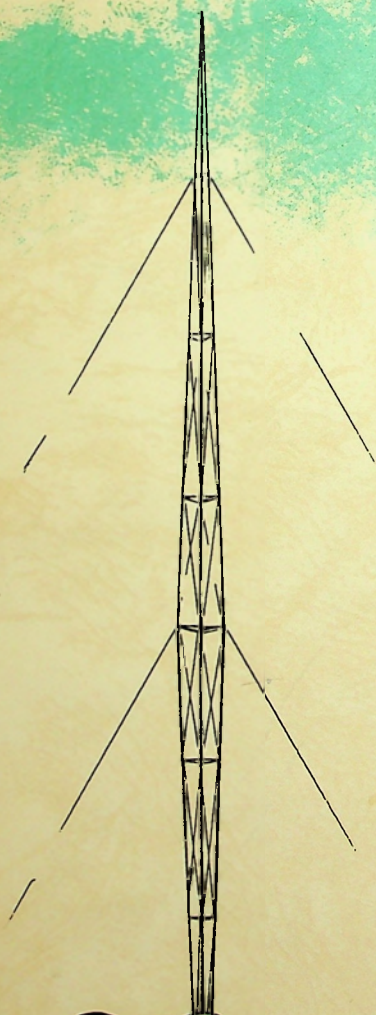

ATC

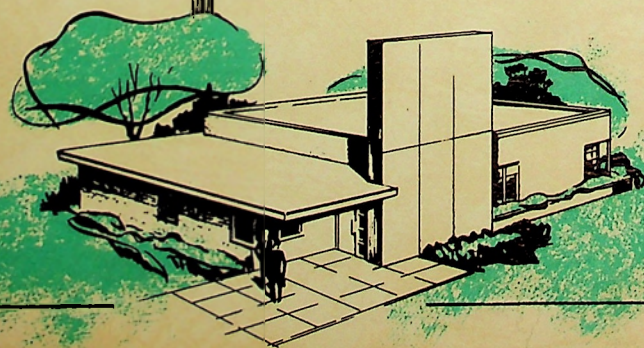

COLLINS RADIO COMPANY

## GUARANTEE

The equipment described herein is sold under the following guarantee:

Collins agrees to repair or replace, without charge, any equipment, parts, or accessories which are defective as to design, workmanship or material, and which are returned to Collins at its factory, transportation prepaid, provided

### 6 MOS.

- (a) Notice of the claimed defect is given Collins within ~~one (1) year~~ from date of delivery and goods are returned in accordance with Collins' instructions.
- (b) Equipment, accessories, tubes, and batteries not manufactured by Collins or from Collins' designs are subject to only such adjustments as Collins may obtain from the supplier thereof.
- (c) No equipment or accessory shall be deemed to be defective if, due to exposure or excessive moisture in the atmosphere or otherwise after delivery, it shall fail to operate in a normal or proper manner.

Collins further guarantees that any radio transmitter described herein will deliver full radio frequency power output at the antenna lead when connected to a suitable load, but such guarantee shall not be construed as a guarantee of any definite coverage or range of said apparatus.

The guarantee of these paragraphs is void if equipment is altered or repaired by others than Collins or its authorized service center.

No other warranties, expressed or implied, shall be applicable to any equipment sold hereunder, and the foregoing shall constitute the Buyer's sole right and remedy under the agreements in this paragraph contained. In no event shall Collins have any liability for consequential damages, or for loss, damage or expense directly or indirectly arising from the use of the products, or any inability to use them either separately or in combination with other equipment or materials, or from any other cause.

**HOW TO RETURN MATERIAL OR EQUIPMENT.** If, for any reason, you should wish to return material or equipment, whether under the guarantee or otherwise, you should notify us, giving full particulars including the details listed below, insofar as applicable. If the item is thought to be defective, such notice must give full information as to nature of defect and identification (including part number if possible) of part considered defective. (With respect to tubes we suggest that your adjustments can be speeded up if you give notice of defect directly to the tube manufacturer.) Upon receipt of such notice, Collins will promptly advise you respecting the return. Failure to secure our advice prior to the forwarding of the goods or failure to provide full particulars may cause unnecessary delay in handling of your returned merchandise.

**ADDRESS:**

Collins Radio Company  
Sales Service Department  
Cedar Rapids, Iowa

**INFORMATION NEEDED:**

- (A) Type number, name, and serial number of equipment
- (B) Date of delivery of equipment
- (C) Date placed in service
- (D) Number of hours of service
- (E) Nature of trouble
- (F) Cause of trouble if known
- (G) Part number (9 or 10 digit number) and name of part thought to be causing trouble
- (H) Item or symbol number of same obtained from parts list or schematic
- (I) Collins' number (and name) of unit sub-assemblies involved in trouble
- (J) Remarks

**HOW TO ORDER REPLACEMENT PARTS.** When ordering replacement parts, you should direct your order as indicated below and furnish the following information insofar as applicable. To enable us to give you better replacement service, please be sure to give us complete information.

**ADDRESS:**

Collins Radio Company  
Sales Service Department  
Cedar Rapids, Iowa

**INFORMATION NEEDED:**

- (A) Quantity required
- (B) Collins' part number (9 or 10 digit number) and description
- (C) Item or symbol number obtained from parts list or schematic
- (D) Collins' type number, name, and serial number of principal equipment
- (E) Unit sub-assembly number (where applicable)

INSTRUCTION BOOK  
AUTOMATIC TAPE CONTROL

(Recording Amplifier - A-190 and A-150)

(Playback Unit - P-190 and P-150)

(Automatic Switcher - AMS-3 and AMS-4)

Manufactured for

COLLINS RADIO COMPANY  
Cedar Rapids, Iowa

by

AUTOMATIC TAPE CONTROL, INC.  
209 E. Washington Street  
Bloomington, Illinois

TABLE OF CONTENTS

Section 1  
GENERAL DESCRIPTION

- 1.1 General
- 1.2 Definitions
- 1.3 Unpacking

Section 2  
PLAYBACK AND RECORD UNITS

- 2.1 Installation
- 2.2 Operation
- 2.3 Maintenance
- 2.4 Specific Correction Adjustments

Section 3  
AUTOMATIC SWITCHER

- 3.1 Installation
- 3.2 Operation
- 3.3 Maintenance

Section 4  
REMOTE CONTROL PANELS

- 4.1 Installation
- 4.2 Operation
- 4.3 Maintenance

Section 5  
CARTRIDGES

- 5.1 Operation
- 5.2 Loading
- 5.3 Maintenance
- 5.4 Illustrations of Cartridges



Section 6  
PARTS LIST

- 6.1 Playback Unit P190 and P150
- 6.2 Program Amplifier
- 6.3 Cue Control Amplifier/Oscillator
- 6.4 Recording Amplifier A190 and A150
- 6.5 Automatic Switcher AMS-3 and AMS-4

Section 7  
ILLUSTRATIONS

- 7-1 Playback Parts Arrangement - Front View
- 7-2 Playback Parts Arrangement - Top View
- 7-3 Playback Parts Arrangement - Bottom View
- 7-4 Playback Parts Arrangement - Side View
- 7-5 Playback Parts Arrangement - Side View
- 7-6 Plug-in Components
- 7-7 Amplifier Parts Arrangement - Front View
- 7-8 Amplifier Parts Arrangement - Rear View
- 7-9 Amplifier Parts Arrangement - Bottom View
- 7-10 Amplifier Parts Arrangement - Top View
- 7-11 Switcher Parts Arrangement - Top View
- 7-12 RC-P Remote Control Panel
- 7-13 RC-R Remote Control Panel
- 7-14 RC-PR Remote Control Panel

Section 8  
SCHEMATICS

- 8-1 Automatic Tape Control Record/Playback
- 8-2 Automatic Tape Control Playback
- 8-3 Automatic Switcher

## SECTION 1

## GENERAL DESCRIPTION

## 1.1 GENERAL

Automatic Tape Control records and plays back on lubricated magnetic tape enclosed in a plastic cartridge. In control room operation, one commercial announcement or production aid is recorded on each cartridge. Automatic Tape Control and the associated cartridges should be considered as a specific method of reproducing tape recorded announcements much as transcription turntables are utilized for the playback of electrical transcriptions and phonograph records. In cases where several announcements, opening and closing themes, or other such information may be reproduced in the same sequence at all times, more than one announcement or production aid may be recorded on a cartridge. This method of recording provides for exact sequential playback of the recorded information.

Automatic Tape Control equipment consists of two basic units; the Playback Unit (P-190 or P-150) and the Recording Amplifier (A-190 or A-150). To record on tape cartridges, a Recording Amplifier must be connected to a Playback Unit. The Recording Amplifier may be plugged into any Playback Unit to accomplish the recording function. The Playback Unit is designed for reproducing tape cartridges and each unit is complete and ready to feed audio into any audio console. Playback Units may be installed in appropriate multiples in the main control area where the equipment is readily available to the operator for playback on-the-air.

Automatic Tape Control provides for an unlimited quantity of recorded production material. There is no limit to the number of cartridges that can be recorded and retained in the control room available for immediate use. Absolutely no threading or cueing time is required with Automatic Tape Control. Three sizes of cartridges are available for Automatic Tape Control units providing from 40 seconds to 31 minutes of recording time.

## 1.2 DEFINITIONS

- P-150 - 15" Panel Playback Unit
- P-190 - 19" Panel Playback Unit
- A-150 - 15" Panel Recording Amplifier
- A-190 - 19" Panel Recording Amplifier
- AMS-3 - AMS-3 will automatically switch a maximum of three playbacks to one input.
- AMS-4 - AMS-4 will switch a maximum of four machines.
- RC-R - 3 Push Button Control Panel - (Start-Record Set-Stop)
- RC-P - 3 Push Button Remote Control Panel - (Start-Start-Start)
- RC-RP - 6 Push Button Remote Control Panel - (Start-Start-Start) and (Start-Record Set-Stop)

## 1.3 UNPACKING

To avoid damage to the equipment, use caution when unpacking. All units should be inspected carefully. Check for loose screws and bolts. Inspect equipment as much as possible before application of power. Examine cables and wiring and make sure that all connections are tight and clear of each other and of the chassis. Claims for damage should be filed promptly with the carrier.

## SECTION 2

PLAYBACK AND RECORD  
UNITS

## 2.1 INSTALLATION

PLAYBACK UNITS -- Connect a shielded pair of wires from the 600 ohm output terminals of the Playback Unit to the selected console input terminals. The shield should be connected to the Playback Unit terminal G and to the console common ground. The AC cord is then connected to a source of 115 volt - 60 cycle power.

RECORD UNIT -- Install either above or below the Playback Unit in cabinet or rack. Remove the 10-pin male plug (P101) from the back of the Playback Unit. Insert one end of the supplied cord which has a 10-pin male plug at each end into the playback unit. The other end is inserted in the associated socket (S403) on the back of the Record Unit. Remove the pin plug from the program amplifier jack (J102) which is located adjacent to the plug-in program amplifier. Insert this pin plug in the jack marked "head" on the recording amplifier. Install the second supplied patch cord, which has a pin plug on each end, between the jack marked amplifier on the recording unit and the jack marked "program" (J102) on the Playback Unit.

Connect a shielded pair of wires from the desired recording source (0 to 8VU-600 ohms) to the 600 ohm input terminals on the back of the record unit and to a common ground at the source.

Retain the removed 10-pin plug (P101) for later use in case you wish to convert back to a Playback Unit only status.

## 2.2 OPERATION

RECORD UNIT -- Turn on AC power switch and allow tubes to come to operating temperature. Insert cartridge in the right hand side of the slot. A guide is provided to guide the motion of the cartridge into proper contact with the heads. The "Ready" light will be illuminated if the cartridge has been properly inserted.



## 2.2 OPERATION (cont'd)

Push the "Record-Set" button on the Recording Amplifier Unit. The "Record" light will be illuminated and the operator can adjust his gain control with reference to the VU meter on the amplifier panel. Normal recording level should peak zero.

To start the recording operation, depress the "Start" button. The function lights change immediately from "Ready" to "Run". At the time the "Run" light is illuminated the recording of program material should be started. The sooner program audio is fed into the Recording Unit after the "Run" light is illuminated, the tighter the cue will be.

At the start of the recording process, when the "Start" button is depressed, a tone burst is automatically recorded on the bottom half of the tape. The program information is recorded on the top half of the tape. After the tone burst has been recorded, the tone generator is automatically converted to a tone amplifier which actuates the stop mechanism upon the reception of the tone signal. Thus the original tone burst controls the position of the tape for playback. After the equipment is automatically stopped, the "Run" light returns to the "Ready" position and "Record-Set" light goes out, indicating the unit has automatically changed from the record to the playback position.

When making a recording, after the program information has been recorded on the cartridge, the mechanism should be permitted to continue running until the tone burst actuates the stop function. The cartridge should not be stopped manually because in that circumstance the announcement is not properly cued for the next playback.

When desiring to record more than one program on a single cartridge, the "Stop" button is depressed immediately on the finish of the first recorded programming causing the tape machine to stop. The "Run" light returns to the "Ready" position and the "Record-Set" light goes out, indicating the unit has automatically changed from record to playback position. Prior to beginning the second program on the same cartridge, the "Record-Set" button must again be depressed and the process repeated as for the first program. This process can be repeated until the tape cycle has been run. Caution should be used not to over-run the actual length of tape in the cartridge as the mechanism will automatically stop at the original tone burst. The playback section will double as a playback unit as described below.

## 2.2 OPERATION (cont'd)

PLAYBACK UNIT -- When the AC power switch has been turned on and the unit has been warmed up and the recorded cartridge has been properly inserted in the right side of the slot, the "Ready" light is illuminated indicating the unit is ready to reproduce on the air. When the "Start" button is depressed the tape will start moving across the playback head immediately, reproducing the program until the tone burst stops the equipment either at the original tone burst or that of the next program on the same cartridge. In either event the cartridge is recued and ready for the next playback. It is possible to reproduce program information from a cartridge on any Automatic Tape Control Playback or Record/Playback machine.

## 2.3 MAINTENANCE

PRESSURE ROLLER ADJUSTMENT -- Remove head cover pan and grill screen from right side of machine. Check pressure roller and capstan to be sure they are free of foreign matter. By hand, press solenoid plunger and linkage assembly to bottom of stroke thereby bringing pressure roller up to capstan. If adjustment is correct, pressure roller will be compressed at point of contact with capstan by approximately  $1/32$ ". This measurement may be observed by lightly touching the roller to the capstan, then observing the further travel of the roller shaft as the solenoid is pushed to the bottom of the stroke.

If compression of pressure roller is too great, and excessive pinching occurs, loosen locknut N (Fig. 7-4) on solenoid plunger rod and turn plunger clockwise to reveal more threads on rod. Recheck pressure roller as above and tighten locknut N.

If pressure on roller is too low, the solenoid plunger should be turned counterclockwise in order to bring the linkage arms closer to a straight line position when plunger is at bottom of stroke. Be sure to tighten locknut N.

Important: The two long arms of the linkage assembly must be in a near straight line position when solenoid stroke is down. See (Fig. 7-4). In no case must linkage arms fall below a straight line position or plunger will not return to its open position. If the pivot point at the center of the two long arms is more than  $1/8$ " above the inline position of the arms, readjustment of the anchor pivot A (Fig. 7-4) is required. Loosen pivot screw A and

## 2.3 MAINTENANCE (cont'd)

move the bearing up to increase the pressure roller compression and down to reduce it. Only a very small movement is required. The correct position will permit proper pressure roller compression when the solenoid is at the bottom of its stroke and the long linkage arms are in a straight line position or not more than 1/8" above at the center point. Be sure to tighten all adjustments. Try linkage by hand to see that it is working freely.

RETURN SPRING ADJUSTMENT -- Determine that the spiral return spring is fastened firmly by screw in deck near flywheel. The free end of the spring must ride between washer and head of pivot on the drag link.

SOLENOID ADJUSTMENT -- Solenoid must be firmly fastened to its mounting frame, and must be located to satisfy the following conditions:

1. When lever arms have been adjusted as described above, solenoid position must permit arms to come to an in-line position at the bottom of plunger stroke.
2. The axis of the plunger must be at, or near, a right angle to the lever arms in their bottom-of-stroke location. If these two conditions are not satisfied, loosen solenoid bolts and shift position. Tighten securely.

BACK BUMPER SPRING ADJUSTMENT -- Bumper spring T (see Fig. 7-5) is adjusted by screw C (Fig. 7-5) to limit return position of pressure roller. Adjust the bumper spring so that the pressure roller is just even with the deck plate when solenoid is released from its bottom position. If bumper is too far back linkage may return beyond center position where it cannot be pulled back by the solenoid.

HEAD ALIGNMENT -- The alignment of heads is standard procedure. An accurately recorded test tape with 5,000 cps on both tracks is available on order. Use a thin wrench on the square boss between the head and the mounting bracket and turn slightly while reading the output on a suitable meter. Adjust for maximum output. The cue head may be aligned by moving the program amplifier cable from its head to the cue head socket and repeating the above procedure. Do not attempt to turn heads by twisting the cases.

## 2.3 MAINTENANCE (cont'd)

PROGRAM AND TONE-CUE HEADS -- may accumulate dust, dirt and oxide. They should be inspected periodically and cleaned when necessary with a cloth dipped in carbon tetrachloride. A dirty head will result in distortion, low volume or complete failure of the cue system.

The pressure roller may be cleaned with alcohol. This may be accomplished by removing the cover plate from the top of the playback deck. After removal, hold the micro-switch in the "on" position and press the start button. This will bring the pressure roller in position for cleaning.

CUE SENSITIVITY -- The cue tone amplifier sensitivity control is R108 (Fig. 7-2). This control is adjusted at the factory for optimum performance. If spurious power line clicks should trigger the circuit and falsely stop the tape, turn the control *counter* clockwise to reduce sensitivity.

GAIN CONTROL -- The program amplifier gain control located on each playback unit R208 (Fig. 7-5) is used to balance the audio output of each playback when used with other playback units. Audio output can thereby be balanced between all playback units. Use as little gain as necessary. ~~Controls are set at factory approximately 1/3 to 1/2 full rotation and their adjustment normally will be in this region.~~

RELAYS -- Remove relay covers to clean and burnish relay contacts periodically.

OSCILLATOR BALANCE -- The bias oscillator may be balanced by adjusting the balance control for equal voltage between the center arm and the end terminals. A vacuum tube voltmeter should be used.

HUM BALANCE -- This control R107 (Fig. 7-3) is adjusted for minimum hum.

## 2.4 SPECIFIC CORRECTION ADJUSTMENTS

Automatic Tape Control equipment contains electronic circuitry that is unique to this method of tape recording.



## 2.4 SPECIFIC CORRECTION ADJUSTMENTS (cont'd)

Maintenance of this type of equipment is comparatively new to the broadcast industry and in many cases may not have been previously experienced. To facilitate the correction of certain problems that may be experienced in field use, the following recommendations for specific adjustments are provided.

## DOES NOT CUE:

- a. Determine if a cue signal has actually been recorded on the tape. This may be done by removing the cue plug from its head and substituting the program head plug. The cue-tone will then be reproduced through the program circuits.
- b. Check the cue head alignment, using the head alignment tape, in both the vertical and horizontal planes. Be sure head is clean of foreign matter.
- c. See that pressure pads are in place as described in Section 5. Pressure pads are especially important where cartridges with short lengths of tape are used.
- d. Check tubes in the cue-tone amplifier. These tubes should be checked periodically since there will be no prior indication of their deterioration.
- e. Check the connecting cord between the cue head and the cue amplifier.
- f. Check bias tap on R102. The negative voltage measured from the lower end of this resistor to the moveable tap should be 60 volts.
- g. Clean all relay contacts.

## FALSE CUES OR STOPS:

- a. Should the machine stop approximately every four seconds after the "Start" switch is depressed, a continuous cue signal has probably been accidentally recorded. Clean the contacts on CR403.
- b. The most common cause of false stops is switching transients from other equipment. Reduce the cue sensitivity.

## 2.4 SPECIFIC CORRECTION ADJUSTMENTS (cont'd)

- c. Check tubes in cue amplifier.
- d. Should the solenoid drop out as soon as the "Start" button is released, inspect contacts of relays CR101, CR102 and CR103. Relay CR103 is de-energized except when receiving a cue signal. Should this relay be continuously energized, the sensitivity control is set too sensitive and will cause a solenoid drop-out. Decrease sensitivity. Be sure the "Stop" push-button is not sticking.

## UNSATISFACTORY PROGRAM QUALITY:

- a. Check head alignment with the alignment tape.
- b. Clean heads.
- c. Check pressure pads as described in Section 5.
- d. Check tubes in the program amplifier.
- e. Check tubes in the recording amplifier.
- f. Be sure the program amplifier gain control (R208) has not been advanced to a point where the amplifier is being over-driven.

## SECTION 3

## AUTOMATIC SWITCHER

## 3.1 INSTALLATION

The AMS-3 will automatically switch a maximum of three playback units to one input. The AMS-4 will switch a maximum of four machines.

If connecting an AMS-3, leave connections 7-8 empty on the "Start", "Stop" and "Input" terminal strips.

## CONNECTIONS TO "START" TERMINAL STRIP --

Connect a pair of wires from the "Auxiliary Start" terminals of playback machine 1 to "Start" terminals 1-2 of the Automatic Switcher. Connect the "Auxiliary Start" terminals of playback machine 2 to "Start" terminals 3-4 of the switcher. If a third playback machine is used, connect the "Auxiliary Start" terminals to "Start" terminals 5-6 of the switcher. If a fourth machine and an AMS-4 switcher is used, the "Auxiliary Start" terminals of machine 4 are connected to "Start" terminals 7-8 of the switcher.

## CONNECTIONS TO THE "STOP" TERMINAL STRIP --

Connect a pair of wires from the "Cue Stop" terminals of playback machine 1 to terminals 1-2 of the "Stop" terminal strip of the Automatic Switcher. Connect from the "Cue Stop" terminals of playback 2 to terminals 3-4 of the "Stop" strip. Continue this wiring using terminals 5-6 for playback 3 and terminals 7-8 if a fourth machine and an AMS-4 are in use.

## CONNECTIONS TO THE "IN AND OUT" TERMINAL STRIP--

Connections to this strip are all audio circuits. Connect the 600 ohm output of playback 1 to terminals 1-2 of this strip. Connect the 600 ohm output of playback 2 to terminals 3-4 of this strip. Continue this wiring using terminals 5-6 for playback 3 and terminals 7-8 if a fourth machine and an AMS-4 are used. Terminals 9-10 of this strip are the audio output of the switcher and should be connected to the input of the console. All audio wiring should be shielded pair, preferably with an insulated outer jacket.

### 3.2 OPERATION

When any playback is started the proper switcher relay is pulsed and locked in to feed the audio to the console. When a second playback is started, the first relay is released and the second relay is locked in the circuit. This same process occurs for any number of playbacks.

The only function of the "Stop" connections is to release the last relay after the last tape has cued. Obviously this feature could be omitted if desired. Should this be done it would be necessary to short the pairs of the "Stop" strip for the channels used. These units are shipped with these shorts in place. They should be removed if the "Stop" or disconnect feature is used. This automatic disconnect feature will perform the function of disconnecting, from the mixer, any unit which is not actually in use. Connections to the "Stop" and "Start" terminals are DC control functions.

### 3.3 MAINTENANCE

Remove cover plate over relay contacts, and clean and burnish relay contacts periodically. See (Fig. 7-11).



## SECTION 4

## REMOTE CONTROL PANELS

## 4.1 INSTALLATION

RC-P REMOTE CONTROL PANEL -- A pair of wires is connected from playback 1 "Remote Start" terminals to terminals 1-2 of the remote control panel. The "Remote Start" terminals of machine 2 are connected to remote control panel terminals 3-4. The "Remote Start" terminals of machine 3 are connected to remote control panel terminals 5-6. The terminals of the remote control panel are numbered from left to right facing the terminal strip.

RC-R REMOTE CONTROL PANEL -- A pair of wires is connected from the "Remote Start" terminals of the playback unit connected to the recording amplifier to terminals 1-2 of the remote control panel. The "Remote Set" terminals, located on the back of the recording amplifier, are connected to terminals 3-4 of the remote panel terminal strip. The "Remote Stop" terminals of the playback unit connected to the recording amplifier are connected to terminals 5-6 of the remote control panel. The connections of the remote control panel are numbered from left to right facing the terminal strip.

RC-RP REMOTE CONTROL PANEL -- This panel is a combination of the RC-P and RC-R panels described above. Connections are identical using the upper terminal strip for connections to the recording unit, as with the RC-R, and the lower terminal strip for the playback units as for the RC-P.

## 4.2 OPERATION

RC-P REMOTE CONTROL PANEL -- is used where it is desired to control a maximum of three playback units from a remote position.

RC-R REMOTE CONTROL PANEL -- is used where it is desired to control a Record/Playback machine from a remote point.

#### 4.2 OPERATION (cont'd)

RC-RP REMOTE CONTROL PANEL -- is used where it is desired to control one Record/Playback unit and a maximum of three playback units from a remote point. This same panel may also be used to control four playback units through an AMS-4 switcher.

#### 4.3 MAINTENANCE

None required.

## SECTION 5

### CARTRIDGES

#### 5.1 OPERATION

The cartridge consists of an endless loop of lubricated tape on a free turning hub. The tape loops out from the center, travels around the left guide post, across the heads and around the right guide to be wound back on the outside of supply hub.

#### 5.2 LOADING

##### OPEN CARTRIDGE (See Figure 5-1)

1. The center screw is removed from the cover.
2. The cover is taken off.
3. The wire guide is removed.
4. The reel can then be lifted out.
5. Roll on reel the desired amount of tape with oxide out.  
(See Figure 5-2)
6. Remove about 5 inches of tape from the center of the reel and about 5 inches from the outside of the reel.  
(See Figure 5-3)
7. Splice in normal manner on the side of tape away from the heads with mylar base splicing tape if available.

##### CLOSE CARTRIDGE

1. Place reel in cartridge with the cartridge head openings facing you.
2. With one hand release the spring brake and pull tape from the center until slack is taken up. (See Figure 5-4)
3. Place tape around guide post through front guide slots and left guide.
4. Place wire guide under tape coming from center hub, place ends of wire in their respective slots.
5. Put cover in place being sure wire guide is in place and that lid is not pinching tape.
6. Insert center screw.

## 5.2 LOADING (cont'd)

7. Place in playback unit and run through several times. In some cases there is a slight jerking of tape as it comes off center hub until center slack has worked to the outside where it will disappear.
8. If the cartridge is placed in use without preliminary running there may be a slight tendency for the tape to drag and wow.

## 5.3 MAINTENANCE

## PRESSURE PADS

1. Ends of pressure pads must be bent till they are 1/8 inch from the edge of cartridge. (See Figure 5-5)
2. Pressure pads must be in cartridge in a horizontal plane. (See Figure 5-5)
3. Felt must not be wider than pressure spring by more than 1/32 inch above or below. (See Figure 5-5)
4. Re-glue any loose felts with any good grade glue or household cement.

## LENGTH OF LOOP

1. If tape becomes too loose in cartridge, it will be apparent in one of two ways. (See Figure 5-6)
  - a. Tape loops out of revolving capstan slot.
  - b. Tape loose on hub.
2. Remove the center screw and lift cover.
3. With one hand release the spring brake and pull tape from center until splice is in the loop.
4. Cut the tape on the old splice and take out 2 to 4 inches of tape depending upon how loose the tape has become.
5. Close cartridge. (As described above)
6. Place cartridge in playback unit and run through several times before placing back in use.
7. If the tape is too tight, the tape will have a tendency to wow. The same procedure is followed as when the tape was too loose, but instead of removing tape from the loop, unwind one turn from the outside of reel, increase amount of tape in loop and re-splice.



5.4 ILLUSTRATIONS OF CARTRIDGES

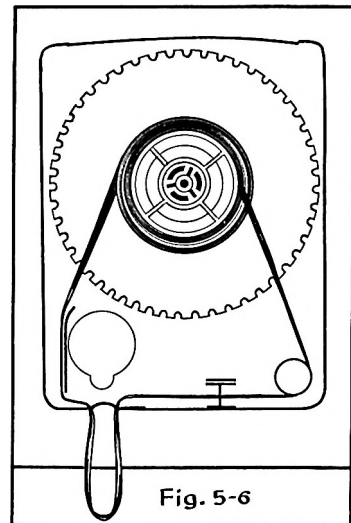
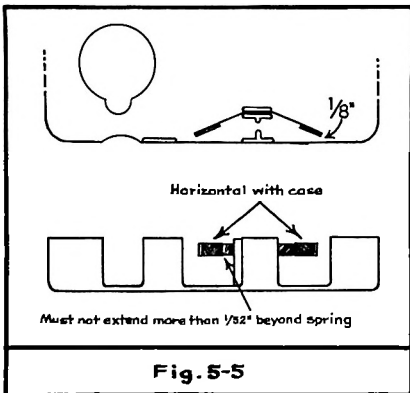
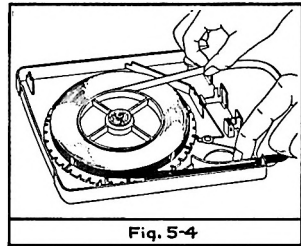
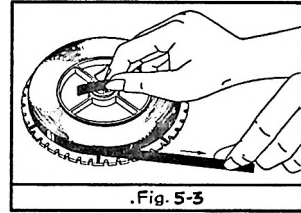
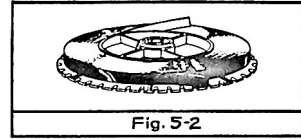
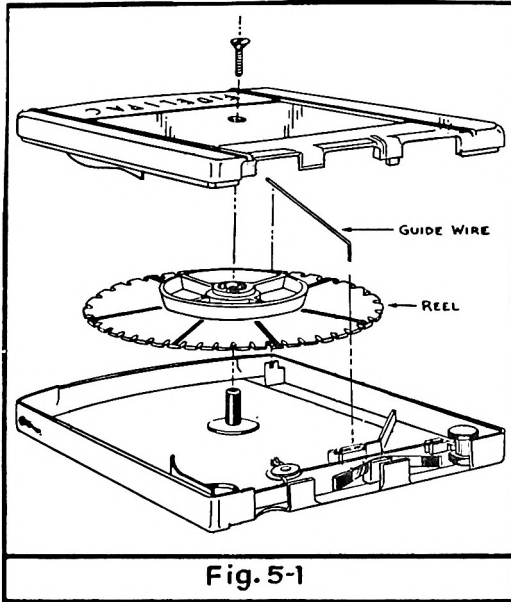

## SECTION 6

## PARTS LIST

## 6.1 PLAYBACK UNIT P190 and P150

<u>ITEM NO.</u>	<u>DESCRIPTION</u>
C101	CAPACITOR, 20/20/20/20-450 volts
C102	CAPACITOR, 20 mfd 150 volt electrolytic
C103	CAPACITOR, 16 mfd 450 volt electrolytic
C104	CAPACITOR, 20 mfd 150 volt electrolytic
C105	CAPACITOR, .15 mfd 400 volts
C106	CAPACITOR, 1000 mfd 15 volts electrolytic
C107	CAPACITOR, 1000 mfd 15 volts electrolytic
C108	CAPACITOR, 20 mfd 150 volts electrolytic
C109	CAPACITOR, .1 mfd 600 volts
CC102	CORD, head connecting
CR101	RELAY, control, 12 volt, KRP14D, 3PDT
CR102	RELAY, control, 12 volt, KRP11D, DPDT
CR103	RELAY, control, 2500 ohm, KCP11D, DPDT
F101	FUSE, 3 ampere, 3AG
H101	HEAD, magnetic, cue
H102	HEAD, magnetic, program
J101	JACK, cue input
J102	JACK, program input
P101	PLUG, equipped with R109 and R110
PL101	PILOT LIGHT, green, bulb GE 1813 12 volt
PL102	PILOT LIGHT, amber, bulb GE 1813 12 volt
R101	RESISTOR, 2250 ohms 10 watts
R102	RESISTOR, 15,000 ohms 25 watts, adjustable
R103	RESISTOR, <del>100,000 ohms</del> 1/2 watt
R104	RESISTOR, 100,000 ohms 1/2 watt
R105	RESISTOR, 270,000 ohms 1/2 watt
R106	RESISTOR, 47,000 ohms 1/2 watt
R107	RESISTOR, 400 ohms variable, hum balance
R108	RESISTOR, 5000 ohms, wire wound, variable
R109	RESISTOR, 30,000 ohms, 10 watts
R110	RESISTOR, 2700 ohms, 1 watt
S101	SOCKET, 11 pin, cue amplifier socket
S102	SOCKET, 8 pin, program amplifier socket
S103	SOCKET, record amplifier power

## 6.1 PLAYBACK UNIT P190 and P150 (cont'd)

<u>ITEM NO.</u>	<u>DESCRIPTION</u>
SIL101	RECTIFIER, silicon A750 (1N1449)
SIL102	RECTIFIER, silicon 10A1 (1N1446)
SIL103	RECTIFIER, silicon 10A1 (1N1446)
SOL	SOLENOID, MS-3
SW101	SWITCH, toggle, AH&H 20994LH
SW102	SWITCH, momentary make, AH&H 3392A
SW103	SWITCH, momentary break, AH&H 3392AR
SW104	SWITCH, micro, licon 10-622
T101	TRANSFORMER, power, RK1474
T102	TRANSFORMER, audio output, UTC-08
V101	TUBE, 5Y3, rectifier

## 6.2 PROGRAM AMPLIFIER

<u>ITEM NO.</u>	<u>DESCRIPTION</u>
C201	CAPACITOR, .01 mfd disc
C202	CAPACITOR, .001 mfd
C203	CAPACITOR, .05 mfd
C204	CAPACITOR, .05 mfd
C205	CAPACITOR, .5 mfd 400 volts
R201	RESISTOR, 1 megohm 1/2 watt
R202	RESISTOR, 680 ohms 1/2 watt
R203	RESISTOR, 470,000 ohms 1/2 watt
R204	RESISTOR, 47,000 ohms 1/2 watt
R205	RESISTOR, 1 megohm 1/2 watt
R206	RESISTOR, 3300 ohms 1/2 watt
R207	RESISTOR, 220,000 ohms 1/2 watt
R208	RESISTOR, 500,000 ohm gain control
R209	RESISTOR, 2200 ohms 1/2 watt
R210	RESISTOR, 100,000 ohms 1/2 watt
R211	RESISTOR, 62,000 ohms 1/2 watt
R212	RESISTOR, 470,000 ohms 1/2 watt
R213	RESISTOR, 1200 ohms 1/2 watt
R214	RESISTOR, 47,000 ohms 1/2 watt
V201	TUBE, 12AX7/ECC83
V202	TUBE, 12AX7/ECC83

## 6.3 CUE CONTROL AMPLIFIER/OSCILLATOR

<u>ITEM NO.</u>	<u>DESCRIPTION</u>
C301	CAPACITOR, 270 mmfd disc
C302	CAPACITOR, 270 mmfd disc
C303	CAPACITOR, 750 mmfd disc
C304	CAPACITOR, .05 mfd disc
C305	CAPACITOR, 6 mfd 12 volt electrolytic
C306	CAPACITOR, .05 mfd
C307	CAPACITOR, 6 mfd 12 volt electrolytic
D301	RECTIFIER, silicon 1N462
R301	RESISTOR, 100,000 ohms 1/2 watt
R302	RESISTOR, 220,000 ohms 1/2 watt
R303	RESISTOR, 220,000 ohms 1/2 watt
R304	RESISTOR, 2200 ohms 1/2 watt
R305	RESISTOR, 1 megohm 1/2 watt
R306	RESISTOR, 2200 ohms 1/2 watt
R307	RESISTOR, 1 megohm 1/2 watt
R308	RESISTOR, 2200 ohms 1/2 watt
R309	RESISTOR, 1 megohm 1/2 watt
R310	RESISTOR, 1 megohm 1/2 watt
V301	TUBE, 12AX7/ECC83
V302	TUBE, 12AU7/ECC82

## 6.4 RECORDING AMPLIFIER A190 and A150

<u>ITEM NO.</u>	<u>DESCRIPTION</u>
C401	CAPACITOR, 25 mfd 25 volt
C402	CAPACITOR, .1 mfd disc
C403	CAPACITOR, 25 mmfd disc
C404	CAPACITOR, .05 mfd
C405	CAPACITOR, .01 mfd, disc
C406	CAPACITOR, 470 mmfd, disc
C407	CAPACITOR, 25 mfd 25 volt
C408	CAPACITOR, 50 mmfd, disc
C409	CAPACITOR, 750 mmfd, disc
C410	CAPACITOR, 270 mmfd, disc
C411	CAPACITOR, .001 mfd, disc
C412	CAPACITOR, 450 mmfd, disc
C413	CAPACITOR, 450 mmfd, disc
C414	CAPACITOR, .1 mfd, disc
C415	CAPACITOR, .5 mfd, 400 volt
C416	CAPACITOR, 16 mfd, 450 volt, electrolytic
C417	CAPACITOR, .1 mfd, 400 volt

## 6.4 RECORDING AMPLIFIER A190 and A150 (cont'd)

<u>ITEM NO.</u>	<u>DESCRIPTION</u>
CC402	CORD, head connecting
CC403	CORD, record amplifier connecting
CR401	RELAY, head transfer, MG11D, DPDT
CR402	RELAY, tone keyer, 2500 ohm, KCP11D, DPDT
CR403	RELAY, record set, KRP14D, 3PDT
D401	RECTIFIER, meter, 1N34A
M401	METER, volume indicator, A361
PL401	PILOT LIGHT, GE 1813
R401	RESISTOR, 220 ohm 1/2 watt
R402	RESISTOR, 56 ohm 1/2 watt
R403	RESISTOR, 220 ohm 1/2 watt
R404	RESISTOR, 2200 ohm 1/2 watt
R405	RESISTOR, 100,000 ohm 1/2 watt
R406	RESISTOR, 2.2 megohm 1/2 watt
R407	RESISTOR, 100,000 ohm 1/2 watt
R408	RESISTOR, 220,000 ohm 1/2 watt
R409	RESISTOR, 2200 ohm 1/2 watt
R410	RESISTOR, 100,000 ohm 1/2 watt
R411	RESISTOR, 500,000 ohm, variable, gain control
R412	RESISTOR, 47,000 ohm 1/2 watt
R413	RESISTOR, 220,000 ohm 1/2 watt
R414	RESISTOR, 250,000 ohm, variable, meter calibrate
R415	RESISTOR, 2200 ohm 1/2 watt
R416	RESISTOR, 8200 ohm 2 watt
R417	RESISTOR, 1000 ohm 1/2 watt
R418	RESISTOR, 22,000 ohm 1/2 watt
R419	RESISTOR, 22,000 ohm 1/2watt
R420	RESISTOR, 1800 ohm 1/2 watt
R421	RESISTOR, 100,000 ohm 1/2 watt
R422	RESISTOR, 2700 ohm 1 watt
R423	RESISTOR, 2200 ohm 1/2 watt
R424	RESISTOR, 30,000 ohm 10 watt
R425	RESISTOR, 5600 ohm 1/2 watt
R426	RESISTOR, 100,000 ohm, variable, oscillator balance
SW401	SWITCH, momentary make, AH&H 3392AP, record set
T401	TRANSFORMER, audio input, UTC 0-1
T402	TRANSFORMER, bias oscillator, D501
V401	TUBE, 12AU7/ECC82, amplifier
V402	TUBE, 12AU7/ECC82, meter amplifier
V403	TUBE, 12AU7/ECC82, bias oscillator

## 6.5 AUTOMATIC SWITCHER AMS3 and AMS4

<u>ITEM NO.</u>	<u>DESCRIPTION</u>
C501	CAPACITOR, 500 mmfd 15 volt electrolytic
C502	CAPACITOR, .01 mfd disc
C503	CAPACITOR, .01 mfd disc
C504	CAPACITOR, .01 mfd disc
C505	CAPACITOR, .01 mfd disc
CR501	RELAY, control, MD17D, 12 volt 4PDT
CR502	RELAY, control, MD17D, 12 volt 4PDT
CR503	RELAY, control, MD17D, 12 volt 4PDT
CR504	RELAY, control, MD17D, 12 volt 4PDT
SIL501	RECTIFIER, silicon, 10A1 (1N1446)
T501	TRANSFORMER, power, RK1478

NOTE: AMS3 switchers do not use CR504 and C505

SECTION 7

ILLUSTRATIONS

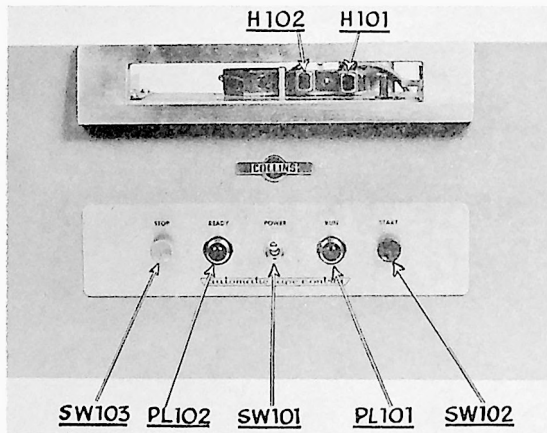

Fig. 7-1 Playback Parts Arrangement - Front View

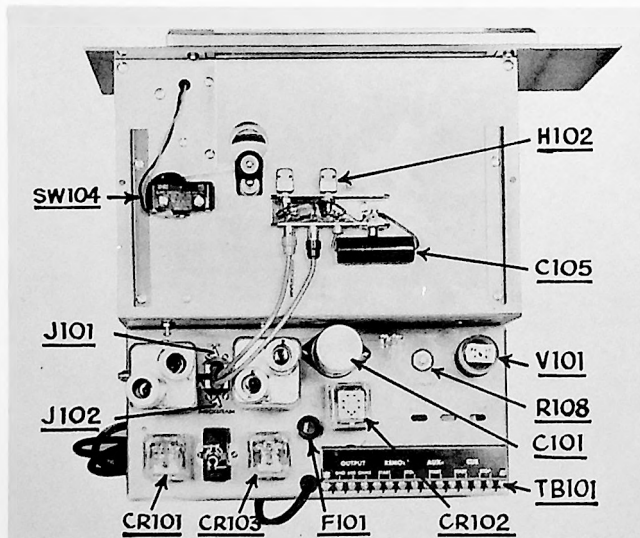

Fig. 7-2  
Playback Parts  
Arrangement -  
Top View

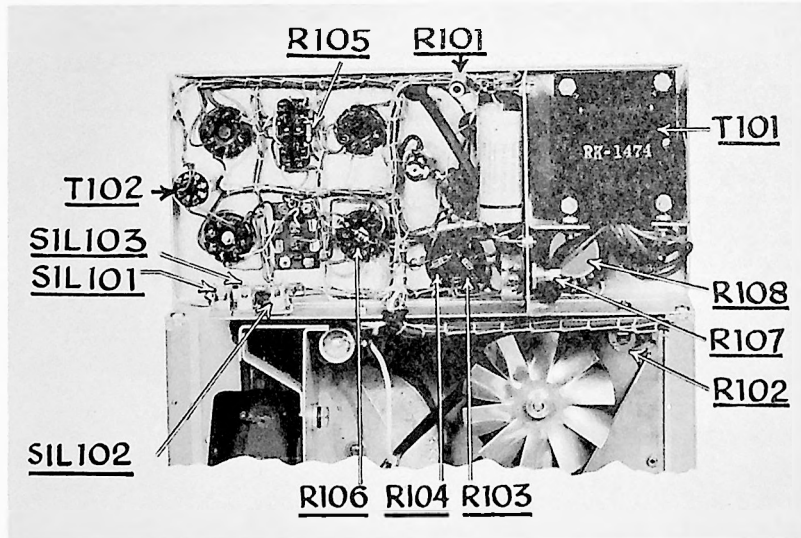

Figure 7-3  
Playback Parts Arrangement  
Bottom View



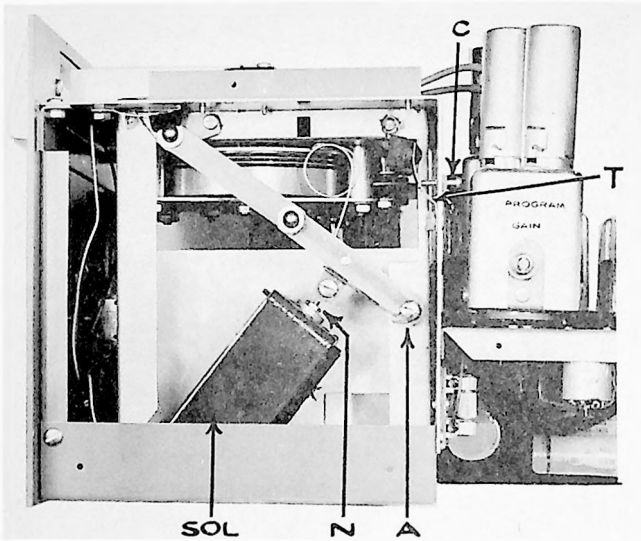

Fig. 7-4  
Playback Parts  
Arrangement -  
Side View

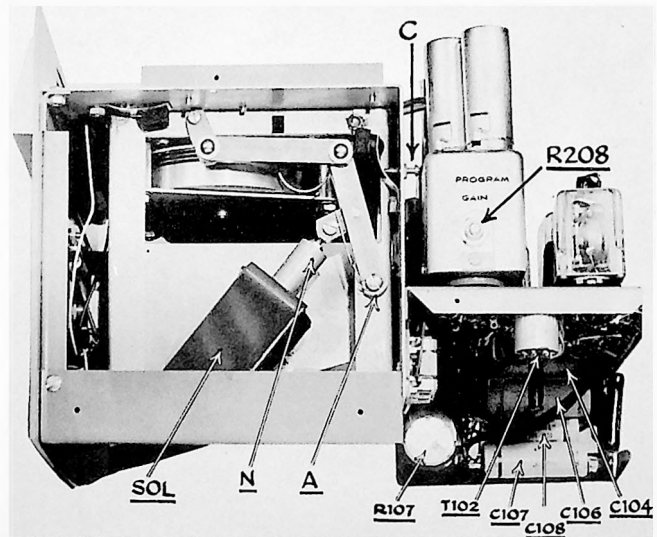

Fig. 7-5  
Playback Parts  
Arrangement -  
Side View

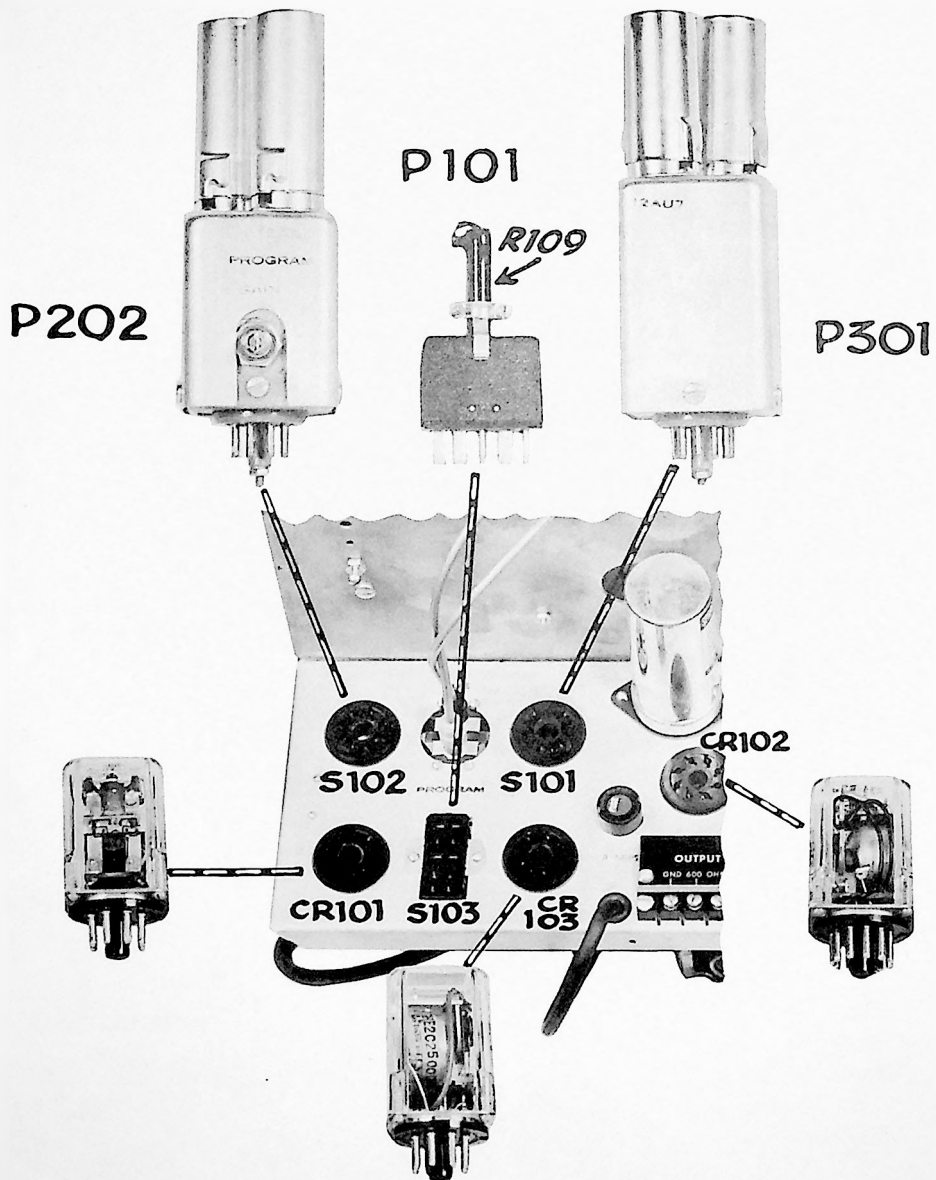

Fig. 7-6  
Plug-in Components

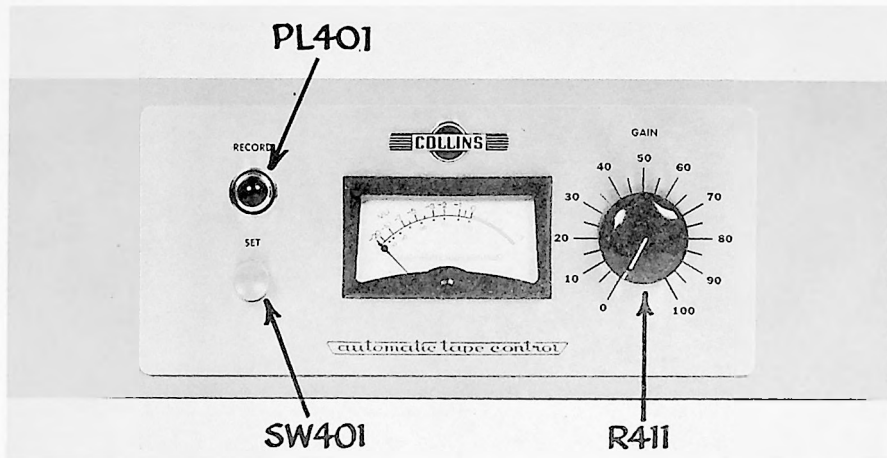

Fig. 7-7 - Amplifier Parts Arrangement  
Front View

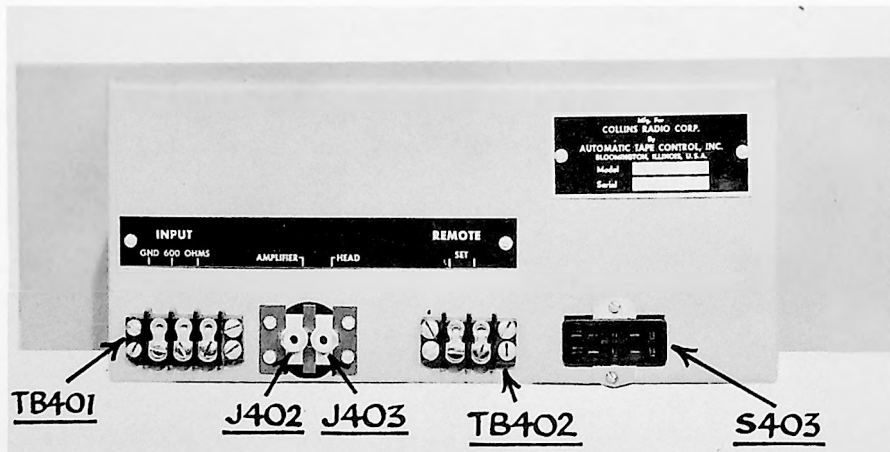

Fig. 7-8 - Amplifier Parts Arrangement  
Rear View

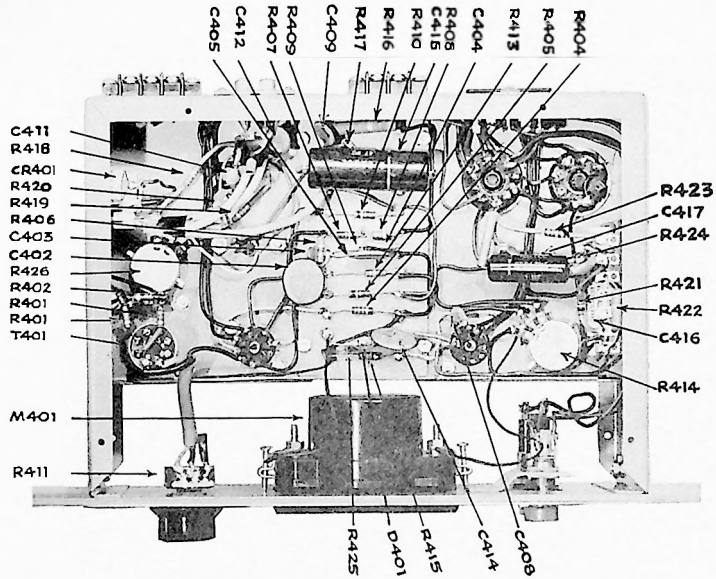

Fig. 7-9 - Amplifier Parts Arrangement  
Bottom View

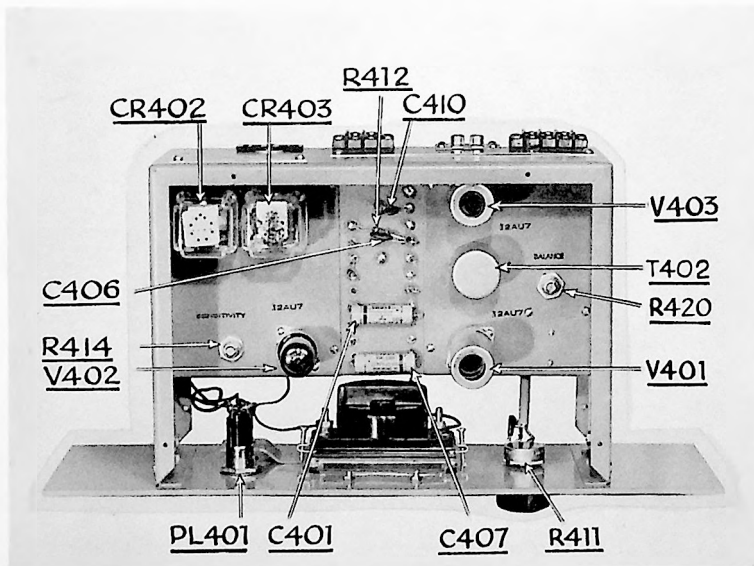

Fig. 7-10 - Amplifier Parts Arrangement  
Top View

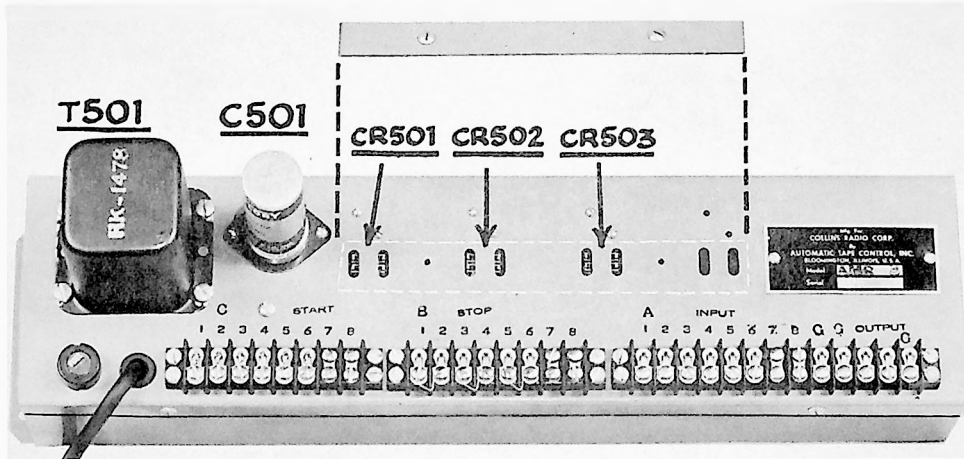
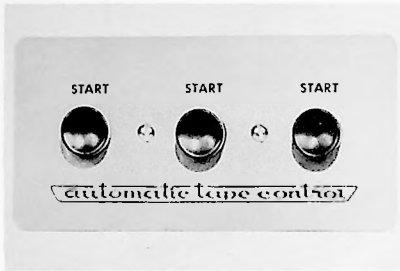
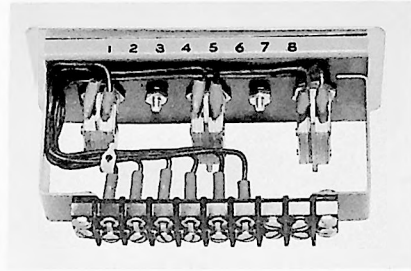

Fig. 7-11 - Switcher Parts Arrangement  
Top View



Front View



Back View

Fig. 7-12 - RC-P Remote Control Panel



Front View

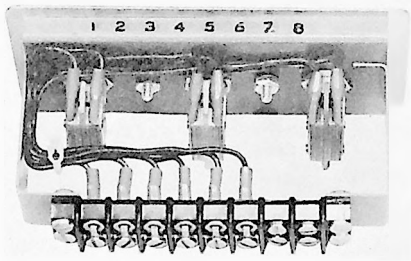

Back View

Fig. 7-13 - RC-R Remote Control Panel



Front View

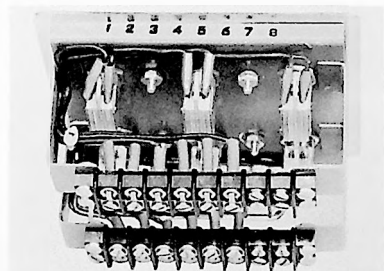

Back View

Fig. 7-14 - RC-PR Remote Control Panel

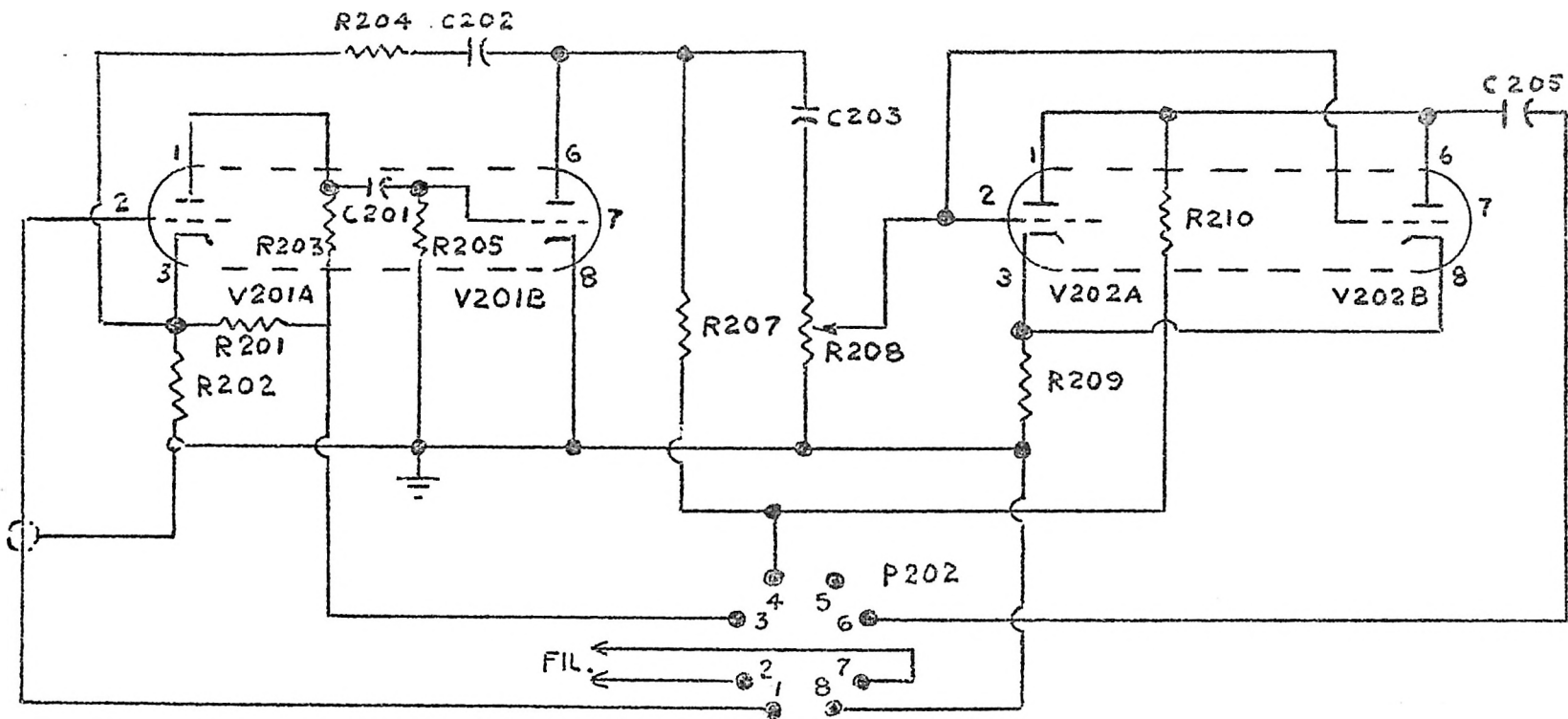

R201 - 220K ohm  
 R202 - 1000 ohm  
 R203 - 330K ohm  
 R204 - 100K ohm  
 R205 - 2.2 megohm  
 R207 - 100K ohm  
 R208 - 500K ohm  
 R209 - 680 ohm  
 R210 - 47K ohm

C201 - .01 mfd  
 C202 - 750 mmfd  
 C203 - .01 mfd  
 C205 - .25 mfd  
 V201 - 12AX7  
 V202 - 12AU7

REVISED PROGRAM SECTION  
 7/10/59







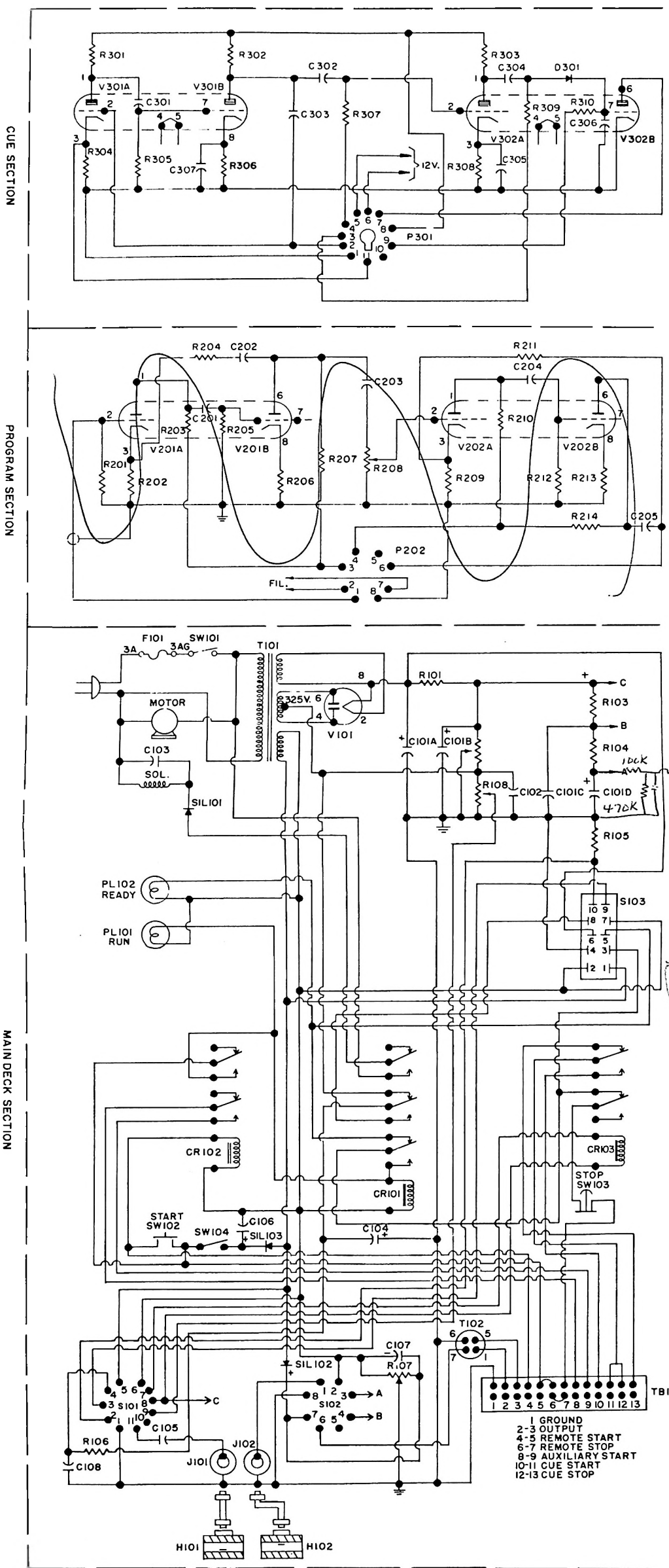
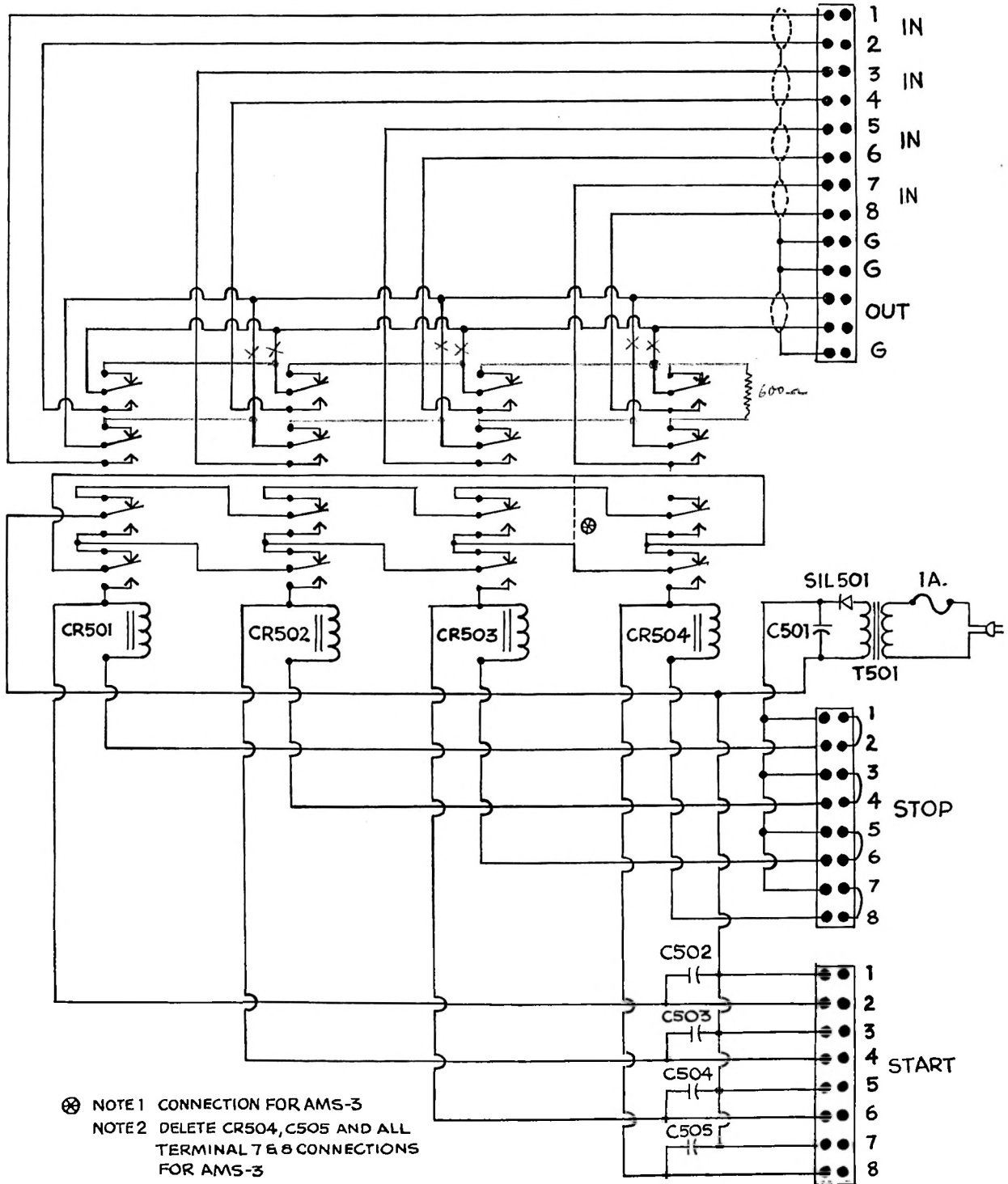

FIGURE 8-2  
AUTOMATIC TAPE CONTROL PLAYBACK SCHEMATIC

*Dummy Plug*



- ⊗ NOTE 1 CONNECTION FOR AMS-3
- NOTE 2 DELETE CR504, C505 AND ALL TERMINAL 7 & 8 CONNECTIONS FOR AMS-3

FIGURE 8-3  
AUTOMATIC SWITCHER

**NOT APPLICABLE TO  
AUTOMATIC TAPE CONTROL UNITS**

## HOOK-UP WIRE CODE

The characteristics of the hook-up wire used in this equipment are indicated by groups of symbols on the diagrams. Each symbol group consists of a maximum of three letters followed by a maximum of three numerals. When three letters are used the first indicates the type of wire, the second represents the size of wire, and the third is the letter "S", used only when the wire is shielded. When two letters are used, the first and second letters indicate either the type and size of wire or the size of wire and shielding, respectively. When one letter is used it indicates the wire size only. The first numeral indicates the color of the wire body and the second and third numerals, if any, represent the colors of tracers, all numerals being in accordance with the standard EIA and MIL-W-16878 color code.

The symbols are assigned according to the following table.

TYPE OF WIRE CODE		SIZE OF WIRE CODE		COLOR CODE	
LETTER	TYPE OF WIRE	LETTER	SIZE	NUMBER OR LETTER	COLOR
A	Cotton Braid Over Plastic (Formerly AN-J-C-48)	A	#22 AWG	0	Black
B	Busbar, Round Tinned	B	#20	1	Brown
C	MIL-W-16878 Type B (#20 and Larger) (600 Volts)	C	#18	2	Red
D	Miniature Wire, MIL-W-16878 Type B (#22 and Smaller)	D	#16	3	Orange
E		E	#14	4	Yellow
F	Extra Flexible Varnished Cambric	F	#12	5	Green
G		G	#10	6	Blue
H	Kel-F (Monochlorotrifluoroethylene)	H	#8	7	Violet
J		J	#6	8	Gray (Slate)
K	Neon Sign Cable (15,000 Volts)	K	#4	9	White
L	Silicone	L	#2	a	Clear
M		M	#1	b	Tan
N	Single Conductor Stranded (Not Rubber Covered)	N	#0	c	Pink
P	Single Conductor Stranded (Rubber Covered)	P	#00	d	Maroon
Q		Q	#000	e	Light Green
R	MIL-W-16878 Type C (1000 Volts)	R	#0000	f	Light Blue
T	Teflon, MIL-W-16878 Type E (600 Volts)	T	#28		
V	MIL-W-16878 Type D (3000 Volts)	V	#26		
W	Teflon, MIL-W-16878 Type EE (1000 Volts)	W	#24		
X		X	#19		
Y		Y	#30		
Z	Acetate Yarn, Telephone Type	Z			

### EXAMPLES

MIL TYPE C, #22AWG, UNSHIELDED WIRE, WHITE WITH RED AND GREEN TRACERS:

R	A	9	25	4-1/4	
Type of Wire	Size of Wire	Color of Body	Color of Tracers	Length of Wire in Inches	-- (Includes Stripping & Tinning)

MIL TYPE C, #16AWG, SHIELDED WIRE (SINGLE), WHITE WITH RED AND GREEN TRACERS:

R	D	S	9	25	4-1/4	
Type of Wire	Size of Wire	Shielded	Color of Body	Color of Tracers	Length of Wire in Inches	-- (Includes Stripping & Tinning)

MIL TYPE B, #22AWG, SHIELDED WIRE (MULTIPLE), WHITE, AND WHITE WITH RED TRACER:

D	A	S	(9)	(92)	4-1/4	
Type of Wire	Size of Wire	Shielded	First Conductor	Second Conductor	Length of Wire in Inches	-- (Includes Stripping & Tinning)



---

**COLLINS RADIO COMPANY**