

**training manual**

*Product Support Division/Collins Radio Company, Cedar Rapids, Iowa*

**Fundamentals of  
Semiconductors**

523-0756493-00281G  
15 September 1963  
2nd Edition, 15 June 1964

---



**training manual**

---

**Fundamentals of  
Semiconductors**

---

©Collins Radio Company 1963, 1964

*Product Support Division/Collins Radio Company, Cedar Rapids, Iowa*

Printed in U.S.A.

# table of contents

Chapter		Page
	Foreword . . . . .	iii
1	DIODES . . . . .	1-1
	Introduction . . . . .	1-1
	Diode Biasing . . . . .	1-5
	Review . . . . .	1-14
	Section 1 Work Problems . . . . .	1-21
2	TRANSISTOR BIASING AND CONFIGURATIONS . . . . .	2-1
	Introduction . . . . .	2-1
	Transistor Biasing . . . . .	2-1
	Transistor Currents . . . . .	2-4
	Transistor Circuit Characteristics . . . . .	2-6
	Common Base Configurations . . . . .	2-8
	Review . . . . .	2-9
	Section 2 Work Problems . . . . .	2-13
	Introduction . . . . .	2-15
	Common Emitter Configuration . . . . .	2-15
	Common Collector Configuration . . . . .	2-19
	Review . . . . .	2-26
	Section 3 Work Problems . . . . .	2-31
3	BIAS STABILIZATION . . . . .	3-1
	Introduction . . . . .	3-1
	D-C Computations . . . . .	3-1
	Temperature Stabilization of the Base-Emitter Junction with Resistors . . . . .	3-4
	Temperature Stabilization of the Base-Emitter Junction with Thermistors . . . . .	3-11
	Temperature Stabilization of the Base-Emitter Junction with Diodes . . . . .	3-13
	Review . . . . .	3-14
	Section 4 Work Problems . . . . .	3-19
	Introduction . . . . .	3-21
	Review of the Effects of ICBO . . . . .	3-21
	Temperature Stabilization of the Base-Collector Junction with Resistors . . . . .	3-22
	Temperature Stabilization of the Base-Collector Junction with Diodes . . . . .	3-24
	Duodiode Stabilization . . . . .	3-26
	Voltage Feedback Stabilization . . . . .	3-27
	Methods of Biasing . . . . .	3-29
	Stability Equations . . . . .	3-31
	Transistor Manual Interpretation . . . . .	3-33
	Review . . . . .	3-36
	Section 5 Work Problems . . . . .	3-39
	APPENDIX A SUPPLEMENTARY DATA . . . . .	A-1
	Answers to Work Problems . . . . .	A-1
	Definitions . . . . .	A-10
	Equations . . . . .	A-12
	Servicing Transistor Circuits . . . . .	A-13
	Summary . . . . .	A-16
	Course Critique Form . . . . .	A-17



Prepared by: Collins Radio Company  
Product Support Division Training Department  
Cedar Rapids, Iowa

Knowledge of the theory of music is not essential to music appreciation, but to retune a piano this knowledge is a requirement. The same general statement can be made regarding theory in electronics, especially in the theory of semiconductors.

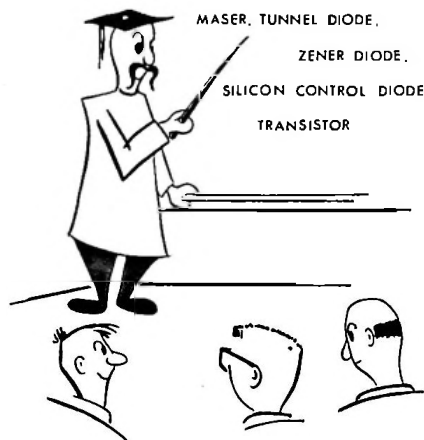

Figure II

Many new terms are being added to the art of electronics. A few of these terms, for example, maser, tunnel diode, zener diode, silicon control rectifier, and transistor (which is a combination of the words transfer-resistor), were not in the vocabulary of the technician even a dozen years ago. Why then so much urgency now?

Transistors are used today in practically every type of equipment, such as computers, servo mechanisms, telemetering instruments, portable radios, physiological (medical) instruments, and portable television sets.

The subject of transistors is so important, and the application is so far reaching, that Collins Radio Company has prepared a series of assignments on semiconductors, and transistors in particular.

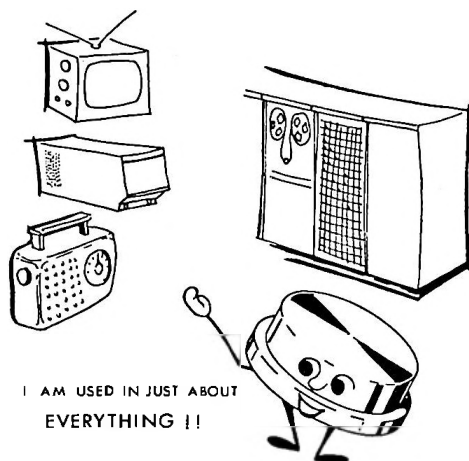

Figure III

Diodes and transistors can be used without understanding how they work, but to be in a position to understand new circuitry for them or to recognize and appreciate new troubles when they occur unexpectedly, one must have a knowledge of basic semiconductor theory. Collins Radio Company includes



Figure IV

a careful study of the fundamentals of semiconductors as a prerequisite for many other courses to place the Collins graduate in a professional position above and ahead of the "do-it-yourself" technician. A technician with the basic knowledge is more likely to recognize, pursue, and capitalize on the unexpected performance of a new circuit; others blindly follow the instruction of a leader.

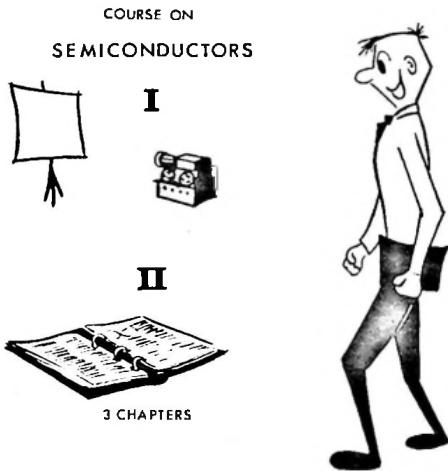

Figure V

This course on semiconductors consists of two basic parts, a tape-slide lecture and a training manual. The material in the training manual matches the tape-slide presentation and is basically divided into three chapters.

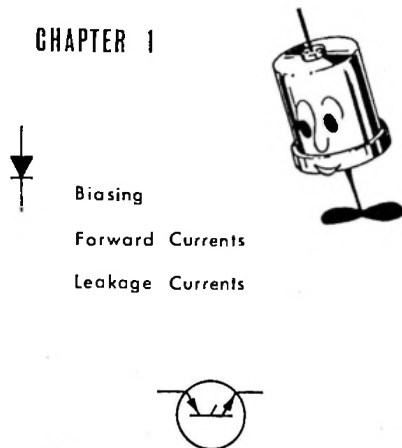

Figure VI

Chapter 1 is an introduction to the course and semiconductors. Additionally, the two-element device, the diode, is discussed in detail. This includes biasing, forward currents, leakage currents, and the curves associated with the Shockley diode and varicaps. Some uses of each of these types of diodes also are shown and explained.

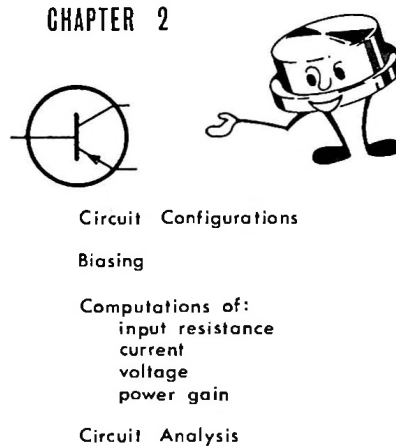

Figure VII

Chapter 2 covers the three-element device, the transistor. The three circuit configurations are discussed in detail. This discussion includes biasing by different methods; computations of input resistance and current, voltage, and power gain; quiescent operating voltages and currents; and a comparison of the three configurations, along with some of the more common terms and equations used in transistor circuit analysis.

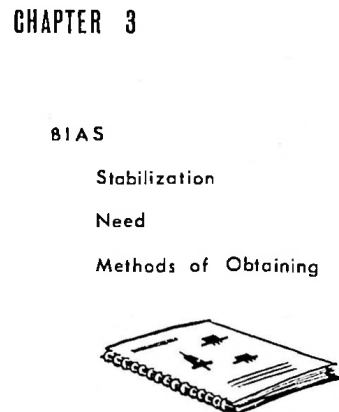

Figure VIII

Chapter 3 presents a discussion on bias stabilization, explains the need for bias stabilization, the various methods used to obtain it, and the basic equations for finding the stability of an unknown circuit. Additionally, a discussion is presented on the interpretation of the transistor specifications as found in a transistor manual.

The course will not be presented in three parts, but rather in five parts. Each part will consist of a one-hour tape-slide presentation and two hours of individual study. During the individual study time, you will be required to read a portion of the manual and work some sample problems. The answers to these problems and a short review of the work will be presented at the beginning of the next tape-slide presentation.

In addition to the problems found in the training manual, an appendix has been added including definitions of terms, mathematical equations, and a course critique.

**5 parts**

each part consists of

**1 hour tape slide**

**2 hours individual study**

Figure IX

### Introduction.

# 1948



Figure 1-1

The transistor is a relatively new device. It made its first appearance about 1948. Since that time, as you well know, it has been widely accepted by industry, and day by day it is making definite gains into the

electronic field. The reason for this can be seen easily by noting figure 1-2.

Figure 1-2 shows the comparative sizes of transistors and tubes and compares the circuit components which are used in transistor circuits with those used in tube circuits.

DON'T ACT SO  
BIG

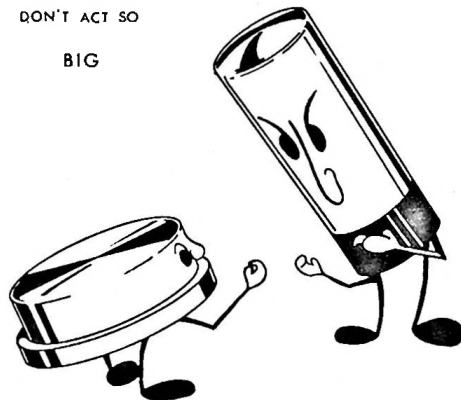

Figure 1-3

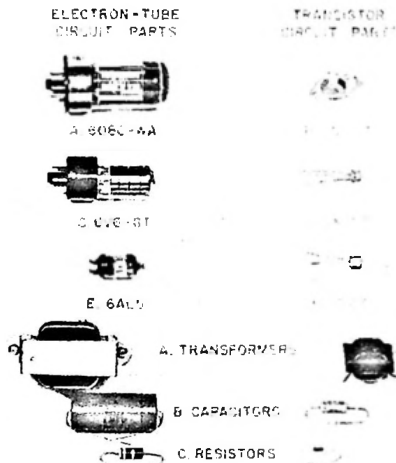

Figure 1-2

In each case, the transistor component is much smaller than the tube circuit component. You may say this is all very fine, but how do transistors compare as far as tubes and operating circuits are concerned?

Compare the transistor to the frequency-handling capability of the tube. The first transistors could not handle frequencies much higher than 5 megacycles. In 1956, the highest known frequency at which any transistor was capable of operating was 8 megacycles. There are now transistors available which will operate to 3 gigacycles. A gigacycle is equal to one kilomegacycle. Although this is not as high in frequency as tubes can be operated, great improvements in transistor frequency response have been made since 1956.



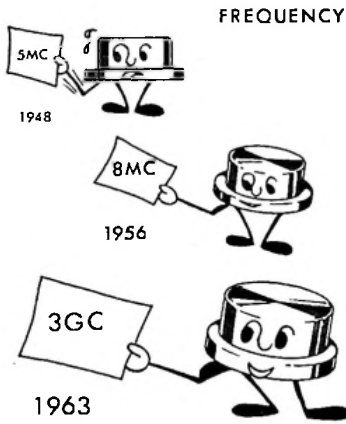

Figure 1-4

Also compare the tube with the transistor on power-handling capabilities. In 1956 the maximum power that any transistor could carry was approximately 5 watts. Transistors which can handle 250 to 300 watts are now available commercially.

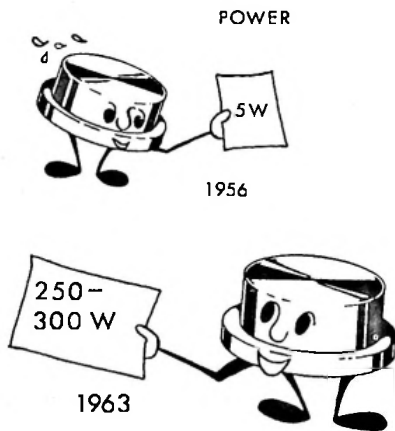

Figure 1-5

One manufacturer recently devised a transistor which is water cooled and will handle 0.5 kilowatt of power. This transistor stands approximately three inches high and is about one inch in diameter and will operate to approximately 8 megacycles. This company expects, in the near future, to build a 1-kilowatt transistor which will be only slightly larger.

WATER COOLED  
TRANSISTOR

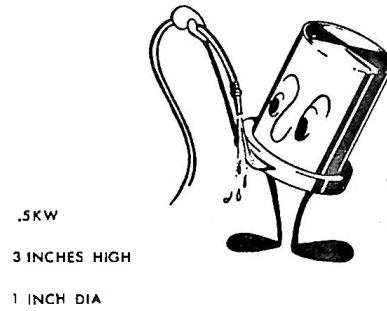

Figure 1-6

Agreed, tubes will still operate at a higher wattage, but transistors are constantly being improved. Remember, the transistor still occupies a much smaller space so that two or three, or even five, transistors might occupy the space of one tube, and these five transistors could well turn out more power than the one tube for the same space.

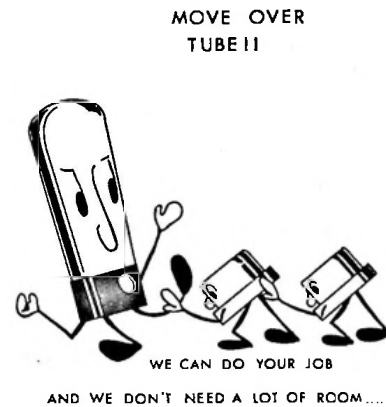

Figure 1-7

Compare the transistor with the tube on lifetime expectancy. Since the transistor does not have filaments to burn open, it has an average lifetime approximately eight times that of the tube.

WE STARTED THIS JOB  
TOGETHER !

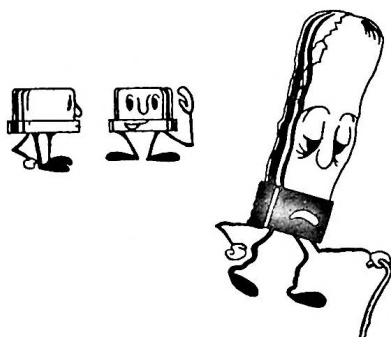

Figure 1-8

Compare the transistor with the tube on efficiency. The transistor again excels because of the lack of filaments which normally use up power in the tube.

EFFICIENCY

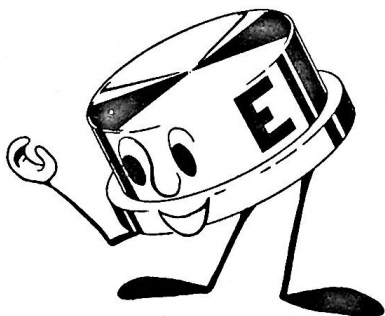

Figure 1-9

Another area in which the transistor excels is ruggedness of construction. Transistors normally are exposed to approximately 20,000 g as a test before they leave the factory. A transistor can be dropped on the floor and picked up, with the possibility of it still being used. Drop a glass envelope tube on the floor, and see how many pieces you have.

RUGGEDNESS

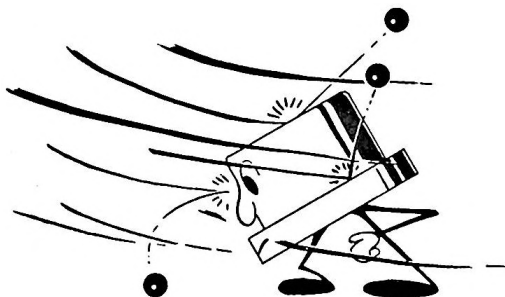

Figure 1-10

The transistor also can be compared pricewise with the tube, and in this area neither excels nor falls behind. There are some tubes which cost considerably less than transistors. There are also transistors which cost less than an equivalent tube. For instance, the 2N404 sells for 49 cents wholesale; an equivalent tube would sell for approximately \$2.45 wholesale. In certain cases, though, the transistor may be much more expensive than the tube.

PRICE

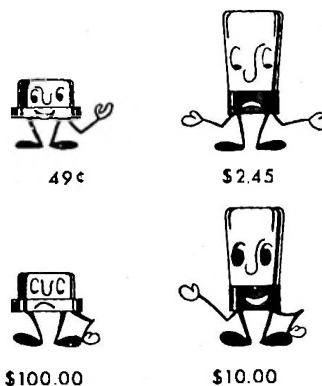

Figure 1-11

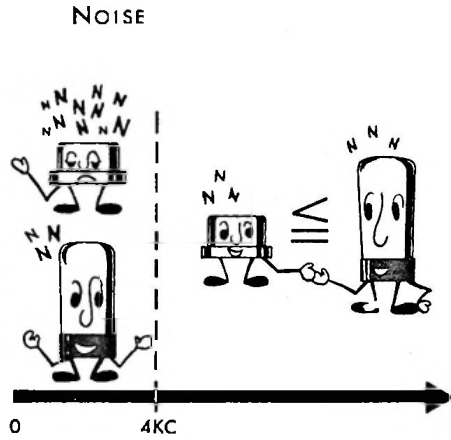

Figure 1-12

Another area of comparison is relative noise. The transistor is noisier than a tube in the lower frequencies, particularly from approximately 4 to 0 kilocycles. At frequencies higher than 4 kilocycles, the transistor is either equal to or less than the tube in noise figure. Remember though that a microphonic transistor is seldom found.

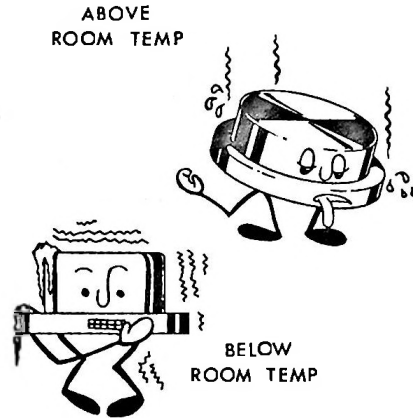

Figure 1-14

This means that any changes in the room temperature will affect the operation of the transistor. A large portion of this course will be utilized in explaining how transistors are temperature stabilized to keep their operating point constant even though there is a large change in ambient temperature.

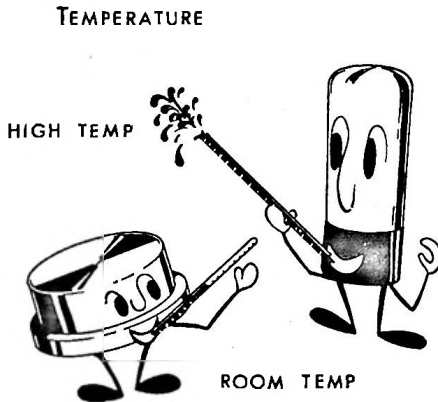

Figure 1-13

Changes in operating temperatures affect transistors much more than tubes. The tube normally is operated at quite high temperatures due to the heating of the filaments, while the transistor is operated at room temperature or at temperatures slightly above room temperature.

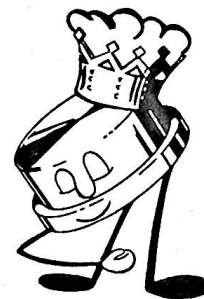

Figure 1-15

Overall, the transistor compares very favorably with the tube and is, without a doubt, here to stay. To maintain his job proficiency, the technician must learn as much as possible about them, or better yet about all types of semiconductors.

DIODES

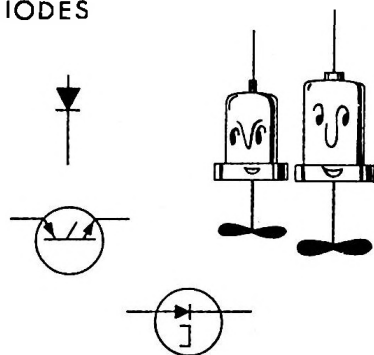

Figure 1-16

Diode Biasing.

Let us continue with section 1 which is a discussion on the basic semiconductor, its uses, nomenclature, and currents. The first item to discuss is the diode.

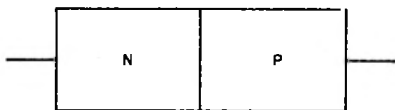

Figure 1-17

The diode is a two-terminal device, as shown in figure 1-17, which consists of a piece of "P" type material and a piece of "N" type material. The diode has peculiar characteristics which allow it to conduct very heavily in one direction while conducting very lightly in the other direction.

In figure 1-18, a potential is applied so that a positive is attached to the "P" type material and a negative is attached to the "N" type material.

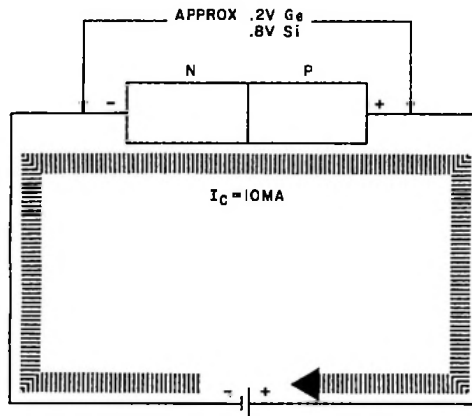

Figure 1-18

The current will flow from the "N" type material to the "P" type material and back to the source. This diode is said to be forward biased, and the current is very large. The voltage drop across a forward-biased diode is approximately 0.2 volt for germanium and 0.8 volt for silicon. This is not the maximum voltage that can ever be across this diode, but the voltage normally is small.

Because this voltage drop is very small, it would be disastrous if a diode were to be connected as shown in figure 1-18 with a battery greater than 0.2 or 0.8 volt since an excessive amount of current would flow. To check a diode for this voltage drop, place a resistor in series with the battery for current-limiting purposes.

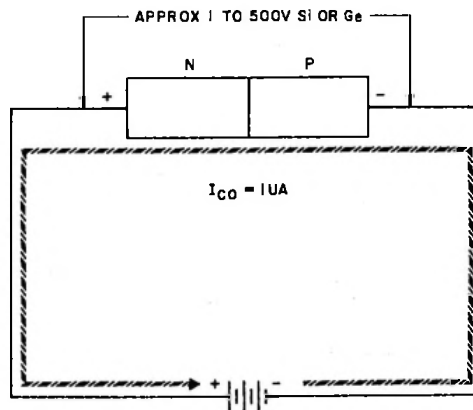

Figure 1-19

## CHAPTER 1

### Diodes

The diode, shown in figure 1-19, has the positive terminal of the battery connected to the "N" type material and the negative terminal of the battery to the "P" type material. This diode is said to be reverse biased, and a very small amount of current is flowing in the diode. This current is due to the leakage of the diode. It is sometimes called leakage current, reverse current, or minority carrier current.

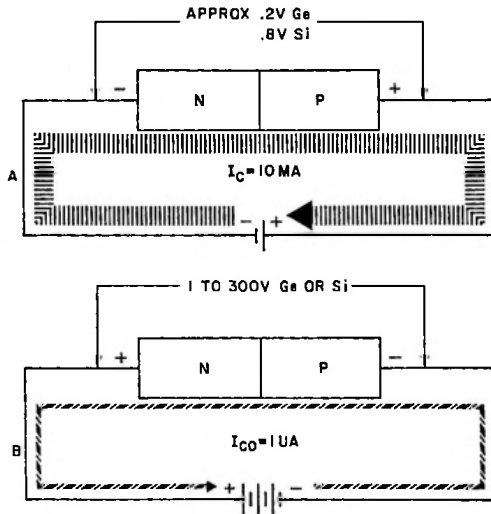

Figure 1-20

Figure 1-20A is a forward-biased diode, and figure 1-20B is a back-biased diode. A good rule to remember in biasing of a diode is that if the polarity of the potential applied to the diode matches the material, as in figure 1-20A, the diode is said to be forward biased, and a large amount of current will flow.

In other words, if the positive terminal of the battery or source is attached to the "P" type material (P for positive) and the negative terminal of the source or battery is attached to the "N" type material (N for negative), the diode is said to be forward biased. If the source is connected, as shown in figure 1-20B, so that the negative terminal of the battery is attached to the "P" type material and the positive terminal of the battery is attached to the "N" type material, this diode is said to be back biased. Note that the "P" for positive and "N" for negative on a forward-biased diode matches the polarity of the source.

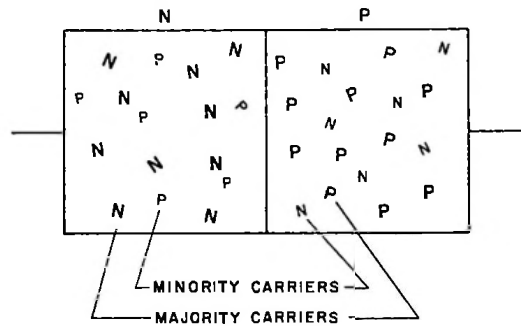

Figure 1-21

The currents which are flowing in a reverse-biased diode, or a back-biased diode as it is sometimes called, are due to minority carriers as shown in figure 1-21.

Minority carriers are a problem in transistors, and they are one of the things which cause a transistor or a diode to become temperature sensitive. In "P" type material, small amounts of "N" type carriers exist. These are in the minority to the "P" type carriers and therefore are called minority carriers. The same is true of "N" type material, except that the minority carriers are small amounts of "P" type carriers. This means that a diode that is back biased to majority carriers is forward biased to minority carriers. This is true because the "N" type material acts slightly "P" and the "P" type material acts slightly "N". The current that flows, called leakage current, will be smaller than the forward current, because the minority carriers do exist in a minority as shown. Minority carriers will start to increase in quantity as temperature increases, therefore, they will increase the current through the device. This will be discussed again in detail in the transistor portion of the course.

Figure 1-22 shows the symbol that normally is used with the diode. This diode is said to be forward biased. Notice that the positive terminal of the battery is connected to the arrowhead of the symbol, while the negative terminal of the battery is connected to the bar. If this diode is forward biased, then the arrowhead must be "P" type material. This is true in all cases. Also current flow in forward-biased diodes is always against the arrow.

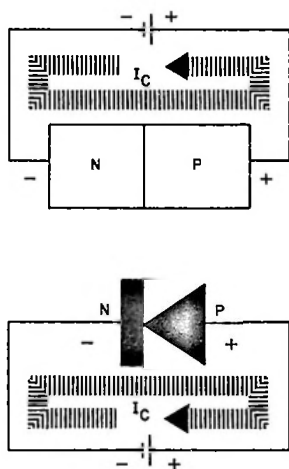

Figure 1-22

Now examine the operating curve of a diode. The entire curve of a diode is shown in figure 1-23, indicating the forward-biased region to the right and the reverse-biased region to the left. Much can be said of each region.

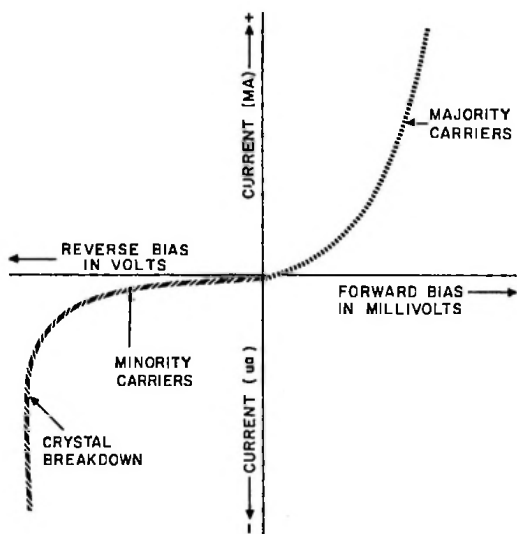

Figure 1-23

First examine the right-hand half of this curve from the vertical line to the right as shown in figure 1-24. Notice that it starts increasing gradually; then it suddenly begins to increase rather rapidly. With an increase in forward-bias voltage, the collector current, which is measured in milliamperes, begins

TYPICAL INSTANTANEOUS FORWARD CHARACTERISTICS  
@ -60°C, +25°C, +150°C (AMBIENT)

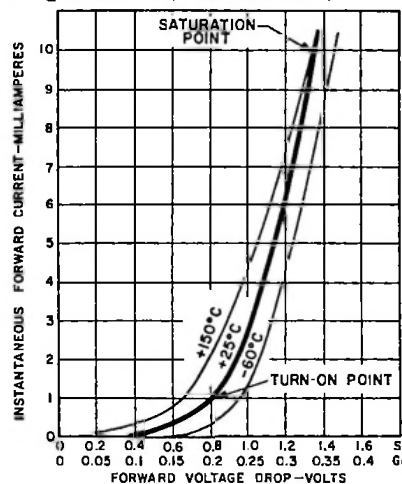

Figure 1-24

to increase rather rapidly at approximately 0.2 volt for germanium and 0.8 volt for silicon.

This is said to be the turn-on point of the diode. Saturation of the diode is reached at approximately 0.35 volt for germanium (Ge) and 1.4 volts for silicon (Si). At this point, the diode is turned on to maximum, and it is conducting as hard as it can without burning up.

Note a slight voltage change will cause the current to increase rather rapidly once the turn-on point is reached. This is one of the reasons that semiconductors are said to be current-driven devices. It is rather impractical to try to control the current through this device by controlling the voltage across it, because a slight change in voltage will make a large change in current. It would also be impractical to try to control the conduction in a tube by controlling the grid current. A tube is said to be voltage driven, therefore, because it is easier to control with voltage, while the transistor or diode is easier to control with current. The alert student may notice that by slightly changing the collector current of the diode a precise control of the voltage drop across the diode is possible.

The curve of a reverse or back-biased diode is shown in figure 1-25. Notice that the horizontal line is plotted in volts, while the vertical line is plotted in microamperes. Just to the left of the zero volt point, there is a slight jump in current at approximately 0.01 volt in the back-biased direction. This is called the low-voltage knee and is the point where the diode is said to be cut off. As the voltage is increased, from this point to 6 volts, notice that the current increases slightly at a linear rate. This is the leakage or minority carrier current of the diode. When 6 volts

TYPICAL REVERSE VOLTAGE

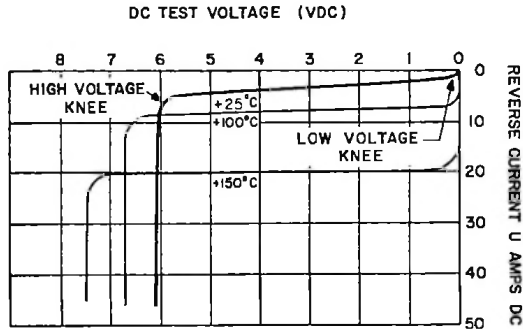

Figure 1-25

is reached, notice that the current suddenly increases. This point is called the high-voltage knee, the zener point, or the breakdown point. All three names are used to describe this point, and all are correct. This sudden increase in current is due to the breaking of atomic bonds in the diode. This does not damage the device permanently as long as the maximum rated reverse current is not exceeded. If the voltage across the diode is lowered below 6 volts and the maximum rated current has not been exceeded, then the atomic bonds will reform.

Notice that once the zener point is reached, no further increase in voltage is possible without increasing the current by an extremely large amount.

VOLTS REVERSE BIAS

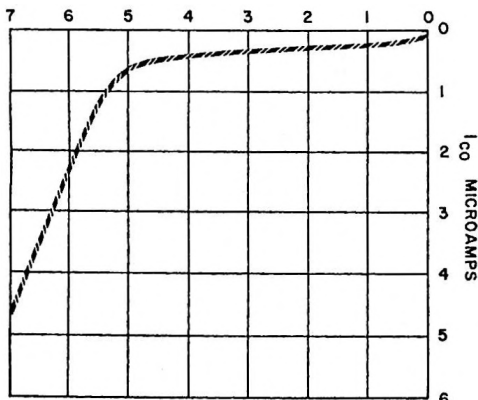

Figure 1-26

All diodes display a reverse bias curve which is similar to that shown in figure 1-25, and some are made to operate in this region. These diodes are called zener diodes, reference diodes, or breakdown diodes. What makes them different from a normal forward-biased diode? The sharpness of this high-voltage knee is one of the important factors. A zener, breakdown, or reference diode has a very sharp high-voltage knee, while a normal diode may have a very soft knee as shown in figure 1-26.

Another important characteristic of the zener diodes, reference diodes, or breakdown diodes is that the junction itself is usually a little larger physically. Why is this necessary? In the forward-biased diode, if one mill is flowing through it at 0.25 volt, the dissipation across the junction will be 0.25 milliwatt. The zener diode usually is operated at higher voltages. This was 6 volts as shown in figure 1-25. One mill, at 6 volts, would be 6 milliwatts. This is a much higher wattage; therefore, the zener diode must be capable of handling this higher wattage.

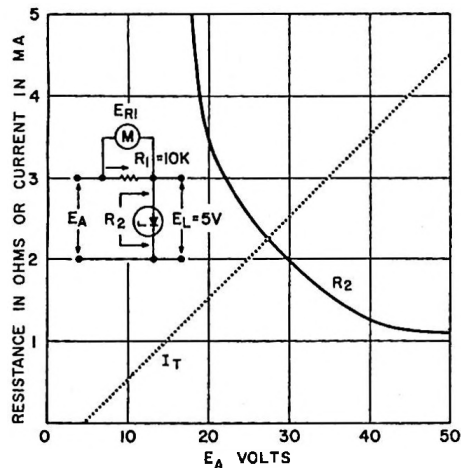

Figure 1-27

The zener diode may be used in place of a VR tube as shown in figure 1-27. A diode which has a breakdown of 5 volts is connected in series with a resistor of 10K and a source of zero to 40 volts. The current through the diode will be such that the current through the resistor, which is in series with it, will drop all but 5 volts, and the voltage across the diode will be only 5 volts. An increase in the voltage of the source will increase the current through the diode, thereby increasing the voltage drop across the resistor. The resistance of the diode decreases at a nonlinear rate as the voltage increases, while the current increases linearly as shown.

Zener diodes may be obtained in many values from approximately 1 volt up to several hundred volts.

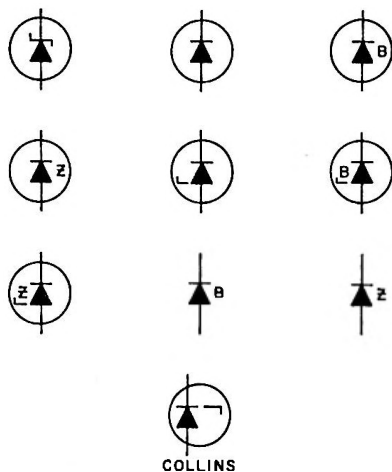

Figure 1-28

The symbols for the zener diode are shown in figure 1-28, with the Collins accepted symbol shown at the bottom. Notice that there are many symbols in use at this time. All of these indicate a zener diode. The direction of current flow in a zener diode is the same as in a back-biased diode, or with the arrow.

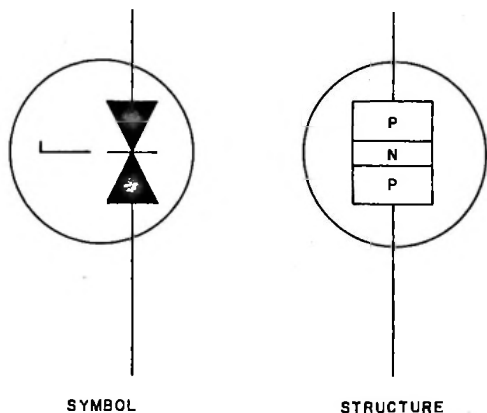

Figure 1-31

Another type of diode which you may encounter is shown in figure 1-29. This diode is known as a back-to-back zener diode. It has no forward-bias current in either direction, but instead is simply two zener diodes connected back to back and will break down and act as a zener no matter in which direction the polarity of this voltage is connected.

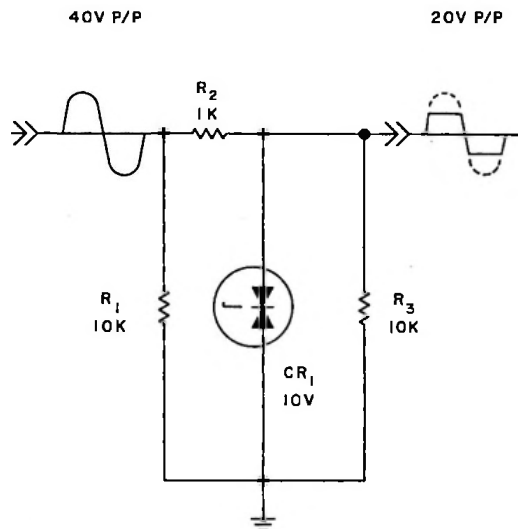
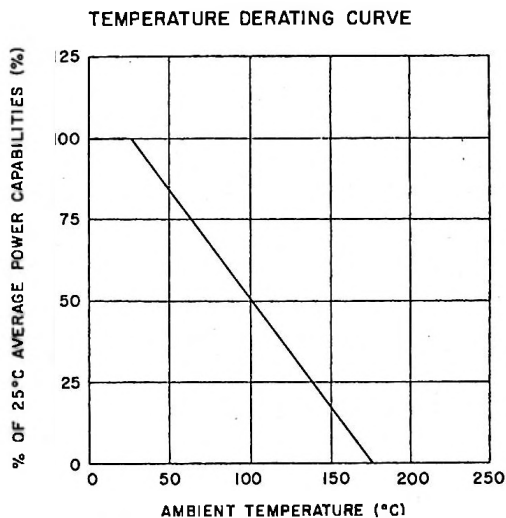

Figure 1-30

These are sometimes used as a limiter as shown in figure 1-30.  $R_1$  is the signal input developing resistor,  $R_2$  acts as a series-limiting resistor for the back-to-back zener  $CR_1$ , and  $R_3$  acts as the output load. When the back-to-back zener is in operation, one junction is forward biased while the other junction is back biased.





CHAPTER 1  
Diodes

Figure 1-31 is a graph for the diode which might explain high failure rates where high ambient temperatures are experienced in the equipment or surrounding area.

This is a plot of percent of rated current or power that is available at a temperature above 25°C. 25°C is the temperature at which all ratings are given. At 100°C, the diode is capable of handling only 50 percent of the rated current or power. This could be the reason that a circuit has a high rate of diode failure.

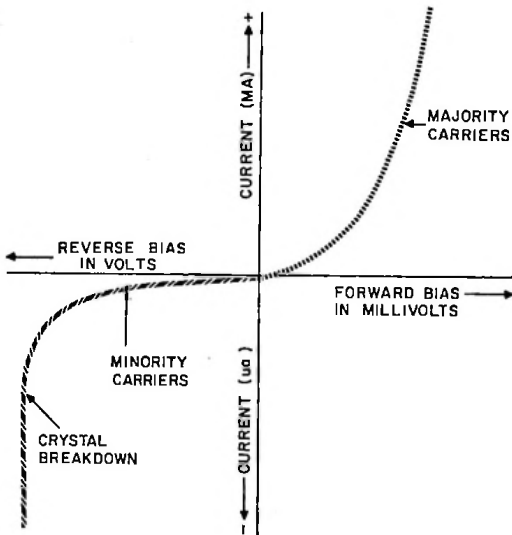

Figure 1-32

Examine again the entire curve of the diode shown in figure 1-32. Note again that the forward-biased current is plotted in milliamperes and the voltage in millivolts, while the back-biased direction is plotted in volts and the current in microamperes. Conventional diodes may be used as rectifiers, detectors, switches, and in any other circuit where a diode tube might be used. Let us examine a few of these uses.

Figure 1-33 shows a bilateral limiter. A bilateral limiter limits the output voltage in both the positive- and the negative-going direction.

Figure 1-34 shows the diode being used as a rectifier. The circuit shown is a bridge rectifier. Note that for either polarity of input, the current through  $R_1$  travels in the same direction.  $CR_1$  and  $CR_3$  conduct on one half-cycle of the input, while  $CR_2$  and  $CR_4$  conduct on the other half-cycle.

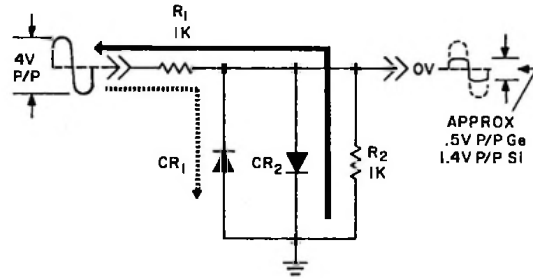

Figure 1-33

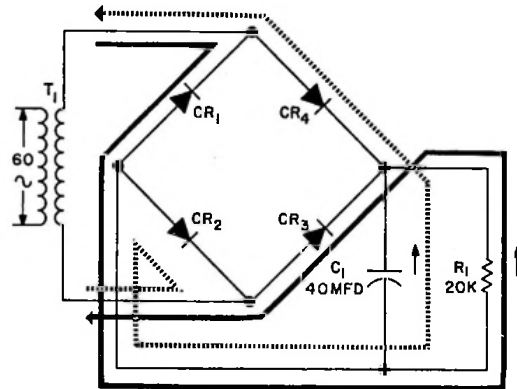

Figure 1-34

Sometimes in rectifying circuits, there are two or more diodes connected in series as shown in figure 1-35.

The diodes are connected in this way to increase the total reverse voltage that the circuit can withstand, and the capacitors act as a voltage divider to ensure equal voltage across each diode during the back-biased condition. This is necessary because most diodes do not have exactly the same back resistance. The  $X_c$  of the capacitors should be about 1 megohm

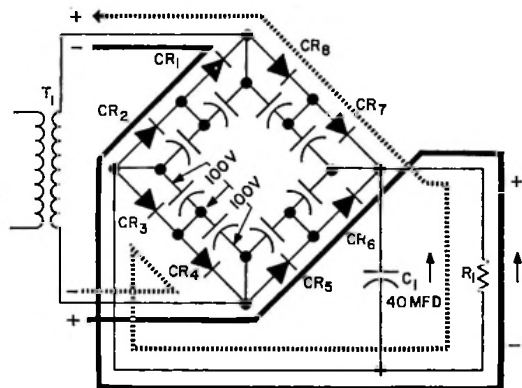

Figure 1-35

each at the frequency of operation. If one diode has a breakdown voltage of 100 volts, two in series would be able to withstand a total voltage of 200 volts.

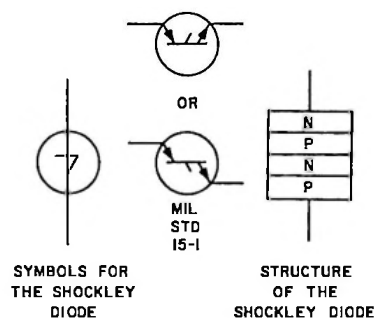

Figure 1-37

There are a few cases where a device that is called a diode does not display the characteristics or is not used in the same manner as the diodes previously discussed.

One such case is the Shockley diode, the symbol for which is shown in figure 1-37. The structure of this device is shown alongside the symbol. As you notice, it is not a two-element device, but rather a PNP, a four-element device. It is called a diode because it has only two leads.

The curve for the Shockley diode and a typical circuit are shown in figure 1-38.

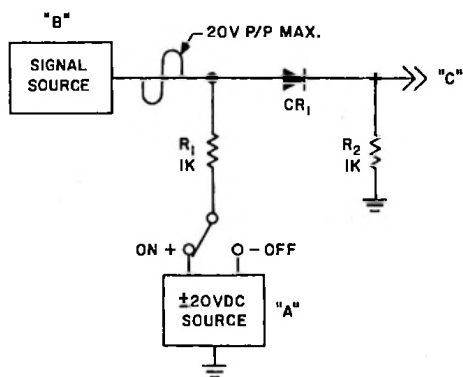

Figure 1-36

Figure 1-36 shows the diode being used as a switch. When the diode is turned on by source A, the signal which comes in from source B can get to point C. The resistance across a forward-biased diode is approximately 2 ohms, while a reverse-biased diode resistance is several K ohms.

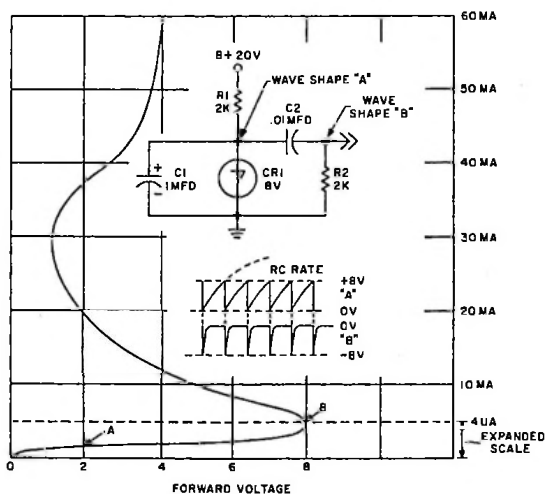

Figure 1-38

CHAPTER 1  
Diodes

Notice that the current increases only slightly as the voltage increases from zero volt to point "B". After point "B", the voltage may decrease and the current continue to increase. This type of curve is known as a negative resistance curve. This does not mean that the resistance becomes less than zero, but only that a decrease in voltage would cause an increase in current; this is the opposite or reverse of normal.

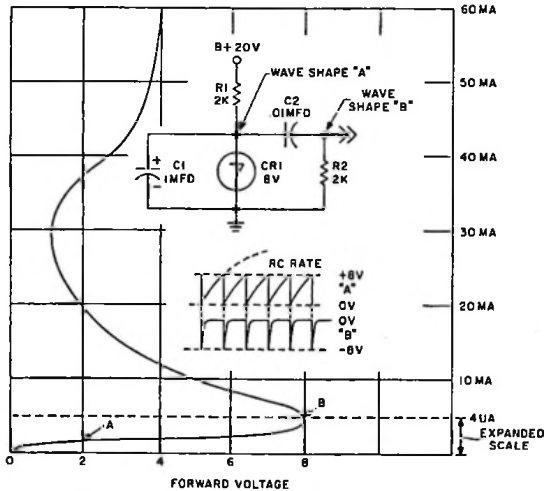

Figure 1-39

Take particular notice of points "A" and "B" and the "30-mill" point.

The Shockley diode, CR<sub>1</sub>, shown has a firing point of 8 volts as shown on the plot of the curve. The operation of this circuit is simple once the basic principles are understood. After power of +20 volts is applied, C<sub>1</sub> starts to charge toward +20 volts through R<sub>1</sub> at an RC rate.

When the voltage across C<sub>1</sub> reaches 8 volts, the Shockley diode, CR<sub>1</sub>, fires or begins to operate in the negative resistance region of its curve. When this happens, the current through CR<sub>1</sub> can increase even if the voltage decreases, and C<sub>1</sub> begins to discharge trying to supply the current necessary to maintain the 8-volt charge. In addition, the current that was previously being supplied to C<sub>1</sub> through R<sub>1</sub> is now being supplied to the Shockley diode, CR<sub>1</sub>. If the maximum current possible to obtain through R<sub>1</sub> falls somewhere on the positive resistance curve of the diode after the 30-mill point, then the diode will lock up in the on condition.

In this case the maximum current that can flow through R<sub>1</sub>, assuming CR<sub>1</sub> is a short, will be 10 mills. This falls about halfway between the 30-mill point and point "B" on the negative resistance portion of the curve. This means that when the Shockley diode, CR<sub>1</sub>, first fires there will be two sources of current, one from the capacitor discharge and the other from the +20 volts through R<sub>1</sub>. This will drive the Shockley diode, CR<sub>1</sub>, to 30 mills for an instant, until capacitor C<sub>1</sub> has discharged completely. When this happens the source of current from the capacitor ceases, and the only source left is from +20 volts through R<sub>1</sub>. As previously stated, the maximum current through R<sub>1</sub> is 10 mills. But at 10 mills the Shockley diode must have approximately 5 volts supplied to it to operate at this current. With 10 mills of current through R<sub>1</sub>, the entire 20 volts is being dropped across it, and zero voltage is being applied to the Shockley diode, CR<sub>1</sub>. CR<sub>1</sub> has discharged C<sub>1</sub> to approximately 1 volt so it heals itself and returns to point "A". This conforms with the voltage and current available at this time. As soon as CR<sub>1</sub> has healed itself and returned to point "A", capacitor C<sub>1</sub> begins to charge, and the entire procedure repeats itself. Wave shape "A" of figure 1-39 is the wave shape that would occur across CR<sub>1</sub>. This signal is coupled through coupling capacitor C<sub>2</sub> and appears as wave shape "B" across the output load, R<sub>2</sub>. Due to the relative sizes of C<sub>1</sub> and C<sub>2</sub>, the effects of C<sub>2</sub> on the charging and discharging of the current is negligible.

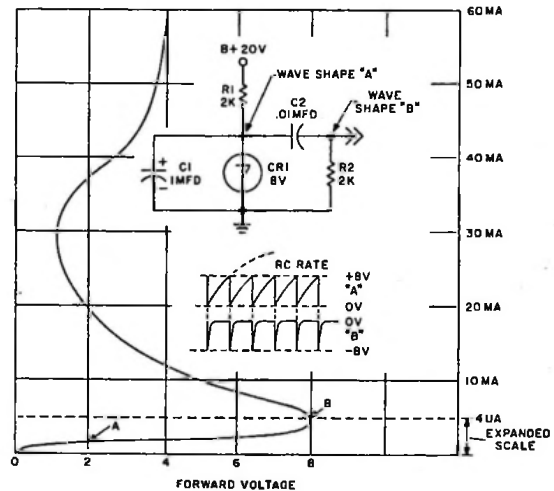

Figure 1-40

In review, reexamine the curve of the Shockley diode as shown in figure 1-40. Note again that the current slowly increases from point "A" to point "B" with an increase in voltage. When point "B" is reached, the current may increase and the voltage decrease until the current reaches 30 mills. Note also that at 10 mills, the maximum current the +20-volt supply

is capable of supplying through  $R_1$ , approximately 5 volts, is necessary to maintain the Shockley fired.

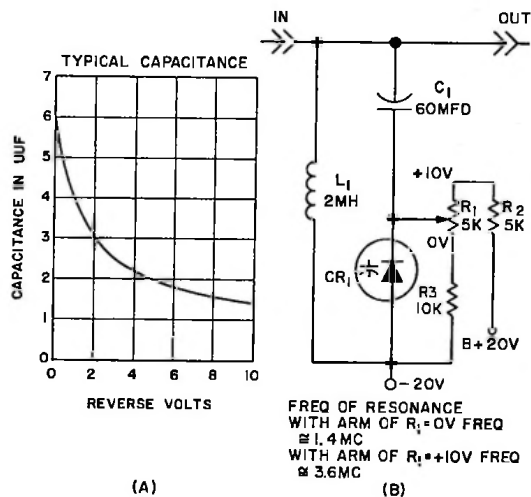

Figure 1-41

Another interesting curve of the diode is shown in figure 1-41A.

This is a curve of the diode capacitance against the reverse voltage. All diodes exhibit this characteristic to some extent, but it is of particular importance in diodes which are named "varicaps," meaning variable capacitor. As the reverse voltage is increased, the capacitance decreases at a non-linear rate. A method of remembering that an increase in voltage decreases the capacitance is to remember that a diode increases leakage current as reverse voltage is increased, and that as a capacitor begins to leak, its capacitance begins to decrease. Figure 1-41B shows a typical circuit that includes a varicap.

$L_1$ ,  $C_1$ , and  $CR_1$  act as a resonant tank circuit.  $R_1$ ,  $R_2$ , and  $R_3$  act as a voltage divider allowing the voltage on the arm of  $R_1$  and across  $CR_1$  to be variable from +10 volts to zero. If the curve in 1-41A is assumed to be for this diode, then the capacitance of the diode will vary from 6 uuf to 1.5 uuf. Because  $C_1$  is 10 times the maximum value of  $CR_1$  and capacitors in series act like resistors in parallel, the total capacitance of the circuit will be variable from approximately 6 uuf to 1.5 uuf. This will cause the frequency of resonance of the circuit to shift from 1.4 mc to 3.6 mc. This circuit can be used as the frequency-determining device in a vfo oscillator.

Time spent in discussing the checking of a diode may save you time and money in the future. A voltohmmeter similar to that shown in figure 1-42



Figure 1-42

usually is sufficient to check a diode, and used correctly it will give you an accurate assessment of the quality of the diode under test and will cause no damage.



Figure 1-43

The front-to-back ratio (in other words, the back-biased resistance over the forward-biased resistance) should be greater than 20 to 1. The back-biased resistance should be 20 times the forward resistance. Any diode which does not meet these specifications should be replaced. A word of caution is in order at this time as point contact diodes should not be tested in this manner, because they may be damaged by excessive currents.

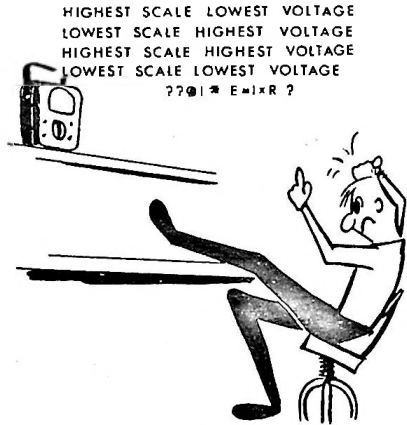

Figure 1-44

Before using a voltohmmeter with which you are not familiar, use another meter to check voltages and polarities applied to the test leads.



Figure 1-45

Always use the lowest voltage available on the highest scale, in that order of importance.

Before using a vtvm for resistance measurements on semiconductors, check known good diodes with it, as most vtvm give inaccurate resistance on semiconductors.

This ends the discussion on diodes.

Review.

Let us review the material covered to this point.

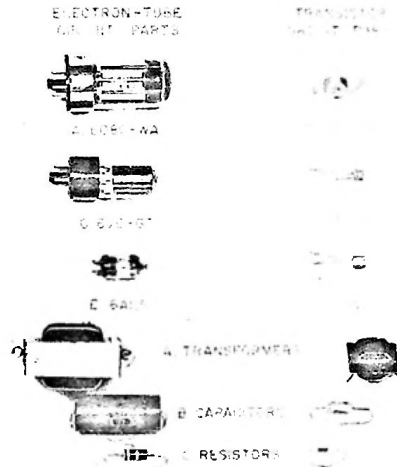

Figure 1-46

It was explained that semiconductors, though not better than the tubes in all cases, did provide an improvement in size, weight, efficiency, and susceptibility to shock.

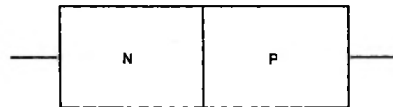

Figure 1-47

It was found that the diode was a two-element device, as shown in figure 1-47, that consisted of a piece of "P" type material and a piece of "N" type material.

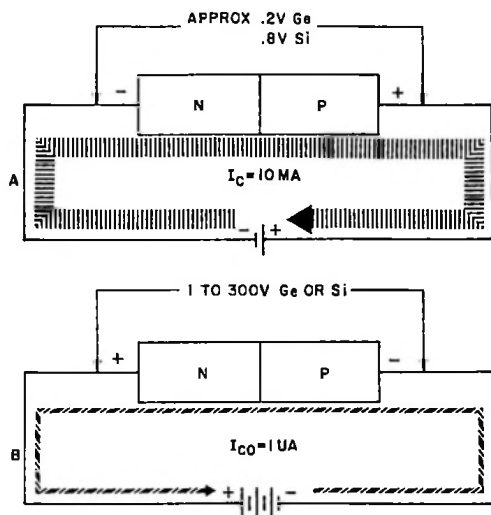

Figure 1-48

Remember the rules for biasing as pointed out in figure 1-48.

Figure 1-48A, a forward-biased diode, indicates that for a forward-biased condition the polarity of the source must match the polarity of the material. Note again that the approximate voltage drop across the diode is 0.2 volt for germanium and 0.8 volt for silicon. Figure 1-48B indicates that for a back-biased condition the polarity of the source must not match the type of material. Note also that there is a very small amount of current flowing called  $I_{CO}$ .

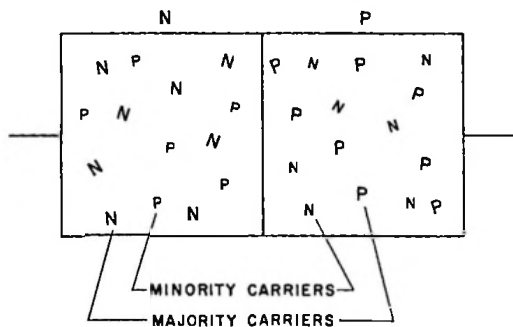

Figure 1-49

As pointed out in figure 1-49,  $I_{CO}$  is due to the minority carriers. Minority carriers are small amounts of "P" type carriers in the "N" region and small amounts of "N" carriers in the "P" region. It was pointed out that a diode that is back biased to majority carriers is forward biased to minority carriers. Remember also that minority carriers increase as temperature increases.

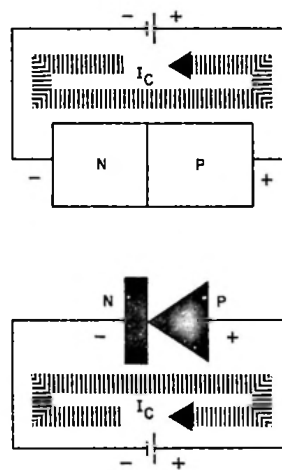

Figure 1-50

Figure 1-50 shows a symbol for the diode and indicates that the solid bar is "N" type material, while the arrowhead is "P" type material. Remember also that current flows against the arrow in a forward-biased diode.

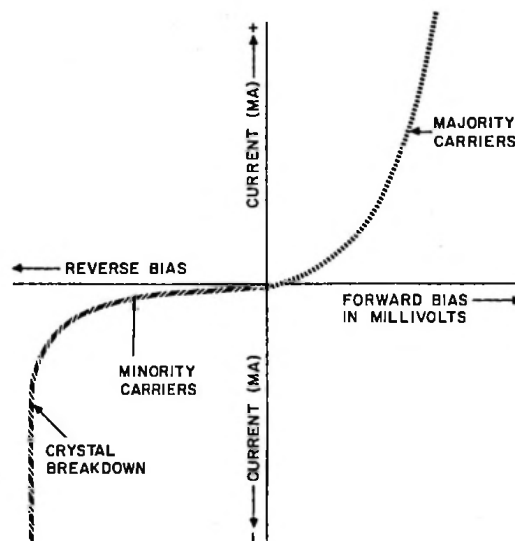

Figure 1-51

CHAPTER 1  
Diodes

Figure 1-51 illustrates the entire curve of a diode showing the back-biased region and the forward-biased region. The right-hand portion of this curve was discussed first. It is shown in figure 1-52.

TYPICAL INSTANTANEOUS FORWARD CHARACTERISTICS  
@ -60°C, +25°C, +150°C (AMBIENT)

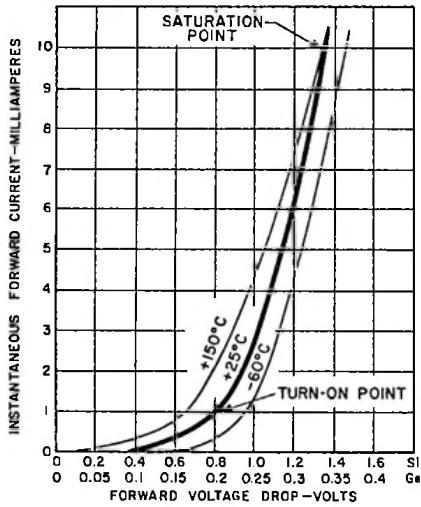

Figure 1-52

Figure 1-52 indicates the typical forward conduction characteristics of a diode. The turn-on point for silicon was found to be 0.8 volt, while the turn-on point for germanium was found to be 0.2 volt. Silicon saturates at approximately 1.4 volts, while germanium saturates at approximately 0.35 volt. It was also pointed out that the semiconductor is a current-driven device due to the impracticability of trying to control the conduction of the device by controlling the voltage across it.

TYPICAL REVERSE VOLTAGE

DC TEST VOLTAGE (VDC)

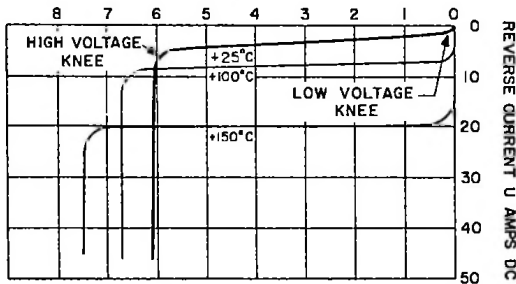

Figure 1-53

Figure 1-53 shows the curve of a back-biased diode and points out the low-voltage knee and the high-voltage knee. The high-voltage knee is sometimes called the breakdown point or the zener point. Some diodes are designed to operate in this back-biased region, and these diodes are called zener diodes, reference diodes, or breakdown diodes. The differences between a regular diode and a zener diode are due to the wattage-handling capabilities and the sharpness of the high-voltage knee. The zener diode can be used in a circuit similar to that shown in figure 1-54.

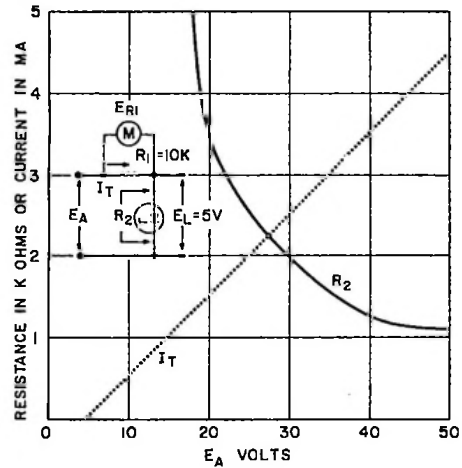

Figure 1-54

Figure 1-54 indicates that if the current is increased at a linear rate, the resistance of the diode will decrease at a nonlinear rate, and that the voltage across the zener diode will remain constant for a large change in the voltage applied. This indicates that a zener diode could be used in place of a VR tube.

Figure 1-55 shows that many symbols are presently in use to indicate the zener diode. Collins symbol for the zener diode is shown at the bottom. Remember that the direction of current flow through a zener diode is the same as leakage current in a regular diode, or with the arrow.

A rather unusual zener diode is shown in its circuit in figure 1-56.

This diode is known as a back-to-back zener diode. The back-to-back zener diode has no forward current, but is simply two zeners connected back-to-back. One junction of a back-to-back zener diode is

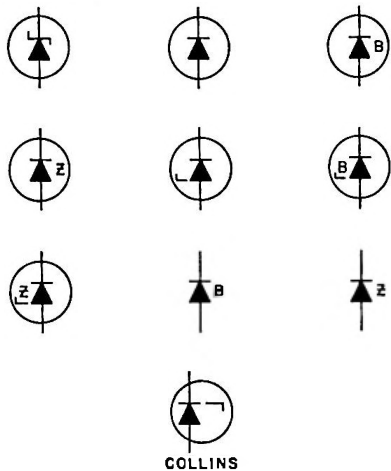

Figure 1-55

always forward biased, while the other junction is backed biased.

The back-to-back diode may be used as a bilateral limiter as shown in the diagram.

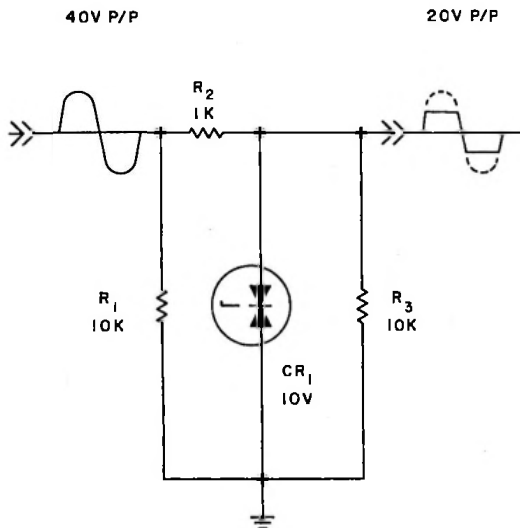

Figure 1-56

The problem of diode failure due to high ambient temperature is explained in figure 1-57.

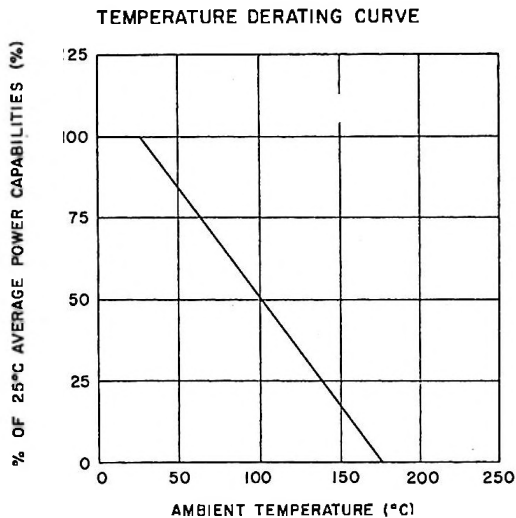

Figure 1-57

Figure 1-57 indicates that if temperature increases, the percent of rated power that is available decreases at a linear rate.

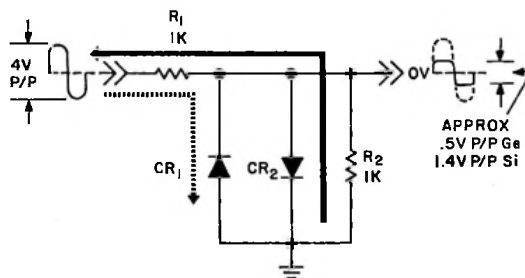

Figure 1-58

Some of the uses of the conventional diode were examined next. Figure 1-58 shows the diode being used as a bilateral limiter which causes clipping of the wave shape equally in the positive and negative direction.



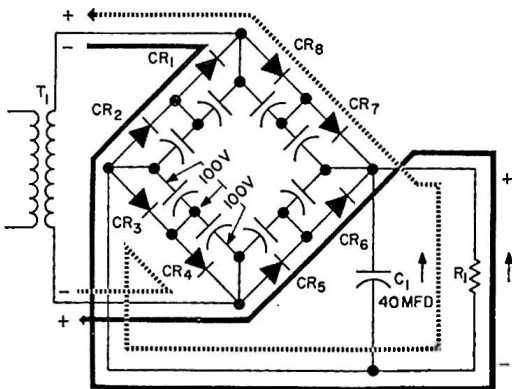

Figure 1-59

Figure 1-59 indicates the use of a diode as a rectifier and how it can be stacked with another to increase the total voltage-handling capabilities. It was explained that the ballast capacitors are necessary around each diode to ensure that both diodes accept an equal amount of the voltage drop through their series resistance.

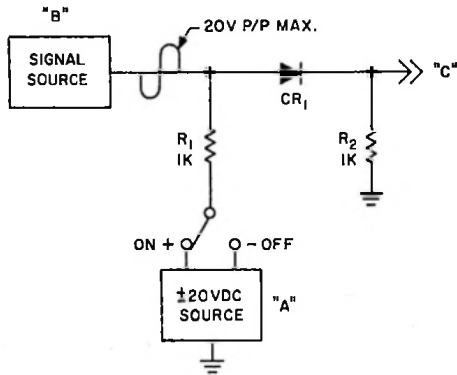

Figure 1-60

The diode also can be used as a switching device as shown in figure 1-60.

When the diode is forward biased, it displays a low resistance and allows the signal to pass; when the diode is backed biased by the source, it acts as a very high resistance and does not allow the signal to pass. Therefore, the diode can be used as an electronically controlled switch.

The curve and circuit of figure 1-61 are associated with the device called a Shockley diode.

The curve indicates that the Shockley diode has a negative resistance region of operation.

If the diode is operated in this negative resistance region, as shown in the circuit, the signals shown in

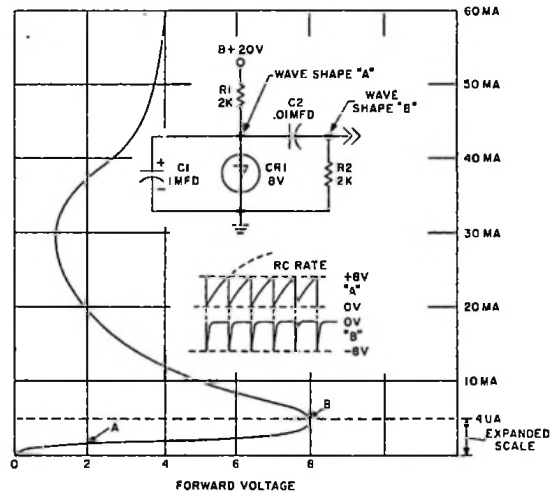
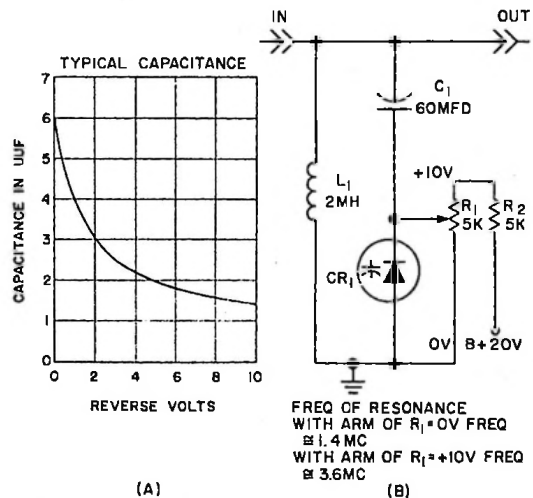

Figure 1-61

wave shape "A" and "B" result. This is due to the charging of  $C_1$  through  $R_1$ , and then the subsequent discharging of  $C_1$  through  $CR_1$  along with the current from  $R_1$ .

The diode also may be used as an electronically variable capacitor.

Figure 1-62 shows an example of the typical capacitance versus reverse voltage of a diode and a typical circuit where the diode may be used. This type of diode is called a varicap. By varying the back bias on this diode it was found that the capacitance of this circuit will also vary, increasing or decreasing the frequency of resonance.



(A)

(B)

Figure 1-62

### Section 1 Work Problems

Some of the following problems are arranged so that you may conveniently underscore the correct words, or fill in the blanks, or answer thought questions in your own words.

1. What are majority carriers?
2. What are minority carriers?
3. (Majority or Minority) carriers cause current to flow in a reverse-biased diode.
4. A high current flows in a reverse-biased diode. (True or False)
5. A junction diode is a three-terminal device. (True or False)
6. A diode is said to be \_\_\_\_\_ biased if the polarity of the supply voltage is opposite to that of the type of material.
7. The proper method of checking a diode is to apply a high d-c voltage to it and measure the voltage drop. (True or False)
8. A diode is said to be \_\_\_\_\_ biased if the polarity of the supply matches the type of material.
9. As temperature increases, the number of minority carriers (increases or decreases).
10. The current carriers in a forward-biased diode are (minority or majority) carriers.
11. Using the curve shown in figure 1-24 for 25°C, find the resistance for germanium and silicon diodes at the following currents and voltages:

- | <u>Ge</u>    |       |
|--------------|-------|
| A. 0.15 volt | _____ |
| B. 1 mill    | _____ |
| C. 2 mills   | _____ |
| D. 0.25 volt | _____ |
| E. 0.3 volt  | _____ |

- | <u>Si</u>    |       |
|--------------|-------|
| A. 0.6 volt  | _____ |
| B. 0.8 volt  | _____ |
| C. 2 mills   | _____ |
| D. 1.0 volt  | _____ |
| E. 1.2 volts | _____ |

12. Plot the values found in problem 11 for germanium and silicon diodes on the graphs provided in figure 1-63.

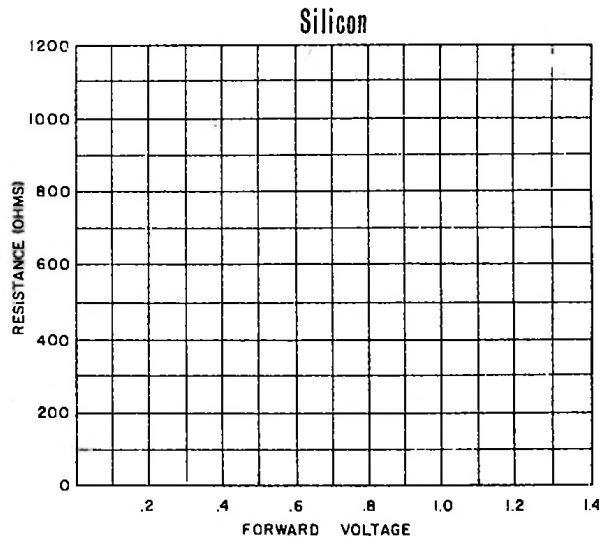
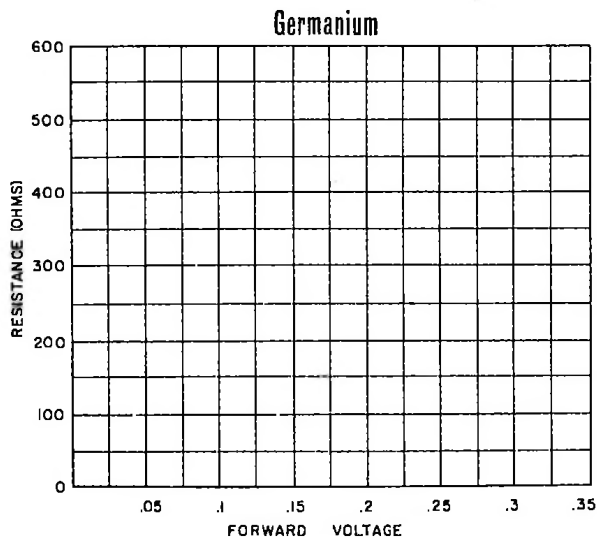

Figure 1-63

## CHAPTER 1

### Diodes

13. The two basic differences between a zener diode and a regular diode are \_\_\_\_\_ capabilities and \_\_\_\_\_ knee.
14. The sudden increase in current at the zener point is due to the \_\_\_\_\_ bonds.
15. If the current is increased through a zener diode at a linear rate, the resistance (decreases or increases) at a (linear or nonlinear) rate.
16. Draw a picture showing the structure of a back-to-back zener diode.
  
17. If a diode is rated at 10 watts at 25°C, how much wattage would it be capable of dissipating at 100°C? Use figure 1-31 as a reference.
18. The back-to-front resistance ratio of a diode should be at least \_\_\_\_\_ to \_\_\_\_\_ if the diode is to be considered good.
19. Why are two or more diodes sometimes placed in series in rectifier circuits?
20. In figure 1-39 if the capacitance of  $C_1$  is increased, what will happen to wave shape "B"?
21. If you intend to use a varicap in a circuit that displays a curve like that shown in figure 1-41A and the maximum change available in the bias voltage is 2 volts, at what point on the curve should the varicap be biased to obtain the maximum change in capacitance?
22. The Shockley diode is a \_\_\_\_\_ element device.
23. Before using a voltohmmeter to check a diode, what precautions should you take?
24. What basically causes the semiconductor diode to be more efficient than a tube?
25. A zener diode may be operated in the forward-biased region as a regular diode with no damage. (True or False)

When you have reviewed all the material in chapter 1 and answered the preceding problems to the best of your ability, you are ready to proceed to the next tape-slide presentation where the answers to the above problems will be given and explained.

## transistor biasing and configurations

### Introduction.

Chapter 2 presents a discussion on biasing a transistor and the three basic configurations. This portion of chapter 2 consists of an introduction to the three-element device, the transistor. The polarity of bias necessary for normal operation is shown and explained, and the ratios of each of the currents found in a transistor are discussed. Additionally, the common base configuration is discussed in detail, with computations for voltage gain, resistance gain, power gain, and phase shift.

### Transistor Biasing.

It can be shown that the transistor, a three-element device, is exactly the same as a back-to-back zener in construction. In figure 2-1, the transistor is shown as a piece of "P", a piece of "N", and a piece of "P" type material. The difference between this device and a back-to-back zener is in the additional lead connected to the "N" type material labeled "B".

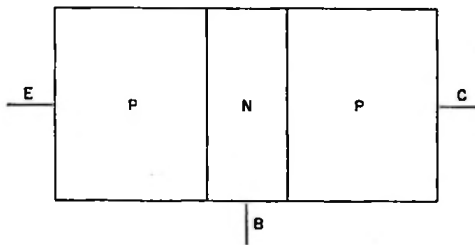

Figure 2-1

These three blocks of material make up two PN junctions. Note that if a battery were connected, as shown in figure 2-2, from pin E to pin B with a positive on E and a negative on B, this portion would act as a forward-biased diode, and a large current

would flow. If a battery were connected, as shown in figure 2-3, from pin B to pin C with the positive terminal of the battery connected to pin B and the negative terminal to pin C, this portion would act as a back-biased diode, and very small amount of current would flow.

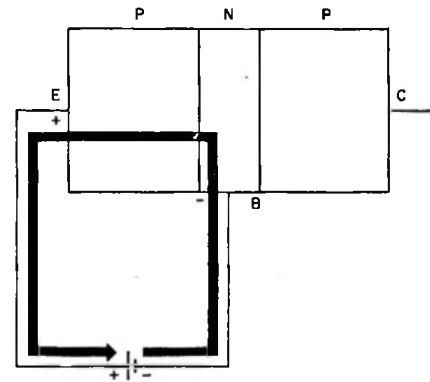

Figure 2-2

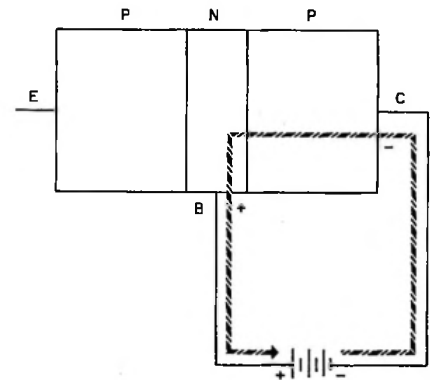

Figure 2-3

CHAPTER 2  
Transistor Biasing and Configurations

By combining figure 2-3 and figure 2-2, the transistor with normal bias is obtained as shown in figure 2-4.

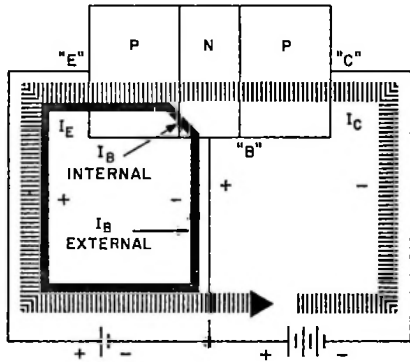

Figure 2-4

The "E" stands for emitter, the "B" stands for base, and the "C" stands for collector. Notice that an additional current is shown flowing from the collector to the emitter. This current is called collector current and is labeled " $I_C$ ". When a small amount of base current, called  $I_B$ , is caused to flow from the base to the emitter, a large amount of current flows from the collector to the emitter. This basic fact is the reason that a transistor can be used as an amplifier. The collector current,  $I_C$ , and the base current,  $I_B$ , combine in the base region and form what is called the emitter current. The emitter current labeled " $I_E$ " is equal to the internal base current,  $I_B$ , plus the collector current,  $I_C$ .  $I_E$  is the total current flowing in the circuit. A differentiation is made between the external base current,  $I_B$ , and the internal base current, as the external base current may not be equal to the internal base current. This will be explained in the following material. Note that no reverse current is shown flowing in figure 2-4.

Figure 2-5 shows that if reverse current, called  $I_{CBO}$ , is present it will be flowing in the opposite direction of the external base current,  $I_B$ . It is impossible to have current flowing in two directions in the same wire at the same time. Does the reverse current,  $I_{CBO}$ , exist then? If it does exist, where is it going? The first question can be answered by examining figure 2-6, which shows that it does exist and can be measured by opening the emitter lead. The reverse current,  $I_{CBO}$ , means current from collector to the base with the emitter open.

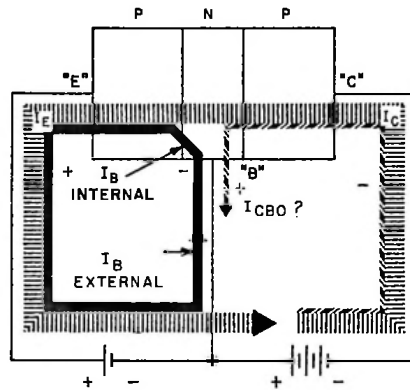

Figure 2-5

The question may come up then, "Does this current exist only with the emitter open?" No, this current exists at all times. Remember it is due to minority carriers which are present at all times and increase in quantity as the temperature increases. As shown in figure 2-7, this current is trying to flow in the direction opposite to the external base current,  $I_B$ .

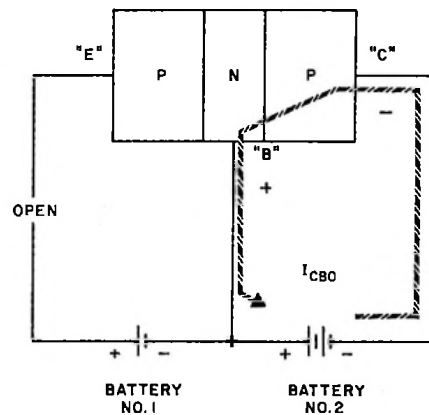

Figure 2-6

It is apparent then that the current flowing in the base lead must be the algebraic sum of the reverse current,  $I_{CBO}$ , and the base current,  $I_B$ , that would flow if no  $I_{CBO}$  existed. This algebraic sum is called the external  $I_B$  and usually flows in the direction shown for  $I_B$ , since  $I_B$  is normally much larger than  $I_{CBO}$ .

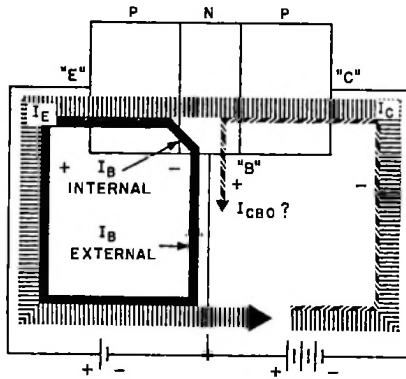

Figure 2-7

The fact still remains that minority carriers are carrying current into the base region, and this current must go someplace, as it cannot continue to enter the base region without leaving the base region.

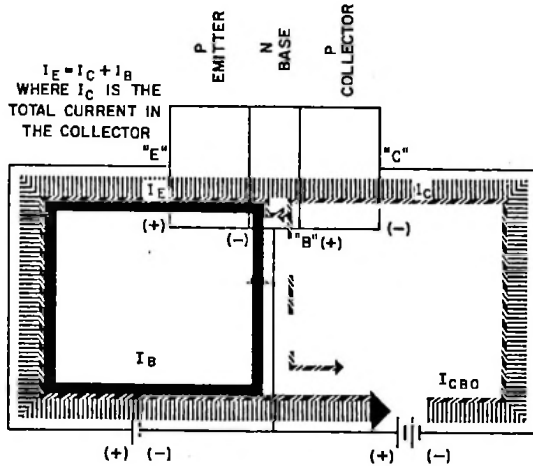

Figure 2-8

Figure 2-8 shows that this current, although trying to flow against the external base current,  $I_B$ , as shown by the dotted line, actually continues on toward the emitter adding to  $I_B$  internally. Therefore, the reverse current,  $I_{CBO}$ , adds to the internal  $I_B$ , and the internal  $I_B$  is the combination of a portion of the  $I_B$  that would normally flow with no  $I_{CBO}$  plus  $I_{CBO}$ . Stated another way, the internal  $I_B$  is equal to the external  $I_B$  and  $I_{CBO}$ . In a bias arrangement, like that shown in figure 2-8, where the voltage across the junction must be constant due to the battery tied across it, the internal base current,  $I_B$ , will remain constant, and the external

$I_B$  will decrease as the reverse current,  $I_{CBO}$ , increases. This must be true, because if the internal  $I_B$  were to increase or decrease, the voltage across the base-emitter junction would have to increase or decrease respectively. This cannot happen with a constant voltage source, a battery in this case, tied across the base-emitter junction. If the voltage across the junction remains constant, then the current through the junction must remain constant, and if  $I_{CBO}$  adds to the internal  $I_B$ , then the external  $I_B$  must decrease as  $I_{CBO}$  increases. You may ask the question, "Why doesn't the collector current,  $I_C$ , add to the internal emitter current,  $I_E$ ?"

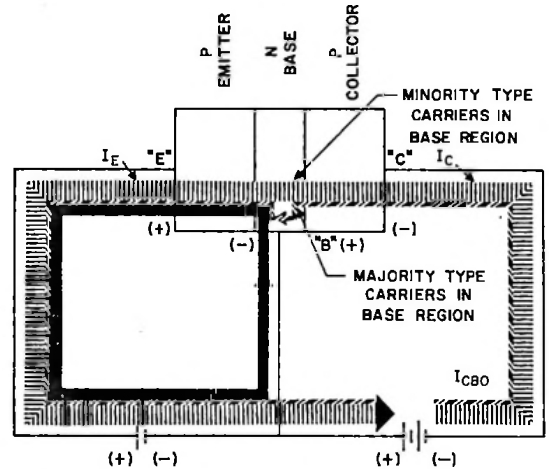

Figure 2-9

The answer to this, as is shown in figure 2-9, is that the collector current,  $I_C$ , is due to majority carriers in the collector region which then are necessarily minority carriers in the base region since the base is made of opposite type material. The reverse current,  $I_{CBO}$ , on the other hand, is due to minority carriers in the collector region which then are necessarily majority carriers in the base region. Since the base current,  $I_B$ , is due to majority carriers in the base region, only reverse current,  $I_{CBO}$ , which is due to carriers which are majority type when injected into the base, can add to base current  $I_B$ .

The current in the collector lead is called  $I_C$ , and  $I_C$  contains  $I_{CBO}$ . Because  $I_{CBO}$  is flowing in the same direction as the majority carrier current in the collector, it adds to the majority carrier current, and the collector current,  $I_C$ , will increase as the reverse current,  $I_{CBO}$ , increases. The emitter current,  $I_E$ , will also increase as  $I_{CBO}$  increases. Hereafter  $I_C$  will be referred to as the total current flowing in the collector lead, including  $I_{CBO}$ , and  $I_E$  will be the total current flowing in the emitter lead and will be equal to the total collector current,  $I_C$ , including the reverse current,  $I_{CBO}$ , and the base current,  $I_B$ . The effects of  $I_{CBO}$  on an operating circuit will be explained in detail in the chapter on bias stabilization.

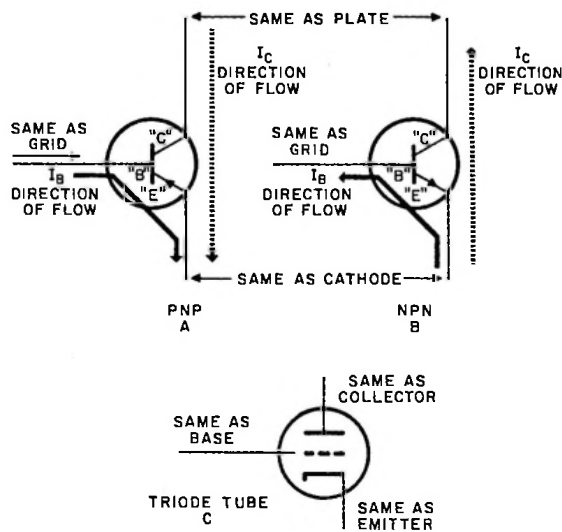

Figure 2-10

Observe figure 2-10 which shows the transistor symbol and a comparison of the different parts of the transistor to the triode tube.

Figure 2-10A shows the symbol for a PNP transistor. The lead with the arrow labeled "E" is the emitter lead. The lead labeled "B" that is connected onto the large flat area is called the base lead, and the lead labeled "C" is called the collector lead.

The direction that the arrow on the emitter is pointing is important as it indicates the type of transistor, PNP or NPN. If the arrow points toward the base, it is a PNP. Figure 2-10B is the symbol for an NPN transistor. Again the emitter is the lead with the arrow. The base lead connects to the large flat area, and the collector is labeled "C." In this case, though, the arrow is pointing away from the base region. If the arrow points toward the base, the transistor is a PNP; if the arrow points away from the base, the transistor is an NPN. Current flow in each case is always against the arrow. This means that current flow in a PNP is from the collector to the emitter, while the current flow in an NPN is from the emitter to the collector. The transistor operates similar to the triode tube shown in figure 2-10C.

The emitter of a transistor compares to the cathode of a tube and acts much the same, while the collector of a transistor is much the same as the plate of a tube. The emitter of a transistor may be considered a cathode, while the base may be considered the grid, and the collector may be thought of as the plate of a triode.

So far all the transistors have been shown biased with two batteries. Note the transistor in figure 2-11A which obtains bias from one source. Ground is applied at the junction of  $R_E$  and  $R_1$ , while B- is connected to the junction of  $R_2$  and  $R_L$ . The transistor is a PNP because the arrow points toward the base.

### Transistor Currents.

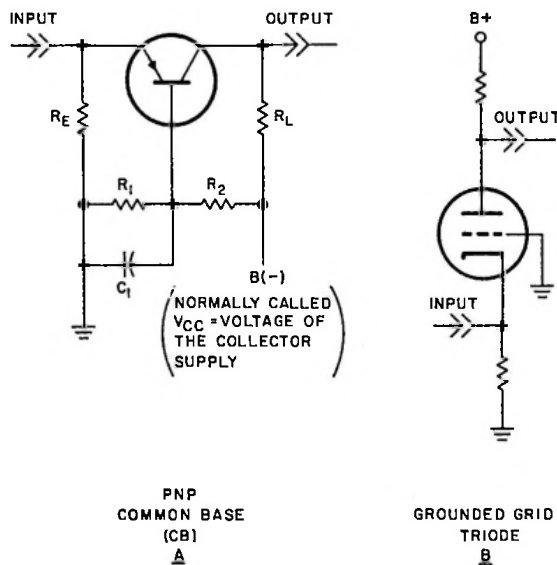

Figure 2-11

Because the ordinary transistor has three leads, there are three possible ways of connecting it in a circuit. These are common base, or grounded base; common emitter, or grounded emitter; and common collector, or grounded collector. The transistor shown in figure 2-11A is connected in a common base, CB, configuration. Why? Because the base is a-c grounded through  $C_1$  and is common to the input and the output. The input comes in on the emitter, and the output is off the collector. The only item which can be common to both the input and output is the third item, which is the base that is a-c grounded through  $C_1$ . This compares directly to the grounded-grid triode circuit shown in figure 2-11B.

Examine the circuit to see if it is biased correctly. A method of determining the polarity of bias on a transistor is to determine the type of transistor, in this case, a PNP; and, as shown in figure 2-12, to write in the letters "P-N-P" on the back side of the symbol.

As shown in figure 2-13, starting at the emitter, using the same polarity as the emitter material indicates, which in this case is "P" for positive, mark in the polarities. In this example we have a positive on the emitter to negative on the base, and a positive on the

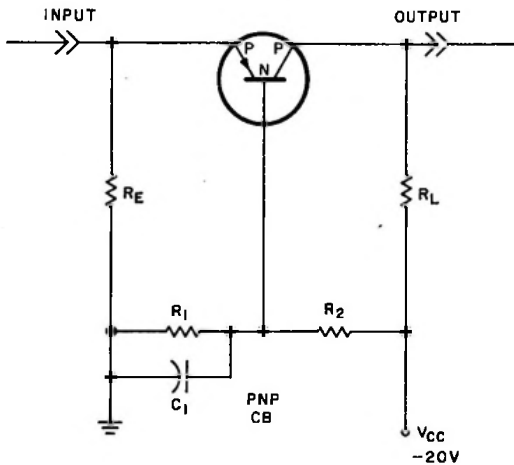

Figure 2-12

base to negative on the collector. Notice that the polarities go in series.

It appears that two batteries are desired to be connected in series and that the polarity of the terminal of the battery connected to the emitter matches the material. In this case, with "P" type emitter material, the positive terminal of a battery should connect to this point. In series from the emitter, the polarity goes positive, negative, positive, negative. This is the bias that can be expected across a PNP-type transistor. This rule, of matching the polarity of the bias to the emitter material, holds true for NPN

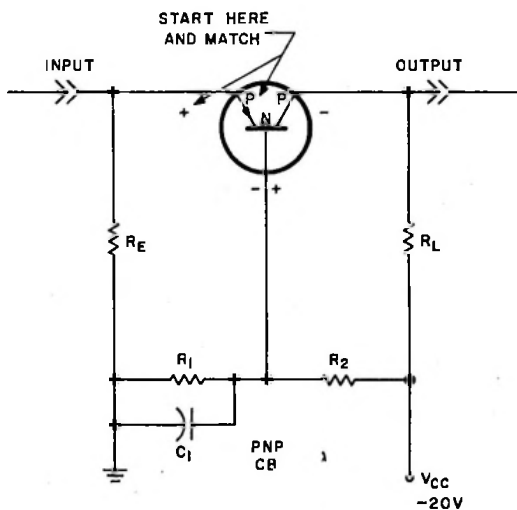

Figure 2-13

as well as the PNP, as will be shown shortly. Examine this PNP common base, CB, circuit to see if it has the correct bias. Instead of two batteries, a voltage divider consisting of  $R_1$  and  $R_2$  is used.

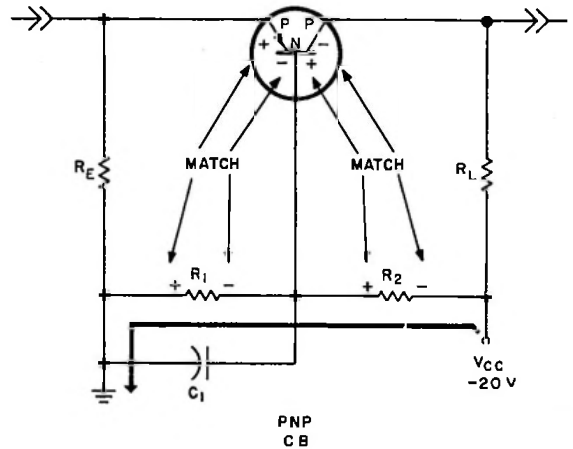

Figure 2-14

Figure 2-14 indicates that current flow in this circuit flows from B- through  $R_2$ , through  $R_1$ , to ground. Note that the polarities across each resistor match the polarity of the bias desired for the transistor.

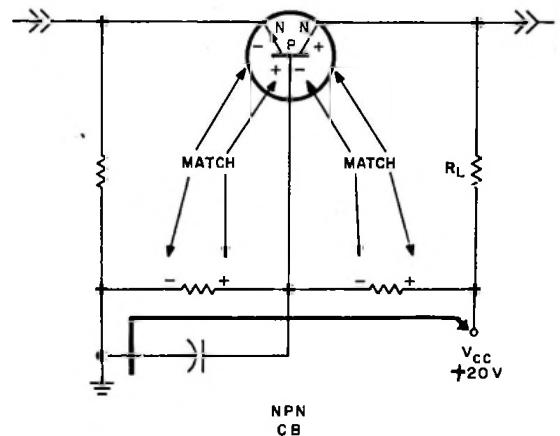

Figure 2-15

Figure 2-15 shows the bias for an NPN. As can be seen, it is the same as the PNP, with the bias polarities and current reversed.



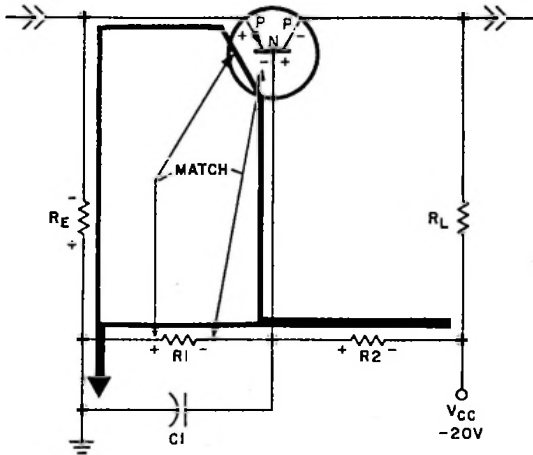

Figure 2-16

An examination of figure 2-16 will show that the bias of figures 2-14 and 2-15 are correct.

In series with the base-emitter junction is  $R_E$ , the emitter resistance. The voltage across  $R_E$  is dependent upon the voltage on the base, so it cannot be greater than the base voltage and must be of the same polarity. If the voltage across  $R_E$  is greater than the voltage on the base due to the collector current,  $I_C$ , then the transistor will be backed biased and there will be no  $I_C$ ; therefore, this condition is impossible. The emitter current is dependent upon the current flowing in the base. The current flow is from the base to the emitter through  $R_E$  to ground, in parallel with  $R_1$ . This transistor is connected properly for forward bias of the base-emitter portion.

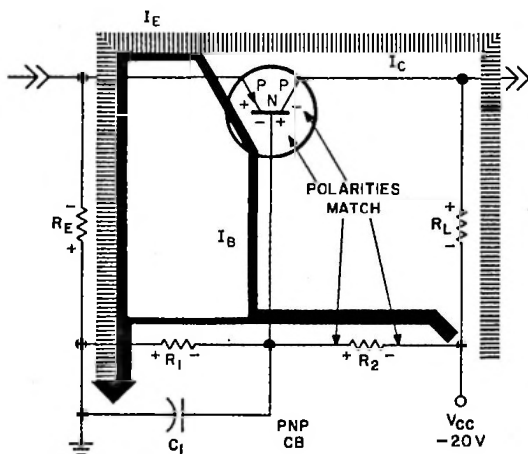

Figure 2-17

Examine the back-biased section, or the base-collector junction in figure 2-17.

The base-collector junction plus  $R_L$  is in parallel with  $R_2$ . Therefore, the polarity across  $R_2$  will be across the base-to-collector junction, or the base will be positive with respect to the collector, and the transistor will be biased correctly.

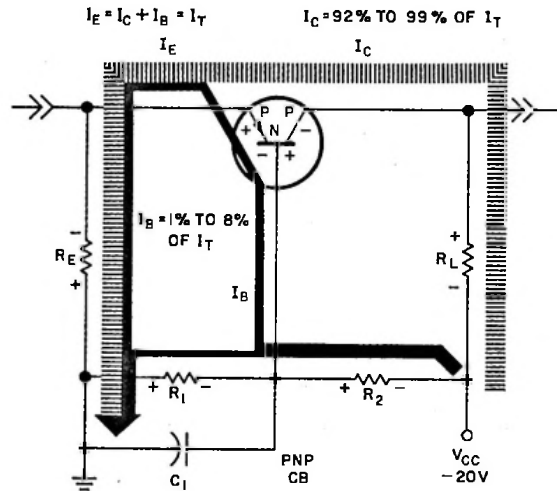

Figure 2-18

Figure 2-18 illustrates the different current flows in a transistor and the ratios of one to another. As previously stated, the current in the collector lead is called  $I_C$ . The current in the base lead is called  $I_B$ , and the current in the emitter lead is called  $I_E$ . As shown in the upper left-hand corner of figure 2-18,  $I_E$  is equal to  $I_C + I_B$ . This means that  $I_E$  is the total current flowing in the circuit. As shown in the upper right-hand corner of figure 2-18,  $I_C$  is equal to between 92 and 99 percent of  $I_T$ , or  $I_E$ . In the middle of the diagram it is shown that  $I_B$  consists of the rest of the total current which will be 1 to 8 percent of  $I_T$  or  $I_E$ . This means that 92 to 99 percent of the current,  $I_E$  or  $I_T$ , flowing in the emitter comes from the collector, and only 1 to 8 percent comes from the base.

Note the use of the term " $I_T$  or  $I_E$ ". This is to emphasize that  $I_E$  is equal to the total current flowing in the circuit.

### Transistor Circuit Characteristics

Now that you have been introduced to bias and current flow, let us take a general look at some of the characteristics exhibited by the different transistor circuits.

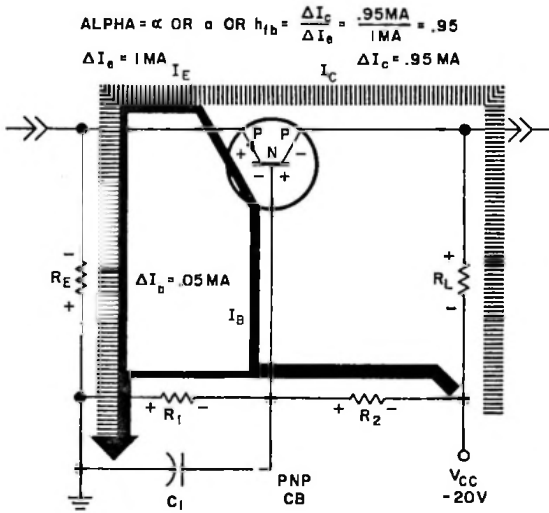

Figure 2-19

Since transistors are current rather than voltage devices, when we speak of gain we are interested in ratios between two currents. Alpha represents the ratio of delta  $I_C$  divided by delta  $I_E$ , where delta  $I_C$  is the change in collector current for a change in the emitter current, delta  $I_E$ . In short, alpha is the forward short circuit current gain for the common base configuration.

Notice that lowercase subscript letters are used to indicate emitter and collector currents, while all previous subscripts were capital letters. By convention, capital letter subscripts indicate d-c, or quiescent functions, while lowercase subscripts are used to indicate an a-c, or operating function.

Alpha is sometimes found in transistor manuals or characteristic data charts. However, it is usually found as  $h_{fb}$ . The "h" stands for hybrid parameters. Hybrid parameters were developed and are used by transistor manufacturers to indicate the values of the internal elements of transistors. The subscript "f" stands for forward current transfer ratio, and the subscript "b" indicates a common base configuration. Therefore,  $h_{fb}$  in its entirety reads "hybrid parameter, forward current transfer ratio of a common base configuration."

The value of alpha is a function of the transistor and is not dependent upon the value of the circuit components in any way.

Figure 2-19 illustrates a computation to find alpha. We assume a signal input that will cause a change in the emitter current,  $I_E$ , of 1 mill. A corresponding change of 0.95 mill will occur in the collector current,  $I_C$ . Alpha in this case is equal to 0.95 divided by 1 which equals 0.95. Alpha can never be greater than 1. This becomes obvious when you recall that there must be a certain amount of base current,  $I_B$ , flowing before any collector will flow.

The collector current,  $I_C$ , is dependent upon the base current,  $I_B$ . In this case, with an alpha of 0.95, 0.05 mill of base current change, delta  $I_B$ , occurs for a 1-mill change in the emitter current and a 0.95-mill change in the collector current. As previously stated the common base configuration compares exactly with the grounded-grid tube circuit. Keep this in mind when examining the following diagrams to see what the common base configuration will do.

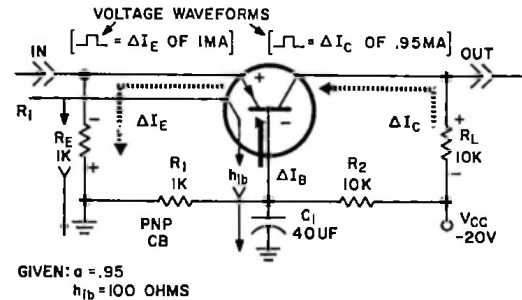

$$\left[ \begin{aligned} R_i &\approx \frac{R_E \times h_{fb}}{R_E + h_{fb}} \\ h_{fb} &\approx 25 \text{ TO } 100 \text{ OHMS} \\ \text{IF } R_E \approx 10 \times h_{fb} \text{ THEN } R_i &\approx h_{fb} \\ R_i &\approx 100 \text{ OHMS} \end{aligned} \right]$$

Figure 2-20

Figure 2-20 shows the computations for input resistance of a common base configuration. The input signal on the emitter sees the parallel resistance of  $R_E$ , and the base-emitter resistance,  $h_{fb}$ , in series with the a-c impedance of  $C_1$  to ground.  $h_{fb}$  is another hybrid parameter found in the transistor manual. Again the "h" indicates hybrid parameter. The "i" indicates input resistance, while the "b" indicates common base configuration. In its entirety  $h_{fb}$  indicates, "hybrid parameter, input resistance of a common base configuration." Generally  $h_{fb}$  can be found in the data charts supplied by the manufacturer or in a transistor manual.

The nominal range of values for  $h_{fb}$  is from 25 to 100 ohms. Assume that  $h_{fb}$  is equal to 100 ohms in this case, and that  $C_1$  is an a-c short. Assuming this, the input resistance is equal to the parallel values of  $R_E$  and  $h_{fb}$ . If  $R_E$  is equal to, or greater than, 10 times  $h_{fb}$ , then  $R_E$  may be disregarded and the resistance-in,  $R_i$ , is approximately equal to  $h_{fb}$ . In this case  $R_E$  is equal to 10 times  $h_{fb}$ , because  $R_E$  is 1K, while  $h_{fb}$  is equal to 100 ohms. Therefore, disregarding  $R_E$ ,  $R_i$  is approximately equal to 100 ohms.

Common Base Configurations.

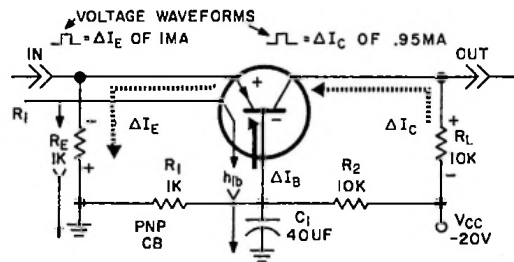

GIVEN:  $\alpha = .95$   
 $h_{ib} = 100 \text{ OHMS}$

$$R_i \approx \frac{R_E \times h_{ib}}{R_E + h_{ib}}$$

$$h_{ib} \approx 25 \text{ TO } 100 \text{ OHMS}$$

$$\text{IF } R_E \leq 10 \times h_{ib} \text{ THEN } R_i \approx h_{ib}$$

$$R_i \approx 100 \text{ OHMS}$$

$$V_{IN} = \Delta I_e \times R_i = 1 \text{ MA} \times 100 \text{ OHMS}$$

$$V_{IN} = 100 \text{ MV}$$

$$V_{OUT} = \Delta I_c \times R_L = .95 \text{ MA} \times 10 \text{ K}$$

$$V_{OUT} = 9.5 \text{ V}$$

Figure 2-21

Now examine figure 2-21 for computations of the voltage-in and the voltage-out. The voltage-in,  $V_{in}$ , is equal to the change in the input current, in this case  $\Delta I_e$ , times  $R_i$ . With a change in the emitter current,  $\Delta I_e$ , equal to one mill and  $R_i$  equal to 100 ohms, the input voltage is equal to 1 mill times 100 ohms, or 100 millivolts. The voltage-out, though, is equal to the change in the collector current,  $\Delta I_c$ , times  $R_L$ . With a 0.95-mill change in the collector current, and a value for  $R_L$  of 10K, this equals 0.95 mill times 10K which equals 9.5 volts.

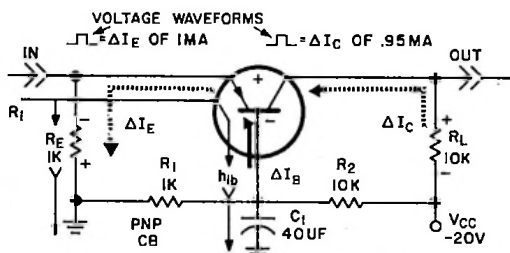

GIVEN:  $\alpha = .95$   
 $h_{ib} = 100 \text{ OHMS}$

$$R_i \approx \frac{R_E \times h_{ib}}{R_E + h_{ib}}$$

$$h_{ib} \approx 25 \text{ TO } 100 \text{ OHMS}$$

$$\text{IF } R_E \leq 10 \times h_{ib} \text{ THEN } R_i \approx h_{ib}$$

$$R_i \approx 100 \text{ OHMS}$$

$$V_{IN} = \Delta I_e \times R_i = 1 \text{ MA} \times 100 \text{ OHMS}$$

$$V_{IN} = 100 \text{ MV}$$

$$V_{OUT} = \Delta I_c \times R_L = .95 \text{ MA} \times 10 \text{ K}$$

$$V_{OUT} = 9.5 \text{ V}$$

$$A_v = \frac{V_{OUT}}{V_{IN}} = \frac{9.5 \text{ V}}{0.1 \text{ V}} = 95$$

$$A_R = \frac{R_o}{R_i} = \frac{10,000}{100} = 100$$

$$A_v = A_R \times \text{ALPHA} = 100 \times .95 = 95$$

Figure 2-22

An examination of figure 2-22 will show that this is a voltage gain,  $A_v$ . The voltage gain of any device is equal to the voltage output divided by the voltage-in. In this case the voltage-out was 9.5 volts, while the voltage-in was 100 millivolts which, when the decimal is moved over, equals 0.1 volt. Therefore, the voltage gain,  $A_v$ , of this circuit is equal to 9.5 divided by 0.1, or  $A_v$  is equal to 95. This may seem odd, as there was actually a current gain of less than 1.

How can there be a voltage gain without a current gain? This is possible because there is a resistance gain,  $A_R$ .  $A_R$  is equal to the resistance-out,  $R_{out}$ , or  $R_{load}$ , divided by the resistance-in,  $R_{in}$ . In this case, this is 10,000 divided by 100 or a resistance gain,  $A_R$ , of 100. An interesting point to remember is that the current gain times the resistance gain always equals the voltage gain. As shown in the computations, the resistance gain,  $A_R$ , which is 100 ohms, times the current gain of 0.95 equals the voltage gain,  $A_v$ , originally computed to be 95.

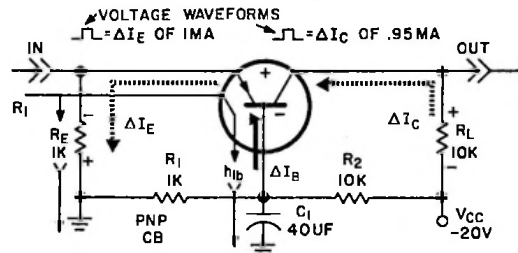

GIVEN:  $\alpha = .95$   
 $h_{ib} = 100 \text{ OHMS}$

$$R_i \approx \frac{R_E \times h_{ib}}{R_E + h_{ib}}$$

$$h_{ib} \approx 25 \text{ TO } 100 \text{ OHMS}$$

$$\text{IF } R_E \leq 10 \times h_{ib} \text{ THEN } R_i \approx h_{ib}$$

$$R_i \approx 100 \text{ OHMS}$$

$$V_{IN} = \Delta I_e \times R_i = 1 \text{ MA} \times 100 \text{ OHMS}$$

$$V_{IN} = 100 \text{ MV}$$

$$V_{OUT} = \Delta I_c \times R_L = .95 \text{ MA} \times 10 \text{ K}$$

$$V_{OUT} = 9.5 \text{ V}$$

$$A_v = \frac{V_{OUT}}{V_{IN}} = \frac{9.5 \text{ V}}{0.1 \text{ V}} = 95$$

$$A_R = \frac{R_o}{R_i} = \frac{10,000}{100} = 100$$

$$A_v = A_R \times \text{ALPHA} = 100 \times .95 = 95$$

$$P_{IN} = \Delta V_{IN} \times \Delta I_e = 0.1 \text{ V} \times 1 \text{ MA}$$

$$P_{IN} = 0.1 \text{ MW}$$

$$P_{OUT} = \Delta V_{OUT} \times \Delta I_c = 9.5 \text{ V} \times .95 \text{ MA}$$

$$P_{OUT} = 9.025 \text{ MW}$$

$$A_p = \frac{P_{OUT}}{P_{IN}} = \frac{8.975}{0.1} = 89.75$$

$$A_p = (\text{ALPHA})^2 \times A_R = .95^2 \times 100$$

$$= .9025 \times 100 = 90.25$$

Figure 2-23

In figure 2-23, the computations for power gain are shown. To obtain power gain, first compute the power-in,  $P_{in}$ . The power-in is equal to the change in the voltage-in,  $\Delta V_{in}$ , times the change in the current-in,  $\Delta I_e$ . The change in the voltage-in of 0.1 volt times the change in the emitter current of 1 mill equals 0.1 milliwatt. Therefore, the power-in equals 0.1 milliwatt. The power-out is equal to the change in the voltage-out,  $\Delta V_{out}$ , times the change in the current-out,  $\Delta I_c$ . This is 9.5 times 0.95 mill which equals 9.025 milliwatts, and the power-out is equal to 9.025 milliwatts. The power gain,  $A_p$ , of this stage is equal to the power-out divided by the power-in. Therefore, 9.025 divided by 0.1 equals the

power gain,  $A_p$ , which equals 90.25. A quicker and easier method of finding this is shown directly below and is similar to the short method of finding voltage gain. Current gain, alpha, squared times resistance gain,  $A_R$ , equals the power gain,  $A_p$ . 0.95 squared equals 0.9025. 0.9025 times the resistance gain of 100 equals a power gain,  $A_p$ , of 90.25. This is the same as that previously found by the long and devious method.

Examine the circuit to see if a phase shift occurs. A positive incoming signal increases the current from the base to emitter,  $I_b$ , and an increase in current from the base to the emitter will increase the current in the collector,  $I_c$ . A greater current flowing from B through the transistor will cause a greater drop across  $R_L$ . Therefore, the collector voltage goes toward ground, which in this case is going in a positive direction, and no phase shift occurs across the emitter-to-collector junction.

The grounded-grid triode circuit also has no phase shift, a current gain of less than one, good voltage gain, and a power gain. It has just been shown that the CB transistor configuration displays these same characteristics, and the grounded-grid tube can be replaced with a common base configuration transistor circuit, and it will perform in exactly the same manner as if it were a tube circuit. This will be true whether it is a PNP or an NPN. The only difference is in the direction of current flow.

**Review.**

Review the material just covered. To begin with, it was found that the transistor is a three-element device as shown in figure 2-24.

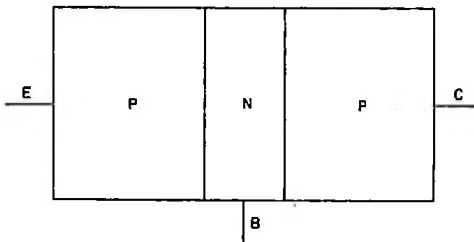

Figure 2-24

These three blocks of material make up two PN junctions, and the transistor has three leads which are labeled "emitter", "base", and "collector".

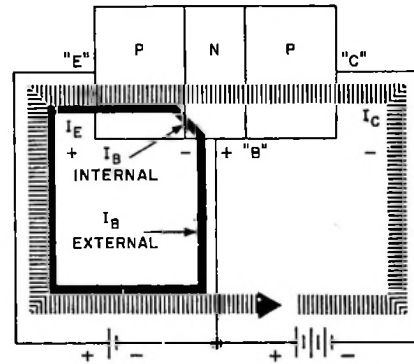

Figure 2-25

The normal bias for a transistor is to have the base emitter forward biased while having the base to collector back biased. The currents flowing in a transistor are labeled " $I_B$ " for base current, " $I_E$ " for emitter current, and " $I_C$ " for collector current.

If a transistor is connected as shown in figure 2-25, the transistor is said to be biased correctly.

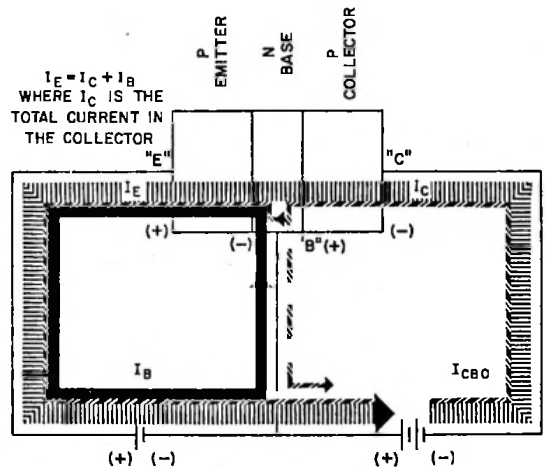

Figure 2-26



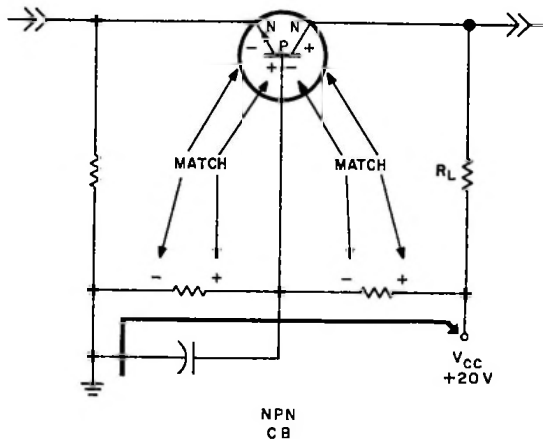

Figure 2-30

An examination of an NPN-type transistor, as in figure 2-30, points out that biasing is the same for NPN or a PNP, and only the direction of current is different. This is also true of all of the currents found in a transistor and the ratios of these different currents.

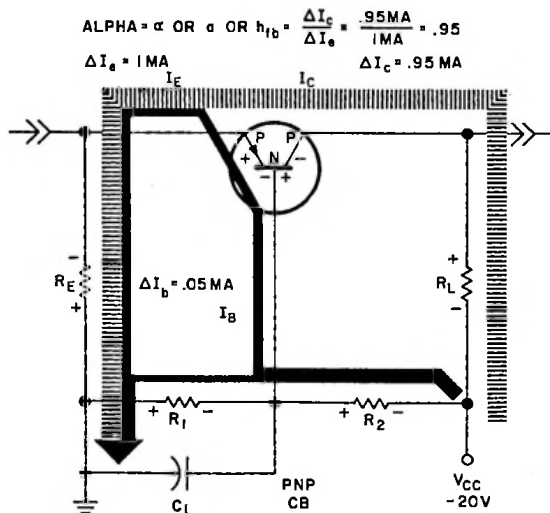

Figure 2-31

The ratio of the change in the collector current to the change in the emitter current is labeled "alpha" as shown in figure 2-31. Alpha is also sometimes found as the Greek letter alpha which looks like one half of an infinity sign or as a small letter "a" or as the hybrid parameter,  $h_{ib}$ . Alpha is equal to  $\Delta I_c$  divided by  $\Delta I_e$ . For the transistor under discussion, alpha equals 0.95. Also with an alpha of 0.95, the

change in  $I_b$  is equal to 0.05 milliampere for a 1-mill change in the emitter current and a 0.95-mill change in the collector current.

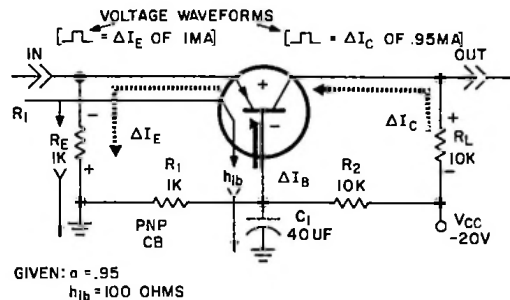
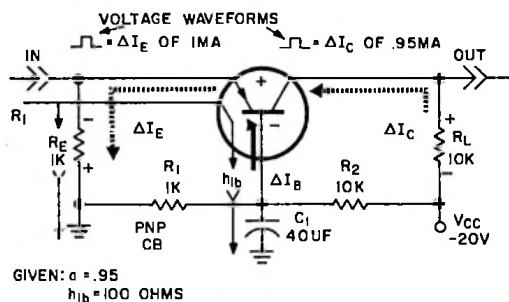

Figure 2-32

Figure 2-32 shows computations for current gain. In this case with change in  $I_e$  of one mill, alpha times  $I_e$  equals a change in the collector current of 0.95 mill. Additionally, the input resistance,  $R_i$ , was found to be equal to the parallel resistance of  $R_E$  and  $h_{ib}$ . If  $R_E$  is equal to or greater than 10 times  $h_{ib}$ , then  $R_i$  is equal to  $h_{ib}$ . Remember,  $h_{ib}$  means, "hybrid parameter, input resistance of a common base configuration."



$$R_i \approx \frac{R_E \times h_{ib}}{R_E + h_{ib}}$$

$$h_{ib} \approx 25 \text{ TO } 100 \text{ OHMS}$$

$$\text{IF } R_E \leq 10 \times h_{ib} \text{ THEN } R_i \approx h_{ib}$$

$$R_i \approx 100 \text{ OHMS}$$

$$V_{IN} = \Delta I_e \times R_i = 1 \text{ MA} \times 100 \text{ OHMS}$$

$$V_{IN} = 100 \text{ MV}$$

$$V_{OUT} = \Delta I_c \times R_L = .95 \text{ MA} \times 10 \text{ K}$$

$$V_{OUT} = 9.5 \text{ V}$$

Figure 2-33

CHAPTER 2  
Transistor Biasing and Configurations

A further examination of the diagram, as shown in figure 2-33, points out that the voltage-in can be computed by multiplying the change in the emitter current,  $\Delta I_e$ , times the resistance-in,  $R_i$ . Also the voltage-out may be computed by multiplying the change in the collector current,  $\Delta I_c$ , times  $R_L$ .

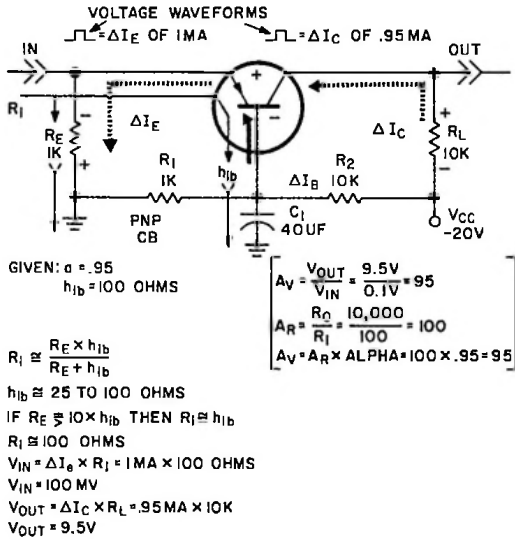
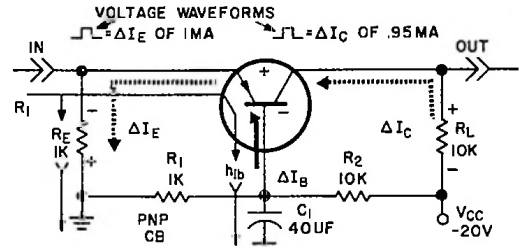

Figure 2-34

The voltage gain can be computed as shown in figure 2-34. The voltage gain,  $A_v$ , is equal to the voltage-out divided by the voltage-in. The common base configuration has a voltage gain even though there is no current gain. This is due to the resistance gain,  $A_R$ . A faster method of computing voltage gain,  $A_v$ , is to multiply the resistance gain,  $A_R$ , times the current gain, alpha.



GIVEN:  $\alpha = .95$   
 $h_{ib} = 100 \text{ OHMS}$

$$A_v = \frac{V_{OUT}}{V_{IN}} = \frac{9.5 \text{ V}}{0.1 \text{ V}} = 95$$

$$A_R = \frac{R_o}{R_i} = \frac{10,000}{100} = 100$$

$$A_v = A_R \times \text{ALPHA} = 100 \times .95 = 95$$

$$P_{IN} = \Delta V_{IN} \times \Delta I_e = 0.1 \text{ V} \times 1 \text{ MA}$$

$$P_{IN} = 0.1 \text{ MW}$$

$$P_{OUT} = \Delta V_{OUT} \times \Delta I_c = 9.5 \text{ V} \times .95 \text{ MA}$$

$$P_{OUT} = 9.025 \text{ MW}$$

$$A_p = \frac{P_{OUT}}{P_{IN}} = \frac{8.975}{0.1} = 89.75$$

$$A_p = (\text{ALPHA})^2 \times A_R = .95^2 \times 100$$

$$= .9025 \times 100 = 90.25$$

Figure 2-35

As shown in figure 2-35 the power gain,  $A_p$ , is equal to the power-out divided by the power-in. Rather than computing the power-in and power-out to find the power gain of a circuit, it is possible to multiply the square of the current gain, alpha, times the resistance gain,  $A_R$ , to obtain the same result. Notice that the common base configuration displays no phase shift from the emitter to the collector, and that a positive input signal causes a positive output signal.

Although the discussion of the common base amplifier is based upon a PNP-type transistor, all of the computations and currents are the same for an NPN, except that the direction of current flow and the polarity of the biases are reversed.

## Section 2 Work Problems

Some of the following problems are arranged so that you may conveniently underscore the correct words, or fill in the blanks, or answer thought questions in your own words. Disregard the value of  $R_1$  for all computations of input resistance.

1. If an NPN transistor is operating normally in a circuit, what polarity of voltage would you expect to find on the collector in respect to the emitter?
  
2. If a transistor is operating normally, the base-\_\_\_\_\_ junction may be considered a forward-biased diode.
  
3. List all of the currents found in a transistor in the order of decreasing magnitude. Start with the highest magnitude.
  - A. \_\_\_\_\_
  - B. \_\_\_\_\_
  - C. \_\_\_\_\_
  - D. \_\_\_\_\_
  
4. Internal  $I_B$  is equal to \_\_\_\_\_.
  
5.  $I_{CBO}$  (increases or decreases) as temperature decreases.
  
6.  $I_E$  is equal to \_\_\_\_\_.
  
7. If  $I_B$  decreases,  $I_C$  (increases or decreases).
  
8. The CB configuration compares to the \_\_\_\_\_ triode circuit.
  
9. If the voltage on the emitter of a transistor is negative in respect to the base and the transistor is conducting, then the transistor must be (a PNP or an NPN).
  
10. For all of the following parts, refer to the diagram in figure 2-35 and use the following values. Disregard the value of  $R_E$  in all computations.

Alpha = 0.98  
 $h_{ib} = 50$  ohms  
 $R_1 = 1K$   
 $R_E = 1K$

$R_2 = 10K$   
 $R_L = 5K$   
 $\Delta I_e = 0.5$  ma

- A. Find  $\Delta I_C$
  
- B. Find  $R_i$
  
- C. Find  $A_R$
  
- D. Find  $A_v$
  
- E. Find  $A_p$

When you have read and studied all of the first half of chapter 2, and answered all the preceding questions to the best of your ability, you are ready to proceed to the next tape-slide presentation where the answers to the above problems will be given and explained.



**Introduction.**

Section 3 of the tape-slide presentation consists of the second half of chapter 2, the chapter on biasing and the three basic transistor configurations. During this portion, the common emitter and collector configurations will be discussed in detail. Computations will be shown for power gain, voltage gain, current gain, resistance gain, and phase shift.

**Common Emitter Configuration.**

The tube circuit most commercially used is known as the grounded cathode.

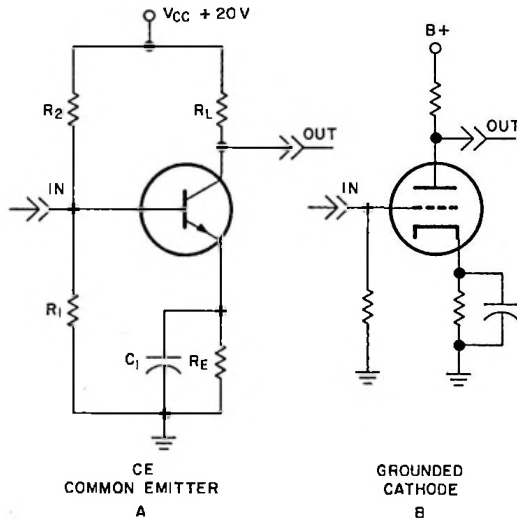

Figure 2-36

Examine a circuit similar to this that is transistorized. In figure 2-36, a transistor is shown connected in what is called a common emitter, CE, configuration. The common emitter amplifier compares exactly with the grounded cathode triode tube. It obtains its name, common emitter, because the emitter is common to the input and the output signals. The feedback resistor,  $R_E$ , compensates for temperature changes at the collector-base junction.  $R_E$  will nullify variations in the d-c operating point caused by these temperature variations. Because  $C_1$  is large enough to act as an a-c short, the effect of both  $R_E$  and  $C_1$  may be disregarded when calculating gain.

Examine figure 2-37 to see if the biasing is correct. Applying the rules of correct biasing, first determine the type of transistor. The transistor is an NPN indicated by the fact that the emitter arrow points away from the base. Next mark the letters 'N-P-N'

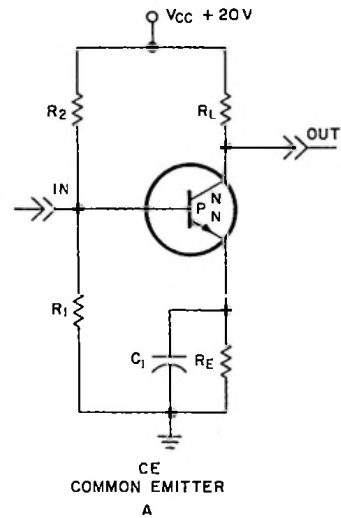

Figure 2-37

on the back side of the transistor diagram as is shown in figure 2-37.

Then, as in figure 2-38, starting at the emitter and using the polarity of the emitter, in this case it being 'N' type ('N' for negative), mark in the polarities of the bias. Going in series from the emitter toward the collector, on the front of the transistor diagram, the polarities required across this transistor to bias it correctly are negative, positive, negative, positive.

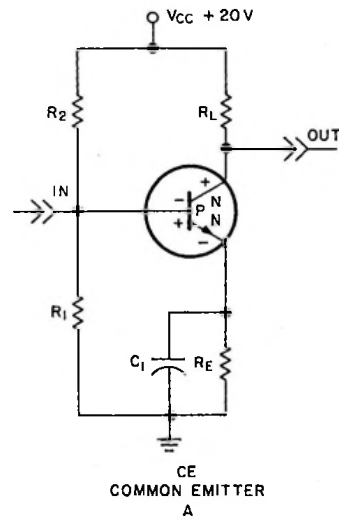

Figure 2-38

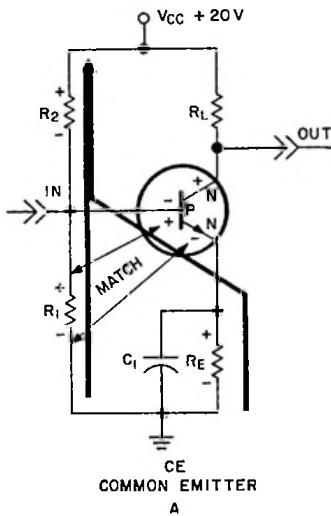

Figure 2-39

An examination of figure 2-39 will show that this polarity is available for the base-emitter junction. The current flow in the external circuit is from ground through  $R_1$ , through  $R_2$ , developing a voltage from bottom to top which will be negative to positive across  $R_1$  and negative to positive across  $R_2$ , as is shown. The junction of  $R_1$  and  $R_2$  is shown connected to the base of the transistor, while the bottom of  $R_1$  is connected to ground. Therefore, the base is positive in respect to ground and the base-emitter junction is forward biased.

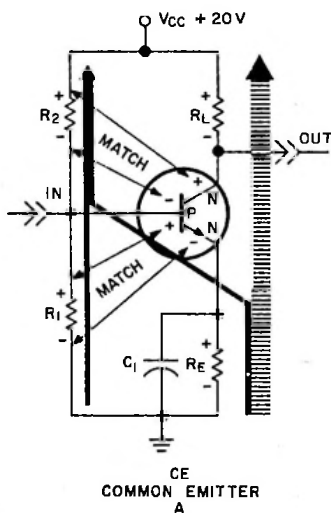

Figure 2-40

Observe the base-collector junction bias as shown in figure 2-40. The base-collector junction plus  $R_L$  is in parallel with  $R_2$ , and the polarity of the voltage across  $R_2$  appears across the base-collector junction as shown.

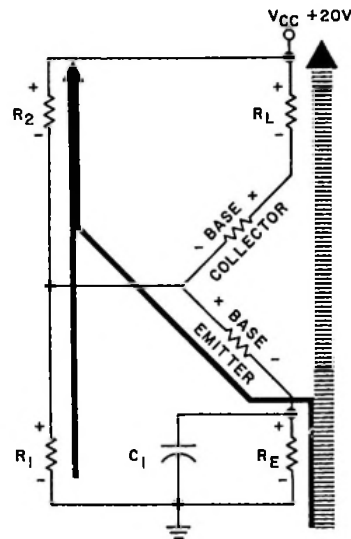

Figure 2-41

An examination of figure 2-41 will show that these polarities must exist across the junctions with this biasing arrangement. The transistor is shown here as two resistances. One resistance represents the base-emitter junction and is a low resistance. The other resistance representing the base-to-collector junction is a high resistance. Since neither the base-to-collector junction or the base-to-emitter junction ever exhibit an infinite impedance, the transistor may be considered as two resistances representing base-emitter junction and the base-collector junction for biasing purposes. The current flow must be from the emitter to the base, negative to positive, respectively, and from the base to the collector, negative to positive, respectively, and continuing negative to positive through  $R_L$  to  $B+$ .

The transistor will be correctly biased, as shown in figure 2-42, whenever two resistances are connected between  $B+$  and ground, with the junction of the two connected to the base if no resistor is in shunt with the transistor from the emitter to the top or bottom of  $R_L$ .

Let us examine the common emitter, CE, configuration for current gain, input resistance, resistance gain, voltage-in and voltage-out, voltage gain, power gain, and phase shift.

Figure 2-43 shows the computations that can be used to find the current gain,  $A_i$ , in a common emitter configuration.

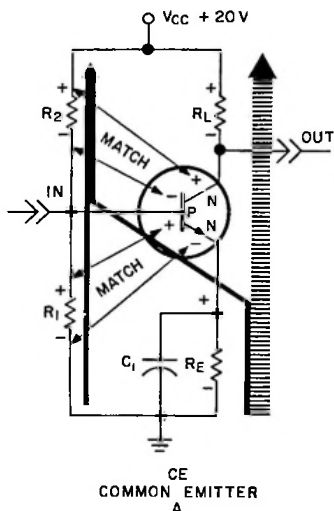

Figure 2-42

Recall that the symbol for alpha was used to represent the ratio of delta  $I_c$  divided by delta  $I_e$  which gave us the forward current gain in a common base configuration. In a corresponding manner, the symbol beta is used to represent the ratio of delta  $I_c$ , the change in collector current, divided by delta  $I_b$ , the change in base current. This ratio gives us the forward current gain in a common emitter configuration:

Whereas alpha values are always less than 1, beta values will always be larger than 1.

Since the common emitter configuration is encountered more frequently than the other two configurations, beta is found more often than alpha in transistor data specifications. It generally appears as a hybrid

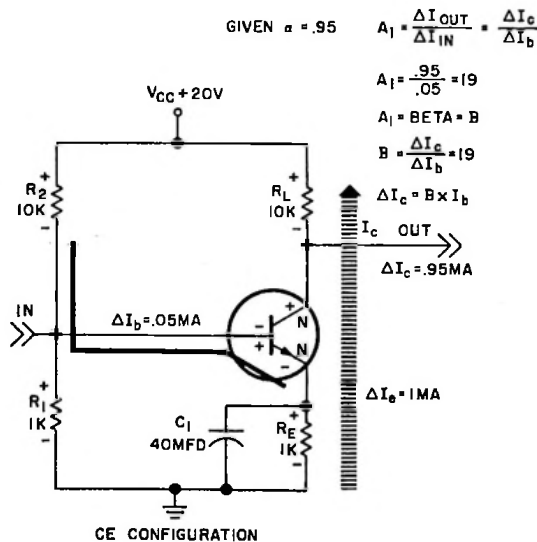

Figure 2-43

GIVEN  $\alpha = .95$

$$A_1 = \frac{\Delta I_{OUT}}{\Delta I_{IN}} = \frac{\Delta I_c}{\Delta I_b}$$

$$A_1 = \frac{.95}{.05} = 19$$

$$A_1 = \text{BETA} = B$$

$$B = \frac{\Delta I_c}{\Delta I_b} = 19$$

$$\Delta I_c = B \times I_b$$

$$\Delta I_c = .95 \text{ MA}$$

$$\Delta I_e = 1 \text{ MA}$$

parameter,  $h_{fe}$ , which means "forward current transfer ratio of a transistor in a common emitter configuration." Beta also can be computed directly from the characteristic curves for the transistor.

Notice neither alpha nor beta, the ratios of currents from input to output, in a common base or common emitter circuit consider the value of  $R_L$  in their equations. So therefore, an output off the collector is called a constant current source. This means that no matter what the value of  $R_L$ , the collector current will be constant for a constant base current. The base current,  $I_b$ , is not dependent upon  $R_L$ .

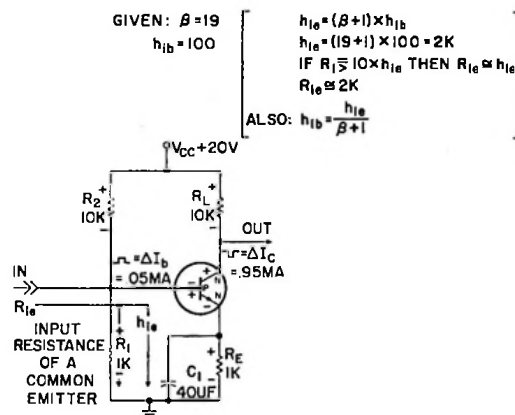

GIVEN:  $\beta = 19$   
 $h_{ib} = 100$

$$h_{ie} = (\beta + 1) \times h_{ib}$$

$$h_{ie} = (19 + 1) \times 100 = 2K$$

IF  $R_1 \geq 10 \times h_{ie}$  THEN  $R_{ie} \approx h_{ie}$   
 $R_{ie} \approx 2K$

ALSO:  $h_{ib} = \frac{h_{ie}}{\beta + 1}$

Figure 2-44

Recall that when we figured the input resistance,  $R_i$ , of the common base configuration we found that  $R_i$  is equal to  $h_{ib}$ , the base-emitter resistance, when  $R_E$  is equal to, or greater than, 10 times  $h_{ib}$ .

In the common emitter configuration, as shown in figure 2-44, the input resistance of the circuit,  $R_{ie}$ , is the parallel resistance of  $R_1$  and  $h_{ie}$ . The hybrid parameter,  $h_{ie}$ , is the input resistance of a common emitter circuit. When  $h_{ib}$  is given,  $h_{ie}$  can be found by multiplying beta plus 1 times  $h_{ib}$ . Sometimes the transistor manual will give  $h_{ie}$  rather than  $h_{ib}$ , then  $h_{ib}$  can be found by dividing  $h_{ie}$  by beta plus 1.

As shown in figure 2-44,  $h_{ie}$  is equal to 19 plus 1 times 100 which equals 2K. In computing the value of  $R_{ie}$ , if  $R_1$  is equal to or greater than 10 times  $h_{ie}$ , then  $R_{ie}$  is approximately equal to  $h_{ie}$ . This is not true, in this case, as  $R_1$  is equal to one half of  $h_{ie}$ , and the parallel resistance of these two values must be computed to find the actual input resistance as seen by a circuit driving this stage. Since we are not interested in the losses incurred between interstage coupling, and are only interested in the impedance that delta  $I_b$  sees, we will assume that for purposes of this discussion  $R_{ie}$  is approximately equal to  $h_{ie}$  or 2K. This is the impedance delta  $I_b$  would see.

CHAPTER 2  
Transistor Biasing and Configurations

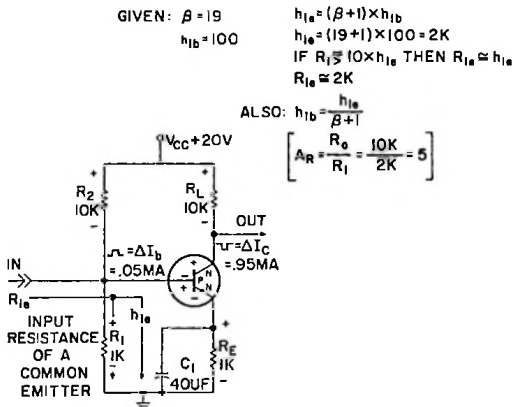

Figure 2-45

Figure 2-45, shows the computations for the resistance gain,  $A_R$ , of a common emitter amplifier.  $A_R$  is equal to the output resistance,  $R_o$ , divided by the input impedance,  $R_i$ .  $R_o$  is equal to 10K, while  $R_i$  is equal to 2K. Therefore,  $A_R$  is equal to 5. Notice that this value is much smaller than that found for the common base configuration. This is due to the higher input impedance of a common emitter amplifier.

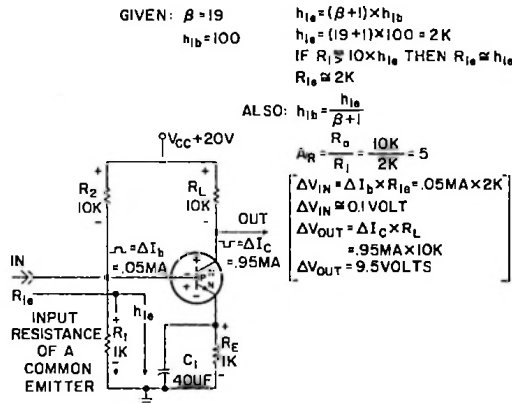

Figure 2-46

The voltages in and out can be computed as shown in figure 2-46. The change in the voltage-in equals

$\Delta I_b$  times  $R_{ie}$ .  $\Delta I_b$  is equal to 0.05 mill, and  $R_{ie}$  is found to be equal to 2K ohms. Therefore, the change in the voltage input is equal to 0.05 mill times 2K, or 0.1 volt. The change in the voltage-out can be computed by multiplying  $\Delta I_c$  times  $R_L$ .  $\Delta I_c$  equals 0.95 mill and  $R_L$  equals 10K ohms. Therefore, the change in the voltage-out is equal to 0.95 mill times 10K ohms, or 9.5 volts.

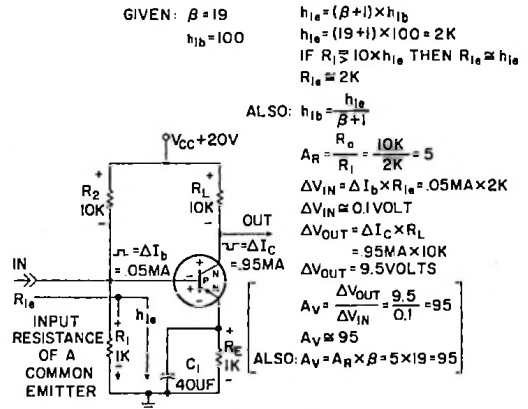

Figure 2-47

This represents a voltage gain,  $A_V$ , as shown in figure 2-47.  $A_V$  is equal to the change in the voltage-out divided by the change in the voltage-in. The change in the voltage-out was equal to 9.5 volts while the change in the voltage-in was equal to 0.1 volt. Therefore, the voltage gain,  $A_V$ , is equal to 9.5 over 0.1 which equals a voltage gain of approximately 95. Also as was found in the case of a common base amplifier, the voltage gain,  $A_V$ , can be computed by multiplying the resistance gain,  $A_R$ , times beta. This means that 5 times 19 should equal the voltage gain obtained above, and it does. Notice that the voltage gain obtained in this case is equal to the voltage gain obtained in the common base configuration. Actually the gain of this configuration should be slightly smaller by about one or two, since the common base configuration always has a slightly higher voltage gain. This error is due to the inexact equations used, and is close enough in actual circuit work.

Now examine figure 2-48 for computations of the power gain. The power-in is approximately equal

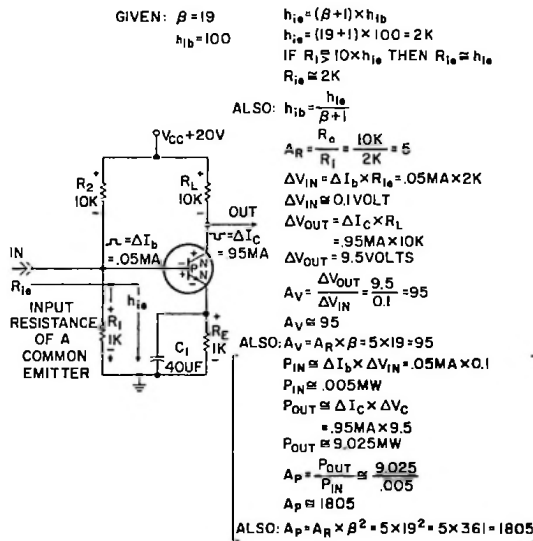

Figure 2-48

to the change in the base current times the change in the voltage-in. The change in the base current is 0.05 mill, and from previous computations it was found that the voltage-in is equal to 0.1 volt. 0.05 mill times 0.1 volt equals 0.005 milliwatt giving power-in as approximately equal to 0.005 milliwatt. The power-out is approximately equal to the change in the collector current times the change in the collector voltage. The change in the collector current was 0.95 mill, and the change in the collector voltage for this current change was found to be 9.5 volts. 0.95 mill times 9.5 volts equals a power-out of 9.025 milliwatts. The power gain,  $A_p$ , is equal to the power-out over the power-in. Power-out is found to be 9.025 milliwatts and the power-in was 0.005 milliwatt. Power gain is therefore equal to 9.025 divided by 0.005. This equals a power gain of 1805.

Also the power gain,  $A_p$ , may be found by multiplying the resistance gain,  $A_R$ , times beta squared. The resistance gain is 5 while beta is 19. 19 squared is equal to 361. Therefore, 5 times 361 equals the power gain of 1805.

The common emitter amplifier does have a phase shift between the base and the collector as shown in figure 2-49. Assume that a positive signal is inserted to cause the 0.05-mill change in the base current, delta  $I_b$ . The positive incoming signal increases the base current by delta  $I_b$ , because it comes in on "P" type material. A positive on "P" type material increases the current. A positive on "N" type material always increases the conduction of the device. The increase in the base current by delta  $I_b$  causes an increase in the collector current by delta  $I_c$ .

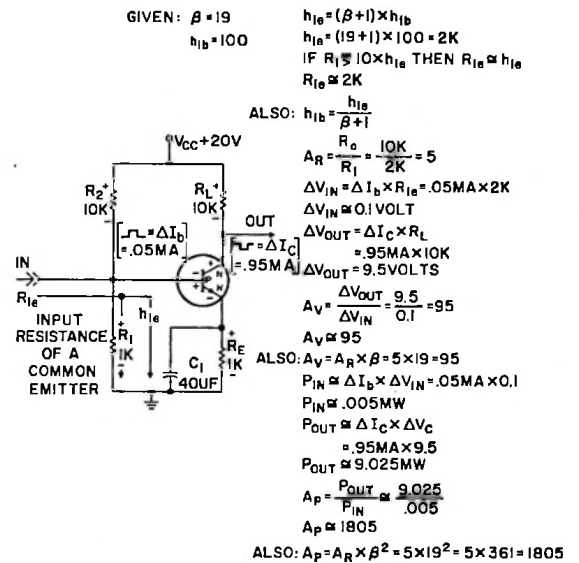

Figure 2-49

The increase in  $I_c$  will cause a greater voltage drop across  $R_L$ , and the collector of the transistor will go more negative. If the collector goes more negative, there is a 180-degree phase shift between the base and the collector because a positive input causes a negative output. This is also true in tubes where the signal on the plate is 180 degrees out of phase with the signal on the grid. All transistors, whether PNP or NPN, will have a phase shift of 180 degrees from the base to the collector.

Each of the parameters that have been discussed in the common emitter configuration compare with the parameters that would be found in the grounded cathode tube circuit. In other words, there is a phase shift of 180 degrees from input to output, a voltage gain, a power gain, a current gain, and a medium input impedance to a high output impedance.

### Common Collector Configuration.

So far the discussion has covered the grounded base and grounded emitter configurations. The grounded collector configuration is shown in figure 2-50. This is called the common collector configuration, and it compares to the grounded plate tube configuration, better known as the cathode follower. The common collector configuration of the transistor also is known as an emitter follower. Either name is correct. The common collector configuration obtains its name because the collector is common to both the input and the output.

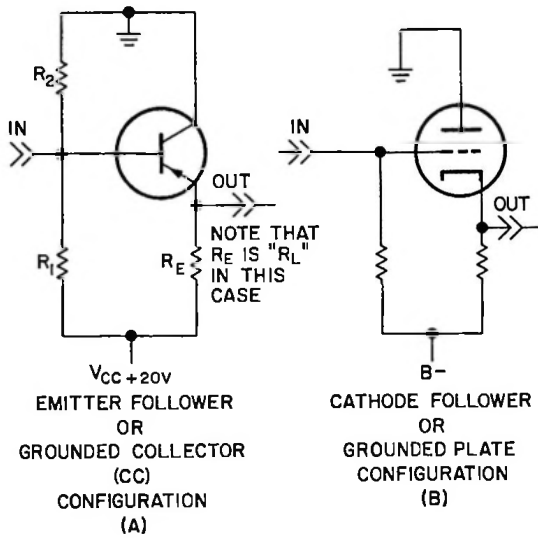

Figure 2-50

Before examining the common collector configuration for circuit-operating parameters, examine figure 2-51 for the correct biasing. First, determine the type of transistor. The arrow is pointing toward the base, so therefore, this is a PNP-type transistor. Write these letters on the back side of the transistor diagram.

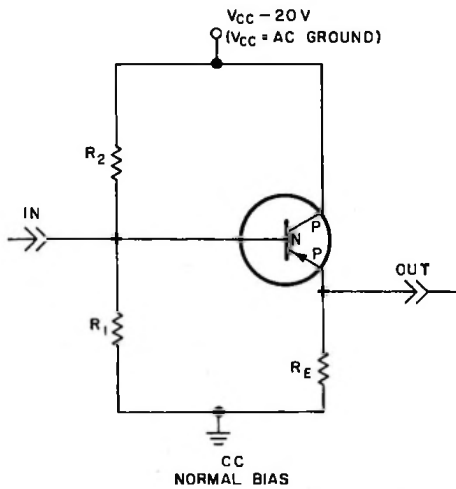

Figure 2-51

Then, starting at the emitter, as shown in figure 2-52, apply the same polarity that the material indicates ("P" for positive), and going toward the collector go

positive, negative, positive, negative in series. This is the polarity of the bias necessary for correct biasing of the transistor.

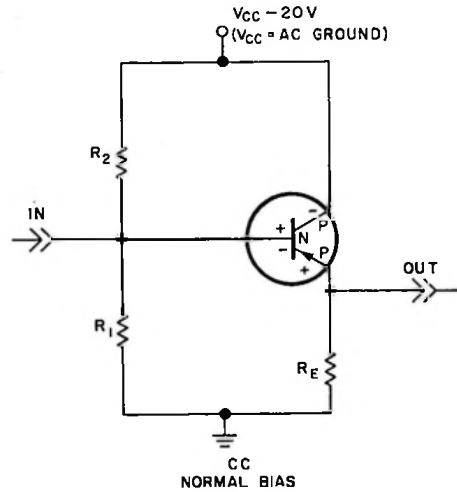

Figure 2-52

The next step is to examine the biasing arrangement of figure 2-53 to see if the correct polarity is available for base-emitter bias. Current flow in this circuit is from B- to ground, down through  $R_2$ , down through  $R_1$ . This develops a negative to positive from top to bottom on each of these resistors, applying a negative at the top of  $R_1$  to a positive at the bottom

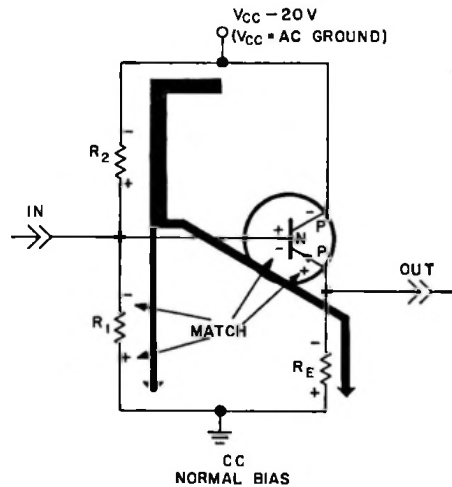

Figure 2-53

of  $R_1$ .  $R_1$  is in parallel with the base-emitter resistance plus  $R_E$ . This must apply a forward bias to the base-emitter junction. If there is no current in the emitter, then there will be a forward-biased condition across the base-emitter. This is because  $R_E$  will have no voltage drop across it. As soon as a forward-bias condition occurs, there will be some voltage dropped across  $R_E$ , but since the current in the emitter is dependent upon the current in the base, the voltage drop across  $R_E$  is negative at the top, to positive at the bottom, and can never be more negative at the top than the voltage at the junction of  $R_1$  and  $R_2$ .

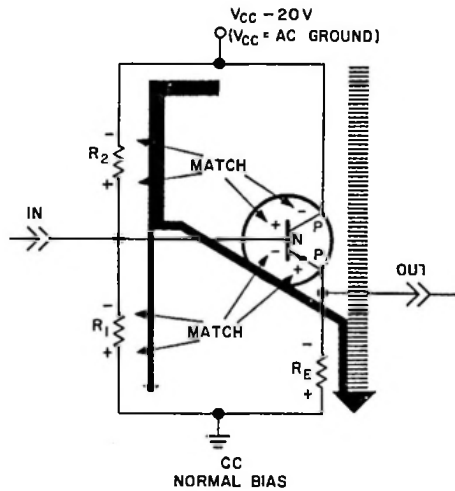

Figure 2-54

Figure 2-54 indicates that the correct polarity of bias is across the base collector junction also. This must be true, because the polarity across  $R_2$  matches the polarity desired across the transistor.

The biasing arrangement for the common base, the common emitter, and the common collector configuration has been shown the same in every case, and in every case the transistor is found to be forward biased.

If only one supply is used, this biasing arrangement, will always cause the transistor to be forward biased.

The only method that may be used to bias off a transistor with one supply is to bypass the transistor from collector to emitter with another resistor as shown in figure 2-55. The biasing arrangement of figure 2-55 consists of two resistance voltage dividers. One voltage divider consists of  $R_2$  and  $R_1$ ,

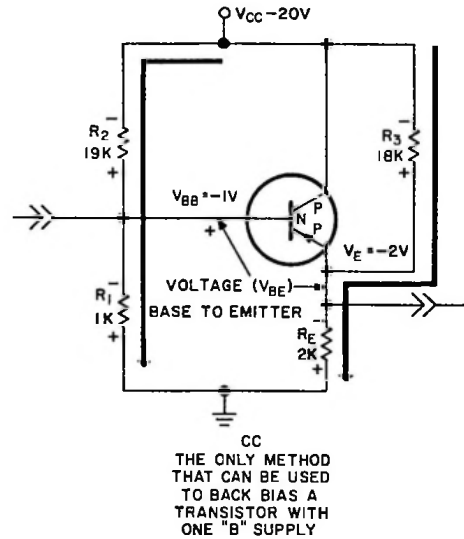

Figure 2-55

while the other consists of  $R_3$  and  $R_E$ . Because of the value picked for  $R_1$  and  $R_2$ , the voltage at the junction of  $R_1$  and  $R_2$  which is called  $V_{BB}$ , meaning voltage of the base supply, is equal to a minus 1 volt.

Due to the values picked for  $R_3$  and  $R_E$ , the voltage at the junction of  $R_3$  and  $R_E$ ,  $V_{EE}$ , equals minus 2 volts. This places a negative 2 volts on the emitter and a negative 1 volt on the base of the transistor. This places a negative to positive from the emitter to the base, respectively, and would back bias the transistor by 1 volt. The voltage across the base-emitter junction of a transistor is called  $V_{BE}$ , meaning voltage from the base to the emitter.

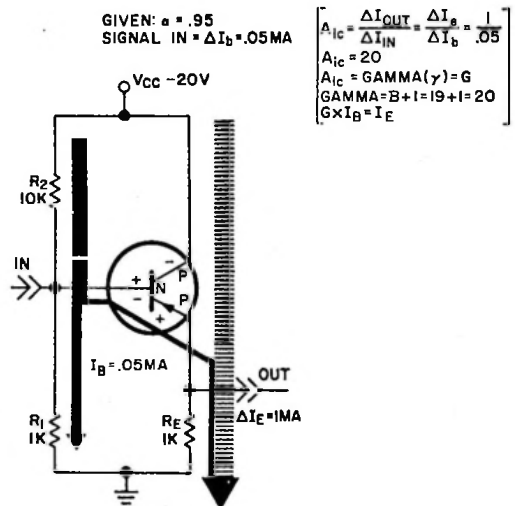

Figure 2-56

CHAPTER 2

Transistor Biasing and Configurations

Computations for current gain in a common collector configuration are shown in figure 2-56. If using the same type of transistor as in the previous configuration, alpha will be equal to 0.95. Assume a signal input that will cause a change in the base current,  $\Delta I_b$ , of 0.05 milliamperere. The current gain of the common collector,  $A_{iC}$ , is equal to the change in the current-out divided by the change in the current-in. This means that  $A_{iC}$  is equal to  $\Delta I_e$  divided by  $\Delta I_b$ . With a change of 0.05 milliamperere in  $I_b$ , the emitter current,  $I_e$ , will change 1 milliamperere. 0.05 into 1 equals a current gain,  $A_{iC}$ , of 20.  $A_{iC}$  is called gamma. The Greek letter for gamma is shown but is seldom used, instead the letter "G" is used. Gamma also is equal to beta plus 1. For an alpha of 0.95 it is found that beta is equal to 19, so therefore, 19 plus 1 equals gamma, which equals 20. Gamma times  $I_B$  equals  $I_E$ .

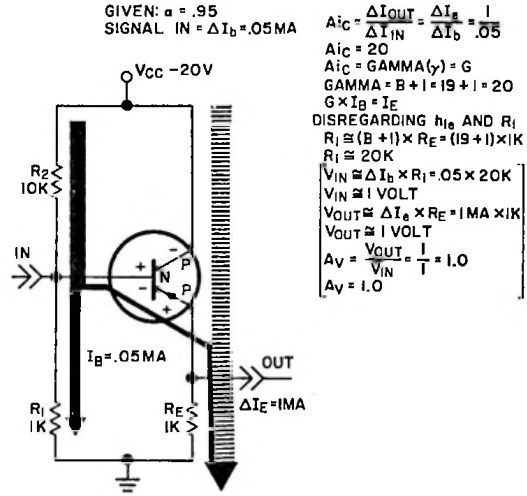

Figure 2-58

voltage-in is equal to  $\Delta I_b$  times  $R_{iC}$ . This equals 0.05 times 20K, and is approximately equal to 1 volt. The voltage-out is approximately equal to  $\Delta I_e$  times  $R_E$ . Therefore 1 mill times 1K equals 1 volt. The voltage gain,  $A_v$ , equals the voltage-out divided by the voltage-in. This could be 1 divided by 1 for a voltage gain,  $A_v$ , of 1. In reality the voltage gain of a common collector configuration is always slightly less than one. The error, in this case, results from disregarding the value of  $h_{ie}$ .

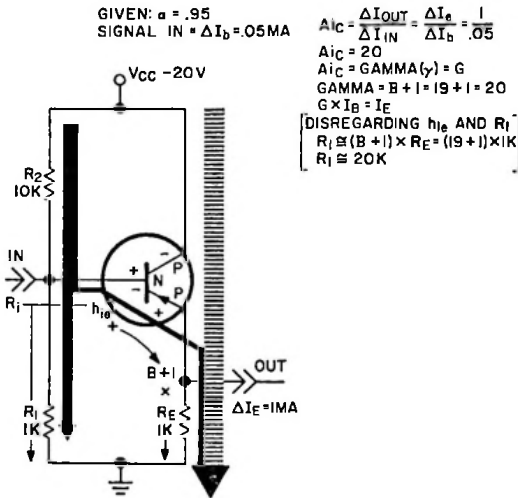

Figure 2-57

Now examine figure 2-57 for computations of the input resistance of the common collector configuration.

The input resistance of a common collector configuration consists of the parallel resistance of  $R_1$  in parallel with  $h_{ie}$  plus beta plus 1 times  $R_E$ . Although a good portion of the input signal from another stage would be lost through  $R_1$ , we are only interested in the position of the signal which reaches the base of the transistor, so therefore,  $R_1$  will be disregarded. In the common collector configuration,  $h_{ie}$  may be disregarded in computations of the input resistance without causing a large error in the computations. Disregarding  $h_{ie}$  and  $R_1$ ,  $R_{iC}$  is then approximately equal to beta plus 1 times  $R_E$ . This is equal to 19 plus 1 times 1K, or  $R_{iC}$  is approximately equal to 20K ohms.

In figure 2-58, computations for the voltage gain of a common collector configuration are shown. The

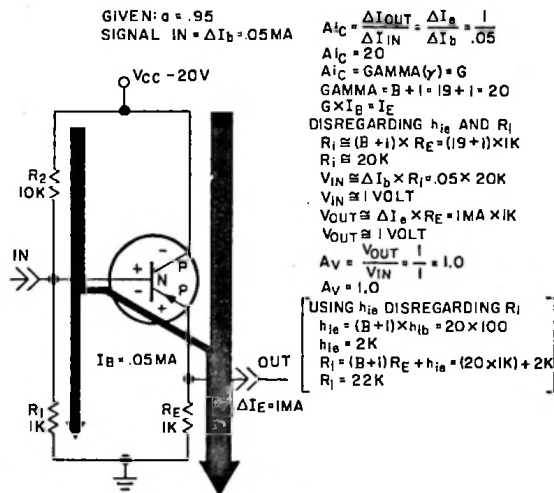

Figure 2-59



Figure 2-59 shows the computations for  $R_{iC}$  using  $h_{ie}$ .  $h_{ie}$  is equal to beta plus 1 times  $h_{ib}$ .  $h_{ib}$  is given as 100 ohms. Therefore,  $h_{ie}$  is equal to 20 times 100, or 2K.  $R_{iC}$  is equal to beta plus 1 times  $R_E$  plus  $h_{ie}$ . Therefore,  $R_{iC}$  is equal to the quantity 20 times 1K plus 2K, or 22K. Notice that this is 2K ohms greater than that obtained when  $h_{ie}$  was disregarded.

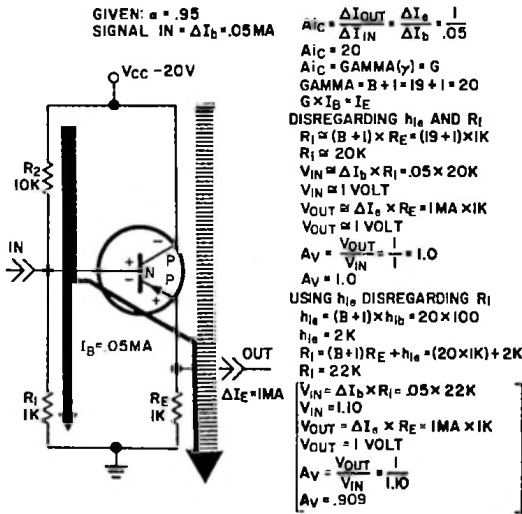

Figure 2-60

Using this value for  $R_{iC}$ , figure 2-60 shows the computations for the voltage gain. The voltage-in is still equal to delta  $I_b$  times  $R_{iC}$ . In this case though  $R_{iC}$  is equal to 22K ohms, and the voltage-in is then equal to 0.05 times 22K. The voltage-in is now equal to 1.1 volt. The voltage-out is still equal to delta  $I_c$  times  $R_C$ . Either delta  $I_c$  or  $R_C$  changes from the previous computations, so the voltage-out is still equal to 1 volt. The voltage gain,  $A_V$ , can then be computed as the voltage-out divided by the voltage-in. The voltage-out is 1 volt, while the voltage-in was 1.1 volt. This results in a voltage gain,  $A_V$ , of 0.909. Note the voltage gain of a common collector configuration is less than 1, but, in this case, the error involved by disregarding  $h_{ie}$  is negligible and results in an error of only 10 percent.

As shown in figure 2-61, the voltage gain may be computed by first finding the resistance gain.

The resistance gain of any circuit is equal to the output resistance,  $R_O$ , divided by the input resistance,  $R_i$ . The actual input resistance, as found in figure 2-60, is 22K. The output resistance, on the other hand, is equal to  $R_E$ , which has a value of 1K. 1K divided by 22K equals 0.045. The voltage gain,  $A_V$ , is equal to gamma times  $A_R$ . Gamma is equal to beta plus 1; therefore gamma is equal to 20.

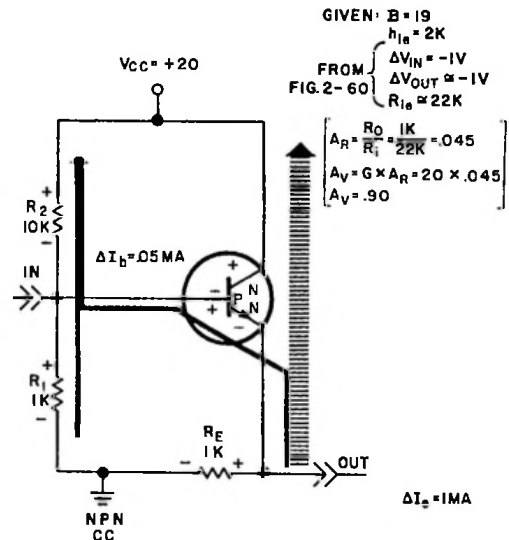

Figure 2-61

20 times 0.045 approximately equals the voltage gain,  $A_V$ , of 0.909 previously obtained in figure 2-60.

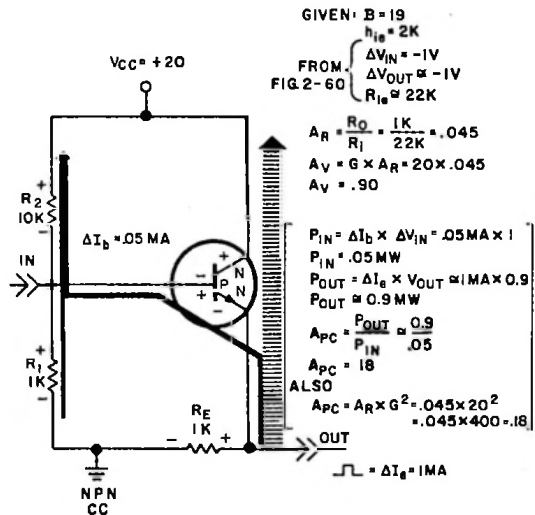

Figure 2-62

Figure 2-62 shows the computations for power gain. The power-in is equal to the change in the base current, delta  $I_b$ , times the change in the voltage-in. Delta  $I_b$  is equal to 0.05 milliamperes, while the voltage-in was found to be equal to 1 volt. 0.05 milliamperes times 1 volt equals a power-in of 0.05 milliwatt. The power-out, on the other hand, is equal to delta  $I_c$  times the voltage-out. The power-out therefore is equal to 1 milliamperes times 0.9 volt, or the power-out is equal to 0.9 milliwatt.

CHAPTER 2  
Transistor Biasing and Configurations

The power gain of a common collector,  $A_{pc}$ , can then be computed by dividing the power-out by the power-in. The power gain is then equal to 0.9 divided by 0.05. This common collector configuration, therefore, has a power gain of 18. The power gain,  $A_{pc}$ , also can be computed by multiplying the resistance gain,  $A_R$ , times gamma squared. Therefore, the power gain is equal to 0.045 times 20 squared, or 0.045 times 400 which equals 18, the power gain obtained previously.

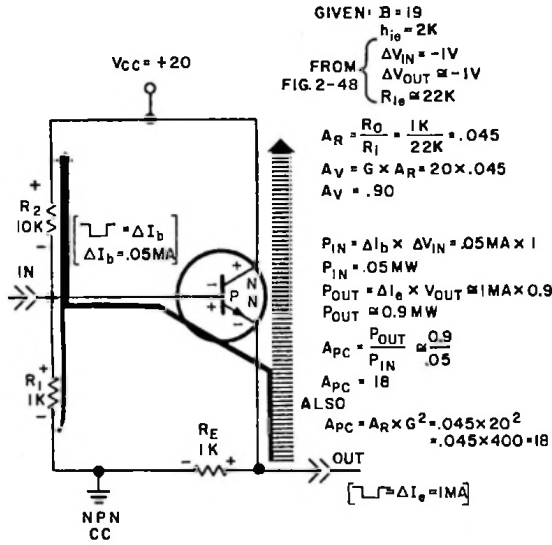

Figure 2-63

Figure 2-63 points out that there is no phase shift from the base to the emitter as in a common emitter configuration.

Due to the following action of the emitter, if a negative is inserted on the base, the voltage on the emitter will go in a negative direction also. This can be explained by the fact that a negative on the base causes a decrease in current. If a negative signal is inserted on "P" type material, it will always cause a decrease in current. A decrease in current through the base emitter causes a decrease in current from the collector to the emitter and a decreasing current through  $R_E$  from bottom to top. This causes a less negative to positive voltage drop across  $R_E$ , and the voltage across  $R_E$  goes in a negative direction. Therefore, there is no phase shift in the output.

There is no phase shift from the base to the emitter because the base to the emitter is nothing more than a forward-biased diode. Figure 2-64 also shows why the voltage gain is always very nearly 1. The base-to-emitter voltage for germanium, Ge, and silicon, Si, is shown plotted at the bottom of the graph. Emitter current for each of the different base voltages is plotted along the left-hand side of the graph. It

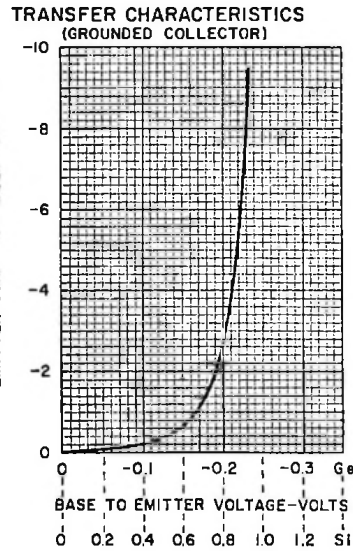

Figure 2-64

takes approximately 0.15 volt for germanium and 0.6 volt for silicon before any appreciable amount of emitter current will flow. After this point the current will increase by a large amount for a very small change in the base in the emitter voltage. A general statement is sometimes made that the maximum expected voltage drop across the base emitter of a transistor will be 0.25 volt for germanium and 1 volt for silicon. Figure 2-64 bears this out, as the current will be somewhere off the top of the graph if the voltage from base to emitter is equal to 0.25 volt for germanium or 1 volt for silicon.

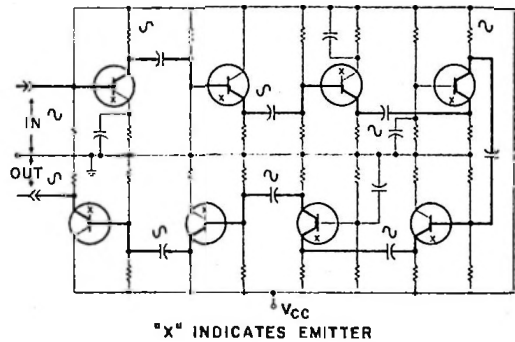

Figure 2-65

You have examined the three basic configurations: the common base, CB, configuration; the common emitter, CE, configuration; and the common collector, CC, configuration. Of the three configurations, it was found that only the common emitter had a phase shift, while the common collector and the common base had no phase shift. Therefore, a rule that could be formulated is, "a phase shift only occurs if the signal is going from the base to the collector, and at no other time is there a phase shift."

Remember that this is not dependent upon the type of transistor. It is not necessary to know whether the base current or the collector current is increasing or decreasing to know whether a phase shift occurs in the signal. If a number of transistors are connected in any order, as in figure 2-65, and the polarity of the input signal is known, it is possible to determine the phase of the output only by knowing which lead is the emitter. In this circuit the emitters are marked with an X, and no indication is made of the type of transistor or the polarity of the supplies. The biasing must be correct, otherwise the circuit would not normally work and no circuit is designed not to work. It still can be said that when a signal is transferred from the base to the collector of any transistor stage, there is a phase shift, and when a signal is transferred from the emitter to the collector or the base to the emitter of any stage there is no phase shift. Therefore, in a straight signal flow type of circuit work, when the interest lies only in knowing the polarity of the signal-out, it is not necessary to know the type of transistor, but only the general rule that when a signal is transferred from the base to the collector, there is a 180-degree phase shift and only then.

Figure 2-66, lists the ratios alpha, beta, gamma, and the conversions from one to the other. It was found

that alpha is a ratio of a change in  $I_c$  to a change in  $I_e$  and is always less than one, that beta is a ratio of a change in  $I_c$  to the change in  $I_b$  and is always greater than 1; and that gamma is a ratio of a change in  $I_e$  to a change in  $I_b$  and is always greater than 1.

WHEN	$\alpha$ IS KNOWN	$\beta$ IS KNOWN	$\gamma$ IS KNOWN
TO FIND			
ALPHA $\alpha$ $A = \frac{\Delta I_C}{\Delta I_E}$	-	$\frac{\beta}{1+\beta}$	$\frac{\gamma-1}{\gamma}$
BETA $\beta$ $B = \frac{\Delta I_C}{\Delta I_B}$	$\frac{\alpha}{1-\alpha}$	+	$\gamma-1$
GAMMA $\gamma$ $G = \frac{\Delta I_E}{\Delta I_B}$	$\frac{1}{1-\alpha}$	$\beta+1$	+

Figure 2-67

Sometimes it becomes necessary to find alpha when only beta is given. In this case, as shown in figure 2-67, the equation, alpha is equal to beta divided by 1 plus beta, must be used to convert beta to alpha. The transistor that was used in the discussion had a beta of 19. Therefore, alpha is equal to 19 divided by 1 plus 19, or 19 divided by 20. 20 divided into 19 is equal to 0.95.

WHEN	$\alpha$ IS KNOWN	$\beta$ IS KNOWN	$\gamma$ IS KNOWN
TO FIND			
ALPHA $\alpha$ $A = \frac{\Delta I_C}{\Delta I_E}$	-	$\frac{\beta}{1+\beta}$	$\frac{\gamma-1}{\gamma}$
BETA $\beta$ $B = \frac{\Delta I_C}{\Delta I_B}$	$\frac{\alpha}{1-\alpha}$	+	$\gamma-1$
GAMMA $\gamma$ $G = \frac{\Delta I_E}{\Delta I_B}$	$\frac{1}{1-\alpha}$	$\beta+1$	+

Figure 2-66

WHEN	$\alpha$ IS KNOWN	$\beta$ IS KNOWN	$\gamma$ IS KNOWN
TO FIND			
ALPHA $\alpha$ $A = \frac{\Delta I_C}{\Delta I_E}$	-	$\frac{\beta}{1+\beta}$	$\frac{\gamma-1}{\gamma}$
BETA $\beta$ $B = \frac{\Delta I_C}{\Delta I_B}$	$\frac{\alpha}{1-\alpha}$	+	$\gamma-1$
GAMMA $\gamma$ $G = \frac{\Delta I_E}{\Delta I_B}$	$\frac{1}{1-\alpha}$	$\beta+1$	+

Figure 2-68

CHAPTER 2

Transistor Biasing and Configurations

At times alpha is given and beta is the quantity that is desired. To find beta, use the equation, as shown in figure 2-68, beta is equal to alpha divided by 1 minus alpha. Using the value for alpha just found, 0.95, then beta is equal to 0.95 divided by 1 minus 0.95. Subtracting 0.95 from 1 leaves 0.05, and 0.05 into 0.95 equals a beta of 19, which was the beta originally used.

WHEN T.O. FIND	$\alpha$ KNOWN	$\beta$ KNOWN	$\gamma$ KNOWN
ALPHA $\alpha = \frac{\Delta I_C}{\Delta I_E}$	+	$\frac{\beta}{1+\beta}$	$\frac{\gamma-1}{\gamma}$
BETA $\beta = \frac{\Delta I_C}{\Delta I_B}$	$\frac{\alpha}{1-\alpha}$	+	$\gamma-1$
GAMMA $\gamma = \frac{\Delta I_E}{\Delta I_B}$	$\frac{1}{1-\alpha}$	$\beta+1$	+

Figure 2-69

Sometimes gamma is the quantity desired. Gamma is equal to beta plus 1. As has been shown, with a beta of 19, gamma then is equal to 19 plus 1 which is a gamma of 20.

When the circuit is connected into a configuration so that the signal is being fed in on the base, the ratio or the quantity which is the most important for the technician is beta. While if the signal is being fed in on the emitter, the ratio that will be the most important for the technician to know is alpha. Most transistor manuals give beta for the transistor, and if the circuit demands that you know alpha, it is necessary to convert from beta to alpha. Gamma is, of course, beta plus 1.

Review.

Let us reexamine the common emitter configuration as shown in figure 2-70. The input resistance of a common emitter amplifier is equal to the parallel resistance of  $R_1$  and  $h_{ie}$ . Also  $h_{ie}$  is equal to beta plus 1 times  $h_{ib}$ .

GIVEN:  $\beta = 19$   
 $h_{ib} = 100$

$h_{ie} = (\beta + 1) \times h_{ib}$   
 $h_{ie} = (19 + 1) \times 100 = 2K$   
IF  $R_1 \geq 10 \times h_{ie}$  THEN  $R_{ie} \approx h_{ie}$   
 $R_{ie} \approx 2K$

ALSO:  $h_{ib} = \frac{h_{ie}}{\beta + 1}$

$A_R = \frac{R_o}{R_i} = \frac{10K}{2K} = 5$   
 $\Delta V_{IN} = \Delta I_b \times R_i = .05MA \times 2K$   
 $\Delta V_{IN} \approx 0.1VOLT$   
 $\Delta V_{OUT} = \Delta I_C \times R_L$   
 $= .95MA \times 10K$   
 $\Delta V_{OUT} = 9.5VOLTS$   
 $A_V = \frac{\Delta V_{OUT}}{\Delta V_{IN}} = \frac{9.5}{0.1} = 95$   
 $A_V \approx 95$

ALSO  $A_V = A_R \times \beta = 5 \times 19 = 95$   
 $P_{IN} \approx \Delta I_b \times \Delta V_{IN} = .05MA \times 0.1$   
 $P_{IN} \approx .005MW$   
 $P_{OUT} \approx \Delta I_C \times \Delta V_C$   
 $= .95MA \times 9.5$   
 $P_{OUT} \approx 9.025MW$   
 $A_P = \frac{P_{OUT}}{P_{IN}} \approx \frac{9.025}{.005}$   
 $A_P \approx 1805$

ALSO  $A_P = A_R \times \beta^2 = 5 \times 19^2 = 5 \times 361 = 1805$

Figure 2-70

The voltage gain,  $A_V$ , may be computed either by finding the values of the voltage-in and the voltage-out and dividing the voltage-out by the voltage-in, or by multiplying the resistance gain,  $A_R$ , times beta.

The power gain can be computed by obtaining the power-in and the power-out and dividing the power-out by the power-in, or by multiplying the resistance gain,  $A_R$ , times beta squared. The common emitter amplifier has a resistance gain, voltage gain, power gain, and a phase shift.

GIVEN:  $\alpha = .95$   
SIGNAL IN =  $\Delta I_b = .05MA$

$A_{ic} = \frac{\Delta I_{OUT}}{\Delta I_{IN}} = \frac{\Delta I_c}{\Delta I_b} = \frac{1}{.05}$   
 $A_{ic} = 20$   
 $A_{ic} = \text{GAMMA} (\gamma) = G$   
 $\text{GAMMA} = \beta + 1 = 19 + 1 = 20$   
 $G \times I_b = I_c$   
DISREGARDING  $h_{ie}$  AND  $R_1$   
 $R_i \approx (\beta + 1) \times R_E = (19 + 1) \times 1K$   
 $R_i \approx 20K$   
 $V_{IN} \approx \Delta I_b \times R_i = .05 \times 20K$   
 $V_{IN} \approx 1VOLT$   
 $V_{OUT} \approx \Delta I_c \times R_E = 1MA \times 1K$   
 $V_{OUT} \approx 1VOLT$   
 $A_V = \frac{V_{OUT}}{V_{IN}} = \frac{1}{1} = 1.0$   
 $A_V = 1.0$

USING  $h_{ie}$  DISREGARDING  $R_1$   
 $h_{ie} = (\beta + 1) \times h_{ib} = 20 \times 100$   
 $h_{ie} = 2K$   
 $R_i = (\beta + 1) R_E + h_{ie} = (20 \times 1K) + 2K$   
 $R_i = 22K$   
 $V_{IN} = \Delta I_b \times R_i = .05 \times 22K$   
 $V_{IN} = 1.10$   
 $V_{OUT} = \Delta I_c \times R_E = 1MA \times 1K$   
 $V_{OUT} = 1VOLT$   
 $A_V = \frac{V_{OUT}}{V_{IN}} = \frac{1}{1.10}$   
 $A_V = .909$

Figure 2-71

As shown in figure 2-71, the current gain of a common collector or emitter follower amplifier is equal to gamma. Gamma is equal to beta plus 1. The resistance-in and the voltage gain may be computed disregarding  $h_{ie}$  or by using  $h_{ie}$ . The error involved in disregarding  $h_{ie}$  is only 1 percent in this case. Therefore,  $h_{ie}$  may be disregarded in the computations of input resistance of the common collector or emitter follower configuration. The voltage gain of a common collector is always less than 1 but very near 1.

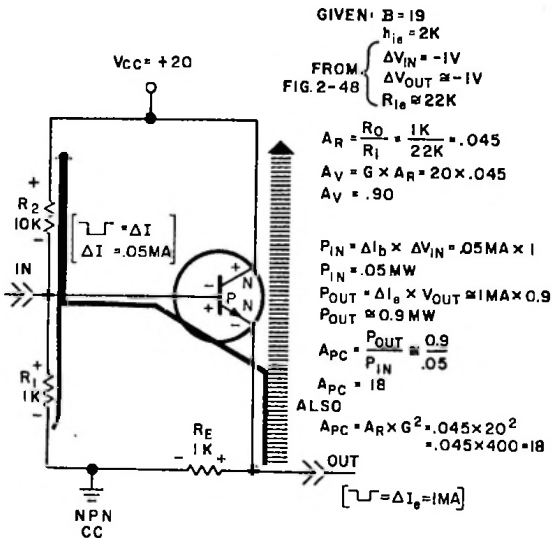

Figure 2-72

Figure 2-72 shows that the voltage gain also may be computed by first finding the resistance gain,  $A_R$ . The voltage gain,  $A_V$ , then is equal to gamma times the resistance gain,  $A_R$ . Although the common emitter amplifier has a voltage gain of less than 1, it does have a power gain. This may be found either by computing the power-in and the power-out and then dividing the power-out by the power-in, or by multiplying the resistance gain,  $A_R$ , times gamma squared. The emitter follower has no phase shift between the input and the output.

Because there is no phase shift between the input and the output and the configuration has a voltage gain close to 1, the stage is called an emitter follower because the emitter follows the base.

Now let us see what we have learned during this chapter. As shown in figure 2-73, the three configurations, common base, CB; common emitter, CE; and common collector or emitter follower, CC, were discussed. It was found that the collector current in an NPN

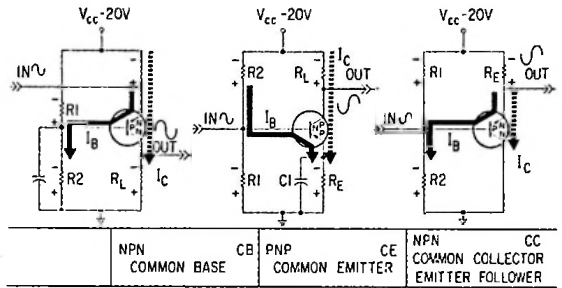

Figure 2-73

flowed from the emitter to the collector, while in a PNP the collector current flowed from the collector to the emitter. It was also found that for correct polarity of bias, the polarity of bias across the base-emitter must match the type of material. A configuration gets its name, common base, common emitter, or common collector, from the item that is common to the input and the output. In other words, in the common base configuration, the base is tied either to a d-c or a-c ground; while in the common emitter, the emitter is tied to either an a-c or d-c ground; and in the common collector, the collector is tied to either an a-c or d-c ground.

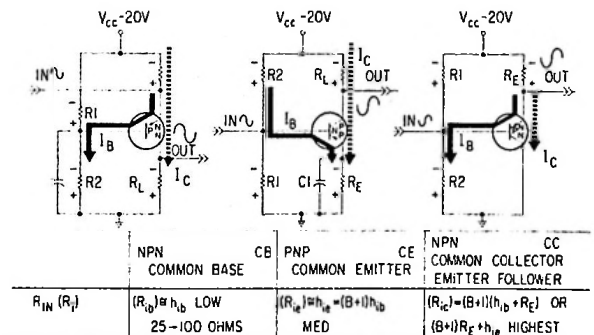

Figure 2-74

Figure 2-74 shows a comparison of the input resistance of the three configurations. The input resistance of a common base, called  $R_{ib}$ , is approximately equal to  $h_{ib}$ , and is usually between 25 and 100 ohms. The input resistance of a common emitter, called  $R_{ie}$ , is approximately equal to  $h_{ie}$ . This quantity is equal to beta plus 1 times  $h_{ib}$ . The input resistance of a common collector, called  $R_{ic}$ , is equal to beta plus 1 times the quantity  $h_{ib}$  plus  $R_E$ , or is equal to beta plus 1 times  $R_E$  plus the quantity  $h_{ie}$ .

Therefore, the common collector has the highest input impedance, and the common base has the lowest input impedance.

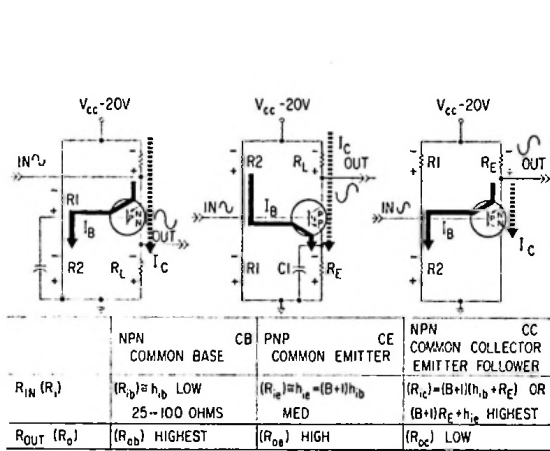

Figure 2-75

In figure 2-75, the output resistances of the three configurations are compared. The output resistances of a common base, called  $R_{ob}$ , are said to be the highest. The reason for this is that  $R_L$  is paralleled by the resistances from the collector to the emitter and  $R_E$ . The total resistances from collector to emitter plus  $R_E$  do not affect  $R_{ob}$  greatly, and therefore normally are disregarded in computations of the output resistance.

The output resistance of a common emitter amplifier, called  $R_{oe}$ , is listed as high. This means that it is not as high as a common base but is very near it. This is because the output resistance is the parallel value of  $R_L$  and the collector to the emitter resistance. The value of  $R_E$  is not included in this because it is bypassed by  $C_1$ . Therefore, the output resistance,  $R_{oe}$ , of a common emitter amplifier will be slightly lower than the output resistance of a common base amplifier. The output resistance of a

common collector or emitter follower is labeled " $R_{oc}$ " and is usually very low. The reason for this is that the output resistance is the parallel value of  $R_E$  and the collector to the emitter resistance. The collector to the emitter resistance normally is quite high, while the value of  $R_E$  usually is kept low, and  $R_E$  therefore determines the value of the output resistance. This means that the common collector or emitter follower configuration normally has the lowest output impedance, while the common base has the highest output impedance.

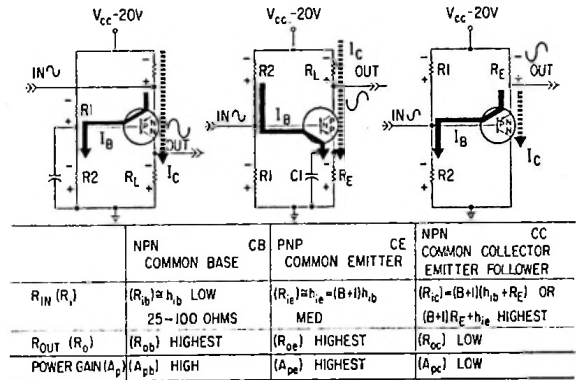

Figure 2-76

Figure 2-76 shows a comparison of the power gain of the three configurations, common base, common emitter, and common collector. The power gain of a common base configuration, called  $A_{pb}$ , was found to be high. The power gain of the common emitter configuration, called  $A_{pe}$ , was found to be highest. This was due to the fact that both a resistance gain and a current gain occurred in the common emitter, while in the common base configuration only a resistance gain occurred. The common collector was found to have the lowest power gain, called  $A_{pc}$ , because it had a resistance loss that thoroughly compensated the current gain. It also had a slight voltage loss. This points out the fact that the resistance gain of a stage is quite important as far as power is concerned.

Figure 2-77 shows a comparison of the voltage gain,  $A_v$ . The voltage gain,  $A_{vb}$ , of the common base was found to be the highest; the voltage gain,  $A_{ve}$ , of the common emitter was found to be high; and the voltage gain,  $A_{vc}$ , of a common collector was found to be less than 1. In actual computations it was found that the

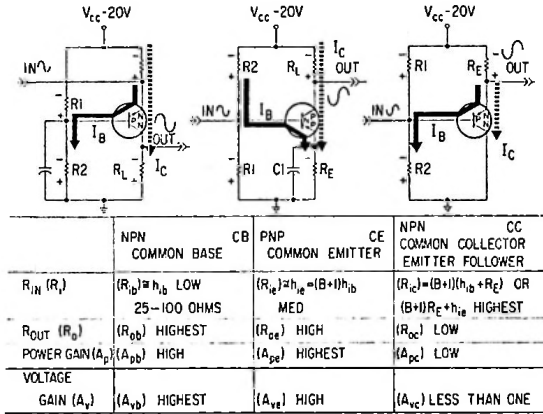

Figure 2-77

common base and the common emitter had the same voltage gain, but it was pointed out that the common emitter always has a voltage gain slightly smaller than the common base and that the error involved was due to the approximate equations used.

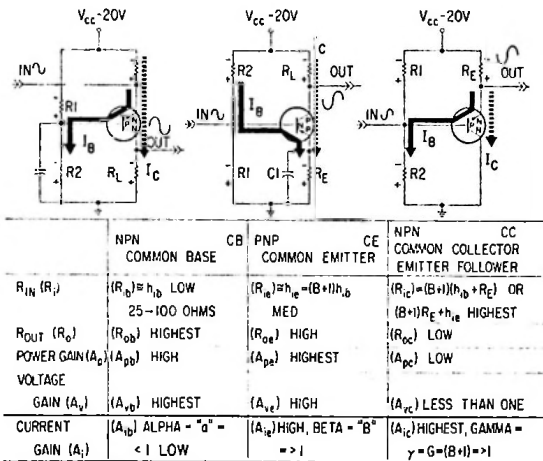

Figure 2-78

Figure 2-78 shows that the common collector has the highest current gain,  $A_{ic}$ . The current gain of a common collector or emitter follower is called gamma and is equal to beta plus 1; therefore, it must always be equal to or greater than 1. The common emitter amplifier has the next highest current gain,  $A_{ie}$ . The current gain of the common emitter amplifier is called beta, and beta is always greater than 1. The common base amplifier has the lowest current gain,  $A_{ib}$ . The current gain of the common base amplifier is equal to alpha, and alpha is always less than 1.

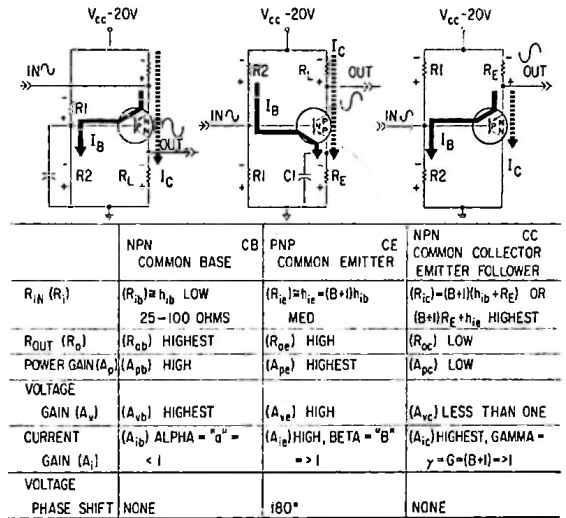

Figure 2-79

Figure 2-79, shows that only the common emitter amplifier has a voltage phase shift. There is no phase shift in the common base or common collector configurations, but there is a 180-degree phase shift in a common emitter amplifier.

### Section 3 Work Problems

Some of the following problems are arranged so that you may conveniently underscore the correct words, or fill in the blanks, or answer thought questions in your own words. Disregard the value of  $R_1$  for all computations of input resistance.

1. List the three configurations in the order of decreasing value.

A.  $A_i$  \_\_\_\_\_

\_\_\_\_\_

\_\_\_\_\_

C.  $A_p$  \_\_\_\_\_

\_\_\_\_\_

\_\_\_\_\_

B.  $A_v$  \_\_\_\_\_

\_\_\_\_\_

\_\_\_\_\_

D.  $R_i$  \_\_\_\_\_

\_\_\_\_\_

\_\_\_\_\_

2. Only the (CE, CB, or CC) configuration has a phase shift.

3. What polarity of signal would it be necessary to inject on the base of a PNP to decrease conduction?

4. What polarity of signal would it be necessary to inject on the emitter of an NPN to cause an increase in conduction?

5. What effect does increasing the value of  $R_E$  in a common emitter amplifier have on the following:

A. Voltage gain?

B. Current gain?

C. Input resistance?

6. What effect does increasing the value of  $R_L$  in a common emitter amplifier have on the following:

A. Voltage gain?

B. Current gain?

C. Input resistance?

7. If  $h_{ib}$  is equal to 75 ohms and beta equals 57, what will  $h_{ie}$  equal? (Show your work.)



CHAPTER 2  
Transistor Biasing and Configurations

8. Figure 2-80 is (a PNP or an NPN) common (base, emitter, or collector) configuration.

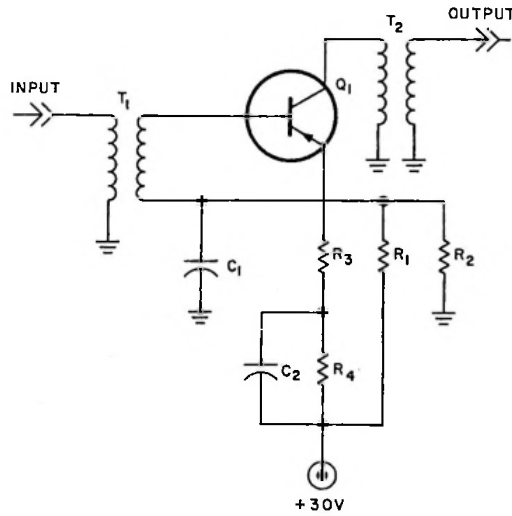

Figure 2-80

9. If the polarity of the supply in figure 2-80 were reversed, what type of transistor would be necessary to replace  $Q_1$ ?
10. The phase of the signal at the output of figure 2-81 is (in phase or out of phase) with the signal at the input.

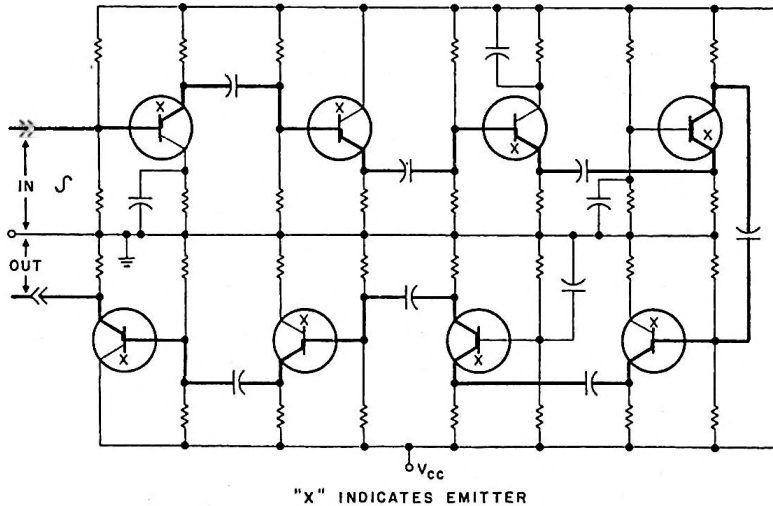

Figure 2-81

11. Substituting the values given here for those in figure 2-43, solve for  $A_i$ ,  $R_i$ ,  $A_v$ , and  $A_p$ . Disregard the value of  $R_1$  in all computations. (Show your work.)

- $R_1 = 10K$
- $R_2 = 50K$
- $R_L = 5K$
- $R_E = 3K$

- $C_1 = 40 \text{ mfd}$  which = a-c short
- Alpha = 0.995
- hib = 50 ohms

A. Find  $A_i$

B. Find  $R_i$

C. Find  $A_v$

D. Find  $A_p$

12. Substituting the values given here for those in figure 2-56, solve for  $A_i$ ,  $R_i$ ,  $A_v$ , and  $A_p$ . Disregard the value of  $R_1$  and  $h_{ib}$ . (Show your work.)

$$\begin{aligned}R_1 &= 5K \\R_2 &= 20K \\R_E &= 2K\end{aligned}$$

$$\begin{aligned}\text{Beta} &= 60 \\h_{ib} &= 25 \text{ ohms}\end{aligned}$$

A. Find  $A_i$

B. Find  $R_i$

C. Find  $A_v$

D. Find  $A_p$

As soon as you have answered each of the above questions to the best of your ability, you are ready to proceed to section 4 of the tape-slide presentation, where the work problems will be reviewed and the correct answers given.

### Introduction.

Chapter 3 contains a detailed discussion on bias stabilization, the effects of temperature upon the transistor and its operating parameters.

The first half of chapter 3 discusses the bias stabilization of the base-emitter junction. Also included in the first half of chapter 3 is a detailed discussion of the computations for the quiescent base current, collector current, emitter current, base voltage, emitter voltage, and collector voltage.

### D-C Computations.

Because bias stabilization is a problem, an entire chapter is devoted to it.

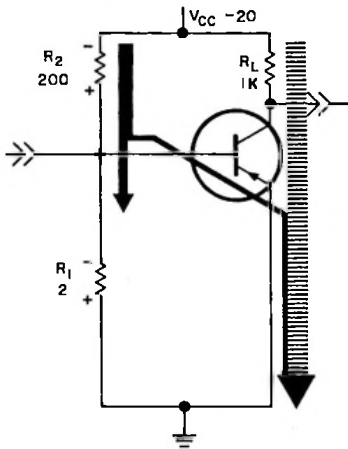

Figure 3-1

Figure 3-1 shows a common emitter PNP-type circuit. Notice that the values of  $R_2$  and  $R_1$  are quite low. Also notice that only a very small portion of the total current flowing through  $R_2$  and  $R_1$  flows in the base of the transistor.

The question might arise, "Is this circuit correctly biased?" Applying the rules to determine the correct biasing of a transistor, first determine the type of

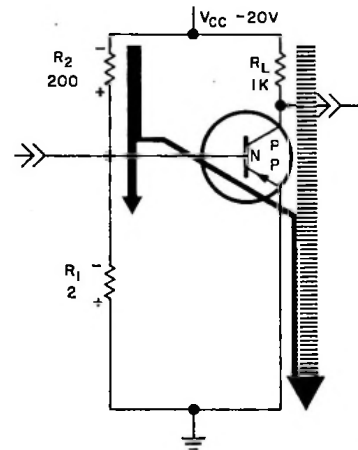

Figure 3-2

transistor. Because the arrow is pointing toward the base region, this transistor is a PNP transistor. Next, write in the letters "P-N-P" on the back side of the transistor symbol as shown in figure 3-2.

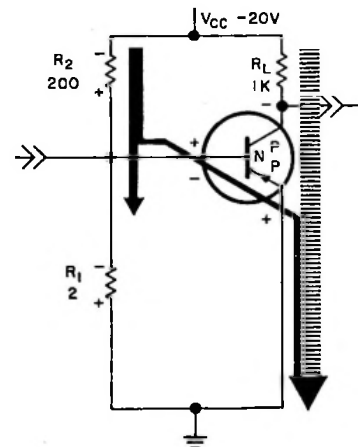

Figure 3-3

CHAPTER 3  
Bias Stabilization

After determining the type of transistor and writing in the letters on the back side of the transistor symbol, mark the polarities of the bias desired across the transistor on the front side of the transistor symbol as shown in figure 3-3. Starting at the emitter and matching the polarity of the bias with the type of material, positive in this case to match the "P" type material, go in series toward the collector, positive, negative, positive, negative, as indicated in figure 3-3.

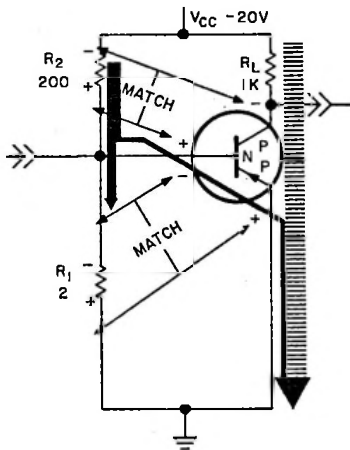

Figure 3-4

As can be seen in figure 3-4, the polarities of the voltages, dropped across  $R_2$  and  $R_1$ , match the polarities desired for correct biasing of the transistor. Therefore, this transistor is biased correctly and the transistor is turned on to some extent.

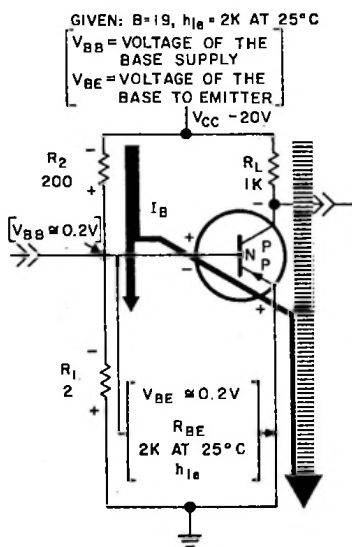

Figure 3-5

Now examine figure 3-5. Several new terms are used here and should be defined before continuing further.  $V_{BB}$  indicates the voltage of the base supply. This voltage could be from a second source or from a voltage-dividing network similar to the one shown here. In any case, it is the voltage supplied to the base circuit but is not necessarily the voltage on the base.  $V_{BE}$  is the voltage of the base-to-emitter junction. This is the voltage that is found from the base to the emitter of a transistor.  $R_{BE}$ , another new term, is the resistance from the base to the emitter of a transistor and can be equal to either  $h_{ie}$  or  $h_{ib}$ , depending upon which lead of the transistor receives the input signal. Because the signal is being inserted on the base lead of the transistor in this case,  $R_{BE}$  is equal to  $h_{ie}$ .  $R_{BE}$  changes as a function of temperature. As temperature increases,  $R_{BE}$  decreases. If the voltage,  $V_{BE}$ , is known and the resistance,  $R_{BE}$ , is also known, the current,  $I_B$ , can be computed. With no resistance,  $R_E$ , in series with the emitter, the voltage from base to emitter,  $V_{BE}$ , must be equal to  $V_{BB}$ .  $V_{BB}$  can be computed by assuming that the base lead is an open, and also assuming that the resistance network,  $R_1$  and  $R_2$ , determines the voltage at the base. In figure 3-5,  $V_{BB}$  would be approximately equal to 0.2 volt.

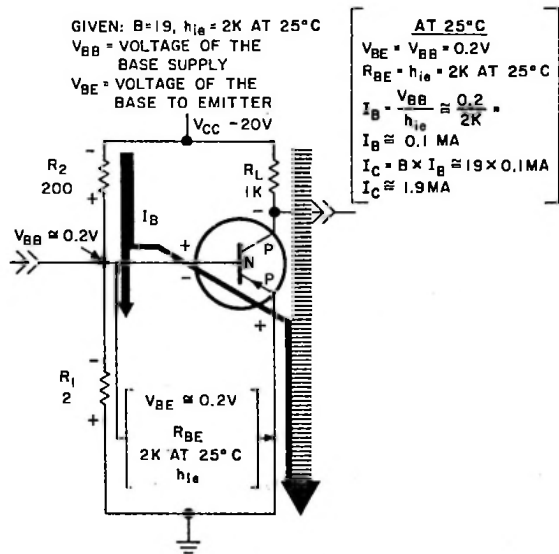

Figure 3-6

Examine figure 3-6 for computations of the base current and collector current at 25°C. The voltage from base to emitter,  $V_{BE}$ , is equal to the voltage of the base supply,  $V_{BB}$ , which equals 0.2 volt. The transistor manual states that at 25°C the resistance from base to emitter,  $h_{ie}$ , is equal to 2K.  $I_B$  can be computed by dividing the voltage of the base supply,  $V_{BB}$ , by the resistance from base to emitter,  $R_{BE}$  or  $h_{ie}$ . As previously stated, the voltage of the base supply is equal to 0.2 volt, while  $h_{ie}$  is equal to 2K. Therefore,  $I_B$  equals 0.2 divided by 2K, or approximately 0.1 milliamperes. The collector current,  $I_C$ ,

can be computed by multiplying beta times  $I_B$ . Beta is given as being equal to 19. Therefore, 19 times 0.1 milliampere equals the collector current,  $I_C$ , of approximately 1.9 milliamperes.

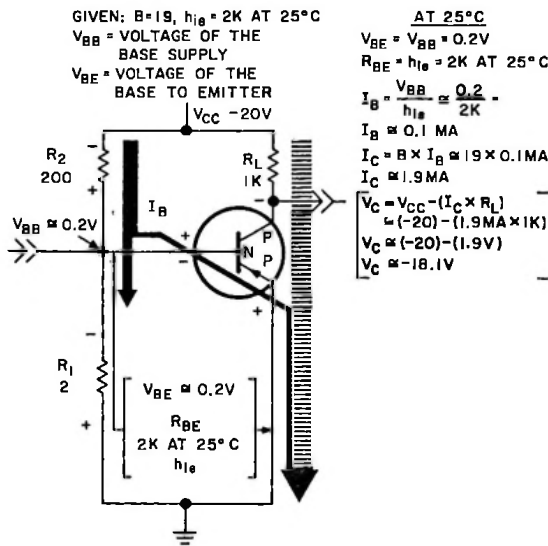

Figure 3-7

Once the collector current is known, the collector voltage,  $V_C$ , can be computed as shown in figure 3-7.  $V_C$  is equal to  $V_{CC}$  minus the quantity  $I_C$  times  $R_L$ . Therefore,  $V_C$  is equal to the quantity minus 20 volts, minus the quantity 1.9 milliamperes times 1K. 1.9 milliamperes times 1K is equal to 1.9 volts.  $V_C$  then is equal to a minus 20 volts minus 1.9 volts. By subtracting 1.9 volts from a minus 20 volts, the quiescent collector voltage,  $V_C$ , is found to be equal to a minus 18.1 volts.

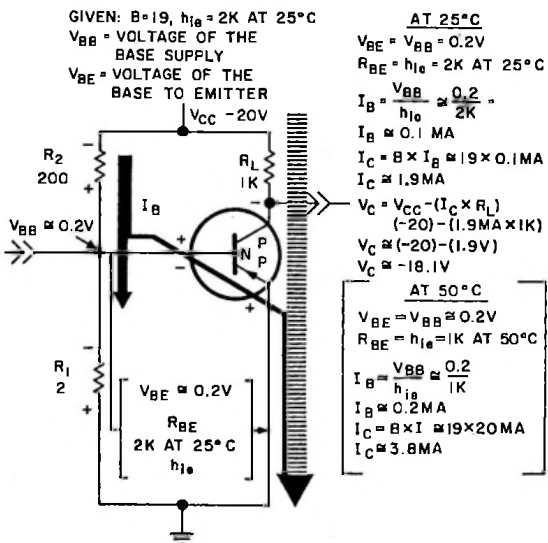

Figure 3-8

If the temperature of the junction were to be increased to  $50^\circ C$ , as in figure 3-8, then  $h_{ie}$  would decrease. Assuming that  $h_{ie}$  decreased to 1K then the base current,  $I_B$ , would change.  $I_B$  is equal to  $V_{BE}$ , which is still 0.2 volt divided by  $h_{ie}$ . This is approximately equal to 0.2 divided by 1K, and  $I_B$  is approximately equal to 0.2 milliampere. The collector current,  $I_C$ , is equal to beta times  $I_B$  and can be found by multiplying 19 times 0.2 milliampere. The value for  $I_C$  at  $50^\circ C$  then is found to be equal to 3.8 milliamperes.

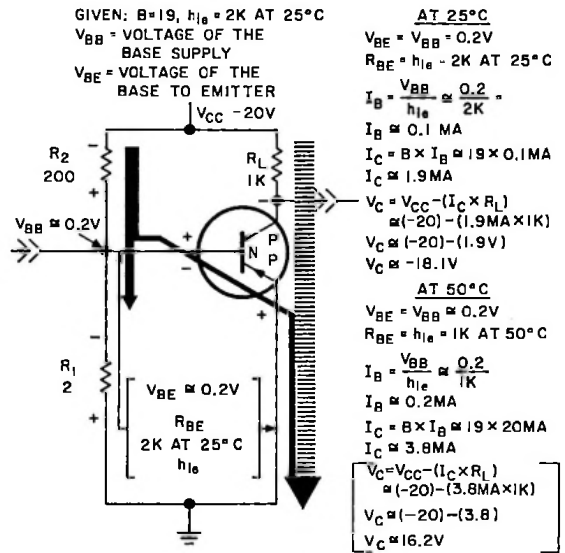

Figure 3-9

The voltage on the collector,  $V_C$ , then can be calculated as shown in figure 3-9.  $V_C$  is equal to  $V_{CC}$  minus the quantity  $I_C$  times  $R_L$ . This means that the voltage on the collector is equal to a minus 20 volts, minus the quantity 3.8 milliamperes times 1K, or minus 20 volts minus the quantity 3.8. Therefore,  $V_C$  is approximately equal to a minus 16.2 volts.

Notice that there is no change in  $V_{BB}$  even though  $R_{BE}$  decreases to one half its original value. This is due to the fact that  $R_1$  is less than one tenth the base-emitter resistance, and even though there is a change in the resistance of the base-emitter junction, it will not affect the voltage at the base. The resistance of the base-emitter junction decreases as the temperature of the transistor is increased, because the base-emitter junction has a negative temperature coefficient. As temperature increases, there is a decrease in resistance. As the resistance decreases to 1K at  $50^\circ C$ , and the voltage  $V_{BE}$  remains constant, the current from the base to the emitter,  $I_B$ , increases to approximately 1.2 mills. This increase in the base-emitter current increases the

CHAPTER 3  
Bias Stabilization

collector current,  $I_C$ , as a product of beta, to approximately 3.8 mills. This causes the quiescent collector voltage,  $V_C$ , to change to approximately minus 16.2 volts and represents a change of almost 2 volts. This is undesirable since, if the collector current,  $I_C$ , increase is due only to temperature, then the output voltage change is due only to temperature. If the junction temperature were to change at a 60-cycle rate with this bias arrangement, the output voltage would vary at a 60-cycle rate with no signal-in. This is an undesirable effect of transistors and must be compensated for. The base-emitter resistance of a transistor decreases at a rate so that the voltage from the base to the emitter,  $V_{BE}$ , must decrease at approximately 2 millivolts per degrees centigrade of increase in temperature to maintain a constant current through the base-emitter.

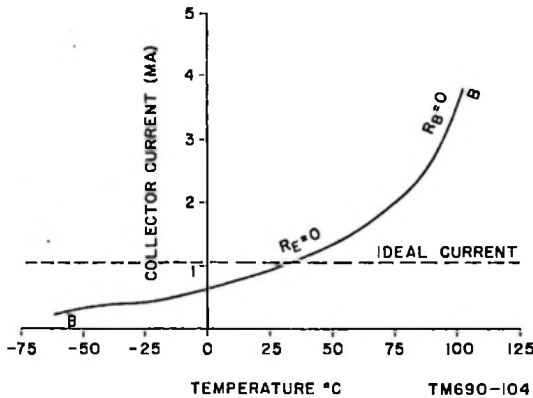

Figure 3-10

Figure 3-10 shows a plot of the variations in the collector current,  $I_C$ , due only to temperature. The curve is plotted for a value of  $R_E$  of zero, and a parallel value of  $R_1$  and  $R_2$  equal to zero also. Although in the circuit previously shown,  $R_B$ , the parallel value of  $R_1$  and  $R_2$ , was not equal to zero, it was near zero.

Note that at a minus 25°C, the collector current is approximately 0.5 mill, while at 75°C the collector current is approximately 2 mills. This represents a 1.5-mill change in the collector current. This change in the collector current is caused because the voltage on the base,  $V_{BE}$ , did not decrease as the resistance,  $R_{BE}$ , decreased. As stated previously, for ideal circuit operation, the voltage from base to emitter,  $V_{BE}$ , should decrease at approximately 2 millivolts per degree centigrade of increase in temperature.

Temperature Stabilization of the Base-Emitter Junction with Resistors.

One solution to the problem of temperature stabilization would be to insert a large amount of resistance in series with  $I_B$  to cause the base current,  $I_B$ , to be relatively constant even if the base-emitter resistance were to change. This could be done, as shown in figure 3-11, by increasing the value of  $R_1$  and  $R_2$ .

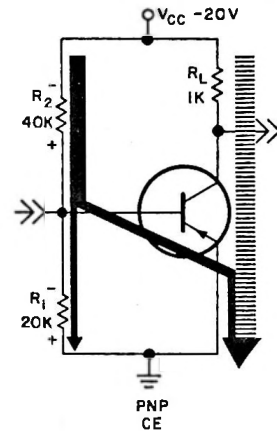

Figure 3-11

If  $R_2$  were to be 10 times the d-c  $R_{in}$  of the transistor, then almost all of the current flowing through  $R_2$  would also flow through the base emitter. Any change in the base-emitter resistance will have very little effect upon the total resistance that the power supplies see to ground.

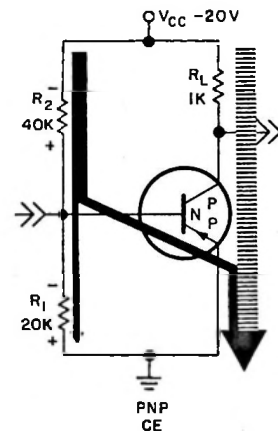

Figure 3-12

Before examining this circuit for the operating parameters, check to see if the circuit is biased correctly. The first step in determining whether the transistor is biased correctly is to determine the type of transistor. Because the arrow of the transistor, in figure 3-12, is pointing toward the base symbol, the transistor must be a PNP transistor. These letters are then marked in on the back side of the transistor symbol as shown in figure 3-12.

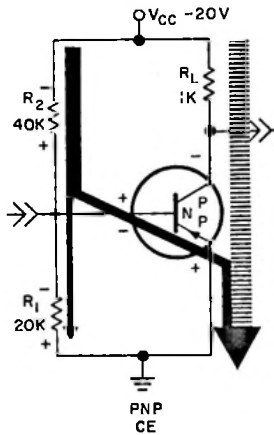

Figure 3-13

The next step, as shown in figure 3-13, is to mark the polarity of the bias desired for the transistor on the front side of the transistor symbol. To do this, start at the emitter and match the polarity of the voltage at that point with the polarity indicated by the type of material. Because the transistor under discussion is a PNP, the emitter is "P" type material. Therefore, the polarity of voltage desired at the emitter is positive. From the emitter, the voltages should go in series, positive, negative, positive, negative, as shown.

After determining the polarity of bias required by the transistor for correct biasing, determine whether these polarities are available from the biasing circuit. As shown in figure 3-14, the polarity of the voltage dropped across  $R_2$  matches the polarity desired across the base-to-collector junction. Also, the polarity of the voltage dropped across  $R_1$  matches the polarity of the voltage desired across the base-emitter junction.

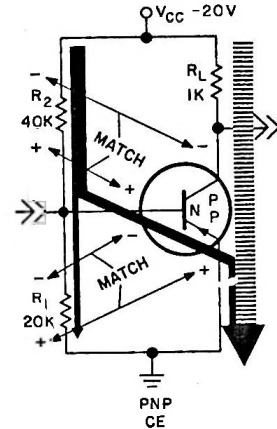

Figure 3-14

The transistor, shown in figure 3-15, is assumed to have a beta equal to 20 and a base-emitter resistance,  $h_{ie}$ , equal to 2K ohms at 25°C.  $I_B$  can be found by assuming that no current flows through  $R_1$  and that the entire current flowing through  $R_2$  is also flowing in the base. In other words, the current through  $R_2$  is equal to  $I_B$ . If  $R_1$  is large compared to the base-emitter resistance, the voltage at the base becomes dependent upon  $R_{BE}$ , and any change in the value of  $R_{BE}$  will have a very little effect on the current in the circuit. Therefore,  $I_B$  will remain relatively constant, causing  $I_C$  to remain relatively constant. Of course, if the current,  $I_B$ , remains relatively constant and the base emitter resistance decreases,  $V_{BE}$  will decrease. Ideally it

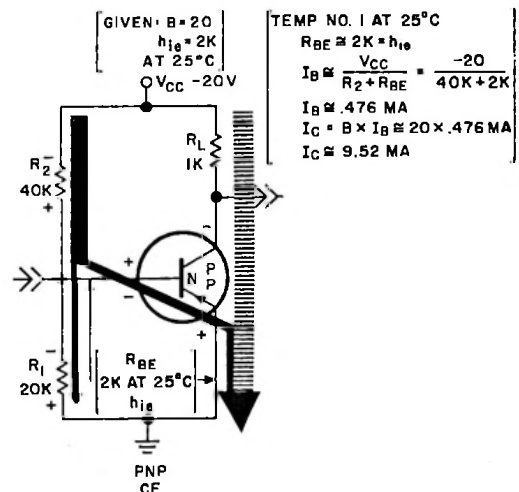

Figure 3-15

would decrease at the rate of 2 millivolts per degree centigrade of increase in temperature. The ideal condition cannot happen as it is a foregone conclusion that the current in the circuit,  $I_B$ , will increase as the over-all circuit resistance decreases.

This slight increase in base current, though, can usually be disregarded as it will cause only a negligible change in  $V_C$ . This can be shown by examining the operating parameters of the circuits at two different temperatures. At 25°C, the base current,  $I_B$ , can be calculated by dividing the collector supply voltage by the total resistance of  $R_2$  plus  $R_{BE}$ . For the circuit under discussion,  $I_B$  is equal to a minus 20 divided by the quantity 40K plus 2K.  $I_B$  is then equal to 0.476 milliamperes. To find  $I_C$  it is only necessary to multiply beta times  $I_B$ , because beta is the ratio of  $I_C$  to  $I_B$  and beta times  $I_B$  equals  $I_C$ . Therefore, 20 times 0.476 milliamperes is  $I_C$  and is equal to 9.52 milliamperes.

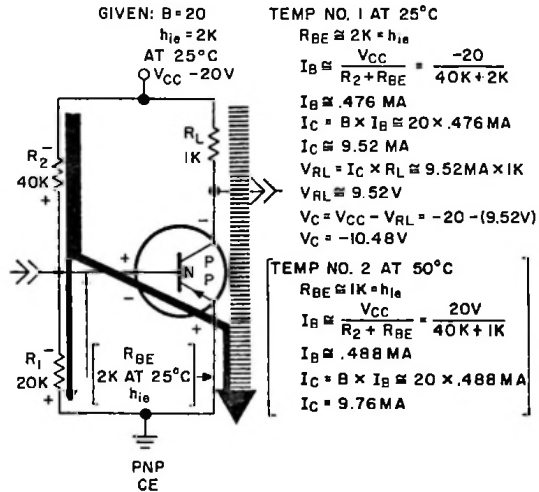

Figure 3-17

If the resistance of the base to emitter were to decrease to 1K ohm, as in figure 3-17, the voltage from the base to the emitter would also decrease, and the current through the entire system of  $R_2$  and the base-emitter resistance would remain approximately constant over a wide range of change in the base-emitter resistance. Assume that the base-emitter resistance changed from 2K ohms to 1K ohm. This is a decrease in the base-emitter resistance of one half. Using the first method of biasing, the current through the base emitter would almost double. In the method that is now being examined, a total circuit resistance change of 1K ohm, out of the total resistance of  $R_2$  plus the base-emitter resistance of 42K, exists. At temperature number 2, 50°C, it is found that there is 41K ohms of total resistance. This results in a base current,  $I_B$ , of 0.488 milliamperes. To find  $I_C$ , it is only necessary to multiply beta times  $I_B$ , because beta is the ratio of  $I_C$  to  $I_B$  and beta times  $I_B$  equals  $I_C$ . Therefore,  $I_C$  is equal to 20 times 0.488 milliamperes, which equals a value for  $I_C$  of approximately 9.76 milliamperes.

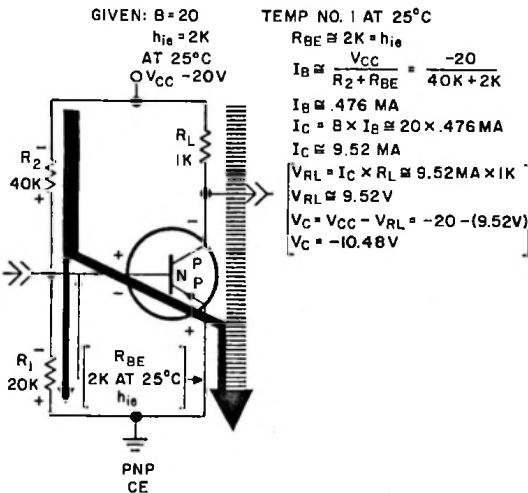

Figure 3-16

$I_C$  is flowing through  $R_L$ , and because the value of  $R_L$  is known, the voltage drop across  $R_L$  may be found as shown in figure 3-16. In this case, this voltage is equal to 9.52 milliamperes times 1K, or  $V_{RL}$  is equal to 9.52 volts. This is the voltage drop across  $R_L$ . To obtain  $V_C$ , subtract  $V_{RL}$  from  $V_{CC}$ . Subtracting 9.52 volts from a minus 20 volts gives the collector voltage,  $V_C$ , of a minus 10.48 volts. Now the original problem was that as temperature increases, the voltage from the base to the emitter must decrease at 2 millivolts per degree centigrade to maintain a constant current from the base to the emitter. By increasing the value of  $R_2$  to 40K, the voltage at the junction of  $R_1$  and  $R_2$  becomes dependent upon the resistance from the base to the emitter.

Once the value of  $I_C$  is known, the voltage drop across  $R_L$  can be found as shown in figure 3-18. The voltage drop across  $R_L$ ,  $V_{RL}$ , is equal to  $I_C$  times  $R_L$ . Multiplying 9.76 milliamperes times 1K gives a value of 9.76 volts for  $V_{RL}$ . Remember, this is only the voltage drop across  $R_L$ . By subtracting the value of  $V_{RL}$  from  $V_{CC}$ , the value of the collector-to-ground voltage can be found. Subtracting 9.76 from the collector supply voltage of a minus 20 volts results in a value for  $V_C$  of a minus 10.24 volts. Notice that the collector voltage change in these two conditions is very minor. The total difference in the collector voltage from 25°C to 50°C is 0.24 volt. Therefore, the base-emitter resistance change did not cause an



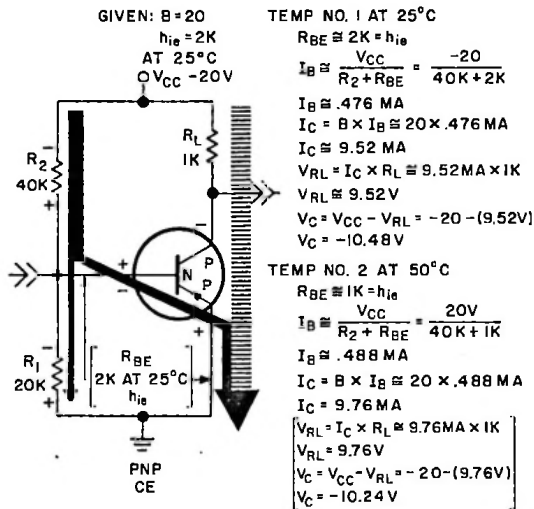

Figure 3-18

appreciable change in the collector voltage. The base-emitter resistance change is said to be "swamped" by  $R_2$ , because the high value of  $R_2$  causes any change in the base-emitter resistance to be very minor compared to the total resistance in series with  $I_B$ .

To approximate the value of  $I_B$ , when  $h_{ie}$  is unknown and  $R_1$  is greater than 10 times the expected input impedance of the transistor, it is allowable to assume that  $R_1$  is an open and the base to the emitter voltage equals zero volt. For the circuit shown, this means that the entire voltage,  $V_{CC}$ , is dropped across  $R_2$  and that the current flowing through  $R_2$  is the base current. This will give a value of 0.5 milliamperes for  $I_B$ . The error involved in using this value for  $I_B$  will cause less than 0.5 volt error in  $V_C$ . This method is allowable for rough approximations, because the voltage from base to emitter usually is quite small and is approximately 0.2 volt for germanium and 0.8 volt for silicon. Therefore, disregarding this quantity does not cause a large error in the computations. Also, if  $R_1$  is greater than 10 times the input resistance of the transistor, only a fractional amount of the current flowing through  $R_2$  flows through  $R_1$ , and this current may be disregarded without causing a large error in the computations.

Although increasing the value of  $R_2$  did stabilize the base-emitter junction for temperature changes, a better method of doing this would be to place a resistor in the emitter of the transistor, and decrease the value of  $R_1$  and  $R_2$  to small values of resistances as shown in figure 3-19. The reason that this is a better method will be explained during the discussion on bias stabilization due to  $I_{CBO}$ . When a resistor is placed in the emitter of a common emitter amplifier, it is usually bypassed by a capacitor to prevent

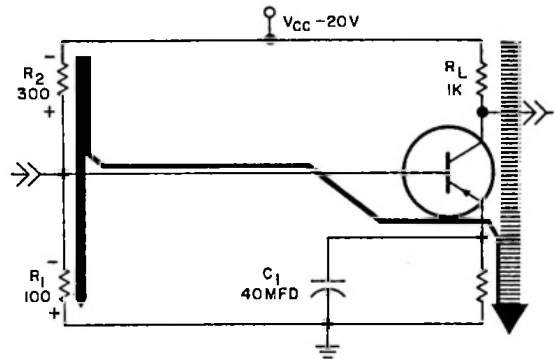

Figure 3-19

degeneration of the signal. Before discussing the effect of  $R_E$  on bias stabilization of the base-emitter junction, first examine the circuit to see if the correct polarities of bias have been applied to the transistor.

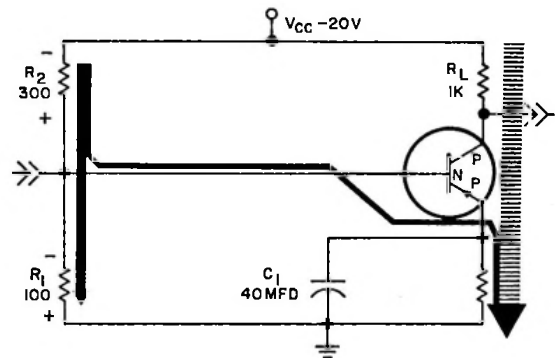

Figure 3-20

The first step in determining the correct bias for the transistor is to determine the type of transistor. As shown in figure 3-20, the emitter lead arrow is pointing toward the base region. Therefore, the transistor must be a PNP. Write these letters in on the back side of the transistor symbol as shown in figure 3-20.

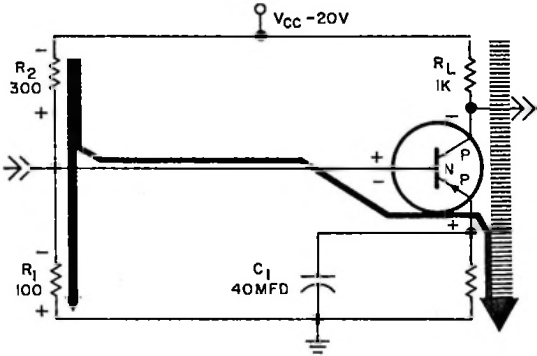

Figure 3-21

The next step, as shown in figure 3-21, is to mark the correct polarity of bias that is desired for normal operation of the transistor on the front side of the transistor symbol. To do this, start at the emitter and match the polarity of the bias to the type of material. In figure 3-21 the emitter is "P" type material. Therefore, the polarity of the voltage at the emitter should be positive, and the polarities should go in series from this point, positive, negative, positive, negative, from the emitter to the collector as shown in figure 3-21.

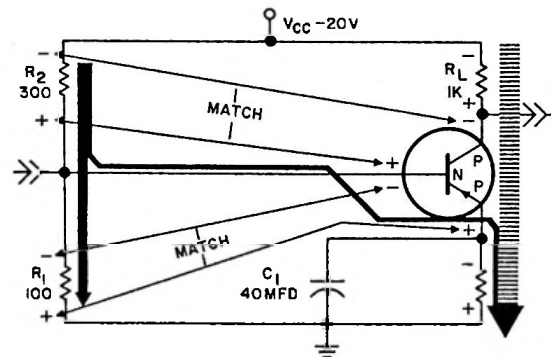
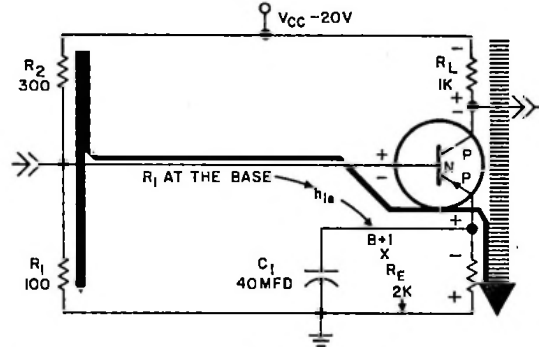

Figure 3-22

After determining the correct polarity of bias for the transistor, check the circuit supplying the bias polarities. As shown in figure 3-22, the polarity of voltage drop across  $R_2$  matches the polarity of voltage desired across the base-collector junction, and the base-collector junction is biased correctly. Additionally the voltage drop across  $R_1$  matches the polarity of voltage desired across the base-emitter junction. Therefore, the transistor in this circuit is biased correctly.



NOTE:  $V_{BB}$  IS NOT DEPENDENT UPON THE TRANSISTOR AS THE  $R_1$  AT THE BASE IS  $> 10 \times R_1$

GIVEN:  $\beta = 20$   
 $h_{ie} = 2K$  AT  $25^\circ C$   
 $h_{ie} = 1K$  AT  $50^\circ C$

AT  $25^\circ C$   
 $R_1$  AT THE BASE  $[(\beta+1) \times R_E] + h_{ie}$  AT  $25^\circ C$  OR,  $21 \times 2K + 2K = 44K$

Figure 3-23

To compensate for changes in the base-emitter resistance due to temperature changes, it is necessary to place a high resistance in series with the base-current path. In the previous circuit this was done by increasing the values of  $R_2$  and  $R_1$ . This also can be done, as shown in figure 3-23, by placing a resistor in the emitter lead of the transistor as shown. If the value of  $R_E$  were 2K ohms, the resistance looking into the base then would be beta plus 1 times  $R_E$  plus the resistance from base to the emitter,  $h_{ie}$ ; or in this case, at  $25^\circ C$ ,  $R_1$  is equal to 20 plus 1 times 2K, a total of 42K ohms plus the 2K ohms base-emitter resistance,  $h_{ie}$ . This is a total of 44K ohms resistance from the base to ground.

Therefore, if the base-emitter resistance were to decrease by 1K ohm, as in figure 3-24, due to the temperature increasing to  $50^\circ C$ , the total resistance change would be from 44K to 43K ohms. This would cause the current, through the circuit, to remain almost constant even though the resistance of the base-emitter decreased by one half. Also, if the base-to-emitter resistance decreases as temperature increases, more voltage will be dropped across  $R_E$ , and less voltage will be dropped across the base-emitter junction. This decrease in  $V_{BE}$  is what

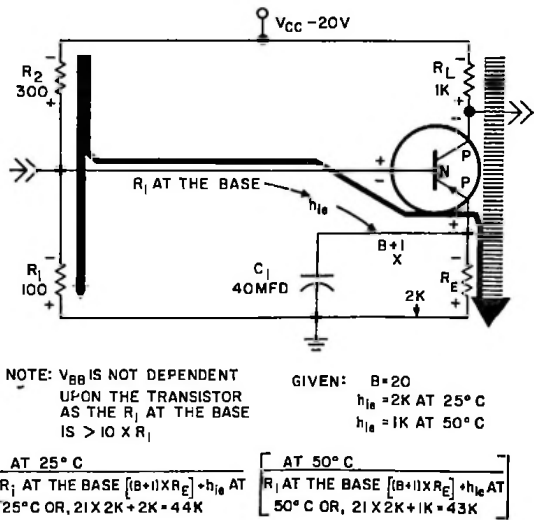

Figure 3-24

we were originally trying to achieve. As was previously stated, when  $R_E$  is used for this purpose, it normally is bypassed with a capacitor to prevent degeneration on a-c signals, and is known as an emitter swamping resistor.

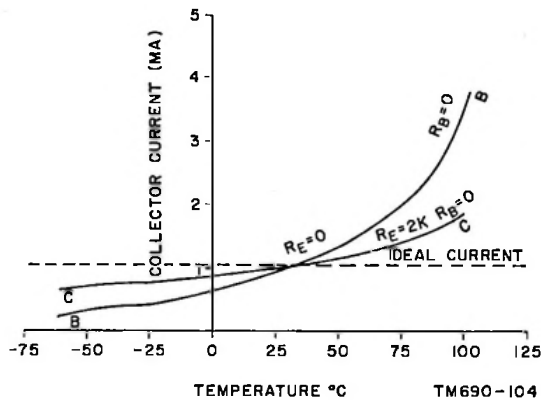

Figure 3-25

In figure 3-25, curve "C" shows a large improvement in the bias stabilization of the transistor if  $R_E$  is increased to 2K, and  $R_B$ , the parallel resistance of  $R_1$  and  $R_2$ , is maintained near zero as in the previous figure. Although there is still some change in the collector current for a change in temperature, this change is not as great as the change that occurred in

curve "B" when  $R_E$  was equal to zero and  $R_B$ , the parallel resistance of  $R_1$  and  $R_2$ , was near zero. Increasing the value of  $R_E$  to 2K instead of increasing the value of  $R_2$  does a slightly better job of bias stabilization.

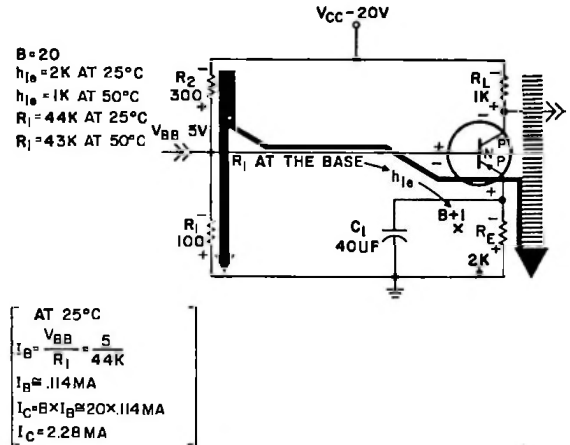

Figure 3-26

This can be shown by computing the quiescent operating voltages and currents of the transistor at different values of  $h_{ie}$  which change as a function of temperature. Figure 3-26 shows the computations for  $I_B$  and  $I_C$  at  $25^\circ C$ . The information that beta of this transistor is equal to 20 and that  $h_{ie}$  is equal to 2K at  $25^\circ C$  and 1K at  $50^\circ C$  is obtained from figure 3-24. Also,  $R_1$  is equal to 44K at  $25^\circ C$  and 43K at  $50^\circ C$ . The voltage of the base supply,  $V_{BB}$ , is equal to 5 volts due to the voltage-dividing network,  $R_1$  and  $R_2$ .  $I_B$  then can be computed by dividing  $V_{BB}$  by the value of  $R_1$  at  $25^\circ C$ . The value of  $R_1$  at  $25^\circ C$  was found in figure 3-24 to be equal to 44K. Therefore,  $I_B$  is equal to 5 volts, the value of  $V_{BB}$ , divided by 44K.  $I_B$  is then approximately equal to 0.114 milliamperes. Because beta is the ratio of  $I_C$  to  $I_B$ , beta times  $I_B$  equals  $I_C$ .  $I_C$  then is equal to 20 times 0.114 milliamperes or 2.28 milliamperes.

Once the collector current is known, the collector voltage may be calculated, as indicated in figure 3-27, by finding the voltage drop across  $R_L$  and subtracting this from the collector supply. The voltage drop across  $R_L$ ,  $V_{RL}$ , can be found by multiplying the collector current times the resistance of  $R_L$ . For this circuit,  $V_{RL}$  is equal to 2.28 milliamperes times 1K. This equals 2.28 volts for the voltage drop across  $R_L$ . Subtracting this quantity from a  $V_{CC}$  of minus 20 volts, the quiescent voltage,  $V_C$ , is found to be equal to minus 17.72 volts. This is the value

CHAPTER 3  
Bias Stabilization

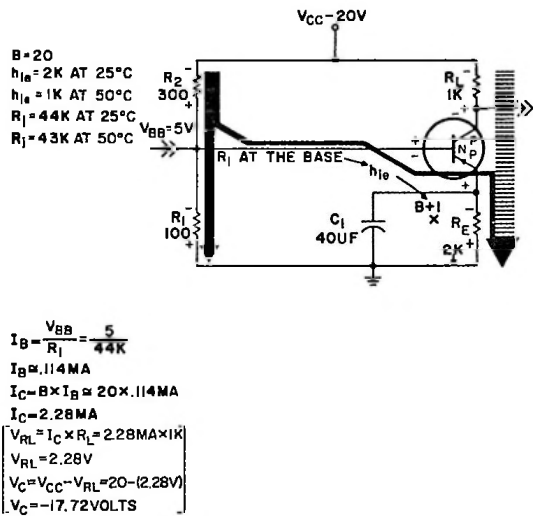

Figure 3-27

of the quiescent operating currents and voltages at 25°C. At 25°C,  $h_{ie}$  has a value of 2K ohms. Examine the circuit for a worst case condition, where the value of  $h_{ie}$  is decreased to zero.

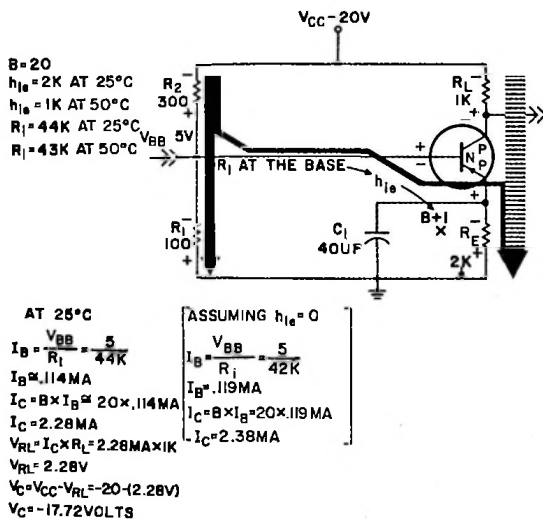

Figure 3-28

In figure 3-28, the computations for a worst case condition, where  $h_{ie}$  is equal to zero, is shown for  $I_B$  and  $I_C$ . With  $h_{ie}$  equal to zero,  $R_1$  is then equal to 42K. The voltage at the base,  $V_{BB}$ , is still equal to 5, so  $I_B$  is equal to 5 divided by 42K. Therefore,  $I_B$  is equal to 0.119 milliampere.  $I_C$  can now be computed by multiplying beta, which is 20 for this

transistor, times 0.119 milliampere, the base current just computed.  $I_C$ , therefore, is equal to 2.38 milliamperes.

Now that the collector current has been calculated, the voltage drop across  $R_L$  can be found, as shown in figure 3-29, by multiplying this collector current times the value of  $R_L$ . 2.38 milliamperes times 1K equals 2.38 volts. Therefore, the voltage drop across  $R_L$ ,  $V_{RL}$ , is equal to 2.38 volts. Remember this is not the collector voltage but is the amount of voltage dropped across  $R_L$ , and to find the collector voltage subtract  $V_{RL}$  from  $V_{CC}$ . Subtracting 2.38 from a minus 20 volts gives  $V_C$  a value of negative 17.62 volts.

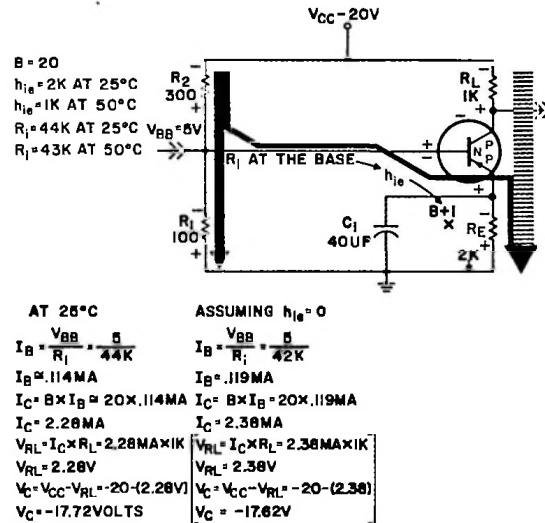

Figure 3-29

By comparing the value obtained here with that obtained for the circuit at 25°C, it can be seen that under worst case conditions, where  $h_{ie}$  would be decreased to zero ohm, the change in the collector voltage would only be 0.1 volt. It is rather improbable that  $h_{ie}$  would ever decrease to zero. A more practical outlook would be to compute the value of the quiescent operating voltages and currents at 50°C where  $h_{ie}$  is equal 1K.

In figure 3-30 the computations for the quiescent base current and collector current are given for the circuit at 50°C using a value of 1K for  $h_{ie}$ . At 50°C  $R_1$  will be equal to 43K. Therefore,  $I_B$  is equal to 5 divided by 43K. Dividing 5 by 43K gives a value of approximately 0.116 milliampere for  $I_B$ . Therefore, 20 times 0.116 milliampere equals  $I_C$ , which equals 2.32 milliamperes.

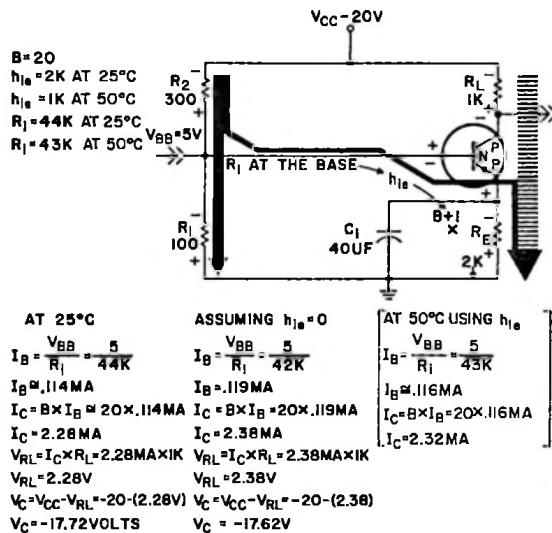

Figure 3-30

The voltage across  $R_L$  can be found, as shown in figure 3-31, by multiplying  $I_C$  times  $R_L$ .  $V_{RL}$  then equals 2.32 milliamperes times 1K. Therefore,  $V_{RL}$  equals 2.32 volts. By subtracting  $V_{RL}$  from  $V_{CC}$ , the voltage on the collector,  $V_C$ , can be found. Subtracting 2.32 volts from the collector supply of a minus 20 volts leaves a minus 17.68 volts. Therefore, the collector voltage,  $V_C$ , is equal to a minus 17.68 volts at 50°C, assuming that  $h_{ie}$  equals 1K. Compare this with the value obtained for  $V_C$  at 25°C. As you can see, there is only 0.04 volt difference. This indicates that the base-emitter junction is relatively well stabilized.

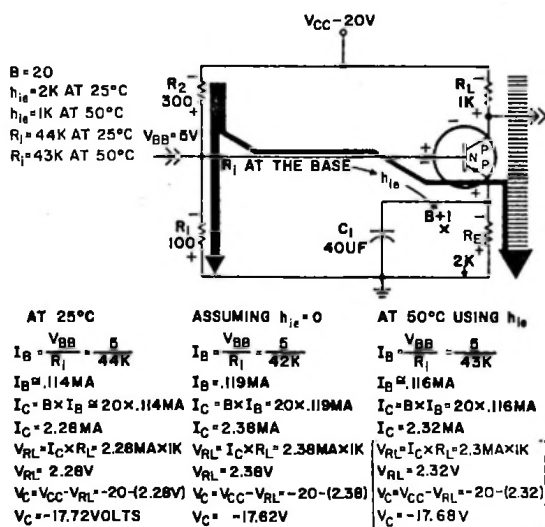

Figure 3-31

An emitter swamping resistor can only minimize the effect of base-emitter resistance changing. A more effective way of temperature stabilizing the base-emitter junction is to cause the voltage at the junction of  $R_1$  and  $R_2$  to decrease at the same rate desired, or in other words, approximately 2 millivolts per degrees centigrade.

### Temperature Stabilization of the Base-Emitter Junction with Thermistors.

Temperature stabilization can be accomplished, as shown in figure 3-32, by replacing  $R_1$  with a thermistor having a negative temperature coefficient. A negative temperature coefficient thermistor will decrease its resistance as temperature increases. The decrease in value of  $R_{T1}$  will decrease the voltage across the base-emitter junction, and if the right value of thermistor is chosen, the voltage can be caused to decrease at the same rate that the base-emitter resistance,  $h_{ie}$ , decreases over a limited range of operation.

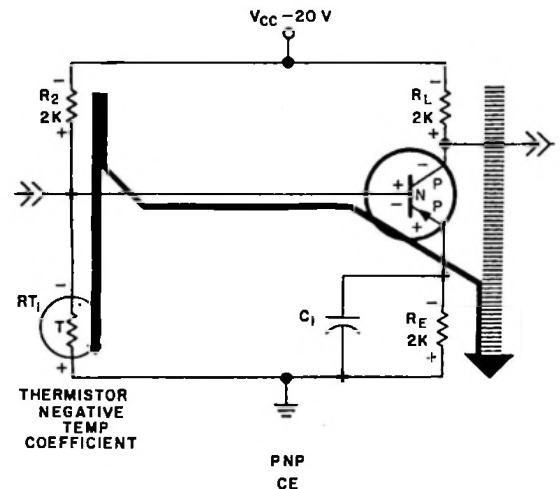

Figure 3-32

Another method, shown in figure 3-33, is to replace  $R_2$  with a positive temperature coefficient thermistor. A positive temperature coefficient thermistor has the property of increasing its resistance as temperature increases. An increase in resistance of  $R_{T2}$  will cause more voltage drop across  $R_{T2}$ , less across  $R_1$ , decreasing  $V_{BE}$  again.

A positive temperature thermistor also could be used in the emitter circuit as shown in figure 3-34.

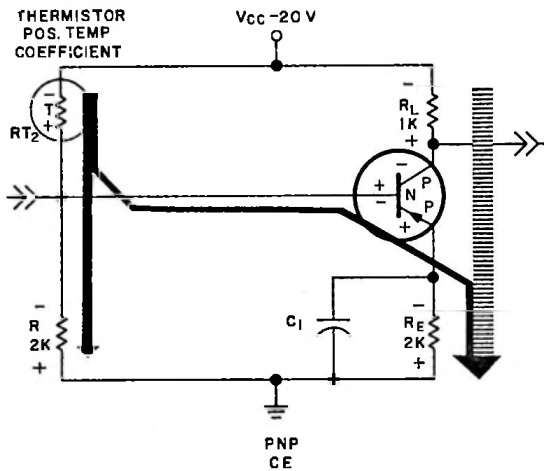

Figure 3-33

If  $R_E$  is replaced with a positive temperature coefficient thermistor, the total resistance from base to ground will remain constant if the thermistor increases its resistance by the same amount that the base emitter decreases resistance, thereby maintaining the base-emitter current constant.

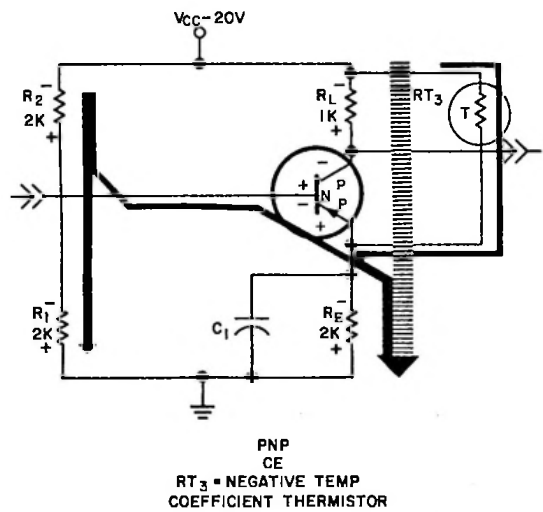

Figure 3-35

Thermistors will only operate over a limited range. If you intend to operate a circuit from 25°C to 50°C, it is very probable that you can obtain a thermistor which will track the base-emitter resistance change over this range.

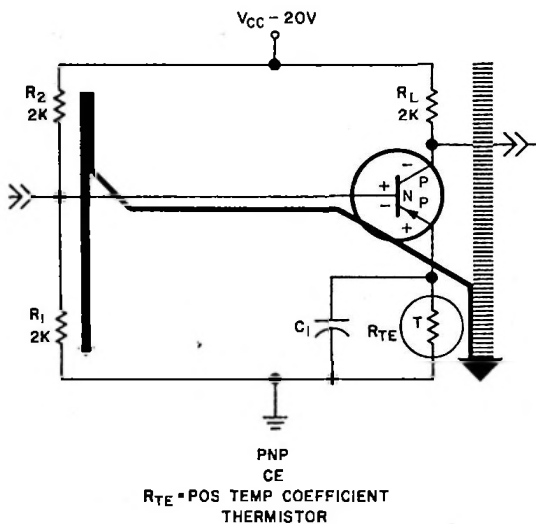

Figure 3-34

Figure 3-35 shows another method of using a negative temperature coefficient thermistor.  $R_{T3}$  is tied between  $V_{CC}$  and the emitter. As temperature increases, the voltage on the emitter will increase due to the decrease in resistance of  $R_{T3}$ . This will cause the voltage across the base emitter,  $V_{BE}$ , to decrease.

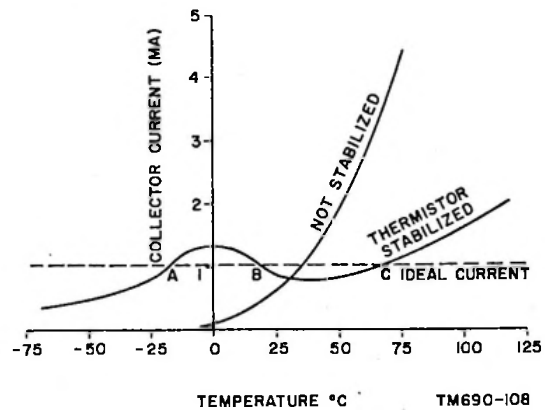

Figure 3-36

Figure 36, shows two curves. One curve is a plot of the collector current versus temperature variations with no stabilization. The other curve is a plot of collector current variations with the circuit thermistor stabilized. Note the thermistor provides a large improvement over no stabilization, and it is also an

improvement over the emitter swamping resistor. Also notice the thermistor does not track the temperature variations of the base-emitter junction exactly. This is apparent because the curve of the thermistor-stabilized circuit varies above and below the ideal current. Note also that the stabilization is only good for approximately minus 25°C to plus 75°C. Below a minus 25°C the collector current decreases rather rapidly. Also, above 75°C the thermistor-stabilized circuit has an increase in collector current that is not returning to the ideal current line. It is apparent then that thermistor stabilization, though an improvement over emitter swamping stabilization, is not the best in temperature stabilization of the base-emitter junction.

### Temperature Stabilization of the Base-Emitter Junction with Diodes.

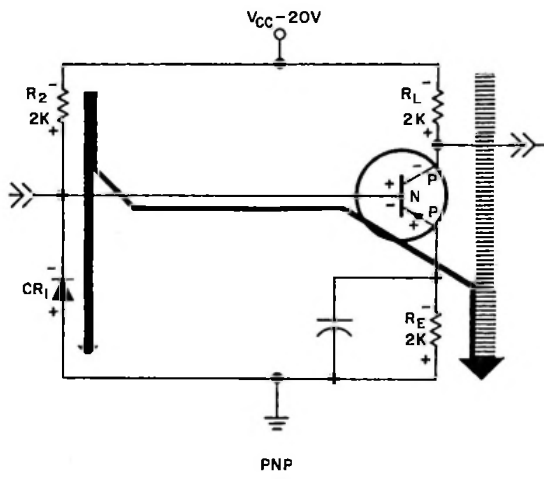

Figure 3-37

A thermistor, as used in place of  $R_1$ , is nothing more than a negative temperature coefficient device. The base-emitter junction is a negative temperature coefficient device which is simply a forward-biased diode.

In figure 3-37  $R_1$  has been replaced with a forward-biased diode. The base-emitter junction of the transistor is a forward-biased diode, and it has a negative temperature coefficient. If a diode can be found which has the same characteristics as the base-emitter junction, the same temperature coefficient will be present on both devices. As the temperature increases, the diode replacing  $R_1$  will decrease its resistance at the same rate that the resistance of the base-emitter junction decreases, thereby decreasing the voltage at the correct rate over the entire range of operation.

It is possible, therefore, to temperature stabilize the base-emitter junction of a transistor by placing in the emitter an emitter swamping resistor that has a value, when multiplied times beta plus 1, greater than 10 times the resistance from base to emitter; by causing  $R_2$  to be a very large resistor and  $R_1$  to be 10 times the input resistance of the transistor; by using either negative temperature thermistors in place of  $R_1$  or  $R_3$  or positive temperature thermistors in place of  $R_2$  or  $R_E$ ; or by substituting a forward-biased diode in place of  $R_1$ .

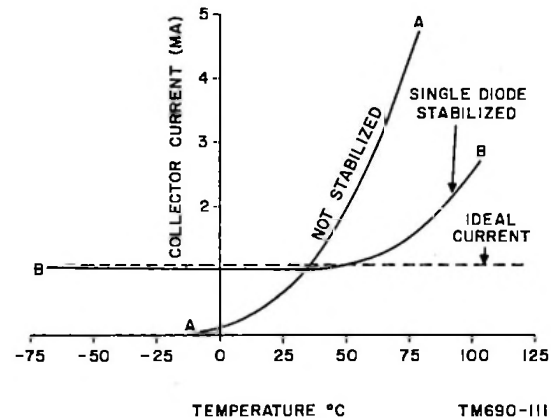

Figure 3-38

Figure 3-38 shows that diode stabilization of the base-emitter junction is by far the best. Notice that by using the single diode for stabilization, the collector current is almost exactly constant from below a minus 75°C to approximately plus 50°C. If this graph was extended to absolute zero, you would find that the collector current would be constant with the single diode stabilization down to approximately a plus 20 degree absolute. Zero degree absolute is 450 degrees below zero centigrade. This indicates that the single diode stabilization is very good at any temperature below plus 50°C. The reason that the single diode does not stabilize the collector current after approximately 50°C will be discussed in the next tape-slide presentation.

Some of you might be wondering how you can apply the material that is being presented in this course to your daily work, as it is rather impractical to open a transistor manual and find the specifications of every transistor in the circuit on which you might be working. By the time that you look up the specifications for these transistors and make the

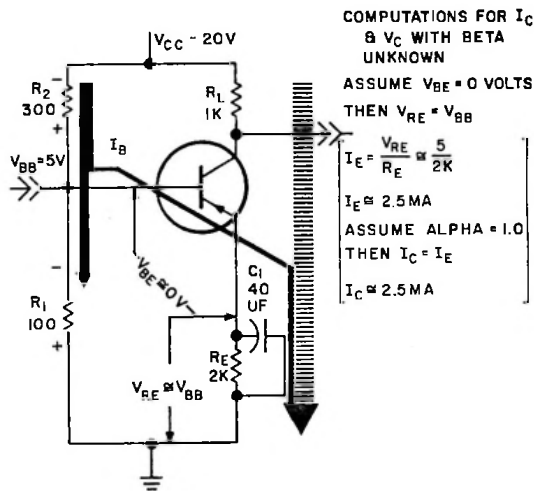

Figure 3-39

computations for the quiescent and operating parameters of the circuit, someone else will have fixed the malfunction in the circuit. The answer to this is that there are many shortcuts that can be used which will provide the information necessary to locate a malfunction in a shorter period of time. Shortcuts for finding the operating parameters,  $A_V$ ,  $A_P$ , and  $R_i$  of any circuit were shown in sections 2 and 3 of the tape-slide presentation. Additional shortcuts for finding the quiescent circuit parameters, such as  $I_B$ ,  $I_C$ , and  $V_C$ , have been shown throughout this section of the tape-slide presentation. Another shortcut is shown in figure 3-39. In figure 3-39, the computations for the approximate values of  $I_C$  and  $V_C$  are shown for a circuit where neither beta or  $h_{ie}$  are known for the transistor. This method is quite practical for actual circuit work. First the voltage of the base supply,  $V_{BB}$ , can be computed roughly by rounding off the values of  $R_2$  and  $R_1$ . In this case no rounding off is necessary, and  $V_{BB}$  is equal to 5 volts. Because the base emitter is nothing more than a forward-biased diode, and never has a very large voltage drop across it, the voltage from the base to the emitter,  $V_{BE}$ , can be assumed to be approximately equal to zero volt. If the voltage drop across the base-emitter is equal to zero volt, then the voltage drop across the emitter resistance,  $R_E$ , is equal to  $V_{BB}$ . Once the voltage dropped across the emitter resistance,  $R_E$ , is known, the value for the emitter current,  $I_E$ , can be found by dividing the voltage drop across the emitter resistance,  $V_{RE}$ , by the value of the emitter resistance. In this case  $I_E$  would be approximately equal to 5 divided by 2K. Therefore,  $I_E$  is approximately equal to 2.5 milliamperes. Alpha is usually a value between 0.92 and 0.999, so for approximations, alpha may be assumed to be equal to 1. If alpha equals 1, then  $I_C$  equals  $I_E$ , and  $I_C$  is approximately equal to 2.5 milliamperes. This is true because alpha is the ratio of collector current to

emitter current, and alpha times  $I_E$  equals  $I_C$ . The value obtained for  $I_C$  will be slightly higher than it actually is due to the assumption that  $V_{BE}$  is equal to zero and that alpha equals 1.

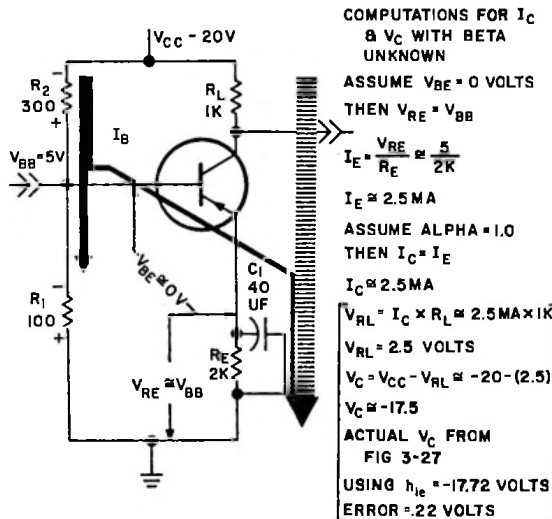

Figure 3-40

Examine figure 3-40 to see how much effect the error in  $I_C$  will have upon the collector voltage,  $V_C$ . The voltage drop across  $V_{RL}$  can be computed by multiplying  $I_C$  times  $R_L$ . Therefore,  $V_{RL}$  is approximately equal to 2.5 milliamperes times 1K, or 2.5 volts. Subtracting this voltage from the collector supply,  $V_{CC}$ , of a minus 20 volts will give  $V_C$ , the collector voltage. 2.5 volts subtracted from a minus 20 volts leaves a value for  $V_C$  of approximately a minus 17.5 volts. Now the actual voltage on the collector,  $V_C$ , as obtained from figure 3-27 where a beta of 20 was used along with the value of  $h_{ie}$ , is a minus 17.72 volts. The total error involved between using the values of beta and  $h_{ie}$  and the method shown here is 0.22 volt. This assuredly is close enough in actual circuit work to tell whether the transistor is operating properly.

If you will force yourself to apply these approximate equations in your actual work for a short period of time, you will soon find that you are doing this automatically and that it is saving you time.

### Review.

Review the material covered during this portion of the transistor course. The first circuit that was examined is shown in figure 3-41. It stated that if the parallel value of  $R_1$  and  $R_2$  was small compared to the value of the resistance from the base to the emitter, then the voltage at the junction of  $R_1$  and  $R_2$  was not dependent



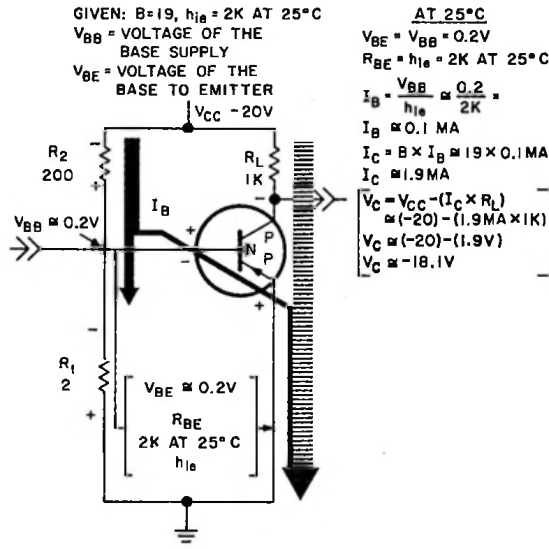

Figure 3-41

upon the transistor and could be found by assuming that the base lead was open. The voltage at the junction of  $R_1$  and  $R_2$  is called  $V_{BB}$  and is the voltage of the base supply. The method for determining the quiescent  $I_B$ ,  $I_C$ , and  $V_C$  was shown, and  $V_C$ , the voltage at the collector, was found to be approximately equal to minus 18.1 volts at  $25^\circ C$ .

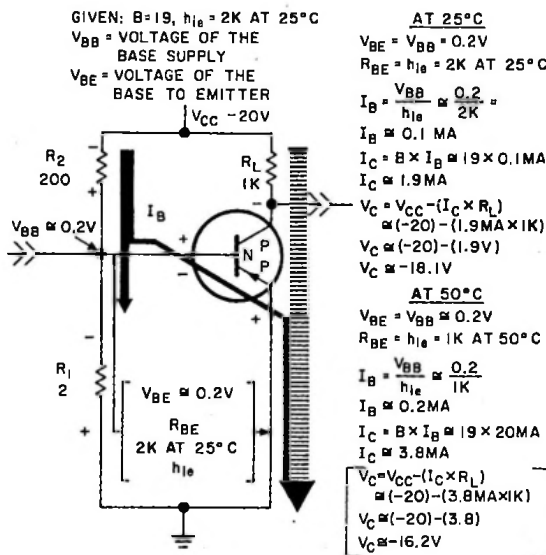
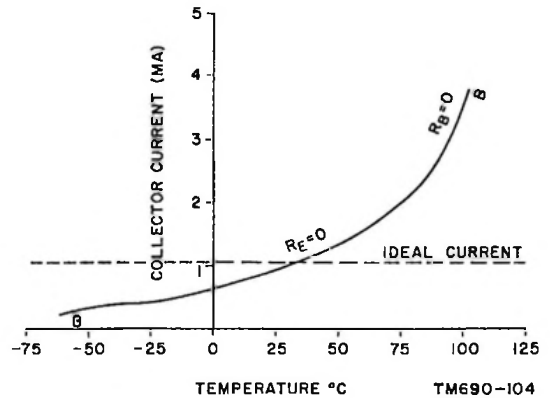

Figure 3-42

The quiescent operating voltages and currents were again computed at a temperature of  $50^\circ C$ , where  $h_{ie}$  was equal to  $1K$  as shown in figure 3-42. It was found that with this bias arrangement,  $I_B$  increased from 0.1 milliamperes to 0.2 milliamperes. The increase in

$I_B$  caused the collector current,  $I_C$ , to increase as a function of beta to approximately 3.8 milliamperes. This increase in the collector current caused a decrease in the collector voltage,  $V_C$ , to approximately a minus 16.2 volts. This represented approximately a 2-volt change in the collector voltage for a  $25^\circ C$  change in the operating temperature.



The fact that this is an undesirable effect of the transistor, that must be compensated for, is shown by the curve shown in figure 3-43. As can be seen, with  $R_E$  equal to zero and the base resistance,  $R_B$ , which equals the parallel values of  $R_1$  and  $R_2$  equal to approximately zero, the collector current changes by a large amount for a given change in temperature.

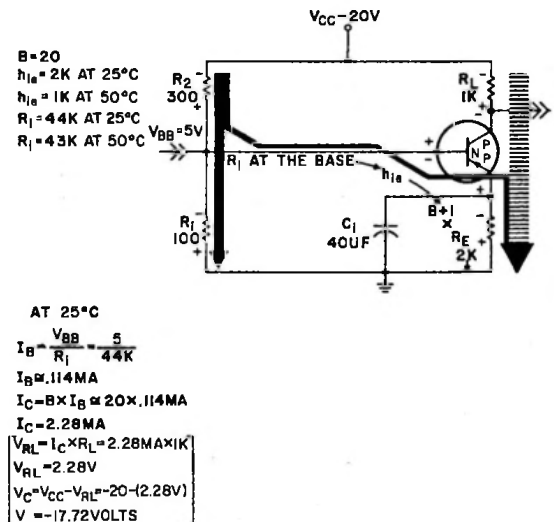

Figure 3-44

CHAPTER 3  
Bias Stabilization

It was found that increasing the value of  $R_2$  or  $R_E$ , as shown in figure 3-44, would increase the total resistance in series with the base current,  $I_B$ . Computations for the quiescent currents and voltages of this circuit were shown at 25°C; it was found that with a value of 2K for  $h_{ie}$ ,  $V_C$  was equal to minus 17.72 volts.

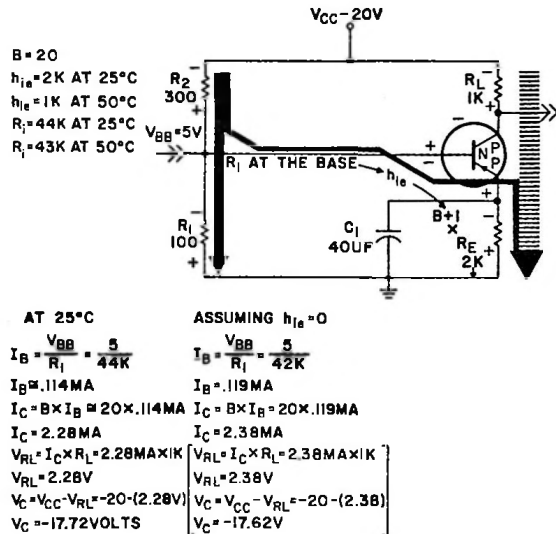

Figure 3-45

The quiescent operating currents and voltages were then refigured assuming a worst case condition, as shown in figure 3-45, where  $h_{ib}$  was equal to zero. Under these conditions it was found that there was a very slight change in the base current and collector current, and the collector voltage was found to be equal to a minus 17.62 volts. This represented a change in the collector voltage of 0.1 volt under worst case conditions.

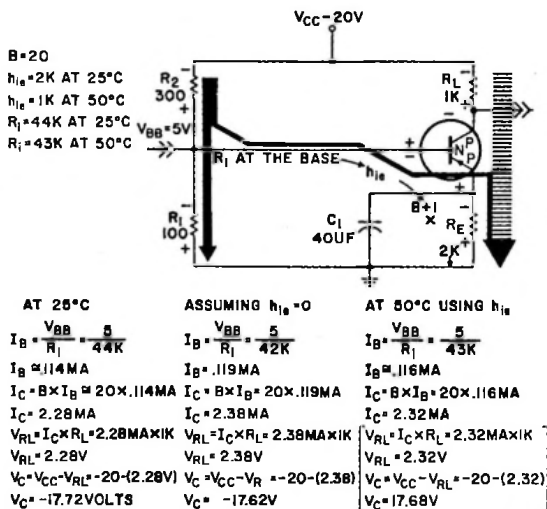

Figure 3-46

A more realistic value of 1K was then used for  $h_{ie}$ , and the quiescent currents and voltages were then computed for 50°C. The change in  $I_B$  from the 25°C figure was found to be very slight. This change was also apparent in  $I_C$ , but again it was only by a very small amount. The change in  $I_C$  caused a change in  $V_C$ , but this change also was very slight. The value for  $V_C$  at 50°C was found to be equal to a minus 17.68 volts. This represented a change of 0.04 volt in the collector voltage for a change of 25°C.

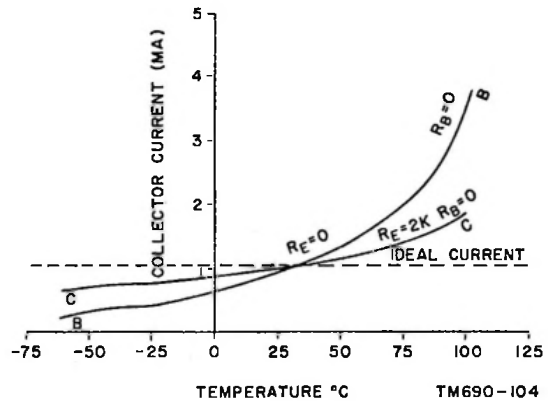

Figure 3-47

Figure 3-47 shows that increasing the value of  $R_E$  to 2K ohms and maintaining a low value of base resistance will cause the collector current to be much closer to the ideal current than if the resistance of the emitter is zero, and the resistance of the base is also zero or low. It can be seen, though, that this is not the final answer to the bias stabilization problem, as the collector current still varies as a function of temperature.

It was explained that the bias stabilization problem could be somewhat rectified by substituting a thermistor with a negative temperature coefficient for  $R_1$ , as shown in figure 3-48. When a negative temperature coefficient thermistor is used as  $RT_1$ , it will cause the voltage at the base of the transistor to decrease as the temperature increases.

A positive temperature coefficient thermistor could be used in place of  $R_2$  as shown in figure 3-49. A positive temperature coefficient thermistor

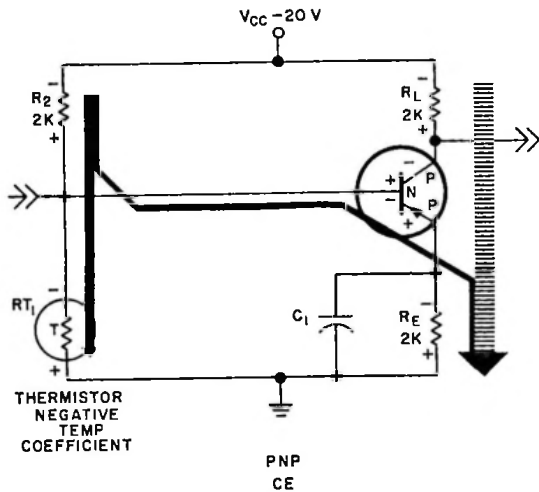

Figure 3-48

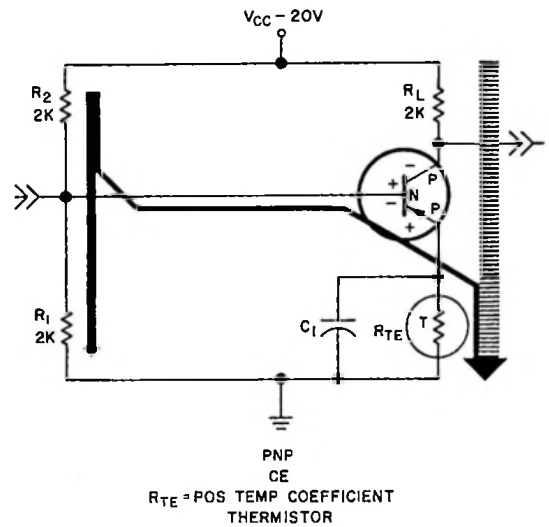

Figure 3-50

substituted for  $R_2$  will provide the same function as a negative temperature coefficient thermistor substituted for  $R_1$ .

A negative temperature coefficient thermistor,  $RT_3$ , also can be used to temperature stabilize a transistor as shown in figure 3-51. As the temperature increases, the resistance of  $RT_3$  will decrease, causing the voltage at the emitter of the transistor to go toward the base potential. This in effect decreases  $V_{BE}$ , and if the correct value of  $RT_3$  is chosen, the decrease in voltage, from base to emitter, will be at a rate of 2 millivolts per degrees centigrade.

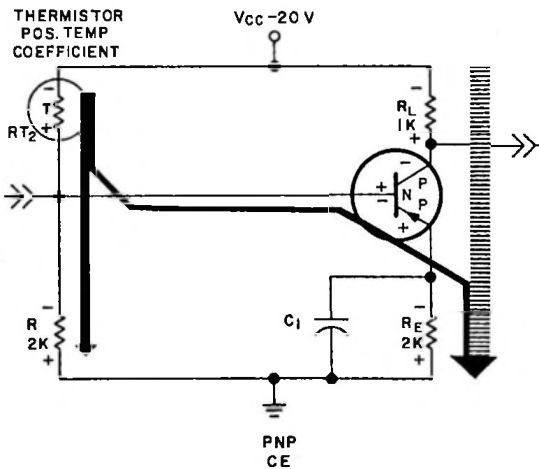

Figure 3-49

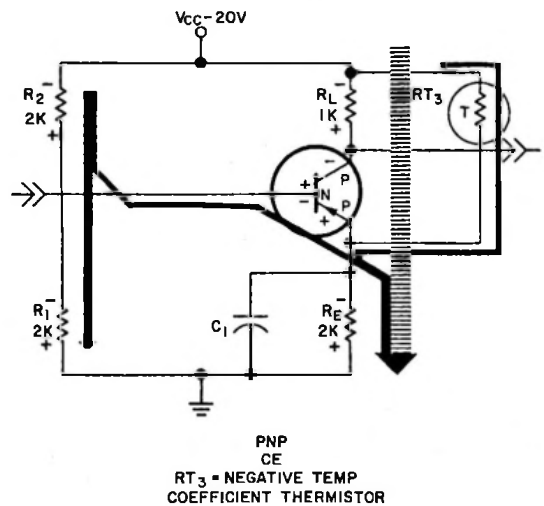

Figure 3-51

Figure 3-50 shows that a positive temperature coefficient thermistor can also be used in place of  $R_E$ . Used as shown it will increase its resistance, ideally, at the same rate that  $h_{ie}$  decreases.

Figure 3-52 shows the curves of a circuit that is not stabilized and also of one that is thermistor stabilized. Although the thermistor-stabilized circuit comes closer to the ideal current, it can be seen that

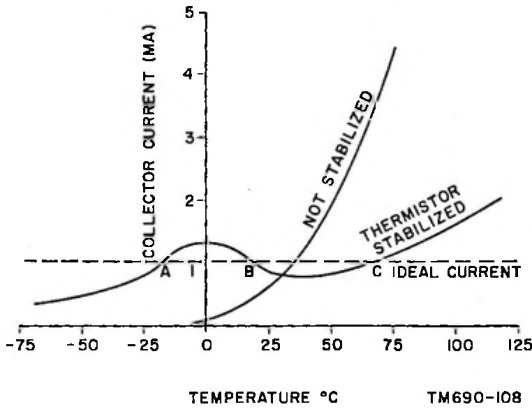

Figure 3-52

the thermistor-stabilized circuit is still not the final answer for extremely good stabilization. The reason for this is that the temperature curve of the thermistor can not be matched to the temperature curve of the transistor; therefore, it does not accurately track the change in the resistance from base to emitter. This causes the collector current to vary above and below the ideal current as temperature is increased.

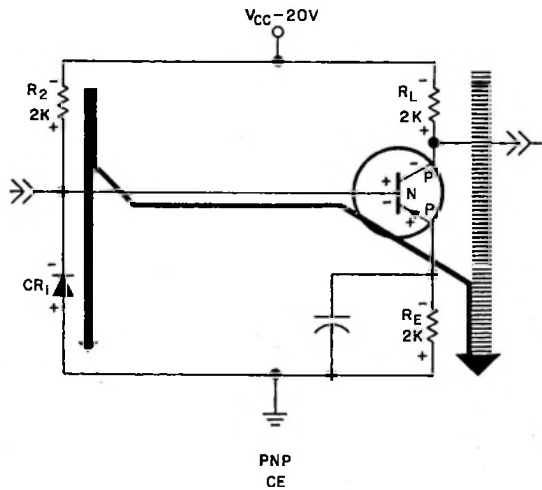

Figure 3-53

As you well know the base-emitter junction of a transistor has a negative temperature coefficient and is nothing more than a forward-biased diode. As shown in figure 3-53, a forward-biased diode may be substituted for  $R_1$  to provide bias stabilization of the circuit. If the temperature coefficient of the diode used for compensating the transistor and the temperature coefficient of the transistor are matched, the transistor is well stabilized from a plus 50°C down to almost absolute zero. This apparently is the method that must be used if temperature stabilization of the transistor is critical.

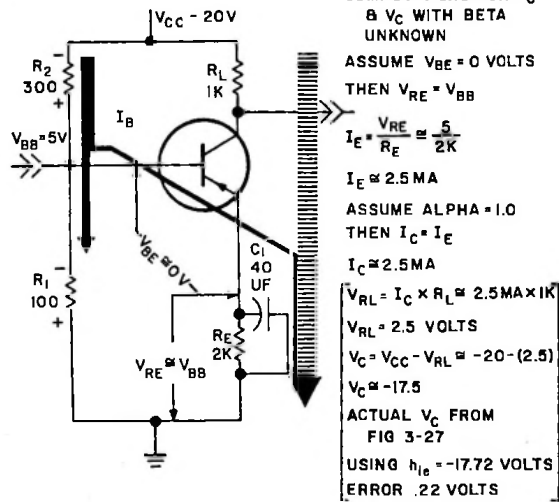

Figure 3-54

It was also shown, as in figure 3-54, that there are many shortcuts that can be used to approximate the quiescent and operating parameters of the transistor circuit. You are urged to use these shortcuts to find the approximate values in the actual circuits on which you are working.

### Section 4 Work Problems

Some of the following problems are arranged so that you may conveniently underscore the correct word, or fill in the blanks, or answer thought questions in your own words. Disregard the value of  $R_1$  for all computations of input resistance.

1. For good bias stabilization, it is desirable to maintain the value of  $R_1$  and  $R_2$  low and maintain  $R_e = 0$ . (True or False)
2. The best method of stabilizing the base-emitter junction of a transistor is to use a \_\_\_\_\_ in place of  $R_1$ .
3. The voltage drop across  $R_L$  is known as  $V_C$ . (True or False)
4. The base-emitter junction displays a \_\_\_\_\_ temperature characteristic.
5. The value of  $h_{ie}$  (may or may not) be disregarded in approximating the value of the quiescent  $I_B$  when  $R_E = 0$  and  $R_1 = 10 \times h_{ie}$ .
6. The value of  $R_E$  (may or may not) be disregarded in approximating the value of the quiescent  $I_B$  when  $h_{ie} = 5K$ ,  $\beta = 40$ ,  $R_E = 500$  ohms, and  $V_{BB}$  is constant.
7. A thermistor that displays a negative temperature coefficient will (increase or decrease) in resistance as the temperature decreases.
8. What coefficient of thermistor would be necessary to replace  $R_2$  to obtain bias stabilization? (Positive or Negative)
9. What would be the quiescent collector voltage,  $V_C$ , of figure 3-27 at  $25^\circ C$  if  $R_L$  was increased to 5K and all other values remained the same?
10. The capacitor,  $C_1$ , bypassing  $R_E$ , in figure 3-27, provides what function?
11. When a resistor is placed in the emitter of a transistor for the sole purpose of providing temperature stabilization, it is called an \_\_\_\_\_ resistor.
12. Substituting the values given here for those in figure 3-9, find  $V_{BE}$ ,  $I_C$ , and  $V_C$  at  $25^\circ C$ . (Show your work.)

$$\begin{aligned} V_{CC} &= -30 \text{ volts} \\ R_1 &= 10 \text{ ohms} \\ R_2 &= 740 \text{ ohms} \end{aligned}$$

$$\begin{aligned} h_{ie} &= 2K \text{ at } 25^\circ C \\ \beta &= 25 \\ R_L &= 2K \end{aligned}$$

A. Find  $V_{BE}$

B. Find  $I_C$

C. Find  $V_C$

13. Using the values in problem 12, find  $V_{BE}$ ,  $I_C$ , and  $V_C$  at  $50^\circ C$  if  $h_{ie}$  equals 1K1 at  $50^\circ C$ . (Show your work.)

CHAPTER 3  
Bias Stabilization

A. Find  $V_{BE}$

B. Find  $I_C$

C. Find  $V_C$

14. Substituting the values given here for those in figure 3-40 and using the method of approximating, find  $V_{RE}$ ,  $I_C$ , and  $V_C$  (beta and  $h_{ie}$  unknown).

$$\begin{aligned}V_{CC} &= 24 \text{ volts} \\R_1 &= 2.3\text{K} \\R_2 &= 5.8\text{K}\end{aligned}$$

$$\begin{aligned}R_E &= 2\text{K} \\R_L &= 1.5\text{K}\end{aligned}$$

A. Find  $V_{RE}$

B. Find  $I_C$

C. Find  $V_C$

As soon as you have answered the above questions to the best of your ability, you are ready to proceed to section 5 of the tape-slide presentation, where the work problems will be reviewed and the correct answers given.

**Introduction.**

This is the fifth and last section of the tape-slide presentation. This portion of the tape-slide presentation consists of a detailed discussion of bias stabilization of the base-collector junction, a discussion of the different stability factors, a discussion on different types of biasing, and a discussion on how to interpret the values found in a transistor manual.

In the first half of chapter 3, the bias stabilization of the base-emitter junction was discussed, but there has been no discussion of bias stabilization of the base-collector junction.

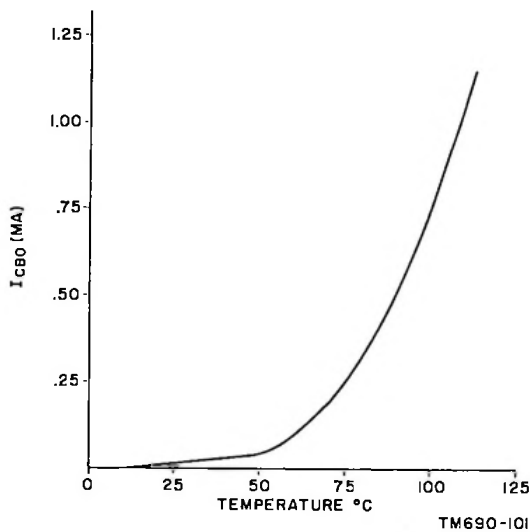

Figure 3-55

Figure 3-55 shows the plot of the reverse current,  $I_{CBO}$ , at different temperatures in degrees centigrade.

Notice that the increase in  $I_{CBO}$  is very slight until approximately 50°C. At this point,  $I_{CBO}$  begins to increase rather rapidly with any increase in temperature. Therefore,  $I_{CBO}$  becomes a problem in bias stabilization any time that the transistor is to be operated at temperatures greater than 50°C.

**Review of the Effects of  $I_{CBO}$ .**

Let us review the material that has been presented previously concerning  $I_{CBO}$ . As shown in figure 3-56,  $I_{CBO}$  can only be measured with the emitter lead open, or with the base lead open. This current, called  $I_{CBO}$ , is the leakage current of a back-biased diode.

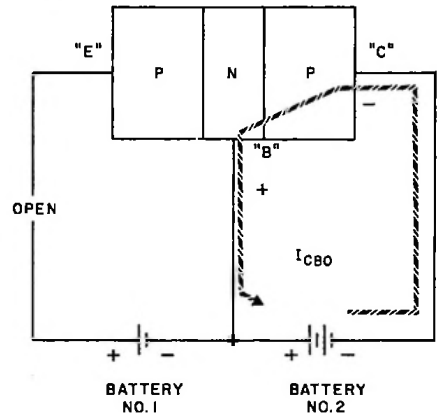

Figure 3-56

As shown in figure 3-57, when the transistor is connected properly, with the base emitter forward biased and the base collector backed biased,  $I_{CBO}$  tries to flow in the opposite direction of  $I_B$ . But as we well know it is impossible for current to flow in two directions at the same time through the same wire.

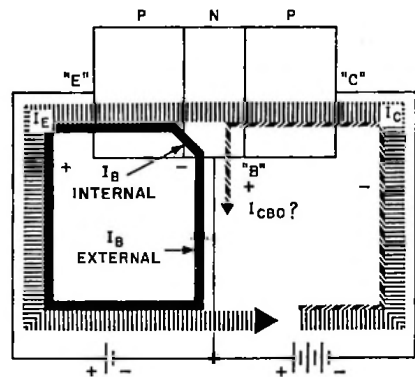

Figure 3-57

Actually,  $I_{CBO}$ , though opposing the external  $I_B$ , adds on to the internal  $I_B$ . The internal  $I_B$  is the combination of  $I_{CBO}$  and a portion of the  $I_B$ . Stated another way, the internal  $I_B$  is equal to the external  $I_B$  and  $I_{CBO}$ .

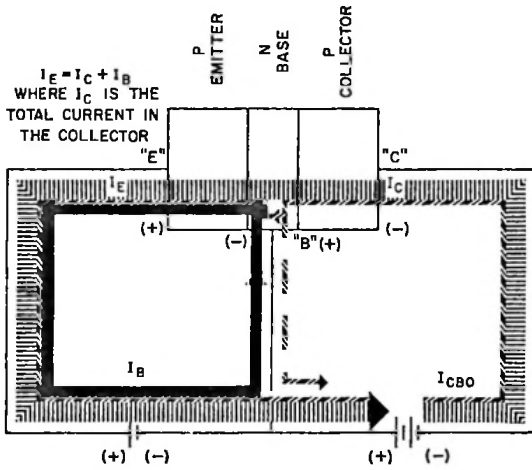

Figure 3-58

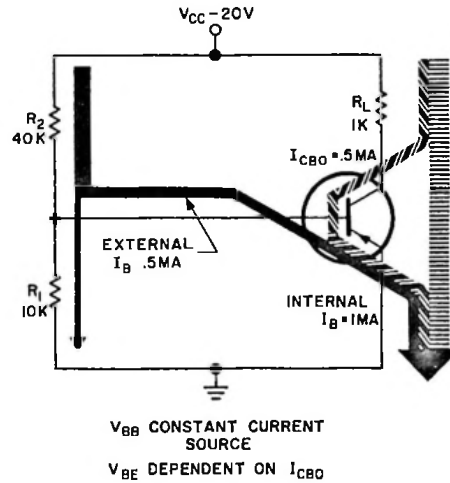

Figure 3-60

If the values of  $R_1$  and  $R_2$  are made very large, as in figure 3-59, then the external  $I_B$  becomes a relatively constant current. If this external  $I_B$  is equal to 0.5 milliamperes and  $I_{CBO}$  is equal to 0.1 milliamperes, then the internal  $I_B$  will be equal to 0.6 milliamperes as shown in figure 3-59. Remember, the internal  $I_B$  is equal to the external  $I_B$  plus  $I_{CBO}$ .

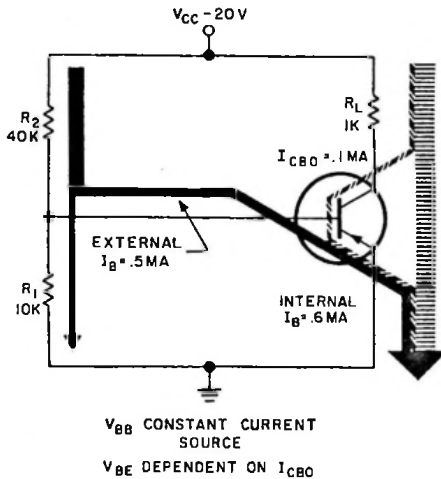

Figure 3-59

If the temperature of the transistor in this circuit were to be increased to some temperature greater than  $50^\circ C$ , the value of  $I_{CBO}$  would increase appreciably as shown in figure 3-60. If the external base current does not decrease with this increase in temperature,

then the internal base current is going to increase as a function of an increase in  $I_{CBO}$ . This increase in  $I_{CBO}$  is equal to 0.4 milliamperes. Therefore, the internal  $I_B$  will increase by 0.4 milliamperes as shown. During a previous discussion of bias stabilization of the base-emitter junction, it was found that any change in  $I_B$  will result in a large change in the collector current. Remember, for good stability of the base-emitter junction, the base-emitter voltage must decrease at a rate of approximately 2 millivolts per degrees centigrade of increase in temperature. As  $I_{CBO}$  begins to increase, it causes a greater current to flow through  $h_{ie}$ . This increasing current through  $h_{ie}$  is going to increase the voltage drop across  $h_{ie}$ . Therefore, the voltage from base to emitter,  $V_{BE}$ , becomes dependent upon  $I_{CBO}$  whenever a circuit is biased as shown here. This effect would be extremely appreciable at junction temperatures greater than  $50^\circ C$  where  $I_{CBO}$  begins to increase rather rapidly.

#### Temperature Stabilization of the Base-Collector Junction with Resistors.

This problem could be corrected, as shown in figure 3-61, by decreasing the values of  $R_1$  and  $R_2$  to such an extent that the voltage at the base becomes dependent upon the value of  $R_1$  and  $R_2$  rather than the transistor. In figure 3-61, the external  $I_B$  is equal to 0.4 milliamperes, while the internal  $I_B$  is equal to 0.5 milliamperes due to an  $I_{CBO}$  of 0.1 milliamperes. The resultant of the external base current and the collector leakage current is called the internal base current and flows through the resistance called  $h_{ie}$ .



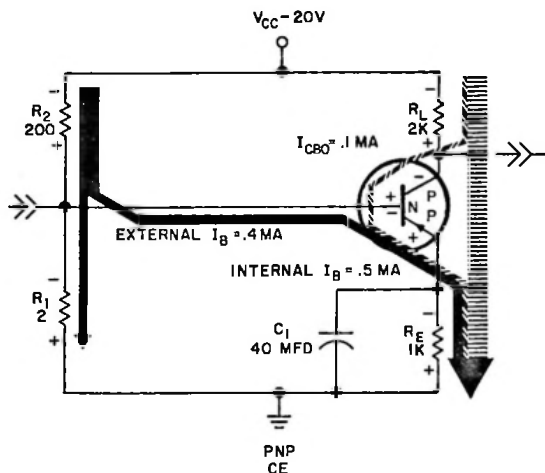

Figure 3-61

If the temperature of the junction should increase, then the value of  $I_{CBO}$  will also increase as shown in figure 3-62; but, with this method of biasing, the voltage across the base-emitter junction is not dependent upon the transistor, but rather upon the values of  $R_1$  and  $R_2$ . This means that, if the value of  $I_{CBO}$  would be increased to 0.5 milliampere, as shown in figure 3-62, there would be no external base current. This is true because the internal base current, which is now equal to  $I_{CBO}$ , is flowing through the resistance of  $h_{ie}$ . This will develop a voltage across the base-emitter junction. If the voltage developed by  $I_{CBO}$  across the base-emitter junction is equal to the voltage at the junction of  $R_1$  and  $R_2$ , there will be

no external base current. The voltage from the base to the emitter,  $V_{BE}$ , is not dependent upon the value of  $I_{CBO}$ , because as  $I_{CBO}$  increased, the external base current decreased, maintaining the voltage from the base to the emitter at a constant potential. If  $I_{CBO}$  were to increase to a value greater than 0.5 milliampere, then it would try to develop a voltage across the base-emitter junction greater than the voltage found at the junction of  $R_1$  and  $R_2$ . When this occurs, a certain portion of  $I_{CBO}$  will flow from the base, to the junction of  $R_1$  and  $R_2$ , in the opposite direction of normal base current. The voltage from base to emitter at this time would still be approximately equal to the original  $V_{BE}$  and not dependent upon  $I_{CBO}$ .

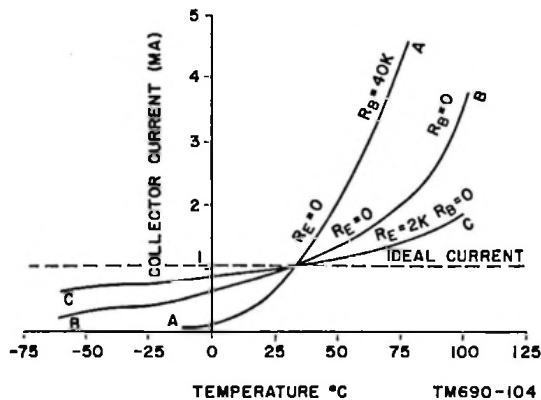

Figure 3-63

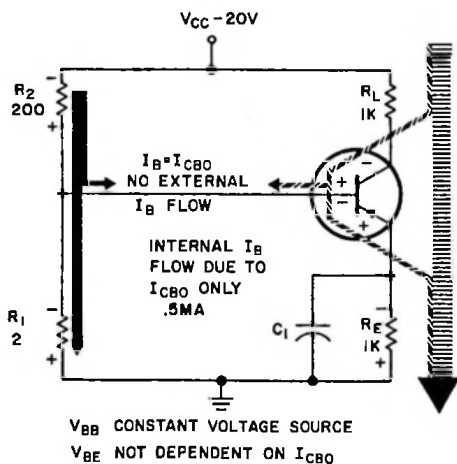

Figure 3-62

It is apparent then that for good bias stability of both the base-emitter junction and the base-collector junction, the value of  $R_E$  should be made large, and the value of  $R_1$  and  $R_2$  should be made as small as possible as shown in curve "C" of figure 3-63. If the value of  $R_E$  is made small and the value of  $R_1$  and  $R_2$  is large, the circuit will be very unstable as shown in curve "A" of figure 3-63. It is not desirable to keep the value of both  $R_E$  and  $R_B$  low as shown in curve "B" of figure 3-63.

For good stabilization of the entire circuit, including  $I_{CBO}$  and the base-emitter resistance,  $V_{BE}$ , it is desirable to keep the value of  $R_1$  and  $R_2$  small and the value of  $R_E$  large. Stated another way, it is beneficial to keep the base resistance low and the emitter resistance high for good bias stabilization.

Temperature Stabilization of the Base-Collector Junction with Diodes.

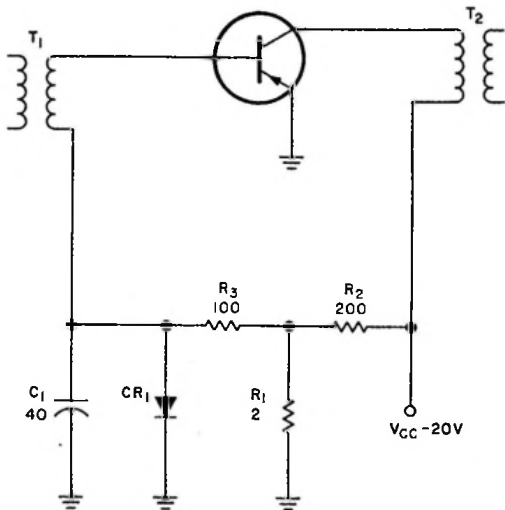

Figure 3-64

Another method of compensating for the effect of  $I_{CBO}$  is shown in figure 3-64. You will notice that we are again using a PNP type transistor, but that transformer coupling is used in the input and output.  $T_1$  functions as the input load, while  $T_2$  functions as the output load. The same type of biasing exists, with the voltage dividing network,  $R_1$  and  $R_2$ , providing bias to the transistor.

Examine figure 3-65 to see if the correct bias polarity exists. Using the rule to determine the correct biasing, first determine the type of transistor, which in this case, is a PNP. The arrow is pointing toward the base. Then write the letters "P-N-P", as in figure 3-65, on the back side of the transistor symbol.

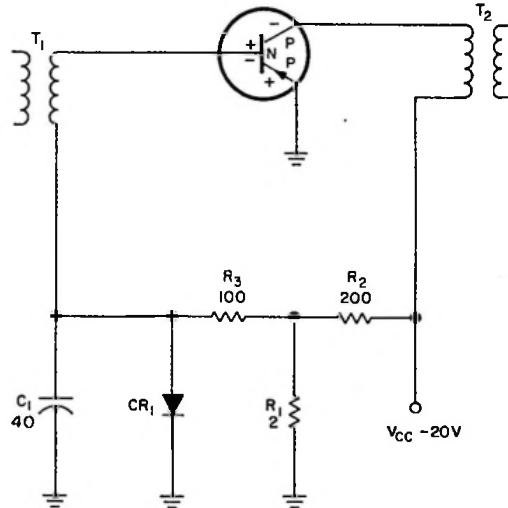

Figure 3-66

Now starting at the emitter, match the polarity of the emitter with the polarity of the battery as is shown in figure 3-66. In this case, the emitter being "P" type material, start with a positive. Going toward the collector, go in series, positive, negative, positive, negative, as shown. This is the bias desired for the transistor.

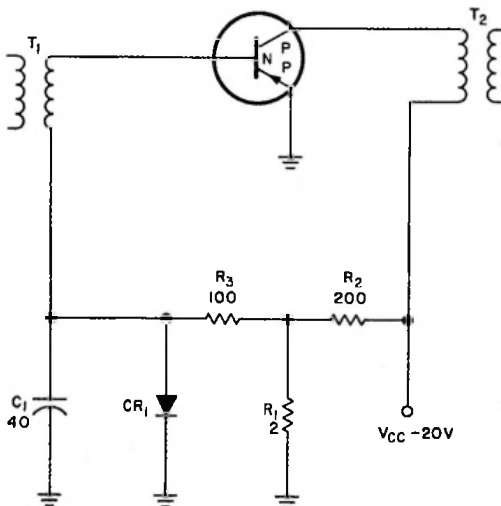

Figure 3-65

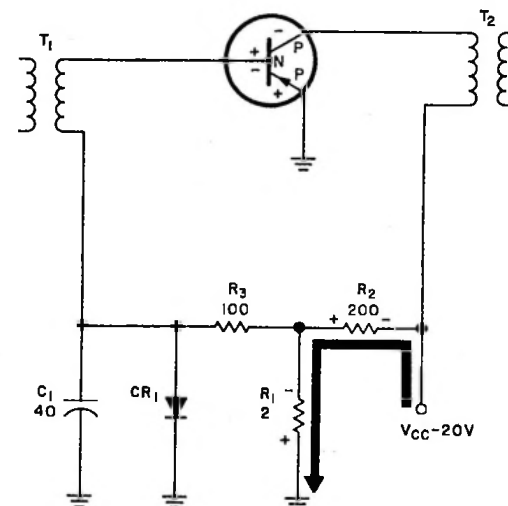

Figure 3-67

Examine figure 3-67 to see if this exists. To find the polarity of the bias across the junctions, for biasing purposes, we can assume that  $R_3$ ,  $T_1$ , and  $T_2$  are zero ohm.  $R_1$  and  $R_2$  make up a voltage-dividing network from B- to ground. Current is flowing from B- through  $R_2$  and  $R_1$  creating the polarities shown.

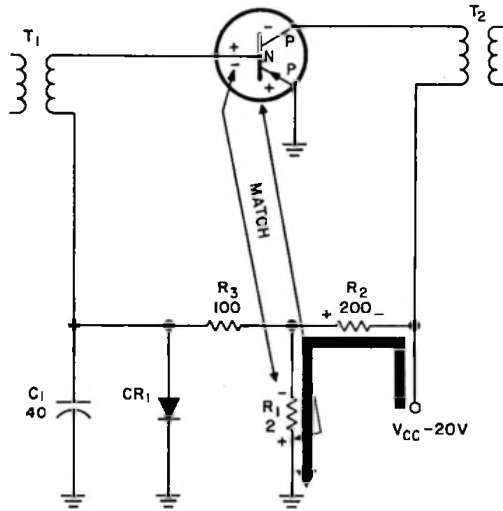

Figure 3-68

This will provide the correct polarity of bias for the base-emitter junction as shown in figure 3-68. The junction of  $R_1$  and  $R_2$  is again attached to the base of the transistor through  $R_3$  and  $T_1$ . So  $R_1$  is in parallel with  $R_3$ ,  $T_1$ , and the base-emitter resistance. The polarity of the voltage across  $R_1$  is negative at the top to positive at the bottom. This will cause the correct polarity to exist across the base emitter.

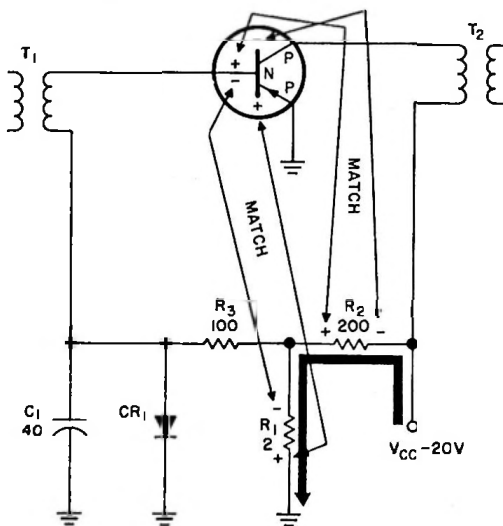

Figure 3-69

At the same time, as indicated in figure 3-69,  $R_2$  is attached from the base to collector and is in parallel with  $R_3$ ,  $T_1$ , and the base-collector resistance and  $T_2$ . Therefore, we have the correct bias polarity across the base-collector junction.

All that is necessary, when  $R_3$  and  $T_1$  are placed in the circuit, is to increase the value of  $R_1$  or decrease the value of  $R_2$  to compensate for the voltage drop across  $R_3$  and  $T_1$  to obtain the correct biasing for the transistor.

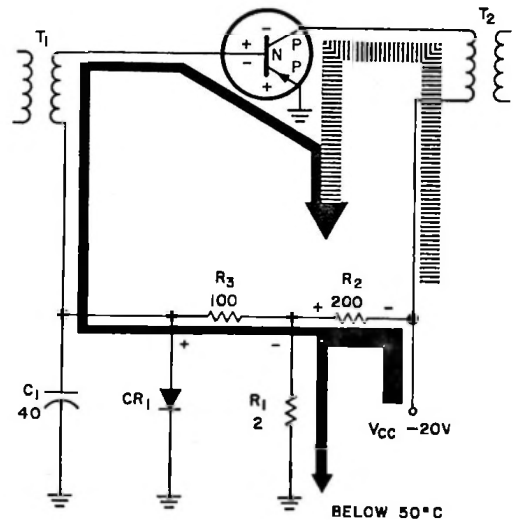

Figure 3-70

Examine figure 3-70 for bias stabilization. Small values are still being used for  $R_2$  and  $R_1$ , 2 ohms for  $R_1$  and 200 ohms for  $R_2$ . Notice that  $CR_1$  is a back-biased diode and is connected to the base.

The base-to-collector junction is also a back-biased diode. Assume that the temperature is at some low value and that a negligible amount of leakage current,  $I_{CBO}$ , is flowing. If the collector-to-base junction, a back-biased diode, is not leaking, then the diode,  $CR_1$ , will not be leaking appreciably and serves no function in the circuit at this time.

As temperature increases to above  $50^\circ\text{C}$ , the base collector starts to leak as shown in figure 3-71. If we can obtain a diode which has approximately the same characteristics, it will conduct an equal amount at about  $50^\circ\text{C}$ . Remember, if the current through the base emitter, externally, remains constant and  $I_{CBO}$  increases, there will be an increase in the total current flowing from the base to the emitter, and  $I_C$  will increase as a function of beta times this increase.

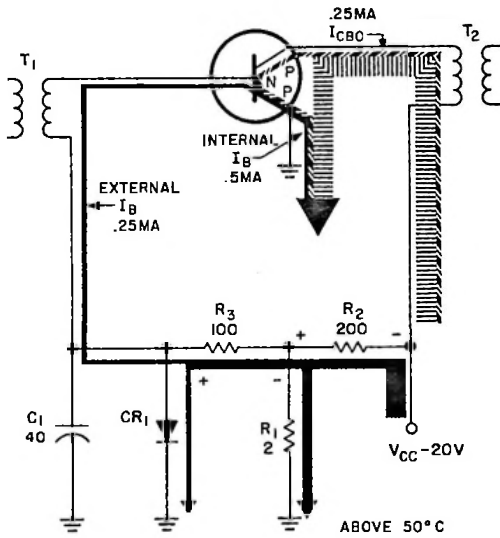

Figure 3-71

In this case, as  $I_{CBO}$  begins to increase,  $CR_1$  begins to leak also, and it will leak off a current which is equal to the current which is being supplied by the collector in the form of  $I_{CBO}$ . The current that flows through  $R_3$  down through  $CR_1$  causes a negative-to-positive voltage drop across  $R_3$  as shown. This causes the base to go more positive, or less negative, decreasing the voltage drop across the base-emitter junction,  $V_{BE}$ , of the transistor and temperature compensating the circuit for  $I_{CBO}$ .

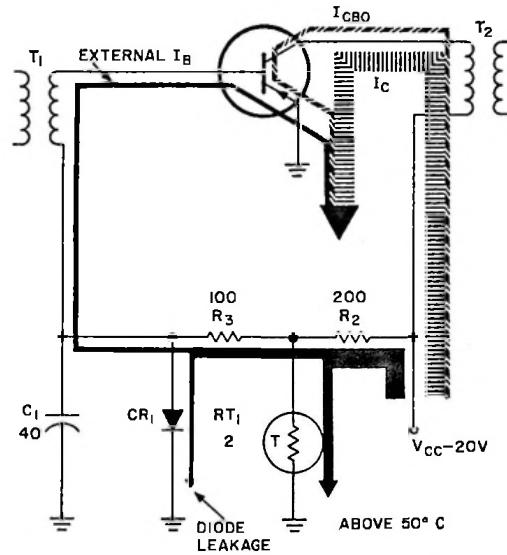

Figure 3-73

During the previous discussion, the bias stability of the base-emitter junction was disregarded. If a thermistor,  $RT_1$ , was used in place of  $R_1$ , as in figure 3-73, and the thermistor had a negative temperature coefficient, then the circuit would be stabilized for both base-emitter resistance changes and base-collector resistance changes.

#### Duodiode Stabilization.

A better method of stabilizing the base-emitter junction along with the base collector junction is shown in figure 3-74. Notice that diode  $CR_2$  is biased in the forward-biased direction, as shown before in the first section of chapter 3. A forward-biased diode has a negative temperature coefficient, and therefore, as the resistance of the base emitter decreases, the resistance of the diode  $CR_2$  will decrease also, decreasing  $V_{BE}$  at a rate of approximately 2 millivolts per degrees centigrade. When the point is reached where  $I_{CBO}$  begins to increase rapidly,  $CR_1$  will also begin to leak, as was found before, compensating the circuit for  $I_{CBO}$ . This is known as duodiode stabilization, and although it is not very commonly used, it does thoroughly compensate for both base-emitter and  $I_{CBO}$  changes.

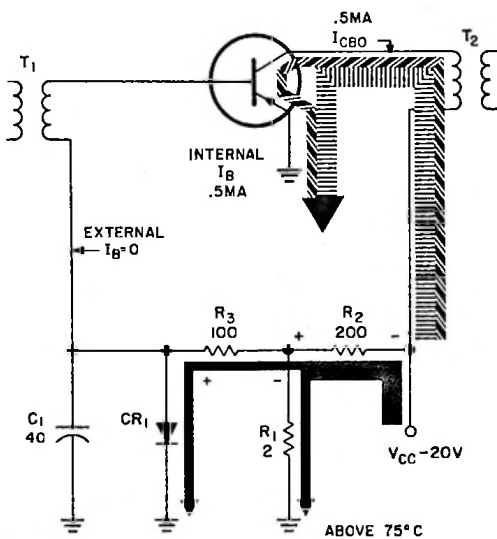

Figure 3-72

If the temperature of the junction would be increased even further, until the value of  $I_{CBO}$  equals the original external base current, there would be no external base

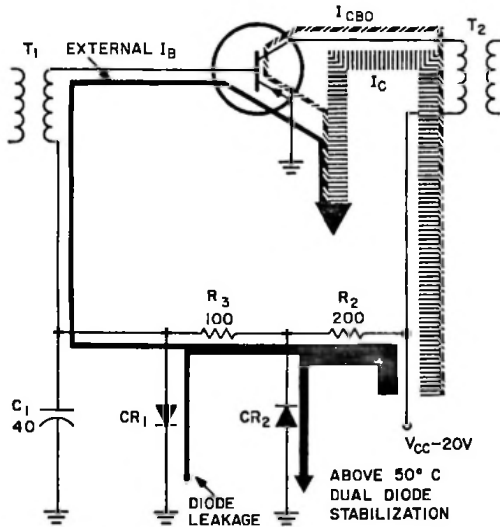

Figure 3-74

As shown in figure 3-75 the duodiode, or double-diode, stabilized circuit is extremely stable over a very wide temperature range, and any circuit utilizing this method of stabilization will have little or no variations in the collector current due to temperature. Curve "B" is the single-diode stabilized circuit discussed in the first section of chapter 3. The single-diode stabilized circuit did not have any compensation for changes in  $I_{CBO}$ ; therefore, the collector current began to increase very sharply at approximately a plus 50°C due to changes in  $I_{CBO}$  at this time. Curve "A" is the curve of a nonstabilized circuit. Notice the double-diode stabilized circuit provides a large improvement over the nonstabilized circuit of curve

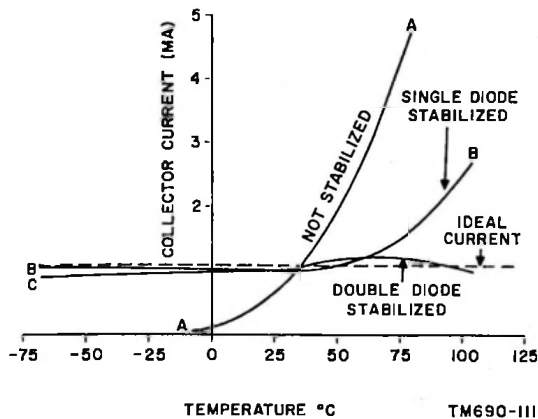

Figure 3-75

"A". Although the double-diode stabilized circuit is very stable over a wide range of temperature, it is seldom used due to the problems and costs involved in matching the biasing diodes to the transistor. The most common method of bias stabilization that you will find in circuits will be an emitter swamping resistor and possibly a thermistor, either positive or negative temperature coefficient. The negative temperature coefficient seems to be used more often. The reason for this is that a wider range of values are available in the negative temperature coefficient thermistors.

Sometimes a transistor is used to stabilize another transistor. This may be done because another transistor is nothing more than two diodes back to back, and either portion may be used instead of the diodes that were used in a previous circuit.

### Voltage Feedback Stabilization.

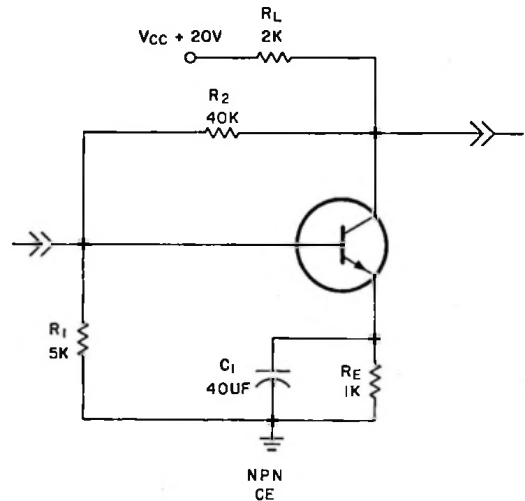

Figure 3-76

Another method that is sometimes used for bias stabilization of both  $R_{BE}$  and  $I_{CBO}$  is shown in figure 3-76. Instead of returning  $R_2$  to  $V_{CC}$ , the top side of  $R_2$  is returned to the collector of the transistor.

Examine figure 3-77 to see if the correct bias exists in this circuit. Applying the first rule for correct biasing, first determine the type of transistor in use. Because the arrow is pointing away from the base section, this transistor is an NPN type transistor. Now write the letters for the transistor on the back side of the diagram. Then starting at the emitter match the polarity, negative in this case to match

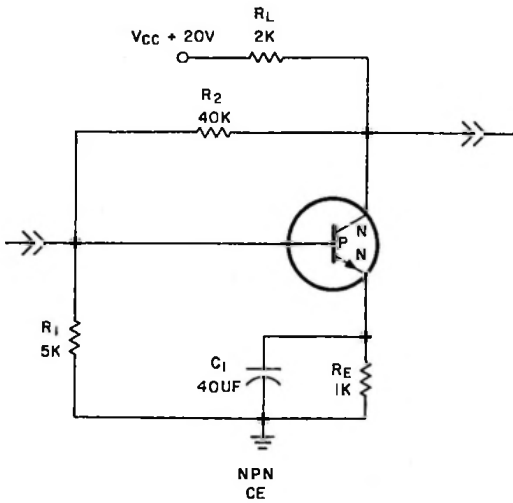

Figure 3-77

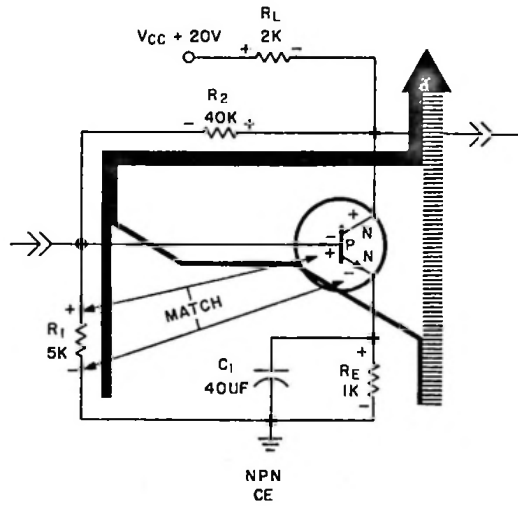

Figure 3-79

“N” material, and go in series, negative to positive, negative to positive. This is the bias polarity that is desired for this transistor.

The base-emitter junction, therefore, has the correct bias as indicated in figure 3-79, because the voltage drop across  $R_1$  is also felt across the base-emitter junction, and this is the polarity of bias required to forward bias the base-emitter junction.

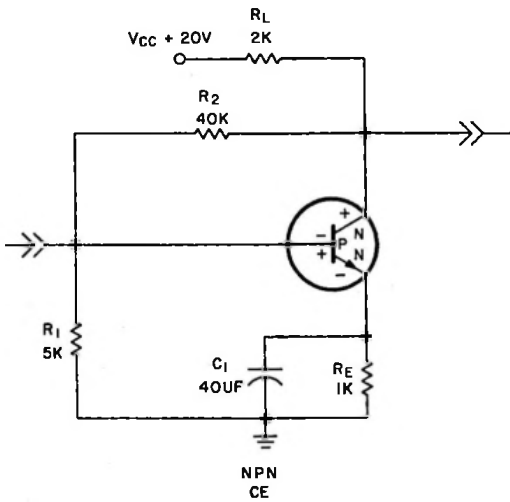

Figure 3-78

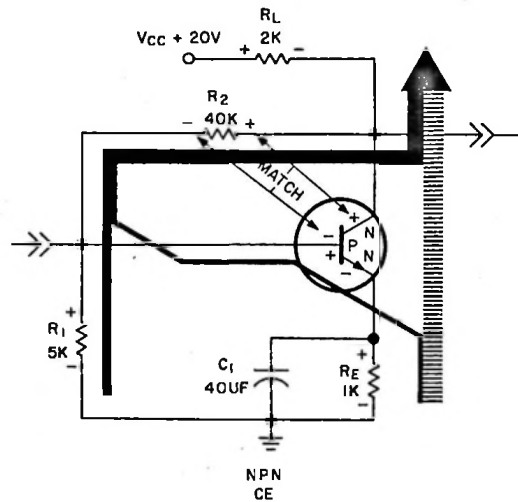

Figure 3-80

Now examine figure 3-78 to see if the correct bias polarity is available from the biasing network. The biasing network consists of  $R_1$ ,  $R_2$ , and  $R_L$ . Current is flowing through the voltage divider from bottom to top toward the plus 20-volt collector supply, developing a negative to positive from bottom to top of  $R_1$  and negative to positive from left to right of  $R_2$ .

The voltage drop across  $R_2$ , as shown in figure 3-80, also is felt across the base-collector junction. This correctly biases the base-collector junction, and the transistor is biased correctly.

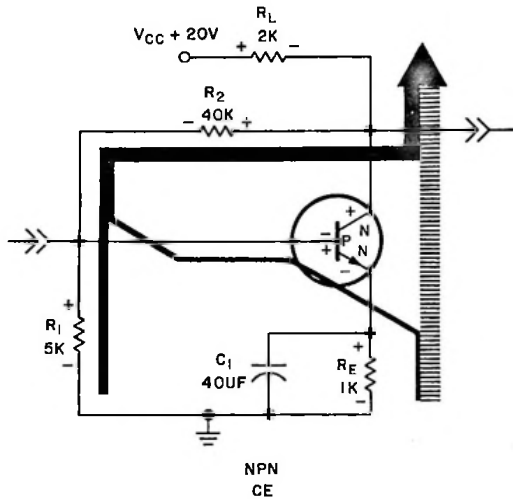

Figure 3-81

Now examine figure 3-81 for an explanation of how this circuit works. The collector current,  $I_C$ , flows from the emitter to the collector and through  $R_L$ . Additionally, the bias current which flows through  $R_1$  and  $R_2$  also flows through  $R_L$ . This biasing arrangement is very similar to previous biasing arrangements that we have examined. The difference here lies in the fact that the voltage to the voltage-dividing network, consisting of  $R_1$  and  $R_2$ , is dependent upon the amount of current which is flowing in the collector, because a greater collector current will cause a larger drop across  $R_L$  which, in turn, would decrease the voltage available to the base biasing network consisting of  $R_1$  and  $R_2$ .

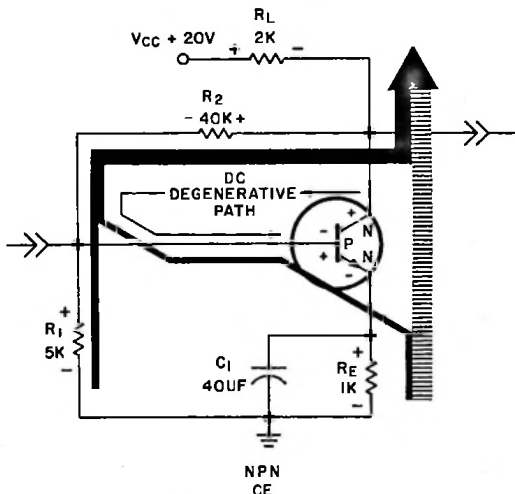

Figure 3-82

Assume now that the temperature of the transistor were to increase. If this would happen, the collector current,  $I_C$ , would try to increase. Increasing the collector current would increase the voltage drop across  $R_L$ . This would cause the bottom side of  $R_L$  to go in a more negative direction. This negative-going signal will be degeneratively coupled back from the collector to the base as shown in figure 3-82. More negative on a "P" type material will try to cut off the transistor, decreasing  $I_C$ . Therefore, even though  $I_C$  tries to increase due to a temperature change, the transistor is stabilized by degeneration through  $R_2$ ; no change occurs in the collector current. This is called voltage feedback stabilization or self-bias. If  $R_2$  is a very large value resistor, we would find that the degeneration to the signal would be quite small, while degeneration by d-c or due to temperature changes would be large, temperature stabilizing the collector of this transistor. If the value of  $R_2$  and  $R_1$  is small, you would find that there also would be degeneration of the signal due to the feedback through  $R_2$  from the collector to the base. In this method of bias stabilization,  $R_2$  is usually quite large. This will not deteriorate  $I_{CBO}$  stabilization of the transistor, because whether it is  $I_{CBO}$  which causes an increase in the collector current, or the base-emitter resistance change causing an increase in the collector current, both changes will be felt back through  $R_2$  to the base of the transistor and provide a fairly good bias stabilization. This is called voltage feedback stabilization in contrast to the emitter stabilization sometimes called current feedback.

Methods of Biasing.

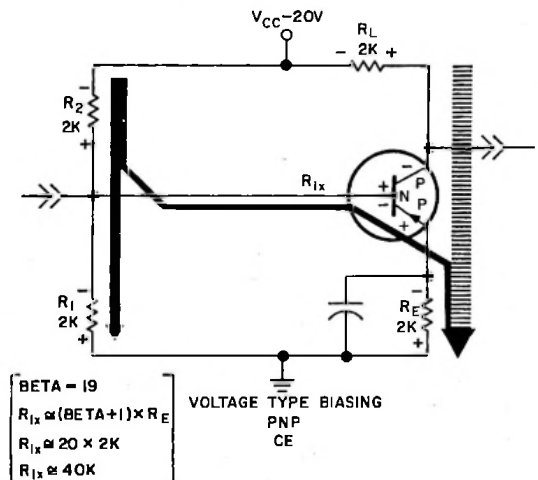

Figure 3-83

The two major ways of biasing a transistor are called voltage biasing and current biasing. Figure 3-83 is a sample of voltage biasing. The input resistance at

CHAPTER 3  
Bias Stabilization

the base of the transistor,  $R_{ix}$ , is approximately equal to beta plus 1 times  $R_E$ . With beta being equal to 19, the input resistance is equal to 20 times 2K or a value of 40K.

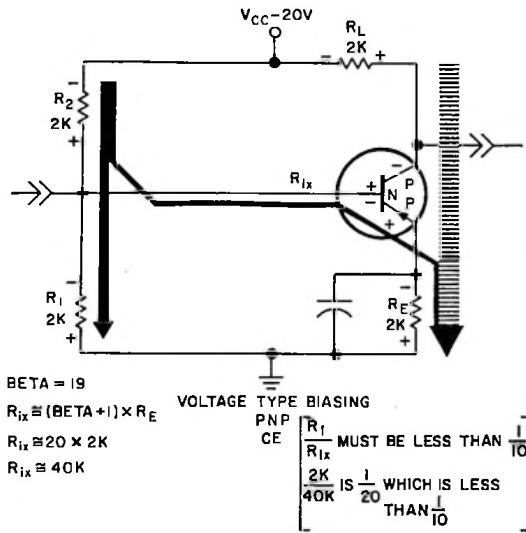

Figure 3-84

To have voltage-type biasing, as in figure 3-84, the value of  $R_1$  must be less than one tenth the value of the input resistance at the base of the transistor.

In other words, with small values of  $R_1$  and  $R_2$ , as shown in figure 3-84, this ratio is equal to 2K divided by 40K which equals one twentieth. This is less than one tenth, so the circuit is using voltage-type biasing. Low values of  $R_1$  and  $R_2$  do not necessarily indicate voltage-type biasing, but it is generally true.

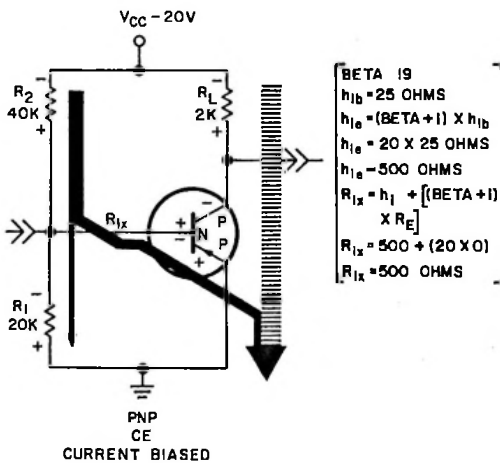

Figure 3-85

Figure 3-85 shows a circuit that is using current-type biasing. The input resistance at the base of the transistor,  $R_{ix}$ , can be found as shown. By multiplying beta plus 1 times  $h_{ib}$ , the value for  $h_{ie}$  is found to be equal to 500 ohms. The input resistance is then equal to  $h_{ie}$  plus the quantity beta plus 1 times  $R_E$ . This results in a value of 500 plus 20 times zero, because  $R_E$  is equal to zero ohm. Therefore, the input resistance of the base is equal to 500 ohms.

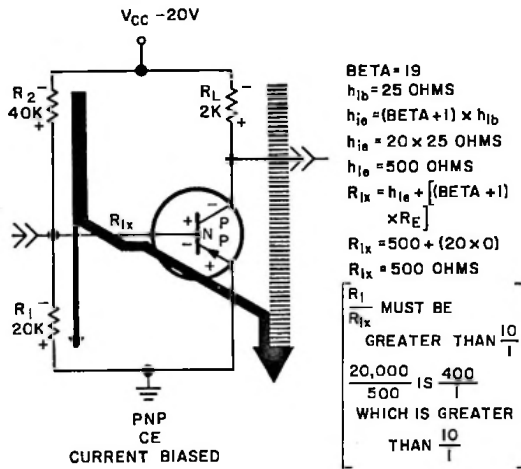

Figure 3-86

In current-type biasing, shown in figure 3-86, the value of  $R_1$  must be ten times the value of the input resistance at the base of the transistor. The ratio of  $R_1$  over  $R_{ix}$  in this particular circuit then is equal to 20,000 over 500, which equals 400 over 1. This is greater than 10 to 1, so the circuit must be current biased.

For values of  $R_1$  to  $R_{ix}$  that fall somewhere between that required for voltage-type biasing and current-type biasing, the circuit must be considered a combination of current- and voltage-type biasing. In this case, the parallel value of  $R_1$  and  $R_{ix}$  must be determined and then the circuit treated as a voltage-type bias network to determine the quiescent operating voltages and currents.

If the circuit has been determined to be a current-biased circuit, as in figure 3-87, the base current may be determined, as indicated, by considering  $R_1$  an open and the voltage across  $R_2$  equal to  $V_{CC}$ . Also assume that the voltage from the base to the emitter is equal to zero and that the current through  $R_2$  is equal to the base current,  $I_B$ . Once the base current has been found in a circuit, the collector current, emitter current, and collector voltage may be found as previously shown.



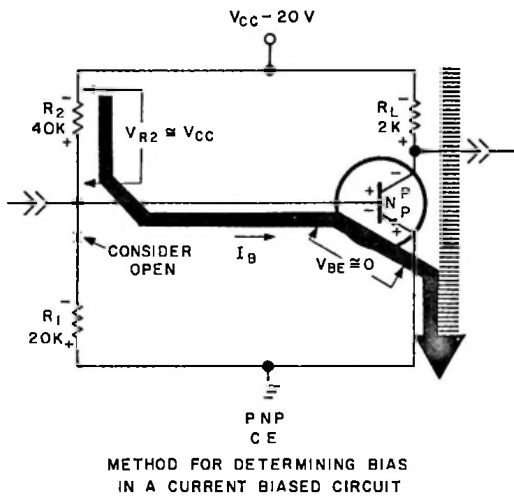

Figure 3-87

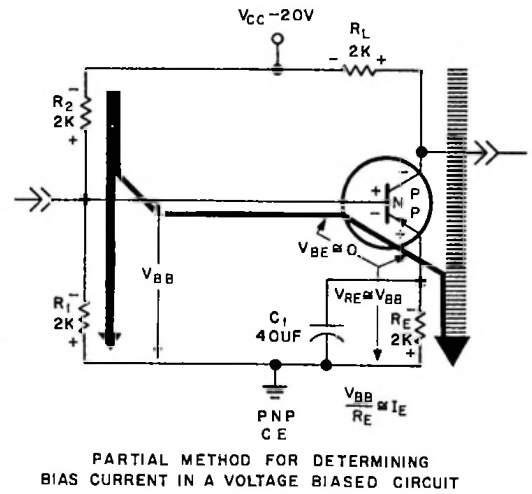

Figure 3-89

Figure 3-88 shows part of the method for determining bias current in a voltage-biased circuit. The first step in determining the quiescent currents is to assume that the base lead is open and that the voltage at the base,  $V_{BB}$ , is determined by  $R_1$  and  $R_2$  entirely.

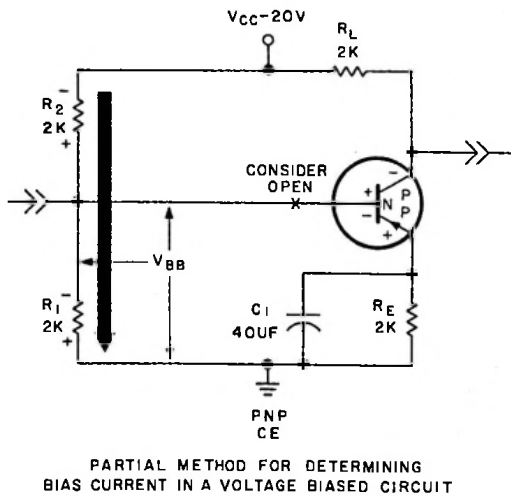

Figure 3-88

Now assume that the voltage from base to emitter  $V_{BE}$  is equal to zero and that the entire  $V_{BB}$  is dropped across  $R_E$  as shown in figure 3-89. This means that  $V_{RE}$  is approximately equal to  $V_{BB}$ , which is determined by  $R_1$  and  $R_2$ . Dividing  $V_{BB}$  by  $R_E$  will give an approximate value of  $I_E$ , the emitter current.

Normally in this type of circuit  $I_B$ , the base current, is not an important factor for the technician to know, so it is not determined. It could be determined by dividing the emitter current by gamma. To find the collector current, it is only necessary to multiply the approximate value of  $I_E$  by alpha. If alpha is unknown, alpha may be assumed to be equal to 1. In this case, the value of the collector current would be equal to the emitter current.

### Stability Equations.

$$S_I = \frac{\Delta I_E}{\Delta I_{CBO}} \approx \frac{R_1}{R_E} + 1, \text{ IDEAL} = 0$$

$$S_\alpha = \frac{\Delta I_E}{\Delta V_{BE}} \approx \frac{R_2 + \beta \times R_E}{h_{ie}}, \text{ IDEAL} = 0$$

$$S_V = \frac{\Delta V_{CE}}{\Delta I_{CBO}} \approx (S_I R_E + R_L) 2S_I, \text{ IDEAL} = 0$$

Figure 3-90

CHAPTER 3  
Bias Stabilization

When discussing the bias stabilization of a circuit, it is sometimes helpful to explain the stability of the circuit by the use of one of the stability factors of which there are three:  $S_i$ ,  $S_e$ , and  $S_v$ .

$S_i$  indicates the rate of change of  $I_E$  as a function of  $I_{CBO}$ .  $S_e$  indicates the rate of change of  $I_E$  as a function of  $V_{BE}$ .  $S_v$  is equal to the change in the collector voltage as a function of the change in the cutoff current,  $I_{CBO}$ . The stability factors,  $S_e$  and  $S_v$ , are not generally used.  $S_e$  is not generally used because the low value of  $S_i$  obtained with an emitter resistor automatically causes the low value of  $S_e$ .  $S_v$  will be low, which is desirable if the value of  $R_L$  plus  $R_E$  is small.  $S_i$  is the stability factor most commonly used.  $S_i$  is equal to  $R_1$  divided by  $R_E$  plus 1.  $S_i$ , for good stability, should be equal to 10 or less. Consequently,  $R_1$  over  $R_E$  must equal 9 or less. If it does, we can assume that the circuit is fairly well stabilized and will operate over a nominal range of temperatures without creating a large change in collector current.

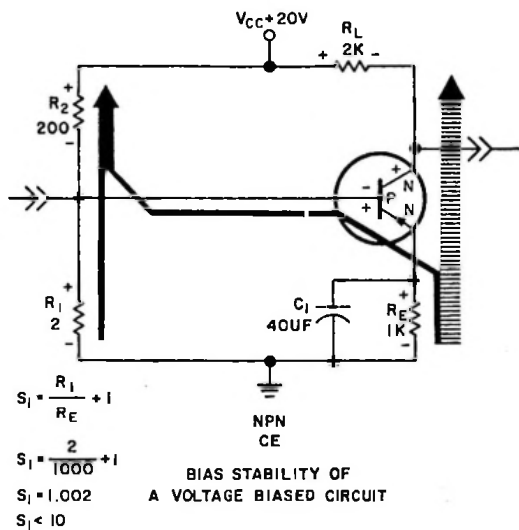

Figure 3-91

Examine a few circuits, and determine the stability factors of these circuits.

For the first problem in bias stability of a circuit, use the values that would indicate voltage-type biasing of the transistor. As indicated in figure 3-91,  $R_2$  equals 200 ohms,  $R_1$  equals 2 ohms, and assume the value of  $R_E$  as 1K. Using the stability equation,  $S_i$  is equal to  $R_1$  over  $R_E$  plus 1, then  $S_i$  is equal to 2 over 1000 plus 1, or 1.002. As previously stated, for good temperature stability,  $S_i$  should be less than 10. This is equal to less than 10, which indicates a very good stability. The smaller the value of  $S_i$  the greater the stability, but  $S_i$  can never be less than 1.

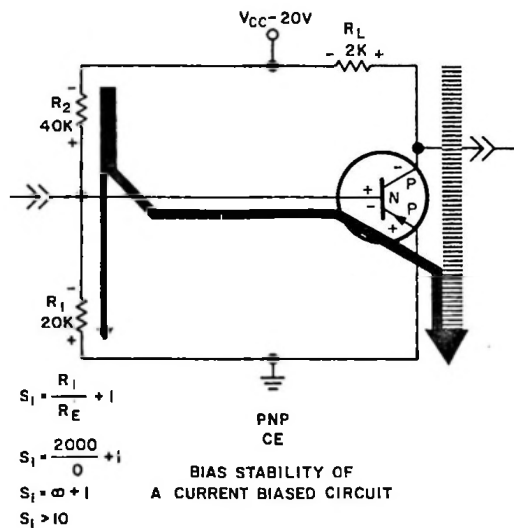

Figure 3-92

Observe figure 3-92 which is a current-biased PNP CE amplifier. This is indicated by the large values of  $R_1$  and  $R_2$ , and in this case complete absence of  $R_E$ . Using these values, we now have a stability factor  $S_i$  which is equal to 1 plus  $R_1$  over  $R_E$  or 200 over zero. This is an  $S_i$  of infinity. This is not the best stability factor. To increase the stability to 10, it would be necessary to increase the value of  $R_E$  from zero to 2K which would then necessitate changing the value of  $R_2$  to maintain the correct bias. This shows that current biasing is not very stable. As a general rule, it can be said that the circuit is well stabilized if  $S_i$ , or the ratio of  $R_1$  to  $R_E$ , is less than 10.

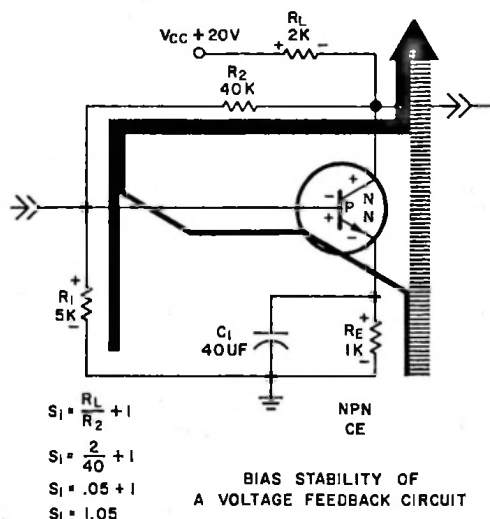

Figure 3-93

In figure 3-93,  $S_i$  in a circuit of this type can be figured by the ratio of  $R_L$  over  $R_2$  plus 1, and should be 10.0 or less for good bias stability. In this case  $S_i$  is equal to 2 divided by 40 plus 1 for a value of 1.05.  $S_i$  can be useful to you, the technician, if the change in  $I_{CBO}$  over a given temperature range is known. The change in  $I_{CBO}$  times  $S_i$  is equal to the change in the emitter current,  $\Delta I_e$ , for the same change in temperature.

In other words, if the change in  $I_{CBO}$  over a given range of temperature was equal to 10 microamperes and  $S_i$  was equal to 10, there would be a 100-micro-ampere change in the emitter current for the same range of temperatures.

$I_{CBO}$  increases exponentially with temperature, doubling in value every 8° to 10°C. A typical value of  $I_{CBO}$  in a germanium transistor is about 5 microamperes at 25°C. If a temperature were to increase to 75°C, however,  $I_{CBO}$  would increase to nearly 160 microamperes. In other words, over a change of 50°C, the cutoff current doubles 5 times.

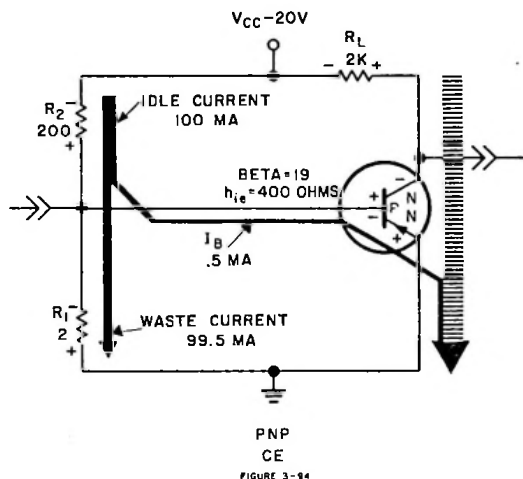

Figure 3-94

The question might arise, "Why not use the voltage method of biasing, rather than the current method of biasing?" The voltage method is more stable. The answer to this lies in the amount of idle current pulled by the circuit. If  $R_2$  equals 200 ohms and  $R_1$  equals 2 ohms, as in figure 3-94, the circuit is pulling 100 mills of which we are only using 0.5 mill. In other words, 99.5 mills of current is being wasted, and the circuit is inefficient to that extent.

This system would be rather impractical if this circuit were going to be operated off batteries. If it were being operated off a power supply with an unlimited

source of power, then this circuit could be used, and it would be very practical.

Of course, if the equipment is going to be operated at one temperature and one temperature only, bias stability is not important; but if it is going to be operated over a range of temperatures, the normal range that we would find in a temperate climate, from 30° below to 100° above 0°F, then we do need bias stabilization.

Transistor Manual Interpretation.

JEDEC NO. TYPE USE	MAXIMUM RATINGS				ELECTRICAL PARAMETERS					
	PC MW @25°C	$V_{CE}$	$V_{CE}$	$I_{CMA}$	MIN $h_{FE}$	MIN $h_{FE}$	MIN $f_{T(MC)}$	MIN $C_{cDB}$	MAX $I_{CO}$	$V_{CE}$
2N612 PNP AF	180	-20	-150	85	60T	1	.6T	37	-25	-20
2N613 PNP AF OUT	180	-20	-200	85	.97A	1	.85T	32	-25	-20
2N614 PNP IF	125	-15	-150	85	4.5T	.5	3T	24T	-6	-20
2N615 PNP IF	125	-15	-150	85	7.5T	.5	3T	34T	-6	-20
2N616 PNP IF	125	-12	-150	85	2.5T	.5	9T	20T	-6	-15
2N617 PNP OSC	125	-12	-150	85	1.5T	.5	7.5T	30T	6	-15
2N618 PNP PWR	45W	-60*	-3A	50	60*	-1A	5KC	-3MA	-60	
2N622 NPN SI AF	400	50*	50	160	25T*	.5	.3	34T	.1	30
2N624 PNP RF	100	-20	-10	100	20	2	12.5	20T	-30	-30
2N625 NPN SW	2.5W	30		100	30*	50			100	-40
2N631 PNP AF OUT	170	-20	-50	85	150T	10	1.2T	35T	-25	-20
2N632 PNP AF OUT	150	-24	-50	85	100T	10	1T	25T	-25	-20
2N633 PNP AF OUT	150	-30	-50	85	60T	10	.8T	25T	-25	-20
2N634 NPN SW	150	20	300	85	15*	200	5		5	5
2N634A NPN SW	150	20	300	85	40*	10	5		6	25

Figure 3-95

It sometimes becomes necessary to refer to a transistor manual to determine the specifications for the transistor. The specifications, as shown in the transistor manual, are not written as alpha, beta, or gamma, and there are a number of things given which we have not discussed. In figure 3-95, you see a typical page out of a transistor manual.

On the left-hand side of the page, as shown in figure 3-96, is a number which corresponds to the type of the transistor. This is labeled "JEDEC". These initials stand for Joint Electron Devices Engineering Council. All transistors of any individual type, for instance the 2N612, no matter who manufactures them, have the same general specifications. A type is given directly to the right of the JEDEC number. The 2N612 is listed as a PNP.

CHAPTER 3  
Bias Stabilization

JEDEC			MAXIMUM RATINGS			
			P <sub>CMW</sub> @25°C	BV <sub>CE</sub> BV <sub>CB</sub> *	I <sub>CM</sub>	T <sub>J</sub> °C
NO.	TYPE	USE				
2N612	PNP	AF	180	-20	-150	85
2N613	PNP	AF OUT	180	-20	-200	85
2N614	PNP	IF	125	-15	-150	85
2N615	PNP	IF	125	-15	-150	85
2N616	PNP	IF	125	-12	-150	85
2N617	PNP	OSC	125	-12	-150	85
2N618	PNP	PWR	45W	-80*	-3A	90
2N622	NPN	S, AF	400	50*	50	160
2N624	PNP	RF	100	-20	-10	100
2N625	NPN	SW	2.5W	30		100
2N631	PNP	AF OUT	170	-20	-50	85
2N632	PNP	AF OUT	150	-24	-50	85
2N633	PNP	AF OUT	150	-30	-50	85
2N634	NPN	SW	150	20	300	85
2N634A	NPN	SW	150	20	300	85

Figure 3-96

JEDEC			MAXIMUM RATINGS			
			P <sub>CMW</sub> @25°C	BV <sub>CE</sub> BV <sub>CB</sub> *	I <sub>CM</sub>	T <sub>J</sub> °C
NO.	TYPE	USE				
2N612	PNP	AF	180	-20	-150	85
2N613	PNP	AF OUT	180	-20	-200	85
2N614	PNP	IF	125	-15	-150	85
2N615	PNP	IF	125	-15	-150	85
2N616	PNP	IF	125	-12	-150	85
2N617	PNP	OSC	125	-12	-150	85
2N618	PNP	PWR	45W	-80*	-3A	90
2N622	NPN	S, AF	400	50*	50	160
2N624	PNP	RF	100	-20	-10	100
2N625	NPN	SW	2.5W	30		100
2N631	PNP	AF OUT	170	-20	-50	85
2N632	PNP	AF OUT	150	-24	-50	85
2N633	PNP	AF OUT	150	-30	-50	85
2N634	NPN	SW	150	20	300	85
2N634A	NPN	SW	150	20	300	85

Figure 3-98

In the next column, as indicated by figure 3-97, is USE. Under the USE column may be listed whether the transistor is normally used as an i-f, switching, r-f transistor, or whatever it happens to be. The 2N612 is listed as an audio-frequency transistor.

Continuing to the right, as shown in figure 3-99, is a column indicating breakdown voltage collector to emitter, BV<sub>CE</sub>, or breakdown voltage collector to base, BV<sub>CB</sub>. If the quantity listed is collector to base, it will have an asterisk alongside it. The 2N612 lists a minus 20 and it does not have an asterisk, so this is the breakdown voltage from the collector to emitter, BV<sub>CE</sub>, or the maximum voltage this transistor can withstand without breaking down. The minus sign indicates that the voltage on the collector is minus in respect to the emitter.

JEDEC			MAXIMUM RATINGS			
			P <sub>CMW</sub> @25°C	BV <sub>CE</sub> BV <sub>CB</sub> *	I <sub>CM</sub>	T <sub>J</sub> °C
NO.	TYPE	USE				
2N612	PNP	AF	180	-20	-150	85
2N613	PNP	AF OUT	180	-20	-200	85
2N614	PNP	IF	125	-15	-150	85
2N615	PNP	IF	125	-15	-150	85
2N616	PNP	IF	125	-12	-150	85
2N617	PNP	OSC	125	-12	-150	85
2N618	PNP	PWR	45W	-80*	-3A	90
2N622	NPN	S, AF	400	50*	50	160
2N624	PNP	RF	100	-20	-10	100
2N625	NPN	SW	2.5W	30		100
2N631	PNP	AF OUT	170	-20	-50	85
2N632	PNP	AF OUT	150	-24	-50	85
2N633	PNP	AF OUT	150	-30	-50	85
2N634	NPN	SW	150	20	300	85
2N634A	NPN	SW	150	20	300	85

Figure 3-97

JEDEC			MAXIMUM RATINGS			
			P <sub>CMW</sub> @25°C	BV <sub>CE</sub> BV <sub>CB</sub> *	I <sub>CM</sub>	T <sub>J</sub> °C
NO.	TYPE	USE				
2N612	PNP	AF	180	-20	-150	85
2N613	PNP	AF OUT	180	-20	-200	85
2N614	PNP	IF	125	-15	-150	85
2N615	PNP	IF	125	-15	-150	85
2N616	PNP	IF	125	-12	-150	85
2N617	PNP	OSC	125	-12	-150	85
2N618	PNP	PWR	45W	-80*	-3A	90
2N622	NPN	S, AF	400	50*	50	160
2N624	PNP	RF	100	-20	-10	100
2N625	NPN	SW	2.5W	30		100
2N631	PNP	AF OUT	170	-20	-50	85
2N632	PNP	AF OUT	150	-24	-50	85
2N633	PNP	AF OUT	150	-30	-50	85
2N634	NPN	SW	150	20	300	85
2N634A	NPN	SW	150	20	300	85

Figure 3-99

The next major breakdown, as indicated by figure 3-98, is MAXIMUM RATING; this is the maximum power, voltage, current, and temperature that this transistor can withstand. Under PEAK COLLECTOR POWER (P<sub>cmw</sub>) is the peak power the collector can dissipate in milliwatts at 25°C. For the 2N612, this is 180 milliwatts.

JEDEC			MAXIMUM RATINGS			
			$P_{cMAX}$ @25°C	$V_{CE}^*$	$I_C$ MA	$T_J$ °C
NO.	TYPE	USE				
2N612	PNP	AF	180	-20	-150	85
2N613	PNP	AF OUT	160	-20	-200	85
2N614	PNP	IF	125	-15	-150	85
2N615	PNP	IF	125	-15	-150	85
2N616	PNP	IF	125	-15	-150	85
2N617	PNP	OSC	125	-15	-50	85
2N618	PNP	FWR	45W	-80V	-3A	90
2N622	NPN	S, AF	400	50V	50	150
2N624	PNP	RF	100	-20	-10	100
2N625	NPN	SW	2.2W	30		100
2N631	PNP	AF OUT	70	-20	-50	85
2N632	PNP	AF OUT	60	-20	-50	85
2N633	PNP	AF OUT	60	-30	-50	85
2N634	NPN	SW	150	20	300	85
2N634A	NPN	SW	20	20	300	85

Figure 3-100

The next column lists maximum  $I_C$  in milliamperes as indicated by figure 3-100. For the 2N612 a minus 150 milliamperes is listed. The minus sign, in this case, indicates that the current is flowing into the transistor rather than out of it. The next column gives  $T_J$ °C, or temperature of the junction in degrees centigrade. The maximum that the 2N612 can withstand is 85°C without damage to the transistor.

ELECTRICAL PARAMETERS						
JEDEC NO.	MIN		MIN	MAX	MAX	MAX
	$h_{fe}$ - $h_{FE}$	@ $I_C$ MA				
2N612	96 $\alpha$ T	1	5	10	100	100
2N613	87 $\alpha$ T	1	5	10	100	100
2N614	4.5T	5	2	2	100	100
2N615	7.5T	5	2	2	100	100
2N616	8.5T	5	2	2	100	100
2N617	15T	5	2	2	100	100
2N618	60V	1A	5	5	100	100
2N622	25T	5	5	5	100	100
2N624	20	2	2	2	100	100
2N625	50V	50	50	50	100	100
2N631	150T	0	2T	15T	25V	200
2N632	100T	0	1T	25T	25V	200
2N633	50T	0	1T	25T	25V	200
2N634	150T	200	5	5	5	5
2N634A	40V	10	10	10	10	10

Figure 3-101

The next major breakdown, as pointed out by figure 3-101, is the electrical parameters, which will give the working values of the transistor. Under minimum  $h_{fe}$  or  $h_{FE}$  asterisk, for the 2N612, is listed a 0.96

alpha T. This indicates that for this transistor the alpha is 0.96 and that this is typical rather than absolute minimum. Also the alpha sign indicates that this is an alpha. If the alpha sign is not there,  $h_{fe}$ , whether it is lowercase or uppercase, indicates beta. Lowercase  $h_{fe}$  is small signal or a-c beta. Capital  $H_{FE}$  is d-c beta. Therefore, the transistor forward current transfer ratio is given in alpha, and to find beta, it would be necessary to use the conversion equation. This particular alpha was obtained at a collector current of 1 milliampere as indicated in the next column.

ELECTRICAL PARAMETERS						
JEDEC NO.	MIN	MIN	MIN	MAX	MAX	MAX
2N612	96 $\alpha$ T	1	5T	10	100	100
2N613	87 $\alpha$ T	1	5T	10	100	100
2N614	4.5T	5	2	2	100	100
2N615	7.5T	5	2	2	100	100
2N616	8.5T	5	2	2	100	100
2N617	15T	5	2	2	100	100
2N618	60V	1A	5	5	100	100
2N622	25T	5	5	5	100	100
2N624	20	2	2	2	100	100
2N625	50V	50	50	50	100	100
2N631	150T	0	2T	15T	25V	200
2N632	100T	0	1T	25T	25V	200
2N633	50T	0	1T	25T	25V	200
2N634	150T	200	5	5	5	5
2N634A	40V	10	10	10	10	10

Figure 3-102

Directly to the right of that is a column listing minimum  $f_{hfb}$  in megacycles as indicated in figure 3-102. In this particular case, notice 2N612 is listed as .6T or 0.6 megacycle typical. This is the frequency where the forward current transfer ratio alpha falls off to 0.707 of its value at 1 kilocycle. The  $h_{fe}$  column, by specifying alpha, indicates this was measured in the common base configuration, and the T indicates typical. The cutoff frequency in the common emitter configuration could be found by dividing beta into this value.

The next column to the right, as shown in figure 3-103, lists  $G_e$  in decibels. This indicates power gain in decibels in a common emitter configuration. The next column indicates maximum  $I_{CBO}$ . This is the same as  $I_{CO}$ , or  $I_{CEO}$  divided by beta and is listed in microamperes. In the case of the 2N612 this is minus 25 microamperes. This indicates that at 25°C, at a collector voltage of 20 volts, which is in the next column, there will be 25 microamperes of  $I_{CBO}$ ; and

ELECTRICAL PARAMETERS									
VE	VEBO	V <sub>CE</sub>	V <sub>BE</sub>	I <sub>B</sub>	I <sub>C</sub>	I <sub>CE</sub>	MIN	MAX.	
MO	V	V	V	mA	mA	mA	Ge	DB	ICO(μa) @ VCB
2N616	0.5	10	0.7	5	5	5	37	-25	-20
2N618	0.5	10	0.7	5	5	5	37	-25	-20
2N619	0.5	10	0.7	5	5	5	37	-25	-20
2N620	0.5	10	0.7	5	5	5	37	-25	-20
2N621	0.5	10	0.7	5	5	5	37	-25	-20
2N622	0.5	10	0.7	5	5	5	37	-25	-20
2N623	0.5	10	0.7	5	5	5	37	-25	-20
2N624	0.5	10	0.7	5	5	5	37	-25	-20
2N625	0.5	10	0.7	5	5	5	37	-25	-20
2N626	0.5	10	0.7	5	5	5	37	-25	-20
2N627	0.5	10	0.7	5	5	5	37	-25	-20
2N628	0.5	10	0.7	5	5	5	37	-25	-20
2N629	0.5	10	0.7	5	5	5	37	-25	-20
2N630	0.5	10	0.7	5	5	5	37	-25	-20
2N631	0.5	10	0.7	5	5	5	37	-25	-20
2N632	0.5	10	0.7	5	5	5	37	-25	-20
2N633	0.5	10	0.7	5	5	5	37	-25	-20
2N634	0.5	10	0.7	5	5	5	37	-25	-20
2N635	0.5	10	0.7	5	5	5	37	-25	-20

Figure 3-103

the negative indicates it is flowing into the transistor. The very next column lists the voltage collector to base,  $V_{cb}$ , at which  $I_{CBO}$  was measured.

Review.

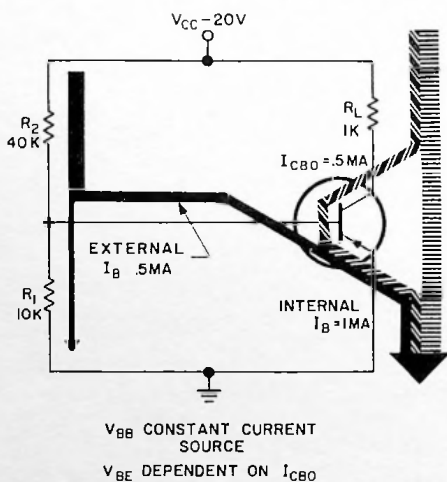

Figure 3-104

Now let us review some of the material that we have covered during this section of the tape-slide presentation. It was found, as indicated by figure 3-104, that if the external base current would remain constant, then any change in the value of  $I_{CBO}$  would cause a

change in the voltage from base to emitter,  $V_{BE}$ . Therefore, the voltage from the base to the emitter becomes dependent upon the value of  $I_{CBO}$  in this case. Any increase in the value of  $I_{CBO}$  would increase the value of  $V_{BE}$ . It was pointed out that this was not desirable, as any increase in the voltage from base to emitter would cause an increase in the internal base current which, in turn, would cause an increase in the collector current.

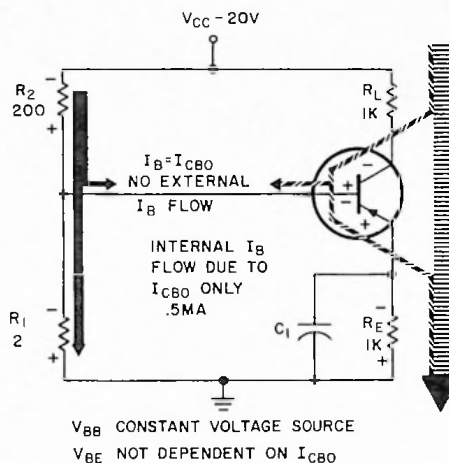

Figure 3-105

Figure 3-105 shows one method of combating the changes in  $I_{CBO}$ . By decreasing the size of  $R_1$  and  $R_2$ , the voltage at the base of the transistor is no longer dependent upon the value of  $I_{CBO}$ , but rather upon the values of  $R_1$  and  $R_2$ . Therefore, as  $I_{CBO}$  increases the external base current will decrease; this maintains the internal base current at a constant value. If the internal base current remains constant, the voltage from base to emitter will remain constant also, and  $V_{BE}$  will not be dependent upon the value of  $I_{CBO}$ . If the value of the internal base current does not change as a function of  $I_{CBO}$ , the collector current,  $I_C$ , will not change as a function of  $I_{CBO}$ . This was true even if the value of  $I_{CBO}$  increased to a value which is equal to the original  $I_B$ .

Reexamine the curves for temperature stabilizing a transistor as shown in figure 3-106. This diagram readily points out the fact that for good bias stabilization the emitter resistance,  $R_E$ , must be kept as large as possible, while  $R_B$ , the combined parallel resistance of  $R_1$  and  $R_2$ , must be kept as low as possible. This is shown in curve "C," while curve "A" shows the approximate reverse of this condition

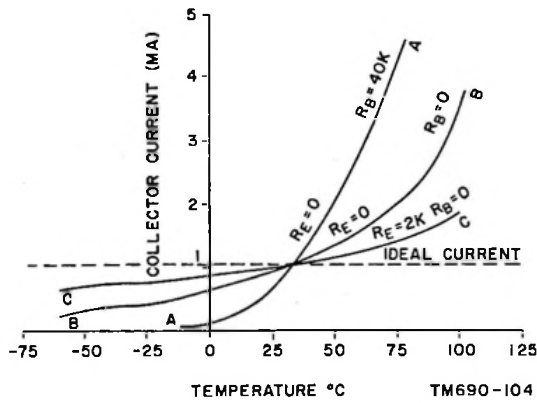

Figure 3-106

and indicates that for a slight change in the temperature of the junction the collector current would increase appreciably. Curve "B" shows a condition where  $R_E$  is equal to zero, and  $R_B$  is equal to zero. As can be seen, decreasing the value of  $R_B$  to zero ohm does improve the temperature stabilization of the transistor, but as pointed out by curve "C," increasing the value of  $R_E$  provides a very large improvement in the bias stabilization of this circuit.

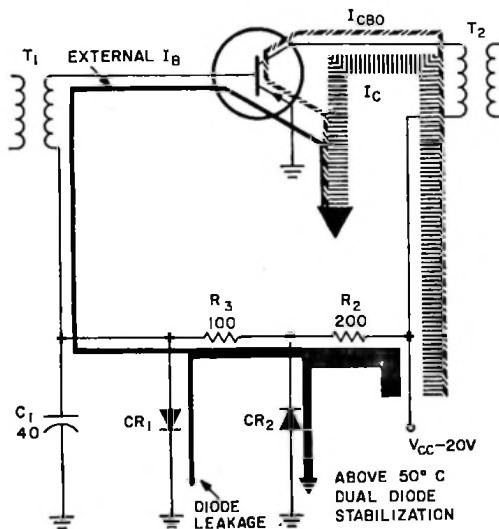

Figure 3-107

Figure 3-107 shows a circuit that was found to be very well stabilized. This circuit is known as a duodiode stabilized circuit. The function of  $CR_1$ , which is

a back-biased diode, is to prevent any changes in the value of the internal base current as a function of  $I_{CBO}$ . On the other hand  $CR_2$ , a forward-biased diode, provides temperature stabilization of the internal base current as a function of the base-emitter resistance changes.

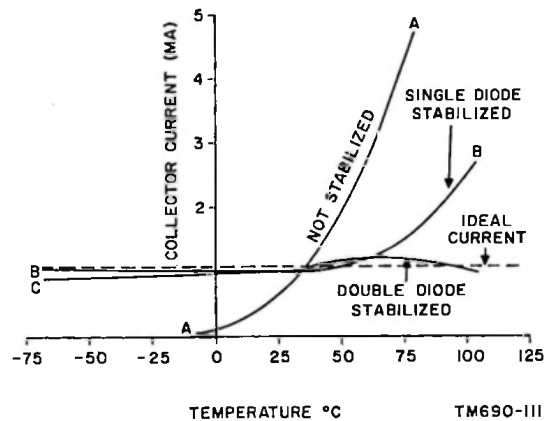

Figure 3-108

Although the duodiode stabilized circuit is very stable over a wide range of temperatures, as shown by figure 3-108, the statement was made that the duodiode stabilized circuit is seldom used. This is because it is difficult to find diodes with the correct temperature coefficient to match the individual transistor, and the cost of a circuit of this variety is prohibitive unless bias stabilization is necessary over an extremely wide range of temperatures.

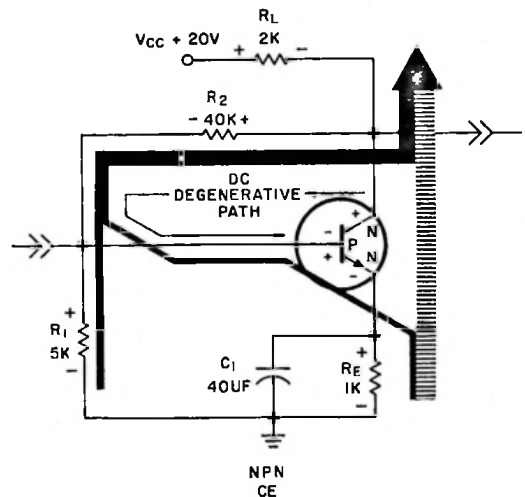

Figure 3-109

CHAPTER 3  
Bias Stabilization

Figure 3-109 shows another method for compensating the transistor circuit for both the effects of  $I_{CBO}$  and changes in  $R_{BE}$ . This circuit is known as the voltage feedback method of biasing in contrast to circuits using an emitter swamping resistor, which are called current feedback type circuits. This method of stabilization works upon the principles of a d-c degenerative path from the collector to the base. The a-c signal was not degenerated in this circuit to any appreciable amount because of the relatively large size of  $R_2$ .

$$S_i = \frac{\Delta I_E}{\Delta I_{CBO}} \approx \frac{R_1}{R_E} + 1, \text{ IDEAL} = 0$$

$$S_e = \frac{\Delta I_E}{\Delta V_{BE}} \approx \frac{R_2 + \beta \times R_E}{h_{ie}}, \text{ IDEAL} = 0$$

$$S_v = \frac{\Delta V_{CE}}{\Delta I_{CBO}} \approx (S_i R_E + R_L) 2S_i, \text{ IDEAL} = 0$$

Figure 3-110

Three stability factors are shown in figure 3-110. These three stability factors are  $S_i$ ,  $S_e$ , and  $S_v$ . Of the three stability factors, it was found that  $S_i$  is the stability factor most commonly used because of its simplicity, and the fact that if  $S_i$  has a low value  $S_e$  and  $S_v$  will also have a low value. To find  $S_i$ , it is only necessary to divide  $R_1$  by  $R_E$  and add 1 to the quantity found. For ideal conditions  $S_i$  should be equal to zero, but under actual circuit operations can never be less than 1.

The stability factor,  $S_i$ , was computed for a voltage-biased circuit as shown in figure 3-111. As we found previously, with low values of  $R_1$  and  $R_2$  and a relatively high value for  $R_E$ , the stability factor of this particular circuit is equal to 1.002. This results in an  $S_i$  of less than 10, so the circuit is said to be well stabilized.

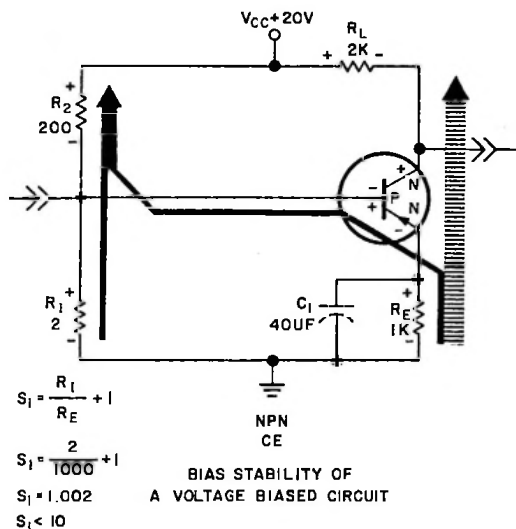

Figure 3-111

The stability factor,  $S_i$ , was also shown for a current-biased circuit similar to that shown in figure 3-112. If the value of  $R_1$  is made very large and no emitter resistance is in the circuit, the stability factor then is equal to infinity plus 1. This results in an  $S_i$  of much greater than 10. This indicates that for good stability it is a better practice to use voltage bias rather than current bias.

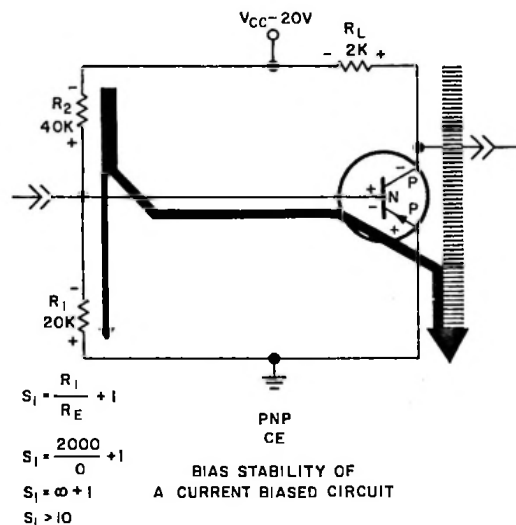

Figure 3-112



## Section 5 Work Problems

Some of the following problems are arranged so that you may conveniently underscore the correct word, or fill in the blanks, or answer thought questions in your own words. Disregard the value of  $R_1$  for all computations of input resistance.

1.  $I_{CBO}$  adds to the external  $I_B$ . (True or False)
2. For good bias stability, it is desirable to keep the value of \_\_\_\_\_ large and the value of \_\_\_\_\_ and \_\_\_\_\_ small.
3. If the change in \_\_\_\_\_ is known, the change in the \_\_\_\_\_ can be found by multiplying  $S_i$  times the change in \_\_\_\_\_.
4. Increasing the value of  $R_E$  of a circuit will cause the value of  $S_i$  to (increase or decrease).
5. Substituting the values given here for those in figure 3-84, find the quiescent  $V_{RE}$ ,  $I_C$ , and  $V_C$ . Also find  $S_i$  and the change in  $V_C$ , and  $V_C$  due to the increase of  $I_{CBO}$ , from 50°C to 75°C. Assume  $h_{ie}$  constant and use approximate equations. Assume  $\alpha = 1$ . (Show your work.)

$I_{CBO}$  at 50°C = 0.005 MA  
 $I_{CBO}$  at 75°C = 0.150 MA  
 Disregard  $h_{ie}$   
 $R_1 = 2.5K$

$R_2 = 5K$   
 $R_L = 1.5K$   
 $R_E = 1K$   
 $V_{CC} = -30$  volts

- A. Find  $V_{RE}$  at 50°C. Disregard  $I_{CBO}$ .
- B. Find  $I_C$  at 50°C. Disregard  $I_{CBO}$ .
- C. Find  $V_C$  at 50°C. Disregard  $I_{CBO}$ .
- D. Find  $S_i$ .
- E. Find the change in  $I_C$  due to the change in  $I_{CBO}$ .
- F. Find the change in  $V_C$  due to the change in  $I_{CBO}$ .

As soon as you have completed the above problems to the best of your ability, check your answers with those in appendix A. Each question counts ten points. A passing score is 75 percent. If your score is below or near 75 percent, it would be advisable to reread the second half of chapter 3.

When you have completed the course, please fill out the critique form found at the end of appendix A, and mail it to Collins Radio Company, Training Supervisor, Product Support Division Training Department, 321 Third Street S.E., Cedar Rapids, Iowa.

Answers to Section 1 Work Problems.

1. What are majority carriers?

Current carriers in a forward-biased diode.

2. What are minority carriers?

Current carriers in a back-biased diode.

3. (Majority or Minority) carriers cause current to flow in a reverse-biased diode.

4. A high current flows in a reverse-biased diode. (True or False)

5. A junction diode is a three-terminal device. (True or False)

6. A diode is said to be back biased if the polarity of the supply voltage is opposite to that of the type of material.

7. The proper method of checking a diode is to apply a high d-c voltage to it and measure the voltage drop. (True or False)

8. A diode is said to be forward biased if the polarity of the supply matches the type of material.

9. As temperature increases, the number of minority carriers (increases or decreases).

10. The current carriers in a forward-biased diode are (minority or majority) carriers.

11. Using the curve shown in figure 1-24 for 25°C, find the resistance for germanium and silicon diodes at the following currents and voltages. Your answers should be within 10 percent of those given below.

<u>Ge</u>		<u>Si</u>	
A. 0.15 volt	<u>500 ohms</u>	A. 0.6 volt	<u>2K ohms</u>
B. 1 mill	<u>200 ohms</u>	B. 0.8 volt	<u>800 ohms</u>
C. 2 mills	<u>115 ohms</u>	C. 2 mills	<u>455 ohms</u>
D. 0.25 volt	<u>83 ohms</u>	D. 1.0 volt	<u>333 ohms</u>
E. 0.3 volt	<u>46 ohms</u>	E. 1.2 volts	<u>180 ohms</u>

APPENDIX A  
Supplementary Data

12. Plot the values found in problem 11 for germanium and silicon diodes on the graphs provided in figure 1-63. Figures A-1 and A-2, below, illustrate the solution. Compare this with the plots you made on figure 1-63.

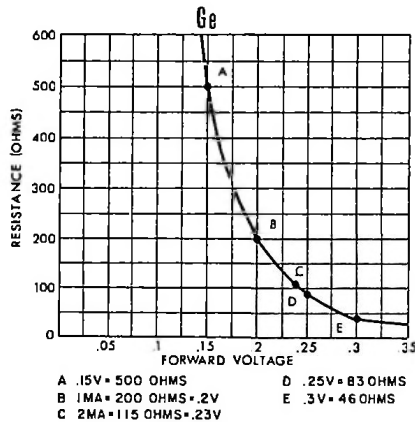

Figure A-1

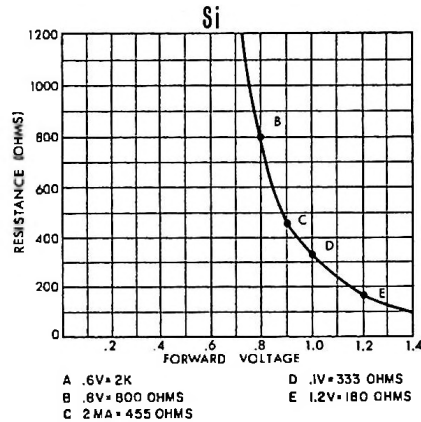

Figure A-2

13. The two basic differences between a zener diode and a regular diode are the power handling capabilities and the sharpness of the high-voltage knee.
14. The sudden increase in current at the zener point is due to the breaking of atomic bonds.
15. If the current is increased through a zener diode at a linear rate, the resistance (decreases or increases) at a (linear or nonlinear) rate.
16. Draw a picture showing the structure of a back-to-back zener diode.  
Refer to figure 1-29.
17. If a diode is rated at 10 watts at 25°C, how much wattage would it be capable of dissipating at 100°C? Use figure 1-31 as a reference.  
5 watts.
18. The back-to-front resistance ratio of a diode should be at least 20 to 1 if the diode is to be considered good.
19. Why are two or more diodes sometimes placed in series in rectifier circuits?  
To increase the voltage-handling capabilities.
20. In figure 1-39 if the capacitance of  $C_1$  is increased, what will happen to wave shape "B"?  
The frequency of repetition of wave shape "B" will decrease, or the pulses shown in the wave shape will be spaced at wider intervals.
21. If you intend to use a varicap in a circuit that displays a curve like that shown in figure 1-41A and the maximum change available in the bias voltage is 2 volts, at what point on the curve should the varicap be biased to obtain the maximum change in capacitance?  
1 volt.
22. The Shockley diode is a four-element device.

23. Before using a voltohmmeter to check a diode, what precautions should you take?

- A. Check the polarity of the voltage present on the ohmmeter leads.
- B. Use the lowest voltage available on the highest scale, in that order.

24. What basically causes the semiconductor diode to be more efficient than a tube?

The diode does not have filaments -- less power wasted.

25. A zener diode may be operated in the forward-biased region as a regular diode with no damage. (True or False)

Answers to Section 2 Work Problems.

1. If an NPN transistor is operating normally in a circuit, what polarity of voltage would you expect to find on the collector in respect to the emitter?

The collector normally is positive in respect to the emitter.

2. If a transistor is operating normally, the base-emitter junction may be considered a forward-biased diode.

3. List all of the currents found in a transistor in the order of decreasing magnitude. Start with the highest magnitude.

A.  $I_E$                        $I_E$

B.  $I_C$                        $I_C$

C.  $I_B$                       OR                       $\frac{\text{Internal } I_B}{\text{External } I_B}$

D.  $I_{CBO}$                        $I_{CBO}$

4. Internal  $I_B$  is equal to external  $I_B + I_{CBO}$ .

5.  $I_{CBO}$  (increases or decreases) as temperature decreases.

6.  $I_E$  is equal to  $I_B + I_C$ .

7. If  $I_B$  decreases,  $I_C$  (increases or decreases).

8. The CB configuration compares to the grounded-grid triode circuit.

9. If the voltage on the emitter of a transistor is negative in respect to the base and the transistor is conducting, then the transistor must be (a PNP or an NPN).

10. For all of the following parts, refer to the diagram in figure 2-35 and use the following values. Disregard the value of  $R_E$  in all computations.

$\alpha = 0.98$   
 $h_{ib} = 50 \text{ ohms}$   
 $R_1 = 1K$   
 $R_E = 1K$

$R_2 = 10K$   
 $R_L = 5K$   
 $\Delta I_e = 0.5 \text{ ma}$

A. Find  $\Delta I_C$ .

$$\Delta I_C = \alpha \times \Delta I_e = 0.98 \times 0.5 \text{ ma} = 0.490 \text{ ma}$$

APPENDIX A  
Supplementary Data

B. Find  $R_i$ .

$$R_i = \frac{R_E + h_{ib}}{R_E \times h_{ib}} \text{ but } R_E > 10 \times h_{ib} \therefore R_i = h_{ib} = 50 \text{ ohms}$$

C. Find  $A_R$ .

$$A_R = \frac{R_O}{R_i} = \frac{5000}{50} = 100$$

D. Find  $A_v$ .

$$A_v = \frac{V_{out}}{V_{in}} = \frac{2.45}{25 \times 10^{-3}} = \frac{2450}{25} = 98$$

$$V_{in} = \Delta I_e \times R_i = 0.5 \text{ ma} \times 50 = 25 \text{ mv}$$

$$V_{out} = \Delta I_c \times R_L = 0.490 \text{ ma} \times 5K = 2.45 \text{ volts}$$

$$\text{or } = A_R \times \alpha = 100 \times 0.98 = 98$$

E. Find  $A_p$ .

$$A_p = \frac{P_{out}}{P_{in}} = \frac{1.2 \times 10^{-3}}{12.5 \times 10^{-6}} = 96$$

$$P_{in} = V_{in} \times \Delta I_e = 25 \text{ mv} \times 0.5 \text{ ma} = 12.5 \text{ uw}$$

$$P_{out} = V_{out} \times \Delta I_c = 2.45 \times 0.49 \text{ ma} = 1.2 \text{ mw}$$

$$\text{or } = \alpha^2 \times A_R = 0.98^2 \times 100 = .96 \times 100 = 96$$

Answers to Section 3 Work Problems.

1. List the three configurations in the order of decreasing value.

A.  $A_i$  Common collector  
Common emitter  
Common base

B.  $A_v$  Common base  
Common emitter  
Common collector

C.  $A_p$  Common emitter  
Common base  
Common collector

D.  $R_i$  Common collector  
Common emitter  
Common base

2. Only the (CE, CB, or CC) configuration has a phase shift.

3. What polarity of signal would it be necessary to inject on the base of a PNP to decrease conduction?

Positive

4. What polarity of signal would it be necessary to inject on the emitter of an NPN to cause an increase in conduction?

Negative

5. What effect does increasing the value of  $R_E$  in a common emitter amplifier have on the following:

A. Voltage gain?

No effect

B. Current gain?

No effect

C. Input resistance?

No effect

6. What effect does increasing the value of  $R_L$  in a common emitter amplifier have on the following:

A. Voltage gain?

Increase

B. Current gain?

No effect

C. Input resistance?

No effect

7. If  $h_{ib}$  is equal to 75 ohms and beta equals 57, what will  $h_{ie}$  equal?

$$h_{ie} = (\text{beta} + 1) \times h_{ib} = (57 + 1) \times 75 = 4350 \text{ ohms}$$

8. Figure 2-80 is (a PNP or an NPN) common (base, emitter, or collector) configuration.

9. If the polarity of the supply in figure 2-80 were reversed, what type of transistor would be necessary to replace Q1?

An NPN

10. The phase of the signal at the output of figure 2-81 is (in phase or out of phase) with the signal at the input.

11. Substituting the values given here for those in figure 2-43, solve for  $A_i$ ,  $R_i$ ,  $A_v$ , and  $A_p$ . sregard the value of  $R_1$  in all computations.

$$\begin{aligned} R_1 &= 10K \\ R_2 &= 50K \\ R_L &= 5K \\ R_E &= 3K \end{aligned}$$

$$\begin{aligned} C_1 &= 40 \text{ mfd which} = \text{a-c short} \\ \text{Alpha} &= 0.995 \\ h_{ib} &= 50 \text{ ohms} \end{aligned}$$

A. Find  $A_i$ .

$$A_i = \frac{\text{alpha}}{1 - \text{alpha}} = \frac{0.995}{1 - 0.995} = 199$$

B. Find  $R_i$ .

$$R_i = (\text{beta} + 1) \times (R_E + h_{ib}) = (199 + 1) \times (0 + 50) = 200 \times 50 = 10K \text{ ohms}$$

APPENDIX A  
Supplementary Data

C. Find  $A_V$ .

$$A_V = \frac{V_{out}}{V_{in}}$$

$$A_R = \frac{R_O}{R_i} = \frac{5K}{10K} = 0.5$$

$$\text{or } = A_R \times A_i = 0.5 \times 199 = 99.5$$

D. Find  $A_P$ .

$$A_P = \frac{P_{out}}{P_{in}}$$

$$\text{or } = A_i^2 \times A_R = 199^2 \times 0.5 = 19,800.5$$

12. Substituting the values given here for those in figure 2-56, solve for  $A_i$ ,  $R_i$ ,  $A_V$ , and  $A_P$ . Disregard the value of  $R_1$  and  $h_{ib}$ .

$$\begin{aligned} R_1 &= 5K \\ R_2 &= 20K \\ R_E &= 2K \end{aligned}$$

$$\begin{aligned} \text{Beta} &= 60 \\ h_{ib} &= 25 \text{ ohms} \end{aligned}$$

A. Find  $A_i$ .

$$A_i = \text{gamma} = \text{beta} + 1 = 60 + 1 = 61$$

B. Find  $R_i$ .

$$R_i = \text{gamma} \times (h_{ib} + R_E) = 61 \times (25 + 2000) = 123,535 \text{ ohm}$$

C. Find  $A_V$ .

$$A_V = \frac{V_{out}}{V_{in}}$$

$$A_R = \frac{R_O}{R_i} = \frac{2000}{123K} = 0.016$$

$$\text{or } = A_R \times A_i = 0.016 \times 61 = 0.976$$

D. Find  $A_P$ .

$$A_P = \frac{P_{out}}{P_{in}}$$

$$\text{or } = A_R \times A_i^2 = 0.016 \times 61^2 = 59.536$$

Answers to Section 4 Work Problems.

1. For good bias stabilization, it is desirable to maintain the value of  $R_1$  and  $R_2$  low and maintain  $R_E = 0$ . (True or False)
2. The best method of stabilizing the base-emitter junction of a transistor is to use a diode in place of  $R_1$ .

3. The voltage drop across  $R_L$  is known as  $V_C$ . (True or False)
4. The base-emitter junction displays a negative temperature characteristic.
5. The value of  $h_{ie}$  (may or may not) be disregarded in approximating the value of the quiescent  $I_B$  when  $R_E = 0$  and  $R_1 = 10 \times h_{ie}$ .
6. The value of  $R_E$  (may or may not) be disregarded in approximating the value of the quiescent  $I_B$  when  $h_{ie} = 5K$ ,  $\beta = 40$ ,  $R_E = 500$  ohms, and  $V_{BB}$  is constant.
7. A thermistor that displays a negative temperature coefficient will (increase or decrease) in resistance as the temperature decreases.
8. What coefficient of thermistor would be necessary to replace  $R_2$  to obtain bias stabilization? (Positive or Negative)
9. What would be the quiescent collector voltage,  $V_C$ , of figure 3-27 at  $25^\circ C$  if  $R_L$  was increased to  $5K$  and all other values remained the same?

$$I_C = 2.28 \text{ ma}$$

$$V_{RL} = I_C \times R_L = 2.28 \times 5K = 11.4 \text{ volts}$$

$$V_C = V_{CC} - V_{RL} = -20 \text{ volts} - 11.4 \text{ volts} = -8.6 \text{ volts}$$

10. The capacitor,  $C_1$ , bypassing  $R_E$ , in figure 3-27, provides what function?  
Prevents degeneration of the a-c voltage.
11. When a resistor is placed in the emitter of a transistor for the sole purpose of providing temperature stabilization, it is called an emitter swamping resistor.
12. Substituting the values given here for those in figure 3-9, find  $V_{BE}$ ,  $I_C$ , and  $V_C$  at  $25^\circ C$ .

$$\begin{aligned} V_{CC} &= -30 \text{ volts} \\ R_1 &= 10 \text{ ohms} \\ R_2 &= 740 \text{ ohms} \end{aligned}$$

$$\begin{aligned} h_{ie} &= 2K \text{ at } 25^\circ C \\ \beta &= 25 \\ R_L &= 2K \end{aligned}$$

- A. Find  $V_{BE}$ .

$$V_{BE} = \left( \frac{V_{CC}}{R_1 + R_2} \right) \times R_1 = 0.4 \text{ volt}$$

- B. Find  $I_C$ .

$$I_C = \beta \times I_B = 25 \times 0.2 = 5 \text{ ma}$$

$$I_B = \frac{V_{BE}}{h_{ie}} = \frac{0.4}{2K} = 0.2 \text{ ma}$$

- C. Find  $V_C$ .

$$V_C = V_{CC} - V_{RL} = -30 - 10 = -20 \text{ volts}$$

$$V_{RL} = I_C \times R_L = 5 \text{ ma} \times 2K = 10 \text{ volts}$$

13. Using the values in problem 12, find  $V_{BE}$ ,  $I_C$ , and  $V_C$  at  $50^\circ C$  if  $h_{ie}$  equals  $1K$  at  $50^\circ C$ .

- A. Find  $V_{BE}$ .

$$\text{Same as 12A} - 0.4 \text{ volt}$$



APPENDIX A  
Supplementary Data

B. Find  $I_C$ .

$$I_C = \beta \times I_B = 25 \times 0.4 = 10 \text{ ma}$$

$$I_B = \frac{V_{BE}}{h_{ie}} = \frac{0.4}{1K} = 0.4 \text{ ma}$$

C. Find  $V_C$ .

$$V_C = V_{CC} - V_{RL} = -30 - 20 = -10 \text{ volts}$$

$$V_{RL} = I_C \times R_L = 10 \text{ ma} \times 2K = 20 \text{ volts}$$

14. Substituting the values given here for those in figure 3-40 and using the method of approximating, find  $V_{RE}$ ,  $I_C$ , and  $V_C$  ( $\beta$  and  $h_{ie}$  unknown).

$$V_{CC} = 24 \text{ volts}$$

$$R_1 = 2.3K$$

$$R_2 = 5.8K$$

$$R_E = 2K$$

$$R_L = 1.5K$$

A. Find  $V_{RE}$ .

$$V_{RE} = V_{BB} \text{ assuming } h_{ie} = 0$$

$$V_{BB} = \left( \frac{V_{CC}}{R_1 + R_2} \right) \times R_1 = \left( \frac{24}{8K} \right) \times 2.3K = 6 \text{ volts}$$

B. Find  $I_C$ .

$$I_C = \alpha \times I_E = 1 \times 3 = 3 \text{ ma}$$

$$I_E = \frac{V_{RE}}{R_E} = \frac{6 \text{ volts}}{2K} = 3 \text{ ma}$$

C. Find  $V_C$ .

$$V_C = V_{CC} - V_{RL} = 24 - 4.5 = -19.5 \text{ volts}$$

$$V_{RL} = I_C \times R_L = 3 \text{ ma} \times 1.5K = 4.5 \text{ volts}$$

Answers to Section 5 Work Problems.

1.  $I_{CBO}$  adds to the external  $I_B$ . (True or False)
2. For good bias stability, it is desirable to keep the value of  $R_E$  large and the value of  $R_1$  and  $R_2$  small.
3. If the change in  $I_{CBO}$  is known, the change in the emitter current can be found by multiplying  $S_i$  times the change in  $I_{CBO}$ .
4. Increasing the value of  $R_E$  of a circuit will cause the value of  $S_i$  to (increase or decrease).

5. Substituting the values given here for those in figure 3-84, find the quiescent  $V_{RE}$ ,  $I_C$ , and  $V_C$ . Also, find  $S_i$  and the change in  $V_C$ , and  $V_C$  due to the increase of  $I_{CBO}$ , from  $50^\circ\text{C}$  to  $75^\circ\text{C}$ . Assume  $h_{ie}$  constant and use approximate equations. Assume  $\alpha = 1$ .

$I_{CBO}$  at  $50^\circ\text{C}$  = 0.005 ma  
 $I_{CBO}$  at  $75^\circ\text{C}$  = 0.150 ma  
 Disregard  $h_{ie}$   
 $R_1 = 2.5\text{K}$

$R_2 = 5\text{K}$   
 $R_L = 1.5\text{K}$   
 $R_E = 1\text{K}$   
 $V_{CC} = -30$  volts

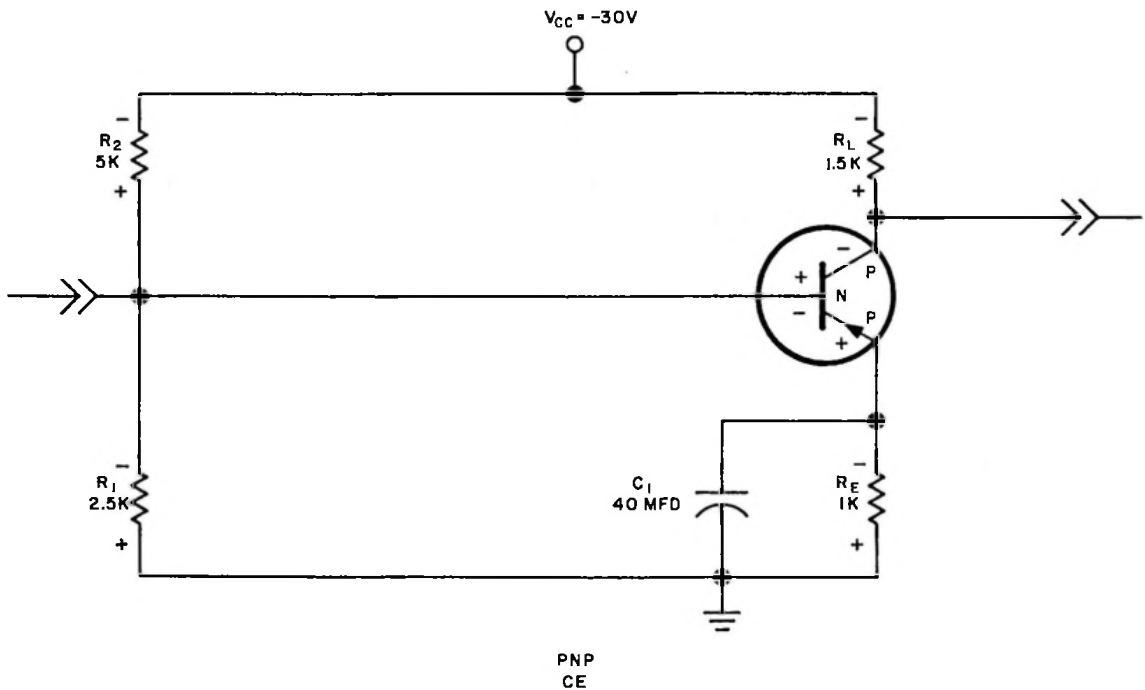

Figure A-3

- A. Find  $V_{RE}$  at  $50^\circ\text{C}$ . Disregard  $I_{CBO}$ .

$$V_{BB} = \frac{V_{CC}}{R_1 + R_2} \times R_1 = \frac{30}{2.5\text{K} + 5\text{K}} \times 2.5\text{K}$$

$$V_{BB} = -10 \text{ volts}$$

$$V_{BE} \approx 0$$

Therefore  $V_{RE} \approx V_{BB}$

$$V_{RE} = -10 \text{ volts}$$

- B. Find  $I_C$  at  $50^\circ\text{C}$ . Disregard  $I_{CBO}$ .

Assume  $\alpha = 1$

APPENDIX A  
Supplementary Data

$$I_E = I_C$$

$$I_E = \frac{V_{RE}}{R_E} = \frac{10}{1K}$$

$$I_E = 10 \text{ ma}$$

Therefore  $I_C \cong 10 \text{ ma}$

C. Find  $V_C$  at  $50^\circ\text{C}$ . Disregard  $I_{CBO}$ .

$$V_C = V_{CC} - V_{RL}$$

$$V_{RL} = I_C \times R_L = 10 \text{ ma} \times 1.5K$$

$$V_{RL} = 15 \text{ volts}$$

$$V_C = -30 - (15)$$

$$V_C = -15 \text{ volts}$$

D. Find  $S_i$

$$S_i = \frac{R_1}{R_E} + 1 = \frac{2.5K}{1K} + 1$$

$$S_i = 3.5$$

E. Find the change in  $I_C$  due to the change in  $I_{CBO}$ .

$$\Delta I_C = S_i \times \Delta I_{CBO}$$

$$\Delta I_{CBO} = 0.150 \text{ mc} - 0.005 \text{ ma}$$

$$\Delta I_{CBO} = 0.145 \text{ ma}$$

$$\Delta I_C = 3.5 \times 0.145 \text{ ma}$$

$$\Delta I_C = 0.5075 \text{ ma}$$

F. Find the change in  $V_C$  due to the change in  $I_{CBO}$ .

$$\Delta V_C = \Delta I_C \times R_L$$

$$\Delta V_C = 0.5075 \text{ ma} \times 1.5K$$

$$\Delta V_C = 0.76125 \text{ volts}$$

**Definitions.**

$A_{ib}$  . . . . . Current gain of a common base circuit.

$A_{ic}$  . . . . . Current gain of a common collector circuit.

$A_{ie}$  . . . . . Current gain of a common emitter circuit.

$A_p$	Power gain.
$A_{rb}$	Resistance gain of a common base circuit.
$A_{rc}$	Resistance gain of a common collector circuit.
$A_{re}$	Resistance gain of a common emitter circuit.
$A_{vb}$	Voltage gain of a common base circuit.
$A_{vc}$	Voltage gain of a common collector circuit.
$A_{ve}$	Voltage gain of a common emitter circuit.
$I_B$	Quiescent (d-c) base current.
$I_C$	Quiescent (d-c) collector current.
$I_{CBO} = I_{CO}$	Minority carrier current of the collector.
$I_E$	Quiescent (d-c) emitter current.
$I_b$	Operating (a-c) base current.
$I_c$	Operating (a-c) collector current.
$I_e$	Operating (a-c) emitter current.
$h_{fb}$	Forward current transfer ratio of a transistor in a common base configuration.
$h_{fc}$	Forward current transfer ratio of a transistor in a common collector configuration.
$h_{fe}$	Forward current transfer ratio of a transistor in a common emitter configuration.
$h_{ib}$	Input resistance of a transistor in a common base configuration.
$h_{ic}$	Input resistance of a transistor in a common collector configuration.
$h_{ie}$	Input resistance of a transistor in a common emitter configuration.
$h_{ob}$	Output conductance of a transistor in a common base configuration.
$h_{oc}$	Output conductance of a transistor in a common collector configuration.
$h_{oe}$	Output conductance of a transistor in a common emitter configuration.
$h_{rb}$	Reverse voltage transfer ratio of a transistor in a common base configuration.
$h_{rc}$	Reverse voltage transfer ratio of a transistor in a common collector configuration.
$h_{re}$	Reverse voltage ratio of a transistor in a common emitter configuration.
$R_{BE}$	Resistance base to emitter.
$R_{ib}$	Input impedance of a common base.

APPENDIX A  
Supplementary Data

$R_{ic}$	Input impedance of a common collector.
$R_{ie}$	Input impedance of a common emitter.
$R_{ob}$	Output resistance of a common base.
$R_{oc}$	Output resistance of a common collector.
$R_{oe}$	Output resistance of a common emitter.
$V_B$	Voltage at the base.
$V_{BB}$	Voltage of the base supply.
$V_{BE}$	Voltage base to emitter.
$V_C$	Collector voltage.
$V_{CB}$	Voltage collector to base.
$V_{CC}$	Voltage of the collector supply.
$V_{CE}$	Voltage collector to emitter.
$V_{R1}$	Voltage across $R_1$ .
$V_{R2}$	Voltage across $R_2$ .
$V_{RE}$	Voltage across $R_E$ .
$V_{RL}$	Voltage across $R_L$ .

Equations.

$$\text{Alpha} - A = h_{fb} = \frac{B}{1 + B}$$

$$\text{Beta} = B = h_{fe} = \frac{A}{1 - A}$$

$$\text{Gamma} = G = h_{fc} = B + 1$$

$$R_{ie} \cong \frac{R_1 + [h_{ie} + (G \times R_E)]}{R_1 \times [h_{ie} + (G \times R_E)]}$$

$$R_{ic} \cong R_{ie}$$

$$R_{ib} \cong \frac{R_E + h_{ib}}{R_E \times h_{ib}}$$

$$A_{ie} \cong \text{Beta}$$

$$A_{ic} \cong \text{Gamma}$$

$$A_{ib} \cong \text{Alpha}$$

$$A_{ve} = \text{Beta} \times A_R = \frac{V_{out}}{V_{in}}$$

$$A_{vc} = \text{Gamma} \times A_R = \frac{V_{out}}{V_{in}}$$

$$A_{vb} = \text{Alpha} \times A_R = \frac{V_{out}}{V_{in}}$$

$$A_R = \frac{R_{out}}{R_{in}}$$

$$A_{pe} = \text{Beta}^2 \times A_R = \frac{P_{out}}{P_{in}}$$

$$A_{pc} = \text{Gamma}^2 \times A_R = \frac{P_{out}}{P_{in}}$$

$$A_{pb} = \text{Alpha}^2 \times A_R = \frac{P_{out}}{P_{in}}$$

$$h_{ie} = \text{Gamma} \times h_{ib}$$

$$h_{ib} = \frac{H_{ie}}{\text{Gamma}}$$

$$I_c = B \times I_B = \text{Alpha} \times I_E$$

$$S_i = \frac{R_1}{R_E} + 1 \quad \text{Should be less than 10.}$$

$$S_i \times I_{CBO} = \Delta I_c \quad \text{Due to temperature.}$$

Lowercase letters always indicate a-c conditions, while uppercase letters indicate d-c conditions.

### Servicing Transistor Circuits.

#### 1. GENERAL.

Servicing procedures and test equipments that have been used in the past with other types of electronic equipment, for the most part, may be used with transistor circuits. Some special precautions which must be observed are listed below.

#### 2. TEST EQUIPMENT.

Damage to transistors by test equipment usually is the result of accidentally applying too much current or voltage to the transistor elements. Common causes of damage from test equipment are as follows.

APPENDIX A  
Supplementary Data

A. TRANSFORMERLESS POWER SUPPLIES.

Test equipment with transformerless power supply is one source of potentially damaging current. This type of test equipment can be used by employing an isolation transformer in the power line.

B. LINE FILTER.

It is still possible to damage transistors from line current if the test equipment is equipped with a line filter even though the test equipment has a power transformer in the power supply. This filter may act as a voltage divider and apply 55 volts a-c to the transistor. To eliminate trouble from this situation, connect a ground wire from the chassis of the test equipment to the chassis of equipment under test before making any other connections.

C. LOW SENSITIVITY MULTIMETERS.

Another cause of transistor damage is a multimeter that requires excessive current for adequate indication. Multimeters that have sensitivities of less than 5000 ohms per volt should not be used. A multimeter with lower sensitivity will draw too much current through many types of transistors and damage them. Use of 20,000-ohm-per-volt meters or vacuum-tube voltmeters is recommended. Check the ohmmeter circuits (even those in vtvm's) on all scales with an external, low resistance milliammeter in series with the ohmmeter leads. If the ohmmeter draws more than 1 milliampere on any range, this range cannot be used safely on small transistors.

3. ELECTRIC SOLDERING IRON.

The following are possible causes of transistor damage from soldering iron.

A. LEAKAGE CURRENT.

Electric soldering irons may damage transistors through leakage current. To check a soldering iron for leakage current, connect an a-c voltmeter between the top of the iron and a ground connection (water pipe or line ground), allow the iron to heat, then check for a-c voltage with the meter. Reverse the plug in the a-c receptacle, and again check for voltage. If there is any indication on the meter, isolate the iron from the a-c line with a transformer. The iron may be used without the isolation transformer if the iron is plugged in and brought to temperature, then unplugged for the soldering operation. It is also possible to use a ground wire between the tip of the iron and the chassis of the equipment being repaired to prevent damage from leakage current.

B. IRON SIZE.

Light-duty soldering irons of 20- to 25-watt capacity are adequate for transistor work and should be used. If it is necessary to use a heavier duty iron, wrap a piece of number 10 copper wire around the tip of the iron and make it extend beyond the tip of the iron. Tin the end of the piece of copper wire, and use it as the soldering tip.

4. SERVICING PRACTICES.

A. HEAT SINK WHEN SOLDERING.

When installing or removing a soldered-in transistor, grasp the lead to which heat is being applied between the solder joint and the transistor with long-nosed pliers to bleed off some of the heat that conducts into the transistor from the soldering iron. Make sure that the wires that are being soldered to transistor terminals are pretinned properly so that the connection can be made quickly. Excessive heat will damage a transistor permanently.

B. REMOVAL OF TRANSISTORS FROM OPERATING CIRCUITS.

Never remove or replace a plug-in transistor when the supply voltage is turned on. Transients thus produced may damage the transistor or others remaining in the circuit. If a transistor is to be evaluated in an external test circuit, be sure that no more voltage is applied to the transistor than normally is used in the circuit from which it came.

C. PLUG-IN TRANSISTORS.

When servicing equipment that uses plug-in transistors, it is good practice to remove the transistors from their sockets and reinsert them to break down any film of corrosion or dirt that may have formed.

D. RESISTANCE MEASUREMENTS IN TRANSISTOR CIRCUITS.

When measuring resistances of circuits containing transistors or mineral diodes, remember that these components are polarity and voltage conscious. Any capacitors used in transistor circuits usually are of large values (especially in audio, servo, or power circuits) and take time to charge when an ohmmeter is connected to a circuit in which they appear. Thus any reading obtained is subject to error if the capacitor is not allowed time to charge fully. In some cases, it may be best to isolate the components in question and measure them individually.

E. POWER TRANSISTOR HEAT SINKS.

In some cases, power transistors are mounted on heat sinks that are designed to carry heat away from them. In some power circuits, the transistor also must be insulated from ground. This insulating is done by means of insulating washers made of fiber and mica. When replacing transistors mounted in this manner, be sure that the insulating washers are replaced in proper order. Before installing the mica washers, treat them with a film of silicone fluid (Collins part number 005-0273-00 or equivalent). This treatment helps in the transfer of heat. After the transistor is mounted and before making any connections to it, check from the case to ground with an ohmmeter to see that the insulation is effective.

F. TEST PRODS.

Test prods should be clean and sharp. Because many of the resistors used in transistorized equipments have low values, any additional resistance produced by a dirty test prod will make a good resistor appear to be out of tolerance.

In miniaturized equipment, the clearance between socket terminals, wires, and other components usually is very small. It is a good practice to cover all of the exposed tip of the test prod, except about 1/8 inch, with plastic tape or other insulation.

5. TROUBLE SHOOTING.

The usual trouble-shooting practices apply to transistors. Be sure that equipment and tools meet the requirements outlined in the above paragraphs. It is recommended that transistor testers be used to evaluate the transistor.

If a transistor tester is not available, a good ohmmeter may be used for testing. Be sure the ohmmeter meets the requirements as set forth in the above paragraph on test equipment. To check a PNP transistor, connect the positive lead of the ohmmeter to the base and the negative lead to the emitter. (The red lead is not necessarily the positive lead on all ohmmeters.) Generally, a resistance reading of 50,000 ohms or more should be obtained. Connect the negative lead to the collector; again a reading of 50,000 ohms or more should be obtained. Reconnect the circuit with the negative lead of the ohmmeter to the base.

With the positive lead connected to the emitter, a value of resistance in the order of 500 ohms or less should be obtained. Likewise, with the positive lead connected to the collector, a value of 500 ohms or less should be obtained.

Similar tests made on an NPN transistor produce results as follows: with the negative ohmmeter lead connected to the base, the value of resistance between the base and the emitter and between the base and the collector should be high. With the positive lead on the ohmmeter connected to the base, the value of resistance between the base and the collector should be low. If the readings do not check out as indicated, the transistor probably is defective and should be replaced.

**CAUTION: IF A DEFECTIVE TRANSISTOR IS FOUND, MAKE SURE THAT THE CIRCUIT IS IN GOOD OPERATING ORDER BEFORE INSERTING THE REPLACEMENT TRANSISTOR. IF A SHORT CIRCUIT EXISTS IN THE CIRCUIT, PLUGGING IN ANOTHER TRANSISTOR MOST LIKELY WILL RESULT IN ANOTHER BURNED OUT TRANSISTOR. DO NOT DEPEND UPON FUSES TO PROTECT TRANSISTORS.**



APPENDIX A  
Supplementary Data

Make sure that the value of the bias resistors in series with the various transistor elements are as shown in the schematic diagram. The transistor is very sensitive to improper bias voltages. Therefore, a short or open circuit in the bias resistors may damage the transistor. For this reason, do not trouble shoot by shorting various points in the circuit to ground and listening for clicks.

**Summary.**

Because this is a new method of training on a relatively new electronic device, please submit your comments by filling out the following critique form and mailing it to the address indicated.

This particular course discussed the two-element device, the diode, and the three-element device, the transistor. Both devices were discussed only in the basic configuration, and no mention was made of semiconductor physics or special semiconductor devices. If sufficient interest is expressed by these critique forms, additional courses could be generated covering semiconductor physics, unijunction transistors, SCR's, tunnel diodes, pulse circuitry, oscillators, and audio and r-f amplifiers. In addition, any of these subjects could be treated from a design outlook, discussing the design parameters and details and equations necessary to correctly design operation and single and multistage circuits. The course that you have just completed was written to a technician's level and is not intended to explain design procedures, but only the general procedures for determining what a transistor or diode circuit that has been designed by someone else will do.

If you feel there is a need for any of the courses that are mentioned here, or any that are not mentioned that you would like to have presented in this manner, please indicate this.

## Course Critique Form

Was the course too long ?	YES	NO
COMMENT:		
Was the course too short ?	YES	NO
COMMENT:		
Was the material covered in enough detail ?	YES	NO
COMMENT:		
Was the material covered in too much detail ?	YES	NO
COMMENT:		
Were there enough illustrations ?	YES	NO
COMMENT:		
Were there too many illustrations ?	YES	NO
COMMENT:		
Were the illustrations legible ?	YES	NO
COMMENT:		
Were the tests sufficient ?	YES	NO
COMMENT:		
Were the tests too difficult ?	YES	NO
COMMENT:		
Were the tests too easy ?	YES	NO
COMMENT:		

APPENDIX A  
Supplementary Data

Was the written material sufficient?	YES	NO
COMMENT:		
Was the written material too detailed?	YES	NO
COMMENT:		
Was the written material supplied in enough detail?	YES	NO
COMMENT:		
Was the tape presentation slow enough?	YES	NO
COMMENT:		
Was the tape presentation fast enough?	YES	NO
COMMENT:		
Were there enough slides?	YES	NO
COMMENT:		
Were there too many slides?	YES	NO
COMMENT:		
Were the slides presented for a long enough time interval?	YES	NO
COMMENT:		
Were the slides presented for too long a time interval?	YES	NO
COMMENT:		
Were the slides legible?	YES	NO
COMMENT:		
Was there too much material on each slide?	YES	NO
COMMENT ?		



APPENDIX A  
Supplementary Data

Circle any of the following courses that you would like to see as a tape-slide presentation.

Semiconductor Physics	Pulse Circuits
Tunnel Diodes	A-F Amplifiers
SCR's	Oscillators
Unijunction Transistors	R-F Amplifiers

Design techniques on:

Others:

If you noted any errors, please list them below. Use additional sheets if necessary.

General comments on the course. Use additional sheets if necessary.

Send this critique form and any comments to

COLLINS RADIO COMPANY  
Training Supervisor  
Product Support Division Training Department  
321 Third Street S.E.  
Cedar Rapids, Iowa

ERRATA SHEET  
FUNDAMENTALS OF SEMICONDUCTORS

<u>Page</u>	<u>Figure/Paragraph</u>	<u>Corrections</u>
1-13	1-41	C1 should be 60 ufd
1-18	1-62	C1 should be 60 ufd
2-5	2-15	$V_{CC}$ should be +20v
2-8	2-23	Ap should be equal to $\frac{9.025}{0.1} - 90.25$
2-12	2-35	Ap should be equal to $\frac{9.025}{0.1} = 90.25$
3-13	Right Column, Para. 2	Zero degree absolute is 450° below zero fahrenheit
A-5	Question 11	<u>dis</u> regard the value . . . . .
A-8	Question 14A	$= \frac{24}{8K} \times 2K = 6$ volts

This manual is designed to be used with the slide/tape transistor program which is available from the Sales Department in Cedar Rapids.

