

**extel**®

SERIES AE AND AF  
TELEPRINTERS

Installation and Operation Manual

**extel** CORPORATION

310 Anthony Trail

Northbrook, Illinois 60062

Telephone: (312) 564-2600

Telex: 72-4398



SERIES AE AND AF  
TELEPRINTERS

Installation and Operation Manual

Extel Corporation  
310 Anthony Trail  
Northbrook, Illinois 60062 USA

Telephone: (312) 564-2600-<sup>291-2500</sup>  
Telex: 72-4398

PROPRIETARY STATEMENT

This manual contains proprietary information of Extel Corporation and is not to be used, reproduced or disclosed without express written permission, except for the purpose intended.

Copyright © Extel Corporation, 1975



Extel Corporation  
WARRANTY

The Manufacturer warrants that the products to be delivered under this purchase order will be free from defects in material and workmanship under normal use and service. Manufacturer's obligation under this warranty are limited to replacing or repairing or giving credit for, at its option, at its factory, any of said products which shall, within one (1) year after manufactured, be returned to the Manufacturer's factory of origin, transportation charges prepaid, and which are, after examination, disclosed to the Manufacturer's satisfaction to be thus defective. THIS WARRANTY IS EXPRESSED IN LIEU OF ALL OTHER WARRANTIES, EXPRESSED, STATUTORY, OR IMPLIED, INCLUDING THE IMPLIED WARRANTY OF FITNESS FOR A PARTICULAR PURPOSE, AND OF ALL OTHER OBLIGATIONS OR LIABILITIES ON THE MANUFACTURER'S PART, AND IT NEITHER ASSUMES NOR AUTHORIZES ANY OTHER PERSON TO ASSUME FOR THE MANUFACTURER ANY OTHER LIABILITIES IN CONNECTION WITH THE SALE OF THE SAID ARTICLES.

This Warranty shall not apply to any of such products which shall have been repaired or altered, except by the Manufacturer, or which shall have been subjected to misuse, negligence, or accident. The aforementioned provisions do not extend the original warranty periods of any product which has either been repaired or replaced by Manufacturer.



## CONTENTS

SECTION	PAGE
1. INTRODUCTION	
1-1. General Description . . . . .	1-1
1-2. Principles of Operation. . . . .	1-2
a. Character Printing and Spacing . . . . .	1-2
b. Paper Feed Drive Mechanism. . . . .	1-2
c. Carriage Return . . . . .	1-3
1-3. Special Features . . . . .	1-4
a. Bell . . . . .	1-4
b. Last Character Visibility (LCV). . . . .	1-4
c. Rail Monitor Switch . . . . .	1-4
d. Full Monitor Switch . . . . .	1-4
1-4. Teleprinter Code Reception . . . . .	1-5
1-5. Characteristics and Specifications. . . . .	1-6
a. Model Designations . . . . .	1-6
b. Printing Characteristics. . . . .	1-7
c. Paper Specifications . . . . .	1-7
d. General Specifications. . . . .	1-7
1-6. Available Options . . . . .	1-8
a. Sensor Unit for Low Paper Alarm . . . . .	1-8
b. Selective Calling . . . . .	1-9
c. Single/Double Line Feed Switch . . . . .	1-9
d. Paperwinder . . . . .	1-9
e. Pedestal Stand . . . . .	1-9
f. Emergency Broadcast System (EBS) Relay Option . . . . .	1-10
g. Dual-Primary Transformer. . . . .	1-10
1-7. Conversion Kits . . . . .	1-10
a. Ribbon Conversion Kit . . . . .	1-10
b. Emergency Broadcast System (EBS) Conversion Kit. . . . .	1-11
c. 74-Character to 69-Character Line Conversion Kit . . . . .	1-11
d. 69-Character to 74-Character Line Conversion Kit . . . . .	1-11
e. 74-Character to 80-Character Line Conversion Kit . . . . .	1-11
f. 80-Character to 74-Character Line Conversion Kit . . . . .	1-11
g. 8½-inch to 6-inch Paper Conversion Kit. . . . .	1-11
h. 6-inch to 8½-inch Paper Conversion Kit. . . . .	1-11



## 2. INSTALLATION

2-1. General .....	2-1
2-2. Unpacking and Inspecting .....	2-1
2-3. Installation Location .....	2-2
2-4. Controls and Indicators .....	2-2
a. Power ON/OFF Switch .....	2-2
b. Power-On Lamp .....	2-3
c. Circuit Alarm Lamp .....	2-3
d. Speed Control Switch .....	2-3
2-5. Power Interface .....	2-3
a. General .....	2-3
b. Operating Voltages .....	2-4
c. Dual-Primary Transformer .....	2-5
2-6. Signal Interface .....	2-6
a. Neutral/Polar/Audio Lines .....	2-6
b. RS-232-C (EIA) Interface .....	2-8
2-7. Operating Frequencies .....	2-9
2-8. Paper Roll Bracket .....	2-10
2-9. Sensor Unit for Low Paper Alarm .....	2-12
2-10. Logic Board Programming Options .....	2-13
2-11. Internal Access .....	2-15
a. To Remove Teleprinter Cover .....	2-15
b. To Gain Access to Printed Circuit Board Assemblies .....	2-16
2-12. Paperwinder Installation .....	2-18
2-13. Systems Integration Block Diagram .....	2-19

## 3. OPERATION

3-1. General .....	3-1
3-2. Paper Installation .....	3-1
a. Types of Paper .....	3-1
b. Paper Loading .....	3-2
c. Removal of Paper from Paperwinder .....	3-4



- 3-3. Ribbon Installation ..... 3-5
- 3-4. Message Removal ..... 3-7
  - a. Single-Copy Paper ..... 3-7
  - b. Multi-Copy Paper ..... 3-7
- 3-5. Control Switches ..... 3-8
  - a. Line Feed Switch ..... 3-8
  - b. Speed Switch ..... 3-8
  - c. Full Monitor Switch ..... 3-9
  - d. Rail Monitor Switch ..... 3-9
  - e. Last Character Visibility (LCV) Switch ..... 3-9
- 3-6. Operator-Level Maintenance. .... 3-9

4. OPTIONS

- 4-1. Emergency Broadcast System (EBS) Relay Option. .... 4-1
- 4-2. 7305 Selective Calling Programming ..... 4-2



## SECTION 1

### Introduction

#### 1-1. GENERAL DESCRIPTION

Series AE and AF teleprinters are solid-state, electronic, receive-only units that provide a 5 x 7 dot matrix printout upon receipt of serialized data from appropriate transmission sources. The units are designed for continuous or intermittent-duty applications, and are capable of printing asynchronously at all speeds up to 15 characters per second. Their very low operating noise level and high degree of reliability is the product of a design philosophy which combines a simple, reliable printing mechanism with advanced electronic control circuitry.

Series AE and AF teleprinters are designed to operate from either a 115 VAC or 230 VAC, 50/60 Hz., power source. (400 Hz. operation is available on special request.) The AE series of teleprinters employs a 50 character-per-line format, using 6-inch wide pressure-sensitive (ink-encapsulated) paper. The AF teleprinter series is capable of accepting either 50, 69, 74, or 80 character-per-line formats on 8½-inch wide paper. Units equipped with **Ribbon Mechanisms** use standard 8½-inch wide teleprinter paper, while **Non-Ribbon** machines employ pressure-sensitive (ink-encapsulated) paper. In addition, all machines are capable of accepting up to three-ply paper thickness.

Modular construction, used throughout the machine, facilitates easy access to electronic and mechanical assemblies, while providing versatile component interchangeability. The teleprinter cover has a hinged lid which provides ready access to the typing unit for paper and ribbon threading. A window, integral to the hinged lid, permits viewing of the printed copy during data reception, while also providing a convenient cutting edge to remove completed messages from the machine.

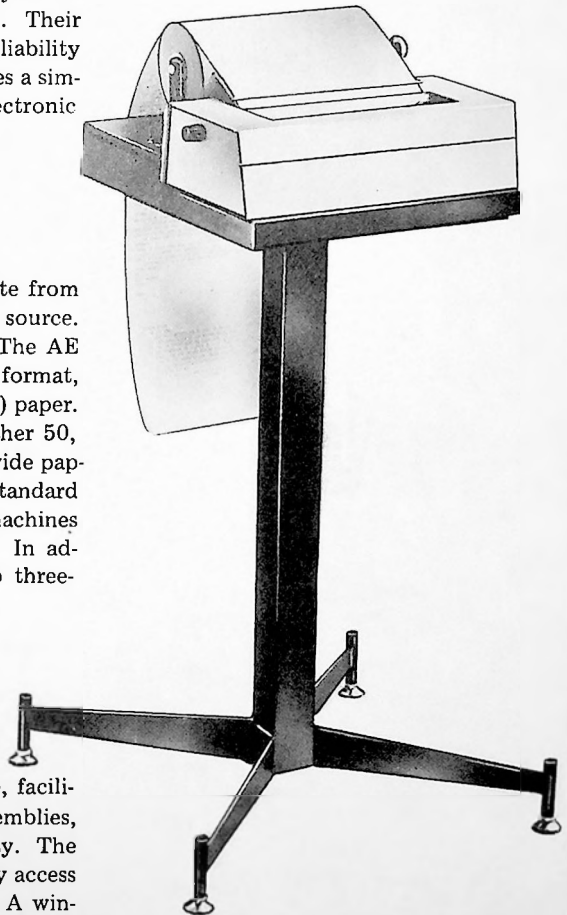

## 1-2. PRINCIPLES OF OPERATION

The following is a general discussion of the basic principles of operation. A more detailed analysis of the teleprinter's operational theory is contained in subsequent sections of this manual and the Service Manual for AE and AF Teleprinters.

### a. Character Printing and Spacing

Printing is achieved by the electronic activation of seven needles which are vertically mounted in the carriage assembly. A special stepper motor, the impulses to which are also derived from the electronic circuitry within the unit, powers the carriage assembly across the platen. The carriage assembly moves eight steps for each character printed—three steps provide the spacing between characters, and the remaining five steps are used to print the 5 x 7 dot-matrix character pattern, as illustrated in Figure 1-1.

Stepper motors are also used to control the line feed function and ribbon movement of the teleprinter. The spacing mechanism, comprised of the above-mentioned spacing drive stepper motor, pulley, drive belt, drive pawl, and associated gears and capstans, laterally positions the carriage assembly so that the characters are properly located horizontally on the paper. This mechanism is activated each time a character or space is called for in the received code. Internal logic suppresses the carriage spacing action when certain "function" characters are received by the teleprinter.

### b. Paper Feed Drive Mechanism

The Paper Feed Drive Mechanism, comprised of a paper feed drive stepper motor, pulleys, drive belt and platen, positions the paper vertically so that spacing between the printed lines is of constant dimension. Four lines per inch are normally printed when the unit is functioning in the Single-line Feed mode. Upon receipt of a "line feed" encoded character, the Paper Feed Drive Mechanism will advance the paper vertically to the next line position.

If specified at the time of ordering, AE and AF series teleprinters will be equipped with a Line Feed Selector Switch. This is either a two- or three-position toggle switch located under the front of the unit. The two-position switch will offer selection of either single- or double line feed, or single-1½-line feed, operation. The three-position switch allows selection of single-, 1½- or double-line feed functions.

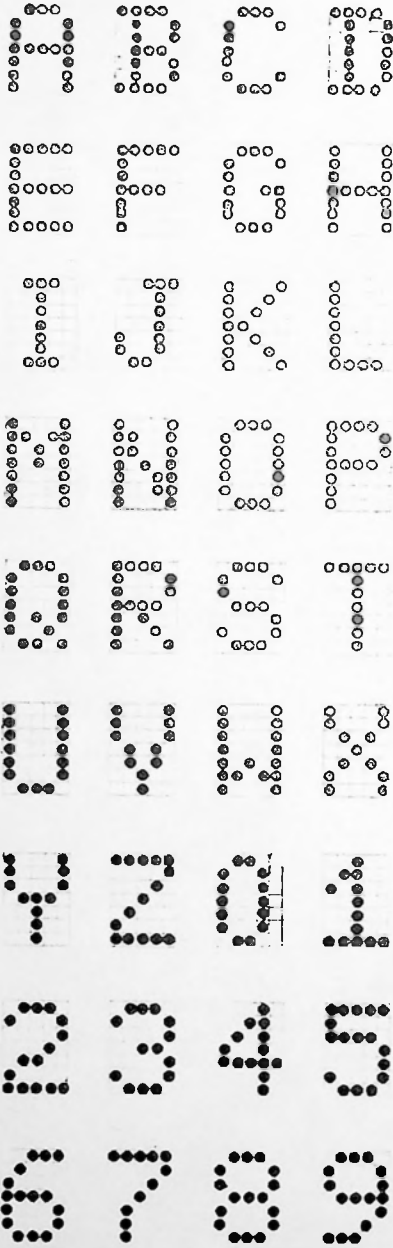

Figure 1-1. Dot Matrix Character Formation





## c. Carriage Return

The carriage return action is performed by the spacing drive stepper motor, located at the rear right-hand side of the typing unit assembly, together with gears and drive belts. When the spacing drive stepper motor is driven in reverse, the idler gear disengages from the right-hand capstan, permitting the force of the carriage return spring to return the carriage to the left side of the platen. Upon receipt of a "carriage return" encoded character, the teleprinter's control circuitry causes the spacing drive stepper motor to reverse, thus releasing the idler gear and allowing the carriage return spring to pull the carriage to the left-hand margin to begin a new line of print. A Decelerator, which is an inertia device (Shown in Figure 1-2.), cushions the carriage assembly as it reaches the left side of the platen. In most instances, the "carriage return" function is performed coincidental with the "line feed" function, so that the paper will be advanced vertically when the carriage is returned to begin a new line.

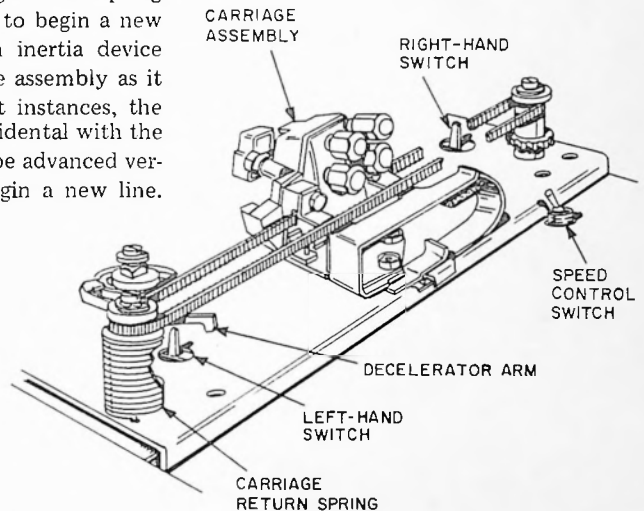

Figure 1-2. Typing Unit Component Identification

In Series AE and AF teleprinters, left margin and right margin switches are used to signal the unit's control circuitry as to when the carriage assembly has reached either the extreme right-hand or left-hand margin. Once the carriage has been returned to the left side of the platen, the Left Margin Switch signals the internal logic that the carriage is again ready for printing a new line. If, for any reason, the unit does not receive a "carriage return" encoded character, and the carriage assembly is allowed to reach its maximum predetermined excursion across the platen (i.e. for 50-, 69-, 74- or 80-character lines), the Right Margin Switch is activated, causing the carriage assembly to be returned automatically. These switches can be seen in Figure 1-2.



March 1, 1975

### 1-3. SPECIAL FEATURES

#### a. Bell

When received, the "Bell" encoded character activates a bell which provides the operator with an audible signal, useful for identifying at a distance information which is about to, or did, move on the wire. If an EBS (Emergency Broadcasting System) option is installed on your particular machine, the external alarm circuitry is also activated with the bell.

#### b. Last Character Visibility (LCV)

Teleprinters equipped to receive Six-Level (Teletypesetter) Code, and certain other specially-equipped units, contain this feature. If a pause in the incoming data causes the carriage to stop printing for more than one second, a special interval line feed causes the paper to be advanced upward. This aids considerably in viewing the last characters printed. When incoming traffic resumes, the platen then retracts the paper to its original position and printing continues where it had previously stopped. Section 3 shows the location of the switch which controls this feature.

#### c. Rail Monitor Switch

Six-Level (Teletypesetter) machines also feature a switch which allows the operator to monitor the Rail Shift symbols. When this switch is turned on, the unit will print unique symbols for "upper" and "lower" rail. Location of this switch is shown in Section 3 of this manual.

#### d. Full Monitor Switch

On Six-Level (Teletypesetter) machines it is often more desirable to have the teleprinter print out the symbols for all functions, while performing all functions except "carriage return" and "line feed". While in this Full Monitor Mode, the unit will print the unique symbols for "carriage return" and "line feed", but will not execute these mechanical operations at the time they are called for in the text. Rather, the teleprinter will completely fill each line with the maximum number of characters permitted and then automatically perform a "carriage return" and "line feed". This mode of operation is most useful in providing compact copy and greater



utilization of total printing area on the paper. Section 3 of this manual shows the position of the Full Monitor Switch on the teleprinter.

#### 1-4. TELEPRINTER CODE RECEPTION

Transmitted messages to the teleprinter are received in the form of an on/off signaling code. These on/off pulses are sent on-line, and follow each other in rapid succession (i.e. Serialized Data or Serial Data) according to a specified signaling code arrangement. Current widely-used codes contain either 5, 6 or 8 on/off bits to signify a given character or function. The teleprinter's logic circuitry must decode these 5-, 6- or 8-bit sequences to produce an intelligible printout. Standard codes that can be accepted by various units in the AE and AF Series of teleprinters are:

5-Level (Murray), US-A	CCITT No. 2
US-B	with £ Sign
US-C	

6-Level (Teletypesetter)

8-Level (ASCII)	CCITT No. 5
-----------------	-------------

**NOTE:** Other codes are available upon request.

In the reception of a code, each character and function is represented by a series of current or no-current time intervals when operating on a **Neutral DC Current Loop**. On this type of line, current flowing on the line is referred to as a **Mark**, while a no-current condition is termed a **Space**. In an **Audio Communications System**, a shift in the frequency of the tone on the line determines a **Mark** or **Space** condition. **Polar DC Current** systems have current flowing in one direction for a **Mark** condition and current flowing in the reverse direction to indicate a **Space** condition.

One of the principle codes used by the telecommunications industry is the CCITT No. 2 Code (5-Level). When receiving CCITT No. 2 encoded characters, each character or function is defined by at least 7 "on/off" units—one start pulse, one stop pulse, and five units (or levels) which determine the specific character or function. Figure 1-3 illustrates the transmitted character "E" using this code. The stop and start

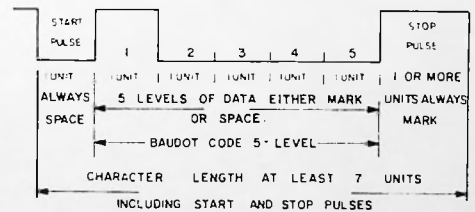

Figure 1-3. Five-Level Character "E" Representation



pulses are used to synchronize message reception with the transmitting site, allowing the receiver to know when a character begins and ends.

With five levels (or bits) available for defining characters and functions, the CCITT No. 2 Code can basically accommodate only 32 permutations. However, by utilizing the "Letters" and "Figures" shift, it is possible to double the effective complement of characters and/or functions to 64.

CCITT No.5 is a so-called 8-Level code, of which the American ASCII Code is a variation. This code can accommodate a larger number of unique characters and functions. Again, stop and start pulses are used for synchronizing the message, but this code uses eight bits (or levels) to define a character or function—bits 1-7 delineate the character, while the eighth bit is used for parity. Thus, with seven levels of mark or space information available, the CCITT No.5 Code can accommodate 128 permutations. In general, of these possibilities, 96 are assigned to printing characters, while the rest are devoted to non-printing (or function) characters or are unassigned. Figure 1-4 is a pictorial representation of the character "E" as defined in the 8-Level CCITT No.5 Code.

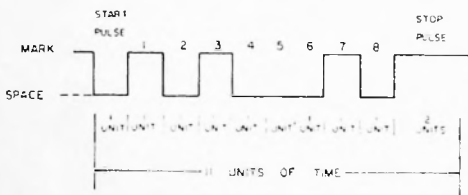

Figure 1-4. Eight-Level Character "E" Representation

## 1-5. CHARACTERISTICS AND SPECIFICATIONS

### a. MODEL DESIGNATIONS

MODEL	RIBBON MECHANISM	NO. OF CHARACTERS/LINE	PAPER SIZE
AE	NO	50	6-inch wide paper (152 mm wide) 8½-inch wide paper (216 mm wide) OR 210 mm wide paper
AF	NO	50, 69, 74, or 80	
AFR	YES	50, 69, 74, or 80	
AFL	NO*	50, 69, 74, or 80	

\* OPTIONAL (May be Field Installed)



b. PRINTING CHARACTERISTICS

Printing Method .....	5 x 7 Dot Matrix- Character by Character
Horizontal Spacing .....	10 Characters per Inch
Vertical Spacing .....	Four Lines per Inch (Single Line Feed)
Printing Rate .....	A "Speed Control" switch provides a choice of high or low operating speeds up to 15 characters per second.
Available Codes .....	CCITT No.2 (5-Level), CCITT No.5 [8-Level (ASCII)], 6-Level (Teletypesetter). Other codes available on request.

c. PAPER SPECIFICATIONS

Standard Teleprinter Paper .....	Ribbon Teleprinters
Pressure-Sensitive (Ink-Encapsulated) .....	Non-Ribbon Teleprinters
Single-Ply .....	For Single Copy Requirements
Up to 3-Ply .....	For Multiple Copy Requirements

d. GENERAL SPECIFICATIONS

Duty Cycle .....	Continuous or Intermittent Duty
Input Voltage .....	115 VAC or 230 VAC (Single Phase), 50/60 Hz. (400 Hz operation available on request)
Signal Line Input .....	GENERAL: Signal termination isolated from ground and other circuitry, unless otherwise specified. Isolation: 2500 volts DC. Standard series resistance: approxi- mately 70 ohms, unless otherwise specified. Other inputs available to conform to specific customer requirements.  D.C. INPUT: Neutral: 10-80 ma., Polar: 20-60 ma., or EIA standard interface RS-232-C.



March 1, 1975

Signal Line Input (Continued) . . . . .	AUDIO SIGNAL INPUT: Narrow-Band Audio Frequency Shift Keying (FSK), CCITT standard channel spacing available. Also compatible with Bell System or equivalent Dataset 103, 108, 109 or 113.
Input Impedance . . . . .	U.S.—70 ohms approx., U.K.—4K ohms approx., West Germany—240 ohms approx.
DC Distortion . . . . .	Teleprinter will accept up to 40% marking or spacing distortion at any operating speed.
Audio Distortion . . . . .	Teleprinter will accept up to 25% marking or spacing distortion at any operating speed.
Power Consumption . . . . .	60 Watts Maximum while printing. 25 Watts Maximum in standby condition.
Operating Temperature . . . . .	+32°F to +110°F at altitudes from mean sea level to 10,000 feet above mean sea level.
Dimensions and Weight (Without Paper Roll)	MODEL AE: 5" high, 15½" deep, 10¼" wide, 17 lbs.  MODEL AF: 5" high, 17¾" deep, 12 5/8" wide, 25 lbs.
Mounting . . . . .	Desk-top surface or Pedestal Stand (available in 28" and 36" heights.)

**1-6. AVAILABLE OPTIONS****a. SENSOR UNIT FOR LOW PAPER ALARM**

This feature can be connected by the customer to activate an external visual or audible alarm to signify that the paper roll supply is nearly exhausted. In Selective Calling applications, this feature can be used to alert the transmitting station that the teleprinter is not ready for message reception because of its inadequate paper supply. On units equipped with the EIA interface, the Sensor Unit performs a similar function.



**b. SELECTIVE CALLING**

This option, which must be specified at the time of ordering the machine, permits individual station selection on a common communications loop. In addition, a single-character Answerback may be provided in the Selective Calling network. If your machine has this option, refer to the Options Section of this manual for complete details.

**c. SINGLE/DOUBLE LINE FEED SWITCH**

This option consists of a small toggle switch, conveniently located in the lower left-hand corner under the teleprinter base, which allows the operator to choose either single- or double-line feed operation. Use and location of this switch is described in more detail in Section 3 of this manual.

**d. PAPERWINDER**

This device, which mounts on the rear of the teleprinter, retains all received messages on a continuous roll. It may be added as an accessory at some later date; or, if ordered with your particular machine, it will be sent separately and must be attached to the teleprinter by the installing technician. Figure 1-5 illustrates the Paperwinder assembly, and complete details for installing it are given in Section 2.

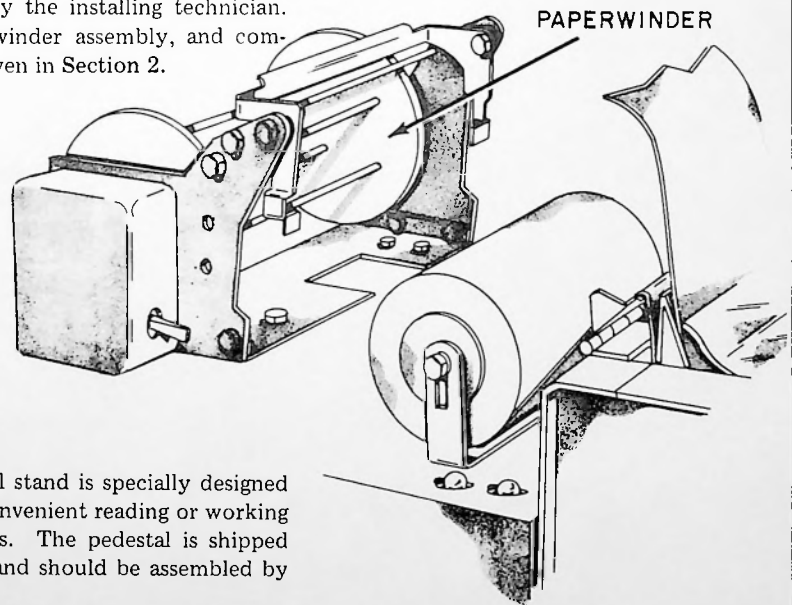
**e. PEDESTAL STAND**

This sturdily-constructed pedestal stand is specially designed to support the teleprinter at a convenient reading or working height of either 28 or 36 inches. The pedestal is shipped separately from the teleprinter, and should be assembled by the installing service personnel.

Figure 1-5. Paperwinder Assembly



March 1, 1975

#### f. EMERGENCY BROADCAST SYSTEM (EBS) RELAY OPTION

The EBS Relay Option provides the user with a normally open pair of contacts which function merely as a line closure, suitable for wiring in series with some external signaling device, such as a bell, horn or light. If the EBS Option was requested at the time of ordering your machine, your unit has been equipped with a special transformer assembly which includes a socket for accepting an EBS relay. This relay, and a barrier strip for mounting on the outside of the teleprinter cabinet, are shipped separately from the machine and must be installed by a qualified servicing technician.

#### g. DUAL-PRIMARY TRANSFORMER

As a factory-installed option which must be specified at the time of ordering, Series AF teleprinters can be equipped with a Dual-Primary Transformer in the power supply. This option permits the user to change the operating voltage from 230 VAC to 115 VAC, or visa versa.

### 1-7. CONVERSION KITS

The following is a list of Conversion Kits which are available for your Series AE or AF teleprinter. These kits are suitable for installation at some future date, should certain requirements for your machine change. Only qualified servicing personnel should install these Conversion Kits.

#### a. RIBBON CONVERSION KIT

This kit is used when it is desirable to change a Non-ribbon teleprinter to one utilizing a Ribbon Mechanism.

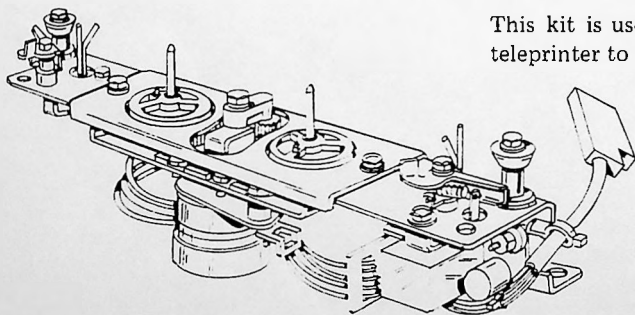

Figure 1-6. Ribbon Mechanism





March 1, 1975

**b. EMERGENCY BROADCAST SYSTEM (EBS)  
CONVERSION KIT**

This kit allows for the modification of the transformer assembly to accept an EBS relay and its associated barrier strip for connecting a remote alarm device to the teleprinter. This device would then be activated every time the bell rings.

**c. 74-CHARACTER TO 69-CHARACTER LINE  
CONVERSION KIT**

This kit allows a Model AF teleprinter, previously equipped for printing a 74-character line format, to be converted for 69-character-per-line use.

**d. 69-CHARACTER TO 74-CHARACTER LINE  
CONVERSION KIT**

This kit allows a Model AF teleprinter, previously equipped for printing a 69-character line format, to be converted for 74-character-per-line use.

**e. 74-CHARACTER TO 80-CHARACTER LINE  
CONVERSION KIT**

This kit allows a Model AF teleprinter, previously equipped for printing a 74-character line format, to be converted for 80-character-per-line use.

**f. 80-CHARACTER TO 74-CHARACTER LINE  
CONVERSION KIT**

This kit allows a Model AF teleprinter, previously equipped for printing an 80-character line format, to be converted for 74-character-per-line use.

**g. 8½-INCH TO 6-INCH PAPER CONVERSION KIT**

This kit allows a Model AF teleprinter, previously equipped to use 8½-inch wide paper, to be converted to accept 6-inch wide paper rolls.

**h. 6-INCH TO 8½-INCH PAPER CONVERSION KIT**

This kit allows a Model AF teleprinter, previously equipped to use 6-inch wide paper, to be converted to accept 8½-inch wide paper rolls.



## SECTION 2 Installation

March 1, 1975

### 2-1. GENERAL

This section provides instructions for installing your Series AE or AF teleprinter. Be certain to follow all "NOTES" and "CAUTIONS" described in the following pages, as they are provided for your safety and for the protection of your machine.

When reference is made to the physical location of various component parts, the teleprinter is considered to be viewed from the front of the unit—or operator's position—unless otherwise specified. No special tools are required to correctly install the unit.

### 2-2. UNPACKING AND INSPECTING

When removing the unit from its shipping carton, all instructions and CAUTIONS which may appear on the outside of the shipping container should be observed.

The unit is enclosed in a protective, dust-proof plastic bag which is surrounded by a shock-absorbing material. This packaging material, including the carton itself, should be saved in the event the unit must be returned or forwarded. Figure 2-1 illustrates the correct sequence for re-packaging the teleprinter for storage or re-shipping. When removed, the unit should be thoroughly inspected for any damage which might have occurred while the machine was in transit. If any damage is evident, it should be immediately reported to the transportation company.

#### NOTE

If the teleprinter is not to be put into operation until some future time, re-package the unit, using the original packing materials. Storage temperatures may range from 32°F to 150°F at altitudes up to 10,000 feet above mean sea level.

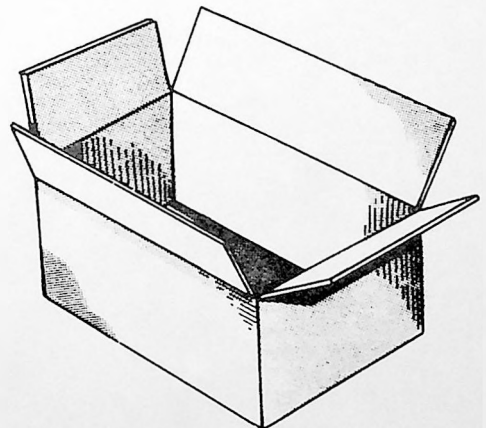
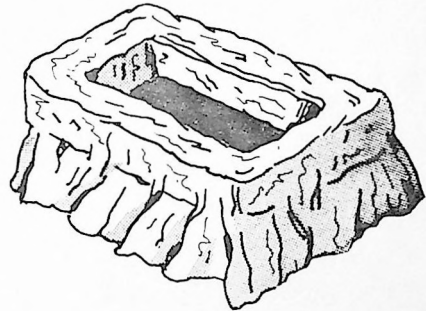
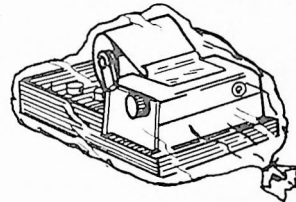
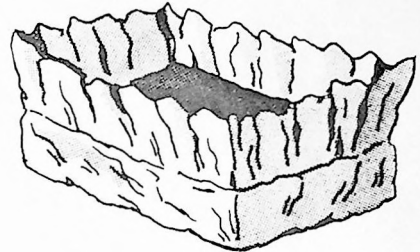

Figure 2-1. Packaging Sequence



### 2-3. INSTALLATION LOCATION

Since Series AE and AF teleprinters have an unusually low operating noise level, they may be installed without special enclosures or sound-absorbing material. In fact, it is NOT recommended that any padding or cushioning material be placed under the unit, as this could constrict air flow through the ventilation ports located underneath the machine.

The unit may be installed on any solid, level surface of sufficient area to accommodate the physical dimensions of the machine, but should not be situated in a room where the ambient temperature is likely to exceed 45°C (113°F) while the teleprinter is in operation. Likewise, it is not advisable to locate the unit within very close proximity to sources of direct heat, such as radiators or heating ducts.

The teleprinter may also be installed on its own specially-designed pedestal stand which provides proper ventilation for the unit, while supporting the teleprinter at a convenient working height.

In addition, the placement of the teleprinter should be convenient to an AC power source and data terminal facility. Data reception may be provided via appropriate transmission means, including telegraph lines, telephone networks or radio channels.

### 2-4. CONTROLS AND INDICATORS

#### a. POWER ON/OFF SWITCH

Figure 2-2 shows the location of the Power ON/OFF Switch on the Rear Bracket Assembly. This switch will be one of two varieties—either a red-handle type, mounted such that the upward position of the handle denotes the “ON” position and the downward position signifies “OFF”; or a black-handle type, mounted in such a way that the handle must be moved laterally for the “ON” and “OFF” positions.

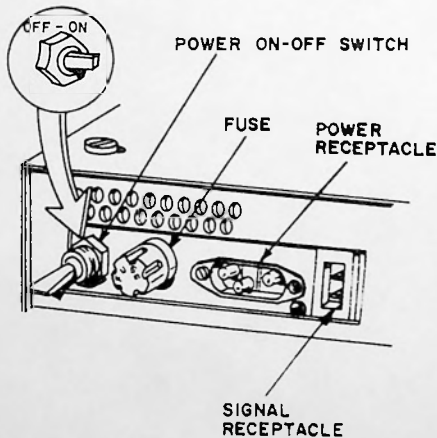

Figure 2-2. Rear Bracket Assembly (Typical)



b. POWER-ON LAMP

When the teleprinter is connected to an AC power source and the power switch has been turned "ON", a GREEN lamp adjacent to the left-hand side of the Paper Roll Bracket will light. This lamp will remain lit as long as the machine is "ON". See Figure 2-3 for its location.

c. CIRCUIT ALARM LAMP

When the teleprinter is connected to one of the various possible incoming signal sources—and a signal is present—this RED lamp next to the Power-ON lamp will blink ON and OFF in direct relationship to "mark" and "space" conditions on the line. Thus, under normal operating conditions, this lamp DOES NOT REMAIN LIT. If, however, there is a faulty signal line connection to the teleprinter, or, if for some reason normal signals are not present, the RED Circuit Alarm Lamp will remain lit continuously until the proper signal returns. See Figure 2-3.

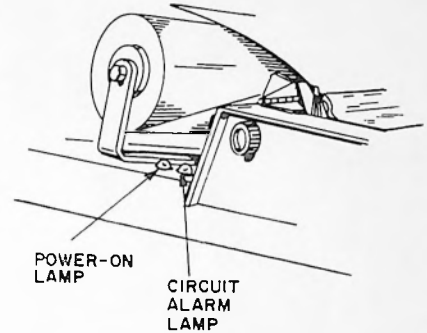

Figure 2-3. Indicator Lamps

d. SPEED CONTROL SWITCH

As described later in this section, this switch is located under the teleprinter cover. The switch selects either of two crystals installed in the machine which control the speeds at which the unit is capable of operating. The frequencies of the crystals installed in your machine have a direct relationship to applicable baud rates, and the specific crystals in your machine were specified at the time of ordering. See paragraph 2-7 in this section for further information.

2-5. POWER INTERFACE

a. GENERAL

Series AE and AF teleprinters are equipped with either a detachable or "hard-wired" power cord which is six (6) feet in length and meets the electrical specifications of the geographical area in which the unit is to be operated. One end of the detachable variety is normally terminated in a three-

*CAUTION*

Before making any power or signal line connections, place the Power Switch (Shown in Figure 2-2) in the OFF position.



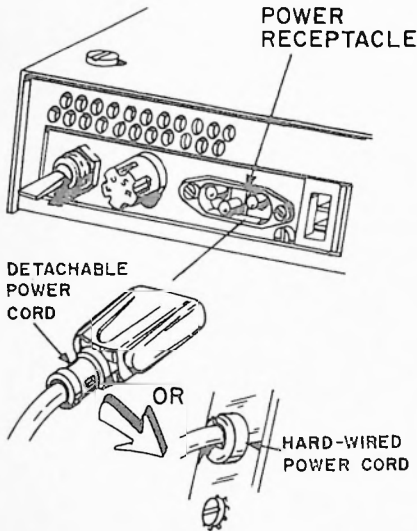

Figure 2-4. AC Power Connection to Teleprinter

prong male plug (as shown in Figure 2-5) for connection to an external AC power source which meets the specifications outlined on the model data plate affixed to the right-hand side of the machine. The molded female connector at the opposite end of the cord (as shown in Figure 2-4) connects to the power input receptacle which is part of the teleprinter's Rear Bracket Assembly.

Figure 2-4 also illustrates the alternate "hard-wired" power cord configuration which is permanently attached to the Rear Bracket Assembly. This version may or may not be terminated with a plug for connection to an appropriate AC power receptacle. In those cases where no plug is provided, the power cord will be terminated only with three stripped wires (as shown in Figure 2-5) and the installer must provide a plug of proper configuration for connection to power receptacles in the user's area.

b. OPERATING VOLTAGES

Your machine has been wired to operate from either a 115 VAC OR a 230 VAC power source, 50/60 Hz. Check the Status Card attached to the machine to ensure that it has been wired to meet the voltage requirements of your particular area.

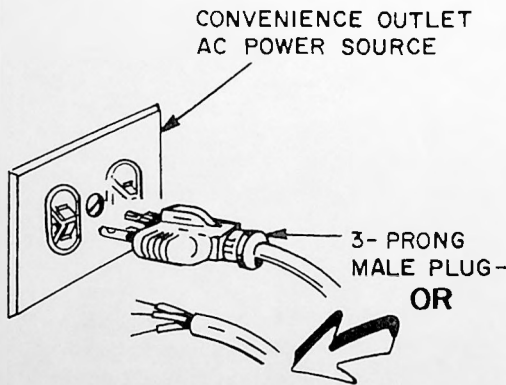

Figure 2-5. AC Power Cord Terminations

**CAUTION**

Connecting teleprinter to improper AC power source can cause serious damage to unit. BE SURE VOLTAGE IS CORRECT BEFORE PLUGGING INTO SOCKET.

All units are normally wired so that both sides of the AC power line are opened and closed by the Power ON/OFF Switch, and one side (Live Side) of the line is fused. If it is ever necessary that the Line Fuse be replaced, be certain that the replacement fuse is of the same value as the one originally installed in the machine.



c. DUAL-PRIMARY TRANSFORMER

As an option that must be specified at the time of ordering Series AF teleprinters can be equipped with a Dual-Primary Transformer, allowing the user to change the operating voltage of the machine. Normally, units which are equipped with this option are shipped from the factory wired for 230 VAC operation. Again, reference should be made to the Status Card attached to each teleprinter to ensure that this is, in fact, the case for that particular machine.

If for some reason the operating voltage of a unit equipped with the Dual-Primary Transformer must be changed, the installing technician must gain access to the power supply within the cabinet. To do this, follow the instructions outlined in paragraph 2-11 dealing with INTERNAL ACCESS.

To change the operating voltage, the plastic protective cover over the transformer terminals must be removed. This can be accomplished by loosening its two retaining screws and sliding the cover toward the front of the unit while lifting upward. Referring to Figure 2-6, remove the existing jumper wire(s) and solder new jumper wire(s) to the appropriate terminal lugs, as indicated in the Figure 2-6 schematic.

NOTE

When changing operating voltage, the fuse (housed in fuse holder on Rear Bracket Assembly) must also be changed to conform to the values shown in Figure 2-6. The alternate value fuse is provided in a retaining clip on the transformer.

Once the jumper wires have been soldered to the correct terminals, replace the protective cover and re-assemble the cabinet.

When you are certain the teleprinter meets the electrical specifications of the area in which it is to be used, the power cord may be connected to the appropriate receptacle.

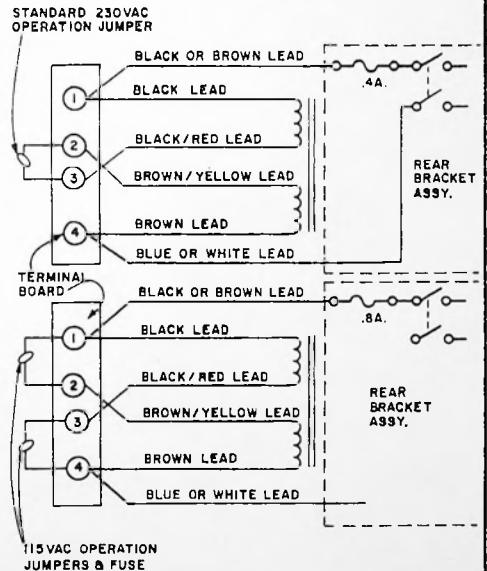

Figure 2-6. Dual-Primary Transformer Voltage Programming Schematic

SECTION 2  
INSTALLATION



2.6. SIGNAL INTERFACE

a. NEUTRAL/POLAR/AUDIO LINES

Series AE and AF teleprinters may come equipped with a variety of signal line terminations. In general, the Signal Line Cable is attached to the teleprinter, either as a "hard-wired" cable extending from the rear of the unit, or as a cable fitted with a connector which mates with a Signal Line Receptacle mounted on the teleprinter's Rear Bracket Assembly. (See Figure 2-7.) Additionally, this Signal Line Cable may be terminated at the opposite end in a number of different ways. Figure 2-7 illustrates the most common forms of termination for units designed to operate with DC current loops or audio input signals. Before making any signal line connections, check the Status Card attached to the machine for complete information on the type of signal your particular machine is designed to accept.

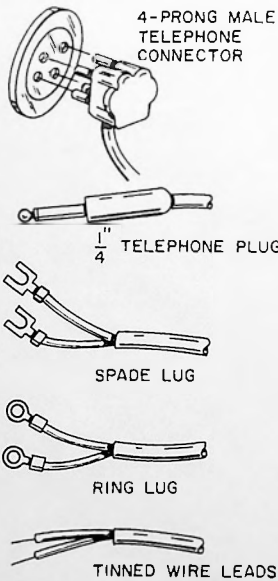
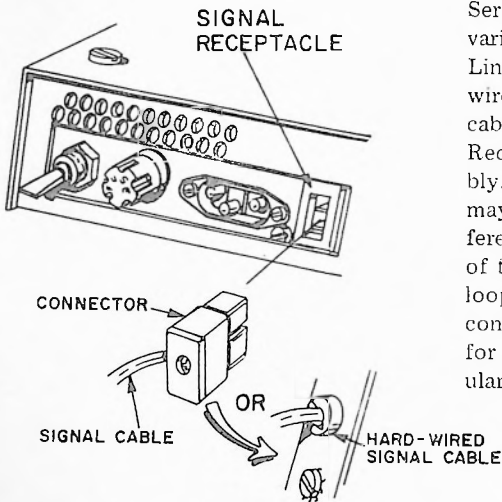

CAUTION

If a teleprinter equipped for audio signal use is connected to a DC source, serious damage to the modem will result. No damage will occur if the reverse connections are made; however, the teleprinter will be inoperative after AC power is applied, and the CIRCUIT ALARM LAMP will remain lit to signify an open circuit.

Figure 2-7. Signal Line Cable Terminations

The teleprinter is designed to normally operate from any DC signal line current, neutral or polar, between 10 and 60 milliamperes. However, if the unit is to be operated from peripheral equipment having a higher current rating than 60 milliamperes, current limiting resistor(s) of proper value must be placed in series with the DC input signal line. When specified at the time of ordering, the resistor(s) will be factory installed on the input printed circuit board. Provisions have been made on this board to accommodate a pair of 2-watt resistors in series with the loop for field modification.



NOTE

The jumpers presently installed on the input printed circuit board must be removed before installing the new resistor(s).

When the teleprinter is interfaced with an external audio modem, the current setting should be between 30 and 50 milliamperes in the MARK condition. Refer to the instruction manual for the external modem for specific adjustment procedures.

In some cases it will be recommended that a 620 ohm terminating resistor be installed in the telephone wall jack on audio lines. Figure 2-8 illustrates Part No. 1417 and the correct installation position for the 620 ohm ( $\pm 5\%$ ,  $\frac{1}{4}$  watt) resistor.

NOTE

When initially connecting the signal line, it may be necessary to reverse the polarity of the line before the teleprinter will receive properly.

TO REVERSE POLARITY:

To reverse the polarity of the signal line on units which utilize the connector/receptacle method of attachment to the teleprinter, simply remove the signal line connector and locate the polarizing key wedged into its housing. Pry this key out of the housing and re-install it on the other side of the connector. Re-insert the connector into the signal line receptacle.

On machines having a "hard-wired" signal line cable, it will be necessary to reverse the leads at the terminal connecting point in order to change polarity.

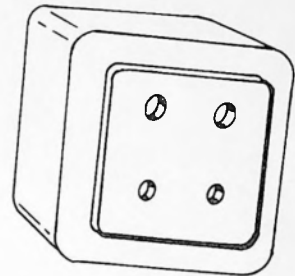

PART NO. 1417

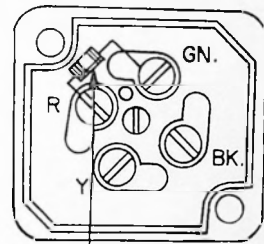

620 OHM ( $\pm 5\%$   $\frac{1}{4}$  W)  
CARBON RESISTOR

Figure 2-8. Wall Jack with Audio Line Terminating Resistor

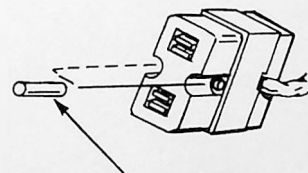

POLARIZING KEY

Figure 2-9. Signal Line Cable Connector

SECTION 2  
INSTALLATION





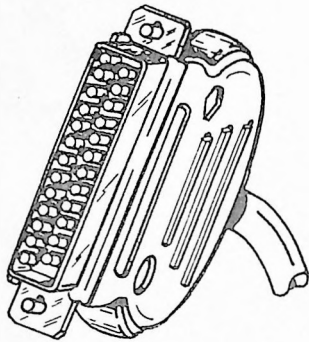

Figure 2-10. 25-Pin EIA Connector

b. RS-232-C (EIA) INTERFACE

On teleprinters using the commonly-referred-to EIA-type interface, the signal line cable will generally be "hard-wired" to the teleprinter and terminated with a 25-pin connector like that shown in Figure 2-10. Series AE and AF machines designed for use with this interface utilize the following connector pins and associated signals:

Pin No. 1	Protective Ground
" " 2	Transmitted Data (Always -14 VDC)
" " 3	Received Data
" " 7	Signal Ground
" " 20	Data Terminal Ready (+14 VDC)

Figure 2-11 is a wiring schematic for the EIA interface, showing wire colors and their connections within the teleprinter.

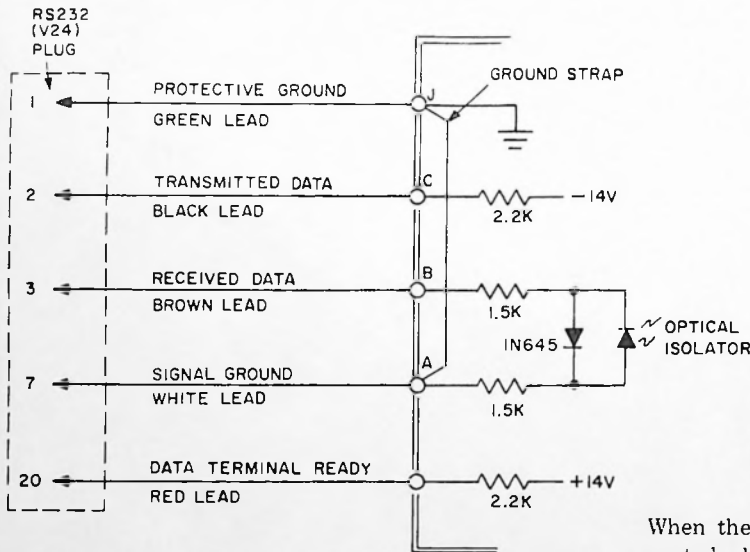

Figure 2-11. EIA Wiring Schematic

NOTE

When the signal line has been connected, be certain that the teleprinter's Speed Control Switch has been set to the proper position for the baud rate at which the unit will be receiving data. The Status Card on the unit will tell you the two baud rates at which the machine will operate.



2.7. OPERATING FREQUENCIES

The operating speed of the teleprinter may be changed by use of the Speed Control Switch which selects either of two crystals installed in the unit. This switch is positioned in the front right-hand corner of the printer mechanism base (See Figure 2-12), and is accessible by lifting the hinged lid in the teleprinter cover.

On teleprinters with a ribbon mechanism, access to the Speed Control Switch must be made by inserting the finger through the carriage drive belt loop and moving the switch handle to the left or right. (An opening in the ribbon mechanism allows access to the switch.)

**CAUTION**

Power to the unit must be turned OFF when changing from one speed to another.

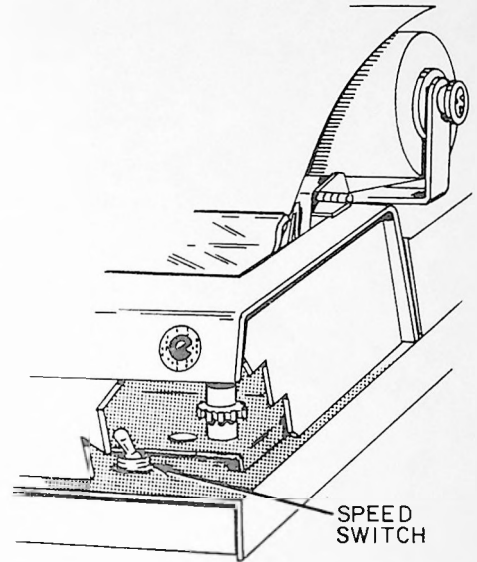

Figure 2-12. Speed Switch Location

SECTION 2  
INSTALLATION

Crystal frequencies bear direct correlation to applicable baud rates for the various unit codes used. Thus, if it is necessary to convert the teleprinter for use at a different baud rate the crystals on the Driver printed circuit board must be changed.

Consult the chart below for correct crystal frequency and part number for various operating speeds.

PART NO.	FREQ. KHz	BAUD RATE	CHARACTERS PER SECOND				
			5-LEVEL CODE		8-LEVEL CODE		6-LEVEL CODE
			7.42	7.5	10	11	8.5
2354 01	25.6	50	6.74	6.667	5.0	4.545	5.882
-02	38.4	75	10.108	10.0	7.5	6.818	8.824
-03	56.32	110	14.825	14.667	11.0	10.0	12.941
-04	57.6	112.5	15.162	15.0	11.25	10.227	13.235
-05	23.296	45.5	6.123	6.067	4.55	4.136	5.353
-06	84.48	165	22.237	22.0	16.5	15.0	19.412
-07	102.40	200	26.954	26.667	20.0	18.182	23.529
-08	51.2	100	13.477	13.333	10.0	9.091	11.765
-09	37.547	73.33	9.883	9.777	7.333	6.666	8.627
-10	28.8	56.25	7.581	7.5	5.625	5.114	6.618
-11	28.493	55.65	7.5	7.42	6.565	5.059	6.547
-12	37.99	74.2	10.0	9.893	7.42	6.745	8.729
-13	153.6	300	40.431	40.0	30.0	27.273	35.294
-14	26.9	52.539	7.081	7.005	5.254	4.776	6.181
-16	115.2	225	30.32	30.0	22.5	20.45	26.471
-17	76.8	150	20.216	20.0	15.0	13.363	17.647
-18	40.96	80	10.781	10.667	8.0	7.272	9.412
-19	34.15	66.7	8.99	8.893	6.67	6.063	7.847
-20	29.133	56.9	7.668	7.587	5.69	5.173	6.694
-21	43.52	85	11.456	11.333	8.5	7.727	10.0
-22	65.28	127.5	17.183	17.0	12.75	11.591	15.0



**TO CHANGE CRYSTALS:**

- (1) Remove the teleprinter cover, power supply cover and typing unit base, as outlined in Paragraph 2-11.
- (2) Locate crystals on the Driver printed circuit board (the uppermost of the two boards mounted in the base of the teleprinter).
- (3) Remove crystals from Driver Board and replace with crystals of proper frequencies for the baud rates at which the machine is to operate. See chart for crystal frequencies and applicable baud rates.
- (4) Re-assemble teleprinter cabinet as per Paragraph 2-11 of this Section.

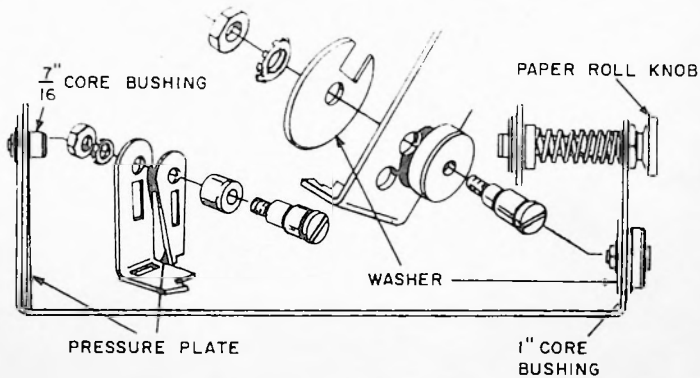

Figure 2-13a. Paper Roll Bracket for 8½" or 210 mm, 7/16" Core Roll with Pressure Plate

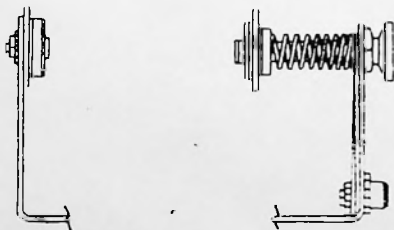

Figure 2-13b. Paper Roll Bracket for 8½" or 210 mm, 1" Core Roll, with Washer

**2-8. PAPER ROLL BRACKET**

If your machine is not equipped with a Sensor Unit for Low Paper, the Paper Roll Mounting Bracket will appear as one of the four configurations shown in Figure 2-13. All Series AE (6-inch machines) will have a Paper Roll Bracket like that shown in Figure 2-13a; that is, one which utilizes a pressure plate and bushing to accept 7/16-inch core rolls. Likewise, Series AF (8½-inch) Teleprinters not equipped with



March 1, 1975

ribbon mechanisms will usually possess a Paper Roll Bracket of similar configuration. (In some cases, however, non-ribbon Series AF units will have Paper Roll Brackets like the one shown in Figure 2-13d which uses a washer in place of the pressure plate.)

Model AFR (8½-inch, ribbon) machines will have Paper Roll Brackets like those shown in Figures 2-13b and 2-13c; that is, brackets utilizing a bushing to accept one-inch core paper rolls and either a washer or pressure plate. All Paper Roll Brackets on Series AF Teleprinters are designed to accept *either* 8½-inch wide rolls or 210 mm-wide rolls interchangeably *without any changes* to the Paper Roll Bracket.

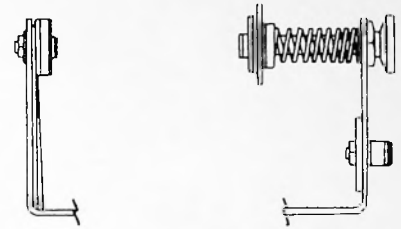

Figure 2-13c. Paper Roll Bracket for 8½" or 210 mm, 1" Core Roll with Pressure Plate

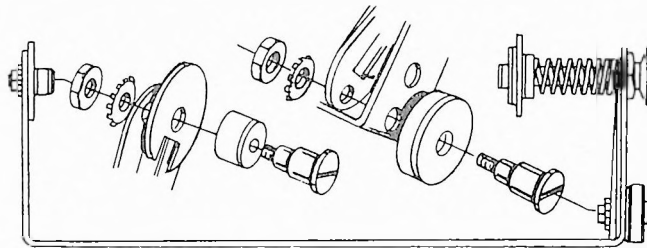

Figure 2-13d. Paper Roll Bracket for 8½" or 210 mm, 7/16" Core with Washer

In all cases, on Series AF machines, the Paper Roll Bracket Assembly contains all the components needed to convert the bracket to any of the other types. Note that in each case the unused components are stored on the right side of the bracket under the Paper Roll Knob. All assemblies, then, contain a 7/16-inch core bushing, one-inch core bushing, washer, and pressure plate.

#### TO CONVERT PAPER ROLL BRACKET:

- (1) Remove Paper Roll from the Paper Roll Bracket.
- (2) Loosen nut securing the currently-used bushing and pressure plate (or washer) with a 3/8-inch Nut Driver.
- (3) Again, using a 3/8-inch Nut Driver, loosen the nut securing the "stored" components to the bracket.
- (4) Remove both nuts and shoulder screws along with all of the components.



March 1, 1975

- (5) Select either the washer or pressure plate to be used in new configuration.
- (6) Select the correct sized bushing for use in the new arrangement, and insert the shoulder screw into the bushing.
- (7) Place the washer or pressure plate in the correct position on the bracket and insert the shoulder screw (with bushing) through the hole as shown in Figure 2-13. Secure the assembly with the original No. 10 lock-washer and nut, using a 3/8-inch Nut Driver.
- (8) Assemble the unused components as shown in Figure 2-13, making sure the pressure plate or washer is retained on the inside of the bracket, and the unused bushing is on the outside of the bracket. Insert shoulder screw.

#### NOTE

Two holes are provided for mounting unused components. If the pressure plate is to be stored, use the lower hole. If the washer is being stored, use the upper hole.

- (9) Secure the assembly of unused components with the original No. 10 lockwasher and nut using a 3/8-inch Nut Driver.

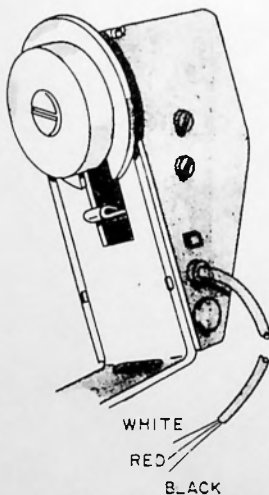

Figure 2-14. Sensor Unit for Low Paper Alarm  
(Rear View)

## 2-9. SENSOR UNIT FOR LOW PAPER ALARM

As an option, requested at the time of ordering, your machine may be equipped with a Sensor Unit for Low Paper Alarm. This Sensor Unit is installed on the left side of the Paper Roll Bracket Assembly as shown in Figure 2-14 (Rear View).

Depending upon its intended application, this Sensor Unit may be wired into the teleprinter (as in most Selective Calling applications), or its connecting wires may be shipped unconnected for hook-up to some external signalling device by the installer.



The Sensor Unit contains either a "Normally-open" or "Normally-closed" pair of switch contacts which are activated when the teleprinter has reached the end of a roll of paper. Wire colour code is as follows:

- White Lead - Common Switch Contact
- Red Lead - Normally-open Switch Contact
- Black Lead - Normally-closed Switch Contact

Installer should connect the proper pair of leads from the Sensor Unit to the particular external alarm device which is to be used.

## 2-10. LOGIC BOARD PROGRAMMING OPTIONS

Under normal circumstances the teleprinter is ready to be put into operation just as it arrives from the factory. If specified at the time of ordering, the Logic Board in your machine was programmed to provide the options you requested. In some instances, however, it may be necessary for the installing technician to change the printing requirements of the unit, and the following charts provide the information necessary to do this.

The various printing options available on your particular machine will depend on which Logic Board Series is installed in that unit. The Status Card attached to the teleprinter will identify the series of Logic Board used in your machine. For

instance, if the Status Card identifies the Logic Board as being a 7052-03, the unit then has a 7050 Series Logic Board, and the appropriate chart should be consulted for programming information.

The printing options are controlled by means of an 8-position dual-inline switch array located on the Logic Board in the front left-hand corner of the Electronics Base. In order to gain access to this switch array, it will be necessary to follow the procedure outlined in Paragraph 2-11b. In most cases a label is affixed to the Logic Board showing ON and OFF positions of the switches. If a label is not present, the ON positions is *toward the numbers*.

### 7050 SERIES

Switch in ON position activates Option

1. Bell on "J"
2. Bell on "S"
3. No Print on "H"
4. No Print on "G"
5. No Print on "F"
6. Carriage Return on Line Feed
7. Line Feed on Carriage Return
8. Unshift on Space

### 7060 SERIES

Switch in ON position activates Option

1. Carriage Return on Line Feed
2. Monitor
3. Line Feed on Carriage Return
4. Bell on "S"
5. Bell on "J"
6. Unshift on Space



**7981 SERIES**

- Switches 1, 2, 3, 4      Have no Effect
- Switch      5      OFF - 3-, 5-Character Selective Calling  
ON - 2-Character 83B3
- Switch      6      OFF - Normal  
ON - **BOLD FACE HEADING** (Note: Switch 6 creates Bold Face headings only if Switch 5 is OFF.)
- Switch      7      OFF - Selective Calling Enabled  
ON - Selective Calling Disabled
- Switch      8      OFF - 72-Character Line  
ON - 40-Character Line
- Line Feed Switch      Left - 1½-Line Feed  
Center - Single-Line Feed  
Right - Double Line Feed
- Jumper      JU-3      Deleted - Normal  
Inserted - Five-Bell Alarm Option  
† *CAUTION* † Jumper must be deleted on AA - AF Series machines.
- Jumper      JU-4      Deleted - Normal

**7086/7986 SERIES**

- Switch      1      OFF - Normal  
ON      Test Message Prints when power is turned ON.
- Switch      2      OFF - Normal  
ON      - Last Character Visibility (LCV) ON

**EIGHT-LEVEL**

- Switch      3      OFF & Switch 4 OFF - 64-Character Mode
- "      OFF "      "      "      ON - 96-Character Mode
- "      ON "      "      "      OFF - 128-Character Mode
- "      ON "      "      "      ON - 128-Character Special
- Switch      5      OFF & Switch 6 OFF - Normal
- "      OFF "      "      "      ON - New Line on Car. Ret.
- "      ON "      "      "      OFF - New Line on Line Feed
- "      ON "      "      "      ON - New Line on Line Feed

**FIVE-LEVEL**

- Sw 3 OFF — Normal
- Sw 3 ON — Full Monitor
- Sw 4 OFF — Bell on 'J' (CCITT No. 2)
- Sw 4 ON — Bell on 'S' (U.S.)
- Sw 5 OFF — Normal
- Sw 5 ON — New Line on Line Feed
- Sw 6 OFF — Normal
- Sw 6 ON — New Line on Carriage Return



Switch	7	OFF	&	Switch	8	OFF	-	69-Character Line
	"	OFF	"	"	"	ON	-	72-Character Line
	"	ON	"	"	"	OFF	-	74-Character Line
	"	ON	"	"	"	ON	-	80-Character Line

Line Feed Switch	Left	-	1½-Line Feed
	Center	-	Single-Line Feed
	Right	-	Double-Line Feed

Jumper	JU-3	Deleted	-	Normal
		Inserted	-	Five-Bell Alarm Option
		† CAUTION † Jumper must be deleted on AA - AF Series Machines.		

Jumper	JU-4	Deleted	-	Normal
--------	------	---------	---	--------

†† WARNING ††

VOLTAGES DANGEROUS TO LIFE ARE PRESENT IN THIS EQUIPMENT! Disconnect unit from AC Power Source *before* attempting access to teleprinter's internal components.

2-11. INTERNAL ACCESS

a. To Remove Teleprinter Cover:

- (1) Cut the paper and remove excess paper which may be threaded around the platen.
- (2) Pull off the platen knob from the platen shaft.
- (3) Loosen the screw on the rear of the cover (shown in Figure 2-15) until it clears the retaining bracket slot by approximately ¼ inch. This single screw holds the teleprinter cover to the printer base.

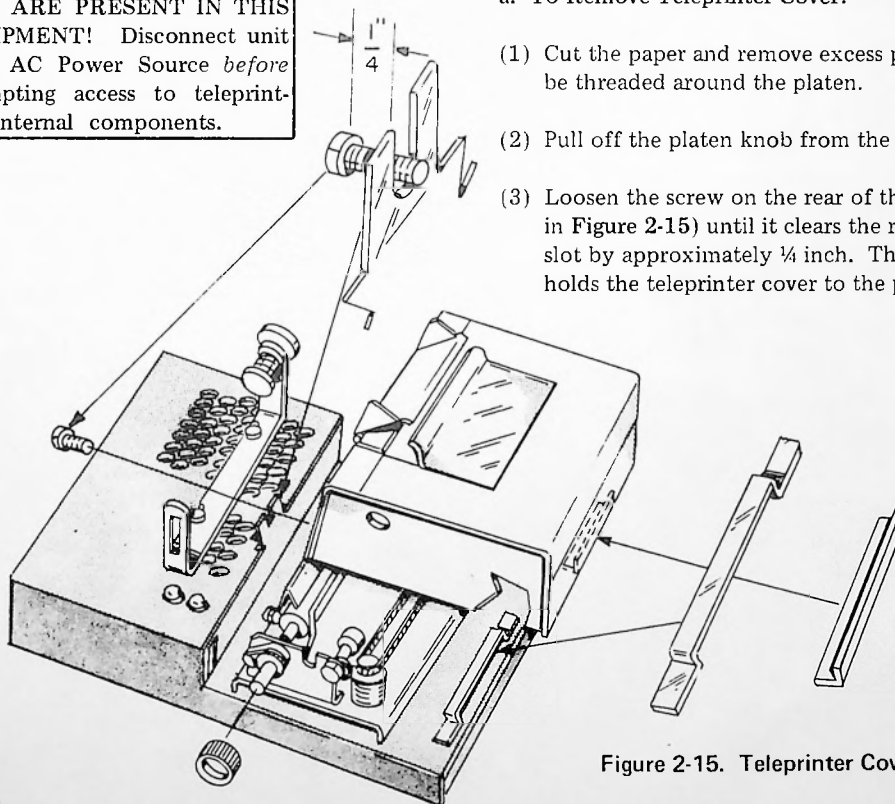

Figure 2-15. Teleprinter Cover Removal





March 1, 1975

**CAUTION**

To avoid damage to the platen shaft when removing the cover, carefully move the Typing Unit Cover to the left so as to clear the platen shaft.

- (4) Refer to Figure 2-15. Slide the cover forward (toward the front of the machine) slightly to permit the cover mounting lip to disengage from its retainer at the front of the printer base.
- (5) Slowly and carefully lift upward and to the left, removing the teleprinter's cover.
- (6) To Replace Cover: Reverse steps (1) through (5).

† † †

## b. To Gain Access to Printed Circuit Board Assemblies:

- (1) Remove the Typing Unit Cover as directed in Sub-paragraph "a" above.
- (2) Note the orientation of—and tag—the four P.C. Connector Boards to the right of the typing unit. Consult Figure 2-16.
- (3) Disconnect the four P.C. Connector Boards at the right side of the Typing Unit by simply pulling upward on each of them. [NOTE: Machines having ribbon mechanisms have an additional connector attached to the top of two of the P.C. Connector Boards. This connector can be removed together with the other boards, and must be re-installed as shown in Figure 2-16 when re-assembling unit.]

Consult Figure 2-16 as you Proceed.

- (4) Remove the five Power Supply Cover mounting screws located on the top of the unit in the Paper Roll Bracket area.
- (5) Grasping the sides the the Power Supply Cover, lift upward to remove the cover. This exposes the Power Supply printed circuit boards.
- (6) Remove the four printer base mounting screws, securing the Printer Base to the Electronics Base.

**CAUTION**

These Connector Boards *must* be re-installed in the proper direction when re-assembling the unit, or serious damage to the teleprinter may result.



- (7) Slowly and carefully lift upward Printer Base by grasping the sides of the base. DO NOT grasp the typing unit assembly to remove base. Once removed, this exposes the electronics base, containing Logic, Driver and Input printed circuit board assemblies.
- (8) To Re-assemble Cabinet, reverse steps (1) through (7).

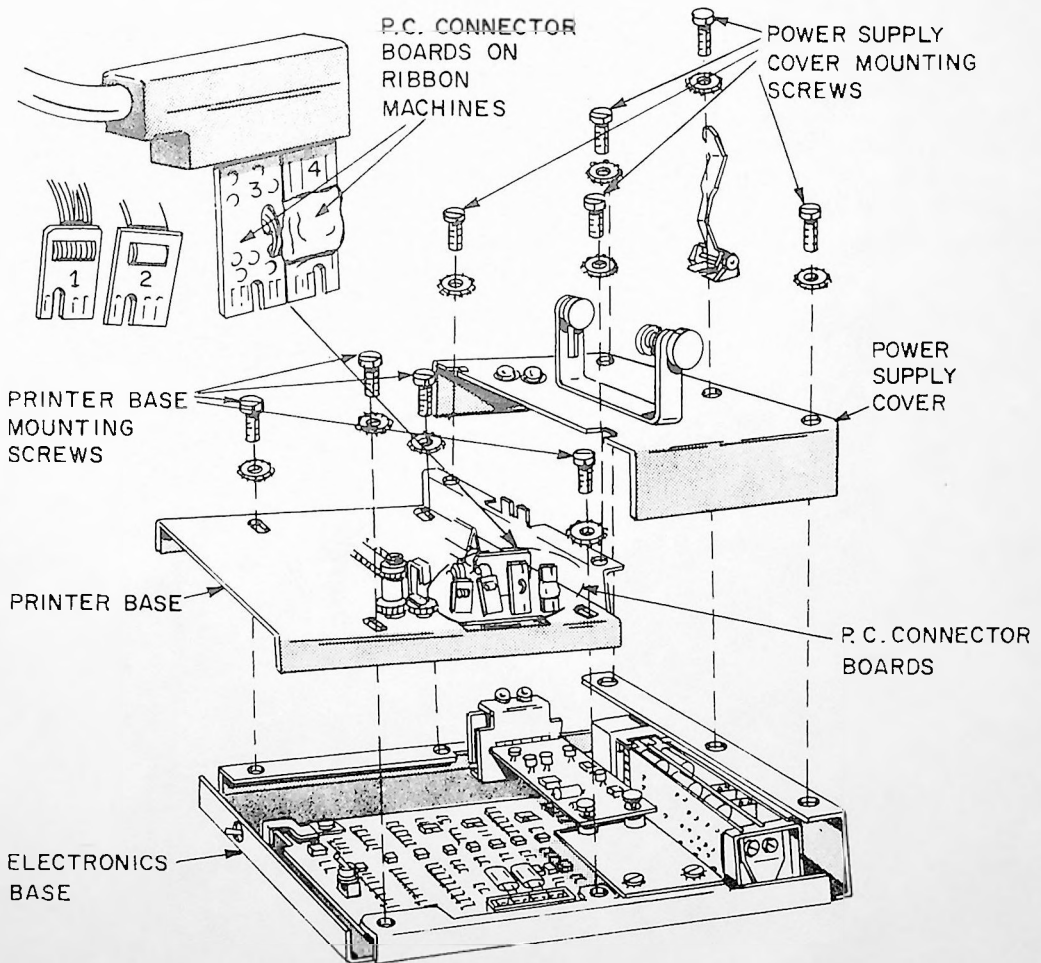

Figure 2-16. Removal of Power Supply Cover and Printer Base



2-12. PAPERWINDER INSTALLATION

The optional Paperwinder Assembly comes packed in a separate container and must be installed on the teleprinter by the servicing technician.

TO INSTALL PAPERWINDER ASSEMBLY:

- (1) Place the teleprinter Power ON/OFF switch in the OFF position.
- (2) Refer to Paragraph 2-8 of this Section, and configure the Paper Roll Bracket Assembly as shown in either Figure 2-13a or 2-13c, depending on the type of paper to be used on the unit. (NOTE: These Paper Roll Bracket Assemblies use the Pressure Plate.)
- (3) Remove and discard the three machine screws along the top rear edge of the Power Supply Cover. See Figure 2-16.
- (4) Position the Paperwinder Mounting Bracket over the Power Supply Cover so all three mounting holes are properly aligned.
- (5) Using the two 8-32 x 15/16 machine screws, No. 8 lockwashers, and No. 8 flatwashers supplied with the Paperwinder Assembly, temporarily secure the front of the Paperwinder mounting bracket to the Power Supply Cover. See Figure 2-17.

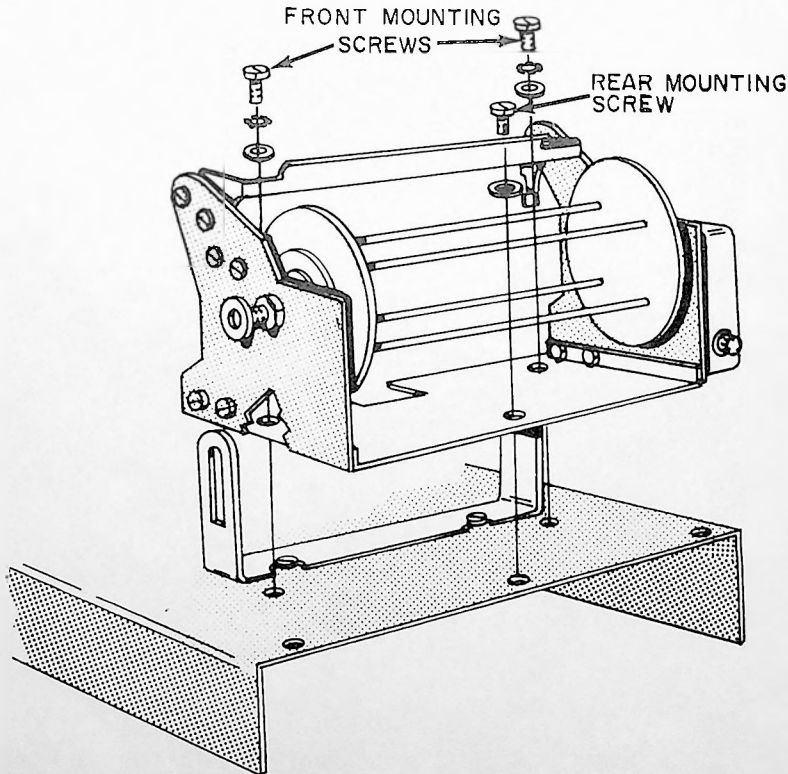

Figure 2-17. Paperwinder Installation Diagram



- (6) Using the 6-32 x 3/8 pan-head machine screw and large flat washer supplied with the Paperwinder Assembly, secure the rear center position of the Paperwinder mounting bracket to the Power Supply Cover. See Figure 2-17.
- (7) Assemble the Paperwinder Take-up Reel by inserting the tapered ends of each pair of rods into their respective holes in the opposite reel disc.
- (8) Pull outward on the spring-loaded knob and hold it firmly while seating the motor drive shaft into the center of the left hub of the Take-up Reel and aligning the right hub of the reel with the spindle in the spring-loaded knob. Release the knob.
- (9) Follow procedure outlined in Paragraph 3-2b for loading paper roll into machine.
- (10) If required, slide the Paper Roll Bracket either to the left or right (loosen its two mounting screws using an offset common-head screwdriver) until the left edge of the paper roll is 1/4 or 7/32 of an inch from the left edge of the window opening.
- (11) Adjust the Paperwinder Assembly until approximately 1/32-inch visual clearance exists between the inside face of the right-hand reel disc and the right edge of the paper roll.
- (12) Tighten the three mounting screws to permanently secure the Paperwinder Assembly to the Teleprinter Power Supply Cover.
- (13) Again consult Paragraph 3-2b (steps 8-11) of Section 3 for procedure for threading paper into Paperwinder.
- (14) Plug the Paperwinder Power Cord into an AC power outlet of the proper voltage (Check tag attached to power cord) and frequency. Turn both Paperwinder and Teleprinter Power Switches to the ON position.

**2-13. SYSTEMS INTEGRATION**

The following page contains a Block Diagram pertaining to Series AE and AF Teleprinters.

The Diagram depicts the interconnection of the various electronic systems used in the machine. In those cases where shading appears around the block, this denotes an optional electronic circuit.

SECTION 2  
INSTALLATION



March 1, 1975

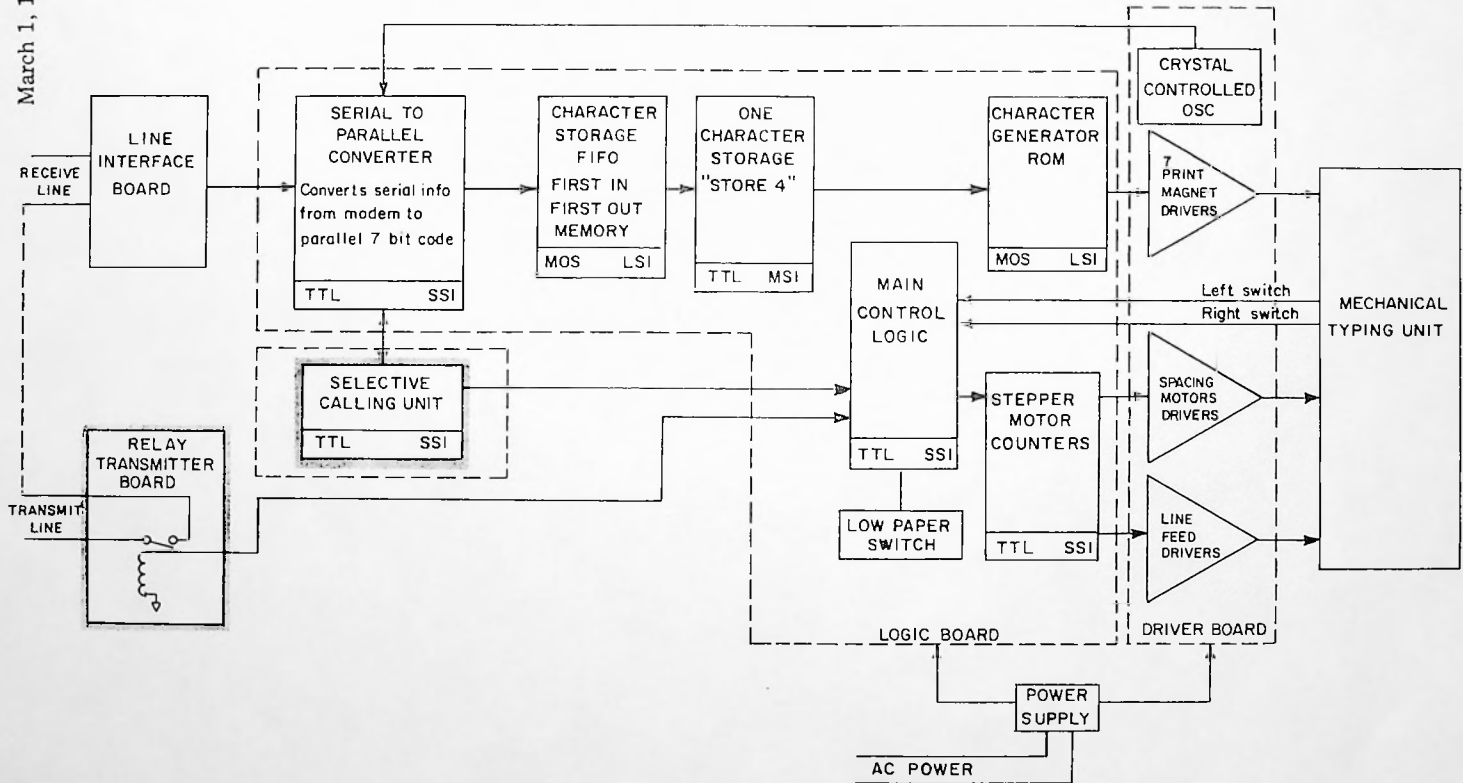

BLOCK DIAGRAM  
AA-THRU-AF  
SERIES LOGIC



## SECTION 3 Operation

### 3-1. GENERAL

This section deals with procedures which are basically the operator's responsibility. Paper and ribbon installation are frequently-performed activities for the operator, and if they are done consistently in the correct manner, the operational reliability of the teleprinter can be significantly prolonged. It is, then, of great importance that operators fully understand the proper methods for performing the procedures outlined in this section.

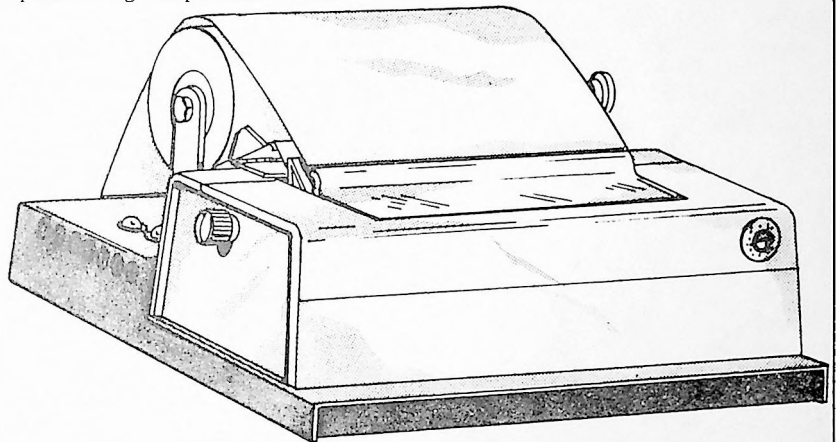

Once the teleprinter has been correctly installed, as described in Section 2, it is basically ready for operation. It will, however, probably require the installation of paper and/or a ribbon. If any abnormal conditions are observed while following the instructions in this section, it is recommended that you notify an authorized service technician before proceeding further.

### 3-2. PAPER INSTALLATION

#### a. TYPES OF PAPER

Series AF Teleprinters which are equipped with ribbon mechanisms use any standard teleprinter paper  $8\frac{1}{2}$  inches (215 mm) wide, with a roll diameter of 5 inches (127mm) or less and an inner core (spindle) diameter of 1 inch (25.4 mm). Current Paper Roll Bracket assemblies are designed to automatically accept the narrower 210 mm paper rolls as well.



Series AF Teleprinters with ribbon mechanisms can also use pressure-sensitive paper if the Paper Roll Bracket is converted—as described in Paragraph 2-8—to accommodate the smaller 7/16-inch spindle diameter. Up to three plies of either type of paper can be used.

Units which are not equipped with ribbon mechanisms use pressure-sensitive, ink-encapsulated paper. This paper is available in 8½-inch (215 mm), 210 mm, or 6-inch widths, with a 5-inch (127 mm) roll diameter and 7/16-inch core diameter. Again, up to three-ply paper may be used.

**b. PAPER LOADING**

The correct loading of paper into the machine is the single most important function which must be performed by the operator. Use Figure 3-1 to identify parts of the teleprinter which are referred to in the following procedure. Figure 3-2 illustrates a side view of the correctly-threaded paper path through the machine.

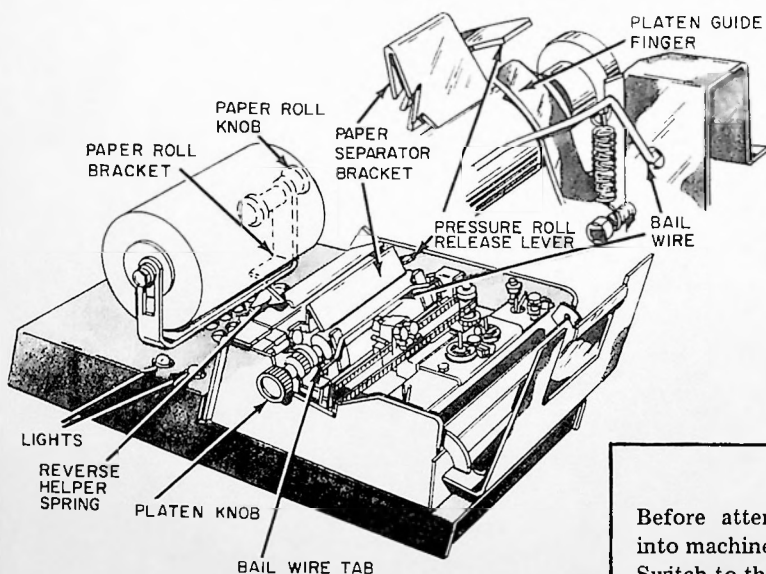

Figure 3-1. Typing Unit Component Identification

**CAUTION**

Before attempting to load paper into machine, turn the Power ON/OFF Switch to the OFF position. (If the machine is equipped with a Paperwinder, its Power Switch must also be placed in the OFF position.)



March 1, 1975

## To Load Paper:

- (1) Remove the gum label or adhesive securing the starting edge of the paper roll.
- (2) Display a sufficient amount of paper spoiled by the adhesive and tear or cut it off with a pair of scissors. (A square cut makes initial insertion of paper easier.)
- (3) Pull outward on the paper roll knob and insert the paper roll into the paper roll bracket assembly so that the paper feeds from the underside of the roll. (See Figure 3-2.) Release the paper roll knob, allowing the bushing on the knob to settle into the paper roll core.
- (4) Raise the hinged lid of the front cover and pull forward on the bail wire tab, located on the left side of the bail wire (See Figure 3-1.), to move the bail wire away from the platen.
- (5) Pass the starting edge of the paper roll over the hinged Reverse Helper Spring assembly and insert it into the opening between the Separator Bracket and the upper hex tie rod. (*Insert paper as far as it will go without wrinkling.*)
- (6) Rotate the platen knob toward the rear of the unit to advance the paper around the platen and back over the Separator Bracket. If the paper is slightly off-center, depress the Pressure Roll Release Lever (See Figure 3-1.) and center the paper manually.
- (7) Return the bail wire to its original position and close the hinged lid.

If a Paperwinder assembly is *not* being used, the paper threading procedure is complete. The Power ON/OFF Switch may be returned to the ON position.

† † †

If a Paperwinder assembly is being used, leave the Power Switches in the OFF position and complete the threading procedure described below. Refer to Figure 3-3.

- (8) Visually check to see that no interference exists between the inside faces of the Paperwinder Reel and the edge of the paper roll.

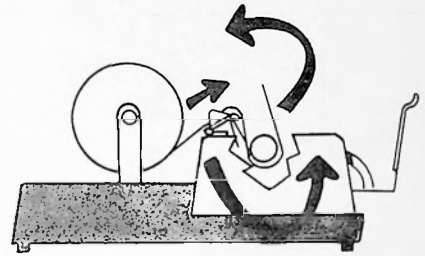

Figure 3-2. Paper Threading Diagram

## NOTE

For your convenience, the paper is often marked with RED WARNING STRIPES to indicate the end of the roll. When they appear, paper should be changed at next convenient interval.





- (9) Turn the Platen Knob *counterclockwise* to advance the paper approximately two feet.

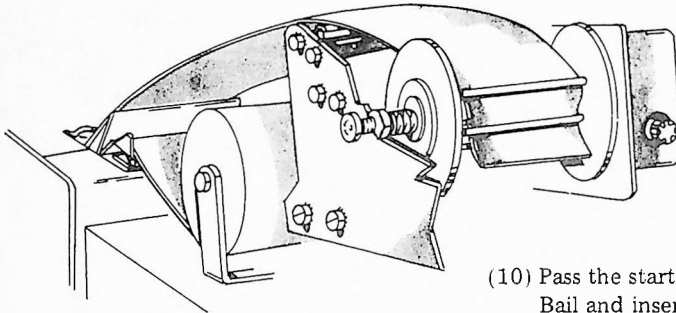

Figure 3-3. Paperwinder Threading Diagram

- (10) Pass the starting edge of the paper over the Paperwinder Bail and insert it between any two rods on the Take-up Reel, as shown in Figure 3-3.
- (11) Turn the Paperwinder Power ON/OFF Switch to the ON position. (The Paperwinder Reel will begin to rotate, taking up any slack in the paper.)

**c. REMOVAL OF PAPER FROM PAPERWINDER**

- (1) Turn the Paperwinder and Teleprinter Power Switches to their OFF positions.
- (2) Support the underside of the paper wrapped around the Paperwinder Take-up Reel with one hand, and with the other hand pull outward on the Reel Release Knob.
- (3) While still holding the Reel Release Knob, move the Take-up Reel toward the Reel Release Knob to free the left reel hub from the motor drive shaft.
- (4) When the left reel hub has cleared the motor drive shaft, remove the Paperwinder Take-up Reel from the Paperwinder Mounting Bracket and release the knob.
- (5) Vertically position the Paperwinder Take-up Reel on a flat surface and pull upward on the top reel disc, separating the two parts of the Take-up Reel as shown in Figure 3-4. The paper can now be removed.
- (6) Re-assemble the Paperwinder Take-up Reel by inserting the tapered ends of each pair of rods into their respective holes on the opposite reel disc. See Figure 3-4.

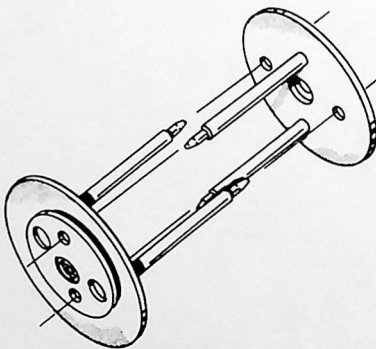

Figure 3-4. Paperwinder Take-up Reel



March 1, 1975

### 3-3. RIBBON INSTALLATION

Series AF Teleprinters which are equipped with Ribbon Mechanisms are designed to use a standard NYLON TELE-PRINTER RIBBON with spools. It is *imperative* that a NYLON ribbon be used to avoid the build-up of cotton fibre in the carriage assembly. These ribbons may be ordered from Extel Corporation under Part No. 5103. The ribbon should be discarded when the printed characters become illegible or too light to read. Additional ribbon life may be obtained by simply switching ribbon spool positions, thus inverting the ribbon.

Raise the hinged lid of the teleprinter cover and note the diagram affixed to the inside of the cover. This diagram is reproduced here as Figure 3-5 and reference should be made to it while installing the ribbon to ensure that proper threading path is followed.

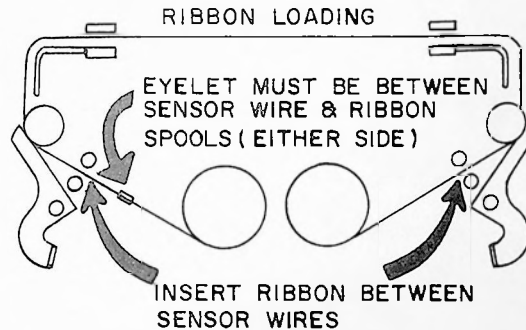

Figure 3-5. Ribbon Threading Diagram

#### To Install Ribbon:

- (1) Gently pull forward on the Bail Wire Tab (Shown in Figure 3-1.) to move the bail wire away from the platen.
- (2) Carefully clear the ribbon from the left- and right-hand sensing wires. Depress one of the break arms inwardly (toward the rear of the machine) and lift ribbon free from its guide spool. Repeat this procedure for the other brake arm. Unthread the ribbon from remaining guides adjacent to the platen. See Figure 3-5.
- (3) If your replacement ribbon has a new take-up spool preconnected to it, proceed to Step 4.

If the replacement spools are *not* ribbon preconnected, you will have to engage the hook at the end of the ribbon over the protruding arrow in the hub of the empty spool. If no

#### CAUTION

Place the teleprinter's Power Switch in the OFF position before attempting Ribbon Installation. Damage to the carriage assembly and ribbon may result if unit is printing while ribbon is being installed.

#### CAUTION

Extreme caution should be observed when removing the ribbon from between the carriage and platen. Do not attempt to pull back on carriage assembly, as serious damage may result.



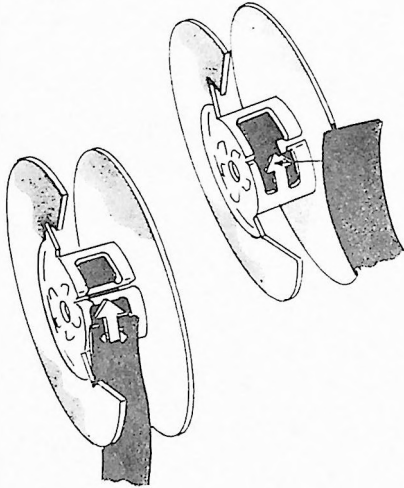

Figure 3-6. Attachment of Ribbon to Spool

hook is supplied, pierce the end of the ribbon over the point of the arrow. (See Figure 3-6.) Wind the ribbon onto the spool, rotating the spool in the direction indicated by the arrow. Continue winding ribbon onto the spool until the reversing eyelet has been wrapped around the spool.

- (4) Ensuring that the reversing eyelet is wrapped onto the take-up spool, place that spool on one of the spindles, being certain that it is engaged on the guide pin under the spool.
- (5) Unwind approximately 18 inches of ribbon from the full spool and then place that spool on the other spindle, engaging it on its guide pin.

**NOTE**

Be sure that the orientation of the spools and ribbon is as shown in Figure 3-5.

**CAUTION**

Extreme caution should be observed when placing the ribbon between carriage and platen. Do not attempt to pull back on carriage assembly or serious damage may result.

- (6) Starting from the full-ribbon spool, thread the ribbon through the sensing wire. Then, depress and hold the brake arm inward (toward the rear of the machine) while guiding the ribbon around the guide spool. Release the brake arm.
- (7) Guide the ribbon around the platen guide and then adjacent to the platen. When reaching the carriage, *CAREFULLY* guide the ribbon between the carriage and the platen.
- (8) Continue threading the ribbon through the remaining guides on the other side, i.e. around the platen guide and guide spool, through the sensing wire.
- (9) Rotate the take-up spool until the slack in the ribbon is removed, and again check to be certain the reversing eyelet is between the sensing wire and take-up spool. (If the eyelet is not in this position, damage could be caused to the ribbon mechanism, and the ribbon will not reverse automatically.)
- (10) Return the bail wire to its original position, close the hinged lid, and place the Power ON/OFF Switch in the ON position.



### 3-4. MESSAGE REMOVAL

#### a. SINGLE-COPY PAPER

To remove a received message on single-copy paper from the teleprinter (assuming it is not equipped with a Paperwinder), turn the platen knob to advance the paper to a point which allows adequate clearance between the last printed line and the top surface of the viewing window. Pull the paper **FORWARD AND TO THE RIGHT OR LEFT** against the edge of the viewing window to sever the printed message from the remaining paper.



Figure 3-7. Multi-Copy Tear-off Diagram

#### b. MULTI-COPY PAPER

When removing multiple copies from the machine, perform the following steps to eliminate uneven, ragged or mutilated message material:

- (1) Place thumb of left hand on printer cover while holding the papers *feeding* the teleprinter with fingers of the same hand. See Figure 3-7. (This will keep paper from feeding through the machine as tension is created on it during the tearing-off process.)
- (2) While pressure is being applied with the left hand, grasp paper at left corner with right hand and **PULL SMARTLY FORWARD AND TO THE RIGHT** against the cutting edge of the viewing window, as illustrated in Figure 3-7. The resulting separation will be straight and parallel to the lines of copy.



3-5. CONTROL SWITCHES

a. Line Feed Switch

Figure 3-8 shows the location of the Line Feed Switch at the lower left-hand side of the front of the unit. This is usually a two-position switch, allowing the choice of either single- or double-line feed, or single- or 1½-line feed, operation. But, with certain Logic Board installations the switch may be of the three-position type, allowing single-line feed when placed to the *left*, 1½-line feeds when positioned in the *center*, and double-line feeds when placed to the extreme *right*. From time to time the operator may wish to use this switch to alter the spacing between lines of copy.

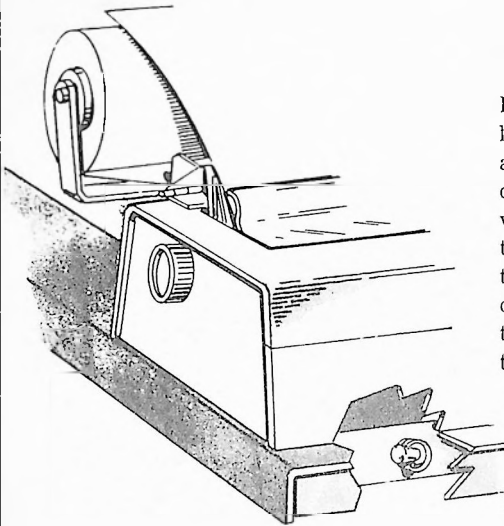

Figure 3-8. Line Feed Switch Location

b. Speed Switch

The teleprinter is equipped to operate at either of two speeds (baud rates), determined by crystals installed within the unit. Figure 3-9 shows the location of the switch at the front right-hand corner of the printing mechanism base. Access to the switch is obtained by lifting the hinged lid in the teleprinter cover.

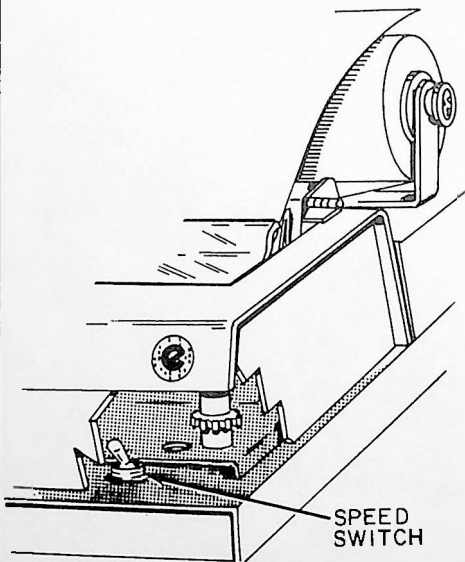

Figure 3-9. Speed Switch Location

CAUTION

Power to the unit must be OFF when changing from one operating speed to another.

In order to reach the switch on units employing a Ribbon Mechanism, it is necessary to insert the finger through the carriage drive belt, locating the switch in the opening provided in the Ribbon Mechanism frame.

On certain occasions the transmitting facility may inform the user that they are changing the baud rate at which they are transmitting data. This will necessitate the operator moving the Speed Switch to its alternate position.



### c. Full Monitor Switch

Figure 3-10 shows the location of this switch on the left-hand side of the machine, adjacent to the Paper Roll Bracket. When this switch is ON the teleprinter will print out the symbols for all functions, while performing all functions except "carriage return" and "line feed". While in the Full Monitor mode, the unit will print the unique symbols for "carriage return" and "line feed", but will not execute these mechanical operations at the time they are called for in the text. Rather, the teleprinter will completely fill each line with the maximum number of characters permitted and then automatically perform the "carriage return" and "line feed" operations.

The user will find this mode of operation useful when it is desirable to conserve paper usage and produce compact print-out of copy.

### d. Rail Monitor Switch

Machines equipped with this switch allow the user to monitor all Rail Shift symbols. In the ON position the switch permits the machine to print the unique symbols for "upper" and "lower" rail. Location of this switch is shown in Figure 3-10.

### e. Last Character Visibility (LCV) Switch

When the LCV Switch, shown in Figure 3-10, is in the ON position, a special interval line feed causes the paper to be advanced upward whenever a pause of more than one second occurs in the movement of the carriage across the platen. This moving of the paper upward aids considerably in viewing the last characters printed. When incoming traffic resumes, the platen then retracts the paper to its original position and printing continues where it had previously stopped.

## 3-6. OPERATOR-LEVEL MAINTENANCE

In general, Series AE and AF Teleprinters will provide trouble-free performance for long periods of time without

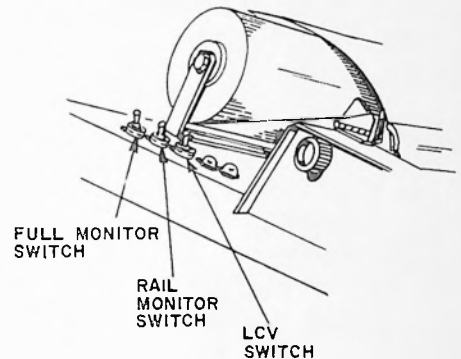

Figure 3-10. Monitor Switch Locations



March 1, 1975

extensive maintenance. There are, however, some simple maintenance procedures that will aid in extending the trouble-free life of the unit.

- (1) The teleprinter should receive **Periodic Preventive Maintenance** at *regular* intervals by a qualified service technician.
- (2) Remove all torn bits of paper from inside the cover. Excessive lint from the paper may be removed with a soft-bristle brush, using *slow, light brush strokes* so as not to scatter the lint to other parts of the machine.
- (3) Exterior metal surfaces may be cleaned using a mild cleaning detergent (such as Fantastik) which should be wiped off immediately using paper toweling or a lint-free cloth.
- (4) A mild detergent may also be used to clean the viewing window, but a protective cover should be placed over the internal mechanism to avoid spraying the cleaning agent onto it.

*CAUTION*

Only qualified service personnel should attempt cleaning of the carriage assembly.



## SECTION 4 Options

March 1, 1975

### 4-1. EMERGENCY BROADCAST SYSTEM (EBS) RELAY OPTION

If the EBS Relay Option was requested at the time of ordering, the unit has been equipped with a special transformer assembly which includes a socket for accepting an EBS relay. This relay, and a barrier strip for mounting on the outside of the teleprinter cabinet, are shipped separately with the machine.

The EBS Relay Option provides the user with a normally-open pair of contacts which function merely as a line closure, suitable for wiring in series (similar to a single-pole/single-throw switch) with some external signaling device, such as a bell, horn or light. The relay contacts are closed in response to an incoming "Bell-on-S" or "Bell-on-J" character.

#### NOTE

The label adjacent to the dual in-line switches on the Logic Board describes which switch to have in the ON position for "Bell on S" or "Bell on J".

#### CAUTION

Disconnect teleprinter from AC Power Source before attempting to install EBS Relay.

#### TO INSTALL EBS RELAY:

- (1) To gain access to the relay socket, follow instructions in Paragraph 2-11b, describing access to Printed Circuit Board Assemblies.
- (2) Locate the relay socket adjacent to the Power Transformer within the teleprinter electronics base and insert relay module.
- (3) Pins 1 and 5 of the relay socket have been wired in parallel with the bell coil, while the separate pair of wires, available to the installer, are wired to Pins 3 and 8—the normally-open contacts of the relay.
- (4) Mount the two-lead barrier strip on the exterior rear panel of the electronics base.
- (5) Consult Figure 4-1 below as you connect the two wires from Pins 3 and 8 of the relay socket to the barrier strip.
- (6) Re-assemble teleprinter cabinet as per instructions in Paragraph 2-11b in SECTION 2 of this manual.

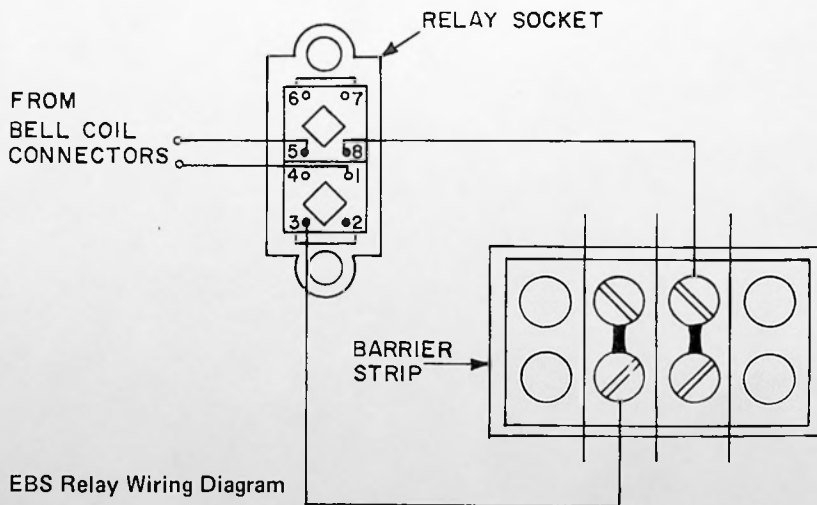

Figure 4-1. EBS Relay Wiring Diagram





## 4-2. 7305 SELECTIVE CALLING PROGRAMMING

The selective calling board provides the following programmable features: (1) print control, (2) call directing codes, (3) end of selection coding, (4) end of message coding, (5) answerback programming, (6) acknowledgement delay, and (7) acknowledge timing. Provisions are also available on the selective calling board for discrete call directing codes to activate a remote receiver or auxiliary transmitter. However, special factory modifications are necessary to achieve these programmable features.

Wire jumpers are strapped to selective calling terminals or pads, shown in Figure 4-2, and are used to implement the features described in the following paragraphs.

### a. Print Control

The print control strapping permits the unit to print between the reception of the EOM/alert code and End of Selection (EOS) code. The three variations of strapping are outlined below with reference to Figure 4-2.

If no strapping is used for pads 64-65-66, the teleprinter, upon reception of any programmed CDC, becomes enabled and prints its own "V" or "M" answerback code, all other CDC codes, acknowledgements (ACKs), and the EOS code.

If pads 64-65 are strapped, the unit will print only after receiving its own CDC code and the EOS code. It will not print its own ACK or the EOS code.

If pads 64-65-66 are strapped, the teleprinter will print all CDC codes, all ACKs on the circuit and the EOS code.

### b. Call Directing Codes (CDC's)

Call directing codes (CDC's) are assigned to a receiving teleprinter or group of receiving teleprinters to enable their selection or the activation of a remote receiver or transmitter. A given unit may be assigned five different CDC codes. These codes may be used for the following purposes: (1) STATION SELECTION-- for the teleprinter only, (2) GROUP SELECTION-- for the selection of several teleprinters on a circuit, (3) REMOTE OR AUXILIARY RECEIVER SELECTION-- for activating an auxiliary receiving device, such as a printer or tape punch, and (4) AUXILIARY TRANSMITTER POLLING-- for activating an auxiliary transmitter, such as a tape reader. The strapping for these codes is described below. It should be noted that only those codes to be used need be assign-

ed and strapped. The end of selection (EOS) code strapping is described separately.

Call directing codes for a single teleprinter can be one to six characters in length. The length for group call directing codes is a one or two character sequence. End of message (EOM) takes a four character code sequence. A description for one, two and six character strapping is given below with reference to Figure 4-2.

#### (1) Single Character

If a single character selection is desired, strap the first control input terminal such as I-1, II-1, etc. to the "ANY" terminal and strap the second control input terminal such as, I-2, II-2, etc. to the desired control character terminal.

If a single lower case character is desired, strap the first control input terminal to lower case "LC", and strap the second control input terminal to the desired control character.

If a single upper case character is desired, strap the first control input terminal (I-1, II-1, etc.) to the upper case "UC" terminal, and strap the second control input terminal to the desired control character terminal.

#### (2) Two Characters

Strap the first control input terminal (such as I-1, II-1, etc.) to the first control character of the sequence, and strap the second control input terminal (such as I-2, II-2, etc.) to the second control character of the sequence.

An example would be I-1 to "F" and I-2 to "O", thus giving the two-character control code sequence of "FO" for a single teleprinter selection.

#### (3) Six Characters and Combinations

A six character Call Directing Code can be assigned to a single station, permitting many individual teleprinters to be selected. Strap the Call Directing Code as described below, using Figure 4-2 as a reference.

- First character to V-1.
- Second character to V-2, 62 to IV-1.
- Third character to IV-2, 59 to II-1.
- Fourth character to III-2, 56 to II-1.



March 1, 1975

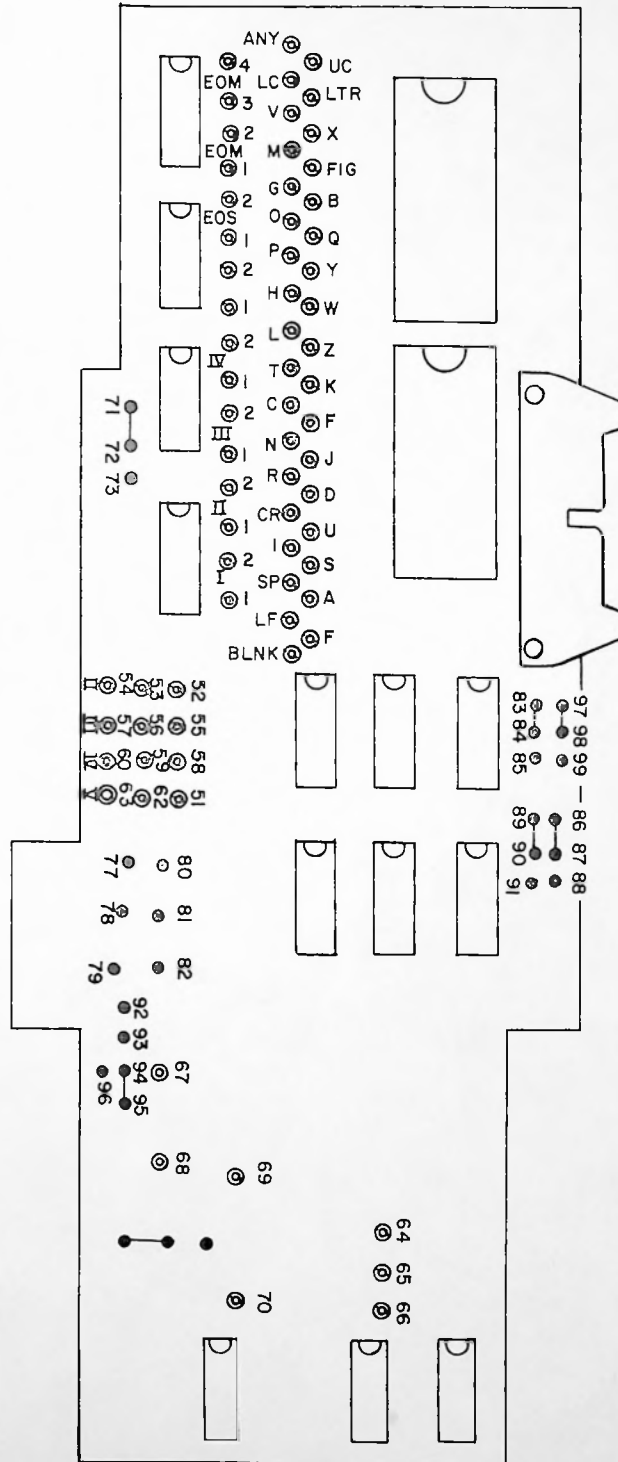

Figure 4-2. 7305 Selective Calling Strapping Points



March 1, 1975

- Fifth character to II-2, 53 to I-1.
- Sixth character to I-2.

#### c. Station Selection

This requires a unique code which is assigned to a specific teleprinter. It can be one to six control characters in length, as described previously in section on CDC's. Control inputs I-1 and I-2 are normally used for one- or two-character codes; a six-character code requires the use of all control input terminals. Other combinations that can be used are one five-character CDC plus one two-character CDC; one four-character CDC plus one three-character CDC; and two three-character CDC's plus one two-character CDC.

#### d. Group Selection

One- or two-character sequence CDC codes can be assigned to each teleprinter station to select a group of teleprinters. A station may have up to four different group code assignments, but remember only one teleprinter within each group may be assigned the answerback function.

- The first code assignment is made by strapping control input terminal II-1 and II-2 to the desired two-character sequence, as previously described, and strapping printer-select terminals 53-54 for station printing. If the optional ACK feature is required, terminals 52-53 must be strapped.
- A second code assignment can be made by strapping terminals III-1 and III-2 to the desired two-character sequence. Also strap terminals 56-57 for station printing and terminals 55-56 if an ACK is required.
- A third code assignment can be made by strapping terminals IV-1 and IV-2 to the desired two-character sequence. Also strap terminals 59-60 for station printing and terminals 58-59 if an ACK is required.
- A fourth code assignment can be made by strapping group terminals V to the desired two-character sequence. Also strap terminals 62-63 for station printing and terminals 61-62 if an ACK is required.

#### e. Remote or Auxiliary Receiver Selection

Provision is made on the selective calling board for a discrete CDC code to turn on and off a remote auxiliary receiver, such as a paper tape punch. A one- or two-digit Call Directing Code can be assigned to activate the remote receiver. This code is wired from terminals V-1 and V-2 (REMOTE) to the desired control characters mentioned in the Group Selection Paragraph above. Before attempting to perform the following strapping requirements, ascertain that the teleprinter has been factory programmed to implement the remote receiver feature.

- Terminals 62-63 are strapped to activate the station printer and terminals 61-62 are strapped if an ACK is required.
- A high-level polarity output is provided when terminals 86-87 are strapped.
- A low-level polarity output is provided by strapping terminals 87-88.
- If terminals 80, 81, or 82 are not strapped, the remote receiver will be enabled upon receipt of the CDC. If it is desired that the remote receiver be enabled 250 ms after receipt of CDC, terminals 81 and 82 are strapped. For the remote receiver to be enabled upon the receipt of an "EOS", strap terminals 80-81.

#### f. Auxiliary Transmitter Polling

A provision is made on the selective calling board for a discrete TSC (Transmitter Start Code) to operate an associated transmitter, such as a tape reader. Before performing the following strapping instructions, ascertain that the teleprinter has been programmed to implement this feature.

- Strap terminals IV-1 and IV-2 (TRANSMIT) to the desired two-character sequence mentioned in the Group Selection paragraph above.
- If printing of the Auxiliary Transmitter's message is desired, strap control code terminals 59-60.
- An acknowledgement is provided by strapping terminals 58-59.



g. End of Selection Code (EOS)

This is a two-character code which: (1) switches selected teleprinters to the "print" mode, (2) places unselected teleprinters in the "non-print" condition and (3) inhibits recognition of any further call directing codes. Programming of the EOS code requires two-control characters in sequence as follows:

- Strap EOS-1 to the first control character of the sequence.
- Strap EOS-2 to the second control character of the sequence.

h. End of Message Code (EOM)

A maximum of four control characters can be used for the End Of Message code (EOM) which conditions all teleprinters on the system loop to the "select" mode before any messages are received. When a four control-character sequence is used for the EOM code, strap each EOM terminal to the desired control character. If a two-character sequence EOM code is desired, strap terminals EOM-1 and EOM-2 to the "any" terminal, the first control character (or U.C.) to EOM-3, and EOM-4 to the second control character.

i. Answerback (ACK) Programming(1) Group Codes

When assigning group codes for specific teleprinters, the acknowledgement (ACK) strapping is optional. The strapping for this feature has been previously described under the Call Directing Codes paragraph.

(2) Acknowledgement Polarity

The teleprinter is factory-strapped to provide a negative-going acknowledgement polarity signal on the "ACK output line", and pads 74-75 have been strapped to achieve this. For a positive-going acknowledgement polarity signal, remove the strap between pads 74-75, and strap pads 75-76. If no acknowledgement signal is required, remove the strap between pads 74-75.

(3) Acknowledgement Timing

The length of the acknowledgement answerback can be controlled either by the remote end-period signal (negative or positive) or the low paper alarm contacts. However, the teleprinter is always factory-programmed for remote end-period signal control. With the remote end-period signal control, resistor R9 is normally selected for four-bit intervals at the lowest operating Baud rate, resulting in a "V" or "M" acknowledgement. A negative-going remote end-period signal is provided when pads 94-95 are strapped, and a positive-going remote end-period control signal when pads 93-94 are strapped. For low paper alarm control, pads 92-93 are strapped, and the strap between pads 94-96 is removed. Resistor R9 is selected for 2 bit intervals at the operating Baud rate for a "V" ACK and resistor R11 is selected for 3 bit intervals for a "M" NACK when the low paper alarm grounding contact is connected to input terminal 5.

j. Selective Calling Board Access

To gain access to the Selective Calling Printed Circuit Board within the teleprinter's electronics base, follow the instructions on Internal Access contained in Paragraph 2-11b of Section 2 of this manual.

