

# CartGuys

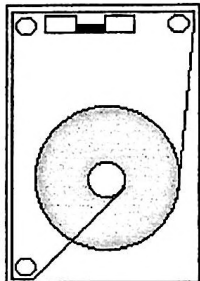

[www.cartguys.com](http://www.cartguys.com)

3420 N. Flanwill Avenue

Tucson, AZ 85716

Phone: +1 520-327-4466

Fax: +1 509-694-1545

## **DYNAMAX®**

### **Professional Broadcast Products**

## **TECHNICAL MANUAL**

### **DYNAMAX**

### **CTR10 SERIES**

**NAB TAPE CARTRIDGE  
RECORDER/REPRODUCER  
SYSTEM**

**INCLUDING:**

**CTR11 - A Size Mono Play**

**CTR12 - A Size Stereo Play**

**CTR13 - A Size Mono Record/Play**

**CTR14 - A Size Stereo Record/Play**

P/N 730-A0-015

Revision 8/00

## DYNAMAX

BROADCAST PRODUCTS BY FIDELIPAC

Fidelipac Corporation

P.O. Box 808

Moorestown, NJ 08057 USA

Phone: 609-235-3900

FAX: 609-235-7779

## ADDENDUM

In our continuing effort to improve our products, this machine includes a newly designed Head Bridge Assembly which offers greater stability in addition to simplified head alignment. Please disregard the following technical manual sections and use the procedures contained in this Addendum:

CTR100 Series	Sections 4.5 thru 4.6.4
CTR10 Series	Sections 4.5 thru 4.6.4
ESD10	Sections 4.5 thru 4.5.3

In addition, please replace the Bill of Materials and the mechanical drawings for the Head Bridge Assembly with the ones included with this addendum.

CTR100 Series  
CTR10 Series  
ESD10  
Revised 12/91

## TAPE GUIDE ALIGNMENT

Using the Tape Guide/Head Alignment gauge, align the tape guides by turning the tape guide adjustment screw so that the inside edge of the upper guide finger just contacts the top of the height gauge (see drawing 750-A0-440 sheet 2). Repeat for the other guide(s). Note: there are normally 2 Tape Guides on each unit, however, an optional Center Tape Guide is available.

**NOTE:** Worn guides may seriously affect stereo phase performance. Guides should be checked periodically for signs of wear and replaced when necessary.

## HEAD ALIGNMENT

The Head Bridge includes alignment in four axes: Height, Azimuth, Zenith, and Insertion.

Remove the machine's outer cover, permitting access to the Head Block.

**NEVER FORCE HEAD ALIGNMENT  
SCREWS**

## INSERTION

To adjust Insertion for most common cartridges, insert a Fidelipac Model 328 Head Insertion Gauge cartridge into the machine.

Adjust Tape Heads for equal penetration within limits of scribe marks on cartridge cover as viewed from directly above.

## HEIGHT & ZENITH

Loosen the .050" Allen head locking screws on each side of the head block 1/4 turn.

Height and Zenith alignments should be performed with the machine turned off.

As shown in drawing 750-A0-440 sheet 2, place a HG-1 Head Height & Zenith Gauge against the head to be aligned.

Using a Phillips screwdriver, adjust the Height alignment screw such that the top edge of the top track pole piece is aligned with the top of the HG-1.

Using a Phillips screwdriver, adjust the Zenith alignment screw such that the vertical front surfaces of the head and HG-1 are parallel.

Recheck both Height and Zenith alignments.

Repeat the above procedure for the second head.

Retighten both head locking screws.

**BE SURE TO DEMAGNETIZE THE  
HEADS BEFORE USING THE MACHINE.**

**NOTE:** Head Height will be peaked during electronic adjustment.

## AZIMUTH

Azimuth alignment is normally performed during reproduce and record alignments.

A 5/64" Allen head driver is required to adjust the Height alignment screws.

**NOTE:** Stereo Azimuth alignments are most easily accomplished using either a dual trace oscilloscope in the dual trace "chop" display mode, or a good quality phase meter.

## MONO REPRODUCE AZIMUTH

While playing the "Set Azimuth" portion of a standard Spot Frequency Alignment Cartridge, adjust Play Azimuth for a peak signal at the audio output of the machine.

## MONO RECORD AZIMUTH [Recorder Only]

Load a blank cartridge into the machine. Inject a 16 kHz signal at nominal level into the audio input and enter Record mode. Adjust Record Azimuth for a peak signal at the audio output of the machine.

## STEREO REPRODUCE AZIMUTH

While playing the "Set Azimuth" portion of a standard Spot Frequency Alignment Cartridge, adjust Play Azimuth for both peak and in phase signals at the audio outputs of the machine.

## STEREO RECORD AZIMUTH [Recorder Only]

Load a blank cartridge into the machine. Inject a 16 kHz signal at nominal level into both audio inputs and enter Record mode. Adjust Record Azimuth for both peak and in phase signals at the audio outputs of the machine.

ALL ADJUSTING / LOCKING SCREWS  
 SOCKET HEAD 5/64

ZENITH ADJUSTMENT  
 SCREWS

AZIMUTH  
 ADJUSTMENT  
 SCREWS

LENGTH

AZIMUTH

HEIGHT

INSERTION  
 ADJUSTMENT  
 SCREWS  
 USE FIDELIPAC HEAD  
 INSERTION GAGE NO. J28

HEAD BRIDGE  
 MTG. SCREW (SOC. NO. 7/64)

HEIGHT ADJUSTMENT  
 SCREWS

TAPE GUIDE ADJUSTMENT  
 SCREWS

HEAD CLAMPING SCREWS  
 HEADS ARE INSTALLED SEATED AGAINST  
 CLAMPING SCREWS

TAPE GUIDE ADJUSTMENT  
 ALIGN TOP EDGE OF GUIDE WITH  
 TOP OF CAGE

PRELIMINARY TAPE GUIDE  
 HEAD ALIGNMENT GAGE  
 NO. HC-1

HEAD LOCKING SCREW  
 LOOSEN THIS SCREW (BOTH SIDES)  
 BEFORE MAKING ANY ADJUSTMENTS

HEAD HEIGHT ADJUSTMENT  
 ALIGN TOP OF TRACK WITH  
 TOP OF CAGE

HEAD ZENITH ADJUSTMENT  
 SQUARE FACE OF HEAD WITH  
 FACE OF CAGE

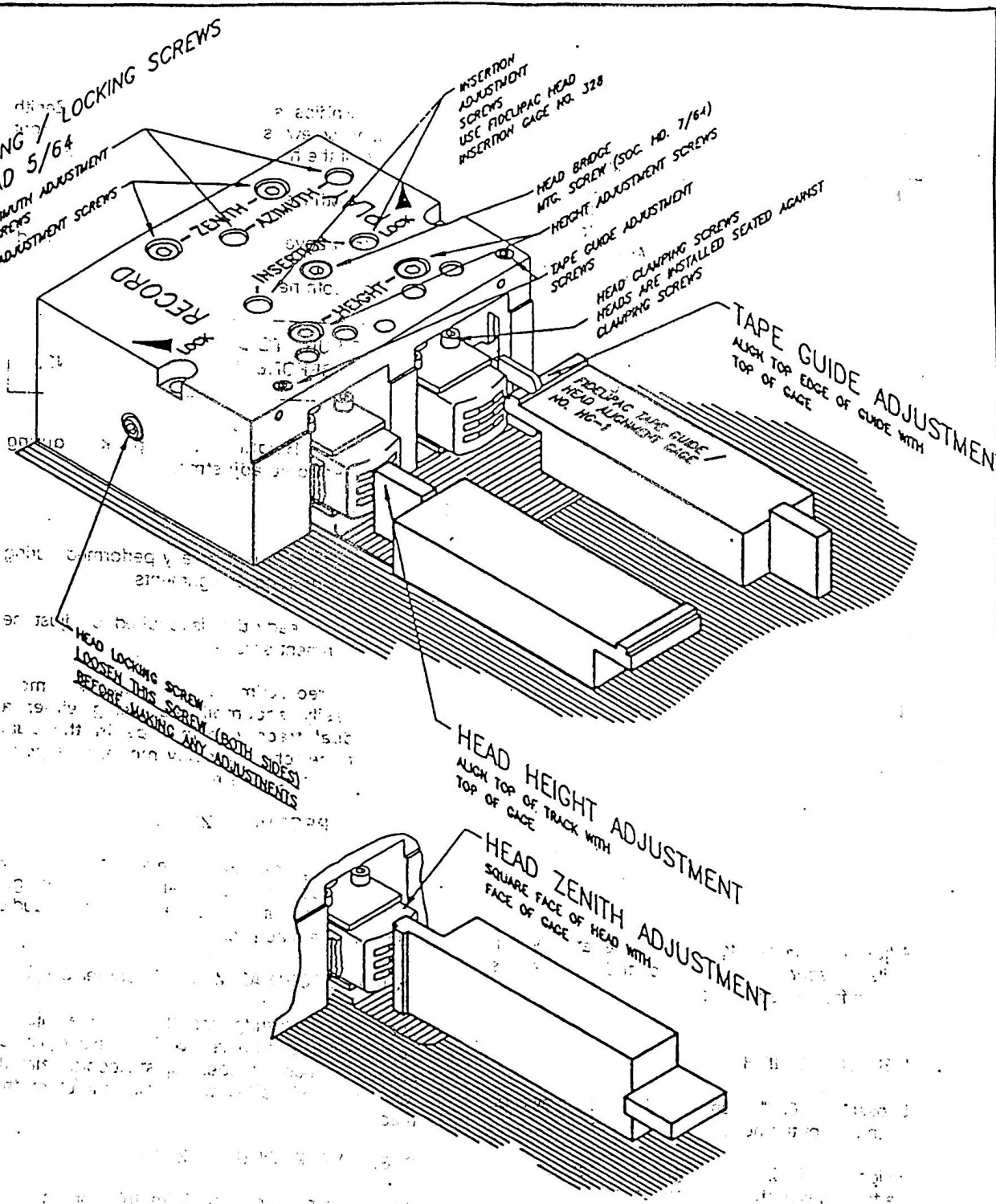

MECHANICAL ALIGNMENT LOCATIONS

DWG. NO.	750-B0-440	APPR.	J.W.
SHEET	2 OF 2	ISSUE DATE	2/6/91

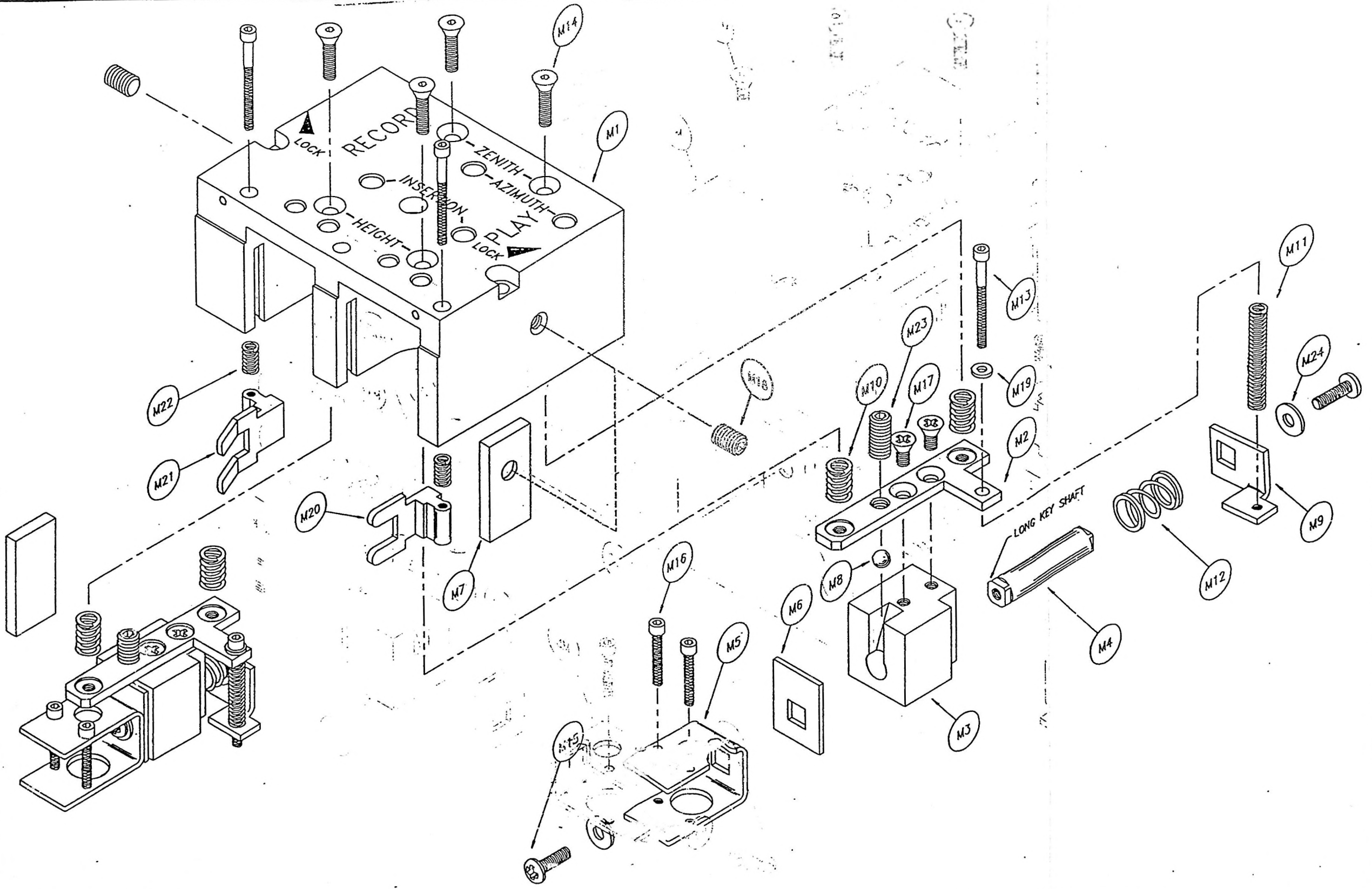

MODEL NOS.  
ALL MODELS

ASSEMBLY  
HEAD BRIDGE

DWG. NO. 827-DO-401  
SHEET 1 OF 1  
APPR. J.J.W.  
ISSUE DATE 2/6/91

FIDELIPAC CORP.  
MOORESTOWN, N.J.

THIS DOCUMENT CONTAINS PROPRIETARY INFORMATION OF FIDELIPAC CORPORATION. NO USE, DISCLOSURE OR REPRODUCTION OF ANY PART THEREOF MAY BE MADE WITHOUT PRIOR WRITTEN PERMISSION.

827A401

# CartGuys

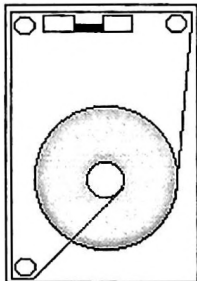

[www.cartguys.com](http://www.cartguys.com)

3420 N. Flanwill Avenue

Tucson, AZ 85716

Phone: +1 520-327-4466

Fax: +1 509-694-1545

## DYNAMAX®

### Professional Broadcast Products

## TECHNICAL MANUAL

## DYNAMAX® CTR10 SERIES

NAB TAPE CARTRIDGE  
RECORDER/REPRODUCER  
SYSTEM

INCLUDING:

CTR11 - A Size Mono Play

CTR12 - A Size Stereo Play

CTR13 - A Size Mono Record/Play

CTR14 - A Size Stereo Record/Play

P/N 730-AD-015

Revision 12/6/00

## TABLE OF CONTENTS

<b>SECTION 1</b>	<b>GENERAL INFORMATION</b>	
1.1	Introduction	1
1.2	General Description	1
1.2.1	Exclusive Features	1
1.2.2	Standard Features	2
1.2.3	Electronics	3
1.2.4	Logic (Functional Description)	3
1.2.5	Transport	4
1.2.6	CTR10 Specifications	5
1.2.7	2 Year Limited Warranty	11
<b>SECTION 2</b>	<b>INSTALLATION</b>	
2.1	Unpacking and Inspection	12
2.2	Jumper Selection	12
2.2.1	PLAY/CUE/LOGIC PWA	12
2.2.2	RECORD PWA	12
2.3	VU Meter Operation	13
2.4	Mounting	14
2.5	Wiring	14
2.5.1	Connecting AC Power	14
2.5.2	Balanced Audio Input Connections	14
2.5.3	Unbalanced Audio Input Connection	15
2.5.4	Balanced Audio Output Connections	16
2.5.5	Unbalanced Audio Output Connections	17
2.5.6	Grounding	17
2.5.7	Remote Control Wiring	18
<b>SECTION 3</b>	<b>OPERATION</b>	
3.1	Pre-Operating Procedures	20
3.2	Front and Rear Panels - Controls and Indicators	20
3.3	Normal Operation	22
3.3.1	Recording	23
3.3.2	Playback	23
3.3.3	Fast Forward	23
3.3.4	Cue Tone Recording (Recorders Only)	24
3.3.5	Playback with Audio Switcher Interlock	24
3.3.6	Multiple Machine Audio Mixing	24
<b>SECTION 4</b>	<b>MECHANICAL ADJUSTMENTS</b>	
4.1	Pressure Roller/Motor Shaft Alignment	25
4.2	Solenoid Plunger Adjustment	26
4.3	Solenoid Damping Adjustment	26
4.4	Cartridge Guidance System Alignment	26
4.5	Head Bridge Adjustments	28
4.5.1	Tape Guide Adjustment	28
4.5.2	Insertion Adjustment	28
4.5.3	Height and Zenith Adjustment	30

4.6	Head Azimuth Adjustment	30
4.6.1	Monophonic Play Head Azimuth	31
4.6.2	Monophonic Record Head Azimuth	31
4.6.3	Stereo Play Head Azimuth	31
4.6.4	Stereo Record Head Azimuth	31
4.6.5	Tape Head Replacement	31
<b>SECTION 5</b>	<b>ELECTRONIC ADJUSTMENTS</b>	
5.1	Program Playback Adjustments	33
5.1.1	Playback Equalization	33
5.1.2	Output Level	33
5.2	Cue Detector Frequency Center	34
5.3	Cue Detector Sensitivity	34
5.3.1	1 kHz Sensitivity	34
5.3.2	150 Hz Sensitivity	35
5.3.3	8 kHz Sensitivity	35
5.4	Playback Meter Adjustments	35
5.5	Record Adjustments	35
5.5.1	Bias Adjustments	35
5.5.2	Record Level	36
5.5.3	Record Equalization	37
5.6	Program Record Meter Calibration	37
5.6.1	Bias Meter Calibration	37
5.6.2	Record Level Meter Calibration	37
5.7	Cue Bias Adjustment	38
5.8	Cue Record Level	38
5.9	Cue Metering	38
<b>SECTION 6</b>	<b>CIRCUIT DESCRIPTION</b>	
6.1	RECORD PWA	39
6.1.1	Brief Description	39
6.1.2	Detailed Description	39
6.2	PLAY/CUE/LOGIC PWA	40
6.2.1	Brief Description	40
6.2.2	Detailed Description	40
6.3	MOTHER PWA	43
6.3.1	Brief Description	43
6.3.2	Detailed Description	43
6.4	Front Panel VU PWA (Recorders Only)	44
6.4.1	Brief Description	44
6.4.2	Detailed Description	44
<b>SECTION 7</b>	<b>MAINTENANCE</b>	
7.1	Normal Preventive Maintenance-Checks & Adjustments	45
7.1.1	As Required	45
7.1.2	Monthly	45
7.1.3	Every Six Months	45
7.2	Normal Preventive Maintenance	46



7.2.1	Tools	46
7.2.2	Test Equipment for Routine Alignment	46
7.3	Test Tapes and Alignment Gauges	46
<b>SECTION 8</b>	<b>TROUBLESHOOTING</b>	<b>47</b>
<b>SECTION 9</b>	<b>MECHANICAL ASSEMBLIES AND PARTS LISTS</b>	<b>48</b>
867-A0-002	Packing list for mono machines (11/12)	
867-A0-003	Packing list for stereo machines (13/14)	
847-A0-009	Top Assembly R/P Stereo	
	Incorporating: 847-A0-006	Top Assembly Play Mono
	847-A0-007	Top Assembly Play Stereo
	847-A0-008	Top Assembly R/P Mono
827-A0-018	Front Panel Assembly Play	
827-A0-020	Front Panel Assembly R/P Stereo	
	Incorporating: 827-A0-019	Front Panel Assembly R/P Mono
827-B0-000	Head Bridge Assembly	
827-B0-024	Rear Panel Assembly - 120V model	
827-A0-068	Rear Panel Assembly - 220V model	
827-B0-023	Transformer Assembly	
827-A0-022	Motor Assembly	
827-A0-021	Heat Sink Assembly	
827-A0-025	Right Bracket Assembly	
827-A0-063	Left Bracket Assembly	
827-A0-026	Deck Assembly	
<b>SECTION 10</b>	<b>ELECTRICAL SCHEMATICS AND PARTS LISTS</b>	
807-A0-061	Cartscan PWA	
807-E0-076	PLAY/CUE/LOGIC PWA Stereo	
750-F0-062	Schematic, PLAY/CUE/LOGIC PWA	
807-C0-081	RECORD PWA Stereo	
750-B0-063	Schematic, RECORD PWA	
807-A0-101	VU METER PWA Stereo	
750-A0-064	Schematic, VU METER PWA	
807-C0-065	SERVO PWA	
750-A0-212	Schematic, Servo PWA	
807-B0-105/106	Schematic, MOTHERBOARD PWA	
<b>SECTION 11</b>	<b>ADDENDA</b>	

## LIST OF ILLUSTRATIONS

FIGURE #	Description	Page
1	Balanced Audio Input Connections	14
2	Unbalanced Audio Input Connection	15
3	Balanced Audio Output Connections	16
4	Unbalanced Audio Output Connection	17
5A,5B,5C	Pressure Roller/Motor Shaft Alignment	25
6	Scribing a Cartridge	27
7	Head Bridge Adjustment	29
8	Height and Zenith Adjustment	30
9A,9B	In-Phase Display, Out-of-Phase Display	31
10	Adjust potentiometer guide	32



## Section 1 GENERAL INFORMATION

### 1.1 INTRODUCTION

This manual contains general, installation, operation and maintenance information for the Dynamax® CTR10 Series of Cartridge Recorders/Reproducers.

Section 1 contains a general description of CTR10 features, specifications, warranty and service information.

### 1.2 GENERAL DESCRIPTION

#### 1.2.1 Exclusive Features

The Dynamax® CTR10 Series represents advanced state-of-the-art development in audio tape cartridge recorders/reproducers.

Four models of the CTR10 are available:

Model	Description
CTR11	A Size Mono Play
CTR12	A Size Stereo Play
CTR13	A Size Mono Record/Play
CTR14	A Size Stereo Record/Play

CTR innovations include:

#### A. Cleaning Switch

Located just inside the cartridge opening, this switch permits the pinch roller solenoid to be activated without inserting a cartridge, thus allowing the pressure roller to be cleaned from the front of the machine.

#### B. Azimuth Independent Head Bridge

The head bridge mounts to the transport with three screws. Locks are provided for the height and zenith adjustments. Azimuth adjustment does not affect height or zenith. The front surface of the bridge provides flat and precisely vertical reference to the cartridge. There are no screws along the front cartridge reference surface. This design provides for precise head penetration. The head bridge incorporates micro adjustable tape guides with vernier self-locking height adjustment screws.

#### C. Cartridge Positioning System

Four molded rubber rollers place downward pressure on the upper edges of the cartridge. Their canted design helps insure that the cartridge is aligned along the right cartridge guide. The flat and vertical front reference surface of the head bridge permits the cartridge to align squarely.

## 1.2.2 Standard Features

The CTR10 provides a number of additional features:

- A. Fast Forward
- B. Secondary and Tertiary Cue Tones
- C. Regulated Low Voltage Solenoid
- D. Audio Switcher and Mixer
- E. Transformerless Audio Inputs and Outputs
- F. 150 Hz Control of Audio Muting (Strappable for beginning or end of tone)
- G. 150 Hz Initiation of Fast Forward (Strappable for beginning or end of tone)
- H. Constant Current Record Amplifier (Recorders Only)
- I. Separate Low Frequency and High Frequency Playback Equalization Controls (Recorders Only)
- J. Front Panel 1 kHz Tone Defeat (Recorders Only)
- K. Full Metering with Automatic Record/Play Changeover (Recorders Only)
- L. Flashing "Cart Played" Indicator
- M. Strappable Repeat Play Disable
- N. Active Bias and Signal Mixing (Recorders Only)
- O. Bar Graph LED Level Indicators (Recorders Only)
- P. High Performance Heads for Flat Frequency Response, Low noise
- Q. Fast Forward Audio Un-Mute Control
- R. Self-Aligning Ball-Bearing Pressure Roller
- S. Electrolyzed Stainless Steel Capstan

### 1.2.3 Electronics

The electronics utilize mother/daughter board construction eliminating the need for a wiring harness. The solenoid, motor, power transformer, front panel and rear panel are also connectorized to facilitate servicing. Circuit boards are G10 fiberglass epoxy with gold plated fingers. In addition, the circuit board connectors are gold plated. All integrated circuits are socketed for easy servicing. The state-of-the-art electronic components utilized in the audio circuitry provide excellent noise, transient response and dynamic range performance. Low frequency and high frequency playback equalization controls are provided, allowing for optimization to any equalization standard. Differentially balanced transformerless outputs result in better frequency response, phase and transient performance.

The transformerless record circuits accept input levels as low as -22 dBm. The record bias and audio are actively summed eliminating the need for adjustable bias traps. The head drive circuit is unique and innovative. The tape head is always under constant current operation. It is a part of the feedback loop of the drivers.

The combination of the record head and special reproduce head produces frequency response comparable to that of open reel recorders. The result is crisp, clean audio with excellent response, noise, transient, and distortion characteristics. The magnetic tape and cartridge become the only limiting factors.

### 1.2.4 Logic (Functional Description)

The logic circuitry utilizes CMOS devices resulting in low power consumption and excellent noise immunity.

#### A. STOP Lamp

Indicates whether a cartridge is ready to play (lamp stays on) or has been played (lamp flashes). A user selected jumper can be used to inhibit the START switch when the stop lamp is flashing.

#### B. Secondary and Tertiary Cue Tones

Standard feature. Front panel indicators illuminate when a tone is present. Relay contacts are provided for remote tone sensing. Tones may be recorded in the RECORD or START mode.

#### C. FAST FORWARD

Standard feature. When initiated, the audio is muted automatically. Holding the FAST FORWARD button will unmute the audio. A user selected jumper may be used to initiate FAST FORWARD at the beginning or end of the Secondary tone.

#### D. 1 kHz Stop Tone

The tone will automatically be recorded at the beginning of a new recording. To defeat this function, press the RECORD switch twice prior to starting the machine. A front panel indicator will illuminate indicating 1 kHz DEFEAT.

#### E. Audio Switcher

The AUDIO front panel indicator will illuminate when the START button is pushed. Entering any other mode of operation will turn off the Audio Switcher. The Audio Switcher remote control terminals from several machines may be interconnected allowing interaction between machines.

Under this configuration, the last machine started would mute the audio output of all other machines.

#### F. Front Panel LED VU Meters

The meters monitor the audio levels and may also be used to display left and right record bias, cue record bias and cue signals. There are two selectable modes of audio monitoring available:

1. AUTO I - meters show audio output and automatically switch to record input while in RECORD mode.
2. AUTO II - meters show record input only when in RECORD and STOP mode (record ready). Automatically switch to audio output at all other times. This function allows the recording level, to be preset and then automatically switches to give an off-the-tape indication during the recording process.

#### 1.2.5 Transport

The transport is constructed around a precision-machined 1/2 inch thick anodized aluminum deck plate for mechanical stability and plated with a hard electrolysis nickel finish to resist wear.

A heavy-duty two inch air damped solenoid is utilized with a chain driven pressure roller assembly. The solenoid is a low voltage DC device which is controlled with a two-step circuit. This circuit insures fast starts and then reduces solenoid current.

#### A. Pressure Roller

The pressure roller assembly includes a ball-bearing race providing self-alignment to the capstan shaft. This eliminates tape skew when the cartridge is first started, and eliminates keystoneing due to roller wear or motor mis-positioning.

## B. Motor

The motor is a DC servo controlled device utilizing a precision non-magnetic stainless steel capstan shaft. The steel capstan eliminates the static and cleaning problems associated with ceramic capstans.

## C. Head Bridge

Made from a precision three-piece die-casting. The azimuth adjustment is independent of the height and zenith adjustments. Height and zenith adjustments are locked into position after setting.

The tape guides are an integral part of the Head Bridge and may be precisely adjusted in the vertical plane by turning one screw for each guide. This design has eliminated the need for tape guide holding screws along the front of the Head Bridge, resulting in an accurate front cartridge reference. The Head Bridge mounts to the transport with two screws and may be removed from the transport without upsetting previous head adjustments.

## D. Cartridge Positioning System

This system is unique. It utilizes four molded rubber rollers in a canted design in conjunction with stainless steel wire springs. These rollers place downward pressure on the cartridge edges and help to insure that the cartridge is aligned along the right cartridge edge guide. The familiar and often troublesome micro switch has been replaced with optical cartridge sensors.

### 1.2.6 CTR10 Specifications

#### A. Power

1. 117 VAC plus or minus 10%
2. 60 Hz
3. 70 watts maximum
4. Other voltages and frequencies on request

#### B. Tape Speed

STANDARD

7.5 i.p.s. (19 cm/s)

FAST FORWARD

22.5 i.p.s. (57 cm/s)



C. Capstan Motor Drive System

1. Direct drive capstan
2. Servo driven DC Motor
3. Electrolyzed stainless steel shaft/capstan non-magnetic
4. Permanently lubricated ball bearings

D. Wow & Flutter

Record/Play maximum  
0.12% DIN PEAK WTD at 7.5 i.p.s.

E. Speed Accuracy

Better than plus or minus 0.2%

F. Audio Output and Source Impedance

Differentially balanced source impedance 440 ohms; RF bypassed

G. Audio Output Level

+20 dBm into 600 ohms before clipping

H. Distortion

1. Reproduce amplifier:

- a. 0.1% THD maximum at +18 dB above 250 nWb/m

2. System distortion, tape limited:

- a. 0.5% maximum 2nd or 3rd harmonic
- b. 1.0% THD maximum, Ref 1 kHz at 250 nWb/m

## I. Noise

### 1. Signal/noise measured with bias/no signal at 7.5 i.p.s.

Mono: -57 dB or better

Stereo: -85 dB or better

### 2. Hum and Noise - no tape

Mono: -60 dB or better

Stereo: -58 dB or better

### 3. Squelch noise -70 dB or better

NOTE: Measured over a 20-20 kHz bandwidth, reference 250 nWb/m at 1 kHz

## J. Crosstalk

Within 50 dB minimum separation between program channels at 1 kHz

## K. Frequency Response

$\pm 1.5$  dB 50 Hz - 16 kHz

## L. Equalization

1. 1975 NAB EQ Standard normally supplied 7.5 i.p.s.

2. IEC Standard on request (pot adjustment) 7.5 i.p.s.

3. Field strappable for 1964 NAB EQ

4. Adjustable low and high frequency playback EQ

5. Adjustable high frequency record EQ

## M. Head Configuration

NAB, Mono/Stereo

#### N. Cue Signals

1. NAB primary cue 1 kHz
2. NAB secondary cue 150 Hz with front panel indicators
3. NAB tertiary cue 8 kHz with front panel indicators
4. Open relay contacts available upon sensing secondary or tertiary cue tones (contacts close with tone present)

#### O. Logging Signals

1. Not internal to machine
2. Cue audio input, cue audio output and cue track bias control available via remote control connector
3. Output level 0.5v nominal from a logging signal of 35 nWb/m tape fluxivity
4. Logging output impedance 1k ohms
5. Cue audio input 0.5v nominal
6. Input impedance 47k ohms

#### P. Audio Input Level

1. -22 dBm minimum
2. +20 dBm maximum

#### Q. Audio Input Configuration

Differentially balanced bridging 10k ohms

#### R. Metering

1. Audio Metering, Jumper Selectable
  - a. AUTO I - monitors record input level when bottom deck is in RECORD mode, automatically switches to output level at all other times.
  - b. AUTO II - monitors input level when machine is in RECORD and STOP (ready) mode, automatically switches to output level at all other times.

2. Test Metering, Switch Selectable

- a. Left program bias displayed on left meter; right program bias displayed on right meter
- b. Cue bias displayed on left meter; cue audio displayed on right meter

S. Bias Oscillator

120 kHz

T. Tape Capacity

NAB sizes A and AA

U. Start Time

Typically 100 milliseconds (timing dependent upon solenoid air damping adjustment)

V. Stop Time

Tape stop time typically 100 milliseconds (dependent on type and length of cartridge)

W. Ambient Operating Temperature Range

10-50 degrees C (50 degrees to 122 degrees F)

X. Remote Control Signals

- 1. All front panel controls and indicators (except record input controls and meters)
- 2. Cue track input, output and bias control
- 3. Automation Ready, Audio Switcher Interlock

## Y. External Connectors

1. 9 pin D audio connectors (mating connectors supplied)
2. 50 pin D - remote control (mating connector supplied)
3. Plug-in line cord with IEC type connector

## Z. Mounting

1. Table top standard
2. Rack mount (optional rack mount available)

## AA. Ordering Information and Dimensions

MODEL NO.	DESCRIPTION	DIMENSIONS		
		Height	Width	Depth
CTR11	A Size Mono Play	14.29 cm 5.625 in.	15.24 cm 6.00 in.	40.64 mm 16.00 in.
CTR12	A Size Stereo Play	14.29 cm 5.625 in.	15.24 cm 6.00 in.	40.64 mm 16.00 in.
CTR13	A Size Mono Record/Play	14.29 cm 5.625 in.	15.24 cm 6.00 in.	40.64 mm 16.00 in.
CTR14	A Size Stereo Record/Play	14.29 cm 5.625 in.	15.24 cm 6.00 in.	40.64 mm 16.00 in.

## BB. Shipping Information

MODEL NO.	MAXIMUM SHIPPING WEIGHT		MAXIMUM SHIPPING VOLUME	
	Pounds	kg.	cu. ft.	cu. m.
CTR11	27	12.25	1.4	0.04
CTR12	27	12.25	1.4	0.04
CTR13	28	12.70	1.4	0.04
CTR14	28	12.70	1.4	0.04

## 1.27 2 Year Limited Warranty

CartGuys Inc., warrants that new equipment sold is free of defects in workmanship or material for a period of two years from date of shipment. This warranty applies only to the original user and excludes wear items such as bulbs, fuses, heads, rollers, etc.

To register as the original user, please send a letter to CartGuys, at the address on the front page of this manual, with your name/address/phone number/date of purchase. If we do not receive such notification, claims may not be recognized.

Other manufacturers' equipment, such as motors and heads, bear only those manufacturers' standard warranty and no other warranty.

Warranty claims will be honored only if written notice is received by CartGuys within thirty days after discovery of a defect, and prior to return of equipment to us. Our only obligation will be to repair or replace, at our option, the item or part FOB the factory or other designated location. Returned equipment must be adequately packed and insured to protect against shipping damage and delivered to our factory by prepaid transportation for inspection and testing.

Overseas customers should contact the factory for specific instructions regarding warranty service.

In most cases, modules, sub-assemblies or other parts may be exchanged, thus reducing the expense and inconvenience of returning a complete unit.

This warranty is limited to normal and correct use and service of equipment, and is not valid if defects result from maltreatment, exposure, excessive moisture or heat, or operation under environmental or other conditions apart from those prescribed in the equipment instruction manual. Moreover, this warranty will be void if equipment is altered or repaired without specific written authorization by CartGuys.

*The full extent of the buyer's rights and remedies are stated above. No other Warranties are expressed or implied, nor is any other private party authorized to provide any additional guarantee or warranty. CartGuys, Inc., disclaims any liability for incidental or consequential damages, or for damages or expense arising directly or indirectly from the use of this equipment, or inability to use it, or for any other reason.*

SECTION II

## SECTION 2 INSTALLATION

This section provides information about unpacking and inspection, jumper selection for restart inhibit, Fast Forward control, audio switcher control, meter switch selection, mounting and wiring.

### 2.1 UNPACKING AND INSPECTION

The CTR10 is carefully shipped in a carton to protect the equipment during transit. Carefully unpack the unit using care to avoid damage to the unit's finish. Check the contents and condition of the packing carton for any damage that may have occurred during shipment. If any damage is noted, notify the carrier of any damage. All packing material should be retained for inspection by the carrier. It is advisable to retain the carton for future use.

### 2.2 JUMPER SELECTION

#### 2.2.1 PLAY/CUE/LOGIC PWA

- A. Restart Disable jumper W1  
Position "A": Normal Operation (factory supplied).  
Position "B": Inhibits start switch if the stop lamp is flashing.

NOTE: W1 must be installed in either position "A" or "B."

- B. Audio Mute Control jumper W2,  
Position "A": Mute audio at beginning of the secondary tone.  
Position "B": Mute audio at the end of the secondary tone.
- C. Fast Forward Initiate jumper W3.  
Position "A": Initiate fast forward at the beginning of the secondary tone.  
Position "B": Initiate fast forward at the end of the secondary tone.
- D. Jumper W4 is not used.

#### 2.2.2 RECORD PWA

- A. Record Low Frequency Response W1 & W2.  
When W1 & W2 are installed (as supplied) the machine will record in accordance with the 1975 NAB Standard equalization curve. Removing W1 & W2 will provide a 3 dB boost at 50 Hz in accordance with the 1964 NAB Standard.

NOTE: Your test tape will indicate which Standard was used when it was recorded.

$\infty$  and 50 uS = 1975 Standard

3180 and 50 uS = 1964 Standard



- B. Audio Metering Select jumper W3  
Position "A": Auto II (Factory Supplied)  
Position "B": Auto I

NOTE: W3 must be installed in either position "A" or "B".

### 2.3 VU METER OPERATION

The VU meters may be used to monitor audio record bias, cue record bias and cue signals as test functions in addition to conventional program audio on record and monitoring of playback modes.

The test functions are discussed in Section 5.

Meter select switch SW1 is located on the RECORD board and may be accessed by removing the circuit board cover. There are two choices of audio metering, selected by jumpers on the RECORD PWA (See section 2.2.2).

1. AUTO I - automatically switches to audio input when the machine is in the RECORD mode, meters audio output at all other times.
2. AUTO II - automatically switches to audio input when the machine is in the RECORD and STOP mode (set level), meters audio output at all other times. This mode allows the record level to be preset and then gives an off-the-tape indication during the record process.

Carefully replace the circuit board cover.

### 2.4 MOUNTING

The Dynamax CTR10 Series is designed for table top mounting. An optional rack adapter and filler panels are available for mounting in a standard EIA 19 rack. The CTR10 series of machines are 5 1/4 high (without feet). The A size reproducers and recorders are 5.875 wide, allowing three machines to be installed side by side in a 19 rack opening.

When mounting the equipment, allow sufficient space at the top, bottom and rear of the unit to permit a flow of cooling air. For this reason, desk mounted units should not have the feet removed. Ventilation holes in the top and bottom covers should not be obstructed.

## 2.5 WIRING

### 2.5.1 Connecting AC Power

Main AC power is connected to the unit through a power supply AC cable equipped with standard connectors. To attach the cable, simply insert the female plug at one end of the cable to the male AC power receptacle on the rear panel, being certain to press the connector well into the socket on the machine. The other end of the cable may be plugged into a standard AC outlet.

### 2.5.2 Balanced Audio Input Connections

Audio input is through the female 9 pin D connector supplied with the unit.

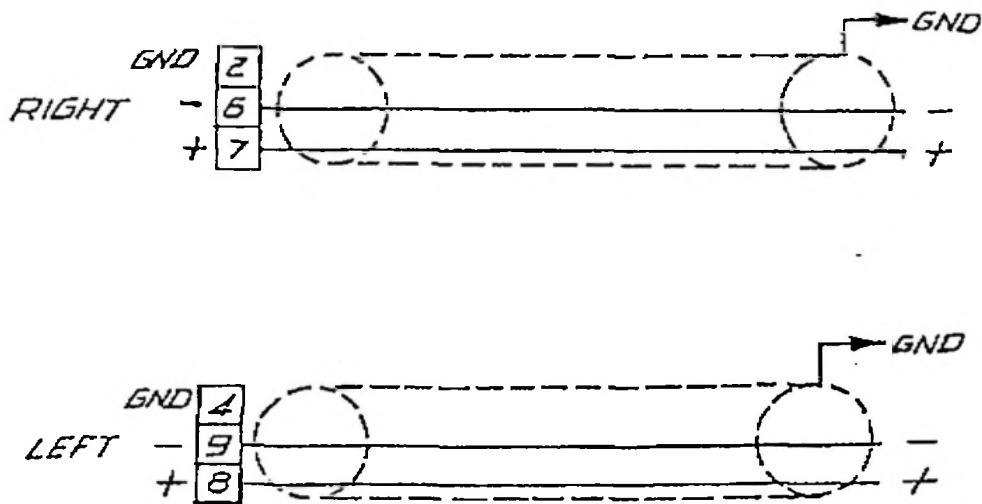

Figure 1

- NOTES: 1. This is a bridging input. Some audio sources (especially transformer coupled) require proper termination for flat frequency response and proper output level.
2. For Mono units, refer to left channel.

### 2.5.3 Unbalanced Audio Input Connection

Audio input is through the female 9 pin D connector supplied with the unit.

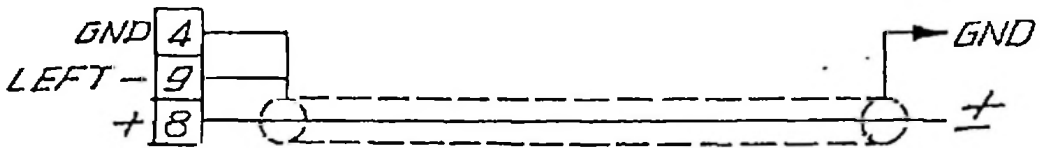
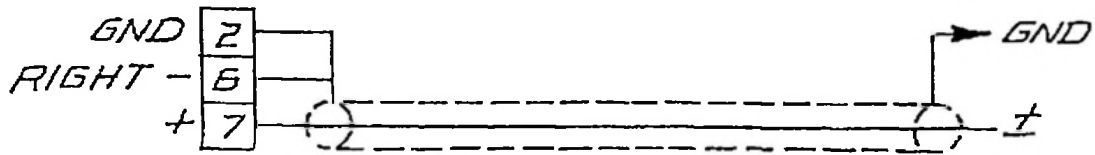

Figure 2

NOTE: This is a bridging input. Some audio sources (especially transformer coupled) require proper termination for flat frequency response and proper output level.

### 2.5.4 Balanced Audio Output Connections (3)

Audio output is through the male 9 pin D connector supplied with the unit.

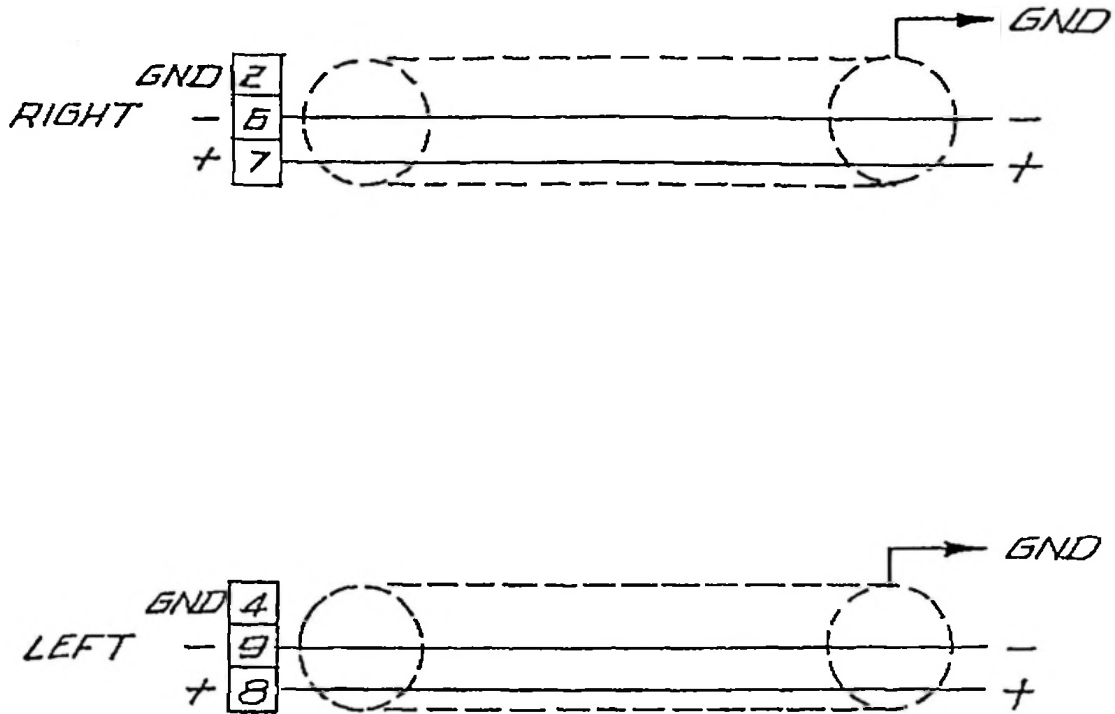

Figure 3

NOTE: If the load is a bridging input (not 600 ohms) add a 600 ohm Resistor from the + to the - terminal.

### 2.5.5 Unbalanced Audio Output Connections (3)

Audio output is through the male 9 pin D connection supplied with the unit.

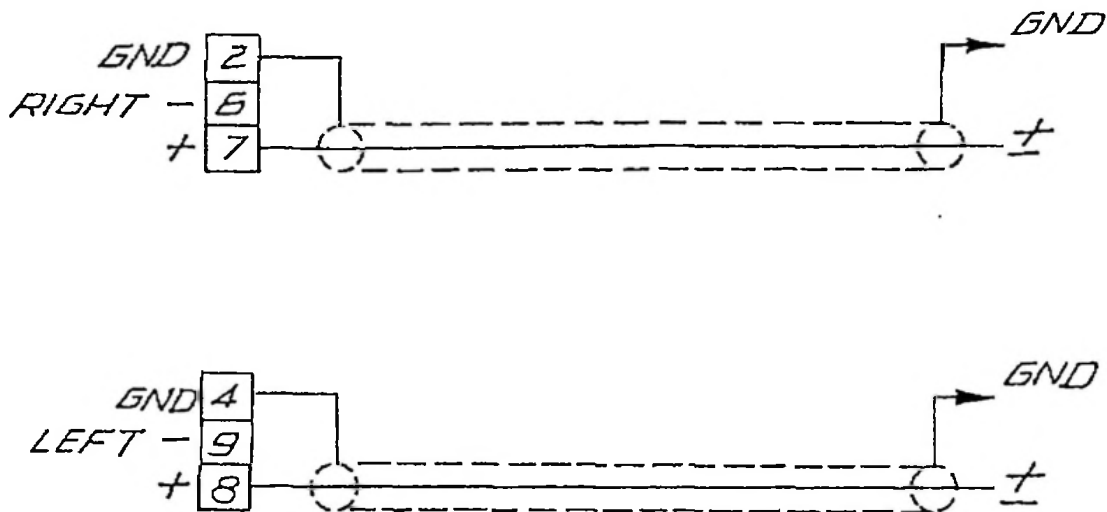

Figure 4

NOTE: If the load is a bridging input (not 600 ohms) add a 600 ohm Resistor from the + to the - terminal.

### 2.5.6 Grounding

Proper grounding is important to prevent RF pickup and ground loops. A grounding strap should be connected from the rear panel ground terminal to the studio or station ground. Most hum and noise problems can be corrected by improving or altering the grounding. If a hum loop or RF pickup occurs, one or more of the following suggestions will usually cure the problem:

- A. Use a "3 to 2" AC line adapter to lift the power line ground. Make sure that the studio ground is connected to the ground terminal of the machine. Always remove this adapter when servicing the cartridge machine.
- B. When the audio output is connected to a balanced line, a console for example, connect the shield only at the cartridge machine or only at the console. Common practice is to tie all shields to the console ground.

- C. Remove the ground shield wire from the 9 pin D connector and connect it to the chassis screw adjacent to the connector. Keep this drain wire as short as possible.

### 2.5.7 Remote Control Wiring

Remote control connections are made through the 50 pin D connector. Make connections only to designated pins.

NOTE: The machine is fully functional upon removal of the remote control plug. No jumpers are required to operate without the remote control.

CTR10	
Pin Number	Function
1-3	Not Used
4	GROUND
5	+ 15 VDC
6-17	Not Used
18	SECONDARY RECORD switch - contact to ground will record a secondary cue tone.
19	FAST FORWARD lamp - open collector current sinking output, maximum 15 VDC open circuit voltage, 80 mA.
20	FAST FORWARD switch - momentary contact to ground will place the machine in the FAST FORWARD mode. Holding contact to ground will unmute audio during FAST FORWARD operation.
21	STOP lamp - open collector current sinking output, maximum 15 VDC open circuit voltage, 80 mA. This lamp illuminates and flashes in synchronization with the front panel STOP lamp.
22	STOP switch momentary contact to ground will stop the machine.
23	START lamp - open collector current sinking output, maximum 15 VDC open circuit voltage, 80 mA.
24	START switch momentary contact to ground will start the machine.

CTR10	
Pin Number	Function
25-33	Not Used
34	GROUND
35	GROUND
36	+15 VDC
37	Cue bias - contact to ground will turn on the cue record bias.
38	Cue audio input - logging input to the cue record amplifier.
39	Cue track out - audio output from the cue track booster amplifier. Maximum load 4.7 k ohms.
40	TERTIARY cue relay - normally open contact (see pin 41).
41	TERTIARY cue relay - normally open contact (see pin 40).
42	SECONDARY cue relay - normally open contact (see pin 43).
43	SECONDARY cue relay - normally open contact (see pin 42).
44	READY lamp - open collector current sinking output, maximum 15 VDC open circuit voltage, 80 mA. This output goes low when a cartridge is inserted and is in the Stop/Ready mode.
45	Audio switcher interlock - connecting this pin with the same pin of other machines will interlock the audio switchers. Only the last machine started will pass audio; all others will be muted.
46	1 kHz DEFEAT lamp - open collector current sinking output, maximum 15 VDC open circuit voltage, 80 mA.
47	AUDIO lamp - open collector current sinking output, maximum 15 VDC open circuit voltage, 80 mA.
48	RECORD lamp - open collector current sinking output, maximum 15 VDC open circuit voltage, 80 mA.
49	RECORD switch - momentary contact to ground will place the machine into record. Second contact initiates 1 kHz DEFEAT.
50	TERTIARY record switch - contact to ground will record tertiary cue tone.

SECTION III



## SECTION 3 OPERATION

This section describes functions and location of the recorder/reproducer controls and indicators, and provides general pre-operating procedures and operating instructions for various modes of operation.

### 3.1 PRE-OPERATING PROCEEDURE

- A. Turn off the CTR10 rear panel power switch. Clean and demagnetize the components in the tape path.
- B. Make all required connections and complete all installation procedures before applying power to the unit.
- C. Turn the rear panel power switch to the on position.

### 3.2 FRONT AND REAR PANELS - CONTROLS AND INDICATORS

- |                 |   |
|-----------------|---|
| A. POWER Switch | Located on the rear panel of the unit. Used to turn AC power on and off.  |
| B. STOP Switch  | Used to stop all tape motion and to cancel the RECORD set mode.   |
| C. READY Lamp   | Contained in the STOP switch, the READY lamp is on when the cartridge is properly loaded or when the cleaning switch is on, indicating that the machine is ready to start. The READY lamp will flash after the cartridge has cued or if the cartridge has been manually stopped.  |
| D. START Switch | Used to place the transports into motion. The START mode may be entered from the FAST FORWARD or STOP modes. When starting from the STOP mode, the READY lamp must first be illuminated. When entering the START mode from FAST FORWARD, the audio will remain muted until normal speed is achieved. The machine will remain in the START mode until another mode is selected or a STOP tone is reached. See Section 2.2.1. |
| E. START Lamp   | Contained in the START switch, this lamp indicates normal tape motion.  |

- F. FAST FORWARD Switch  
Places the machine in the FAST FORWARD mode. May be entered from the STOP (if ready), START or RECORD mode. The START or RECORD mode will automatically be cancelled. Audio is normally muted in FAST FORWARD; holding the FAST FORWARD button in will cause the audio to unmute. The machine will remain in the FAST FORWARD mode until another mode is selected or a stop tone is reached.
- G. FAST FORWARD Lamp  
Contained in the FAST FORWARD switch, this lamp indicates that the transport is in the FAST FORWARD mode. When entering the START mode, the lamp will remain lit until normal speed is achieved and the audio is unmuted.
- H. TERTIARY Record Switch  
(Recorders Only) Used to record a tertiary cue tone. This switch functions in the START as well as in the RECORD mode.
- I. TERTIARY Cue Lamp  
Contained in the tertiary record switch (Recorders Only) or on the front panel (Reproducers Only). Indicates the detection of a tertiary cue on the tape.
- J. SECONDARY Record Switch  
(Recorders Only) Used to record a Secondary cue tone. This switch functions in the START as well as in the RECORD mode.
- K. SECONDARY Cue Lamp  
Contained in the secondary record switch (Recorders Only) or on the front panel (Reproducers Only). Indicates the detection of a secondary cue on the tape,
- L. RECORD Switch  
(Recorders Only) This switch is used to place the machine into the RECORD/ready mode only when the transport is in the STOP/ready mode. Pushing the RECORD button twice when the transport is in the STOP/ready mode will defeat the automatic 1 kHz primary cue tone record function.
- M. RECORD Lamp  
(Recorders Only) Contained in the RECORD switch, this lamp indicates that the machine is ready to record (RECORD and STOP/ready lamp) or is recording (RECORD and START lamp).
- N. Left Input Level Control  
Used to adjust left channel record input level (Recorders Only).

- |                              |  |
|------------------------------|--|
| O. Right Input Level Control | Used to adjust right channel record input level (Recorders Only).  |
| P. AUDIO Indicator           | Indicates that the audio switcher is on (preamp unmuted). Illuminates when going from any mode to START. Extinguishes when leaving the START mode. In addition, the audio switcher may be turned off when starting another machine if the audio switcher interlock remote control terminals of all machine are wired together. See remote control pins 45 (Section 2.6.7). |
| Q. 1 kHz DEFEAT Indicator    | (Recorders Only) Indicates that the RECORD switch was pushed twice while the machine was in the STOP/ready mode, thus defeating automatic recording of the 1 kHz primary cue tone.   |
| R. Cleaning Switches         | Located in the front of the right cartridge edge guide. Screwdriver accessible from the cartridge slot. When switched on (up position) the start switch is enabled allowing the pressure roller to be cleaned from the front of the machine, and additional diagnostics to take place.   |

### 3.3 NORMAL OPERATION

#### 3.3.1 Recording

- A. Using an ESD10 Eraser/Splice Detector, bulk erase and find the splice of a cartridge to be recorded.
- B. Insert the cartridge into the recorder. The READY lamp will illuminate.
- C. Push the RECORD button. The RECORD lamp will illuminate.
- D. Preset record levels should correspond to an average reading of -1 to 0 on the VU meter(s) before the cartridge is started.
- E. When the level is set, recue the material to be recorded. Start the recorder, wait 1/4 second and start the material to be recorded. This delay allows for the pressure roller to engage the tape and initial flutter components to stabilize. A 1 kHz stop tone will automatically be recorded on the cue track at the beginning of the recording. The AUDIO indicator will illuminate.
- F. If desired, a Secondary cue tone can be recorded on the cue track at the end of the recorded material (See Section 3.3.4). If previously selected, the secondary cue can cancel RECORD, mute AUDIO, and place the machine in FAST FORWARD. The machine will stay in FAST FORWARD until the stop tone is reached. See Section 2.2.1.

- G. The record process may be terminated by pushing the STOP button, removing the cartridge (when the stop lamp is illuminated), pushing the FAST FORWARD switch, performing step F above (if applicable) or waiting for the cartridge to cue up automatically at the 1 kHz stop tone. The RECORD indicator will extinguish.

NOTE: Pressing the RECORD button twice before pushing the START button will defeat the automatic 1 kHz record function. The 1 KHZ DEFEAT indicator will illuminate.

### 3.3.2 Playback

- A. Insert a pre-recorded cartridge into the transport. The READY lamp will illuminate.
- B. Place the cartridge in motion by momentarily pressing the START button. The AUDIO indicator will illuminate.
- C. The cartridge will continue to run until a stop tone is sensed or the cartridge is stopped manually. In addition, the cartridge may be placed in the FAST FORWARD mode manually or automatically (if a secondary tone is sensed and a FAST FORWARD initiate jumper is installed). See Section 2.2.1. The AUDIO indicator will extinguish.
- D. The playback mode may be initiated from the FAST FORWARD mode. Audio will remain muted until normal speed is reached.

### 3.3.3 Fast Forward

- A. The FAST FORWARD mode may be initiated manually from the STOP mode (if the ready lamp is on), from the PLAY mode, or from the RECORD mode.
- B. The audio is muted in the FAST FORWARD mode but unmuting is possible by holding the FAST FORWARD button depressed.
- C. FAST FORWARD may be initiated automatically if a secondary tone is sensed and a FAST FORWARD initiate jumper is installed. See Section 2.2.1.
- D. The FAST FORWARD mode will continue until the cartridge is stopped manually, placed in the PLAY mode, or a 1 kHz stop tone is sensed. When going from the FAST FORWARD to the PLAY mode, the audio will remain muted until normal speed is reached.

### 3.3.4 Cue Tone Recording (Recorders Only)

- A. A secondary cue tone may be recorded when the machine is in the record or reproduce mode by pressing the SECONDARY button. The secondary tone will be recorded continuously while the button is depressed.
- B. Tertiary cue tones may be recorded when the machine is in the record or reproduce mode by pressing the TERTIARY button. The tertiary tone will be recorded continuously while the button is depressed.
- C. A 1 kHz stop tone is automatically recorded at the beginning of the recording process (unless manually defeated by pressing the RECORD button twice prior to starting the cartridge).
- D. Cue track logging recording (record machines only) may take place when the machine is in the record or reproduce mode. Connect the signal to be recorded to remote control pin 38. Ground remote control pin 37 to enable the cue track record bias, only when recording is taking place. The AUX CUE input control on the RECORD PWA is used to adjust the logging record level.

### 3.3.5 Playback with Audio Switcher Interlock

- A. If more than one machine deck is connected to one console input and it is desirable to have only one machine produce audio at one time, the audio switcher interlocks should be connected between machines. See Section 2.5.7 pin 45.
- B. In the multiple machine setup, any one of the machine decks can be started and be running simultaneously. Only the last machine started will pass audio. This will be the only machine with an illuminated AUDIO indicator.

NOTE: The audio switcher interlock feature is of great value if the operator inadvertently starts the wrong cartridge. The operator need only start the correct cartridge. The correct cartridge will be played while the incorrect cartridge continues to cue off the air.

### 3.3.6 Multiple Machine Audio Mixing

- A. Up to three machines may have their audio outputs connected in parallel without detrimental interaction between machines. This feature is often useful when more than one machine must feed a given console input.
- B. Audio output from a given machine will be reduced when additional machines are connected in parallel. Output level controls should be adjusted after parallel connections are made.
- C. When operating machines in parallel, remove any loading Resistors at the console input. It is advisable to operate the console in the bridging mode.

SECTION IV

## SECTION 4 MECHANICAL ADJUSTMENTS

### 4.1 PRESSURE ROLLER/MOTOR SHAFT ADJUSTMENT

The following adjustment is necessary if the motor has been removed. The adjustment should be checked anytime a new pressure roller is installed.

- A. Turn AC power switch and the cleaning switch on and start the machines.
- B. Place the tape guide, head alignment gauge (P/N 710-A0-001) near the pressure roller as shown. Check to see that the gauge is square with the roller. If not, stop the machine, loosen the motor mounting screws, gently move the motor, and retighten the motor screws. Start the machine and check roller alignment with the gauge. Repeat until the roller is square with the gauge. See figures below:

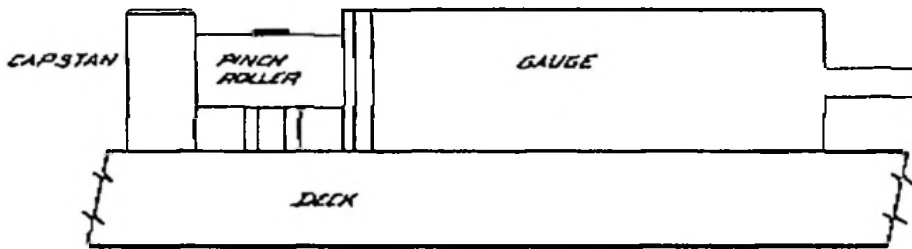

Motor in Correct Position  
Figure 5A

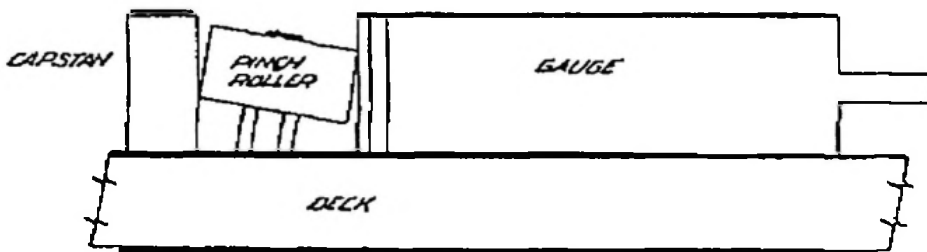

Move Motor Back  
Figure 5B

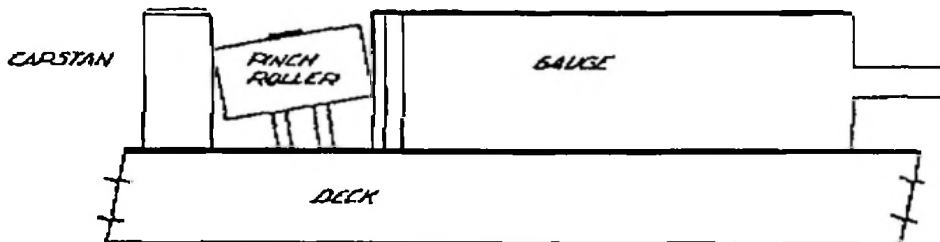

Move Motor Forward  
Figure 5C

- C. Carefully tighten the motor mounting screws using care not to change the motor position.

## 4.2 SOLENOID PLUNGER ADJUSTMENT

The following adjustments are necessary if the solenoid has been removed:

- A. Loosen the locking nut on the solenoid plunger and turn the cleaning switch to the on position. Turn the AC power switch on.
- B. Start the machine without a cartridge.
- C. If the solenoid does not bottom (no audible noise), stop the machine, and rotate the plunger 1/2 turn clockwise, if the solenoid hits bottom, go to step E.
- D. Repeat steps B and C until the solenoid bottoms.
- E. Stop the machine and rotate the plunger 1/4 turn counterclockwise.
- F. Start the machine.
- G. Repeat steps E and F until no audible noise is heard.
- H. Rotate the plunger an additional 1 1/2 turns counterclockwise when using the PRK-1 (black rubber) pinch roller or 3/4 turn counterclockwise when using the PRK-2 (clear polyurethane) pinch roller.
- I. Tighten the plunger locking nut and turn off the cleaning switch.

## 4.3 SOLENOID DAMPING ADJUSTMENT

The speed at which the solenoid engages and releases the pressure roller is determined by the air escape valve on the rear of the solenoid. The audible noise generated by the operation of the solenoid is proportional to the speed of the solenoid. The air escape valve may be adjusted by turning the screw at the rear of the solenoid. Turning the screw clockwise will restrict air flow and reduce audible solenoid noise.

## 4.4 CARTRIDGE GUIDANCE SYSTEM

Maximum system performance can only occur if the cartridge is consistently placed in the proper position each time it is inserted. There are three cartridge reference surfaces:

1. Deck Plate

The cartridge should lie flat on the deck plate. Downward pressure is applied along the left and right cartridge edge because the shell of the cartridge is the strongest along the left and right edges and the hold-down force serves to flatten, rather than warp the cartridge.



2. Head Bridge

When properly inserted, the front of the cartridge should seat squarely against the front of the head bridge. For this reason, tape guide screws, which vary widely and wear uneven indentations in the front of the cartridge in other manufacturers' designs, have been eliminated.

3. Right Cartridge Guide

When properly inserted, the cartridge should seat squarely against the right cartridge guide. Slight pressure along the left edge of the cartridge to hold it against the right cartridge guide is desirable.

While the deck plate point is fixed and not adjustable, the head bridge and the right cartridge guide interrelate and are adjusted together.

A. Refer to Figure 6 and scribe a cartridge as shown.

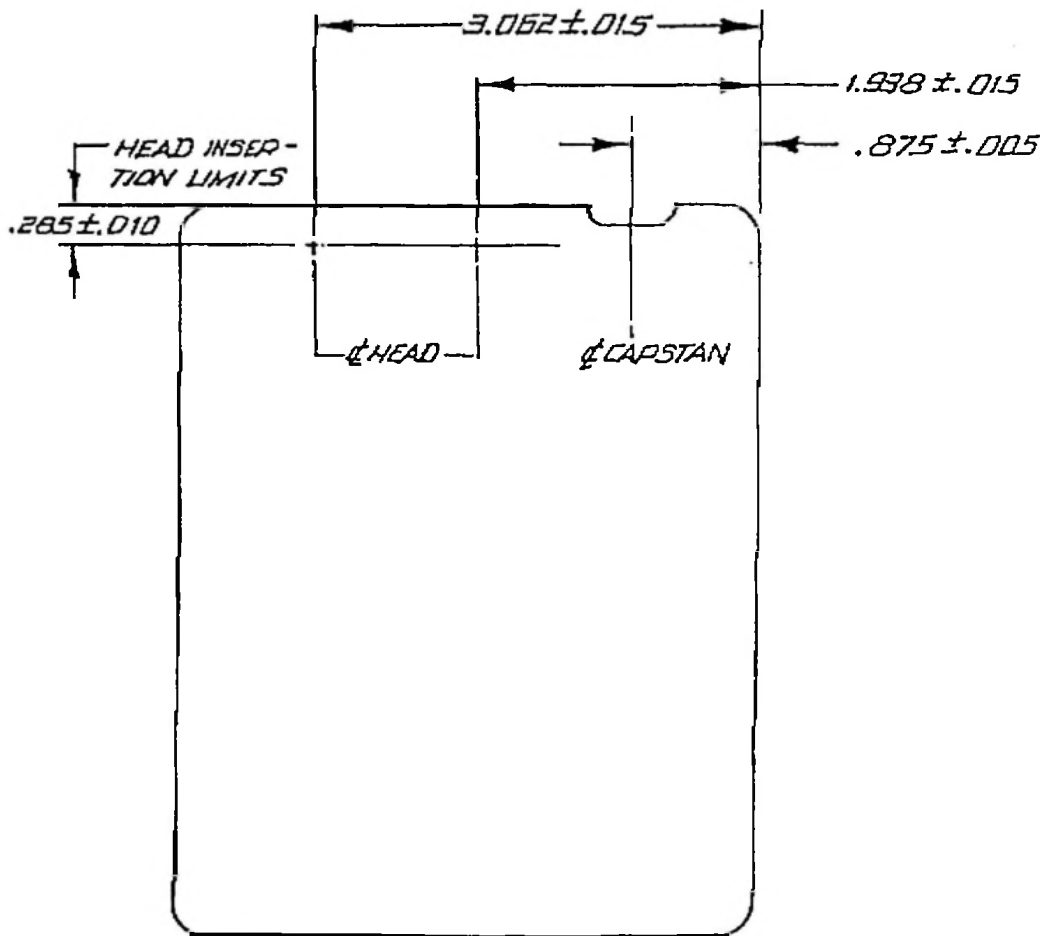

Figure 6

- B. Remove the head shield by loosening the retaining screws in the head bridge.
- C. Slowly insert the cartridge into the machine. If the scribed lines do not line up as shown, or if the cartridge does not seat squarely against the front of the head bridge and the right cartridge guide, realignment is necessary.
- D. Loosen (DO NOT REMOVE) the deck mounting screws on the right cartridge guide. Position the cartridge and right cartridge guide, while holding them tightly together, until the scribed capstan line is properly positioned. Be certain that the cartridge seats firmly and squarely against the front of the head bridge. Tighten the right cartridge guide screws while making certain that the cartridge guide does not move.
- E. As a final test, remove and re-insert the cartridge while holding the cartridge firmly against the right cartridge guide. The cartridge should seat squarely against the front of the head bridge and the scribed lines should be aligned above the center of the head bridge. The above alignment is extremely important for proper azimuth and stereo phase repeatability. Make certain that the cartridge position is adjusted as carefully as possible. When completed, re-install the head shield.

#### 4.5 HEAD BRIDGE ADJUSTMENTS

Head Bridge adjustment includes setting the tracking height, zenith and azimuth on each head, and the tape guide height on each guide (Figure 7).

##### 4.5.1 Tape Guide Alignment

Using the Tape Guide/Head Alignment gauge, align the tape guide by turning the tape guide adjustment screw so that the inside edge of the upper guide finger just contacts the top of the height gauge (See drawing 750-A0-440, Sheet 2). Repeat for the other guide(s). (Note: There are normally two Tape Guides on each unit. However, an optional Center Tape Guide is available.)

**NOTE:** Worn guides may seriously affect stereo performance. Guides should be checked periodically for signs of wear and replaced when necessary.

The Head Bridge includes alignment in four axes, Height, Azimuth, Zenith and Insertion.

Remove the machine's outer cover, permitting access to the Head Block.

**NEVER FORCE HEAD ALIGNMENT SCREWS!!**

##### 4.5.2 Insertion Adjustment

To adjust for insertion for most common cartridges, insert a Fidelipac® Model 328 Head Insertion Gauge cartridge into the machine.

Adjust the Tape Heads for equal penetration within the limits of the scribe marks on the cartridge cover as viewed from directly above.

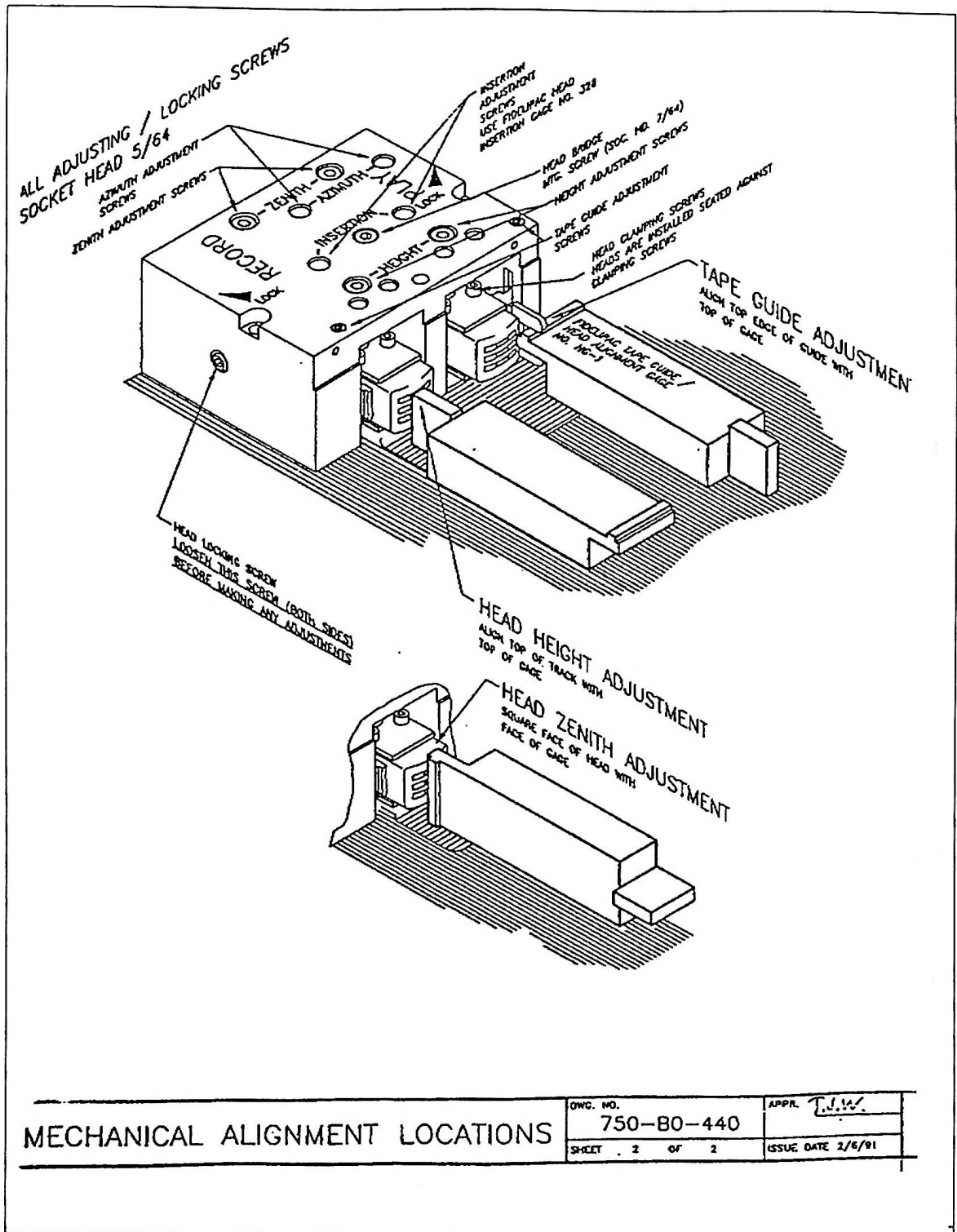

MECHANICAL ALIGNMENT LOCATIONS	OWC. NO.	APPR. <i>T.J.W.</i>
	750-80-440	
	SHEET 2 OF 2	ISSUE DATE 2/6/91

Figure 7

### 4.5.3 Height and Zenith Adjustment

1. Loosen the .050" Allen head locking screws on each side of the head block  $\frac{1}{4}$  turn.
2. Height and Zenith alignments should be performed with the machine turned off.
3. As shown in figure 7 (drawing 750-A0-440, Sheet 2), place a HG-1 Head Height & Zenith Gauge against the head to be aligned.
4. Using a Phillips screwdriver, adjust the Height alignment screw such that the top edge of the top track pole piece is aligned with the top of the HG-1.

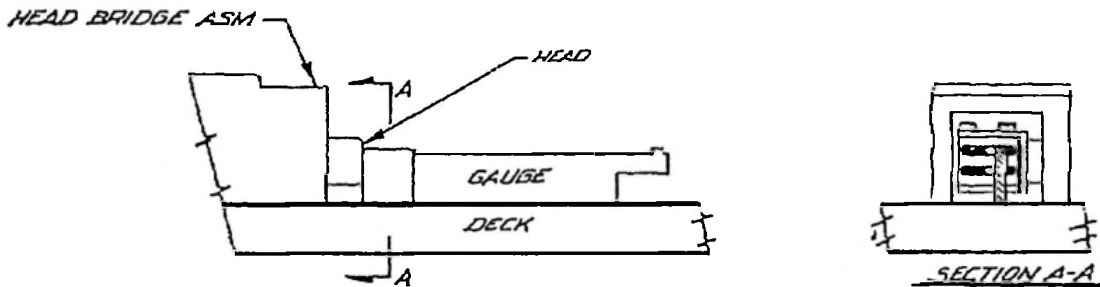

(Figure 8)

5. Using a Phillips screwdriver, adjust the Zenith alignment screw such that the vertical front surfaces of the head and HG-1 are parallel.
6. Recheck both Height and Zenith alignments.
7. Repeat the above procedure for the second head.
8. Retighten both head locking screws.

**BE SURE TO DEMAGNETIZE THE HEADS BEFORE USING THE MACHINE.**

NOTE: Head Height will be peaked during the electrical adjustment.

### 4.6 HEAD AZIMUTH ADJUSTMENT

Azimuth alignment is normally performed during reproduce and record alignments.

A 5/64" Allen head driver is required to adjust the Height alignment screws.

NOTE: Stereo Azimuth alignments are most easily accomplished using either a dual trace oscilloscope in the dual trace "chop" display, or a good quality phase meter.

#### 4.6.1 Monophonic Reproduce Head Azimuth

While playing the "Set Azimuth" portion of a standard Spot Frequency Alignment Cartridge, adjust the Play Azimuth for a peak signal at the audio output of the machine.

#### 4.6.2 Monophonic Record Head Azimuth (Recorder only)

Load a blank cartridge into the machine. Inject a 16 kHz signal at a nominal level into the audio input and enter the RECORD mode. Adjust the Record Azimuth for a peak signal at the audio output of the machine.

#### 4.6.3 Stereo Reproduce Head Azimuth

While playing the While playing set "Set Azimuth" portion of a standard Spot Frequency Alignment Cartridge, adjust the Play Azimuth for both peak and "in phase" signals at the audio outputs of the machine.

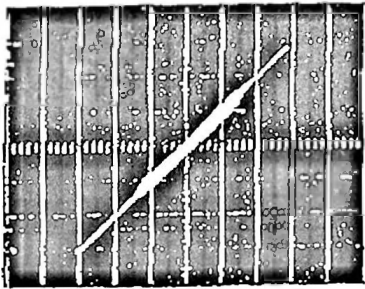

IN PHASE  
Figure 9A

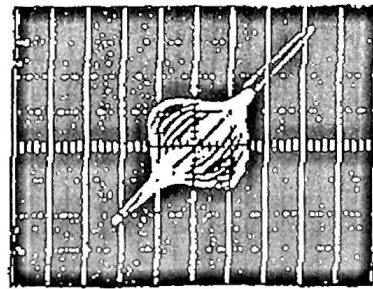

OUT OF PHASE  
Figure 9B

#### 4.6.4 Stereo Record Head Azimuth (Recorder only)

Load a blank cartridge into the machine. Inject a 16 kHz signal at nominal level into both audio inputs and enter the RECORD mode. Adjust the Record Azimuth for both peak and "in phase" signals at the audio outputs of the machine.

#### 4.6.5 Tape Head Replacement

The tape heads are clamped into the head bracket. To remove a tape head, loosen the clamping screws (See Figure 7), and gently pull the head forward. Use care not to bend the pins when removing the leads from the tape head.

When re-connecting the new head, be certain not to reverse polarity of any connections. Observe the color coding of the head cables: Left = Red; Right = Blue; Cue = Yellow. When installing a new head, insert it into the clamp as far as possible and tighten the clamp screws. The head height and azimuth should then be checked and aligned as necessary (See Section 4.5).



REC.TONE METER

PLAY CUE LOGIC

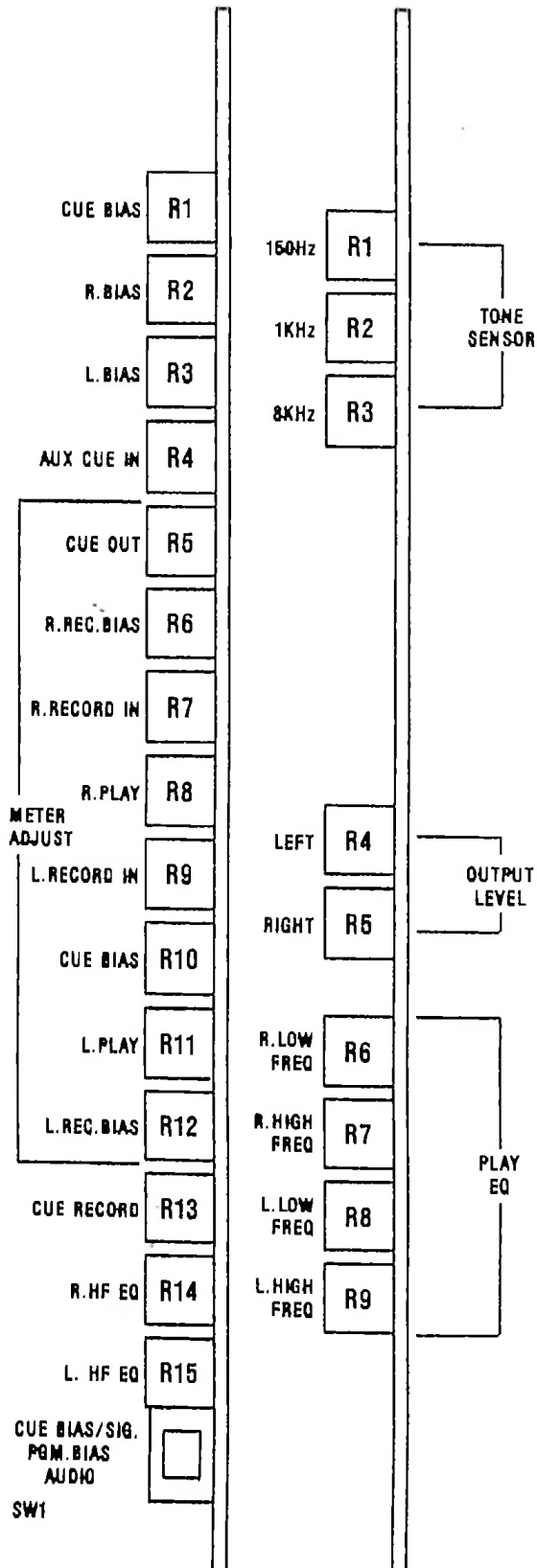

REC.TONE METER      PLAY CUE LOGIC

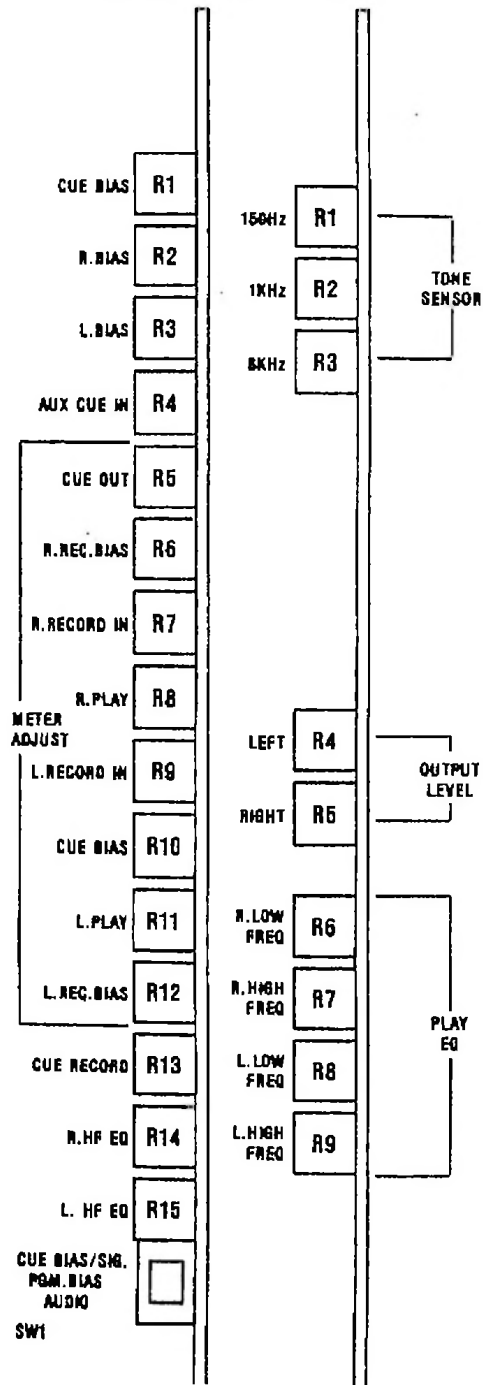



## SECTION 5 ELECTRONIC ADJUSTMENTS

Before making any electronic adjustments, please make certain that the mechanical adjustments discussed in Section 4 have been properly made. The cartridge and the machine work together as a system and the overall machine performance is dependent on proper mechanical alignment.

For proper operation, the following adjustments must be made in the order outlined below.

### 5.1 PROGRAM PLAYBACK ADJUSTMENTS

The following adjustments are located on each of the PLAY/CUE/LOGIC PWA. Figure 11 shows the location of the various adjustment pots.

#### 5.1.1 Playback Equalization

- A. Connect a 600 ohm load to both the left and right playback amplifier outputs. Connect a high impedance voltmeter across the left channel load.
- B. While reproducing an NAB Standard Spot Frequency Alignment Tape, note the level of the 1 kHz, -10 VU reference tone, as displayed on the external voltmeter.
- C. Adjust Low Frequency (LF) and High Frequency (HF) Playback Equalization trimmers (R8 & R9) for a reading equal to the reference tone at 50 Hz (LF) and 12.5 kHz (HF) respectively.
- D. For stereo machines, move the voltmeter to the right channel and repeat steps B and C using R6 & R7.

#### 5.1.2 Output Level

- A. Connect a 600 ohm load to both the left and right channel outputs. Connect a high impedance voltmeter across the left channel load.
- B. While reproducing a 1 kHz standard output level tape recorded at 160 nWb/m, set the Output trimmer (R4) for the desired level. If an output level less than -10 dBm is required, the reproducer output should be attenuated externally.
- C. For stereo machines, move the voltmeter to the right channel and repeat step B with R5.

**NOTE:** There is a 6 dB level difference between balanced and unbalanced output. If an unbalanced voltmeter is used, set the output level 6 dB below the desired balanced output.

## 5.2 CUE DETECTOR FREQUENCY CENTER

These are factory adjustments and will not normally need resetting.

- A. Remove the PLAY/CUE/LOGIC PWA and mount it on the extender PWA.
- B. Remove IC U12 from its socket.
- C. Connect a sine wave oscillator to remote control pin 39 and ground.
- D. Set the oscillator for 1 volt RMS and 1 kHz.
- E. Check that all sensitivity trimmers are set to approximately one half range.
- F. Monitor U1-1 with an oscilloscope and adjust R22 for maximum signal.
- G. If the signal on the oscilloscope appears clipped reduce the oscillator output and repeat step F.
- H. Set the oscillator to 3 kHz.
- I. Monitor U2-1 with an oscilloscope and adjust R29 for maximum signal.
- J. If the Signal on the oscilloscope appears clipped, reduce the oscillator output and repeat step I.
- K. Similarly, set the oscillator to 150 Hz, monitor U2-7 and adjust R33.
- L. Set the oscillator to 8 kHz, monitor U1-7 and adjust R27.
- M. Install IC U12 in its socket.

## 5.2 CUE DETECTOR SENSITIVITY

The sensitivity of the 150 Hz, 1 kHz and 8 kHz cue tone detectors may be individually adjusted. The adjustment trimmers are located on the PLAY/CUE/LOGIC PWA.

### 5.3.1 1 kHz Sensitivity

- A. Turn the 1 kHz trimmer (R2) fully counterclockwise.
- B. While reproducing a 1 kHz Cue Tone Test Tape recorded at -6 VU (80 nWb/m), slowly rotate the 1 kHz trimmer so that the sensor just triggers and stops the machine.

- NOTES:
1. When adjusting the 1 kHz control, wait 2 seconds after the cartridge starts. The sensor is disabled for this time.
  2. The above represents the threshold adjustment. NAB Standards specify that 1 kHz cue tones be recorded at 0 dB reference 160 nWb/m.

### 5.3.2 150 Hz Sensitivity

- A. Turn the 150 Hz trimmer (R1) fully counterclockwise.
- B. While reproducing a 150 Hz Cue Tone Test Tape recorded at 0 VU (160 nWb/m), slowly rotate the 150 Hz trimmer (R1) until the sensor just triggers and illuminates the front panel SECONDARY indicator.
- C. Connect a high impedance voltmeter or oscilloscope to pin 39 of the remote control. Record the level of the 150 Hz "0" VU tone for later use.

### 5.3.3 8 kHz Sensitivity

- A. Turn the 8 kHz trimmer (R3) fully counterclockwise.
- B. While reproducing an 8 kHz Cue Tone Test Tape recorded at -10 VU (50 nWb/m), slowly rotate the trimmer (R3) until the sensor just triggers and illuminates the front panel TERTIARY indicator.

## 5.4 PLAYBACK METER ADJUSTMENTS

- A. While reproducing a standard level 1 kHz test tape, adjust the Left Play Meter trimmer (R4) on the PWA for a 0 VU indication on the left front RECORD panel meter.
- B. Repeat for the right channel by adjusting the Right Play Meter trimmer (R5).

## 5.5 RECORD ADJUSTMENTS

The following adjustments are located on the RECORD PWA.

### 5.5.1 Bias Adjustments

- A. Connect a 600 ohm load to both left and right reproducer outputs. Connect a high impedance voltmeter across the left channel load.
- B. Connect an audio oscillator to both left and right record inputs.
- C. Select an erased cartridge of at least 3.5 minutes duration. This cartridge should be in good working order and representative of cartridges presently used by your facility.
- D. Insert the cartridge and press the RECORD button.

- E. Set the oscillator frequency to 10 kHz at -10 VU on the front panel VU meters.
- F. Start the machine and adjust the oscillator level for an indication on the external voltmeter that is 10 dB below the standard output level. See Section 5.1.2
- G. Slowly rotate the Bias trimmer (R3) on the RECORD PWA from minimum (fully counterclockwise) to maximum (fully clockwise) to find the maximum reading on the external meter. Set the Bias trimmer for a maximum reading on the external meter.
- H. For standard NAB cartridges, slowly rotate the Bias trimmer clockwise until the level indicated on the external voltmeter decreases by 2 dB (2 dB overbias). This is the correct bias setting for standard tapes. For HOT, HOLN or Cobalt tapes, use 3 dB overbias.
- I. For stereo machines, move the voltmeter to the right channel and repeat steps C through H, using R2.

### 5.5.2 Record Level

- A. Connect a 600 ohm load to both left and right reproducer outputs. Connect a high impedance voltmeter across the left channel load.
- B. Connect an audio oscillator to both left and right record inputs.
- C. Select an erased cartridge of at least 3.5 minutes duration. This cartridge should be in good working order and representative of cartridges used presently by your facility.
- D. Insert the cartridge and press the RECORD button.
- E. Set the test oscillator frequency to 1 kHz and adjust the oscillator level for an indication of -10 VU on the front panel VU meter.
- F. Start the cartridge and adjust the Input Level potentiometer (located on the front panel) for an indication on the external voltmeter that is 10 dB below the standard reference level. See Section 6.1.2.
- G. For stereo machines, move the voltmeter to the right channel and repeat steps C through F.

### 5.5.3 Record Equalization

- A. Change oscillator frequency to 12.5 kHz and adjust the High Frequency Equalization trimmer on the RECORD PWA (R15) for a 12.5 kHz level equal to the 1 kHz level as indicated on the external voltmeter.
- B. Set the oscillator to 50 Hz and slowly increase the frequency to 16 kHz. The level indicated on the external voltmeter should be equal to the 1 kHz level, plus or minus 2 dB throughout the frequency range. If insufficient control range is encountered, a bias adjustment may be necessary.
- C. For stereo machines, move the voltmeter to the right channel and repeat steps A and B, using R14.

## 5.6 PROGRAM RECORD METER CALIBRATION

### 5.6.1 Bias Meter Calibration

- A. Turn the cleaning switch on.
- B. Set SW1 on the RECORD PWA to the PROGRAM BIAS position.
- C. Press the RECORD button and start the machine.
- D. Adjust the Left Record Bias Meter trimmer on the RECORD PWA (R12) for a 0 VU indication on the left front panel VU meter.
- E. Adjust the Right Record Bias Meter trimmer (R6) for a 0 VU indication on the right front panel VU meter.
- F. Turn the cleaning switch off. Set SW1 to the AUDIO mode.

### 5.6.2 Record Level Meter Calibration

- A. Set SW1 on the RECORD PWA to the AUDIO position.
- B. Connect an audio oscillator to both left and right recording inputs.
- C. Select an erased cartridge of at least 3.5 minutes duration. This cartridge should be in good working order and representative of cartridges used presently by your facility.
- D. Insert the cartridge and press the RECORD button.
- E. Start the machine and adjust the oscillator level for an indication on the external voltmeter that is equal to the standard reference level. Stop the machine.

- F. Press the RECORD button, and adjust the Left and Right Input Meter trimmers (R9, R7) on the RECORD PWA for a 0 VU reading on the front panel VU meter.
- G. Turn the cleaning switch off, Set SW1 to the AUDIO positions.

## 5.7 CUE BIAS ADJUSTMENT

- A. Connect a high impedance voltmeter to remote control pin 39.
- B. Insert an erased cartridge into the machine,
- C. Start the cartridge, press and hold the TERTIARY record switch and adjust the Cue Bias trimmer on the RECORD PWA (R1) for a maximum signal as displayed on the voltmeter.
- D. Slowly rotate the Cue Bias trimmer clockwise until the level indicated on the external voltmeter decreases by 2 dB (2 dB overbias).

## 5.8 CUE RECORD LEVEL

- A. Connect a high impedance voltmeter to remote control pin 39.
- B. Insert an erased cartridge into the machine.
- C. Start the cartridge, press and hold the SECONDARY button and adjust the Cue Record trimmer on the RECORD PWA (R13) for a level indication 6 dB greater than the level recorded in Section 5.3.2.

## 5.9 CUE METERING

- A. Set SW1 on the RECORD PWA to CUE BIAS/SIGNAL.
- B. Insert an erased cartridge into the machine.
- C. Start the cartridge, press and hold the SECONDARY button and adjust the Cue Bias Meter trimmer on the RECORD PWA (R10) for a 0 VU reading on the left front panel VU meter. Adjust the Cue Out Meter trimmer on the RECORD PWA for +3 VU reading on the right front panel VU meter.



## SECTION 6 CIRCUIT DESCRIPTION

### 6.1 RECORD PWA

#### 6.1.1 Brief Description

The RECORD PWA performs the following functions:

- A. Left & Right Channel input, equalization, and record head driver circuits.
- B. 1 kHz, 150 Hz, 8 kHz and 120 kHz oscillators.
- C. Cue record head driver.
- D. Meter control logic, meter amplifier and meter function switch.
- E. Record logic.

#### 6.1.2 Detailed Description

Op-Amp U12A is configured as a differential input amplifier for the left channel while U12B performs the same function for the right channel. The signal is then routed to the front panel record level controls.

The left channel level adjusted signal is then routed to U17A which provides high frequency equalization. The amount of high frequency boost is adjusted by R15. Capacitor C6 is normally supplied shorted out by W2. When W2 is removed, the equalizer will introduce a 3 dB boost at 50 Hz in accordance with the 1964 NAB Equalization Standard.

The equalized signal is summed with the 120 kHz bias signal (as adjusted by R3) and is routed to FET Q8. FET Q8 conducts the combined signal to U17B in the Record/Start mode. U17B is the record head amplifier and driver. This circuit insures constant current operation by placing the record head within the feedback loop. Record head current is sampled across R107 and is fed back to the inverting input.

U10, U11, U13 and U9 are FET stabilized Wien bridge oscillators at 150 Hz, 1 kHz, 8 kHz, and 120 kHz respectively. Since all four oscillators operate the same way, only the 1 kHz oscillator will be discussed.

U11A is the oscillating stage with R51, C28 and R68, C29 forming the positive feedback path and determining the operating frequency. R50, R49 and FET Q3 form the negative feedback loop. FET Q3 is used to stabilize the oscillator output amplitude. The oscillator output is rectified by D15 and filtered by integrator U11B. Resistors R73 and R69 set the output amplitude.



The 150 Hz, 1 kHz and 8 kHz signals are routed to U14, a 4066 quad analog gate. U14 receives control signals from U5A or U5B to turn on the 150 Hz or 8 kHz gate. U6B, a 4528 monostable, controls the 1 kHz gate. The length of the 1 kHz cue tone is set by R90 and C50. U5F inhibits cue tone recording when the machine is not in the Start or Record/Start mode.

The selected cue tone(s) are summed at U15A. Trimmer R13 adjusts the cue record level. When a cue tone is recorded, or if the remote cue bias is selected, FET Q9 will conduct and bias will be summed with the cue signal at the cue record head driver U15B.

U6A outputs a pulse when the Record button is pushed. This pulse triggers "D" flip-flop U7A and places the machine into the record mode. If the record switch is pushed again, U6A will generate another pulse and trigger U7B placing the machine in the 1 kHz defeat mode. This mode inhibits U6B from recording a 1 kHz cue tone.

U4 is a dual 4 input analog gate. Signals to be metered are applied to the inputs of U4. Logic signals from SW1 & U8B instruct U4 to output the desired signal to amplifier U3. The signal from U3 is rectified and filtered by U1 and is then sent to the front panel LED bar graph controller IC. The time constants of the rectifier and integrator conform to VU standards.

## 6.2 PLAY/CUE/LOGIC PWA

### 6.2.1 Brief Description

The PLAY/CUE/LOGIC PWA performs the following functions:

- A. Reproduce equalized preamplifiers, Audio Muting, and Audio Output amplifiers.
- B. Cue equalized preamplifier; 150 Hz, 1 kHz, 3 kHz, 8 kHz active filters and detectors; 150 Hz and 8 kHz relays.
- C. Logic control of the following functions: Start, Stop, Fast Forward, Solenoid Control, Audio Switching and Muting.

### 6.2.2 Detailed Description

Only the left channel will be discussed, as the right channel is identical. The left channel reproduce head is connected to the PWA at terminals FF and 28. Tape head loading is provided by R71 (tape head resonance capacitors are located on the MOTHER PWA). Amplifier U13A is utilized as a low noise equalized preamplifier. The setting of R8 in conjunction with C9 determines the low frequency equalization breakpoint and the setting of R9 in conjunction with C9 determines the high frequency equalization breakpoint. The overall gain is set by R69.

The preamp output is routed through R4 - the output level control - to FET Q19 which provides audio muting.

U7A provides final amplification and audio output drive. U7B is a unity gain inverter providing only audio output drive. The output from U7B is identical to U7A in amplitude but 180° out of phase. The overall gain of the output stage is set by R41 and R16. Resistors R64 and R44 allow the direct paralleling of up to 3 cartridge machines. T1, C37 and C38 provide output RF protection.

The cue channel reproduce head is connected to the PWA at terminals CC and 25. Tape head loading is provided by R60 (tape head resonance capacitors are located on the MOTHER PWA). U12A provides amplification and equalization for the cue track. C32, R59 and R58 provide NAB equalization, while R57 sets the overall gain. U12B provides additional gain as set by R55 and R56. The audio is routed to cue detector level controls R2, R3 and R1. R2 sets the threshold of the 1 kHz and 3 kHz cue detectors. R3 and R1 set the threshold of the 8 kHz and 150 Hz detectors, respectively. Cue audio is routed to U1A, the 1 kHz active filter. (Resistor R22 sets the center frequency of the 1 kHz filter.)

Resistors R29, R27 and R33 set the center frequency of the 3 kHz, 8 kHz and 150 Hz active filters. (D1-D4 and C1-C4 rectify and filter the output of the active filters.) Diodes D18, D19, D36 and D37 inhibit the 150 Hz and 8 kHz detectors while the machine is in the STOP or FAST FORWARD mode. (FET Q17 shunts the output of the 1 kHz sensor when the machine is in FAST FORWARD and FET Q4 shunts the output of the 3 kHz sensor when the machine is not in FAST FORWARD.) U8 provides level detection. U10-10 goes low when a stop tone is detected. FET Q7, RN8 (pins 5 and 6), and C30 inhibit the stop detector when the cartridge is first put in motion. Transistors Q5 and Q6 drive the front panel cue LEDs in addition to the cue relays, which provide a normally open closure at the remote control.

IC U9 contains 4 R-S type flip-flops. The flip-flops and input/output pins are:

	SET	RESET	OUTPUT
START	3	4	13
FAST FORWARD	7	6	9
AUDIO SWITCHER	11	12	10
LAMP FLASH	15	14	1

When the set input is momentarily pulled low, the output will go high; pulling the reset low will cause the output to return to a low state. U5 (74C42 BCD-to-decimal decoder) allows only the first transport switch pushed (Start, Stop or Fast Forward) to reach U9. When a U5 input (15, 14, 13) goes high, its respective output (2, 3, 4) will go low. U3A and U3B decode the active low commands and reset the Start or Fast Forward flip-flop when a different transport function is selected.

U6-12 is high when the machine is in the STOP mode (U9-9 and U9-13 low). If a cartridge is in place (edge connector pin 15 high), U10-3 will be high which turns on Q12 (remote ready) and enables RECORD switch signals to pass through U3D and reach the RECORD PWA. In addition, when U10-3 is high the signal appearing at U10-6 passes through U10B and turns on the STOP lamp. The signal at U10-6 is controlled by the lamp flash flip-flop. When the transport leaves the STOP mode (U6-12 low), the flash flip-flop is reset (U9-1 low). With U9-1 low, flash pulses pass through D32 to U10-6. When the transport is placed in the STOP mode, U10-5 goes high and the STOP lamp will flash. Removing a cartridge will set the flash flip-flop U9-1 high and, when a cartridge is re-inserted, the STOP lamp will illuminate without flashing.

The audio switcher allows multiple machines to be paralleled to one console input, and with one additional connection between audio switcher interlocks, only the last machine started will pass audio while the balance of the machines will be muted. When a machine is started, the audio switcher flip-flop is set. U9-10 goes high turning on Q13 and the related front panel audio LED. When Q13 turns on, transistors Q1 and Q2 send a short pulse to the audio switcher interlock, which resets the audio switcher flip-flops, and mutes the audio of any interconnected machines. The reset pulse does not reset the local audio switcher since the reset pulse is much shorter than the set pulse, which is determined by the length of time that the START button is depressed. The audio will unmute whenever the gates of Q19 and Q20 are pulled low. When the machine is started, U9-10 goes high turning on Q18 and the audio will unmute.

When transferring from FAST FORWARD (U9-9 high and Q8 turned on), Q8 prevents the audio from unmuting before the motor slows down. In addition, when the FAST FORWARD button is depressed and held, U5-5 will remain low allowing C33 to discharge and unmute the audio.

The solenoid is controlled by Q14 and Q15. When the solenoid is energized, U10-11 goes high turning on Q15, which pulls the solenoid "-" to -18V. U6-8 momentarily goes low (when U10-11 first goes high) as controlled by C23 and R35 turning on Q14 which pulls the solenoid "+" to the +RAW DC supply. When C23 charges fully, U6-8 will return high turning off Q14. The solenoid "+" is now pulled to ground through D33. In summary, the solenoid is momentarily powered from the +RAW DC and the -18V supply, which provides a fast start. The solenoid is then held by the -18V supply.

User selected jumper option W1 (position B) works in conjunction with the flash flip-flop to inhibit the START switch if the STOP lamp is flashing (U9-1 and U3-9 low) which prevents double plays.

Jumpers W2 and W3 are used in conjunction with the 150 Hz detector to mute the audio (W2) and initiate FAST FORWARD (W3). Jumper position "A" initiates the desired function at the beginning of the 150 Hz tone while position "B" waits until the end of the 150 Hz tone.

## 6.3 MOTHERBOARD PWA

### 6.3.1 Brief Description

The MOTHERBOARD PWA provides the following functions:

- A. Interconnection between PWAs.
- B. Power supply and voltage regulators.
- C. Solenoid and motor power connections.
- D. Connection between tape heads, PLAY and RECORD PWAs.

### 6.3.2 Detailed Description

AC power from the rear panel is connected to the power transformer at P1. The power transformer, which features dual primaries and dual secondaries, is connected at P2. The transformer primary connections to P2 differ depending on the local line voltage (110V or 220V).

One secondary is utilized in a center-tapped bi-polar full wave bridge configuration. Diodes ~~D3-D6~~ <sup>D1-D4</sup> rectify the AC and capacitors ~~C1~~ and ~~C2~~ provide filtering. Three terminal regulators VR1-VR3 are used to provide +15 and -15 operating voltages. In addition, the +RAW DC is used in energizing the solenoid.

The DC motor is connected to P3 on the MOTHERBOARD PWA.

The motor is driven under servo control (FAST FORWARD is three times normal speed).

U2 provides +7.5 volts and -7.5 volts to the PLAY/CUE/LOGIC and RECORD PWAs.

U1 and related components divide the AC primary and supply the lamp flash signal to the PLAY/CUE/LOGIC PWAs.

## 6.4 FRONT PANEL VU PWA (Recorders Only)

### 6.4.1 Brief Description

The VU PWA performs the following functions:

- A. VU meter display
- B. Audio & 1 kHz defeat LEDs
- C. Record level controls

### 6.4.2 Detailed Description

The VU Meters consist of a 10 segment (7 Green, 3 Red) LED bar graph and a LM3916 VU meter display driver. The signal to be metered is selected and rectified on the RECORD PWA and then routed to transistor Q2.

Transistor Q2 level-shifts the signal to be displayed before it is sent to the input of the LM3916s (U1-5). The LM3916 compares the input level with the predetermined full-scale level (as set by R3 and R4) and illuminates the proper LED segments.

SECTION VII

## SECTION 7 MAINTENANCE

Advanced technology incorporated into the design of the CTR10 series such as modular electronics, permanently lubricated solenoid plunger, capstan motor bearings, self-aligning pressure roller, and solid state optical sensing and VU meters permit operation of the tape machine with a minimum of maintenance.

Most of the maintenance which is required consists of routine cleaning, degaussing heads and routine alignment checks.

The frequency of maintenance is dependent upon a number of factors; i.e., type and condition of tape used, duty cycle of operation, overall frequency of use, and general ambient conditions. Therefore, the following list contains suggested service intervals for typical maintenance operations. Actual service intervals should be determined by the user.

### 7.1 NORMAL PREVENTIVE MAINTENANCE - CHECKS AND ADJUSTMENTS

#### 7.1.1 As Required

Clean heads, pressure rollers, capstan and tape guides using only Isopropyl Alcohol or a freon cleaner such as Miller-Stephenson Freon TF. Use of other cleaning fluids may damage the heads.

#### 7.1.2 Monthly

- A. Degauss heads.
- B. Check solenoid linkage for proper operation and verify solenoid adjustment lock nut is tight.
- C. Check tape heads, guides and pressure roller for wear; adjust or replace as necessary.
- D. Check head alignment.

#### 7.1.3 Every Six Months

- A. Overall cleaning.
- B. Check motor speed and flutter.
- C. Check playback levels and equalizations.
- D. Check record bias levels.

- E. Check program audio record levels and equalizations.
- F. Check cue tone sensor levels.
- G. Check cue bias level.
- H. Check cue record level.
- I. Check meter calibrations.

## 7.2 NORMAL PREVENTIVE MAINTENANCE - TOOLS AND TEST EQUIPMENT NEEDED

### 7.2.1 Tools

- A. 5/64 Allen hex wrench for head adjustments.
- B. 3/32 Allen hex wrench for head locks.
- C. 3/8 open end wrenches for solenoid adjustments.
- D. Electrical shop tools.

### 7.2.2 Test Equipment for Routine Alignment

- A. Voltmeter
- B. Oscilloscope
- C. Wow and Flutter Meter

## 7.3 TEST TAPES AND ALIGNMENT GAUGES

CartGuys and Fidelipac® supply test and calibration tapes and alignment tools and gauges for use with the CTR10, including those mentioned in the text. Consult the CartGuys catalog for available items.



HEAD BRIDGE ASSEMBLY      827-C0-401

DESCRIPTION	QTY	DESIGNATOR	PART NUMBER
BEARING BLOCK	2	M3	501-A0-400
HEAD LOCKING BLOCK	2	M7	501-A0-402
HEAD SHAFT	2	M4	502-B0-400
HEAD BRIDGE	1	M1	512-C0-400
HEIGHT ZENITH BEAM	2	M2	570-A0-400
HEAD CLAMP	2	M5	570-B0-401
THRUST PLATE	2	M6	570-B0-402
AZIMUTH BEAM	2	M9	571-B0-405
TAPE GUIDE CURVED	1	M21	5AB-A0-001
TAPE GUIDE STRAIGHT	1	M20	5AB-A0-002
BALL 3/16	2	M8	5B6-A0-400
SPRING COMP .1480 X 1/4	2	M22	5E2-04-148
SPRING, ZENITH BEAM	4	M10	5E2-A0-400
SPRING, AZIMUTH	2	M11	5E2-A0-401
SPRING, PENETRATION	2	M12	5E2-A0-402
FLAT WASHER SS .187 OD	2	M19	605-00-231
SCREW FL PHIL 4-40 X 1/4 SS	4	M17	645-A0-440
SCREW, 4-40X1/2 1820 FHP BLK	4	M14	64H-08-440
SCREW, 4-40X3/8 PBH STL	4	M15	681-06-440
SCREW, 4-40X5/16 SHS BLK	2	M18	6G2-05-440
SCREW SH 4-40X3/8 BL	2	M23	6Y2-06-440
SCREW SOC H.C. 2-56 X 1 BLK	4	M13	6Y2-10-256
SCREW SOC H.C. 2-56 X 5/8 BLK	4	M16	6Y2-0A-256
# 4 FLAT WASHER, STEEL PLATE	4	M24	601-00-400

ALL ADJUSTING / LOCKING SCREWS  
 SOCKET HEAD 5/64

AZIMUTH ADJUSTMENT  
 SCREWS  
 ZENITH ADJUSTMENT  
 SCREWS

INSERTION  
 ADJUSTMENT  
 SCREWS  
 USE FIDELIPAC HEAD  
 INSERTION GAGE NO. 328

HEAD BRIDGE  
 MTG. SCREW (SOC. NO. 7/64)  
 HEIGHT ADJUSTMENT  
 SCREWS

TAPE GUIDE ADJUSTMENT  
 SCREWS

HEAD CLAMPING SCREWS  
 HEADS ARE INSTALLED SEATED AGAINST  
 CLAMPING SCREWS

TAPE GUIDE ADJUSTMENT  
 ALIGN TOP EDGE OF GUIDE WITH  
 TOP OF GAGE

HEAD LOCKING SCREW  
 LOOSEN THIS SCREW (BOTH SIDES)  
 BEFORE MAKING ANY ADJUSTMENTS

HEAD HEIGHT ADJUSTMENT  
 ALIGN TOP OF TRACK WITH  
 TOP OF GAGE

HEAD ZENITH ADJUSTMENT  
 SQUARE FACE OF HEAD WITH  
 FACE OF GAGE

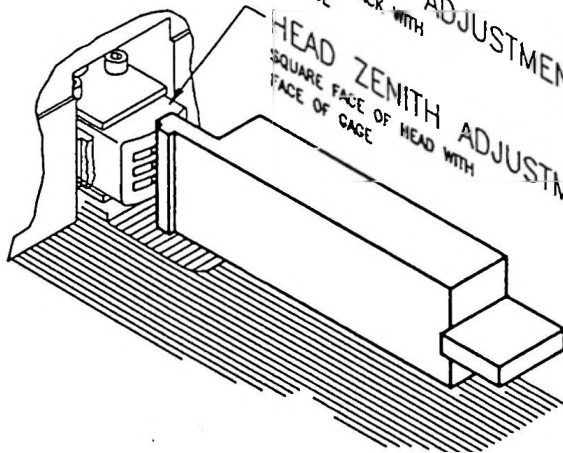
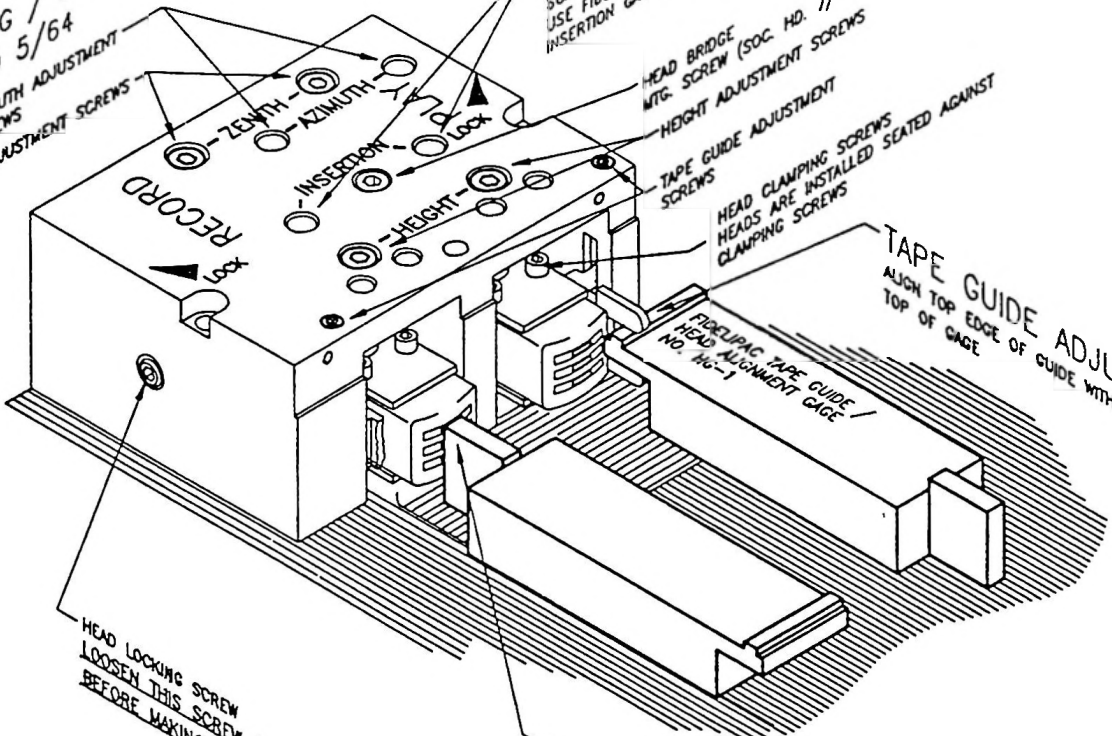

MECHANICAL ALIGNMENT LOCATIONS

OWG. NO. 750-B0-440	APPR. <i>T.J.W.</i>
SHEET 2 OF 2	ISSUE DATE 2/6/91

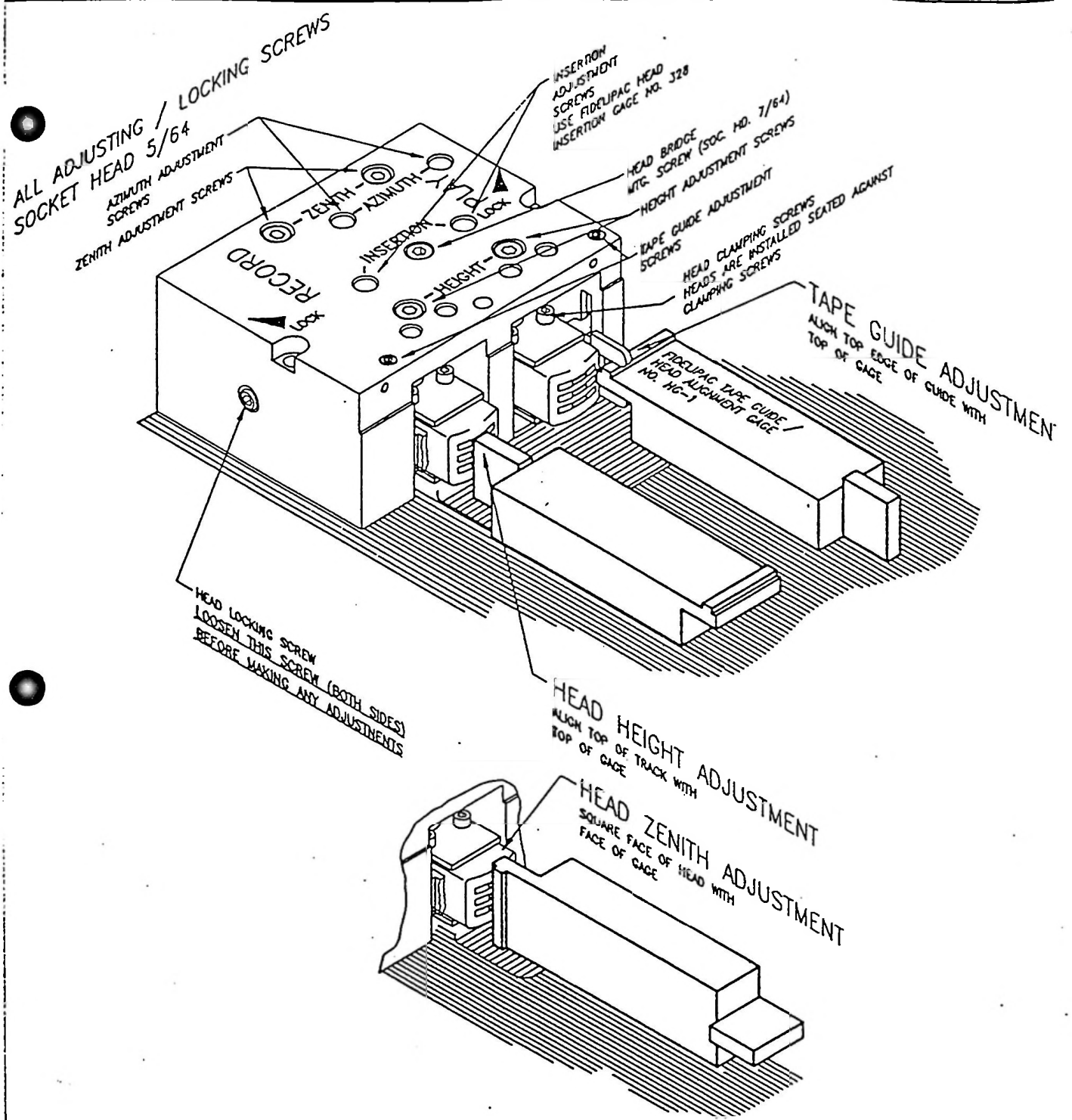

MECHANICAL ALIGNMENT LOCATIONS

DWG. NO. 750-80-440	APPR. <i>T.J.W.</i>
SHEET 2 OF 2	ISSUE DATE 2/6/91

## TAPE GUIDE ALIGNMENT

Using the Tape Guide/Head Alignment gauge, align the tape guides by turning the tape guide adjustment screw so that the inside edge of the upper guide finger just contacts the top of the height gauge (see drawing 750-A0-440 sheet 2). Repeat for the other guide(s). Note: there are normally 2 Tape Guides on each unit, however, an optional Center Tape Guide is available.

**NOTE:** Worn guides may seriously affect stereo phase performance. Guides should be checked periodically for signs of wear and replaced when necessary.

## HEAD ALIGNMENT

The Head Bridge includes alignment in four axes: Height, Azimuth, Zenith, and Insertion.

Remove the machine's outer cover, permitting access to the Head Block.

**NEVER FORCE HEAD ALIGNMENT  
SCREWS**

## INSERTION

To adjust Insertion for most common cartridges, insert a Fidelipac Model 328 Head Insertion Gauge cartridge into the machine.

Adjust Tape Heads for equal penetration within limits of scribe marks on cartridge cover as viewed from directly above.

## HEIGHT & ZENITH

Loosen the .050" Allen head locking screws on each side of the head block 1/4 turn.

Height and Zenith alignments should be performed with the machine turned off.

As shown in drawing 750-A0-440 sheet 2, place a HG-1 Head Height & Zenith Gauge against the head to be aligned.

Using a Phillips screwdriver, adjust the Height alignment screw such that the top edge of the top track pole piece is aligned with the top of the HG-1.

Using a Phillips screwdriver, adjust the Zenith alignment screw such that the vertical front surfaces of the head and HG-1 are parallel.

Recheck both Height and Zenith alignments.

Repeat the above procedure for the second head.

Retighten both head locking screws.

**BE SURE TO DEMAGNETIZE THE  
HEADS BEFORE USING THE MACHINE.**

**NOTE:** Head Height will be peaked during electronic adjustment.

## AZIMUTH

Azimuth alignment is normally performed during reproduce and record alignments.

A 5/64" Allen head driver is required to adjust the Height alignment screws.

**NOTE:** Stereo Azimuth alignments are most easily accomplished using either a dual trace oscilloscope in the dual trace "chop" display mode, or a good quality phase meter.

## MONO REPRODUCE AZIMUTH

While playing the "Set Azimuth" portion of a standard Spot Frequency Alignment Cartridge, adjust Play Azimuth for a peak signal at the audio output of the machine.

## MONO RECORD AZIMUTH [Recorder Only]

Load a blank cartridge into the machine. Inject a 16 kHz signal at nominal level into the audio input and enter Record mode. Adjust Record Azimuth for a peak signal at the audio output of the machine.

## STEREO REPRODUCE AZIMUTH

While playing the "Set Azimuth" portion of a standard Spot Frequency Alignment Cartridge, adjust Play Azimuth for both peak and in phase signals at the audio outputs of the machine.

## STEREO RECORD AZIMUTH [Recorder Only]

Load a blank cartridge into the machine. Inject a 16 kHz signal at nominal level into both audio inputs and enter Record mode. Adjust Record Azimuth for both peak and in phase signals at the audio outputs of the machine.

SECTION VIII

## SECTION 8 TROUBLESHOOTING

Some common types of operational problems, and solutions, are posted on the CartGuys web site: [www.CartGuys.com](http://www.CartGuys.com)

For further assistance, feel free to email us at [support@cartguys.com](mailto:support@cartguys.com), including as much detail as you can provide. We endeavor to respond promptly to all email.

You may also contact the factory, 520-327-4466. As we are located in the Mountain Time Zone, you may reach our voice mail system. However, again, we endeavor to respond as quickly as possible, so it may be useful to leave an email address, if possible, so we can respond outside of business hours.

Finally, we do provide a factory repair and refurbishing service at modest rates. Please contact us for the current shipping address and an RA number.

SECTION IX

## SECTION 9 DRAWINGS, SCHEMATICS, and PARTS LISTS

### NOTE:

Probably the most important items you will need to know about for spare parts and maintenance issues are these following items. For other needs, we encourage you to call us at 520-327-4466, or email us, so that we can ensure you get the right part number for your machine.

1. PRESSURE ROLLER KIT            PRK-2  
    This kit contains the pressure roller and all necessary washers.
  
2. HEADS  
    PLAY HEADS  
        MONO                    340-A0-000  
        STEREO                340-A0-002  
    RECORD HEADS  
        MONO                    340-A0-001  
        STEREO                340-A0-003
  
3. TAPE GUIDES  
    CURVED                    5AB-A0-001  
    STRAIGHT                5AB-A0-002
  
4. FRONT PANEL SWITCHES        364-A0-005
  
5. FRONT PANEL LENS  
    Red                        364-A0-007  
    Green                      364-A0-008  
    White                      364-A0-009  
    Yellow                     364-A0-010
  
6. Alignment aids  
    Cart Insertion Tape        328  
    Head Alignment Tool (HG-1) 710-A0-001 (or similar)  
    Right Angle Gauge        387  
    Audio Test tape            MRL-1  
    Wow & Flutter Test tape    452  
    Sweep Tone Test tape      455



PACKING LIST FOR CTR10 SERIES REPRODUCER MACHINES (11 or 13)

INDENTED BILL OF MATERIALS FOR PARENT ITEM NUMBER 867-A0-002

PART NUMBER	DESCRIPTION	QTY	SEQ
720-A0-000	SHIPPING CARTON A	1	1
730-A0-015	INSTRUCTION MANUAL CTR 10	1	2
727-A0-000	END CAP A EPS	2	3
427-A0-001	POWER CORD	1	4
417-A0-001	CONNECTOR PLUG 9 PIN D MALE	1	5
416-A0-000	CONNECTOR HOOD 9 PIN D	1	7
416-A0-002	CONNECTOR HOOD 50 PIN	1	8
582-A0-007	IDENTIFICATION LABEL	1	9
417-A0-002	PLUG 50 PIN D	1	20

PACKING LIST FOR CTR10 SERIES RECORD MACHINES (12 or 14)

INDENTED BILL OF MATERIALS FOR PARENT ITEM NUMBER 867-A0-003

PART NUMBER	DESCRIPTION	QTY	SEQ
720-A0-000	SHIPPING CARTON A	1	1
730-A0-015	INSTRUCTION MANUAL CTR 10	1	2
727-A0-000	END CAP A EPS	2	3
427-A0-001	POWER CORD	1	4
417-A0-001	CONNECTOR PLUG 9 PIN D MALE	1	5
417-A0-002	PLUG 50 PIN D	1	6
416-A0-000	CONNECTOR HOOD 9 PIN D	2	7
416-A0-002	CONNECTOR HOOD 50 PIN	1	8
582-A0-007	IDENTIFICATION LABEL	1	9
418-A0-005	CONNECTOR PLUG 9 PIN D FEMALE	1	10

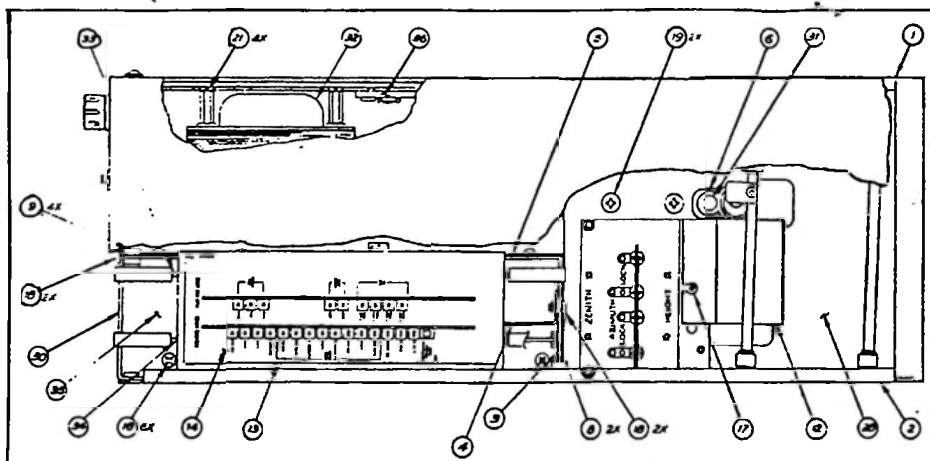

NOTES:  
 1 FOR CABLE CONNECTIONS OF THE FOLLOWING ITEMS,  
 SEE WIRING DIAGRAM (WIRING BOARD, SMD NO. 751-40-  
 ITEM 7 RIBBON CABLE  
 21 AFAC CABLE  
 22 AFACY CALL F ASST

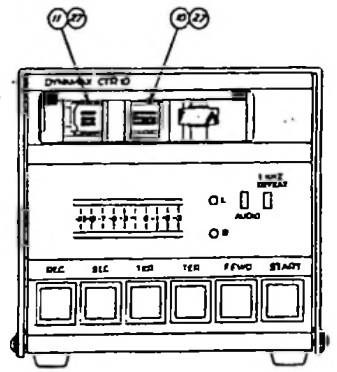
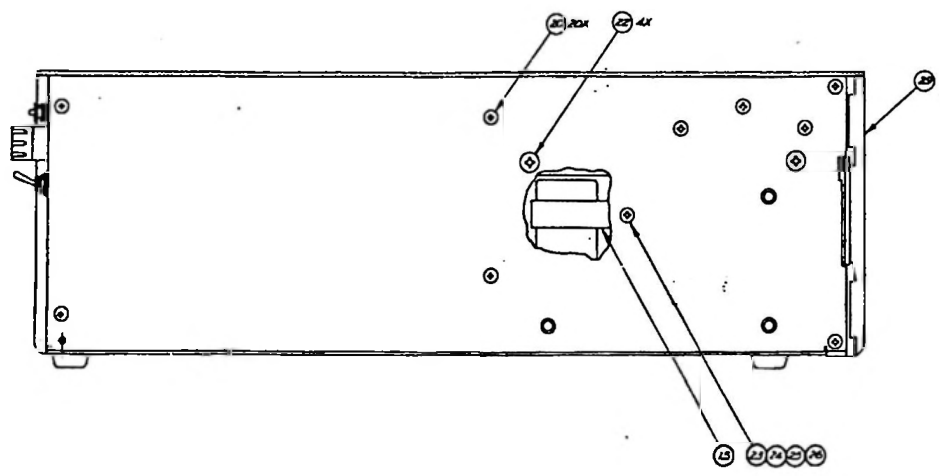

MANUFACTURER	ROCKWELL CORP
MODEL	W00PST0001, W1
PART NO.	TOP ASM, RP, STEREO - CTR LA
REV.	027-AD-009

PARTS LIST FOR TOP ASSEMBLY CTR10 SERIES **REPRODUCERS**  
SINGLE LEVEL BILL OF MATERIALS FOR PARENT ITEM NUMBER 847-A0-007

PART NUMBER	DESCRIPTION	QTY	SEQ
340-A0-002	PLAY HEAD STEREO	1	10
340-A0-004	DUMMY HEAD	1	38
42C-A0-001	RIBBON CABLE ASSEMBLY	1	7
525-A0-008	PARTITION COVER, CTR 10	1	13
525-C0-400	MOTOR SHIELD	1	6
525-C0-401	HEAD SHIELD	1	12
541-C0-018	PARTITION A	1	3
541-F0-022	SIDEPANEL LEFT	1	1
541-F0-023	SIDE PANEL RIGHT	1	2
581-A0-007	OVERLAY LOGO FRONT PANEL	1	0
581-A0-012	FRONT PANEL OVERLAY	1	
581-A0-013	LABEL, PARTITION COVER	1	14
5A4-A0-002	CARDGUIDE #400 BIVAR	1	8
5AB-A0-008	CAP THUMB SCREW	1	0
601-00-400	#4 FLAT WASHER STEEL PLATE	1	23
607-18-632	NUT CAPTIVE	4	9
621-04-440	SCREW Pan Head PHIL 4-40 X 1/4 SP	1	17
621-04-632	SCREW Pan Head PHIL 6-32 X 1/4 PL	10	18
621-0C-032	SCREW Pan Head PHIL 10-32 X 3/4 SP	2	19
645-03-632	SCREW Flat Head PHIL 6-32 X 3/16 SP	4	20
645-04-632	SCREW Flat Head PHIL 6-32 X 1/4 SP	20	20
645-04-832	SCREW Flat Head PHIL 8-32 X 1/4 SS	4	21
645-06-032	SCREW Flat Head PHIL 10-32 X 3/8 SS	4	22
6Y2-04-632	SCREW SOC HD CAP 6-32 X 1/4 BK	1	16
6Y2-16-632	SCREW SOC H.C. 6-32 X 1 3/8 BK	3	20
827-B0-000	HEAD BRIDGE ASSEMBLY	1	4
827-A0-067	PINCH ROLLER	1	6
837-B0-004	RECORD HEAD CABLE S	1	27
827-A0-026	ASM DECK CTR 10	1	28
827-A0-018	FRONT PANEL ASM	1	29
827-A0-024	REAR PANEL ASM	1	30
827-A0-022	MOTOR CTR 10	1	31
827-B0-023	TRANSFORMER ASM	1	32
807-E0-076	PLAY/CUE/LOGIC	1	33
807-B0-105	PWA MOTHER	1	35
827-A0-021	HEAT SINK	1	36
837-A0-011	ASM READY CABLE	1	37

REVISED DESIGN	DATE

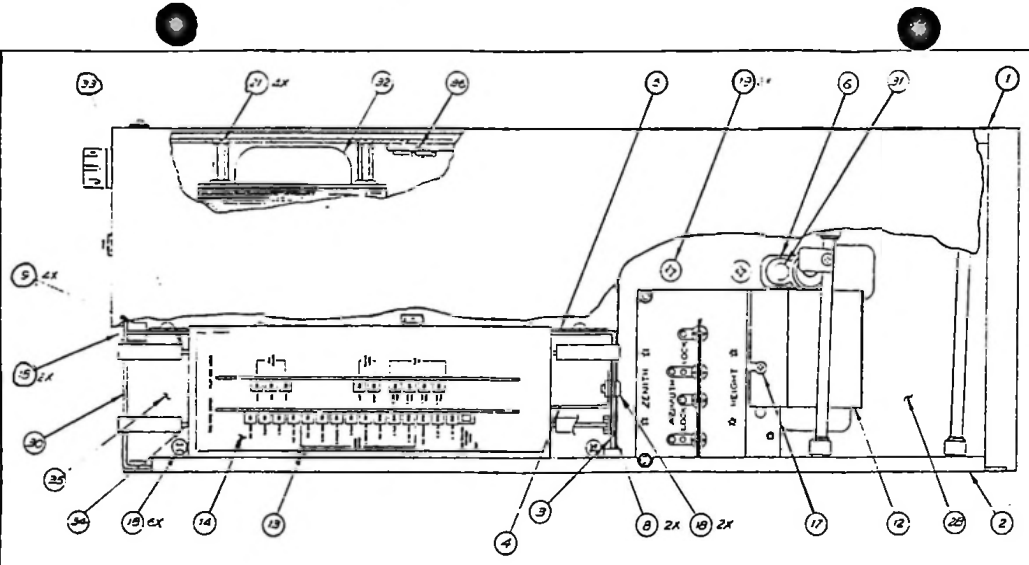

NOTES:  
 1 FOR CABLE CONNECTIONS OF THE FOLLOWING ITEMS  
 SEE WIRING DIAGRAM & OTHER BOARD, C.M.S. NO. 151-40-  
 ITEM 7 RIBBON CABLE  
 27 HEAD CABLE  
 27 HEAD CABLE ASH

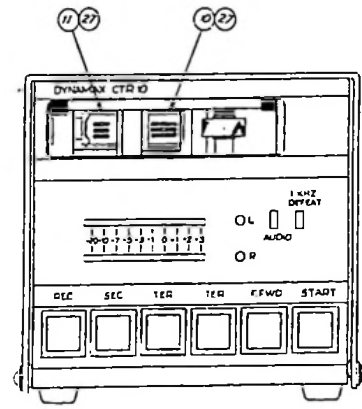
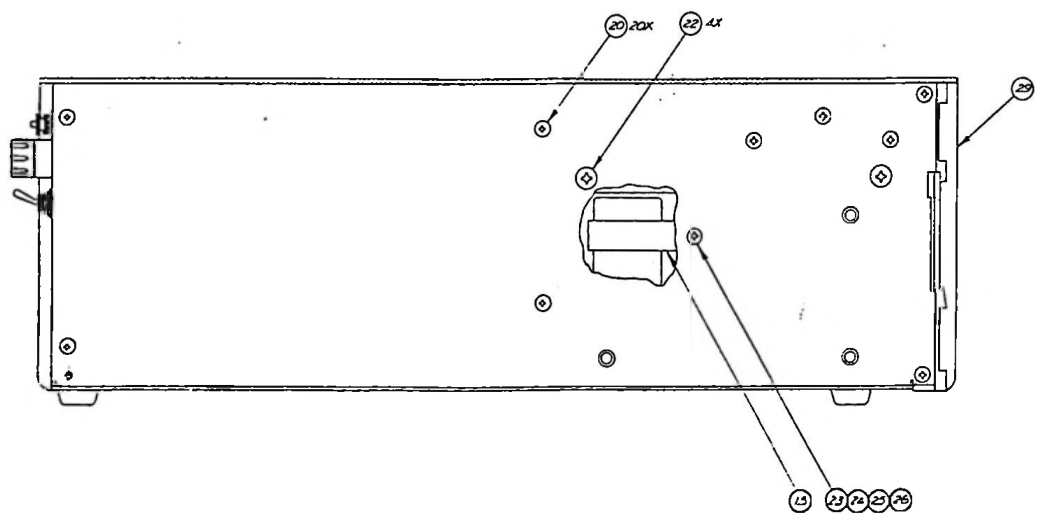

REVISION	1	1500	1500
DATE	1-1-56	1500	1500
BY	J. J. B.	1500	1500
CHECKED	J. J. B.	1500	1500
APPROVED	J. J. B.	1500	1500
TOP ASM, RP STEREO-CTR 14			
C.17-40-009			

PARTS LIST FOR TOP ASSEMBLY CTR10 SERIES RECORDERS

SINGLE LEVEL BILL OF MATERIALS FOR PARENT ITEM NUMBER 847-A0-009

PART NUMBER	DESCRIPTION	QTY	SEQ
340-A0-002	PLAY HEAD STEREO	1	10
340-A0-003	RECORD HEAD STEREO	1	11
42C-A0-001	RIBBON CABLE ASSEMBLY	2	7
525-A0-008	PARTITION COVER, CTR 10	1	13
525-C0-400	MOTOR SHIELD	1	6
525-C0-401	HEAD SHIELD	1	12
541-B0-034	PARTITION SHIELD, CTR10	1	4
541-C0-018	PARTITION A	1	3
541-F0-022	SIDEPANEL LEFT	1	1
541-F0-023	SIDE PANEL RIGHT	1	2
581-A0-007	OVERLAY LOGO FRONT PANEL	1	0
581-A0-012	FRONT PANEL OVERLAY, CTR10 RP VU	1	
581-A0-013	LABEL, PARTITION COVER	1	14
581-B0-009	FRONT PANEL OVERLAY, CTR10 RP VU	1	11
5A4-A0-002	CARDGUIDE #400 BIVAR	2	8
5AB-A0-008	CAP THUMB SCREW	1	0
601-00-400	#4 FLAT WASHER STEEL PLATE	1	23
607-18-632	NUT CAPTIVE	4	9
621-04-440	SCREW P.H. PHIL 4-40 X 1/4 SP	1	17
621-04-632	SCREW P.H. PHIL 6-32 X 1/4 PL	10	18
621-0C-032	SCREW P.H. PHIL 10-32 X 3/4 SP	2	19
645-03-632	SCREW FL PHIL 6-32 X 3/16 SP	4	20
645-04-632	SCREW FL PHIL 6-32 X 1/4 SP	20	20
645-04-832	SCREW FL PHIL 8-32 X 1/4 SS	4	21
645-06-032	SCREW FL PHIL 10-32 X 3/8 SS	4	22
6Y2-04-632	SCREW SOC HD CAP 6--32 X 1/4 BK	1	16
6Y2-16-632	SCREW SOC H.C. 6-32 X 1 3/8 BK	2	20
807-B0-106	PWA MOTHER, CTR 13/14	1	35
807-C0-081	RECORD AMP STEREO	1	34
807-E0-076	PLAY/CUE/LOGIC	1	33
827-A0-020	FRONT PANEL ASM	1	29
827-A0-021	HEAT SINK ASM CTR10	1	36
827-A0-022	MOTOR CTR 10	1	31
827-A0-024	REAR PANEL ASM	1	30
827-A0-026	DECK ASM CTR 10	1	28
827-A0-067	PINCH ROLLER	1	6
827-B0-000	HEAD BRIDGE ASSEMBLY	1	4
837-B0-006	RECORD CABLE S	1	0
827-B0-023	TRANSFORMER ASM	1	32
837-A0-011	READY CABLE ASM	1	37
837-B0-004	RECORD HEAD CABLE S	1	27

DATE	BY	REVISION	APPROVED

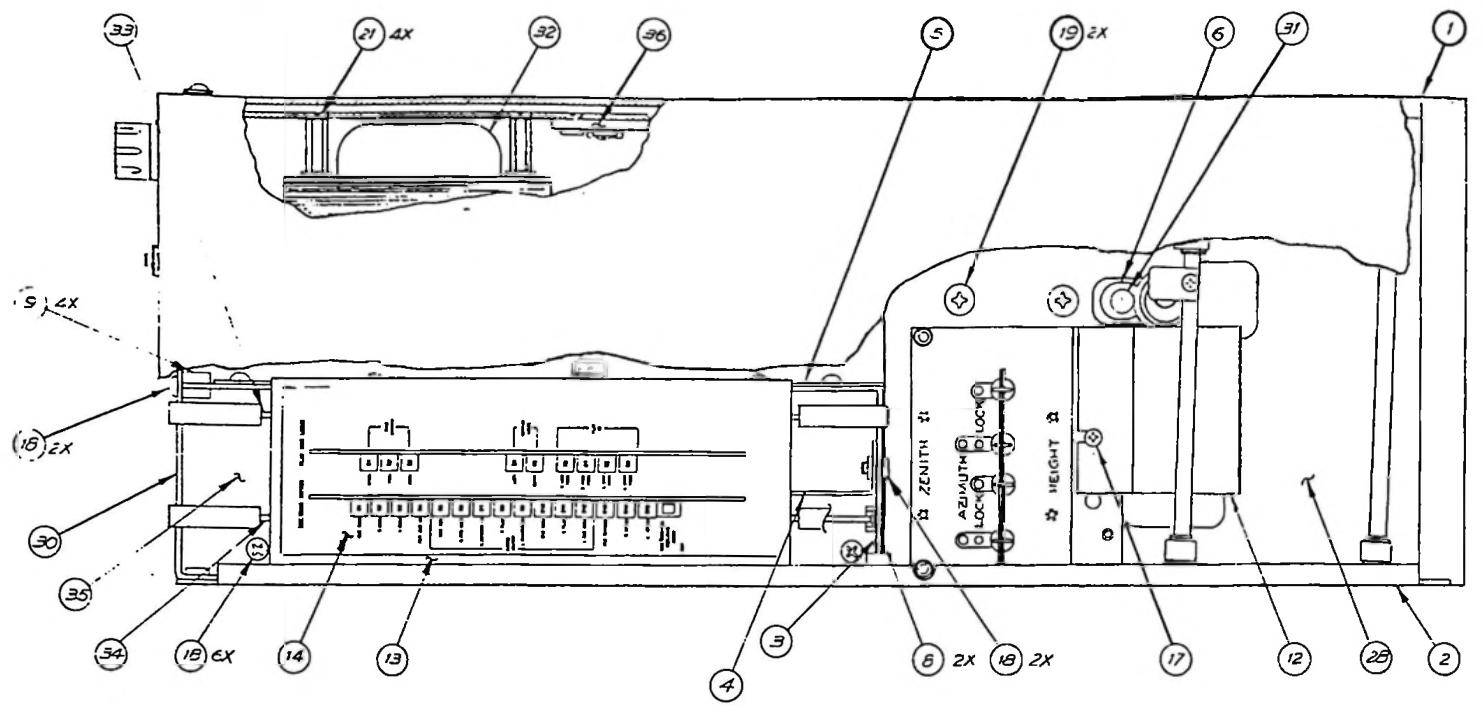

NOTES:  
 1. FOR CABLE CONNECTIONS OF THE FOLLOWING ITEMS  
 SEE WIRING DIAGRAM ANOTHER BOARD, DWG. NO. 751-10-  
 ITEM 7 RIBBON CABLE  
 27 HEAD CABLE  
 27 HEAD CABLE  
 27 HEAD CABLE

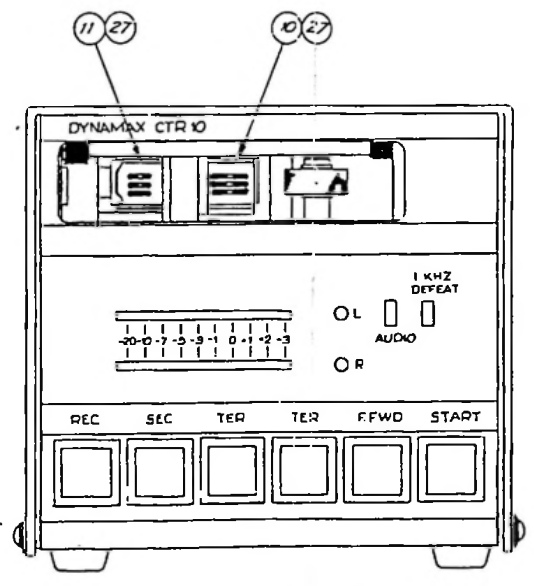
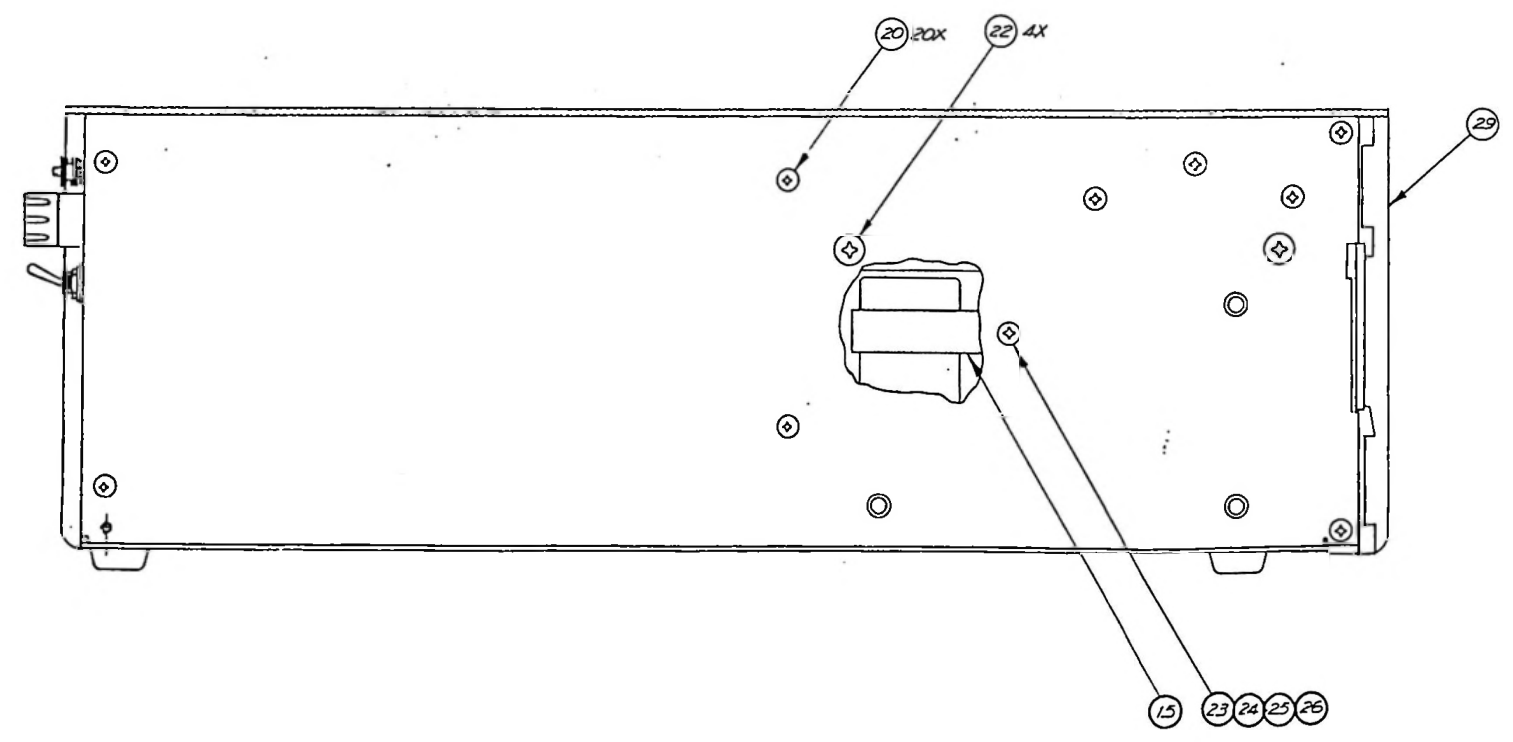

DESIGNED BY	FIDELIPAC CORP. MOORESTOWN, N.J.		
DRAWN BY			
CHECKED BY			
TITLE	TOP ASM, RP STEREO-CTR 10		
DATE	3 JAN 66	DRAWING NUMBER	847-10-009

REVISION RECORD		DATE	BY

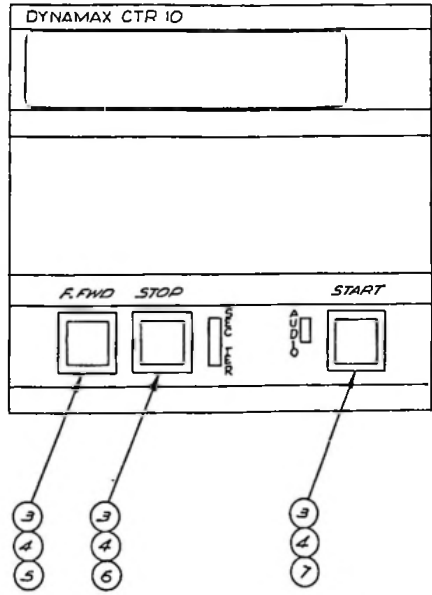
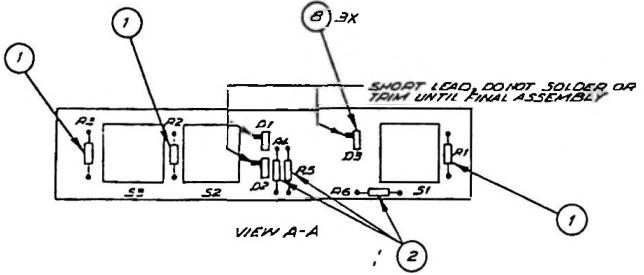
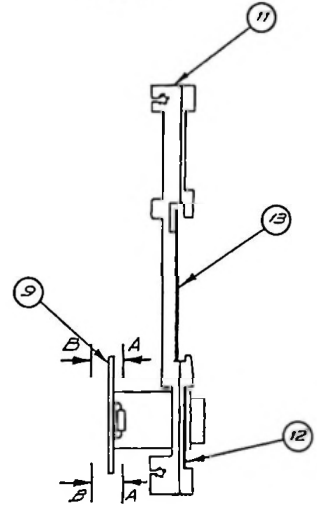
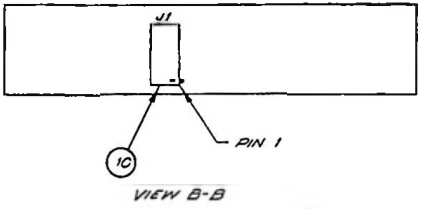

VOLUNTEER		FIDELIRAC CORP MCGRESTOWN, N.J.	
DESIGN	DATE	DRAWN BY	CHECKED BY
PREPARED BY	TITLE	FRONT PANEL, ASM, P, CTR:10	
APPROVED	DATE	DRAWING NUMBER	
		827-A0-018	



FRONT PANEL ASSEMBLY CTR10 SERIES **REPRODUCERS**

FOR PARENT ITEM NUMBER 827-A0-018

ITEM NUMBER	DESCRIPTION	QTY	SEQ	Designation
110-22-130	13 1/4W 5% CF Resistor	3	1	R1, R2, R3
110-32-681	680 1/2W 5% CF Resistor	3	2	R4, R5, R6
250-A0-004	GREEN LED	3	8	D1, D2, D3
260-A0-001	382 LAMP	3	3	S1, S2, S3
364-A0-005	SWITCH PUSH BUTTON LIGHTED	3	4	S1, S2, S3
364-A0-006	LENS - SWITCH WHITE	1	5	S3
364-A0-007	LENS - SWITCH RED	1	6	S2
364-A0-008	LENS SWITCH GREEN	1	7	
407-A0-085	PCB, SWITCH P	1	9	
410-A0-003	SOCKET DIP 16 PIN	1	10	J1
532-B0-007	FRONT PANEL REPRODUCER	1	11	
581-A0-011	SWITCH OVERLAY, P	1	12	
581-A0-012	FRONT PANEL OVERLAY, CTR10, BLANK P	1	13	

DATE	REV	REVISION RECORD	AUTH	OR	CHK

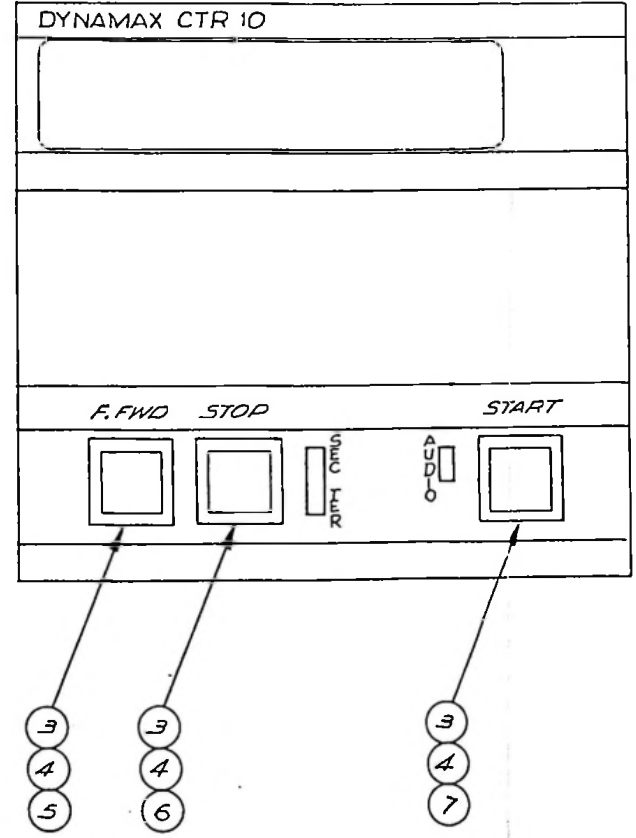
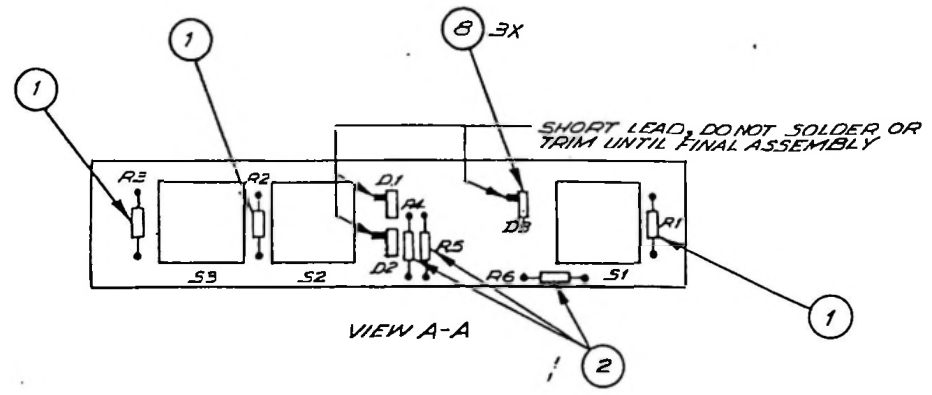
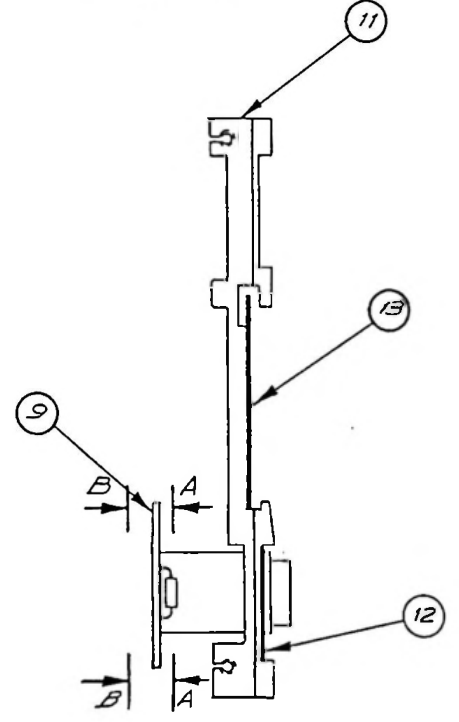
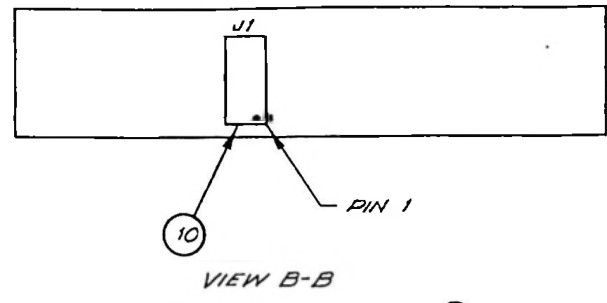

TOLERANCES UNLESS OTHERWISE SPECIFIED	FIDELIPAC CORP MOORESTOWN, N.J.		
DECIMAL	SCALE	DRAWN BY	
FRACTIONAL		APPROVED BY	
ANGULAR	DATE	DRAWING NUMBER	
		827-A0-018	

REV	DESCRIPTION	DATE	BY

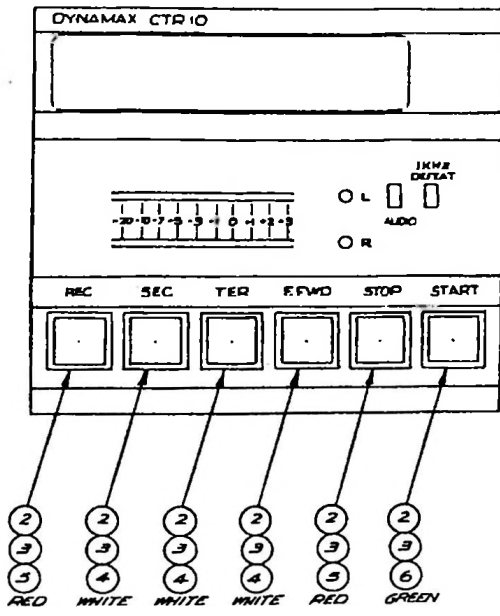
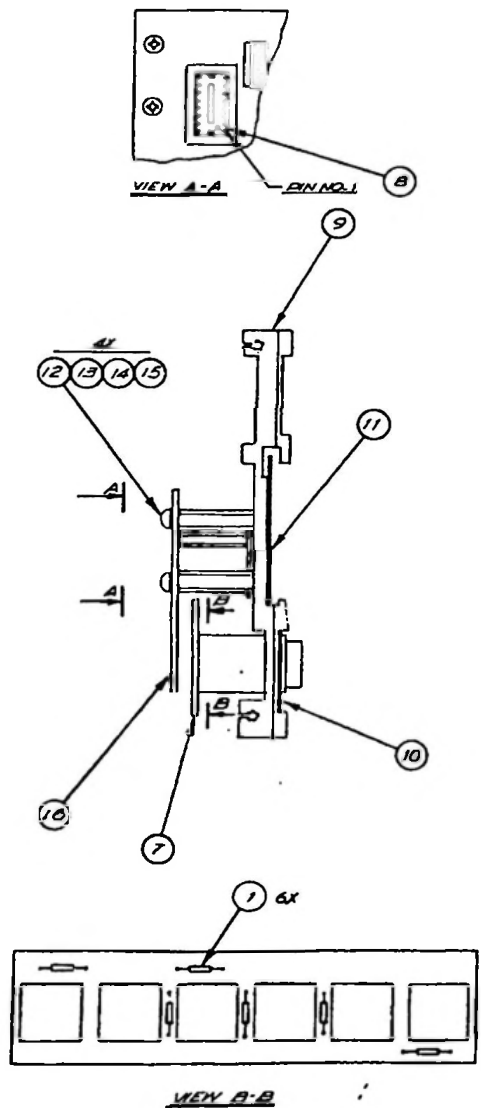

FIDELIRAC CORP MOORESTOWN, N.J.	
DESIGNED BY	DATE
DRAWN BY	APPROVED BY
FRONT PANEL ASM R15, CTR 13 & 14	
DATE	REV. NO.
21 NOV 85	027-A0-020

FRONT PANEL ASSEMBLY CTR10 SERIES **RECORDERS**

FOR PARENT ITEM NUMBER 827-A0-020

ITEM NUMBER	DESCRIPTION	QTY	SEQ	Designation
110-22-130	13 1/4W 5% CF Resistor	6	1	R1 thru R6
260-A0-001	LAMP 382	6	2	S1 thru S6
364-A0-005	SWITCH PUSH BUTTON LIGHTED	6	3	S1 thru S6
364-A0-006	LENS - SWITCH WHITE	3	4	S3, S4, S5
364-A0-007	LENS - SWITCH RED	2	5	S2, S6
364-A0-008	LENS SWITCH GREEN	1	6	S1
407-A0-090	PCB, SWITCH R/P	1	7	
410-A0-003	16 PIN DIP SOCKET	1	8	J1
532-B0-008	FRONT PANEL RECORDER	1	9	
581-A0-010	SWITCH OVERLAY, R/P	1	10	
5B2-A0-006	SPACER HEX 1/4 X 7/8 6-32 ALUM	4	12	
601-00-600	#6 FLAT WASHER STEEL PLATE	4	17	
60C-11-600	LOCK WASHER I.T. #6	4	13	
621-04-632	SCREW P.H. PHIL 6-32 X 1/4 PL	4	14	
645-04-632	SCREW P.H. FL 6-32 X 1/4 SP	4	15	
807-A0-101	VU PWA STEREO	1	16	

DATE	BY	REVISION RECORD	AUTH	OR	CHK

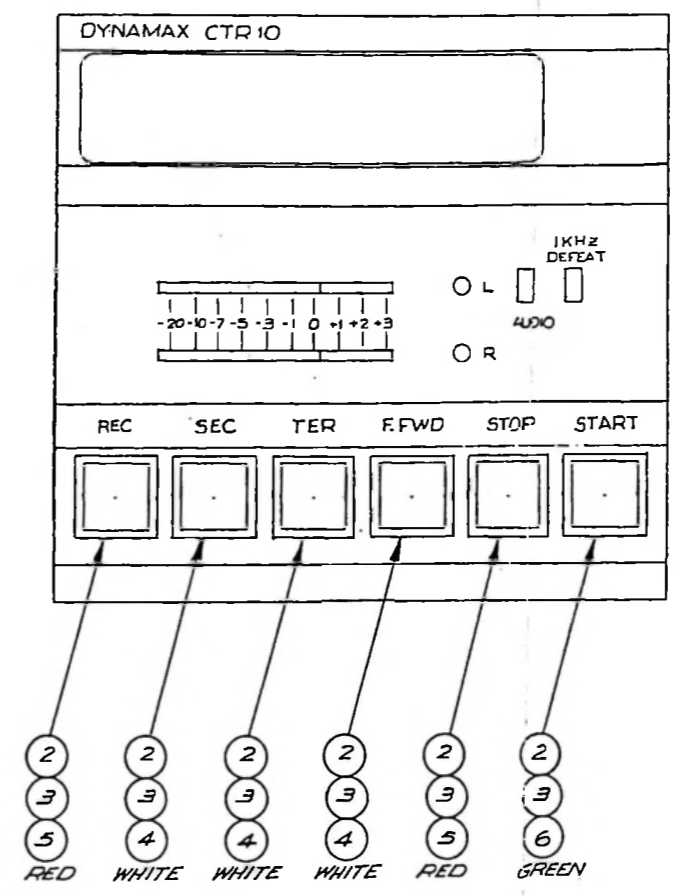
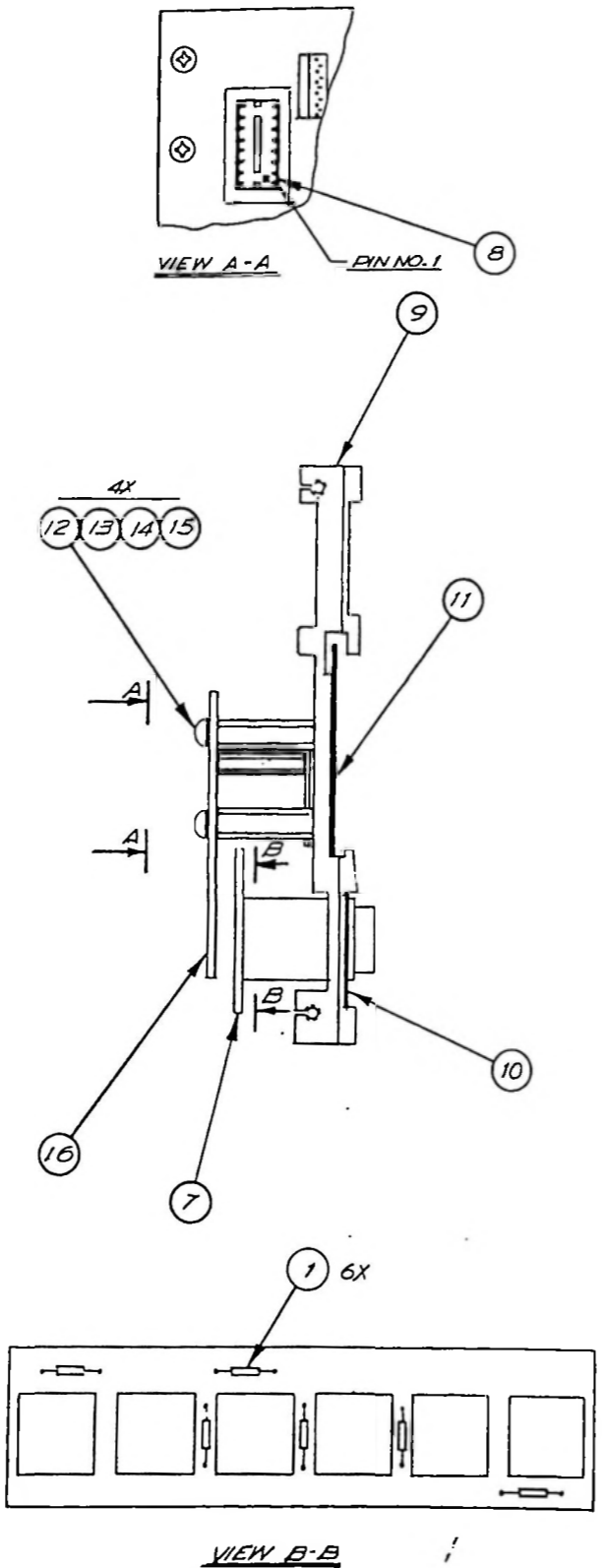

TOLERANCES	FIDELIFAC CORP. MOORESTOWN, N.J.	
DECIMAL	SCALE	DRAWN BY
FRACTIONAL	TITLE	APPROVED BY
ANGULAR	DATE	DRAWING NUMBER
	21 NOV 85	827-A0-020

HEAD BRIDGE ASSEMBLY CTR10 SERIES

ASSY NUMBER 827-F0-401 HEAD BRIDGE ASSEMBLY (REVISED 1/20/99)

PART NUMBER	DESCRIPTION	QTY	SEQ
501-B0-402	HEAD LOCKING BLOCK	2	1
501-E0-400	BEARING BLOCK, PLASTIC	2	2
502-C0-400	HEAD SHAFT	2	3
512-F0-400	HEAD BRIDGE, FINISHED	1	4
512-F1-400	HEAD BRIDGE, PLATED	1	4
512-F2-400	HEAD BRIDGE, PLASTIC	1	4
570-B0-400	HEIGHT ZENITH BEAM	2	5
570-B0-402	THRUST PLATE	2	6
570-C0-401	HEAD CLAMP	2	7
571-B0-405	AZIMUTH BEAM	2	8
5AB-A0-001	TAPE GUIDE, CURVED	1	9
5AB-A0-002	TAPE GUIDE STRAIGHT	1	10
5B6-A0-400	BALL 3/16	2	11
5E2-04-148	SPRING COMP .1480 X 1/4	2	12
5E2-A0-400	SPRING, ZENITH BEAM	4	13
5E2-A0-401	SPRING, AZIMUTH	2	14
5E2-A0-402	SPRING, PENETRATION	2	15
601-00-400	#4 FLAT WASHER STL PLATE	4	16
605-00-231	FLAT WASHER SS .187 OD	2	17
645-A0-440	SCREW FL PHIL 4-40 X 1/4 SS	4	18
662-08-540	SCREW 5-40 X 1/2 82 FH SOC	4	19
681-06-440	SCREW 4-40 X 3/8 PBH STL	4	20
6G2-04-832	SCREW SET 8-32 X 1/4 FLT TIP	2	21
6G2-06-832	SCREW SET 8-32 X 3/8 FLT TIP	2	22
6Y2-0A-256	SCREW SOC HC 2-56 X 5/8 BLK	4	23
6Y2-10-256	SCREW SOC HC 2-56 X 1 BLK	4	24

ALL ADJUSTING / LOCKING SCREWS  
 SOCKET HEAD 5/64

AZIMUTH ADJUSTMENT  
 SCREWS  
 ZENITH ADJUSTMENT SCREWS

INSERTION  
 ADJUSTMENT  
 SCREWS  
 USE FIDELIPAC HEAD  
 INSERTION GAGE NO. 328

HEAD BRIDGE  
 MTG. SCREW (SOC. NO. 7/64)  
 HEIGHT ADJUSTMENT SCREWS

TAPE GUIDE ADJUSTMENT  
 SCREWS  
 HEAD CLAMPING SCREWS  
 HEADS ARE INSTALLED SEATED AGAINST  
 CLAMPING SCREWS

TAPE GUIDE ADJUSTMENT  
 ALIGN TOP EDGE OF GUIDE WITH  
 TOP OF GAGE

RECORD  
 HEAD LOCKING SCREW  
 LOOSEN THIS SCREW (BOTH SIDES)  
 BEFORE MAKING ANY ADJUSTMENTS

HEAD HEIGHT ADJUSTMENT  
 ALIGN TOP OF TRACK WITH  
 TOP OF GAGE

HEAD ZENITH ADJUSTMENT  
 SQUARE FACE OF HEAD WITH  
 FACE OF GAGE

DWC. NO.	750-80-440	APPR. T.J.W.
SHEET	2 OF 2	ISSUE DATE 2/6/91

MECHANICAL ALIGNMENT LOCATIONS

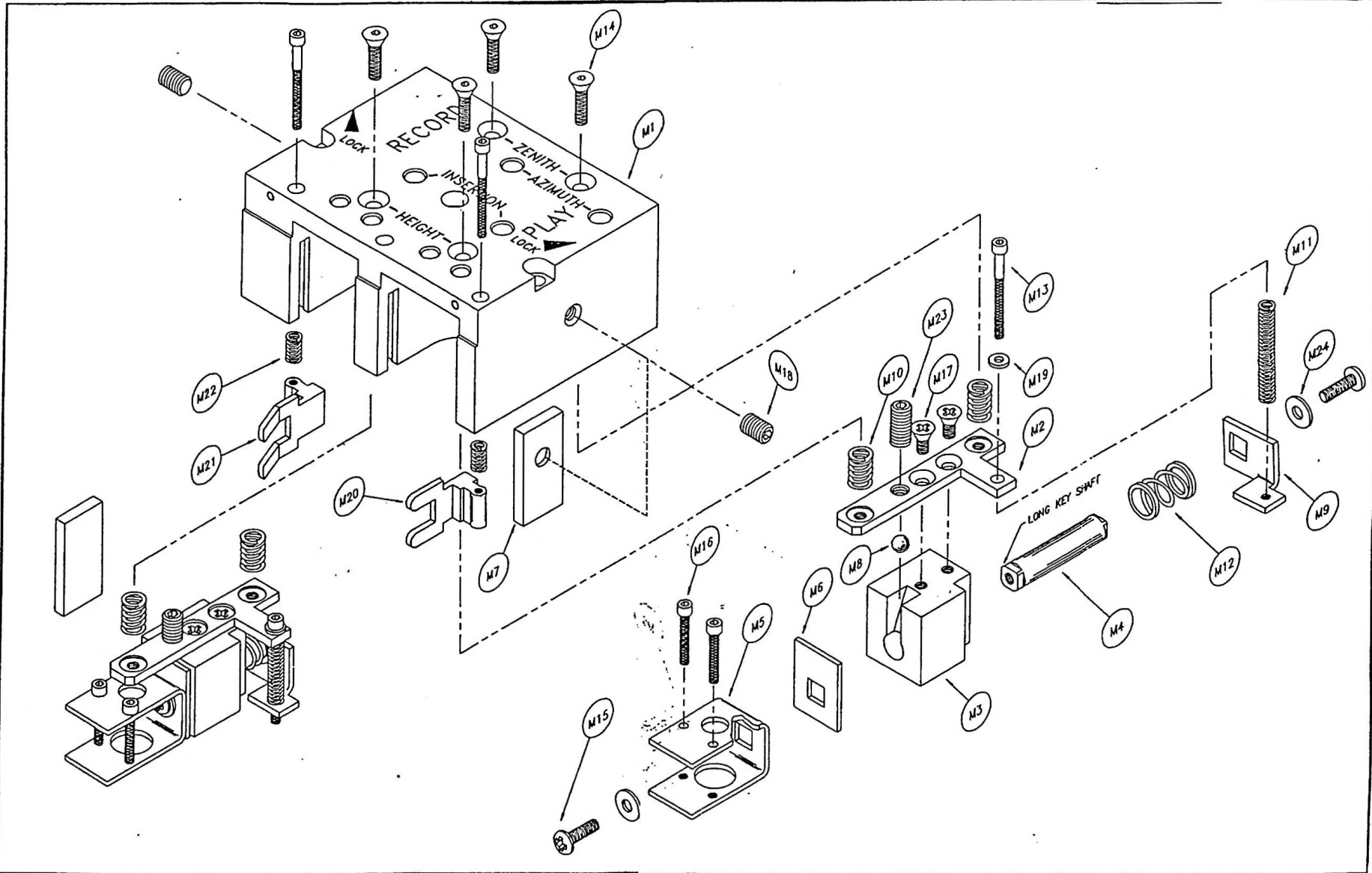

MODEL NOS. ALL MODELS	ASSEMBLY HEAD BRIDGE	DWG. NO. 827-00-401	APPR. <i>J.J.V.</i>	Example	FIDELIPAC CORP. MOORESTOWN, N.J.	THIS DOCUMENT CONTAINS PROPRIETARY INFORMATION OF FIDELIPAC CORPORATION. NO USE, DISCLOSURE OR REPRODUCTION OF ANY PART THEREOF MAY BE MADE WITHOUT WRITTEN PERMISSION.
			2/6/01			



FIDELIPAC CORPORATION - INDENTED BILL OF MATERIAL

ASSY NUMBER 827F0401

HEAD BRIDGE ASSY, PLASTIC

REV

DATE 01/20/99

TYPE	PART NUMBER	QTY	UOM	DESCRIPTION	NEXT ASSY	CIR SYM	CODE	BOX	R/N
	501B0402	2	EA	HEAD LOCKING BLOCK	827F0401		1		K
	501E0400	2	EA	BEARING BLOCK, PLASTIC	827F0401		5		K
	502C0400	2	EA	HEAD SHAFT CTR90	827F0401		5		K
A	512F0400	1	EA	HEAD BRIDGE FINISHED	827F0401		5		K
	. 512F1400	1	EA	HEAD BRIDGE (PLATED)	512F0400		5		N
	. 512F2400	1	EA	HEAD BRIDGE (PLASTIC)	512F0400		5		N
	570B0400	2	EA	HEIGHT ZENITH BEAM	827F0401		1		K
	570B0402	2	EA	THRUST PLATE, CTR90	827F0401		1		K
	570C0401	2	EA	HEAD CLAMP, CTR 90	827F0401		1		K
	571B0405	2	EA	AZIMUTH BEAM	827F0401		1		K
	5ABA0001	1	EA	TAPE GUIDE CURVED	827F0401		1		K
	5ABA0002	1	EA	TAPE GUIDE STRAIGHT	827F0401		1		K
	5B6A0400	2	EA	BALL 3/16	827F0401		1		K
	5E204148	2	EA	SPRING COMP .1480 X 1/4	827F0401		1		K
	5E2A0400	4	EA	SPRING, ZENITH BEAM	827F0401		1		K
	5E2A0401	2	EA	SPRING, AZIMUTH	827F0401		1		K
	5E2A0402	2	EA	SPRING, PENETRATION	827F0401		1		K
	60100400	4	EA	1/4 FLAT WASHER STL PLATE	827F0401		1		K
	60500231	2	EA	FLAT WASHER SS .187 OD	827F0401		1		K
	645A0440	4	EA	SCREW FL PHIL 4-40X1/4 SS	827F0401		1		K
	66208540	4	EA	SCRW 5-40X1/2 82 FH SOC	827F0401		1		K
	68106440	4	EA	SCRW 4-40X3/8 PBH STL	827F0401		1		K
	6G204832	2	EA	SCRW SET 8-32X1/4 FLT TIP	827F0401		1		K
	6G206832	2	EA	SCRW SET 8-32X3/8 FLT TIP	827F0401		1		K
	6Y20A256	4	EA	SCRW SOC HC 2-56X5/8 BLK	827F0401		1		K
	6Y210256	4	EA	SCRW SOC HC 2-56 X 1 BLK	827F0401		1		K

HEAD BRIDGE ASSEMBLY      827-C0-401

DESCRIPTION	QTY	DESIGNATOR	PART NUMBER
BEARING BLOCK	2	M3	501-A0-400
HEAD LOCKING BLOCK	2	M7	501-A0-402
HEAD SHAFT	2	M4	502-B0-400
HEAD BRIDGE	1	M1	512-C0-400
HEIGHT ZENITH BEAM	2	M2	570-A0-400
HEAD CLAMP	2	M5	570-B0-401
THRUST PLATE	2	M6	570-B0-402
AZIMUTH BEAM	2	M9	571-B0-405
TAPE GUIDE CURVED	1	M21	5AB-A0-001
TAPE GUIDE STRAIGHT	1	M20	5AB-A0-002
BALL 3/16	2	M8	5B6-A0-400
SPRING COMP .1480 X 1/4	2	M22	5E2-04-148
SPRING, ZENITH BEAM	4	M10	5E2-A0-400
SPRING, AZIMUTH	2	M11	5E2-A0-401
SPRING, PENETRATION	2	M12	5E2-A0-402
FLAT WASHER SS .187 OD	2	M19	605-00-231
SCREW FL PHIL 4-40 X 1/4 SS	4	M17	645-A0-440
SCREW, 4-40X1/2 1820 FHP BLK	4	M14	64H-08-440
SCREW, 4-40X3/8 PBH STL	4	M15	681-06-440
SCREW, 4-40X5/16 SHS BLK	2	M18	6G2-05-440
SCREW SH 4-40X3/8 BL	2	M23	6Y2-06-440
SCREW SOC H.C. 2-56 X 1 BLK	4	M13	6Y2-10-256
SCREW SOC H.C. 2-56 X 5/8 BLK	4	M16	6Y2-0A-256
# 4 FLAT WASHER, STEEL PLATE	4	M24	601-00-400

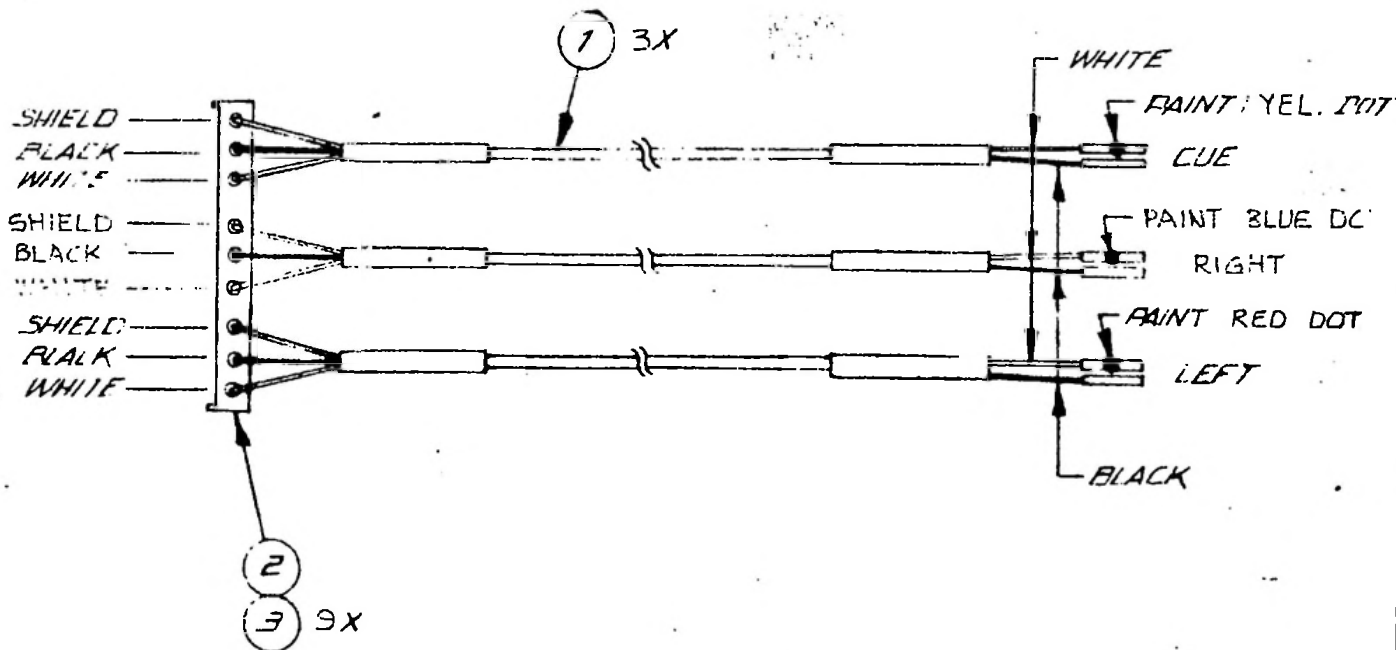

TOLERANCES (EXCEPT AS NOTED)	REVISIONS			FIDELIPAC CORP MIDDLETOWN, NJ		
	NO.	DATE	BY			
DECIMAL	1			REC. HD. CABLE ASM ST. REC		
±	2					
FRACTIONAL	3			DRAWN BY <i>J.R.</i>	SCALE	MATERIAL
±	4			CHK'D	DATE 3/14/87	DRAWING NO
ANGULAR	5			TRACES	APP'D	837-CO-004
±						

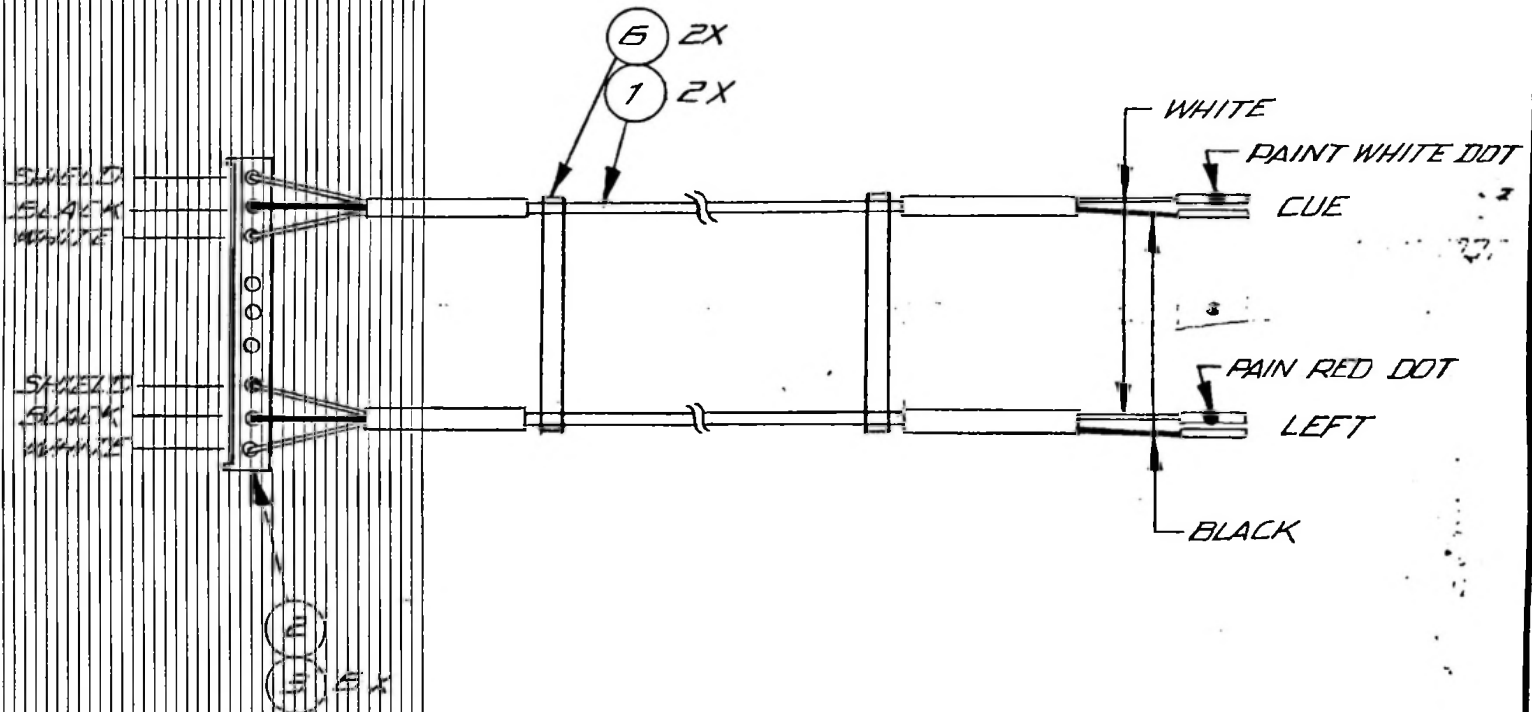

TOLERANCES (EXCEPT AS NOTED)	REVISIONS			FIDELIPAC CORP MIDDLETOWN, N.J.		
	NO.	DATE	BY			
DECIMAL	1			REC. HD. CABLE ASM MOND		
±	2					
FRACTIONAL	3			DRAWN BY <i>LET</i>	SCALE	MATERIAL
±	4			CHK'D	DATE 9 AUG 84	DRAWING NO.
ANGULAR	5			TRACED	APP'D	837-80-003
±						

CTR 100, CTR 10

DATE	BY	REVISION RECORD	AUTH	DR	CH
7/1/55	5	REVISED PER EGN 016	JAG		

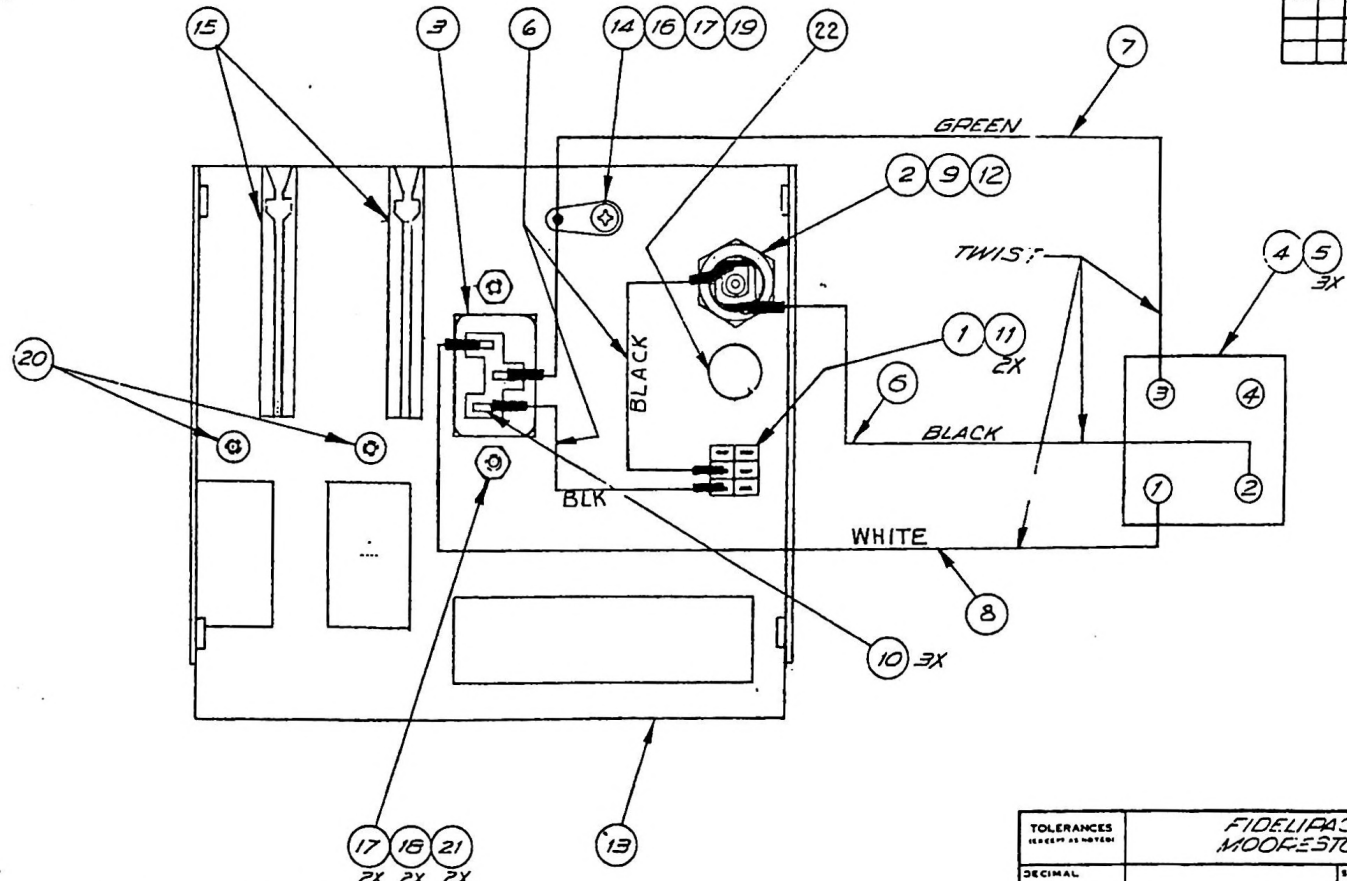

NOTES.

- 1 - SILK SCREEN PER 770-A0-035 BEFORE ASSEMBLY.
- 2 - 120V. WIRING SHOWN.

TOLERANCES (SEE NOTE 1)	FIDELIFAC CORP. MOORESTOWN, N.J.		
DECIMAL ± ~	SCALE ~	DRAWN BY: JZ APPROVED BY:	
FRACTIONAL ± ~	TITLE REAR PANEL ASM-CTR:ID		
ANGULAR ± ~	DATE 19NOV55	DRAWING NUMBER 827-30-024	

REAR PANEL ASSEMBLY CTR10 FOR 110 V OPERATION

FOR PARENT ITEM NUMBER 827-B0-024

ITEM NUMBER	DESCRIPTION	QTY	SEQ	Desig
360-A0-001	TOGGLE SWITCH	1	1	
371-A0-001	FUSE 1A SLOW BLOW	1	2	
413-A0-000	AC CONNECTOR, 3 PIN RECEPT.	1	3	
414-A0-007	TERMINAL, MR	3	5	
415-A0-014	HOUSING, 4 PIN MR	1	4	
417-A0-004	HOLE PLUG	1	22	H1
423-A2-20N	WIRE Stranded 22 AWG BLACK	20	6	
423-A2-25N	WIRE Stranded 22 AWG GREEN	16	7	
423-A2-29N	WIRE Stranded 22 AWG WHITE	12	8	
430-A0-000	FUSE HOLDER PANEL MOUNT 3AG	1	9	
44S-A0-000	HEAT SHRINK TUBING 3/16	2	10	
44S-A0-001	HEAT SHRINK TUBING 1/8	1	11	
44S-A0-002	HEAT SHRINK TUBING 3/4	1	12	
541-E0-035	REAR PANEL CTR10	1	13	
5A2-A0-000	TYE WRAP 1/16 TO 2" DIA.	3	23	
5A2-A0-006	GROUND LUG	1	14	
5A4-A0-001	CARD GUIDE #250 BIVAR	2	15	
600-33-632	THUMB NUT 6-32	1	16	
601-20-632	HEX NUT 6-32 STEEL PLATE	3	17	
60C-11-600	LOCK WASHER I.T. #6	2	18	
621-03-632	SCREW P.H. PHIL 6-32 X 3/16 PL	2	20	
621-06-632	SCREW P.H. PHIL 6-32 X 3/8 ZP	2	21	
621-08-632	SCREW P.H. PHIL 6-32 X 1/2 LG STL	1	19	

DATE	SYM	REVISION RECORD	AUTH.	DR.	CK.
7/1/88	B	REVISED PER ECN 036	JMM		

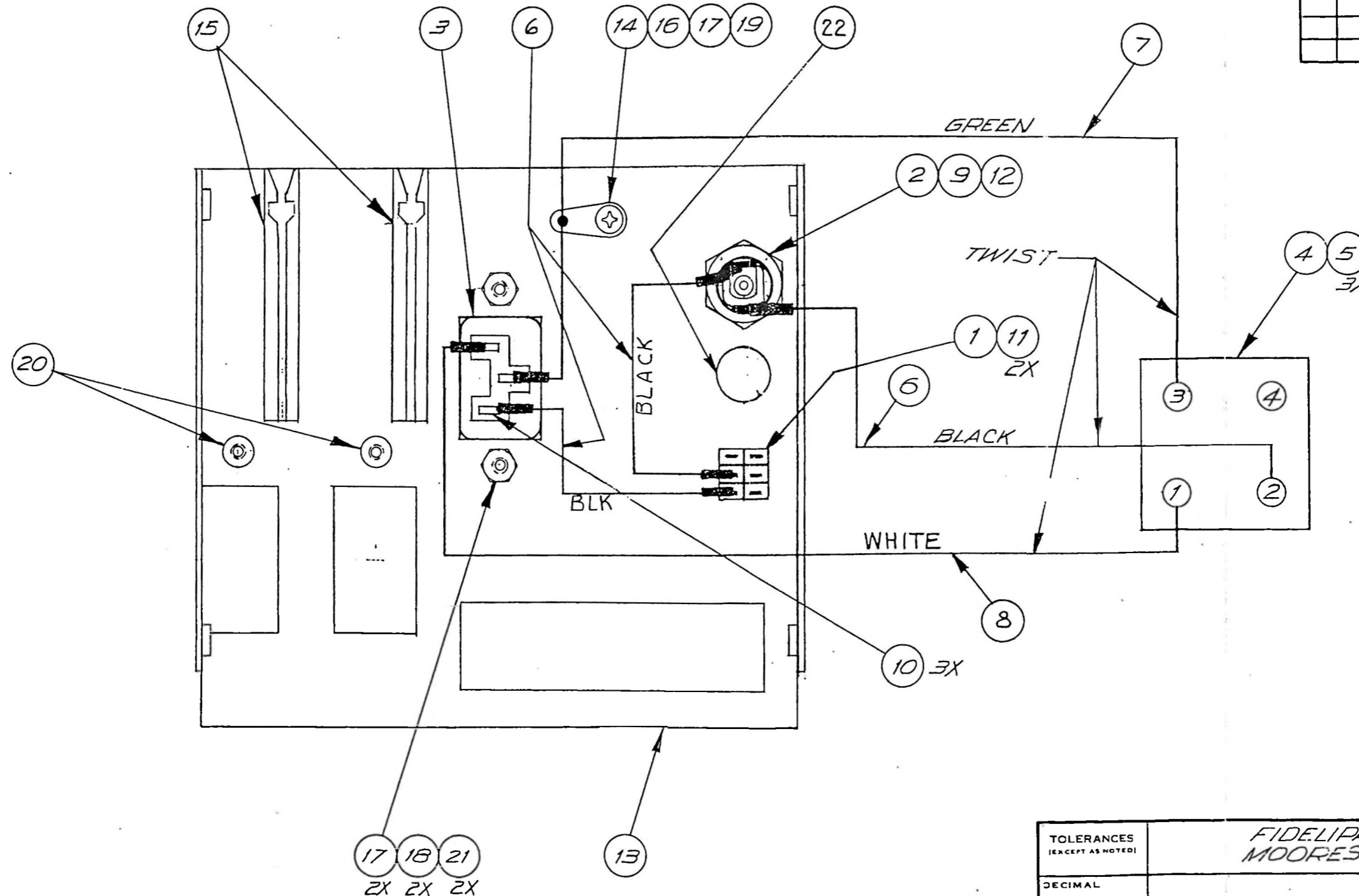

NOTES:

- 1 - SILK SCREEN PER 770-A0-035 BEFORE ASSEMBLY.
- 2 - 120V. WIRING SHOWN.

TOLERANCES (EXCEPT AS NOTED)		FIDELIPAC CORP. MOORESTOWN, N.J.	
DECIMAL	± ~	SCALE	~
FRACTIONAL	± ~	DRAWN BY	J
ANGULAR	± ~	APPROVED BY	
TITLE		REAR PANEL ASM-CTR 10	
DATE	19NOV65	DRAWING NUMBER	827-80-024

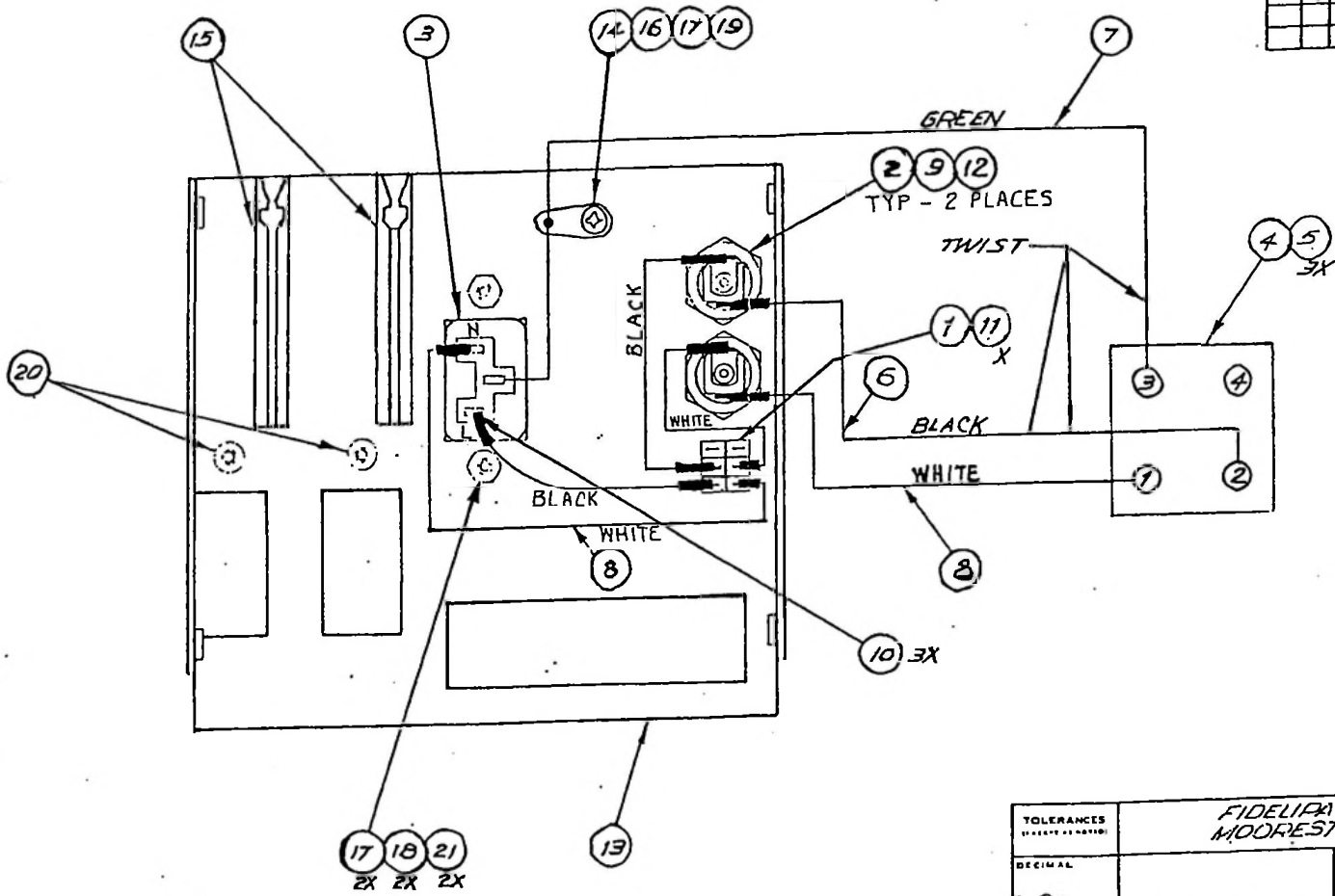

NOTES:  
 1 - SILK SCREEN PER 770-A0-035  
 BEFORE ASSEMBLY.  
 2 - 240V. WIRING SHOWN.

TOLERANCES UNLESS OTHERWISE SPECIFIED		FIDELIPAC CORP MOORESTOWN, N.J.	
DECIMAL		SCALE	DRAWN BY: <i>D. Panchal</i>
FRACTIONAL			APPROVED BY:
ANGULAR		DATE	DRAWING NUMBER
		5/31/88	827-A0-068



REAR PANEL ASSEMBLY CTR10 FOR 220 V OPERATION

FOR PARENT ITEM NUMBER 827-A0-068

ITEM NUMBER	DESCRIPTION	QTY	SEQ	Desig
360-A0-001	TOGGLE SWITCH	1	1	
371-A0-003	FUSE .5A SLOW BLOW	2	2	
413-A0-000	CONNECTOR AC - 3 PIN RECEPT.	1	3	
415-A0-014	HOUSING, 4 PIN MR	1	4	
414-A0-007	TERMINAL, MR	3	5	
423-A2-20N	STRANDED WIRE 22 AWG BLACK	20	6	
423-A2-25N	STRANDED WIRE 22 AWG GREEN	15	7	
423-A2-29N	STRANDED WIRE 22 AWG WHITE	18	8	
430-A0-000	FUSE BOLDER PANEL MOUNT 3AG	2	9	
44S-A0-000	TUBING HEAT SHRINK 3/16	3	10	
44S-A0-001	TUBING HEAT SHRINK 1/8	2	11	
44S-A0-002	TUBING HEAT SHRINK 3/4	2	12	
541-E0-035	REAR PANEL CTR10	1	13	
5A2-A0-006	GROUND LUG	1	14	
5A4-A0-001	CARD GUIDE #250 BIVAR	2	15	
600-33-632	NUT THUMB 6-32	1	16	
601-20-632	NUT HEX 6-32 STEEL PLATE	3	17	
60C-11-600	LOCK WASHER I.T. #6	2	18	
621-08-632	SCREW P.H. PHIL 6-32 X 1/2 LG STL	1	19	
621-03-632	SCREW P.H. PHIL 6-32 X 3/16 PL	2	20	
621-06-632	SCREW P.H. PHIL 6-32 X 3/8 ZP	2	21	
5A2-A0-000	TY WRAP 1/16 TO 2" DIA.	3	23	

DATE	SYM	REVISION RECORD	AUTH	DR	CK

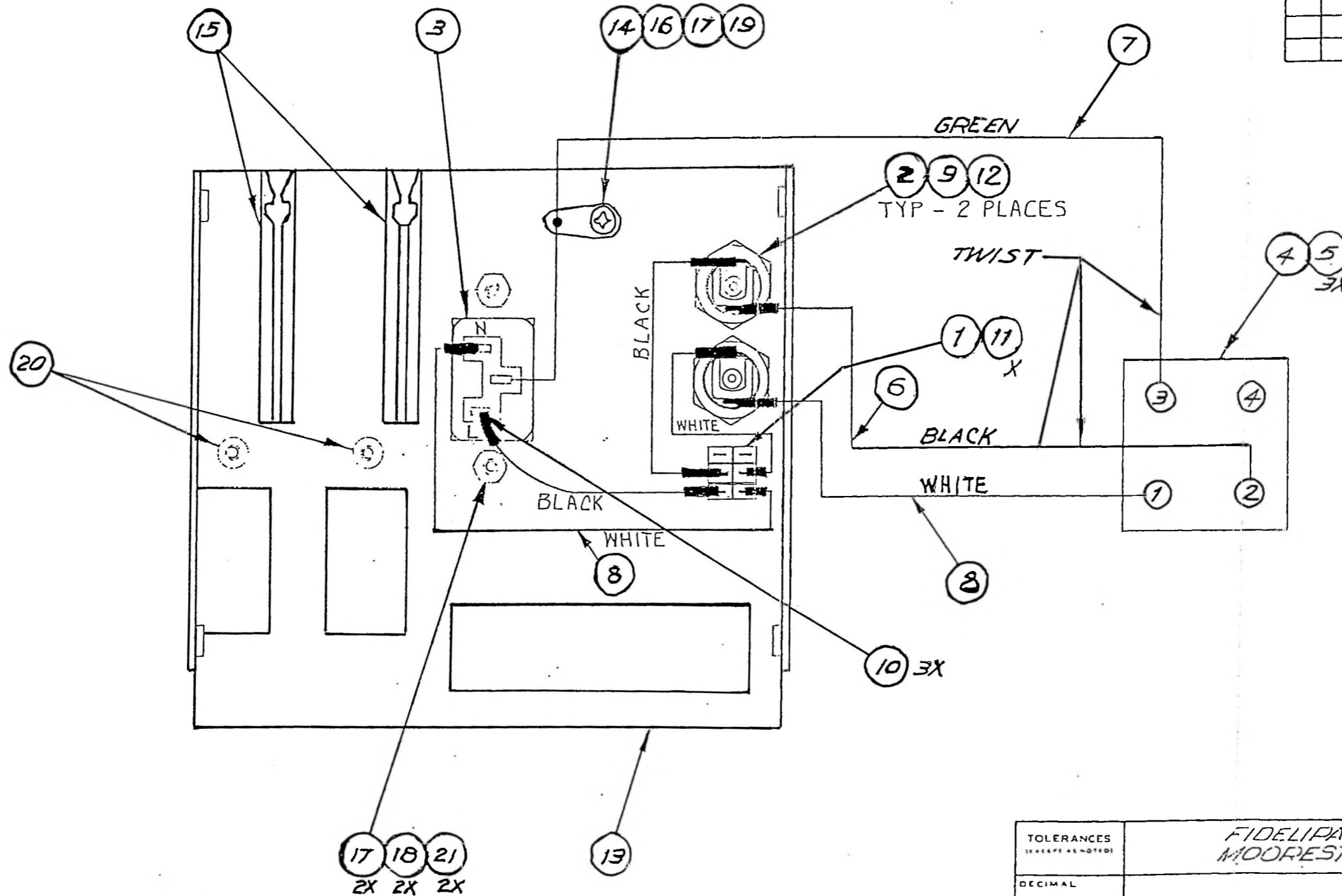

NOTES:

- 1 - SILK SCREEN PER 770-A0-035 BEFORE ASSEMBLY.
- 2 - 240V. WIRING SHOWN.

TOLERANCES (EXCEPT AS NOTED)	FIDELIPAC CORP. MOORESTOWN, N.J.		
DECIMAL	SCALE	DRAWN BY: <i>D. Panchal</i>	
± ~	~	APPROVED BY	
FRACTIONAL	TITLE <b>REAR PANEL ASM - CTR10</b>		
± ~	DATE	DRAWING NUMBER	
ANGULAR	5/31/88	<b>827-A0-068</b>	
± ~			

TRANSFORMER ASSEMBLY, TORROID for CTR10

FOR PARENT ITEM NUMBER 827-B0-023  
(REVISED 1/20/99)

PART NUMBER	DESCRIPTION	QTY	SEQ	Descriptor
311-B0-404	TORROID TRANSFORMER	1	1	
414-A0-007	TERMINAL, MR	7	2	JP2
414-A0-014	TERMINAL, M 1PSN 18-26GA	3	3	JP1
415-A0-015	HOUSING, 12 PIN MR	1	6	J2
415-A0-020	4 PIN CONNECTOR	1	7	J1
423-A1-89N	STRANDED WIRE 18 GA,WHITE	0	8	

(Previous number for transformer 827-B0-023)

Delivered-To: bmishkind@mail-tcsn.uswest.net  
Date: Thu, 12 Oct 2000 12:30:44 +0100  
From: "Steven Applegate" <steve@darenelectronics.co.uk>  
To: "Barry Mishkind" <bmishkind@uswest.net>  
Subject: Re: Daren Transformers  
X-Mailer: Microsoft Outlook Express 5.00.2615.200

Barry,

Daren part number 10000161.

Spec as follows. Split Primary for 120/230/240Vac input

Prmy: 0	-	100	-	120V
Brown				White
Black		Yellow		Blue

Copper screen is fitted.

Secdry: 2 x 24V O/P.

Connect in series for 48V O/P. Connect (Orange/White to red). The output is then taken from Orange and Red/White.

Connect in parralell for 24V O/P. Connect (Orange to red) and connect (Orange/White to Red/White). The output is then taken from these combined connections.

The Transformer is 100VA. Therefore at 24V single O/P max current is 4.16A  
OR 48V O/P 2.08A.

Hope this helps,  
Regards,

Steven Applegate.

Aug-08-00 03:17P

P.01

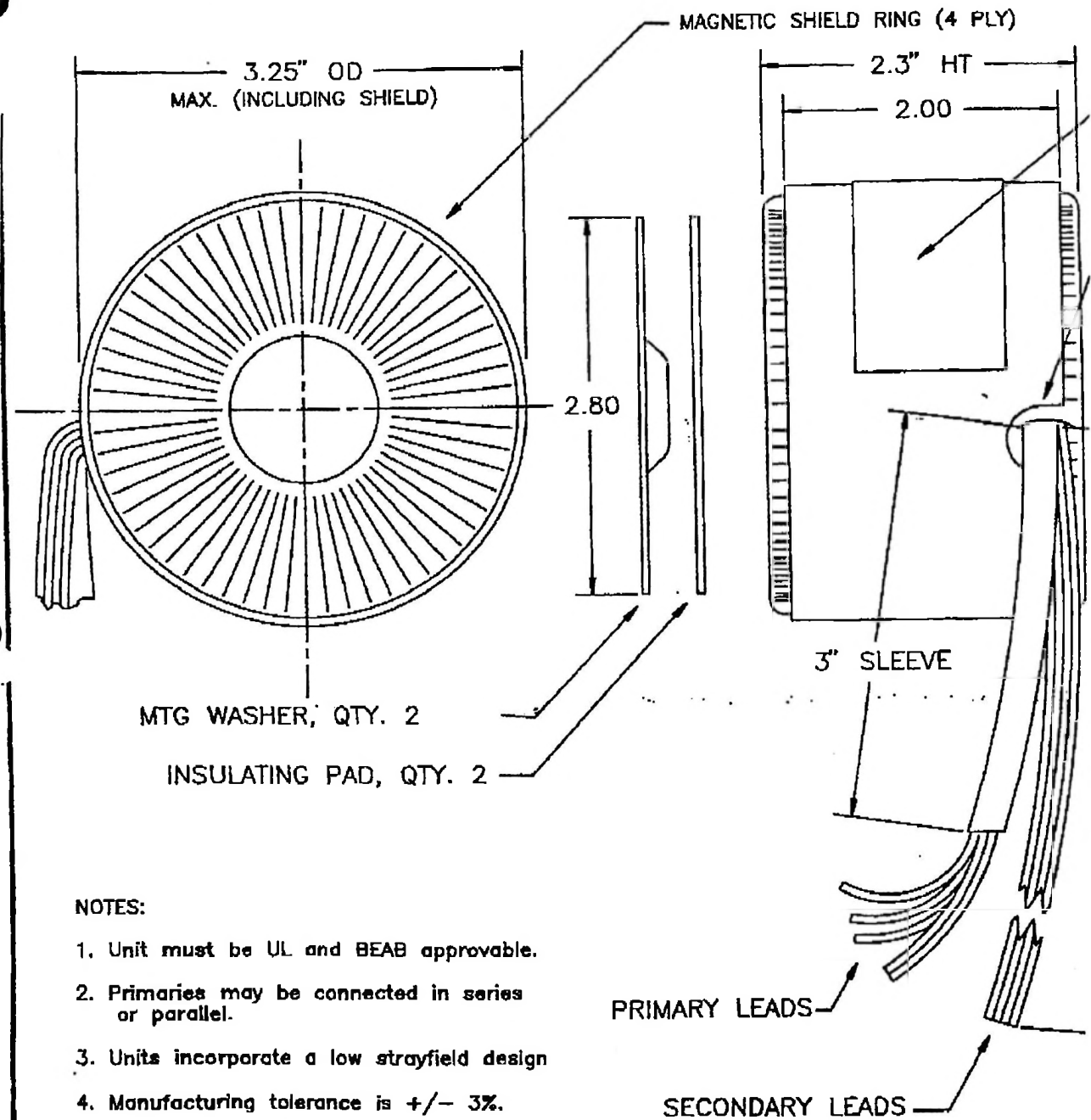

NOTES:

1. Unit must be UL and BEAB approvable.
2. Primaries may be connected in series or parallel.
3. Units incorporate a low strayfield design
4. Manufacturing tolerance is +/- 3%.
5. Exact primary currents, no-load loss, no-load current, and full load efficiency to be documented by vendor.

MATERIAL:

FINISH:

NEXT ASSY.

US 0

Aug-08-00 03:17P

P.02

REVISIONS			
REV	DESCRIPTION	DATE	APPROVED

G'S LABEL WITH FIDELIPAC PART NO.

CUT OUT FOR WIRE EXIT

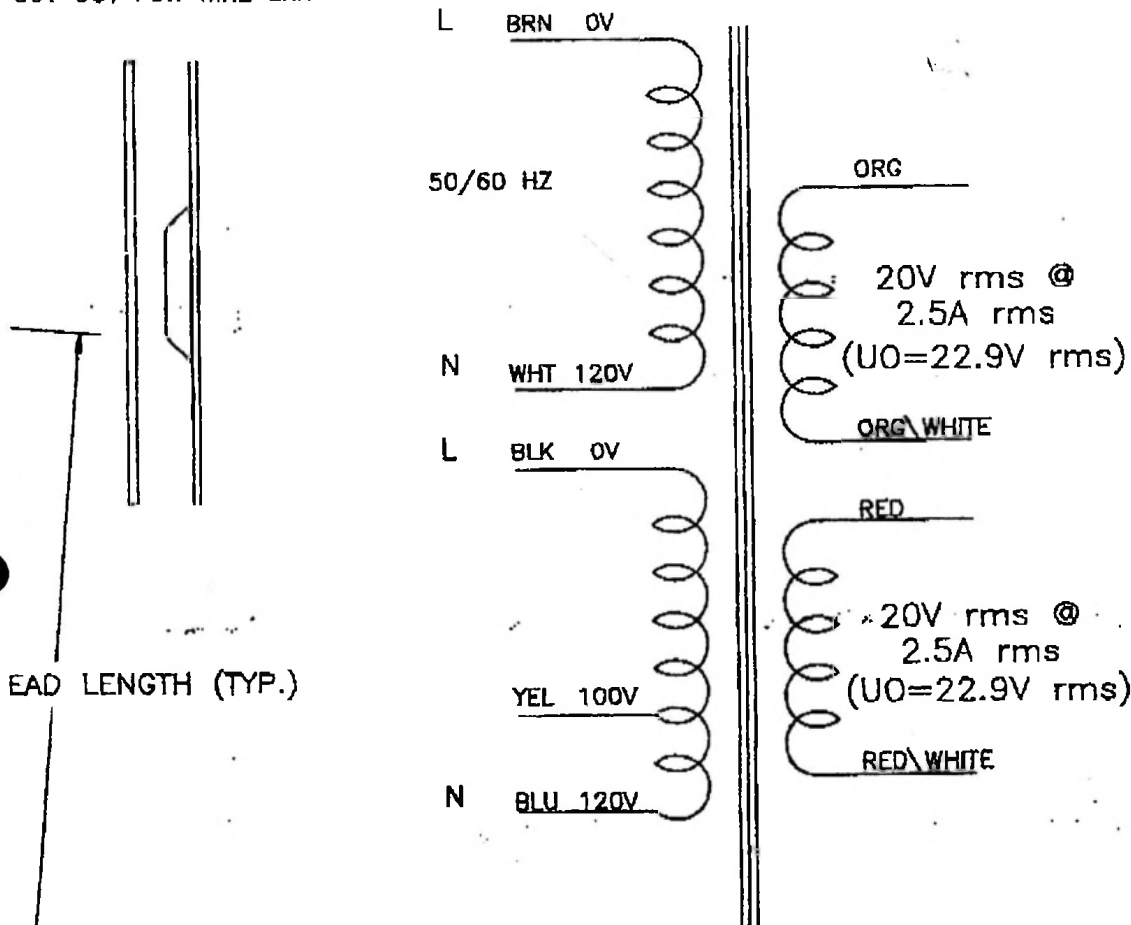

QTY REQD	QTY REQD	QTY REQD	DRAWING NO.	DESCRIPTION

PARTS LIST

REMOVE ALL BURRS  
BREAK SHARP EDGES  
.015 ± .010

UNLESS OTHERWISE SPECIFIED  
THE SURFACE FINISH OF  
MACHINED PART SHALL  
NOT EXCEED  MAX.

UNLESS OTHERWISE SPECIFIED  
DIMENSIONS ARE IN INCHES AND  
INCLUDE TOLERANCES OF FINISH

TOLERANCES OR		
SIZE	1 PLACE DECIMAL	2 PLACE DECIMAL
UP TO 6	±.02	±.005
ABOVE 6 TO 24	±.03	±.010
ABOVE 24	±.04	±.015
ANGULAR DIM. & 1/2"		

CONTRACT NO.

DRAWN BY T.J.W. DATE 6/18/91  
CHECKED BY

APPROVED BY M.H. 6/18/91

**FIDELIPAC CORP.**  
MOORESTOWN, N.J.

**TOROID POWER TRANSFORMER**  
100/120/220/240V

SIZE A	CODE	IDENT NO.	DWG. NO. 311-A0-404	REV
SCALE 1:1	SHEET 1 of 1			

311A0404

I N D E N T E D   B I L L   O F   M A T E R I A L S  
FOR PARENT ITEM NUMBER 827-BO-023                      TRANSFORMER ASM, CTR10

ITEM NUMBER	DESCRIPTION	QTY	SEQ
311-AO-006	TRANSFORMER - CTR 10	1	1
415-AO-015	HOUSING, 12 PIN MR	1	2
414-AO-007	TERMINAL, MR	12	3
423-A2-20N	WIRE STRANDED 22 AWG BLACK	2	4
5B2-AO-015	SPACER TRANSFORMER	4	5

415-AO-020 - 4 pin Male  
Housing

414-AO-014 Male Pin

DAREN TRANSFORMER 1000161

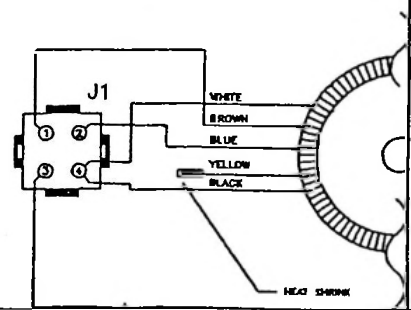
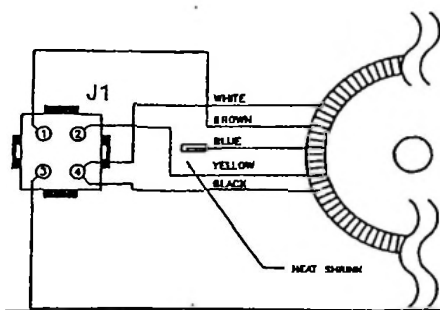
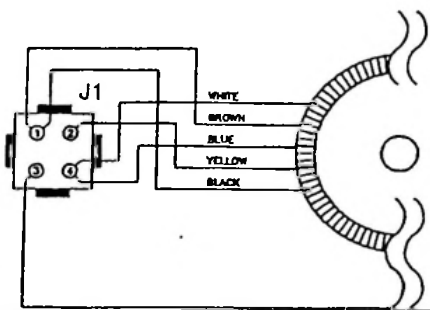
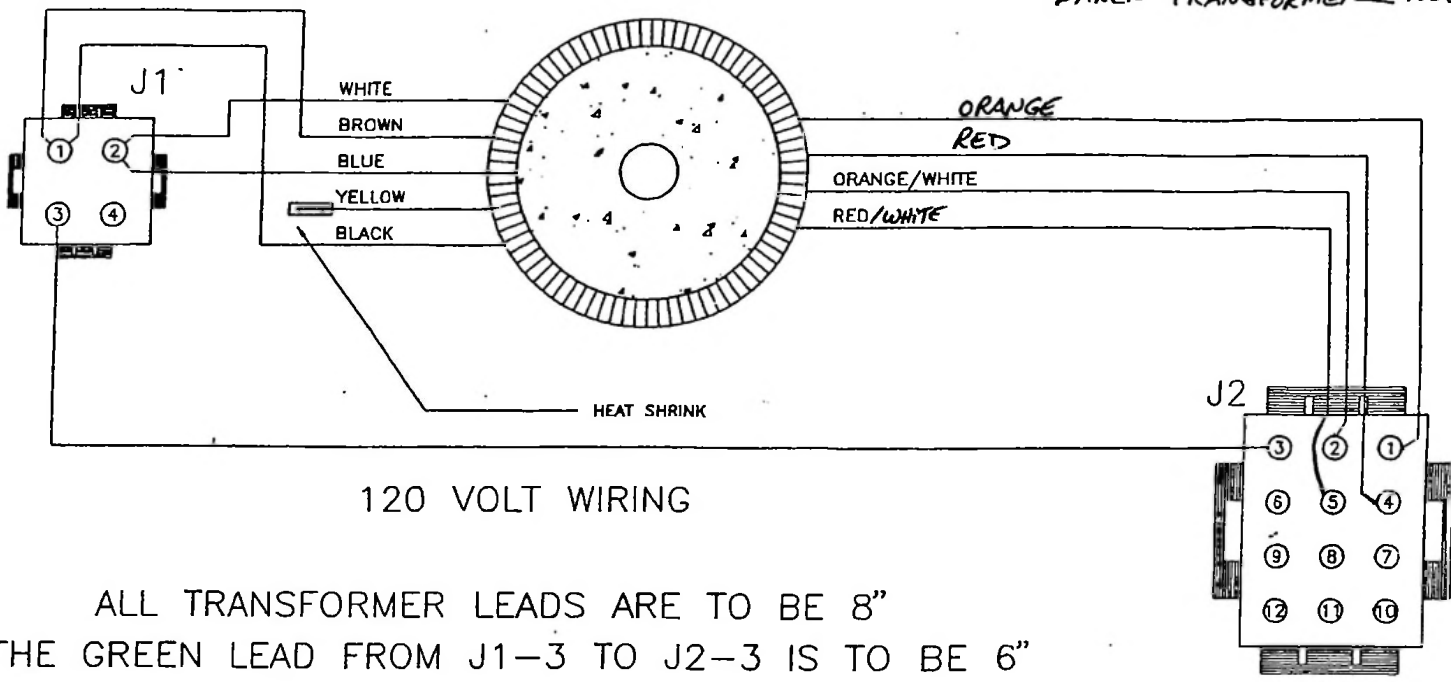

www.cartguy.com

MODEL NOS	SCHMATIC	827-00-023	APPR.	REVISION LEVELS	FIDELIPAC CORP. 1100 S. GARDNER ST. MOUNTAIN VIEW, CA 94039	THIS DOCUMENT IS OF FIDELIPAC CORP. REPRODUCTION OF ANY PART HERE OF
DC TO TOROID TRANSFORMER ASSEMBLY	SHEET 1 OF 1	ISSUE DATE 11/22/92	SCHMATIC	P.C. BOARD		

12/9/00



SEDLBAUER TRANSFORMER 852257

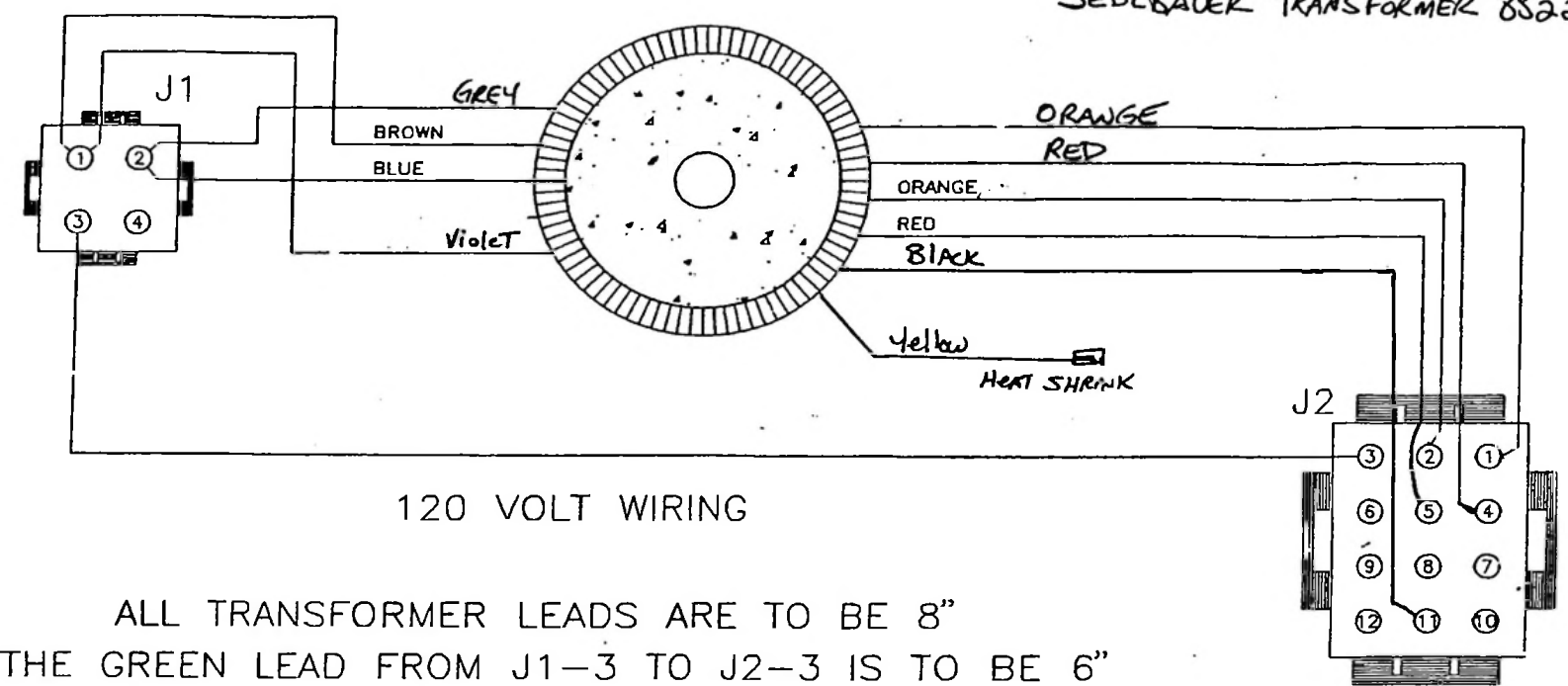

ALL TRANSFORMER LEADS ARE TO BE 8"  
 THE GREEN LEAD FROM J1-3 TO J2-3 IS TO BE 6"

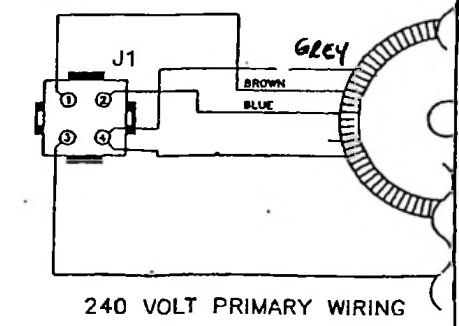

105.	SCHEMATIC	DWG. NO.	827-D0-023	APPR.		REVISION LEVELS		FIDELIPAC CORP. MOORESTOWN, N.J.	THIS DOCUMENT IS THE PROPERTY OF FIDELIPAC CORP. NO REPRODUCTION OF THIS DOCUMENT IS TO BE MADE WITHOUT PRIOR WR ITEN
		DC10 TORIOD TRANSFORMER ASSEMBLY		SHEET	1 OF 1	ISSUE DATE	11/22/92		

526-0023-004 DELTA

**PART INSPECTION CARD**

**SAMPLE CODE LEGEND**

Vendor: Sedlbauer  
 Part #: 81-8000-3799-6 Rev. \_\_\_\_\_  
 Description: Transformer Shielded Toroid

Yellow: \_\_\_\_\_  
 Orange: \_\_\_\_\_  
 Red: \_\_\_\_\_  
 Green: \_\_\_\_\_

Record new shipments only! No reworks, returns sorts, etc.

T1, T2 and B items are not eligible for skip-lot.

Refer to manual if revision changes.

0V braun 1  
 Einzelteilen 30lg  
 120V grau 2

Zwisol

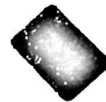

0V via 3  
 Einzelteilen 30lg  
 120V blau 2

23 or  
 24 schw  
 25 or  
 26 rot  
 27 gelb  
 28 rot

Zwisol

10.5V/1.80A U0=11.5V

0V Sammelteille 20lg

10.5V/1.80A U0=11.5V

19.0V/0.53A U0=21.3V

0V Sammelteille 20lg

19.0V/0.53A U0=21.3V

11,15 - 11,84

22,5 - 23,64

20,66 - 21,43

OK-D-R-S

Silver CAW

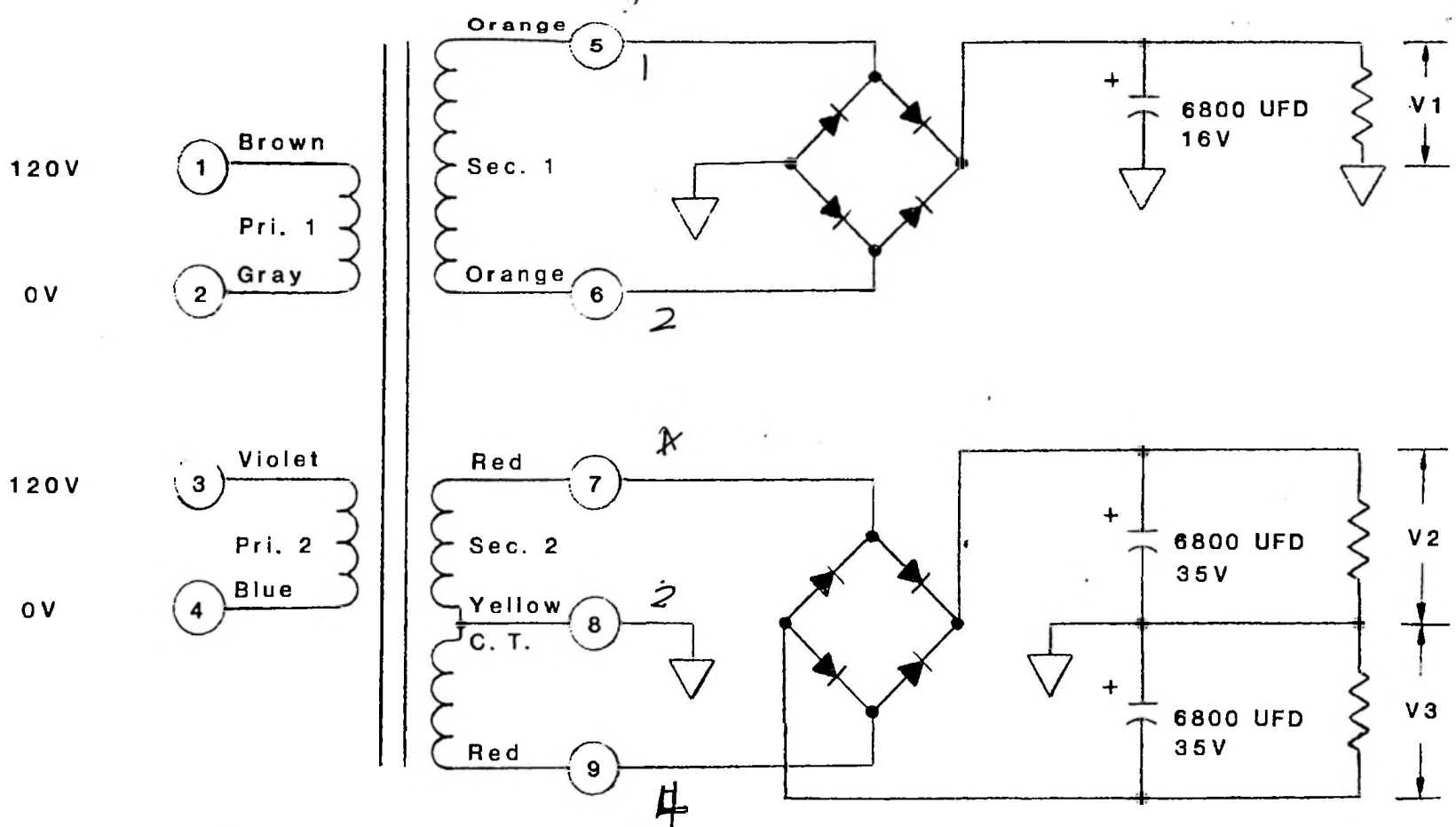

*Blue Body*

DC voltages and currents at 25 degree C			
	V1	V2	V3
Minimum load	+13.5V Max. at 0.1A	+26.0V Max. at 0.1A	-26.0V Max. at 0.1A
Maximum load	+9.0V Min. at 1.3A	+20.5V Min. at 1.0A	-20.5V Min. at 1.5A

Primaries connected for 120V or 240V, 50/60 Hz.

526-0022

SI-Proc-3798-8

3798-8

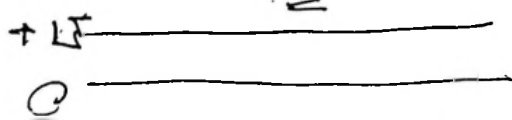
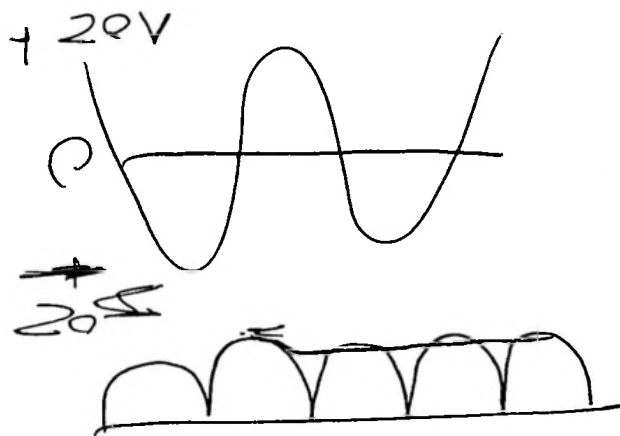
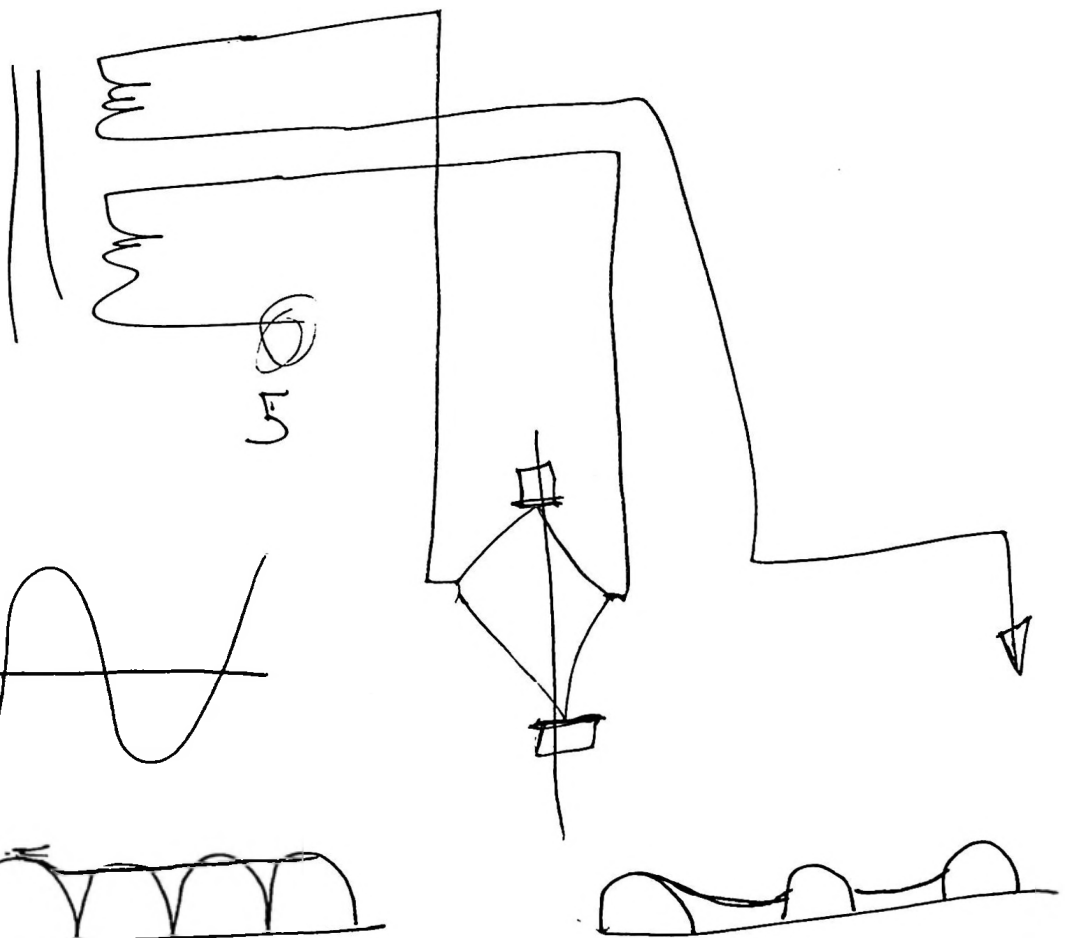
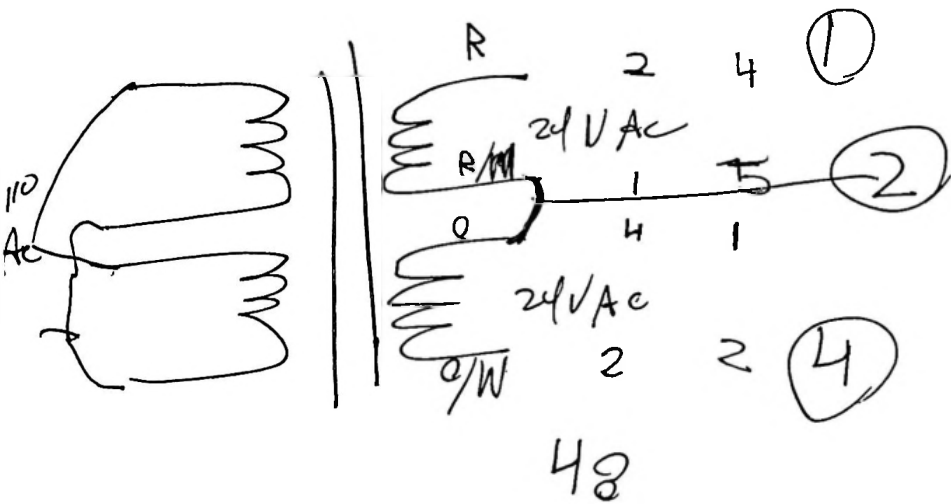

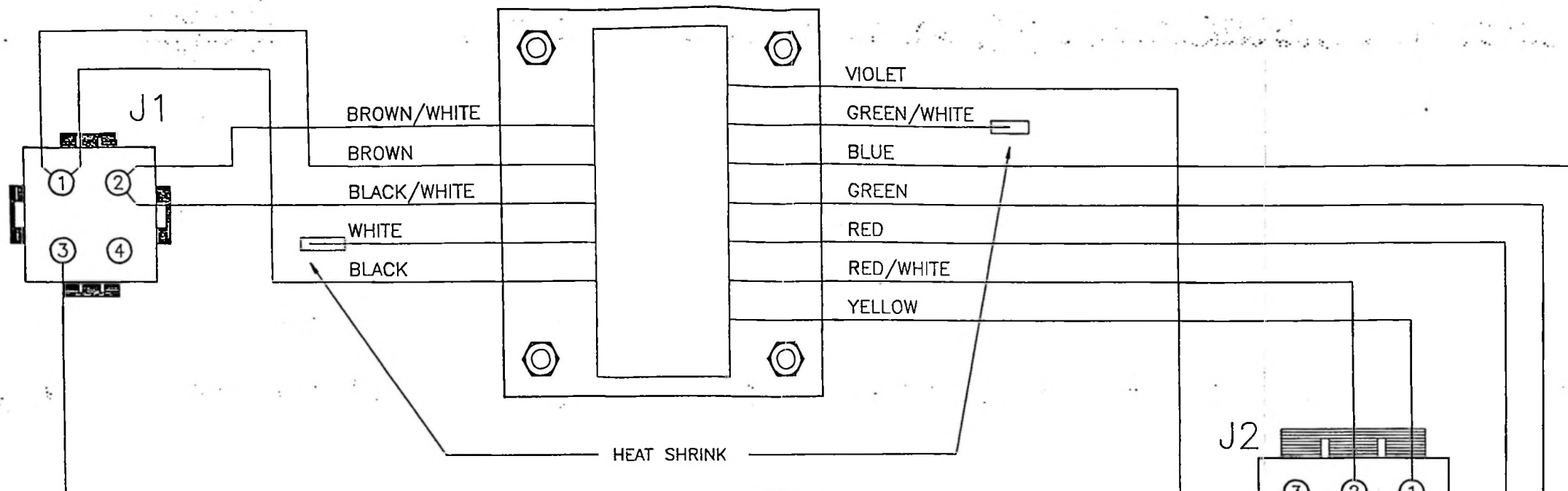

120 VOLT WIRING

ALL TRANSFORMER LEADS ARE TO BE 8"  
 THE GREEN LEAD FROM J1-3 TO J2-3 IS TO BE 6"

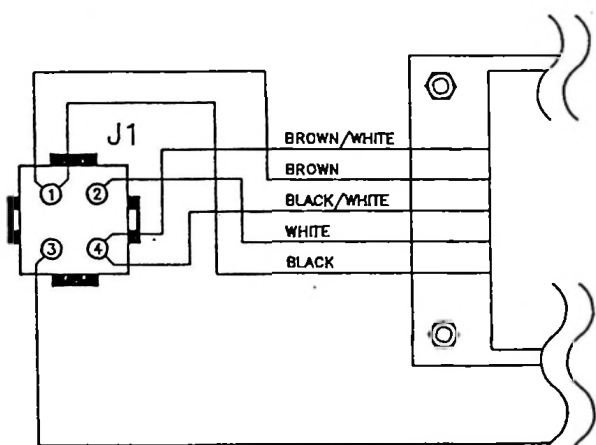
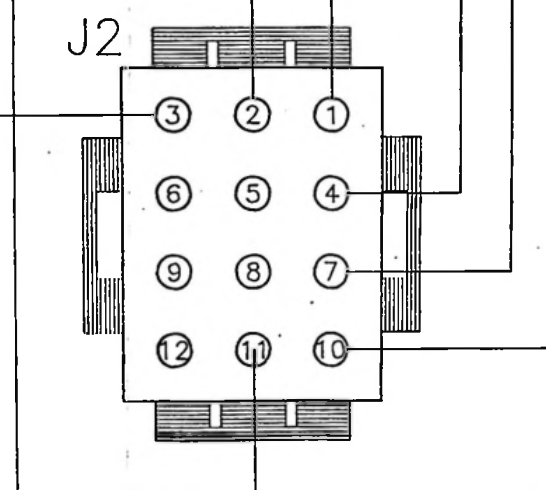

100 VOLT PRIMARY WIRING

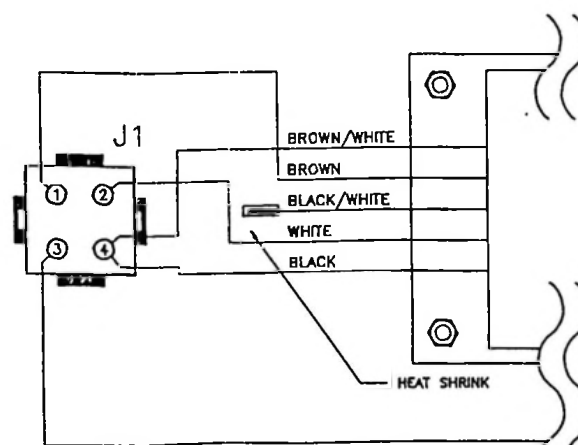

220 VOLT PRIMARY WIRING

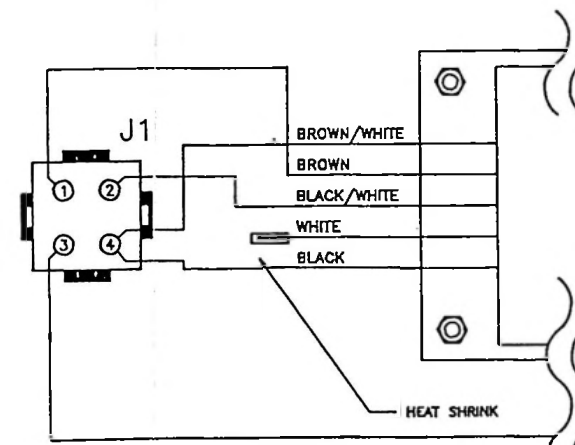

240 VOLT PRIMARY WIRING

MODEL NOS.	SCHEMATIC		DWG. NO.	APPR.	REVISION LEVELS		FIDELIPAC CORP. MOORESTOWN, N.J.	THIS DOCUMENT CONTAINS PROPRIETARY INFORMATION OF FIDELIPAC CORPORATION. NO USE, DISCLOSURE OR REPRODUCTION OF ANY PART THEREOF MAY BE MADE WITHOUT PRIOR WRITTEN PERMISSION.
	DC10 TRANSFORMER ASSEMBLY		827-CO-023		BILL OF MAT. XX			
	SHEET	1	OF	1	ISSUE DATE	2/18/92	SCHEMATIC XX	P.C.BOARD XX

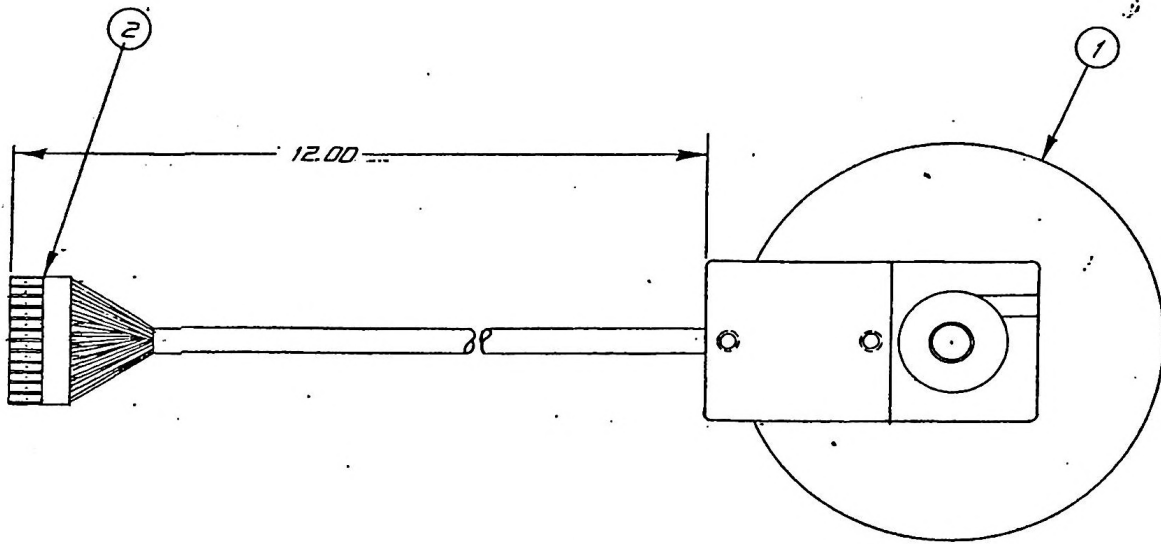

TOLERANCES (EXCEPT AS NOTED)		FIDELIFAC CORP MIDDESTOWN, N.J.	
DECIMAL		SCALE	DRAWN BY
±		FULL	APPROVED BY
FRACTIONAL		TITLE	
±		MOTOR ASSEMBLY	
ANGULAR		DATE	DRAWING NUMBER
±		26 JULY 92	827-A0-409

827-A0-022 MADE IN U.S.A.

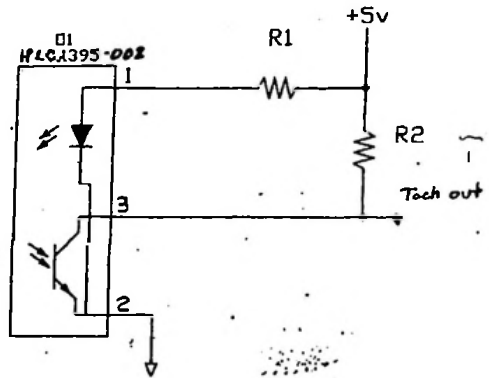

REVISIONS			
REV	DESCRIPTION	DATE	APPROVED
C	REDESIGNED CONVERTED FROM ANALOG TO DIGITAL	6/18/91	
D	ADDED R5, R6 & R7	9/18/91	

QTY REQD	QTY REQD	QTY REQD	DRAWING NO.	DESCRIPTION

PARTS LIST

MATERIAL:		REMOVE ALL BURRS BREAK SHARP EDGES .015 ± .010		UNLESS OTHERWISE SPECIFIED DIMENSIONS ARE IN INCHES AND INCLUDE DECIMALS OF PLACES TOLERANCES ARE		CONTRACT NO.		FIDELIPAC CORP. MOORESTOWN, N.J.	
FINISH:		NEXT ASSY.	USED ON	UP TO #	PLACES	PLACES	ORIGIN BY	DATE	SCH. CODE IDENT. NO.
				1.00	± .008	± .010	CHECKED BY		750-00 420
				1.00	± .010	± .015	APPROVED BY		SCALE
				1.00	± .015	± .020			SHEET 1 OF 1

750-00 420

MOTOR ASSEMBLY, DC for CTR10

FOR PARENT ITEM NUMBER 827-C0-409  
(REVISED 1/20/99)

PART NUMBER	DESCRIPTION	QTY	SEQ
323-C0-430	DC MOTOR, CLIFTON	1	1
807-F0-420	TACH ASSEMBLY	1	2
110-22-332	3.3K 1/4 W 5% CF Resistor	1	3
2010001	STANDOFF PEM KFE440-8	4	4
272-A0-402	OPTO SENSOR, SFH 900-2	1	5
3910022	150 ohm 1/4 W 1% MF Resistor	1	6
407-E0-420	TACH PCB	1	7
414-A0-013	CONNECTOR, BUTT SPLICE	3	8
423-A2-21N	STRANDED WIRE 22 AWG BROWN	1	9
423-A2-22N	STRANDED WIRE 22 AWG RED	1	10
423-A2-23N	STRANDED WIRE 22 AWG ORANGE	1	11
5A8-A0-000	RUBBER GROMMET	1	12
5E2-A0-402	PENETRATION SPRING	4	13
621-03-440	SCREW, PH 4-40 X 3/16 PL	4	14



DATE	BY	REVISION	REC	AUTH	DR	C

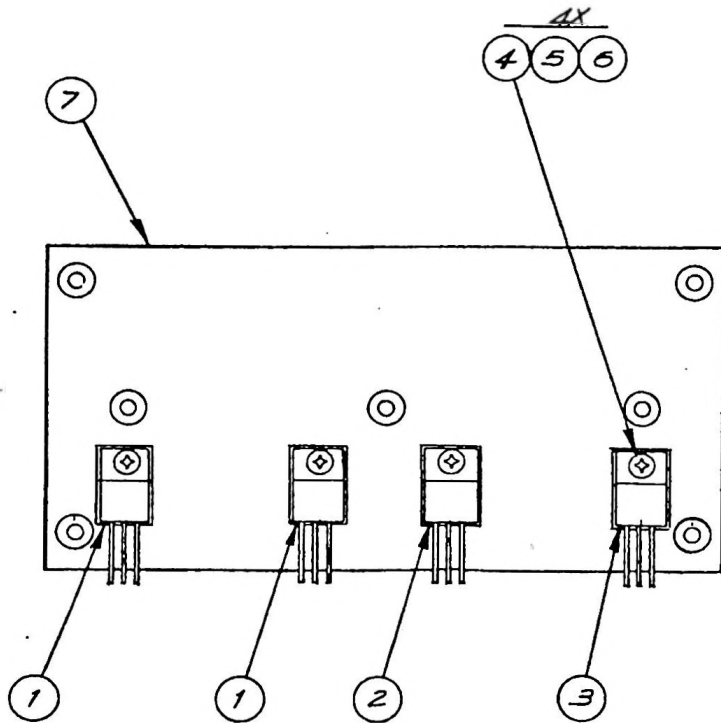

TOLERANCES (UNLESS OTHERWISE SPECIFIED)		FIDELIPAC CORP MOORESTOWN, N.J.	
DECIMAL	SCALE	DRAWN BY <i>[Signature]</i>	
2 ~	~	APPROVED BY	
FRACTIONAL	TITLE	HEAT SINK ASM CTR:0	
2 ~	DATE	DRAWING NUMBER	
ANGULAR	26 NOV 85	827-A0-021	
2 ~			

HEAT SINK ASSEMBLY for CTR10

FOR PARENT ITEM NUMBER 827-A0-021

PART NUMBER	DESCRIPTION	QTY	SEQ	Designation
230-A0-012	LM7815CT, +15 VOLT REGULATOR	2	1	
230-A0-014	LM7915CT, -15 VOLT REGULATOR	1	2	
230-A0-015	AN7918 IC, 18 VOLT REGULATOR	1	3	
440-A0-000	INSULATOR TO 220 SIL PAD	4	4	VR1-VR4
541-B0-033	HEAT SINK, MOTHER BOARD CTR10	1	7	
607-01-124	WASHER SHOULDER	4	5	VR1-VR4
621-03-440	SCREW P.H. PHIL 4-40 X 3/16 PL	4	6	VR1-VR4

DATE	SYM	REVISION RECORD	AUTH.	DR.	CK.

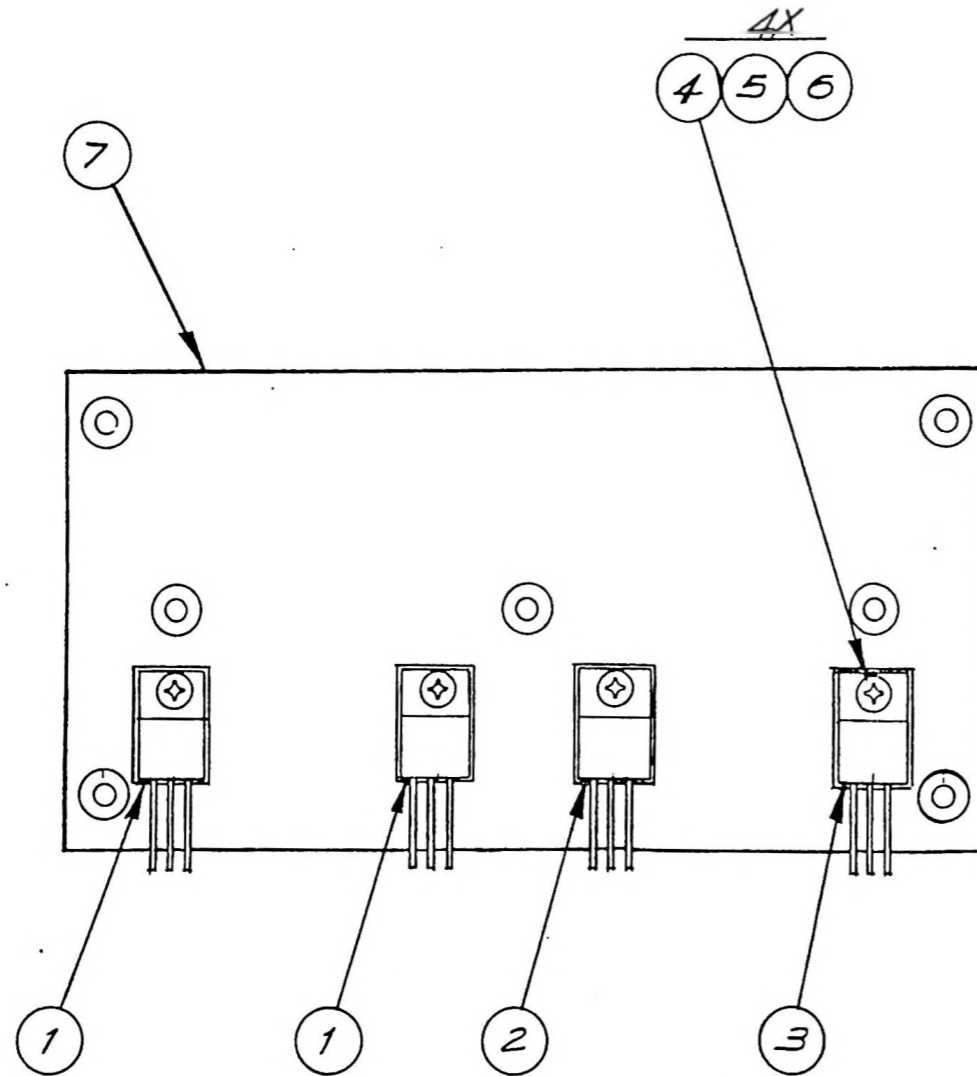

TOLERANCES (EXCEPT AS NOTED)	FIDELIPAC CORP MOORESTOWN, N.J.		
DECIMAL ± ~	SCALE ~	DRAWN BY <i>[Signature]</i>	
FRACTIONAL ± ~	TITLE HEAT SINK ASM CTR'0		
ANGULAR ± ~	DATE 26 NOV 85	DRAWING NUMBER 827-A0-021	
APPROVED BY			

DATE	BY	REVISION RECORD	AUTH	DR	CK

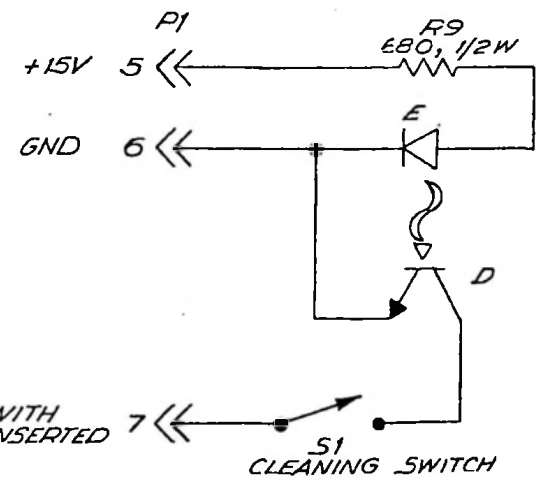
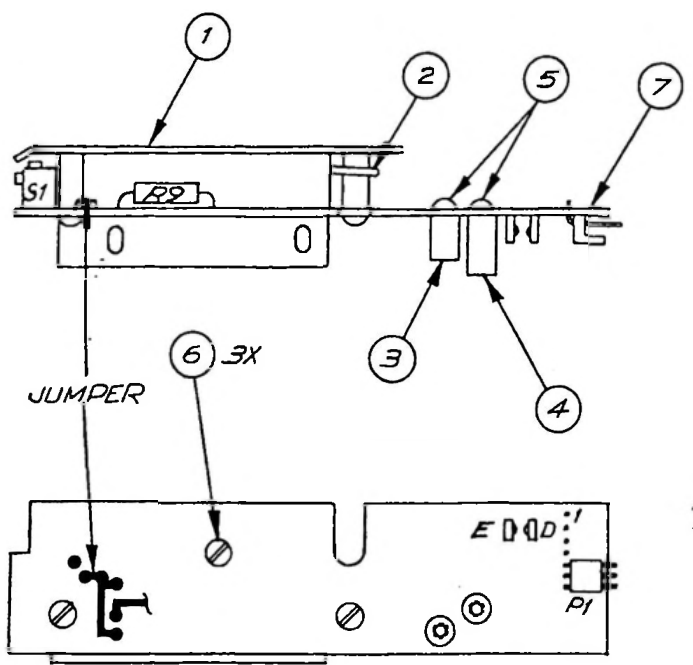

TOLERANCES (EXCEPT AS NOTED)		FIDELIPAC CORP MOORESTOWN, NJ	
DECIMAL	CTR:0/ESD 10	SCALE	DRAWN BY: <i>[Signature]</i>
2 ~		~	APPROVED BY:
FRACTIONAL	TITLE BRACKET ASM RIGHT		
2 ~			
ANGULAR	DATE	DRAWING NUMBER	
2 ~		827-A0-025	

DWA 807-A0-061 MADE IN U.S.A.

RIGHT BRACKET ASSEMBLY for CTR10

FOR PARENT ITEM NUMBER 827-A0-025

PART NUMBER	DESCRIPTION	QTY	SEQ
543-E0-007	RIGHT CART HOLD DOWN BRACKET	1	1
5AB-D0-003	HOLD DOWN SHAFT BEARING	2	8
5B2-A0-010	SPACER, 1/4 X 3/8 - #4 NYLON	1	3
5B2-A0-011	SPACER, 1/4 X 1/2 - RD #4 NYLON	1	4
5E2-A0-002	CART HOLD DOWN SPRING	1	2
687-03-440	SCREW RD SLOT 4-40 X 3/16 NYLON	2	5
687-08-440	SCREW RH SLOT 4-40 X 1/2 NYLON	3	6
807-A0-061	CART READY PWA	1	7
703-A0-000	TEFLON TAPE, 1" WIDE	0	0

DATE	SYM	REVISION RECORD	AUTH	DR.	CK.

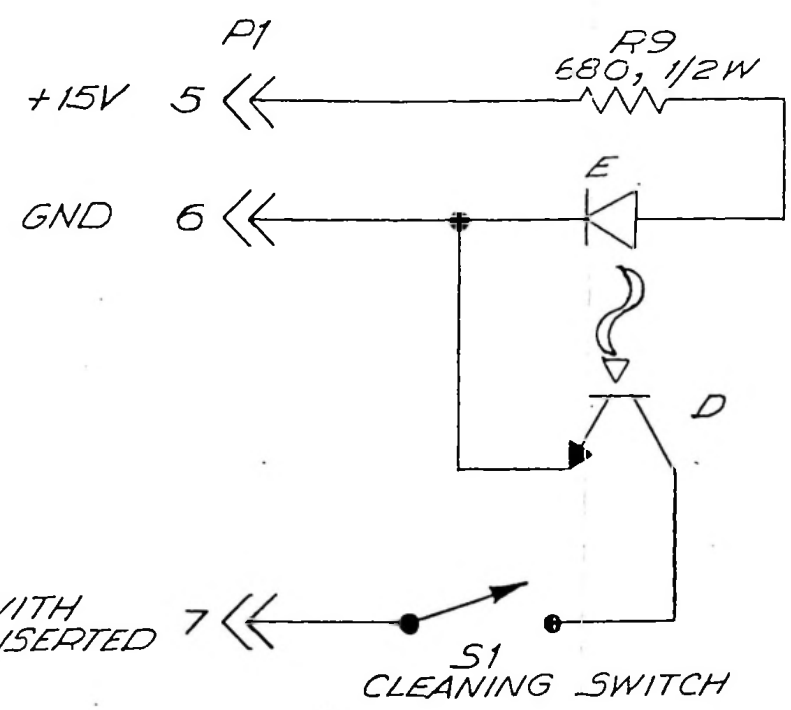
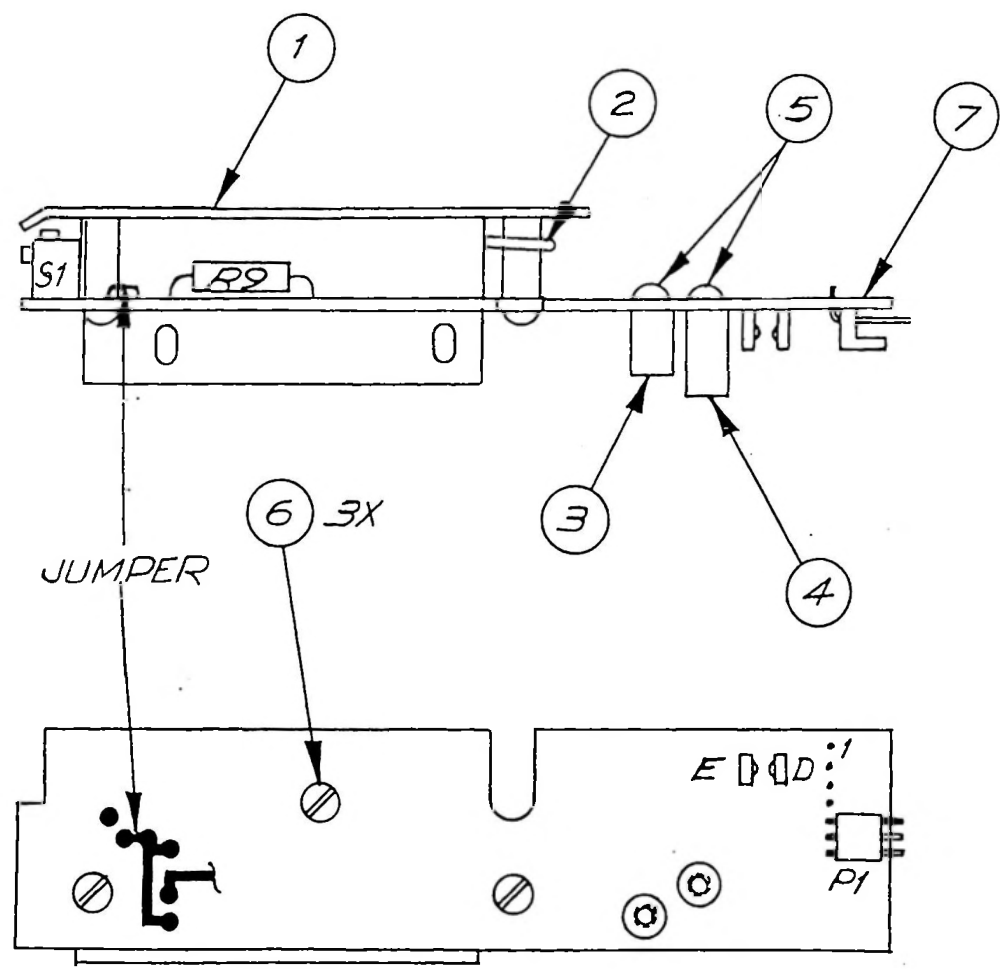

TOLERANCES (EXCEPT AS NOTED)	FIDELIPAC CORP MOORESTOWN, NJ		
DECIMAL ± ~	CTR10/ESD 10	SCALE ~	DRAWN BY APPROVED BY
FRACTIONAL ± ~	TITLE BRACKET ASM RIGHT		
ANGULAR ± ~	DATE	DRAWING NUMBER 827-A0-025	

DECK ASSEMBLY for CTR10

FOR PARENT ITEM NUMBER 827-A0-026

PART NUMBER	DESCRIPTION	QTY	SEQ
320-A0-000	SOLENOID	1	13
415-A0-011	HOUSING MTA 100 2 COND	1	44
526-A0-000	SOLENOID Stud	1	14
531-D0-002	DECK PLATE CTR 10	1	1
543-B0-011	STOP Actuator	1	48
543-D0-008	CART Actuator	1	43
5A0-A0-000	CHAIN, SPROCKET .1475 PITCH ST	1	11
5A1-A0-001	SOLENOID FOOT, STOP	1	42
5A3-A0-000	CART HOLD DOWN ROLLER,	4	23
5AA-B0-002	SOLENOID Sprocket	1	9
5AB-D0-003	HOLD DOWN BEARING, SHAFT	2	26
5B3-A0-001	RETAINER RING 3/16 SHAFT	4	8
5B4-A0-000	HEADED SPIRAL PIN 1/16 X $\frac{3}{4}$	1	10
5B8-A0-003	CART HOLD DOWN FRONT SHAFT A	1	24
5B8-B0-001	VERTICAL BALL BEARING SHAFT	1	5
5B8-E0-002	HORIZONTAL SHAFT	1	4
5E1-A0-002	SOLENOID SPRING EXTENSION	1	39
5E1-B0-001	SPRING EXTENSION SWITCH	1	38
5E2-A0-002	CART HOLD DOWN SPRING,	1	25
600-20-032	SOLENOID HEX NUT, 10-32 STL PL	1	15
601-07-000	WASHER .31 X .191 X .025 SS	4	41
601-07-001	WASHER .53 X .13 X .05 SS	1	46
601-07-002	WASHER .50 X .252 X .01 SS	2	40
60C-11-000	LOCK WASHER I.T. #10		3 16
60C-11-200	LOCK WASHER I.T. #2		1 36
60C-11-600	LOCK WASHER I.T. #6		3 7
621-03-256	SCREW P.H. PHIL 2-56 X 3/16 ZP	1	35
621-03-440	SCREW P.H.- PHIL 4-40 X 3/16 PL	1	0
621-04-440	SCREW P.H. PHIL 4-40 X 1/4 SP	2	37
621-05-440	SCREW P.H. PHIL 4-40 X 5/16 PL	1	49
621-05-632	SCREW P.H. PHIL 6-32 X 5/16 PL	2	21
621-06-632	SCREW P.H. PHIL 6-32 X 3/8 ZP	1	22
621-08-032	SCREW P.H. PHIL 10-32 X .5 SP	2	19
700-A0-001	GLUE, EASTMAN 910 OR EQUIV.	1	45
827-A0-025	RIGHT BRACKET ASM CTR10	1	17
827-A0-063	LEFT BRKT ASM "A"	1	18
827-A0-065	ACTUATOR/"A" REAR SHAFT ASM	1	34

DATE	BY	REVISION RECORD	AUTH	DR	CR
8/24	C				

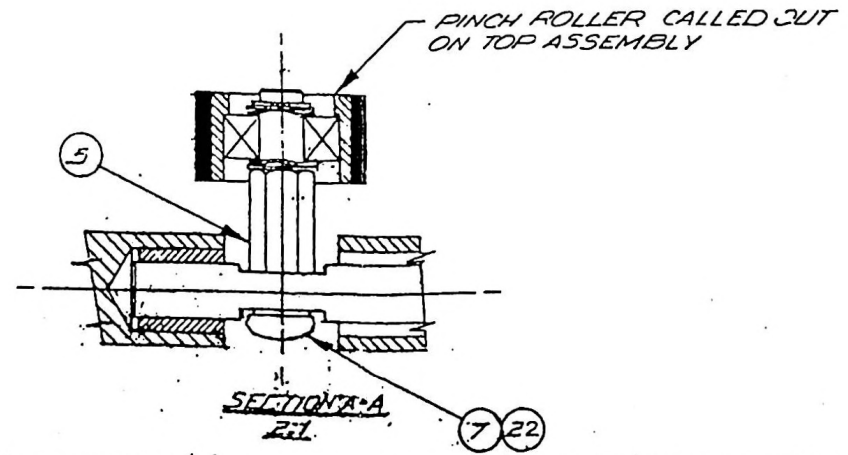
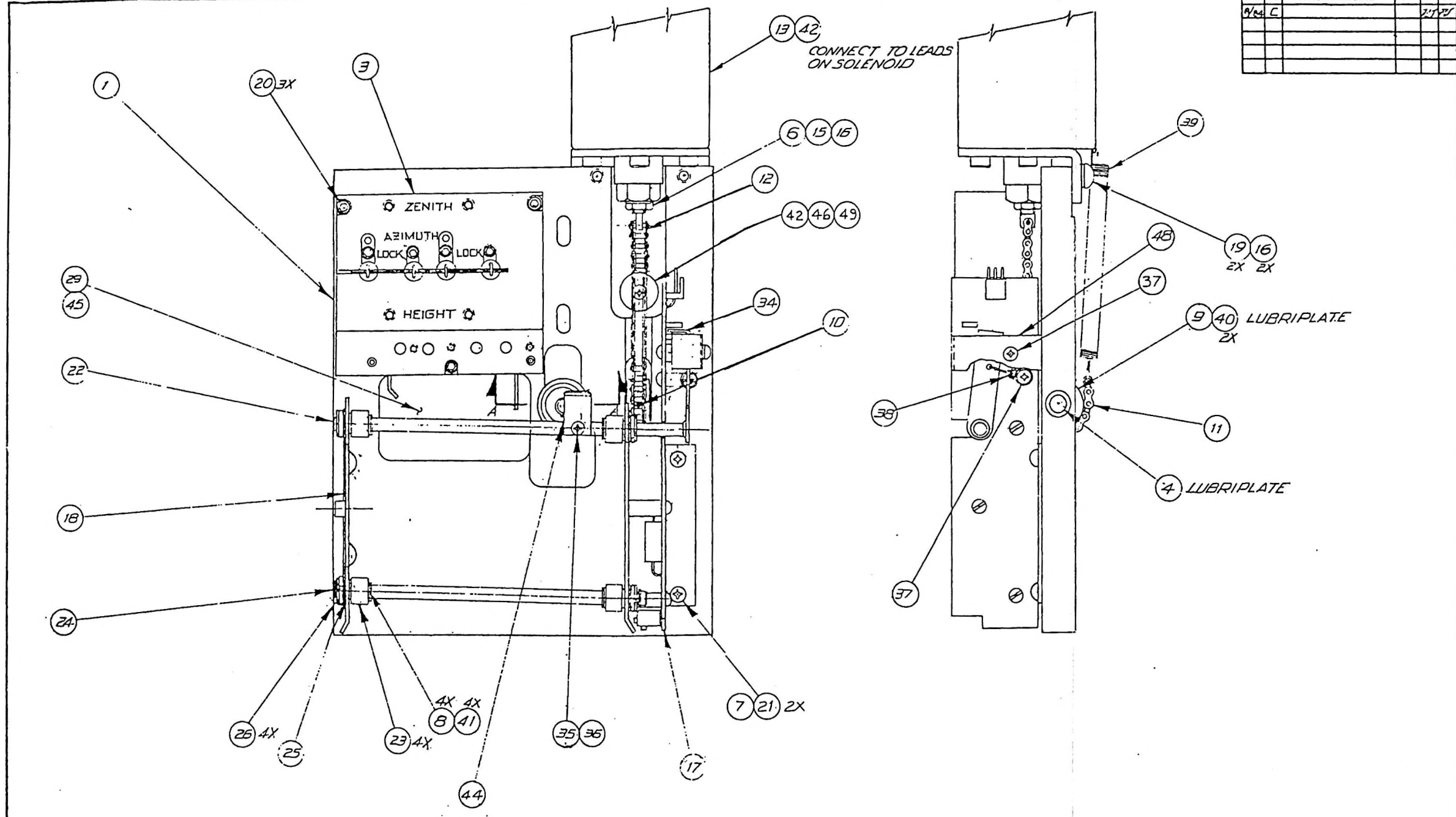

TOLERANCES UNLESS OTHERWISE SPECIFIED	FIDELIFAC CORP MOORESTOWN, N.J.		
DECIMAL		SCALE	DRAWN BY <i>2</i>
FRACTIONAL			APPROVED BY
ANGULAR	DATE	DRAWING NUMBER	
	1 AUG 84	827-AD-026	





CART READY PWA for CTR10

FOR PARENT ITEM NUMBER 827-A0-061

PART NUMBER	DESCRIPTION	QTY	SEQ	Designation
110-32-681	680 OHM 1/2 W 5% CF Resistor	1	1	R9
271-A0-001	OP550 PHOTO Transistor	1	2	D
271-A0-002	IR EMITTING Diode	1	3	E
361-A0-000	SLIDE SWITCH , SPDT	1	4	S1
407-D0-060	CART SCAN PCB	1	5	
416-A0-019	HEADER, 3 POSITION RT	1	6	P1
420-A0-001	WIRE, BUS 22 AWG	1	7	

REVISIONS			
LTR	DESCRIPTION	DATE	APPROVED
B	ADD R82 AND R83	1/1/64	[Signature]
D	REVISED PER ECN Q14	7/1/64	[Signature]
E	REVISED PER ECN Q25	7/30/64	[Signature]
F	REVISED PER ECN Q28	9/15/64	[Signature]

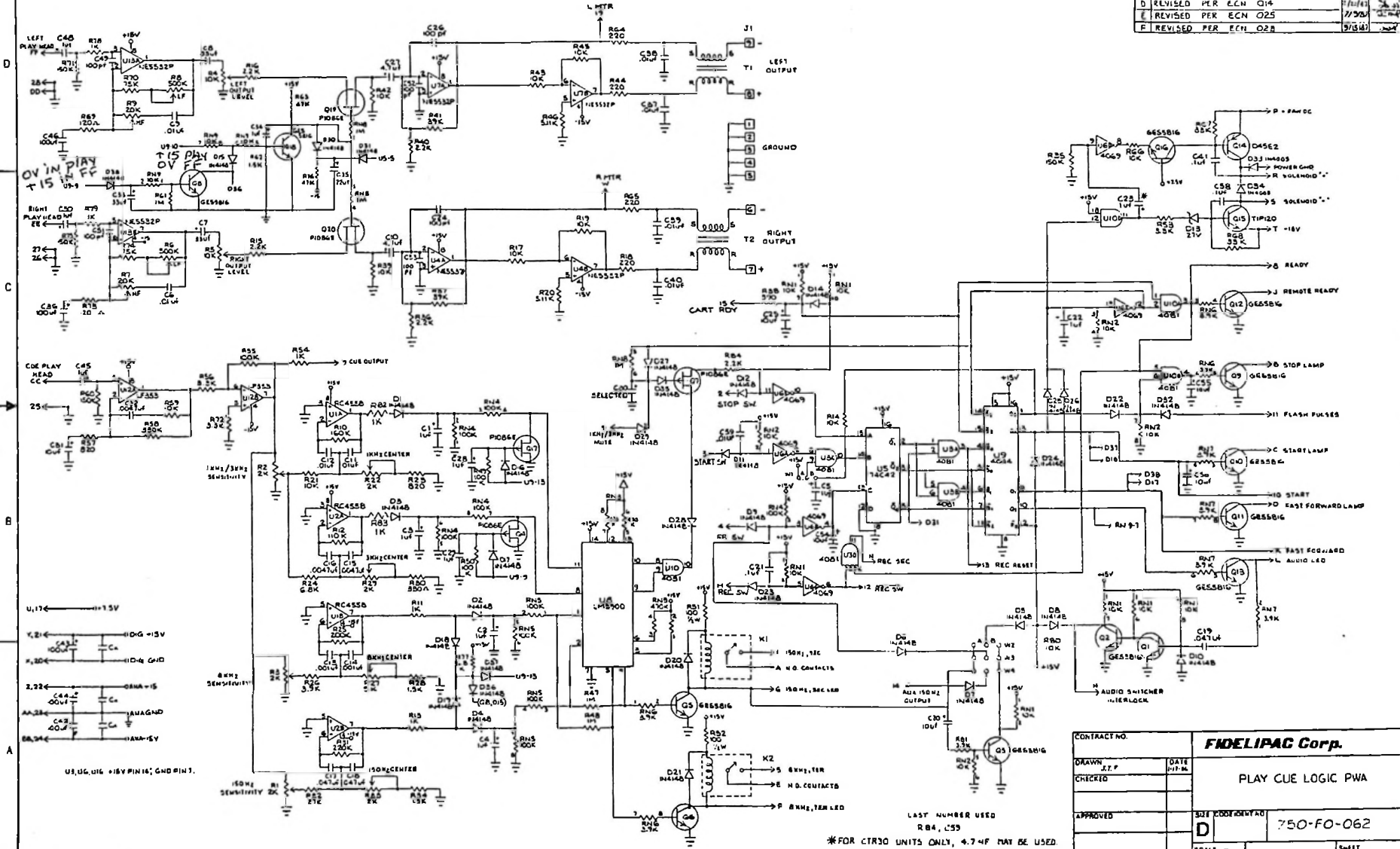

CONTRACT NO.		<b>FIDELIPAC Corp.</b>	
DRAWN BY	DATE	<b>PLAY CUE LOGIC PWA</b>	
CHECKED	1/1/64		
APPROVED		SHEET IDENTIFIED	<b>750-FO-062</b>
		SCALE	SHEET

LAST NUMBER USED  
R84, C59  
\*FOR CTR30 UNITS ONLY, 4.74F MAY BE USED

PLAY/CUE/LOGIC PWA for CTR10

FOR PARENT ITEM NUMBER 827-E0-076

PART NUMBER	DESCRIPTION	QTY	SEQ	Designation
006-A6-103	.01 uF 25V D CAP	12	1	C37-40, 59
011-A5-105	1 uF 50V E CAP	12	2	C1-5,22,28,29,34,45,48,50
011-A5-106	10 uF 50V E CAP	7	3	C20, 25, 31, 54-57
011-A5-225	2.2 uF 50V E CAP	1	4	C23
011-A5-226	22 uF 50V E CAP	1	5	C35
011-A5-475	4.7 uF 50V E CAP	2	6	C10, 27
011-A5-685	6.8 uF 50V E CAP	1	7	C30
011-A8-107	100 uF 25V E CAP	5	8	C36, 42-44, 46
011-B5-336	33 uF 25V E CAP	3	9	C7, 8, 33
031-A3-101	100 PF S CAP	6	10	C24, 26, 49, 51, 52, 53
041-A3-102	.001 uF 63V 5 CAP	2	11	C13, 14
041-A3-103	.01 uF 63V 5 CAP	4	12	C6, 9, 11, 12
041-A4-104	.1 uF 63V F CAP	3	13	C21, 41, 58
041-A4-472	.0047 uF 63V F CAP	3	14	C15, 16, 32
041-A4-473	.047 uF 63V F CAP	3	15	C17, 18, 19
110-22-102	1K 1/4W 5% CF Resistor	7	17	R11, 13, 54, 78, 79, 82, 83
110-22-103	10K 1/4W 5% CF RCS	7	18	R14, 21, 39, 42, 59, 66, 80
110-22-104	100K 1/4W 5% CF Resistor	3	19	R49, 50, 55
110-22-105	1M 1/4W 5% CF Resistor	3	20	R47, 48, 61
110-22-114	110K 1/4W 5% CF Resistor	1	21	R12
110-22-121	120 OHM 1/4W 5% CF Resistor	2	22	R69, 73
110-22-152	1.5K 1/4W 5% CF Resistor	3	21	R28, 34, 62
110-22-154	150K 1/4W 5% CF Resistor	4	23	R35, 60, 71, 75
110-22-164	160K 1/4W 5% CF Resistor	1	24	R10
110-22-204	200K 1/4W 5% CF Resistor	1	25	R25
110-22-221	220 1/4W 5% CF Resistor	4	26	R18, 44, 64, 65
110-22-222	2.2K 1/4W 5% CF Resistor	5	27	R15, 16, 36, 40, 84
110-22-224	220K 1/4 W 5% CF Resistor	1	28	R31
110-22-273	27K 1/4W 5% CF Resistor	1	29	R32
110-22-331	330 OHM 1/4W 5% CF Resistor	1	30	R30
110-22-332	3.3K 1/4W 5% CF Resistor	3	31	R53, 56, 72
110-22-333	33K 1/4W 5% CF Resistor	2	32	R67, 68
110-22-334	330K 1/4W 5% CF Resistor	1	33	R58
110-22-391	390 1/4W 5% CF Resistor	1	34	R38
110-22-392	3.9K 1/4W 5% CF Resistor	2	35	R26, 81
110-22-393	39K 1/4W 5% CF Resistor	2	36	R37, 41
110-22-473	47K 1/4W 5% CF Resistor	2	37	R63, 76
110-22-682	6.8K 1/4W 5% CF Resistor	2	38	R24, 77
110-22-753	75K 1/4W 5% CF Resistor	2	39	R70, 74

PLAY/CUE/LOGIC PWA for CTR10 - PAGE 2  
FOR PARENT ITEM NUMBER 827-E0-076

PART NUMBER	DESCRIPTION	QTY	SEQ	Designation
110-22-821	820 1/4W 5% CF Resistor	2	40	R23, 57
110-32-101	100 1/2W 5% CF Resistor	2	41	R51, 52
120-20-10S	10K 1/4W 1% MF Resistor	4	42	R17, 19, 43, 45
120-20-51N	5.11K 1/4W 1% MF Resistor	2	43	R20, 46
13M-33-103	10K Vertical Trim	2	44	R4, 5
13M-33-202	2K Vertical Trim	3	45	R1, 2, 3
13M-33-203	20K Vertical Trim	2	46	R7, 9
13M-33-504	500K Vertical Trim	2	47	R6, 8
13T-33-202	2K Horizontal Trim	3	48	R22, 29, 33
13T-33-502	5K Horizontal Trim	1	49	R27
144-11-103	Resistor Net, 10K-4	2	50	RN2, 9
144-11-104	Resistor Net, 100K-4	2	51	RN4, 5
144-11-105	Resistor Net, 1M-4	1	52	RN8
114-11-392	Resistor Net, 3.9K-4	2	53	RN6, 7
114-11-474	Resistor Net, 470K-4	1	54	RN3
196-11-103	Resistor Net, 10K-9	1	55	RN1
200-A0-000	1N4148 Diode	34	56	D1-12, 14-28, 30-32, 35-8
201-A0-000	1N4005 Diode	2	57	D33, 34
204-A0-005	1N4750A 27 Volt Zener	1	58	D13
210-A0-002	MPS2222 Transistor	13	59	Q1-3, 5, 6, 8-13, 16, 18
211-A0-002	TIP120 NPN Transistor	1	60	Q15
211-A0-004	D45E2 Transistor	1	61	Q14
220-A0-000	P1086E P FET Transistor	5	62	Q4, 7, 17, 19, 20
230-A0-000	5532 DUAL OP-AMP IC	3	63	U4, 7, 13
230-A0-003	LM3900 IC	1	64	U8
230-A0-008	LF353 IC	1	65	U12
230-A0-010	RC4558 IC	2	66	U1, 2
231-A0-028	4081 IC	2	67	U3, 10
231-A0-030	4069 IC	1	68	U6
231-A0-033	74C42 IC	1	69	U5
231-A0-044	4044 IC	1	70	U9
300-A0-000	INDUCTOR BALUN	4	71	C1, C2, T1, T2
350-A0-000	RELAY B PDT 12V PC MOUNT	2	72	K1, 2
407-E0-075	PCB, PLAY/CUE/LOGIC	1	73	
410-A0-001	8 PIN DIP Socket	6	74	U1, 2, 4, 7, 12, 13
410-A0-002	14 PIN DIP Socket	4	75	U3, 6, 8, 10
410-A0-003	16 PIN DIP Socket	2	76	U5, 9
418-A0-004	9 PIN D RT ANGLE RECEPT	1	77	J1
416-A0-001	D CONN RT ANGLE HRDWR	1	78	J1
420-A0-001	WIRE BUS 22 AWG	1	79	W1A

PLAY/CUE/LOGIC PWA for CTR10 - PAGE 3  
FOR PARENT ITEM NUMBER 827-E0-076

PART NUMBER	DESCRIPTION	QTY	SEQ	Designation
423-A2-65N	WIRE STRANDED, 26 AWG GRN	1	80	
426-A0-001	WIRE, 2 COND W SHLD, 28 AWG	6	81	
44S-A0-000	SHRINK TUBING 3/16	1	82	
5AB-A0-007	BOARD EJECTOR	2	83	
601-20-440	HEX NUT 4-40 STEEL PLATE	2	84	J1
60C-11-400	LOCK WASHER I.T. #4	2	85	J1
621-05-440	SCR P.H. PHIL 4-40 X 5/16 PL	2	86	J1
837-A0-022	SHIELDED JUMPER ABM	1	87	

18 x 2

REVISED 10

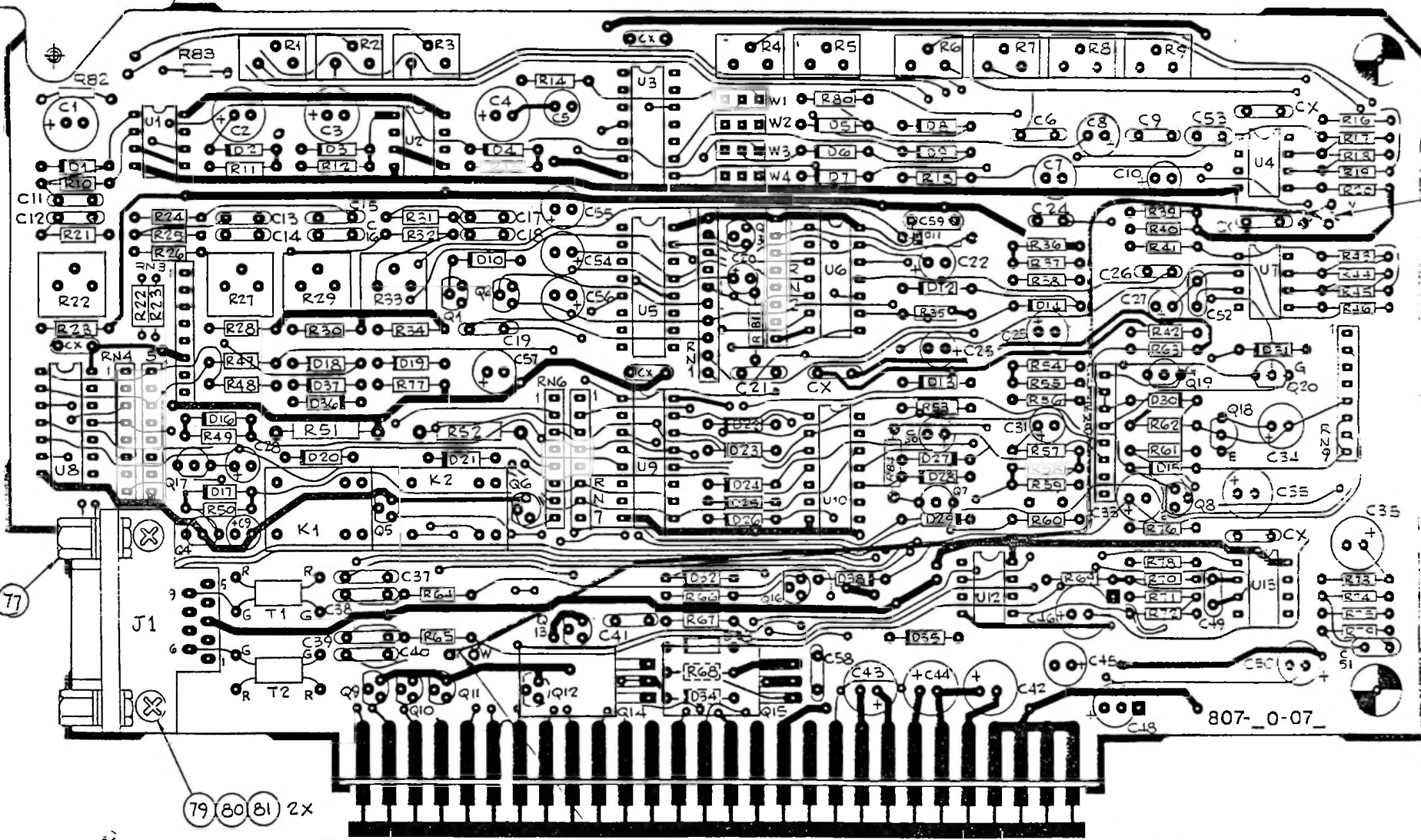

77

79 80 81 2x

— SEE DETAIL "A" —

SEE THIS SIDE TO BE BENT AT 90° THE SIDE UP

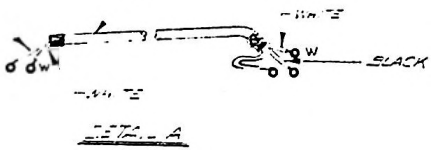

FIDELIPAC Corp. PLAY CUE BD. C712 ASSY DWG. C71A	
MATERIAL APPROVED APPROVED APPROVED	807-CO-076 10/11/53

NOTICE THIS PRINT AND THE INFORMATION SHOWN THEREON IS THE PROPERTY OF FIDELIPAC CORP. AND IS BEING FURNISHED AS A CONFIDENTIAL DOCUMENT. IT MAY NOT BE DELIVERED TO OTHERS NOR REPRODUCED FOR GENERAL CIRCULATION WITHOUT THE WRITTEN APPROVAL OF FIDELIPAC CORP.

REVISIONS				
ZONE	NO	DESCRIPTION	DATE	APPROVED

D  
C  
B  
A

D  
C  
B  
A

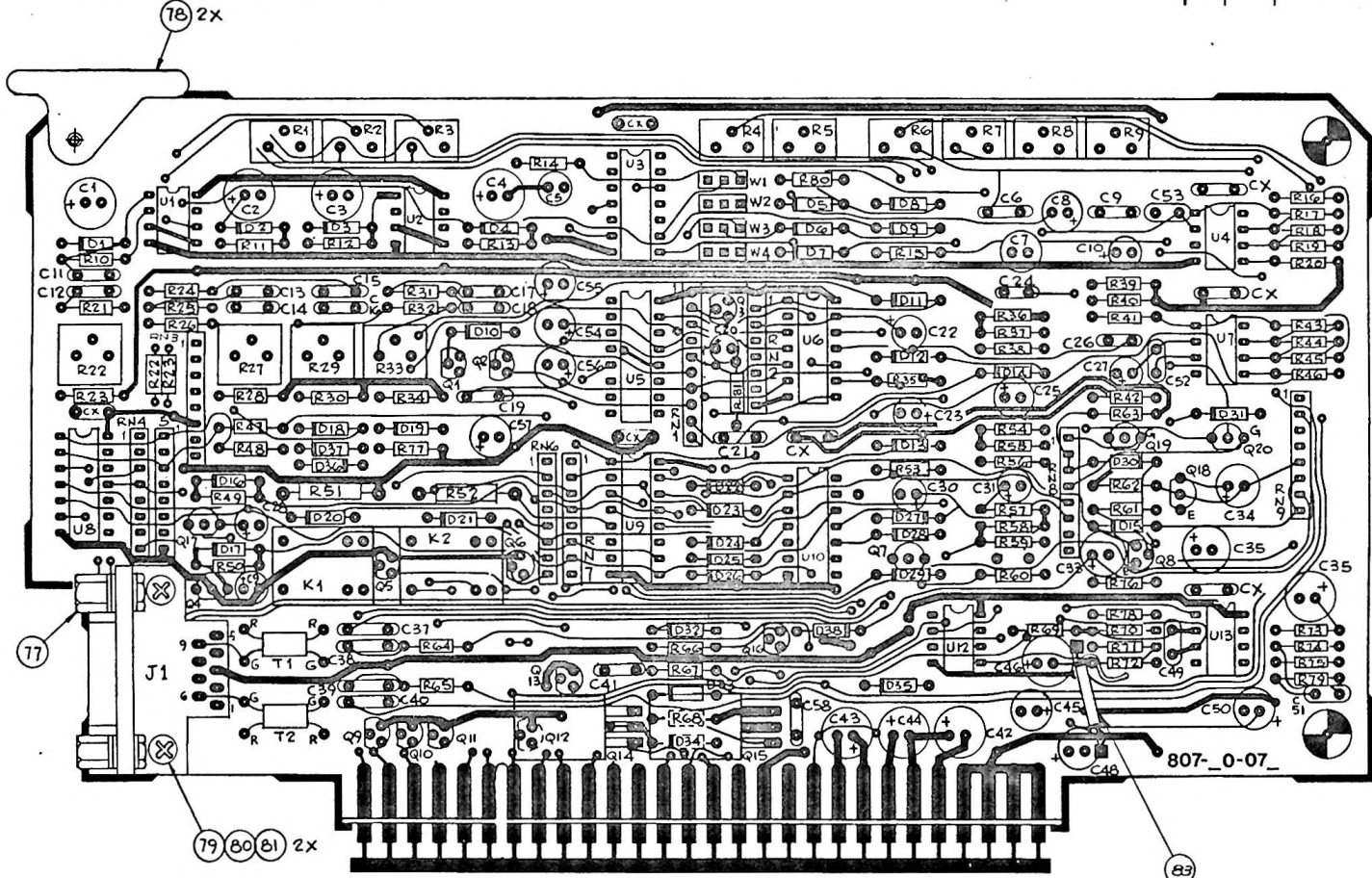

Q14 AND Q15 TO BE BENT AT 90° TAB SIDE UP

MATERIAL	UNLESS OTHERWISE SPECIFIED DIMENSIONS ARE IN INCHES TOLERANCES ON FRACTIONS DECIMALS ANGLES	DRAWN J.K.#	DATE 3-13-66	<b>FIDELIPAC Corp.</b>		
		CHECKED				PLAY CUE BD. CTR 12
		APPROVED			ASSY DWG CTR 14	
					SIZE C	CODE IDENT NO 807-A0-076
				SCALE 2:1	REV NO SHEET 1 OF 1	

CTR 11 & 13 807-A0-075



REVISIONS			
LTR	DESCRIPTION	DATE	APPROVED

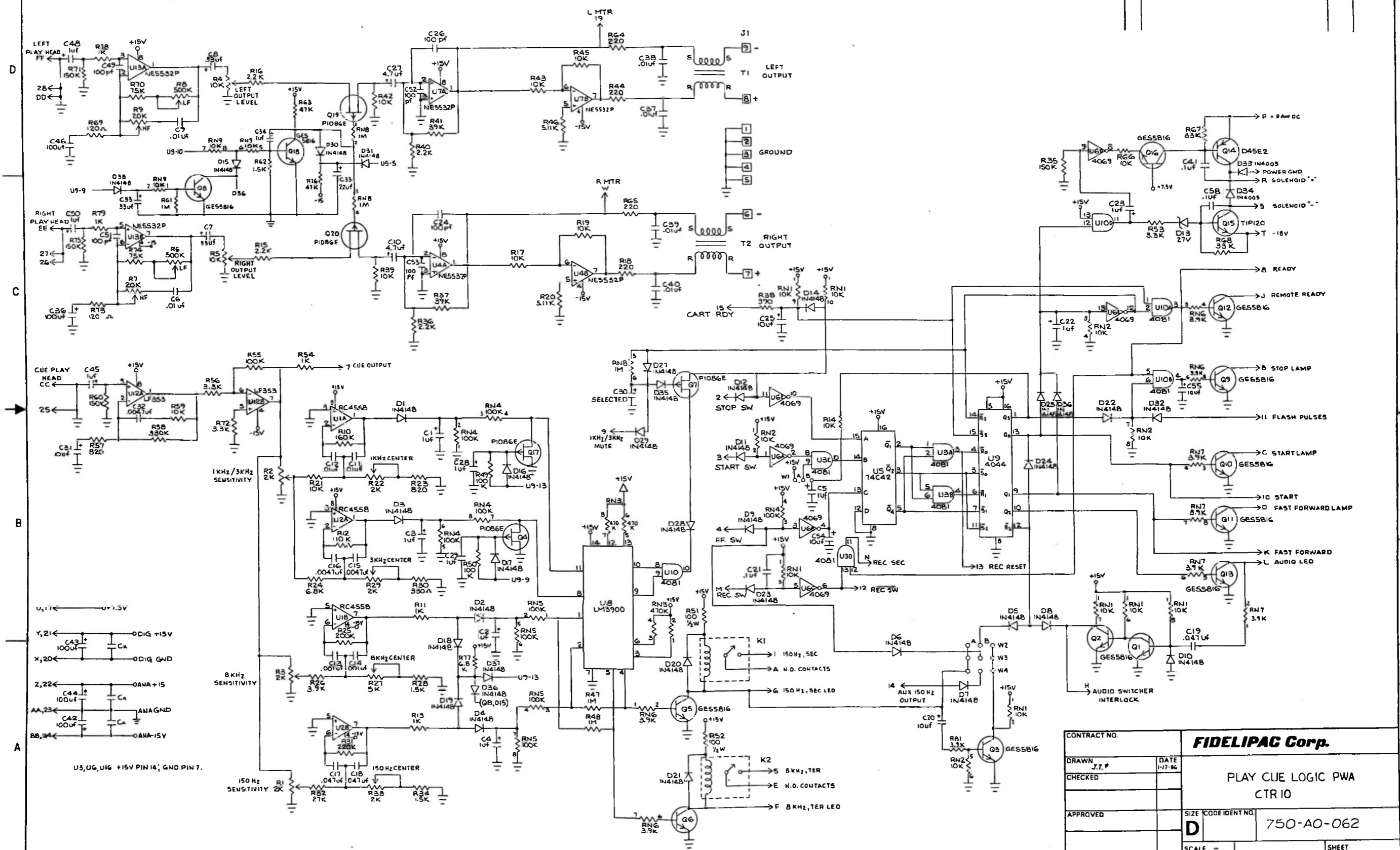

D  
C  
B  
A

D  
C  
B  
A

U3, U6, U16 +15V PIN 14; GND PIN 7.

U17 ← +7.5V

Y, 21 ← ODIG +15V

X, 20 ← ODIG GND

Z, 22 ← OANA +15

AA, 23 ← ANAGND

BB, 24 ← OANA -15V

CONTRACT NO.		<b>FIDELIPAC Corp.</b>	
DRAWN J.T.P.	DATE 1-17-86	PLAY CUE LOGIC PWA CTR 10	
CHECKED			
APPROVED		SIZE CODE IDENT NO	750-AO-062
SCALE -		SHEET	

B	ADD R42, R53, R64, C54 REMOVE ITEM 62 ADD ITEM 64, R6, R6,	2/11/67	J
C	REVISED PER ECN 028	2/15/67	201

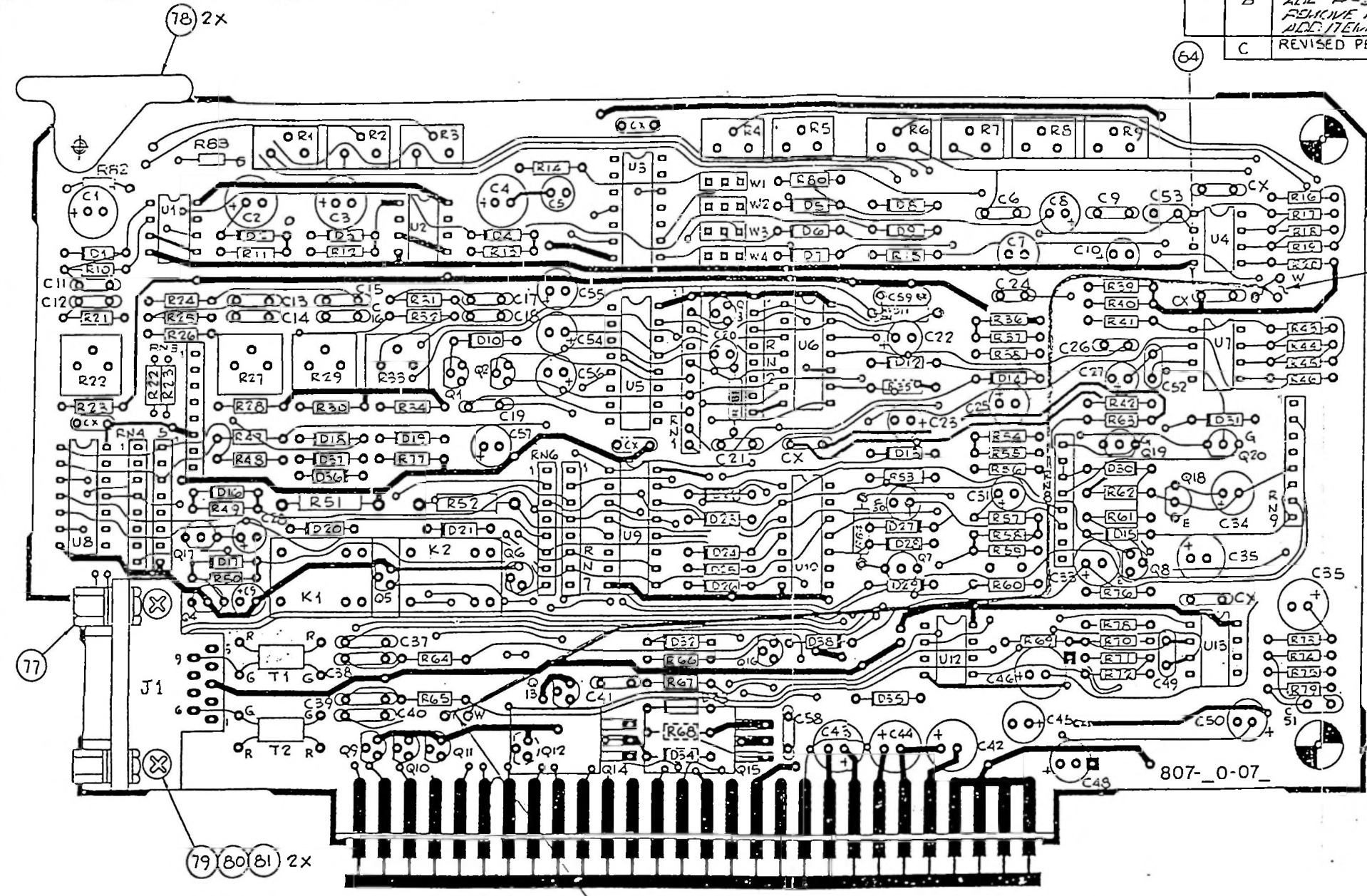

SEE DETAIL "A"

SEE DETAIL "A"

QUANTITY IS TO BE BENT AT 90° THE SIDE UP

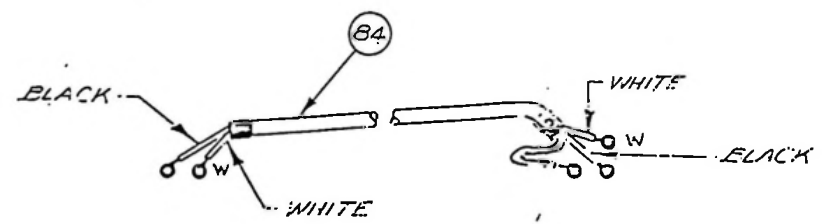

DETAIL A

DATE	3-13-66	<b>FIDELIPAC Corp.</b>
DESIGNED BY		
APPROVED BY		PLAY CUE BD. CIR 12 ASSY DWG CTR 12
DATE		807-E0-076
REVISED BY		

IEC EQUALIZATION:  
 1- REMOVE JUMPER W1 & W2.  
 2- CHANGE R53 & R102 TO +7K.  
 3- INSTALL .01 uF CAPACITORS AT C55 & C66.

REVISIONS		
LTR	DESCRIPTION	DATE APPROVED
B	U13 WAS LF353 NOW NE5532	4/2/82
C	ADDED IEC EQUALIZATION NOTE.	6/8/82
C	CHANGE R50 FROM 15K TO 15K. CHANGE U13 FROM LF353 TO NE5532 EQU 013	11/8/82

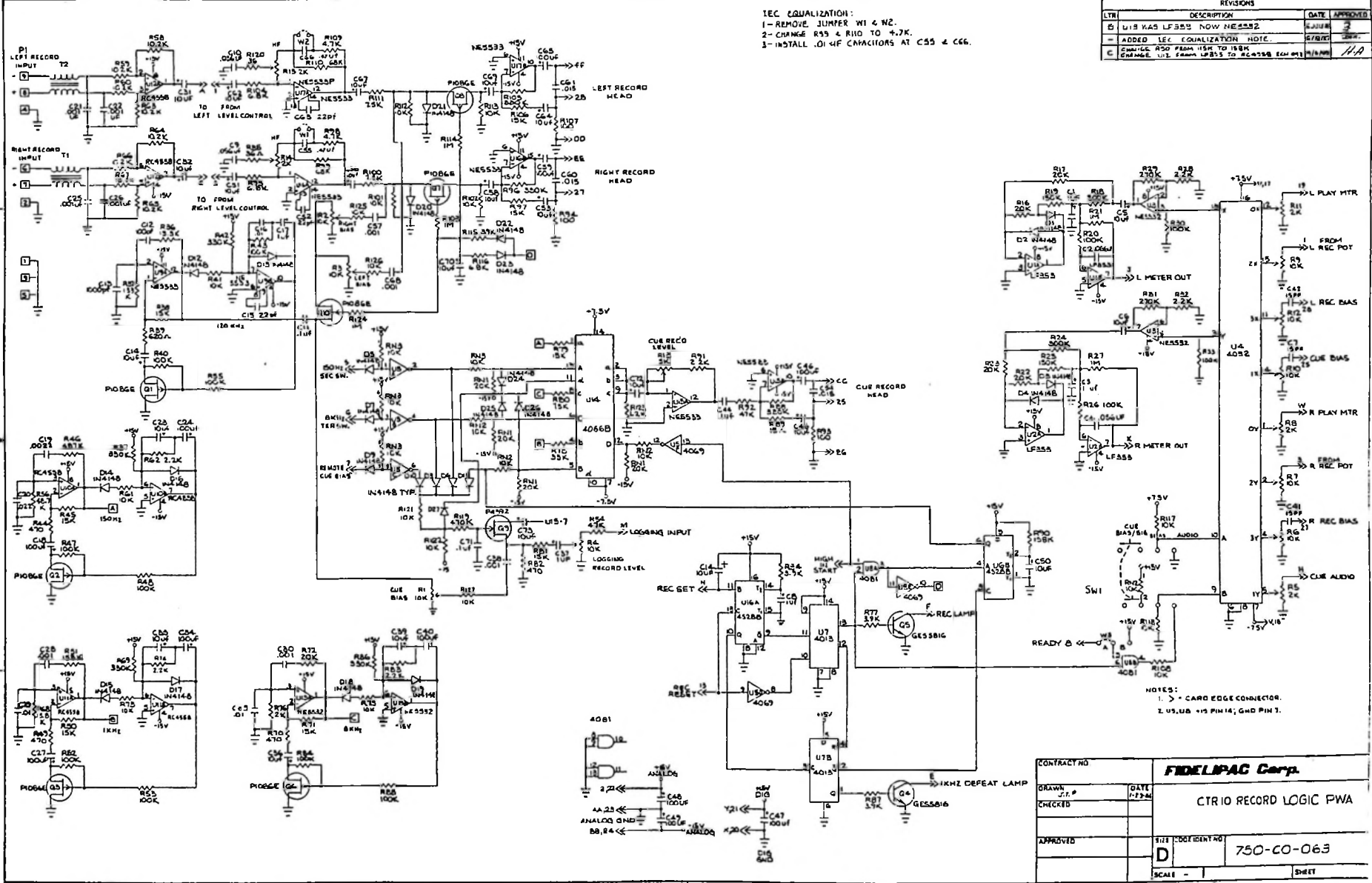

NOTES:  
 1. > CARD EDGE CONNECTOR.  
 2. U5, U8 +5 PIN 14; GND PIN 3.

CONTRACT NO.		<b>FIDELIFAC Corp.</b>	
DRAWN BY P	CHECKED	GATE	DATE
<b>CTR10 RECORD LOGIC PWA</b>			
APPROVED	SHEET NO	750-CO-063	
	D	SCALE -	SHEET

STEREO RECORD AMPLIFIER PWA for CTR10

FOR PARENT ITEM NUMBER 827-C0-081

PART NUMBER	DESCRIPTION	QTY	SEQ	Designator
006-A6-102	.001 uF D CAP	4	1	C22, 25, 26, 51
011-A5-105	1 uF 50V E CAP	5	2	C1, 3, 8, 17, 37
011-A5-106	10 uF 50V E CAP	22	3	C5, 6, 14, 23, 31-33, 36, 39, 45, 50, 51, 53, 56, 58, 62, 64, 67, 69, 70, 72, 73
011-A8-107	100 uF 25V E CAP	9	4	C24, 34, 40, 46-49, 59, 65
011-B5-107	100 uF 10V CAP	2	5	C18, 27
031-A3-101	100 pF S CAP	1	6	C12
031-A3-102	1000 pF S CAP	1	7	C13
031-A3-220	22 pF S CAP	4	8	C25, 43, 52, 63
031-A3-500	50 pf S CAP	i	9	C75
041-A3-102	.001 uF 63V 5 CAP	5	10	C28, 30, 38, 57, 68
041-A3-103	.01 uF 63V 5 CAP	3	11	C16, 29, 35
041-A3-222	.0022 uF 63V 5 CAP	1	12	C19
041-A3-223	.022 uF 63V 5 CAP	1	13	C20
041-A4-104	.1 uF 63V F CAP	4	14	C11, 44, 71, 74
041-A4-153	.015 uF 63V 10 CAP	3	15	C54, 60, 61
041-A4-474	.47 uF 63V F CAP	2	16	C55, 66
041-A4-563	.056 uF 63V F CAP	4	17	C2, 4, 9, 10
110-22-101	100 ohm 1/4W 5% CF Resistor	3	18	R93, 94, 107
110-22-103	10K 1/4W 5% CF Resistor	17	19	R23, 41, 61, 73, 75 101-2, 108, 112-3 117-8, 121-2, 125-7
110-22-104	100K 1/4W 5% CF Resistor	13	20	R20, 26, 30, 33, 40, 47-8, 50, 52-3, 84-5
110-22-105	1M 1/4W 5% CF Resistor	5	21	R21,27,103,114,124
110-22-122	1.2K 1/4W 5% CF Resistor		1	22 R123
110-22-153	15K 1/4W 5% CF Resistor	9	23	R38,45,50,71,79, 81,89,97,106
110-22-154	150K 1/4W 5% CF Resistor	2	24	R19, 25
110-22-203	20K 1/4W 5% CF Resistor	4	25	R16, 17, 22, 23
110-22-222	2.2K 1/4W 5% CF Resistor	6	26	R62,74,83,28,32,91
110-22-274	270K 1/4W 5% CF Resistor	2	27	R29, 31
110-22-304	300K 1/4W 5% CF Resistor	2	28	R18, 24
110-25-333	33K 1/4W 5% CF Resistor	1	29	R78
110-22-334	330K 1/4W 5% CF Resistor	7	30	R42, 57, 69, 86,88, 96, 105

STEREO RECORD AMPLIFIER PWA for CTR10 ...Page 2

FOR PARENT ITEM NUMBER 827-C0-081

PART NUMBER	DESCRIPTION	QTY	SEQ	Designator
110-22-360	36 OHM 1/4W 5%, CF Resistor	2	31	R35, 120
110-22-392	3.9K 1/4W 5% CF Resistor	4	32	R34, 77, 87, 115
110-22-471	470 1/4W 5% CF Resistor	4	33	R44, 49, 70, 82
110-22-472	4.7K 1/4W 5% CF Resistor	2	34	R98, 109
110-22-473	47K 1/4W 5% CF Resistor	2	35	R54, 92
110-22-474	470K 1/4W 5% CF Resistor	2	36	R119
110-52-621	620 OHM 1/4W 5% CF Resistor	1	37	R39
110-22-682	6.8K 1/4W 5% CF Resistor	3	38	R95,104,116
110-22-683	68K 1/4W 5% CF Resistor	2	39	R99,110
110-22-752	7.5K 1/4W 5% CF Resistor	2	40	R100, 111
110-22-753	75K 1/4W 5% CF Resistor	1	41	R80
120-20-10T	10.2K 1/4W 1% MF Resistor	8	42	R58,59,60,63,64, 65,66,67
120-20-13P	1.33K 1/4W 1% MF Resistor	1	43	R37
120-20-13T	13.3K 1/4W 1%, MF Resistor	1	44	R36
120-20-15U	15.8K 1/4W 1% MF Resistor	1	45	R68
120-20-15Y	158K 1/4W 1% MF Resistor	2	46	R51, 90
120-20-20N	2.00 K 1/4 W 1% MF Resistor	1	47	R76
120-20-20S	20K 1/4W 1% MF Resistor	1	48	R72
120-20-48S	48.7K 1/4W 1% MF Resistor	1	49	R56
120-20-48W	487K 1/4W 1% MF Resistor	1	50	R46
13M-33-103	10K VERTICAL TRIM	9	51	R1-4, 6,7,9,10,12
13M-33-202	2K VERTICAL TRIM	5	52	R5, 8, 11, 14, 15
13M-33-502	5K VERTICAL TRIM POT	1	53	R13
144-11-103	Resistor, NET., 10K-4	2	54	RN2, 3
144-11-203	Resistor, NET., 20K-4	1	55	RN1
200-A0-000	1N4148 DIODE	27	56	D1-27
210-A0-002	MPS2222 Transistor	2	57	Q4, 5
220-A0-000	P1086E P FET Transistor	7	58	Q1-3, 6, 7, 8, 10
220-A0-002	P4392 Transistor	1	59	Q9
230-A0-000	5532 DUAL OP-AMP IC	2	60	U3, 13
230-A0-001	5533 DUAL OP-AMP IC	4	61	U9, 15, 16, 27
230-A0-008	LF353 IC	2	62	U1,U2
230-A0-010	RC4558 IC	3	63	U10, 11, 12
231-A0-024	4052 IC,**RCA ONLY***	1	64	U4
231-A0-026	4066 IC (NOT RCA)	1	65	U14
231-A0-027	4528 IC (NATIONAL ONLY)	1	66	U6
231-A0-028	4081 IC	1	67	U8
231-A0-030	4069 IC	1	68	U5
231-A0-034	4013 IC (NATIONAL ONLY)	1	69	U7

STEREO RECORD AMPLIFIER PWA for CTR10 ... Page 3

FOR PARENT ITEM NUMBER 827-C0-081

PART NUMBER	DESCRIPTION	QTY	SEQ	Designator
300-A0-000	INDUCTOR BALUN	4	70	T1, 2
361-A0-005	SLIDE SWITCH, DP 3 POS	1	71	SW1
407-B0-080	PCB, RECORD	1	72	
410-A0-001	8 PIN DIP SOCKET	7	73	U1-3, 10-13
410-A0-002	14 PIN DIP SOCKET	8	74	U5, 7-9, 14-17
410-A0-003	16 PIN DIP SOCKET	2	75	U4, 6
417-A0-000	9 PIN D RT ANGLE PLUG	1	76	P1
416-A0-001	RT ANGLE D CONN HARDWARE	1	77	P1
420-A0-001	BUS WIRE 22 AWG	0	78	W1, 2, 3A
5AB-A0-007	BOARD EJECTOR	2	79	P1
601-20-440	NUT HEX 4-40 STEEL PLATE	2	80	P1
60C-11-400	LOCK WASHER I.T. #4	2	81	
621-05-440	SCREW P.H. PHIL 4-40 X 5/16 PL	2	82	P1

RECORD BOARD

74 2X

CRANGE J12

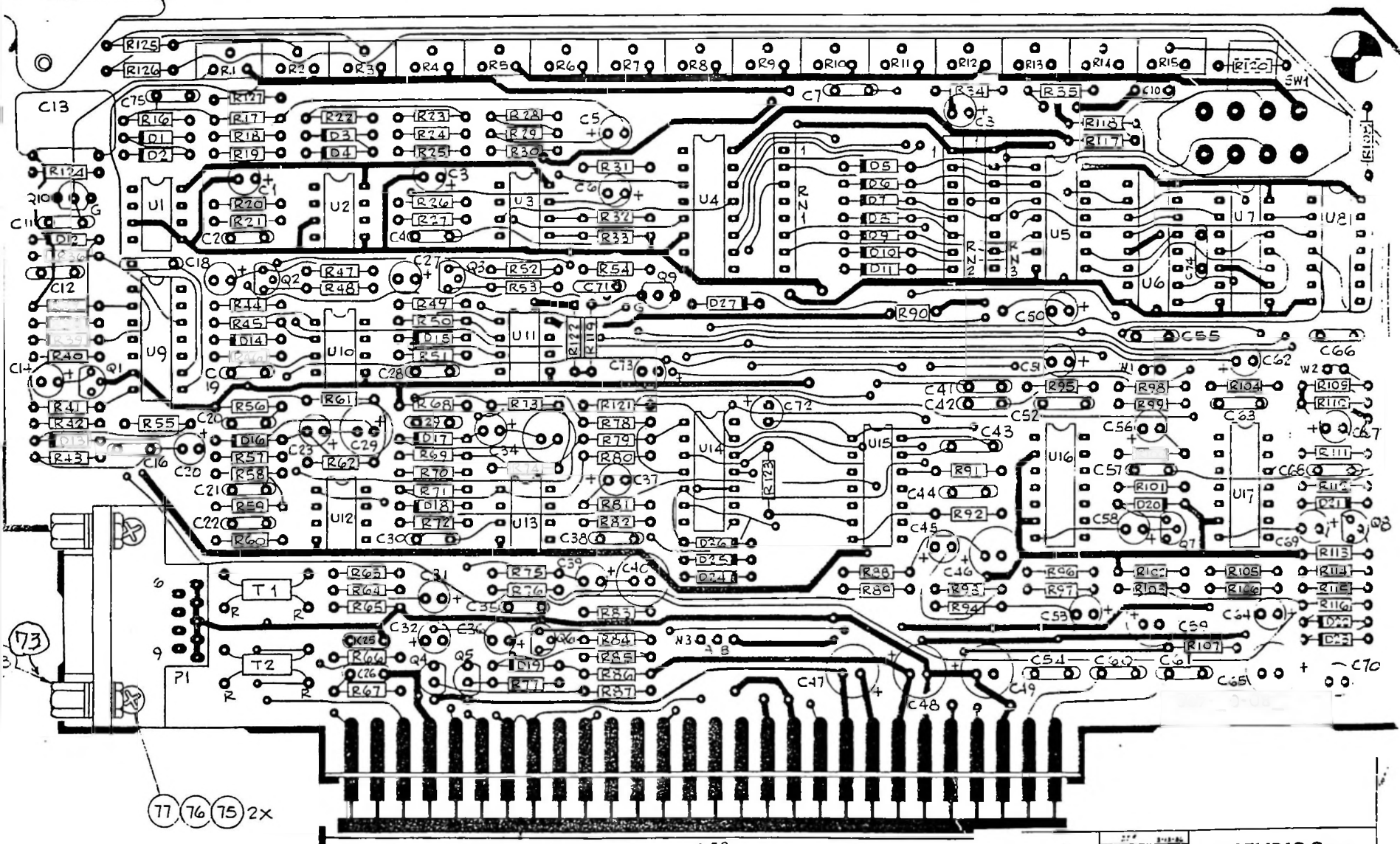

77 76 75 2X

4.50

FIDELIPAC Corp.	
RECORD BOARD ASSY GNG	
REV C	507-CO-081
DATE	REV
BY	CHK
APP	APP

507-CO-050

NOTICE: THIS PRINT AND THE INFORMATION HEREON IS THE PROPERTY OF  
 AND IS BEING FURNISHED AS A CONFIDENTIAL ENCLOSURE  
 IT MAY NOT BE DELIVERED TO OTHERS NOR BE REPRODUCED FOR GENERAL CIRCULATION WITHOUT THE WRITTEN  
 APPROVAL OF

ZONE	NO	DESCRIPTION	DATE	APPROVED

C 13 FLAT AGAINST BOARD

74 2x

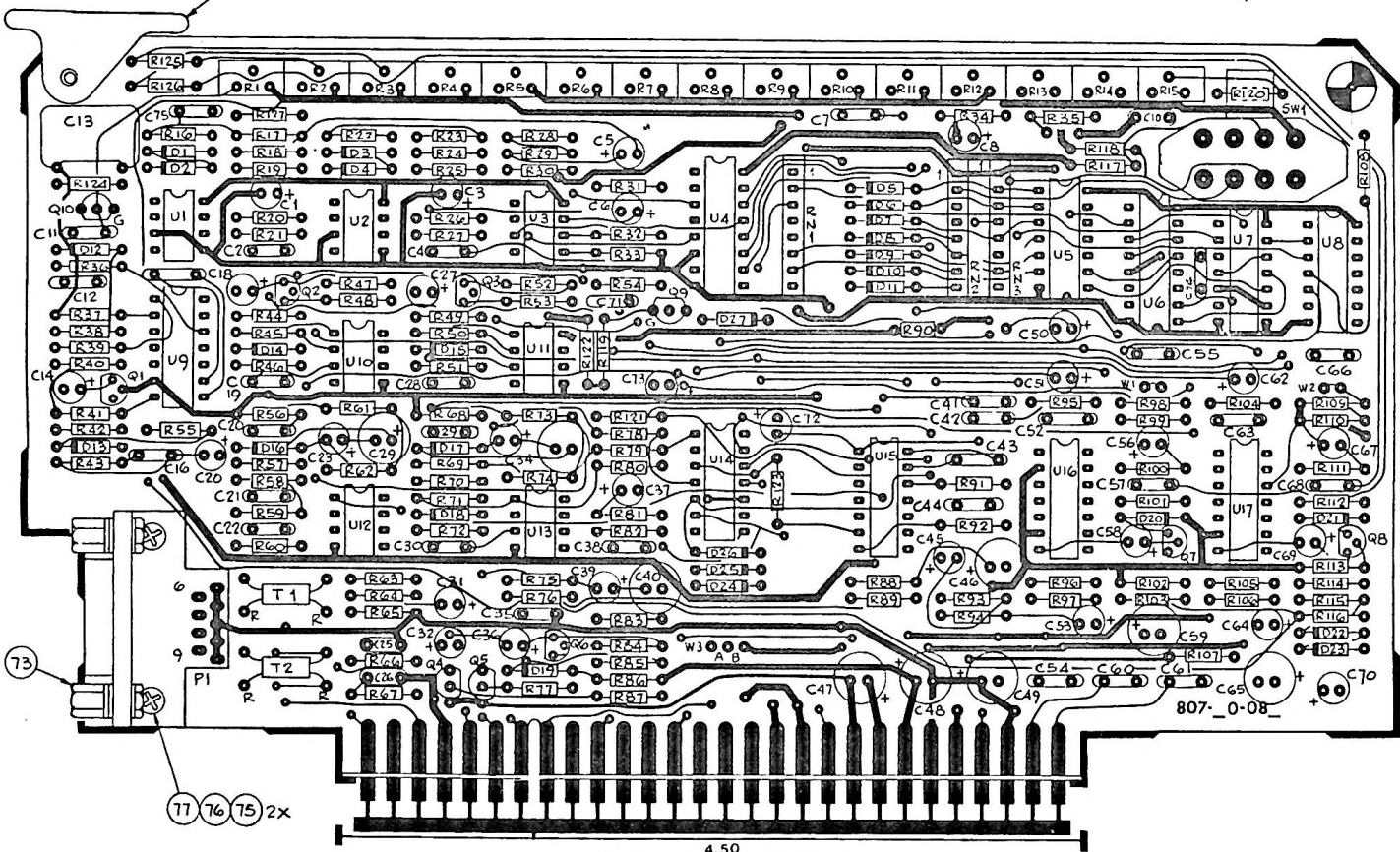

4.50

MATERIAL	DRAWN J.T.P.	DATE 9-18-66	<b>FIDELIPAC Corp.</b>  RECORD BOARD ASSY DWG CTR 14  SIZE C CODE IDENT NO 807-A0-081 SCALE 2:1 REV. NO. SHEET 1 OF 1
	CHECKED		
	APPROVED		
	APPROVED		
APPROVED			

CTR 13 807-A0-081



REVISIONS			
LTR	DESCRIPTION	DATE	APPROVED

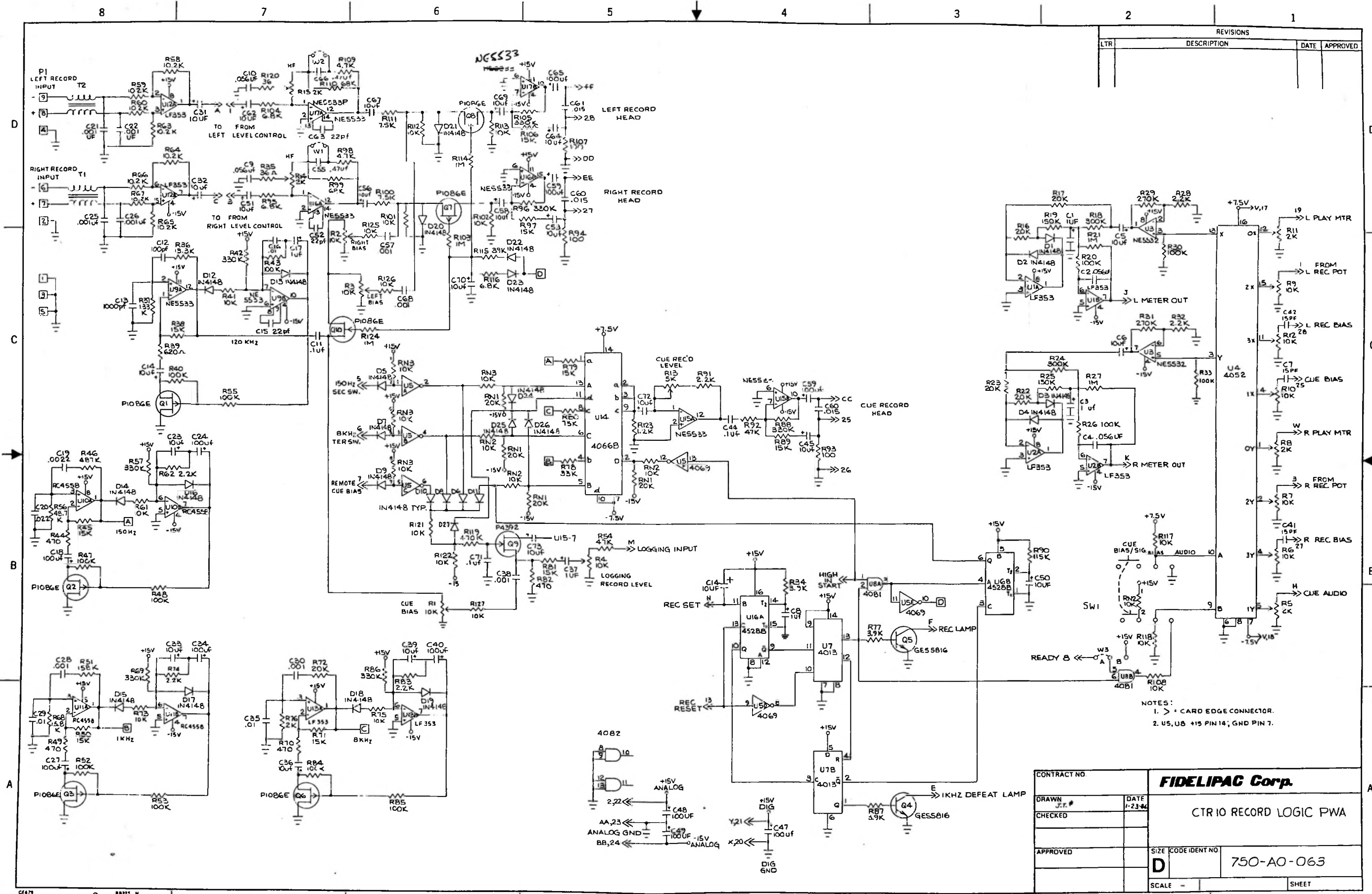

- NOTES:  
 1. > = CARD EDGE CONNECTOR.  
 2. U5, U8 +15V PIN 14, GND PIN 7.

CONTRACT NO.		<b>FIDELIPAC Corp.</b>	
DRAWN J.T.#	DATE 1-23-84	CTR 10 RECORD LOGIC PWA	
CHECKED		SIZE	CODE IDENT NO <b>D</b> 750-A0-063
APPROVED		SCALE	SHEET

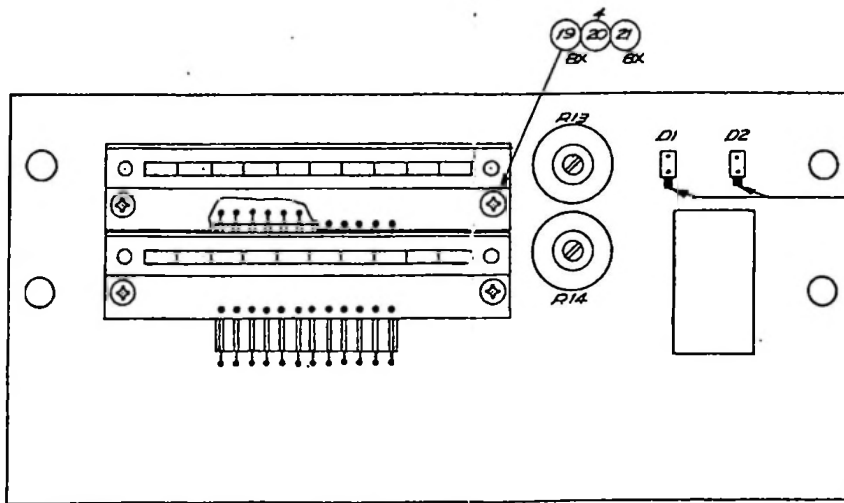
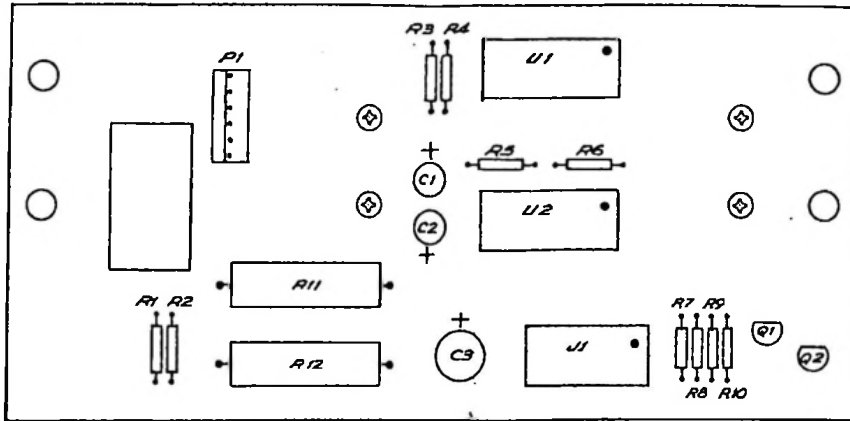

SHORT LED LEAD THIS SIDE  
 DO NOT SOLDER OR CUT LEADS  
 UNTIL FINAL ASSEMBLY OF FRONT PANEL.

DESIGNED BY	FIDELI-FAC CORP MOORESTOWN, N.J.	
DATE	SCALE	REVISIONS
APPROVED BY	VU METER PWA, CTR IQ RPS	
DATE	REVISION NUMBER	
27 OCT 65	807-A0-101	

VU METER PWA for CTR10 (RECORDER ONLY)

FOR PARENT ITEM NUMBER 807-A0-101

PART NUMBER	DESCRIPTION	QTY	SEQ	Designator
011-A5-106	10 uF 50V E CAP	2	1	C1, 2
011-A8-107	100 uF 25V E CAP	1	2	C3
110-22-103	10K 1/4W 5% CF Resistor	4	3	R7-10
110-22-122	1.2K 1/4W 5% CF Resistor	2	4	R4, 5
110-22-752	7.5K 1/4W 5% CF Resistor	2	5	R3, 6
110-32-681	680 1/2W 5% CF Resistor	2	6	R1, 2
13T-33-202	2K H IT TRIM	2	7	R13, 14
150-82-500	50 5W 5% WW Resistor	2	8	R11, 12
210-A0-003	2N4403 Transistor	2	9	Q1, 2
236-A0-002	LM3916N IC	2	10	U1, 2
250-A0-003	RED LED	1	11	D1
250-A0-004	GREEN LED	1	12	D2
407-A0-299	VU METER PCB	1	14	
410-A0-003	16 PIN DIP SOCKET	1	15	J1
410-A0-007	18 PIN DIP SOCKET	2	16	U1, 2
416-A0-011	HEADER MTA 100 6 POS	1	17	P1
5B2-A0-022	SPACER-HEX 3/16 X 5/8 X 2-56	4	18	
60C-11-200	L'WASHER I.T. #2	8	19	M1, 2
6B2-A0-007	SPACER 3/16 K 3/4 2-56 BRASS	4	20	M1, 2
621-04-256	SCREW P.H. PHIL 2-56 X 1/4 SP	8	21	M1, 2
807-A0-021	LED BARGRAPH METER	2	22	M1, 2
110-22-820	82 OHM Y7W 5% CF Resistor	3	23	R15-18
250-A0-298	GREEN LED	7	24	D3-9
250-A0-299	RED LED	2	25	D10-12
407-A0-299	BAR GRAPH PCB	1	26	
425-A0-000	DIP JUMPER 12 POS 2 INCH	2	27	

4 | 3 | 2 | 1

REVISIONS			
REV	DESCRIPTION	DATE	APPROVED

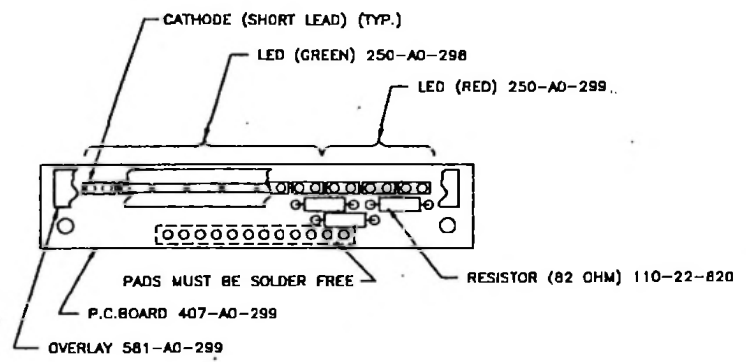

COMPONENT SIDE

QTY REQD	QTY REQD	QTY REQD	DRAWING NO.	DESCRIPTION

MATERIAL:		REMOVE ALL BURRS BREAK SHARP EDGES .015 ± .010		<small>UNLESS OTHERWISE SPECIFIED DIMENSIONS ARE IN INCHES AND DECIMALS THEREOF TOLERANCES ON</small> UP TO 6 .021 FROM 6 .03 ABOVE 24 .04 .000 .010 .015		CONTRACT NO. DESIGNED BY T.J.W. 8/11/58 CHECKED BY H.A. 9/11/58 APPROVED BY		FIDELIPAC CORP. MOORESTOWN, N.J. BARGRAPH VJ-PWA	
FINISH:	NEXT ASSY.	USED ON	UNLESS OTHERWISE SPECIFIED THE SURFACE FINISH OF MACHINED PART SHALL NOT EXCEED 1/32" MAX.	SCALE 2:1	SHEET 1 OF 1	DRAWING NO. 807-A0-299 DATE 8/11/58			

DATE	REVISION RECORD	NUMBER	CH

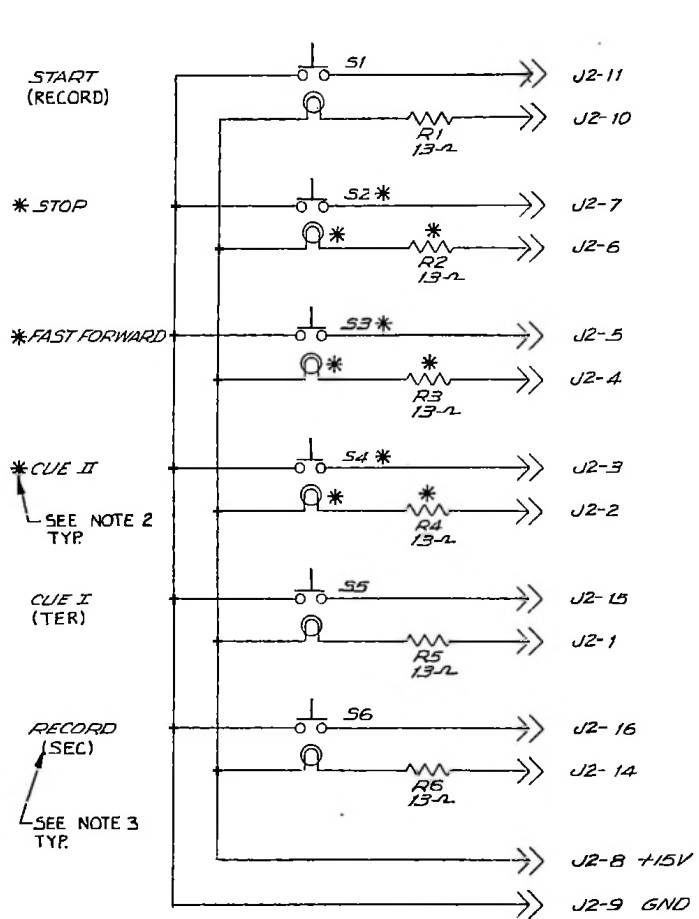

SEE NOTE 2 TYP

SEE NOTE 3 TYP

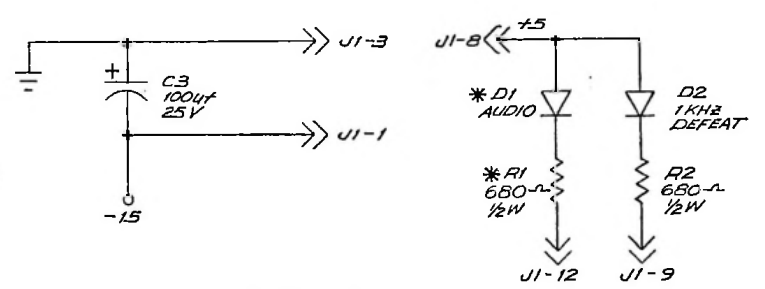
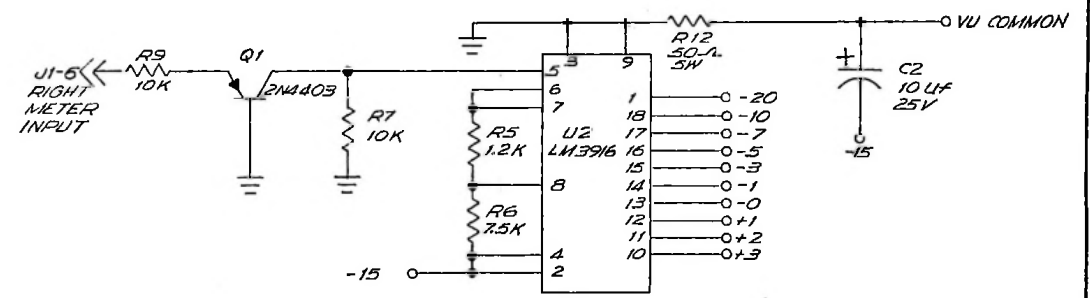
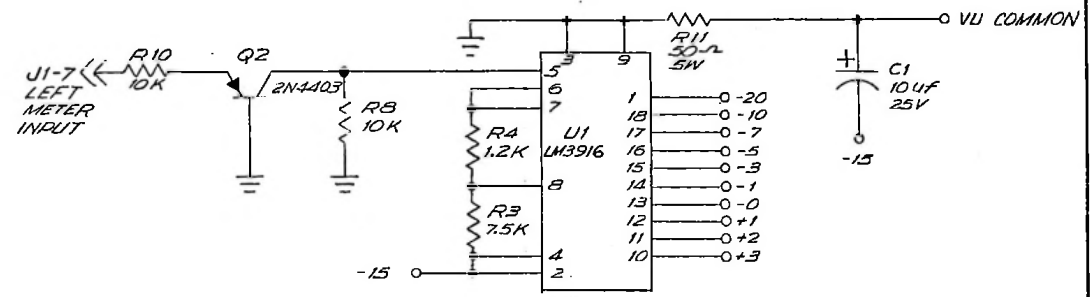
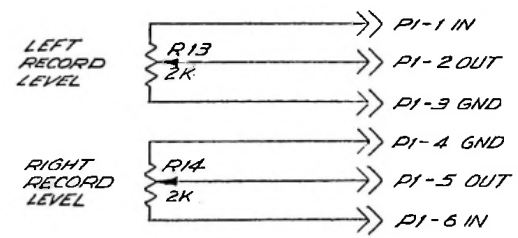

- NOTES:
- 1- ALL ITEMS ARE USED IN CTR10 UNITS.
  - 2- ITEMS MARKED WITH \* ARE NOT IN CTR30 UNITS.
  - 3- ITEMS MARKED WITH ( ) ARE PUSHBUTTON DESIGNATIONS FOR CTR30 UNITS.

TOLERANCES (UNLESS OTHERWISE SPECIFIED)		FIDELIRAC CORP MOORESTOWN, N.J.	
DECIMAL		SCALE	
FRACTIONAL		APPROVED BY	
ANGULAR		TITLE	SCHMATIC, PWA-FNT PNL
DATE		DRAWING NUMBER	750-10-064

DATE	REV	REVISION RECORD	AUTHOR	CHK

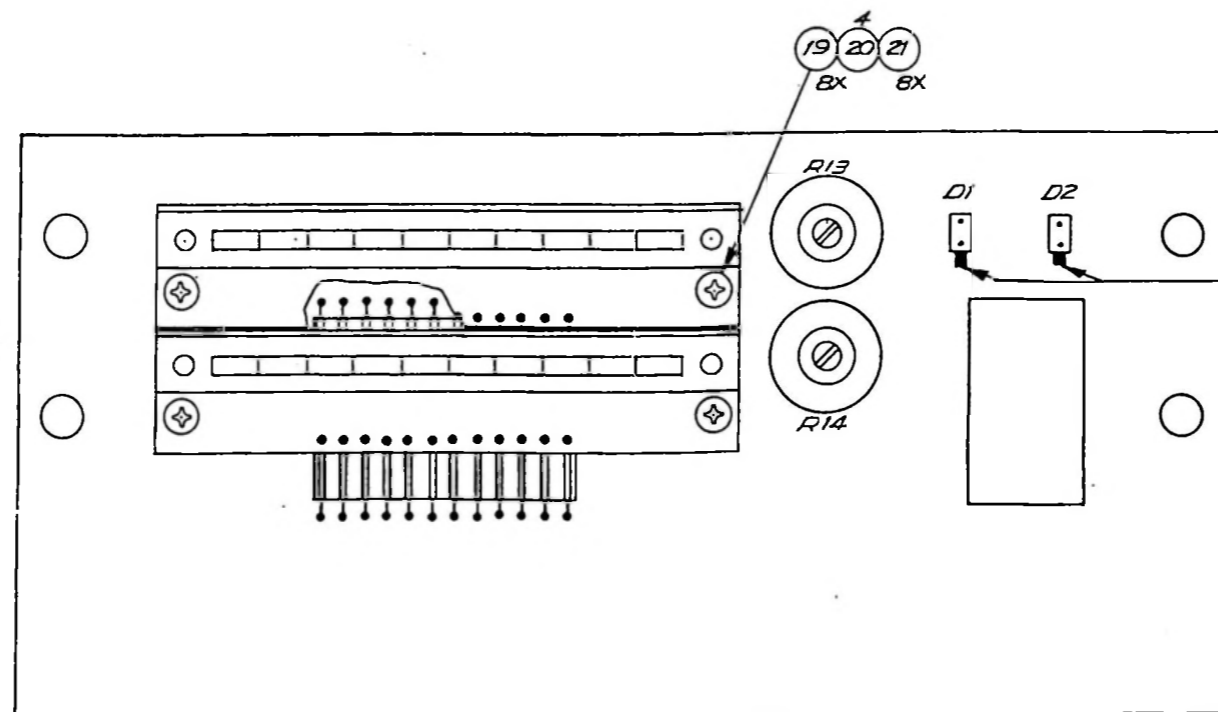
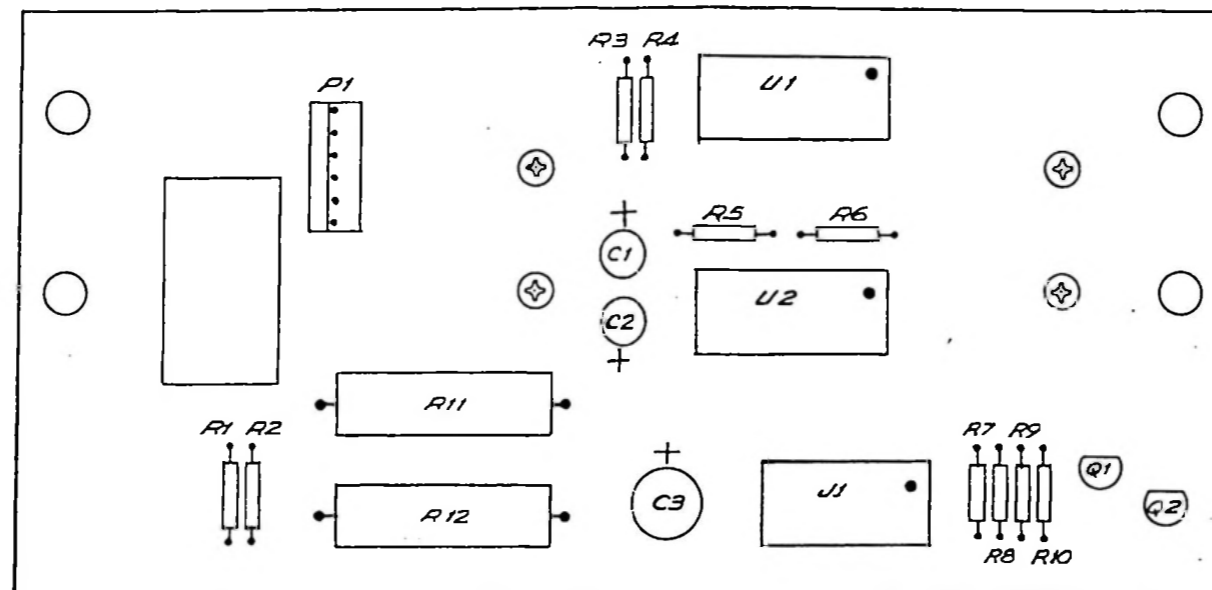

SHORT LED LEAD THIS SIDE  
DO NOT SOLDER OR CUT LEADS  
UNTIL FINAL ASSEMBLY OF FRONT PANEL.

TOLERANCES UNLESS OTHERWISE SPECIFIED	FIDELIPAC CORP. MOORESTOWN, N.J.		
DECIMAL	SCALE	DRAWN BY <u>  </u>	
FRACTIONAL		APPROVED BY <u>  </u>	
ANGULAR	DATE	DRAWING NUMBER	
	27 OCT 85	807-AD-101	

REV	DESCRIPTION	DATE	BY	CHK

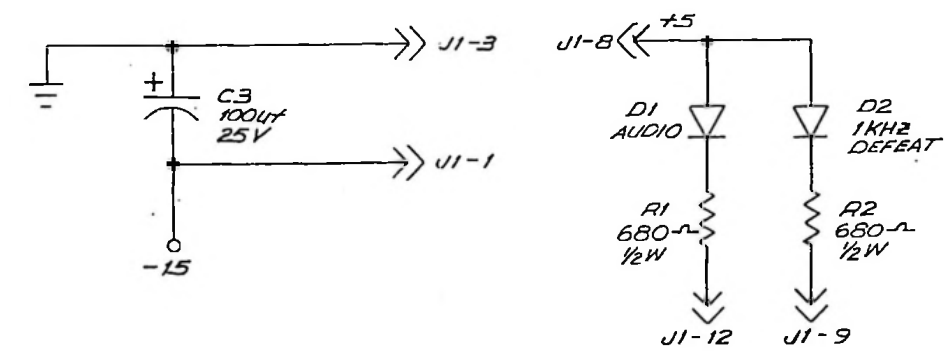
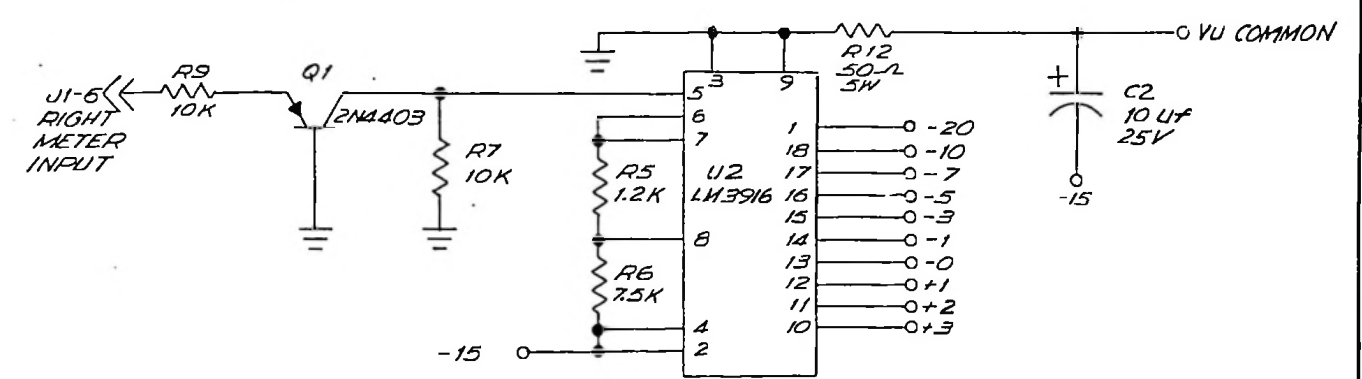
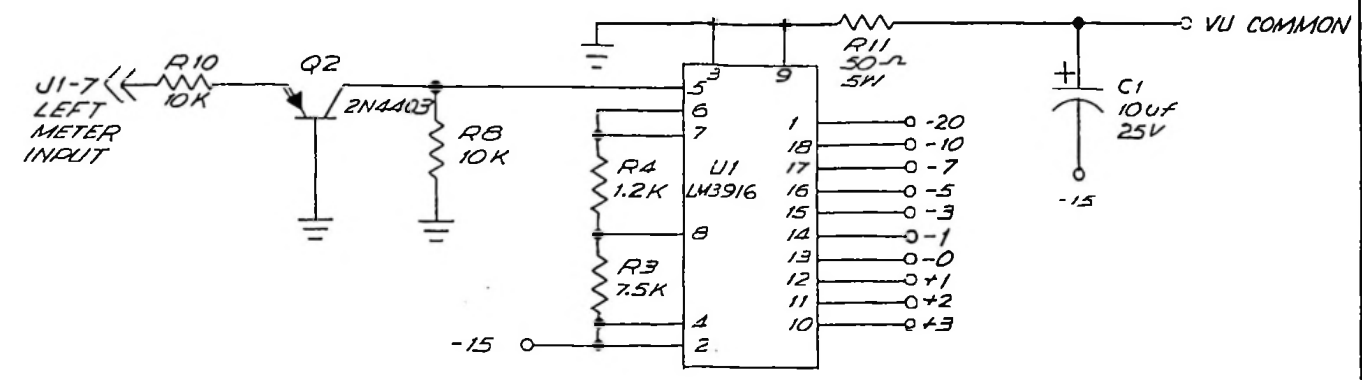
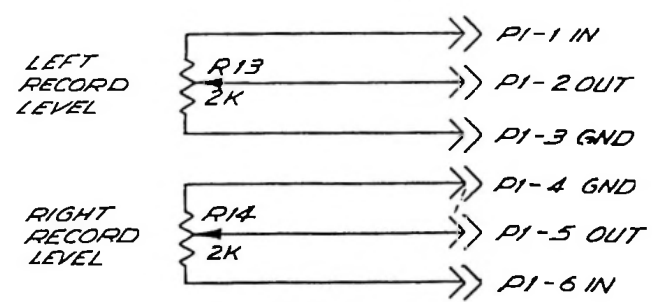
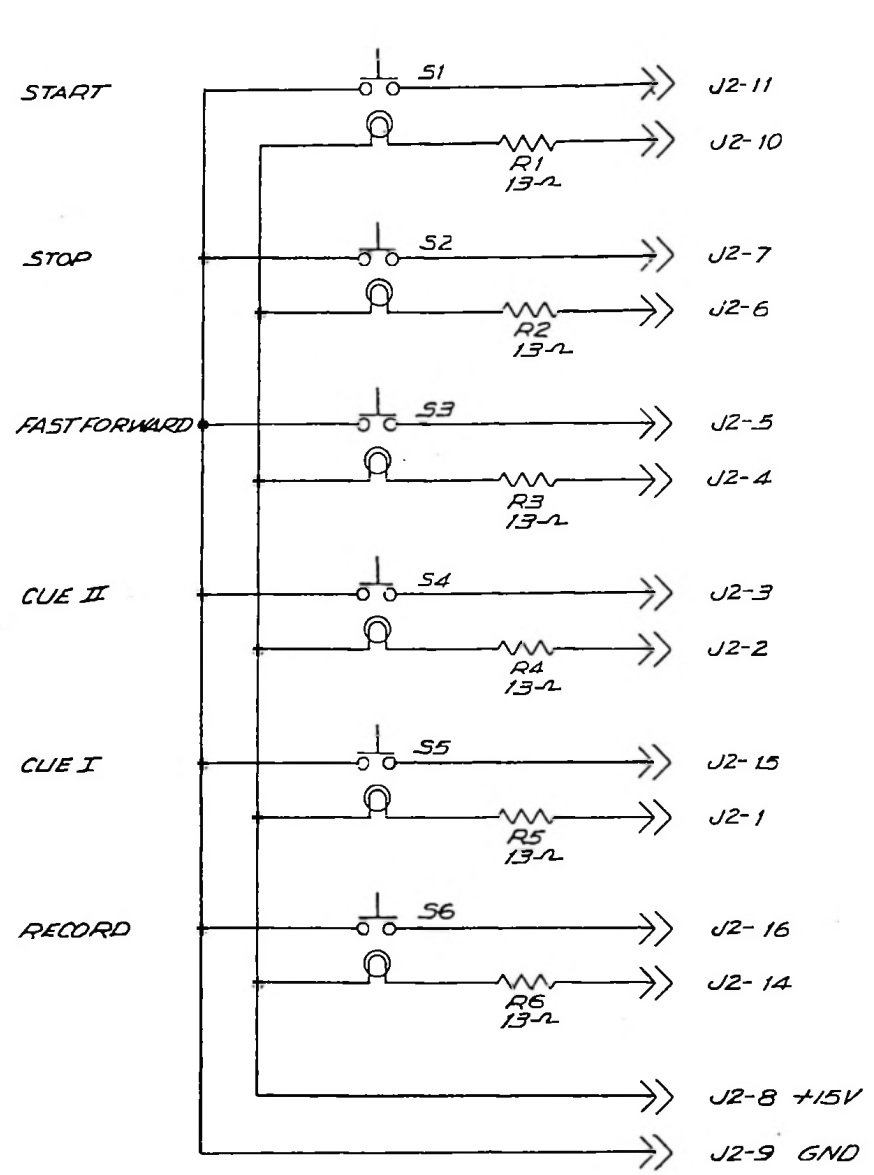

TOLERANCE	FIDELIPAC CORR MOORESTOWN, N.J.		
DECIMAL	SCALE	DRAWN BY	APPROVED BY
FRACTIONAL	TITLE		
ANGULAR	DATE	DRAWING NUMBER	
	20 DEC 85	750-A0-064	

REV C ADD R37

DATE	BY	REVISION RECORD	AUTH	DR	CK

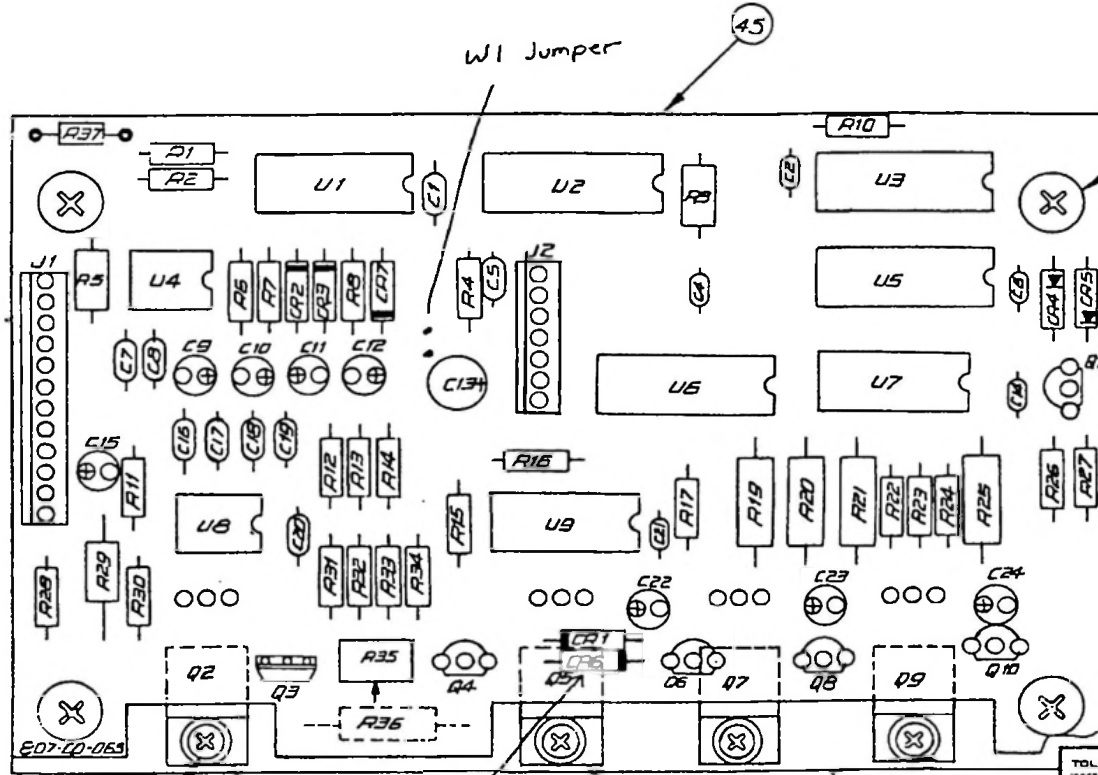

NOTE:  
SEE SCHEMATIC 75D-BD-058

807-CO-065

48 4X  
49 4X

31 47

IN34A  
CR6

30 47  
3X 3X

46

TOLERANCES (EXCEPT AS NOTED)		FIDELIPAC CORP MOORESTOWN, N.J.	
DECIMAL		SCALE	DRAWN BY
FRACTIONAL			APPROVED BY
ANGULAR		TITLE <b>SERVO PCB</b>	
	DATE	DRAWING NUMBER	
	25 JUL 64	807-CO-065	



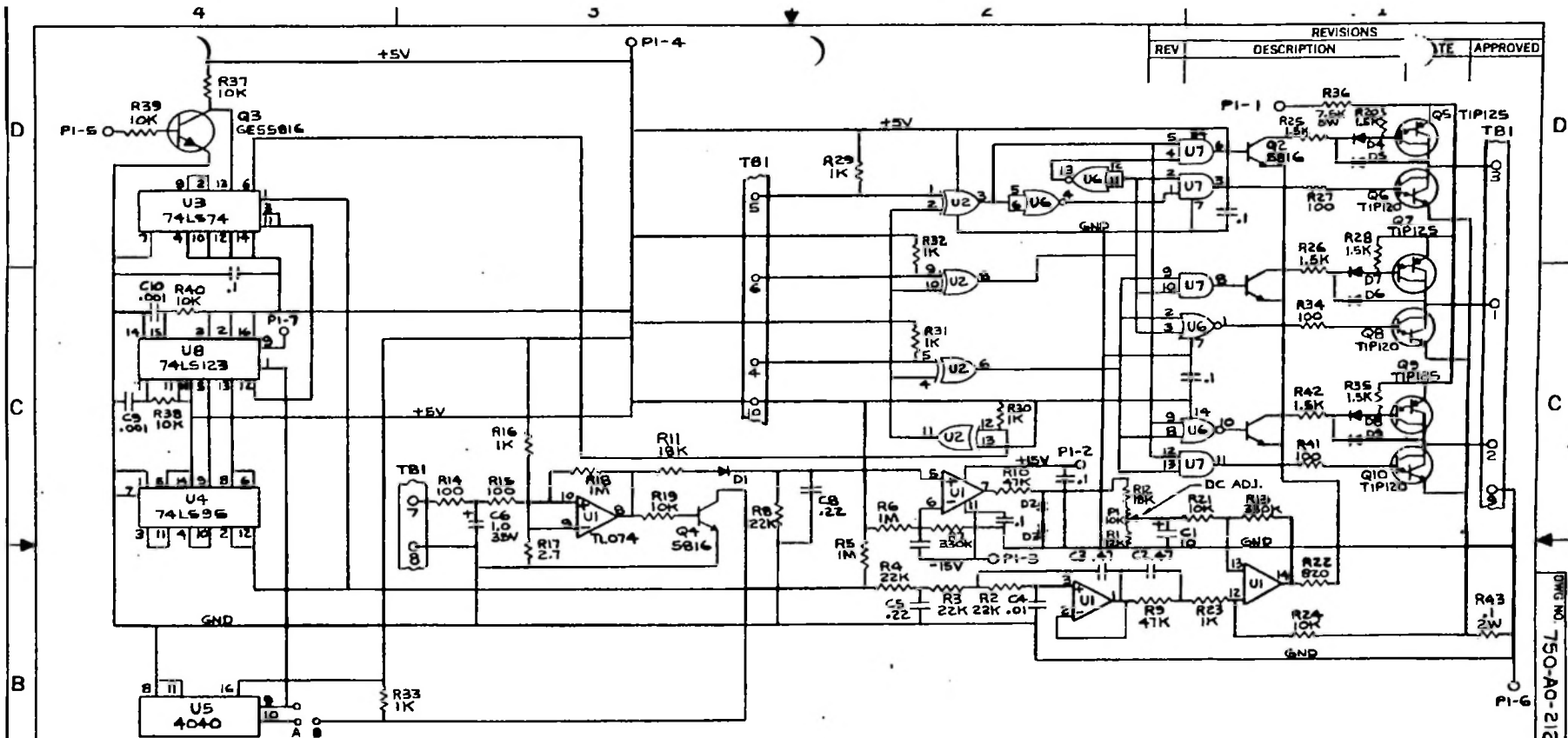

REVISIONS			
REV	DESCRIPTION	DATE	APPROVED

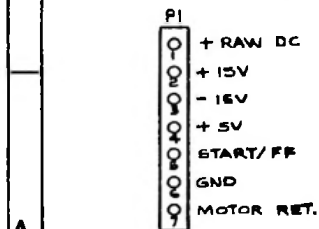

- NOTES:**
1. ALL RES. 1/4W, 5% UNLESS NOTED
  2. ALL CAPS. IN UF UNLESS NOTED
  3. ALL DIODES IN 4448 UNLESS NOTED
  4. O = ON BOARD CONNECTORS

QTY REQD	ITEM NO	PART OR IDENTIFYING NO	DRAWING NO	DESCRIPTION

<b>MATERIAL:</b>		REMOVE ALL BURRS BREAK SHARP EDGES .015 ± .010		CONTRACT NO.		<b>FIDELIPAC CORP.</b> MOORESTOWN, N.J. <b>SERVO BOARD</b> <b>SCHEMATIC</b>	
<b>FINISH:</b>		UNLESS OTHERWISE SPECIFIED THE SURFACE FINISH OF MACHINED PART SHALL NOT EXCEED 125/ MAX.		DRAWN BY: T.J.W. DATE: 3-31-68 CHECKED BY: APPROVED BY:			
NEXT ASSY	USED ON	UP TO 6 3.02 ± .005		APPROVED BY:		SIZE: C	CODE IDENT NO: 750-A0-212
		ABOVE 24 2.04 ± .015				SCALE	DWG NO: 750-A0-212
		ANGULAR DIM. 1/2°					REV: 34 REV

DWG NO. 750-A0-212 34 REV

REVISIONS			
REV	DESCRIPTION	DATE	APPROVED

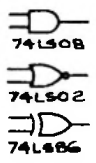
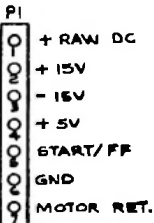
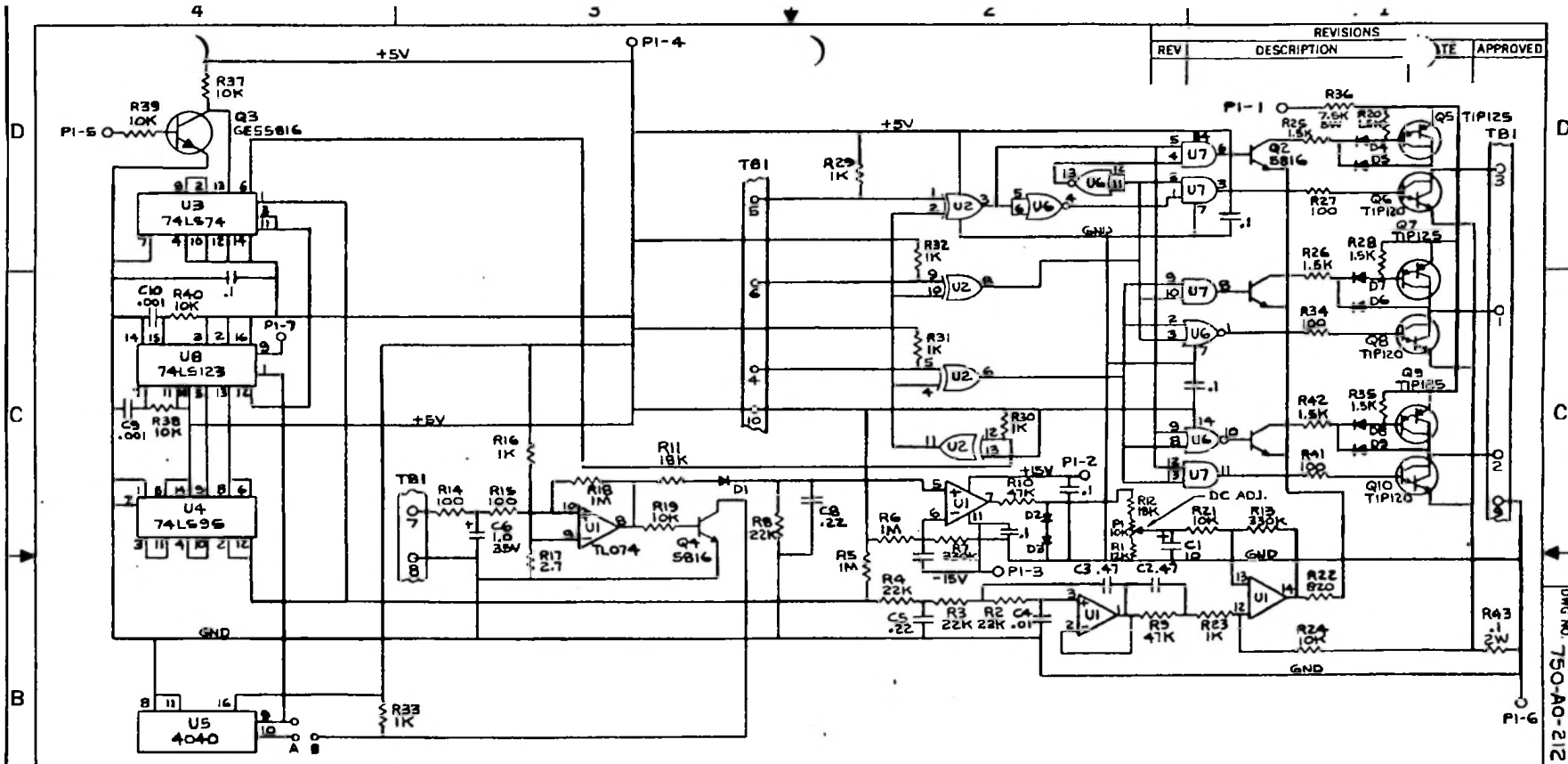

- NOTES:
1. ALL RES. 1/4W, 5% UNLESS NOTED
  2. ALL CAPS. IN UF UNLESS NOTED
  3. ALL DIODES IN 4448 UNLESS NOTED
  4. Q's ON BOARD CONNECTORS

QTY REQD	ITEM NO	PART OR IDENTIFYING NO	DRAWING NO	DESCRIPTION

PARTS LIST

MATERIAL:		REMOVE ALL BURRS BREAK SHARP EDGES .015 ± .010		CONTRACT NO.			
FINISH:		UNLESS OTHERWISE SPECIFIED THE SURFACE FINISH OF MACHINED PART SHALL NOT EXCEED 125/ MAX		DRAWN BY T.J.W DATE 8-31-78			
NEXT ASSY	USED ON	TOLERANCES ON		CHECKED BY		SERVO BOARD SCHEMATIC	
		HOLE ± .005 UP TO .6 ± .02 .6 TO 2.5 ± .03 2.5 TO 25 ± .04 ANGULAR DIM ± 1/2°		APPROVED BY		SIZE CODE IDENT NO 750-A0-212	
						SCALE	
						SHEET 1 OF 1	

DWG NO 750-A0-212 SH REV

SERVO PWA for CTR10 ...page 1

FOR PARENT ITEM NUMBER 807-C0-065

PART NUMBER	DESCRIPTION	QTY	SEQ	Designator
006-A6-103	PANASONIC 4300a-ND	6	1	
006-B4-100	10 pf D CAP	2	2	
011-A5-105	1 uF 50 V E CAP	2	3	
011-A5-106	10 uF 50V E CAP	6	4	
011-A5-107	100 uF 25V E CAP	1	5	
041-A3-102	.001 uF 50V CAP	1	6	
041-A3-103	.01 uF 63V 5 CAP	2	7	
041-A4-104	.1 uF 63V F CAP	2	8	
041-A4-224	.22 uF 63V F CAP	1	9	
110-22-101	100 ohm 1/4W 5% CF Resistor	1	10	
110-22-102	1K 1/4W 5% CF Resistor	1	11	
110-22-103	10K 1/4W 5% CF Resistor	4	12	
110-22-104	100K 1/4W 5% CF Resistor	3	13	
110-22-105	1M 1/4W 5% CF Resistor	1	14	
110-22-223	22K 1/4W 5% CF Resistor	3	15	
110-22-272	2.7 1/4W 5% CF Resistor	1	16	
110-22-333	33K 1/4W 5% CF Resistor	3	17	
110-22-334	330K 1/4W 5% CF Resistor	2	18	
110-22-392	3.9K 1/4W 5% CF Resistor	1	19	
110-22-472	4.7K 1/4W 5% CF Resistor	5	20	
110-22-474	470K 1/4W 5% CF Resistor	1	21	
110-22-683	68K 1/4W 5% CF Resistor	2	22	
110-32-101	100 ohm 1/2W 5% CF Resistor	1	23	
110-32-471	470 ohm 1/2W 5% CF Resistor	3	24	
110-32-560	56 ohm 1/2W 5% CF Resistor	1	25	
13M-33-501	500 ohm Vertical Trim Resistor	1	26	
150-72-33B	.33 ohm 3W 5% WW Resistor	1	27	
200-A0-000	1N4148 DIODE	6	28	
210-A0-002	MPS2222	5	29	
211-A0-003	MPSU05 Transistor	1	30	
211-A0-005	MJE2955T Transistor	3	31	
211-A0-006	MJE3055T Transistor	1	32	
230-A0-009	LM358 IC (NATIONAL ONLY)	2	33	
231-A0-003	74LS00 IC	1	34	
231-A0-011	74LS123 IC (NOT MOTOROLA)	1	35	
231-A0-023	4040 IC	1	36	
231-A0-025	4053 IC **** RCA ONLY ****	1	37	
231-A0-030	4069 IC	1	38	
231-10-034	4013 IC (NATIONAL ONLY)	1	39	
231-A0-041	74LS195 IC	1	40	

SERVO PWA for CTR10 ...page 2

FOR PARENT ITEM NUMBER 807-C0-065

PART NUMBER	DESCRIPTION	QTY	SEQ	Designator
407-C0-065	SERVO PCB	1	41	
410-A0-001	SOCKET DIP 8 PIN	2	42	
410-A0-002	SOCKET DIP 14 PIN	3	43	
410-A0-003	SOCKET DIP 16 PIN	4	44	
416-A0-012	MTA 100 7 POS HEADER	1	45	
416-A0-013	MTA 100 12 POS HEADER	1	46	
440-A0-000	TO220 SIL PAD INSULATOR	4	47	
541-C0-020	MOTOR BOARD MOUNTING PLATE	1	48	
607-01-124	SHOULDER WASHER	4	49	
621-03-440	SCREW P.H. 4-40 X 3.16 PL	4	50	
621-05-632	SCREW P.H. PHIL 6-32 X 5/16PL	4	51	

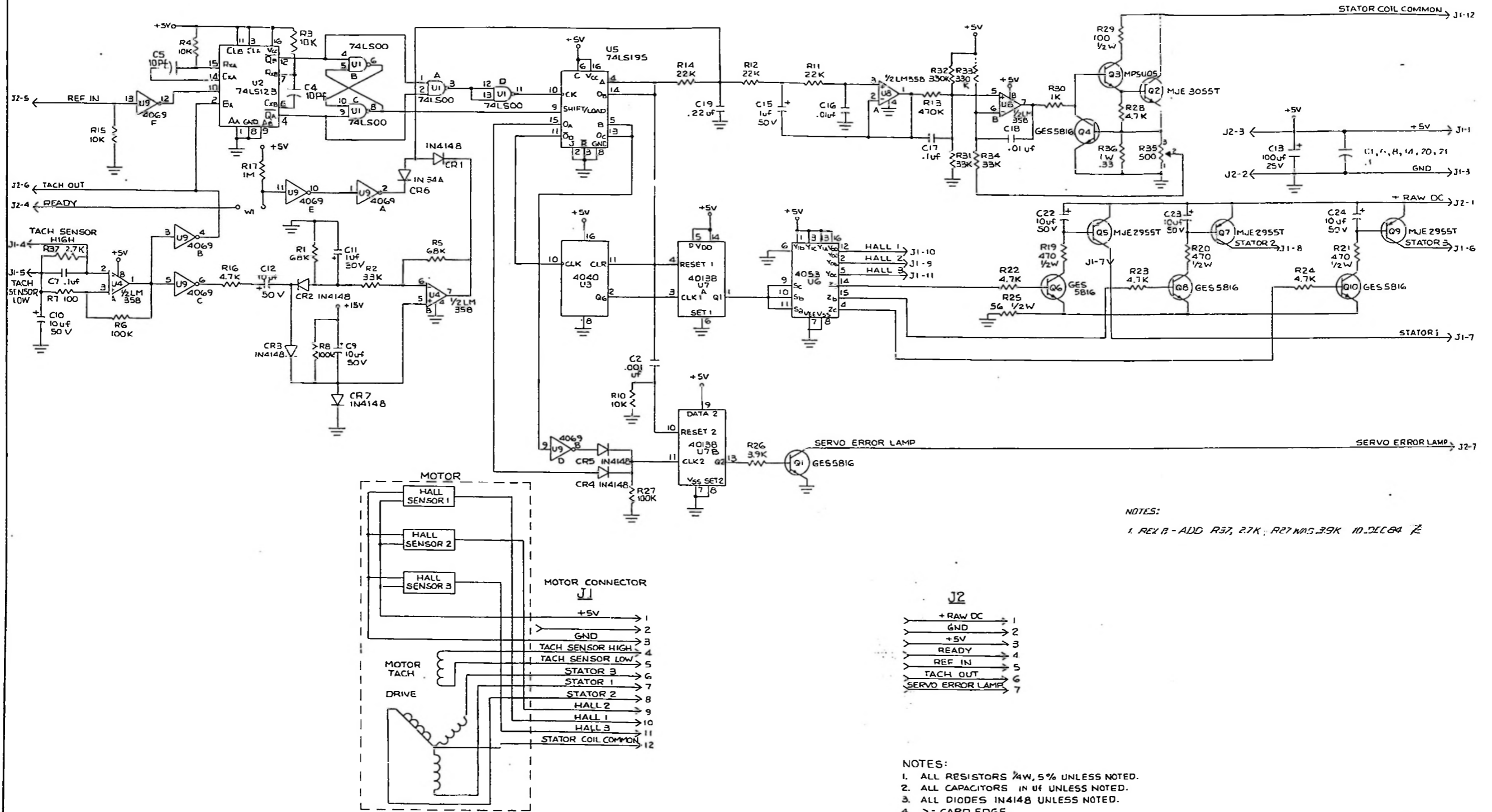

NOTES:

1. REV B - ADD R37, 2.7K; R27 WAS 39K 10 DEC 84 Z

NOTES:

1. ALL RESISTORS 1/4W, 5% UNLESS NOTED.
2. ALL CAPACITORS IN UF UNLESS NOTED.
3. ALL DIODES IN4148 UNLESS NOTED.
4. > = CARD EDGE.

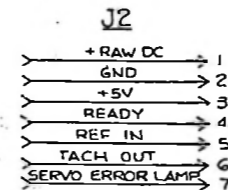

REVISIONS		DATE		BY	
1					
2					
3					
4					
5					
6					
7					
8					
9					
10					
11					
12					
13					
14					
15					
16					
17					
18					
19					
20					
21					
22					
23					
24					
25					
26					
27					
28					
29					
30					
31					
32					
33					
34					
35					
36					
37					
38					
39					
40					
41					
42					
43					
44					
45					
46					
47					
48					
49					
50					

**FIDELIPAC**  
SERVO BOARD  
SCHEMATIC CTR 100

DESIGNED BY: J.T. # \_\_\_\_\_ DATE: 8-15-84  
DRAWN BY: \_\_\_\_\_ CHECKED BY: \_\_\_\_\_  
75080-055

REV C ADD R37

DATE	SYM	REVISION RECORD	AUTH	DR.	CK.

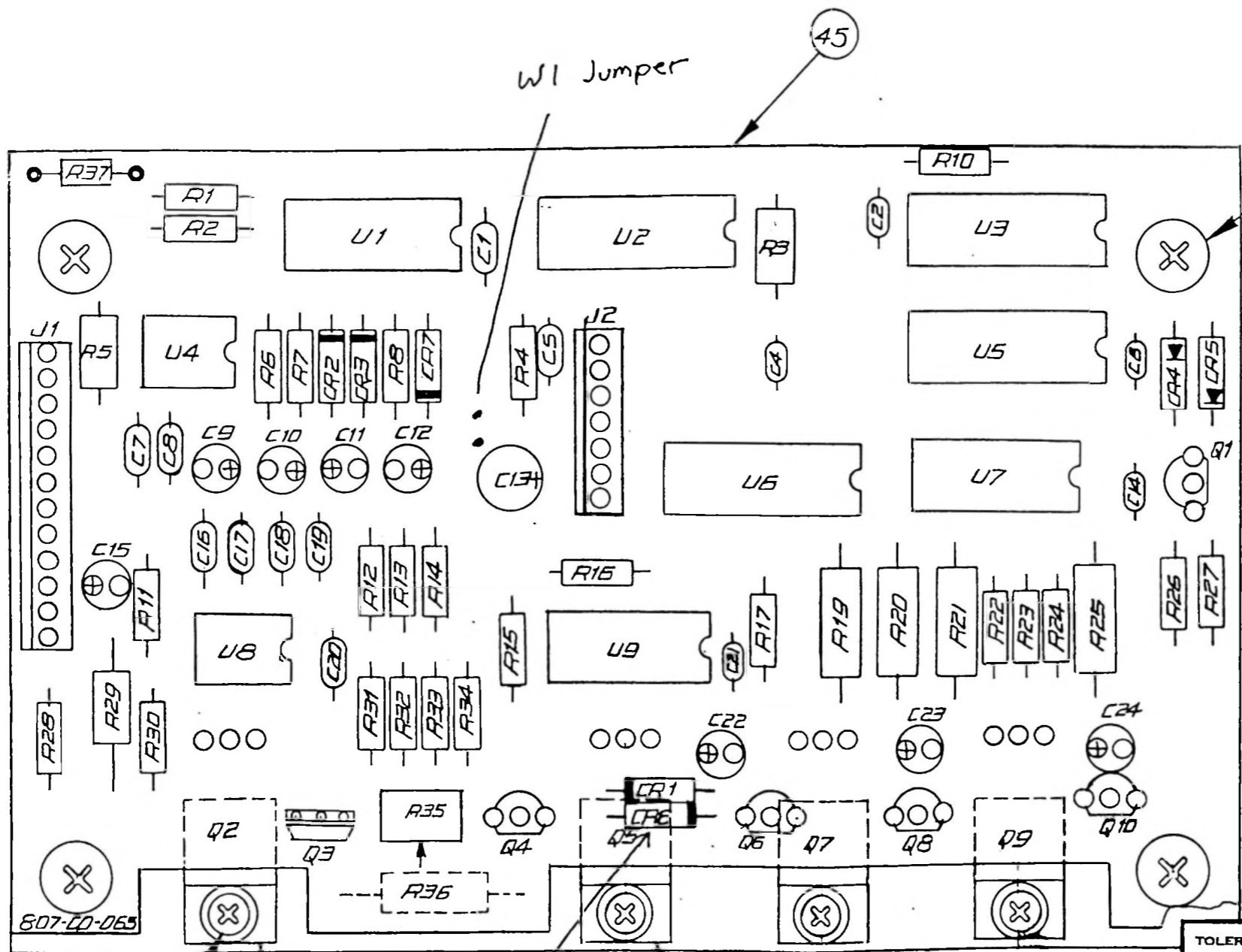

NOTE:  
SEE SCHEMATIC 75D-BD-058

807-CO-065

TOLERANCES (EXCEPT AS NOTED)		FIDELIPAC CORP MOORESTOWN, N.J.	
DECIMAL		SCALE	DRAWN BY
±		~	APPROVED BY
FRACTIONAL		TITLE	
±		SERVO PCB	
ANGULAR		DATE	DRAWING NUMBER
±		25 JULY 84	807-CO-065

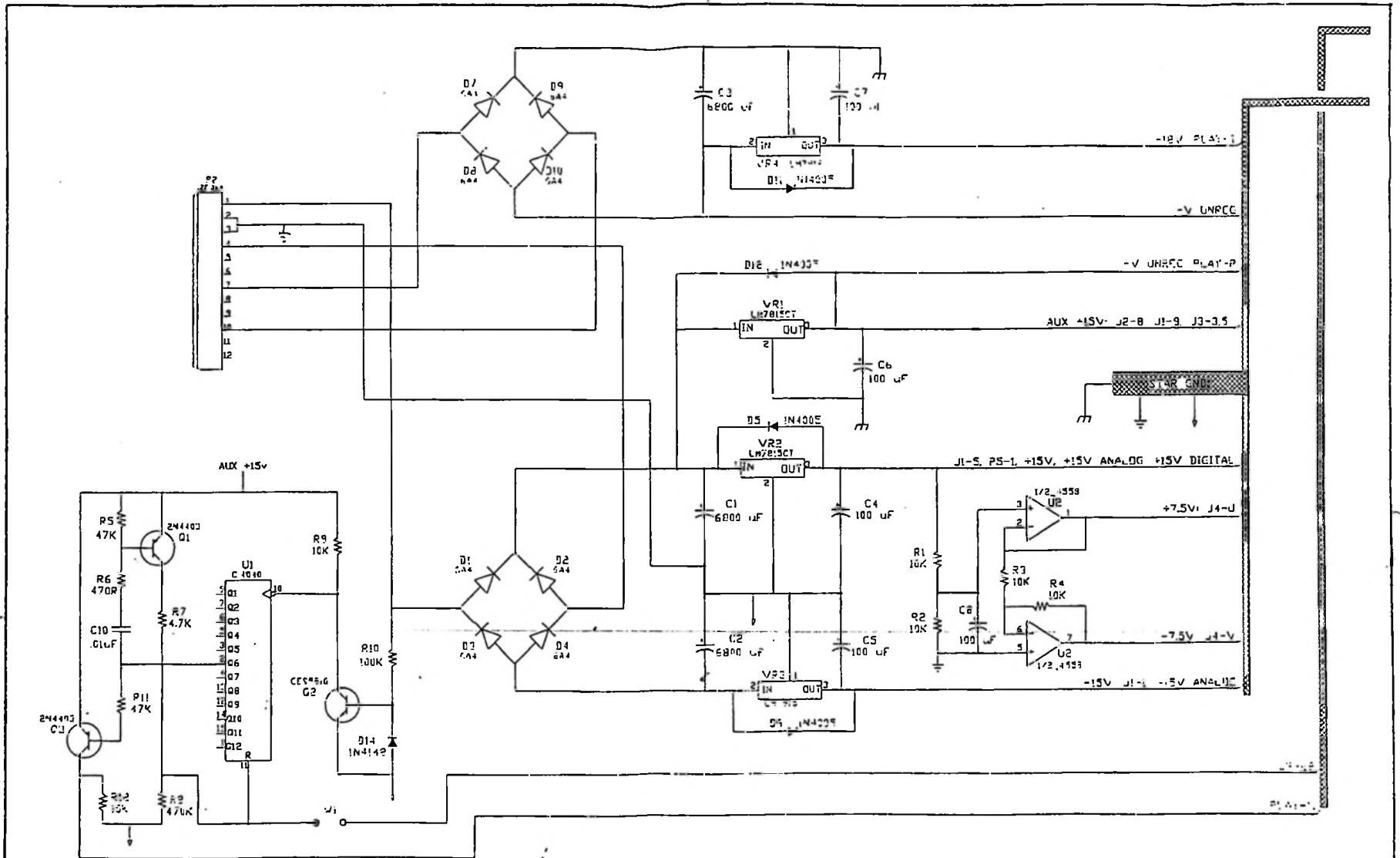

MODEL NOS	SCHEMATIC		DRG. NO.	APPR	REVISION LEVELS		FIDELIPAC CORP. MOORESTOWN, N.J.	THIS DOCUMENT CONTAINS PROPRIETARY INFORMATION OF FIDELIPAC CORPORATION AND USE, REPRODUCTION OR REPRODUCTION OF ANY PART THEREOF MAY BE MADE WITHOUT PRIOR WRITTEN PERMISSION.
	CTR10 MOTHER BOARD, DC		750-G0-105/6	MH	BILL C1 MAT C1	PC BOARD C1		
			SHEET 1 OF 3	ISSUE DATE 1/15/72	SCHEMATIC C1			

14-K (FF) (PART READY) P.2 P.2

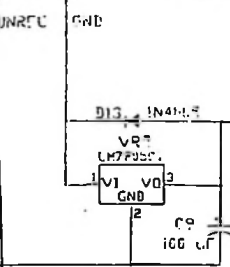

POWER CONNECTIONS NOT SHOWN GENERALLY

CONNECTION LOCATION	-V UNREG	MOTOR DRIVE -5V	-15V	GND	+5V	VCC +15V
PIN NUMBER						
U1						
U2			4	2	3	10
U3	8	16				
U4	3	16				
U5	8	16				
U6	7	14				
U7	9	16				
U8	8	16				

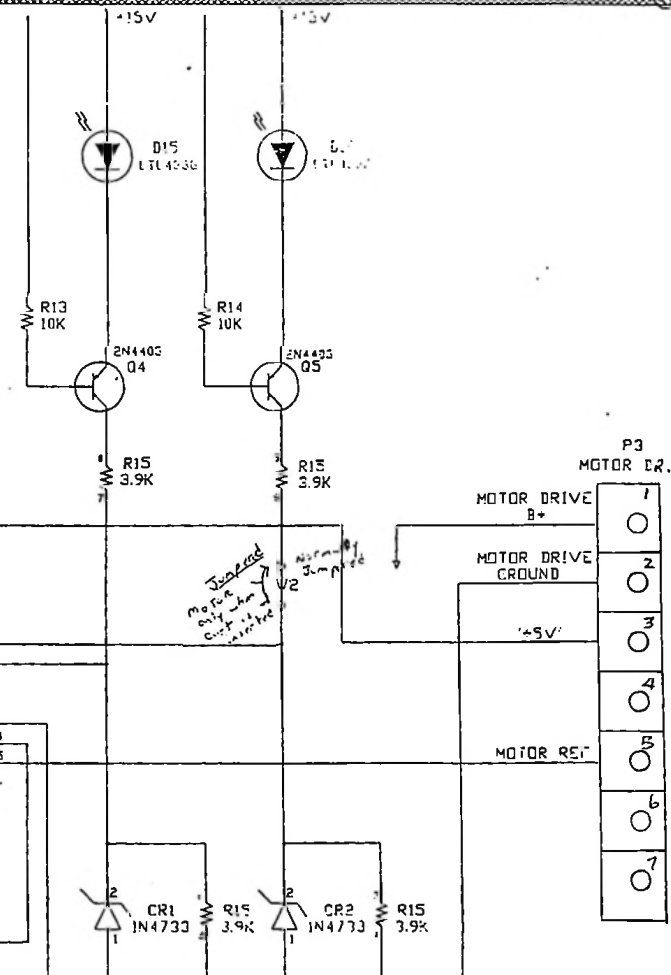
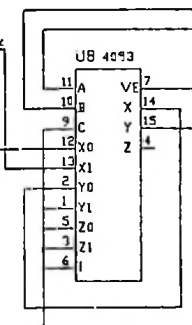
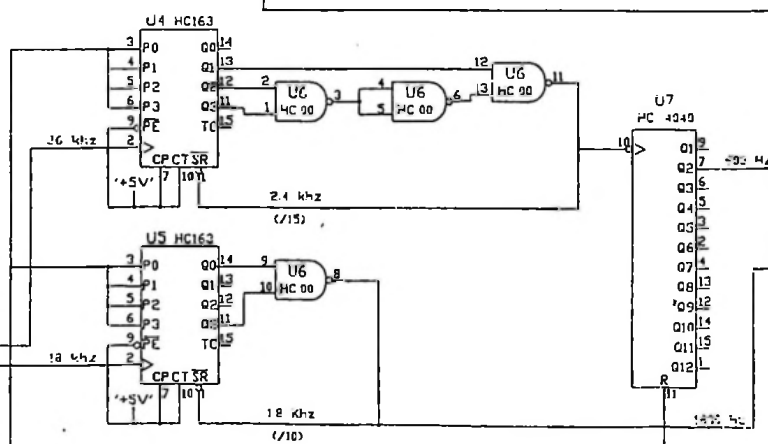
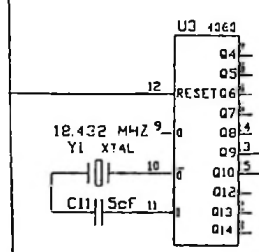
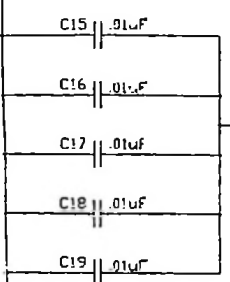



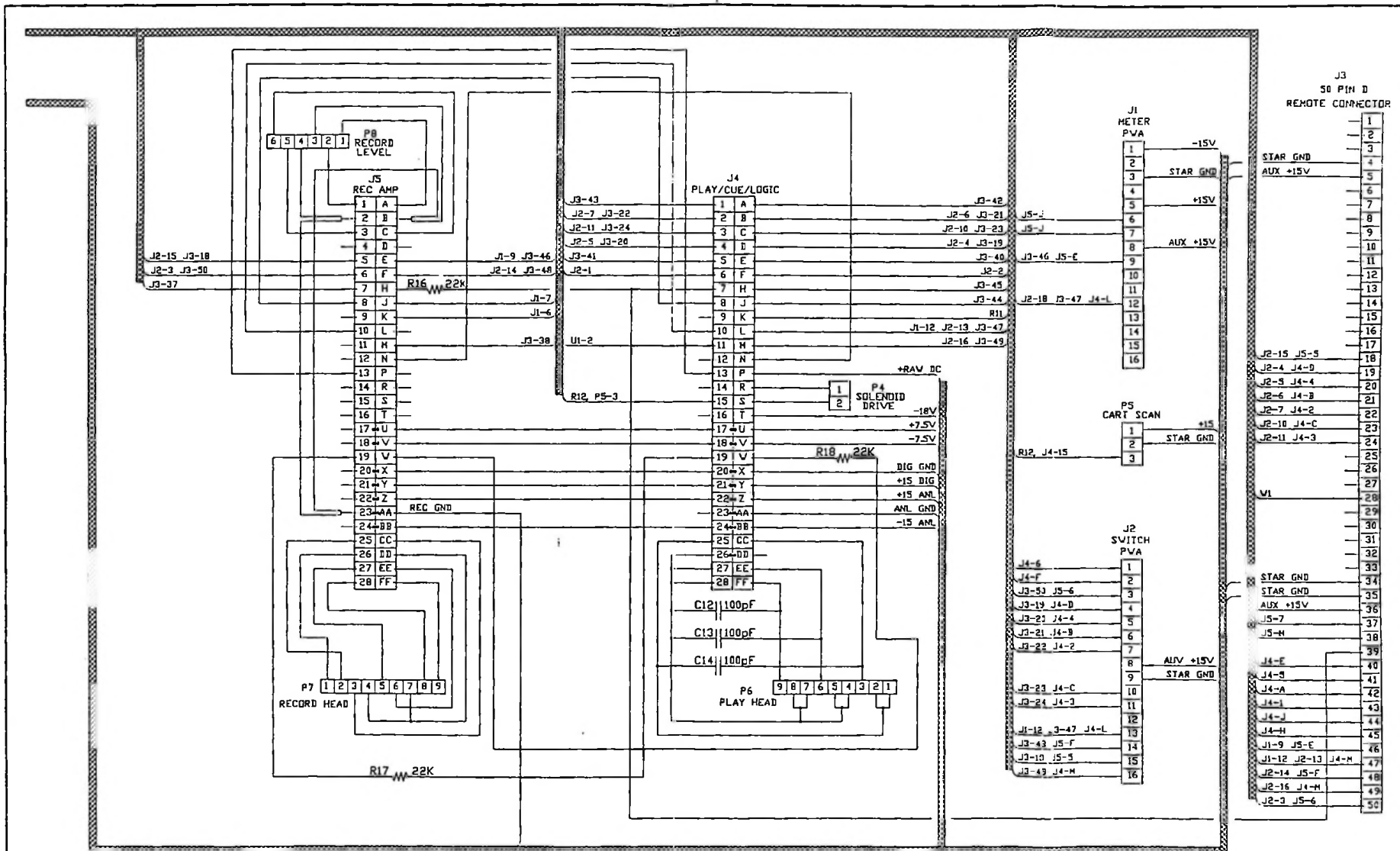

MODEL NOS.

**SCHEMATIC**  
CTR10 MOTHER BOARD, DC

DWG. NO. **750-G0-105/6**  
SHEET 3 OF 3

APPR. \_\_\_\_\_  
ISSUE DATE \_\_\_\_\_

REVISION LEVELS

BILL OF MAT. CO. \_\_\_\_\_  
SCHEMATIC G0 \_\_\_\_\_  
P.C. BOARD G0 \_\_\_\_\_

**FIDELIPAC CORP.**  
WOORESTOWN, N.J.

THIS DOCUMENT CONTAINS PROPRIETARY INFORMATION OF FIDELIPAC CORPORATION. NO USE, DISCLOSURE OR REPRODUCTION OF ANY PART THEREOF MAY BE MADE WITHOUT PRIOR WRITTEN PERMISSION.

MOTHERBOARD ASSEMBLY for CTR10 ...Page 1

FOR PARENT ITEM NUMBER 807-60-105

PART NUMBER	DESCRIPTION	QTY	SEQ	Designator
006-A6-103	.01 uF 25V D CAP	6	1	C10, 15, 16, 17, 18, 19
011-A5-688	CAP 6800 uF 50V	3	2	C1, 2, 3
011-A8-107	100 uF 25V E CAP	6	3	C4, 5, 6, 7, 8, 9
031-A2-50A	5 pf 5% CAP	1	4	C11
031-A3-221	220 pf S CAP	3	5	C12, 13, 14
110-22-103	10K 1/4W 5% CF Resistor	9	6	R1-4, R9, R11-14
110-22-104	100K 1/4W 5% CF Resistor	1	7	R10
110-22-223	22K 1/4W 5% CF Resistor	3	8	R16, 17, 18
110-22-471	470 1/4W 5% CF Resistor	1	9	R6
110-22-472	4.7K 1/4W 5% CF Resistor	1	10	R7
110-22-473	47K 1/4W 5% CF Resistor	1	11	R5
110-22-474	470K 1/4W 5% CF Resistor	1	12	R8
110-22-225	2.2 Meg 1/4W 5% CF Resistor	1		
144-11-392	Resistor net 3.9K x 4	1	13	R15
200-A0-000	1N4148 DIODE	1	14	D14
201-A0-000	1N4005 DIODE	5	15	D5, 6, 11, 12, 13
201-A0-002	6A4 DIODE	4	16	D1-4
204-A0-002	1N4733A DIODE	2	17	CR1, 2
210-A0-002	MPS2222 Transistor	1	18	Q2
210-A0-003	2N4403 Transistor	2	19	Q1, Q3
230-A0-010	RC4558 IC	1	20	U2
230-A0-406	HC4053 IC	1	21	U8
231-A0-023	4040 IC	1	22	U1
231-A0-403	74HC00 IC	1	23	U6
231-A0-404	74HC4040 IC	1	24	U7
231-A0-405	74HC4060 IC	1	25	U3
231-A0-412	74HC163 IC	2	26	U4, 5
250-A0-298	GREEN LED	1	27	D15
250-A0-299	RED LED	1	28	D16
3700003	MC78M05CT REGULATOR	1	29	VR5
384-A0-000	CRYSTAL 18.432MHZ HC18U	1	30	Y1
407-60-105	PCB. MOTHER BD CTR10 DC	1	31	PCB
410-A0-001	8 PIN SOCKET DIP	1	32	SU2
410-A0-002	14 PIN SOCKET DIP	1	33	SU6
410-A0-003	16 PIN SOCKET DIP	8	34	J1-2, SU1, 3-5, 7, 8
410-A0-009	Transistor SOCKET	4	35	SVR1-4
412-A0-001	EDGE CONNECTOR 28 POS DUAL	2	36	J4, 5
416-A0-006	12 PIN MR HEADER	1	37	P2
416-A0-008	MTA 100 2 POS HEADER	1	38	P4
416-A0-009	MTA 100 3 POS HEADER	1	39	P5
416-A0-011	MTA 100 6 POS HEADER	1	40	P8
416-A0-012	MTA 100 7 POS HEADER	1	41	P3

MOTHERBOARD ASSEMBLY for CTR10 - Page 2

FOR PARENT ITEM NUMBER 807-60-105

PART NUMBER	DESCRIPTION	QTY	SEQ	Designator
416-A0-016	.079 9 POS HEADER	2	42	P6, 7
418-A0-003	50 PIN D RT ANGLE RECEPTACLE	1	43	J3
4700036	MPS-8599 Transistor	2	44	Q4, 5
525-A0-105	MOTOR BD SHIELD CTR10	1	45	SHLD1
541-A0-050	HEAT SINK T0220 BD MT Recessed	1	46	HS1
601-20-440	NUT HEX 4-40 STEEL PLATE	2	47	M8, 9
601-20-632	NUT HEX 6-32 STEEL PLATE	1	48	M3
60C-11-400	LOCK WASHER I.T., #4	2	49	M6, 7
60C-11-600	LOCK WASHER I.T., #6	1	50	M2
621-04-440	SCREW P.H. PHIL 4-40 X 1/4 SP	2	51	M4, 5
621-04-632	SCREW P.H. PHIL 632 X 1/4 PL	1	52	M1

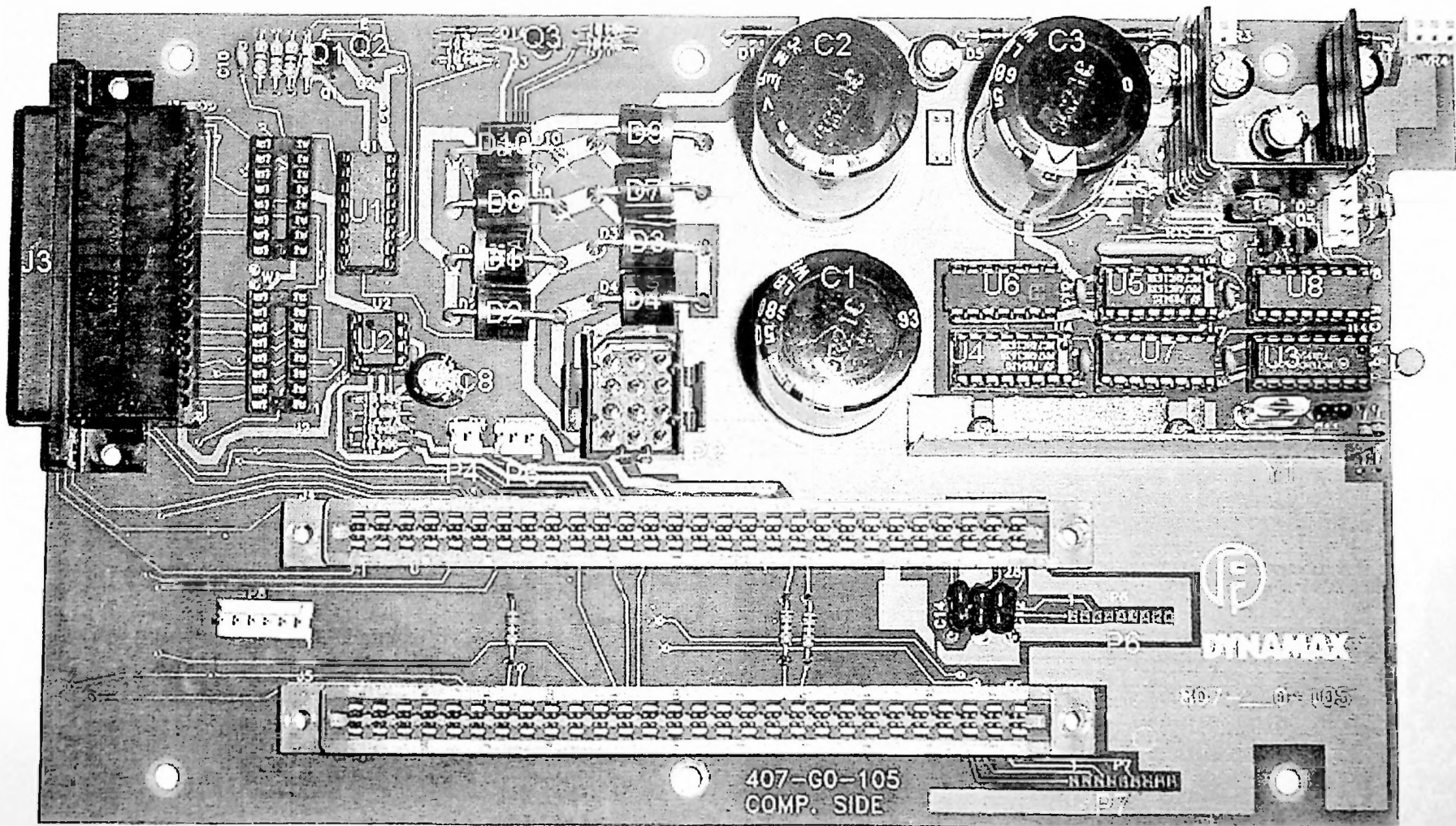

407-60-105  
COMP. SIDE

  
**DYNAMAX**

307-105 (105)

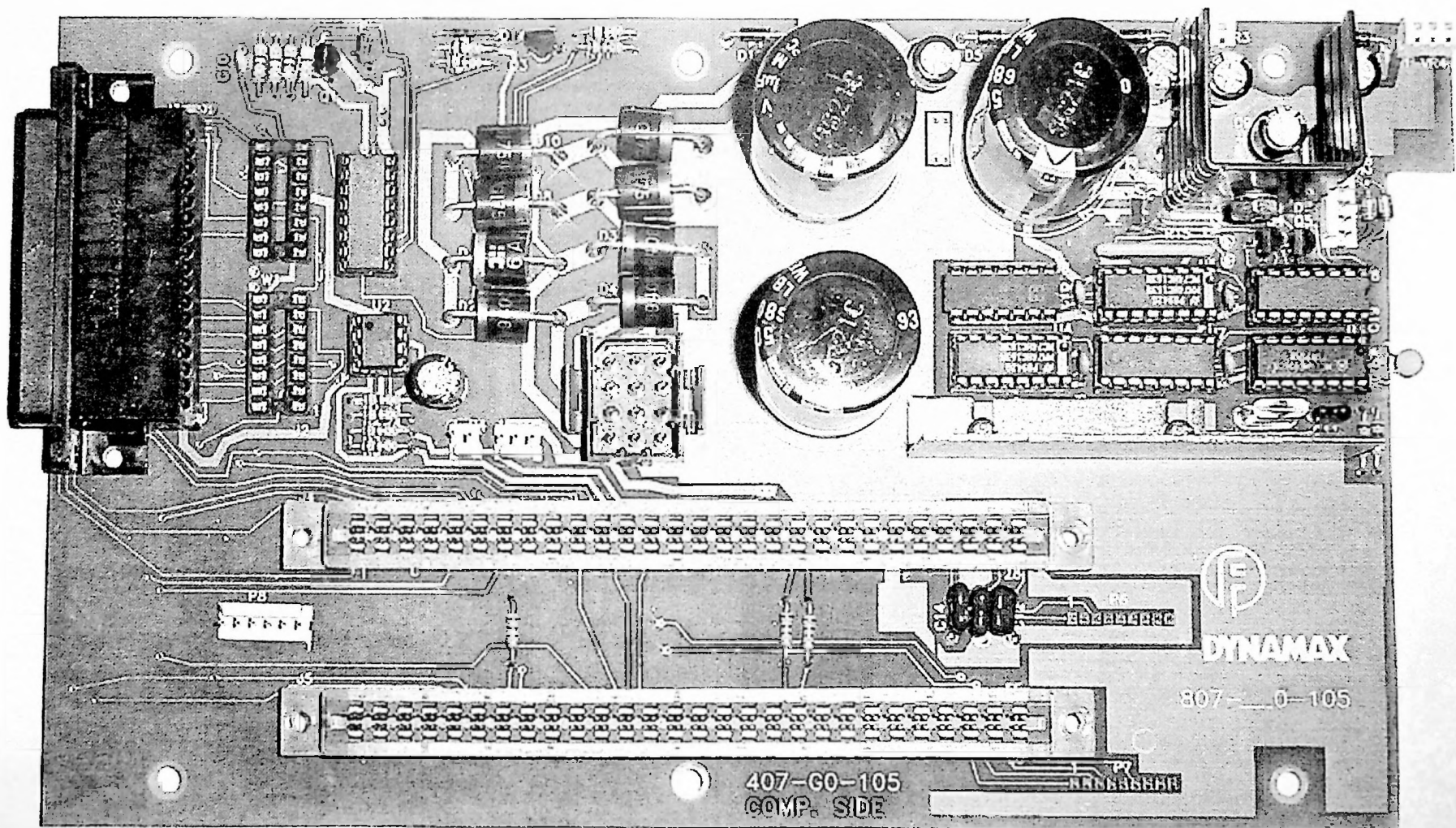

407-60-105  
COMP. SIDE



DYNAMAX

807-0-105

FOR USE WITH TOROIDAL TRANSFORMER  
ASSEMBLY #827-D0-023

1. D7-D10 DELETED  
&
2. JUMPER MADE AT  
DOTTED LINE

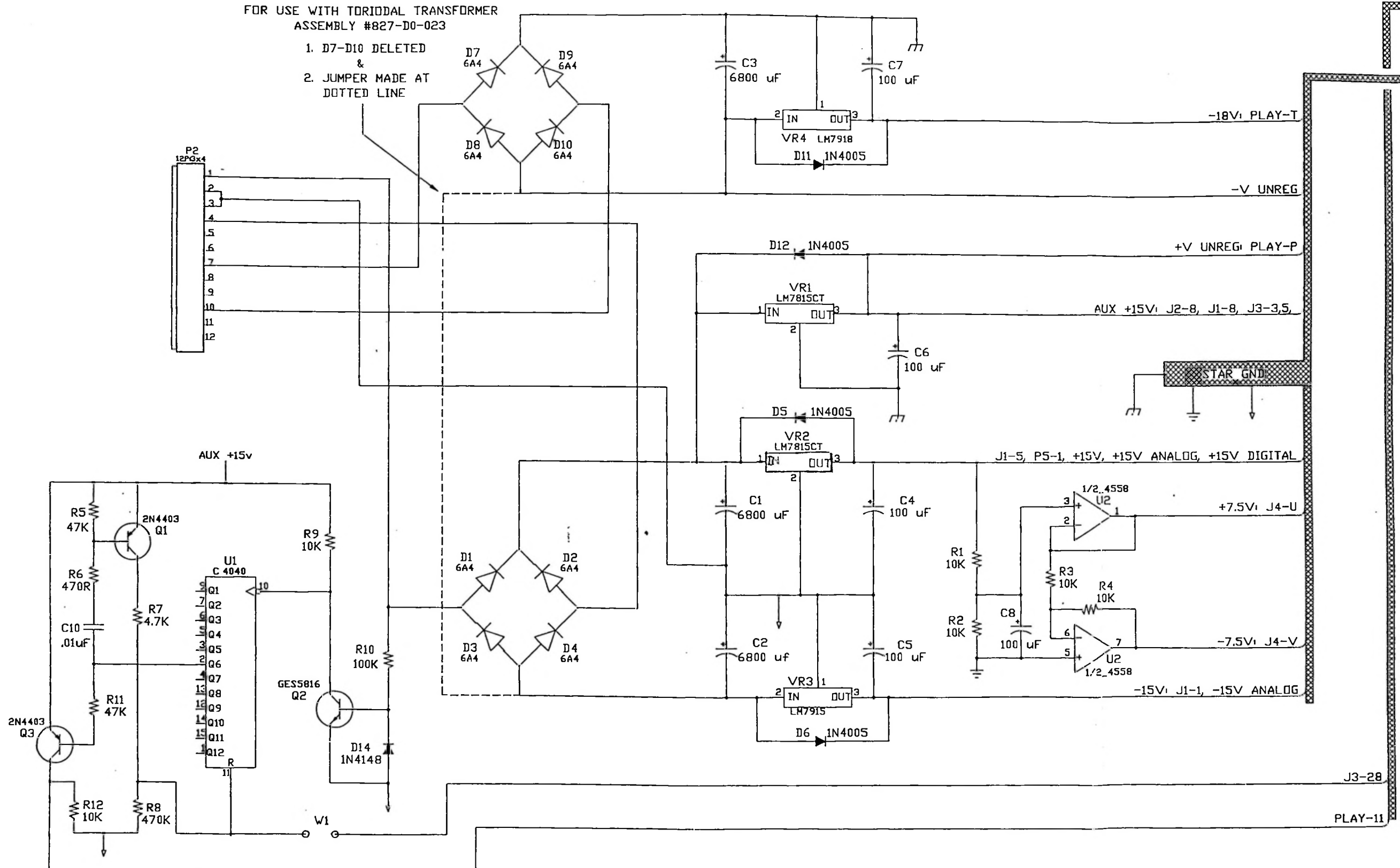

MODEL NOS.  
CTR10 MOTHER BOARD, DC

**SCHEMATIC**  
CTR10 MOTHER BOARD, DC

DRG. NO.  
750-G0-105/6  
SHEET 1 OF 3

APPR.  
ISSUE DATE

REVISION LEVELS  
BILL OF MAT. CO  
SCHEMATIC G0  
P.C. BOARD G0

**FIDELIPAC CORP.**  
MOORESTOWN, N.J.

THIS DOCUMENT CONTAINS PROPRIETARY INFORMATION OF FIDELIPAC CORPORATION. NO USE, DISCLOSURE OR REPRODUCTION OF ANY PART THEREOF MAY BE MADE WITHOUT PRIOR WRITTEN PERMISSION.

-V UNREG GND

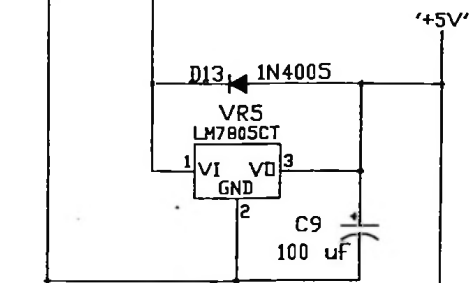

POWER CONNECTIONS NOT SHOWN SCHEMATICALLY

CONNECTION LOCATION	-V UNREG	MOTOR DRIVE '+5V'	-15V	GND	+15V	AUX +15V
	PIN NUMBER					
U1				8		16
U2			4		8	
U3	8	16				
U4	8	16				
U5	8	16				
U6	7	14				
U7	8	16				
U8	8	16				

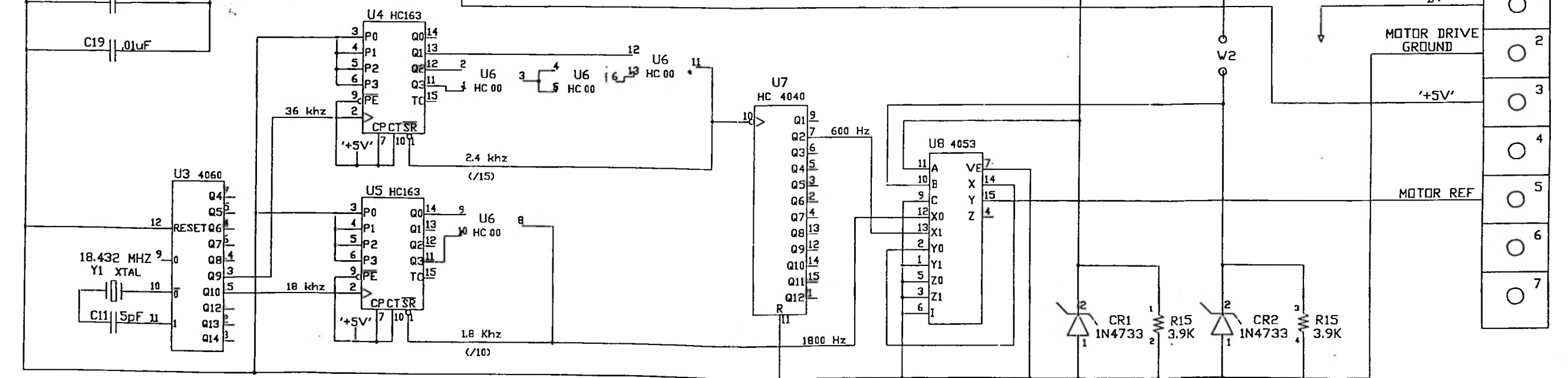
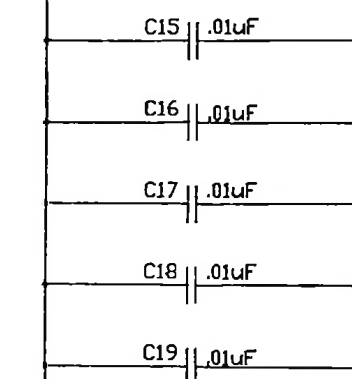

J4-K (FF) (CART R12, P5-3) READY

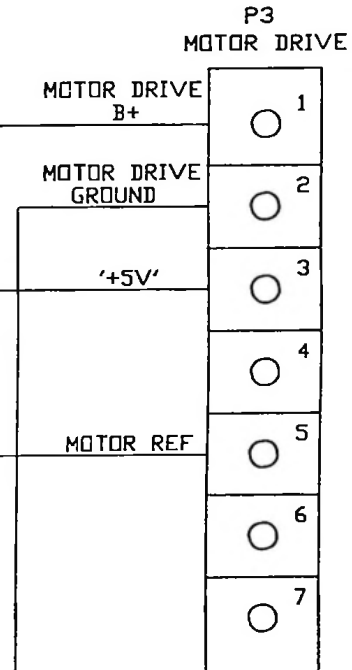
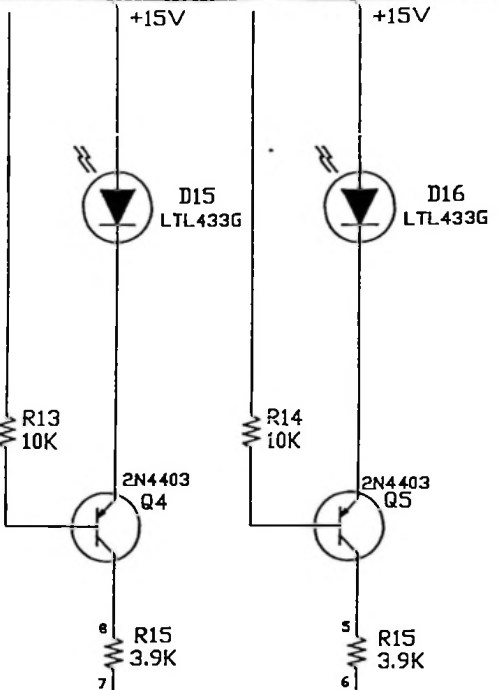

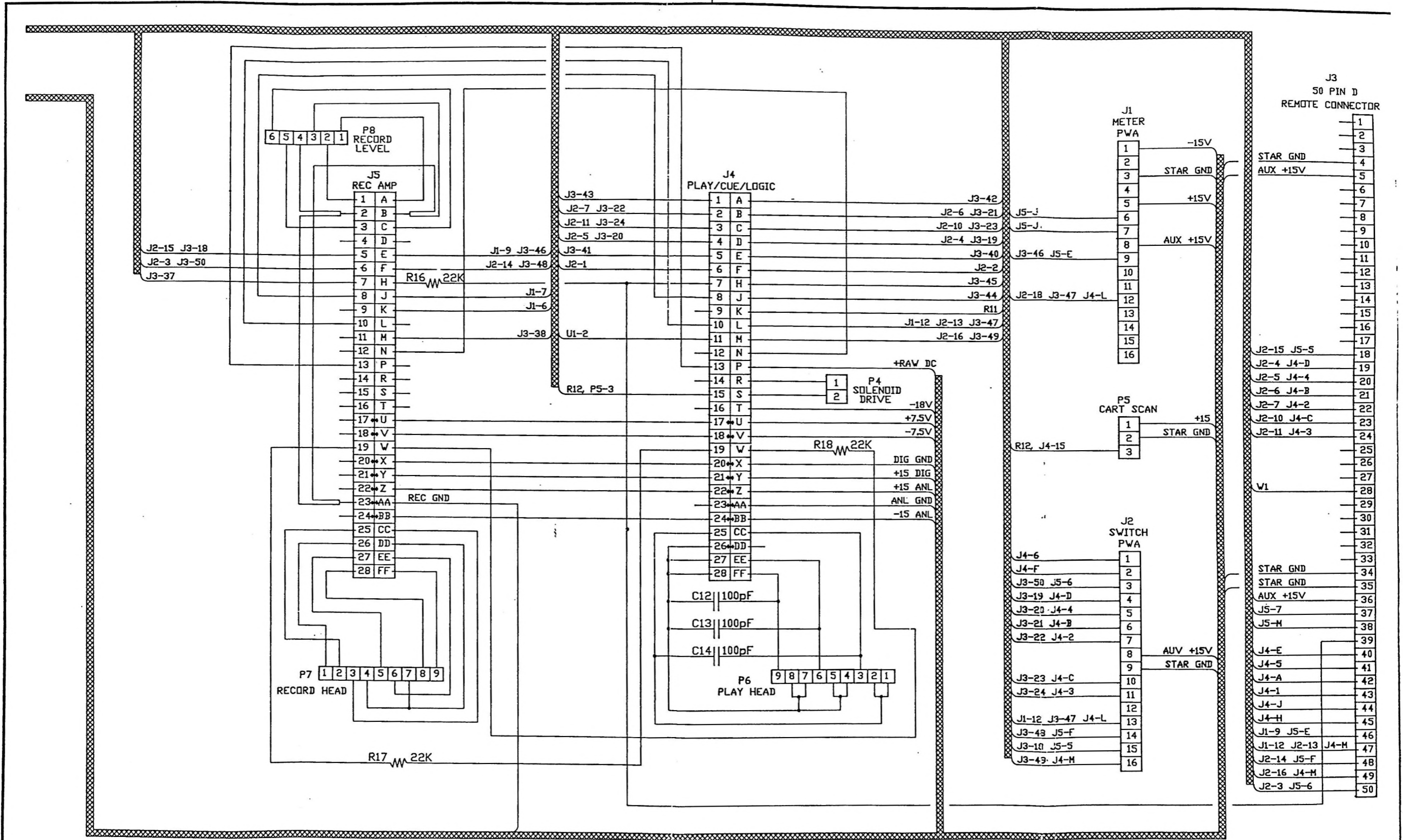



526-0023-004 DELTA

**PART INSPECTION CARD**

**SAMPLE CODE LEGEND**

Vendor: Sedlbauer

Yellow: \_\_\_\_\_

Part #: 81-8000-3799-6 Rev.

Orange: \_\_\_\_\_

Description: Transformer Shielded Toroid

Red: \_\_\_\_\_

Green: \_\_\_\_\_

Record new shipments only! No reworks, returns sorts, etc.

T1, T2 and B items are not eligible for skip-lot.

\_\_\_\_\_ Refer to manual if revision changes. \_\_\_\_\_

0V braun 1  
Einzelteilen 30/g  
120V grau 2

- 13 or
- 22 schw
- 16 or
- 14 rot
- 26 gelb
- 21 rot

*11,15 - 11,84*  
10.5V/1.80A U0=11.5V

0V Sammelteuelle 20/g  
10.5V/1.80A U0=11.5V



0V vio 3  
Einzelteilen 30/g  
120V blau 2

Zwisol  
19.0V/0.53A U0=21.3V

0V Sammelteuelle 20/g  
19.0V/0.53A U0=21.3V

OK-D-R-S

*Steve Cant*

FOR USE WITH TOROIDAL TRANSFORMER  
ASSEMBLY #827-D0-023

1. D7-D10 DELETED  
&
2. JUMPER MADE AT  
DOTTED LINE

*IR = 2V FWB  
5V HwB*

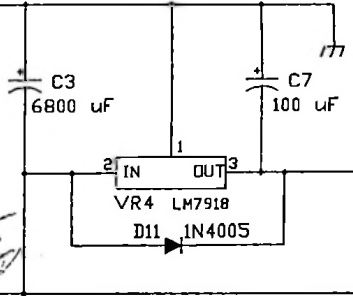
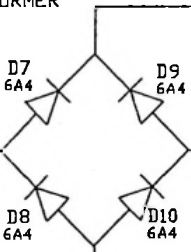

*-35  
-30*

*35V*

*-35*

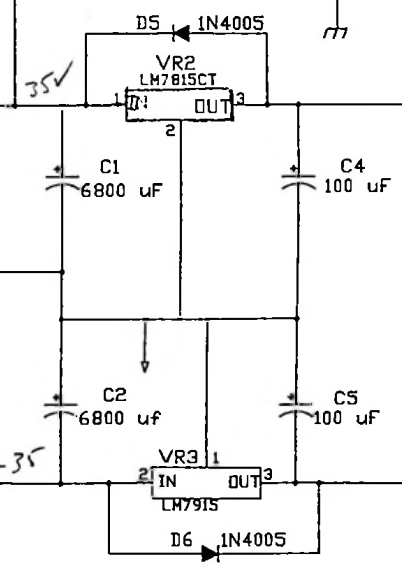
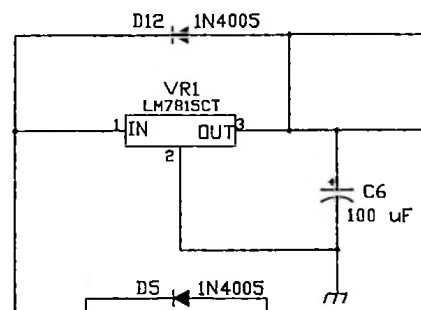
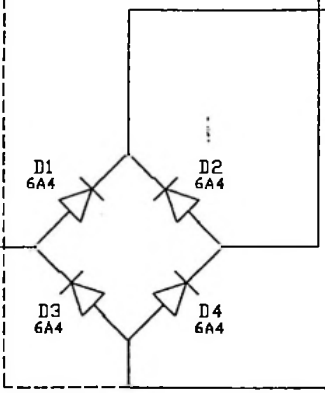

J1-S, P5-1, +

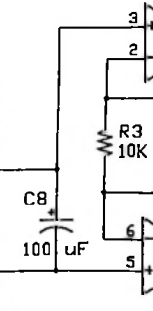
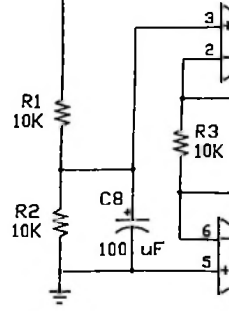
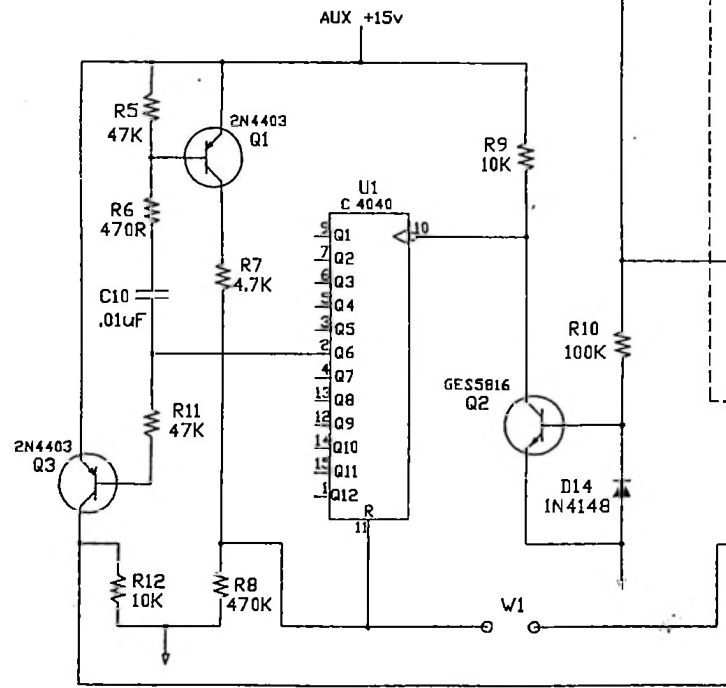

# DAREN TRANSFORMER 110V OPERATION

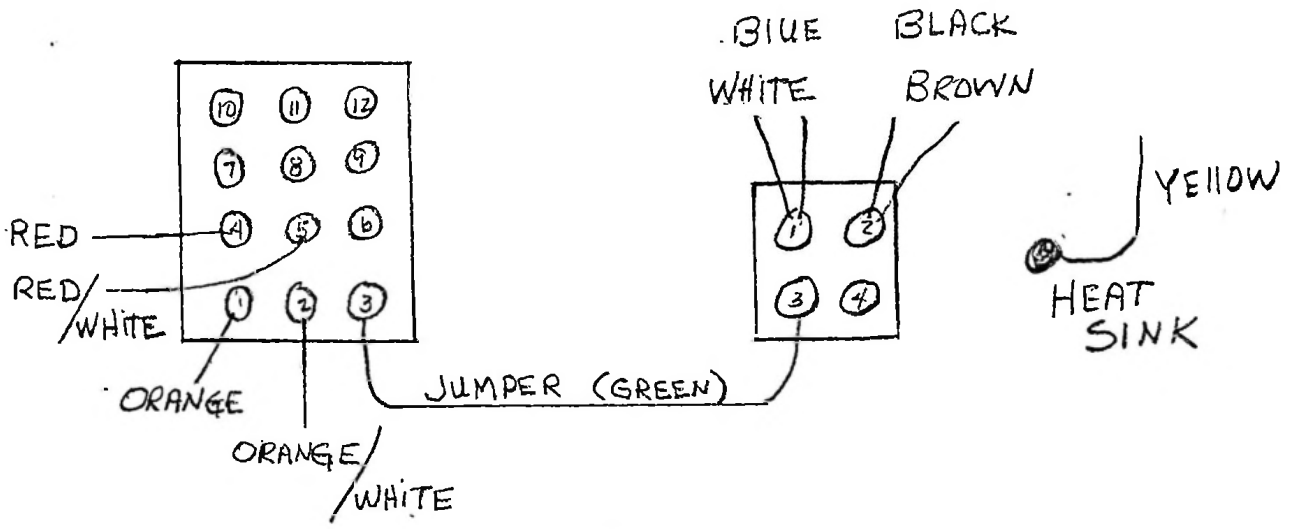

# DAREN TRANSFORMER 220V OPERATION

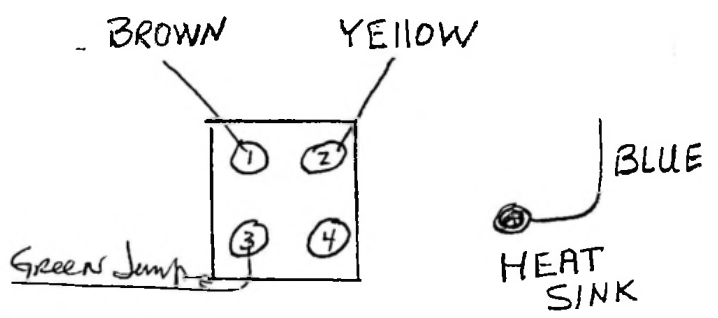

# DAREN TRANSFORMER 110V OPERATION

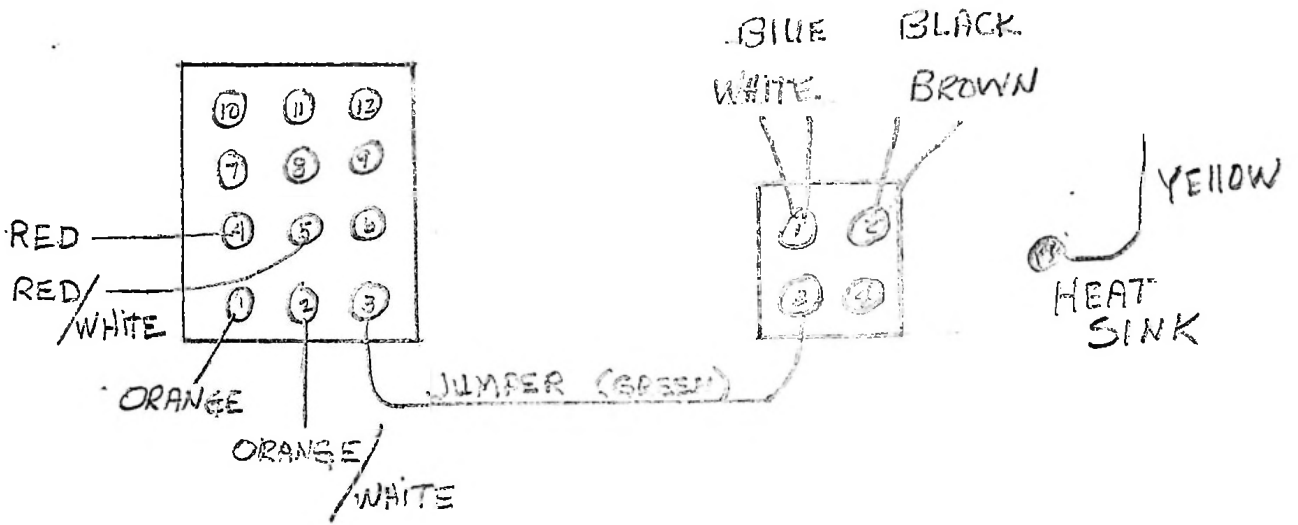

# DAREN TRANSFORMER 220V OPERATION

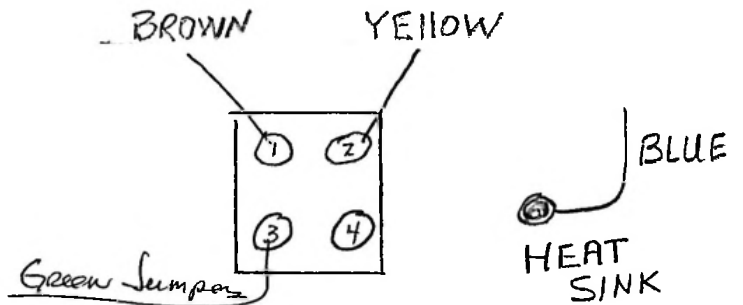

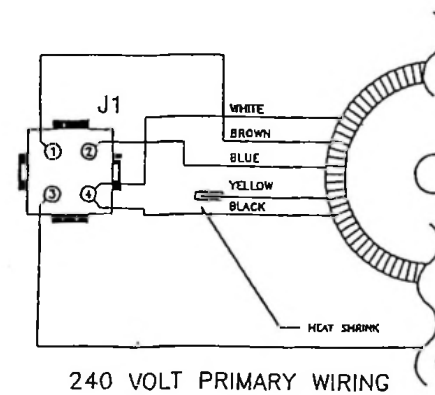
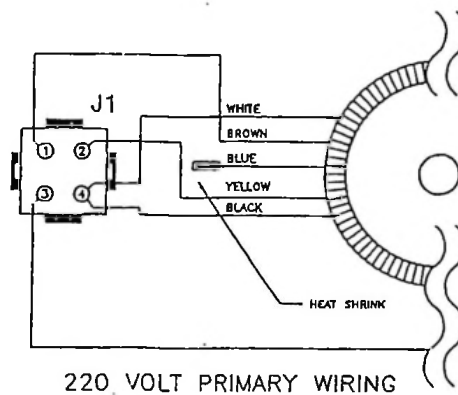
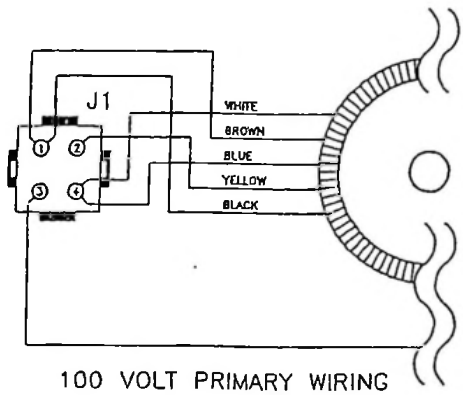
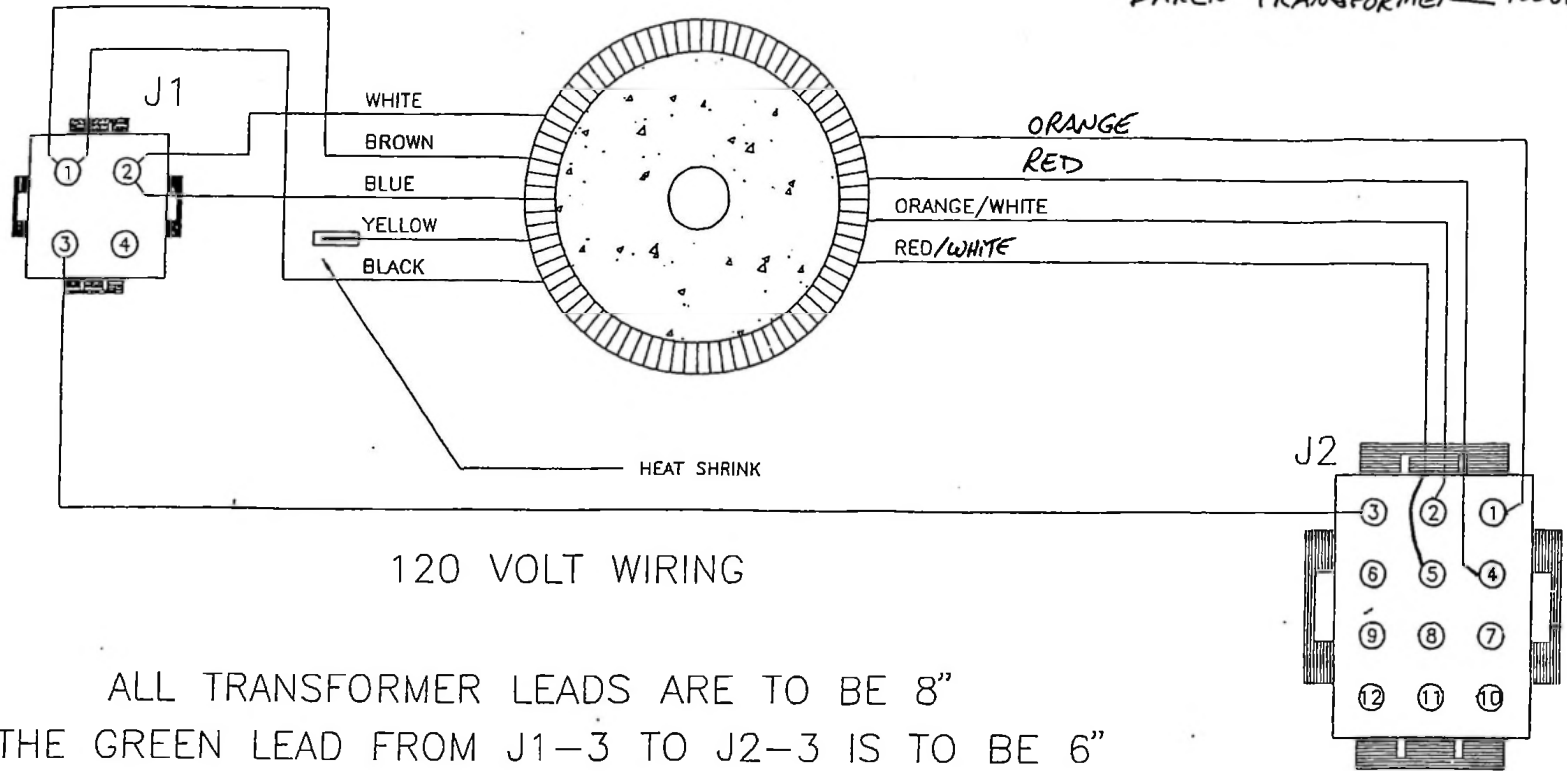

MODEL NOS.	SCHEMATIC		DWG. NO.	APPR.	REVISION LEVELS		FIDELIPAC CORP. MOORESTOWN, N.J.	THIS DOCUMENT IS PROPERTY OF FIDELIPAC CORP. REPRODUCTION OF WITHOUT PRIOR WR
	DC10 TORIOD TRANSFORMER ASSEMBLY		827-D0-023		BILL OF MAT. XX	P. C BOARD XX		
SHEET 1 OF 1			ISSUE DATE 11/22/92	SCHEMATIC XX				

12/9/00

120V



Pri. 1

0V

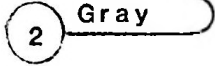

120V



Pri. 2

0V

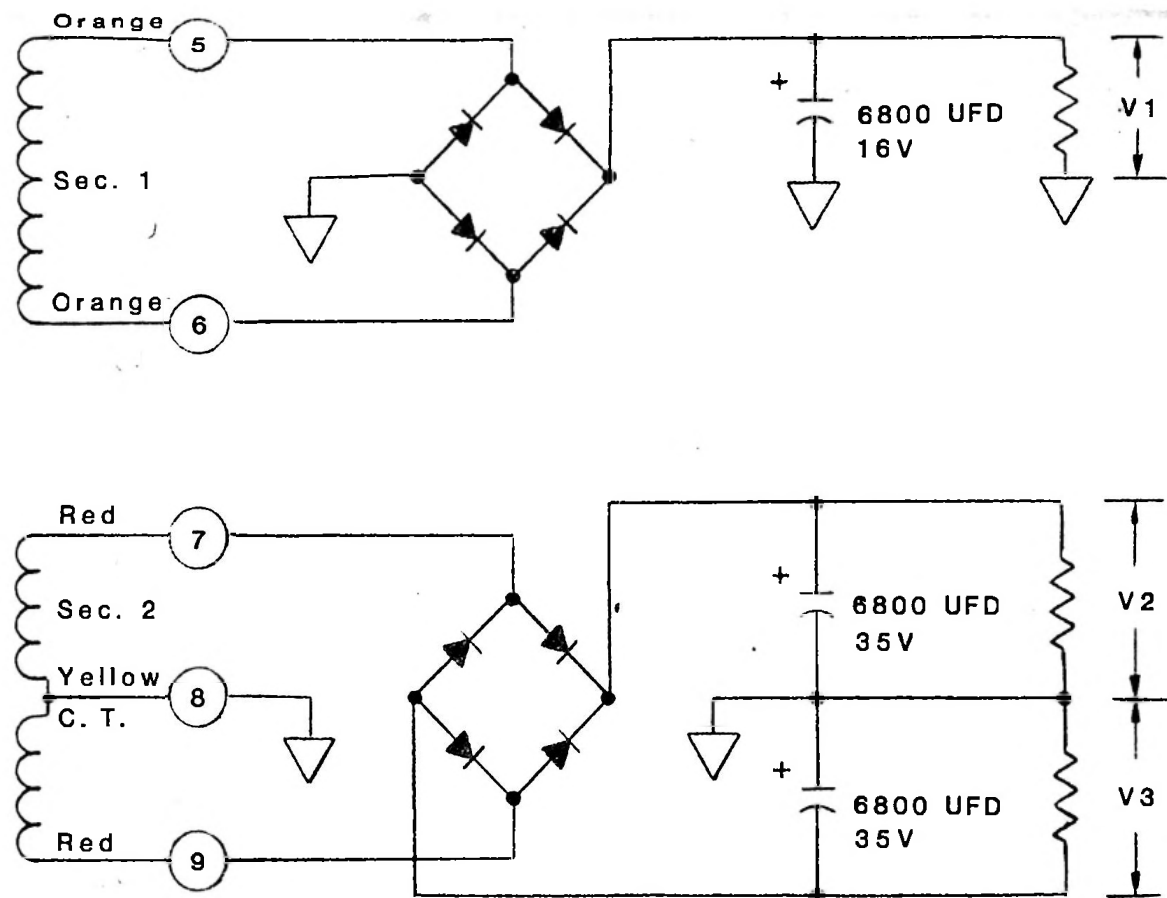

DC voltages and currents at 25 degree C

	V1	V2	V3
Minimum load	+13.5V Max. at 0.1A	+26.0V Max. at 0.1A	-26.0V Max. at 0.1A
Maximum load	+9.0V Min. at 1.3A	+20.5V Min. at 1.0A	-20.5V Min. at 1.5A

*Blue Body*

Primaries connected for 120V or 240V, 50/60 Hz.

526-0022

81-1000-3798-8

3798-8

REVISIONS			
REV	DESCRIPTION	DATE	APPROVED
D	RECORD CHANGE	6/18/91	

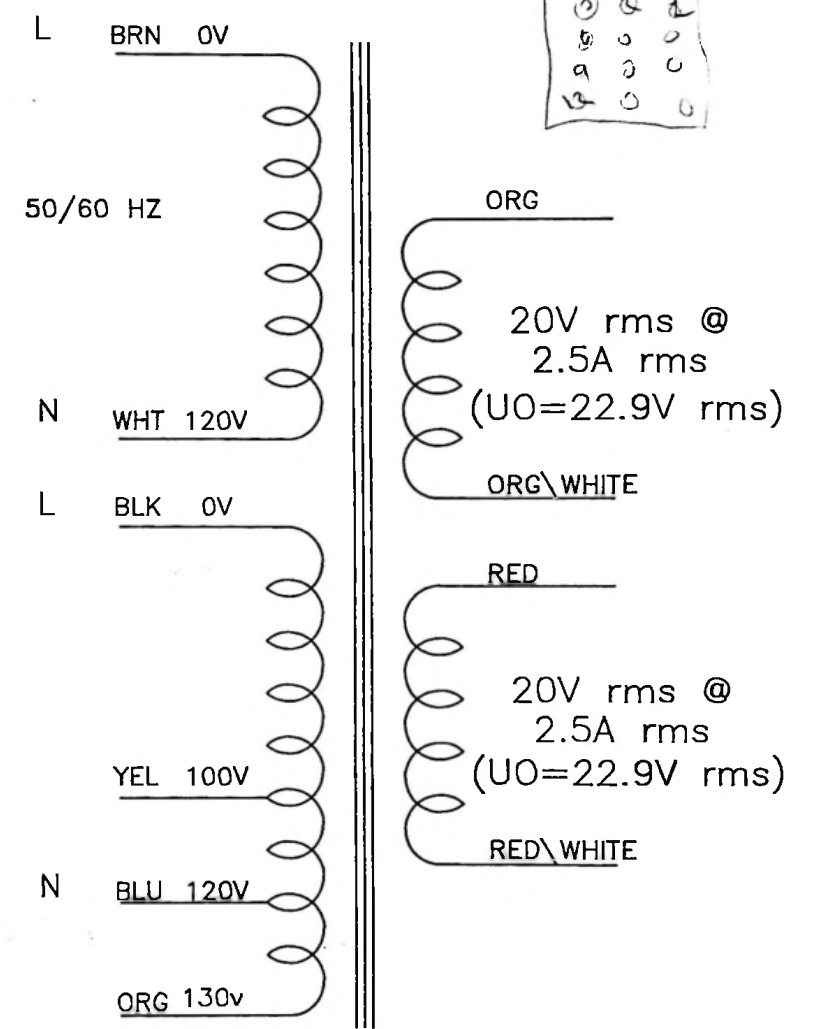
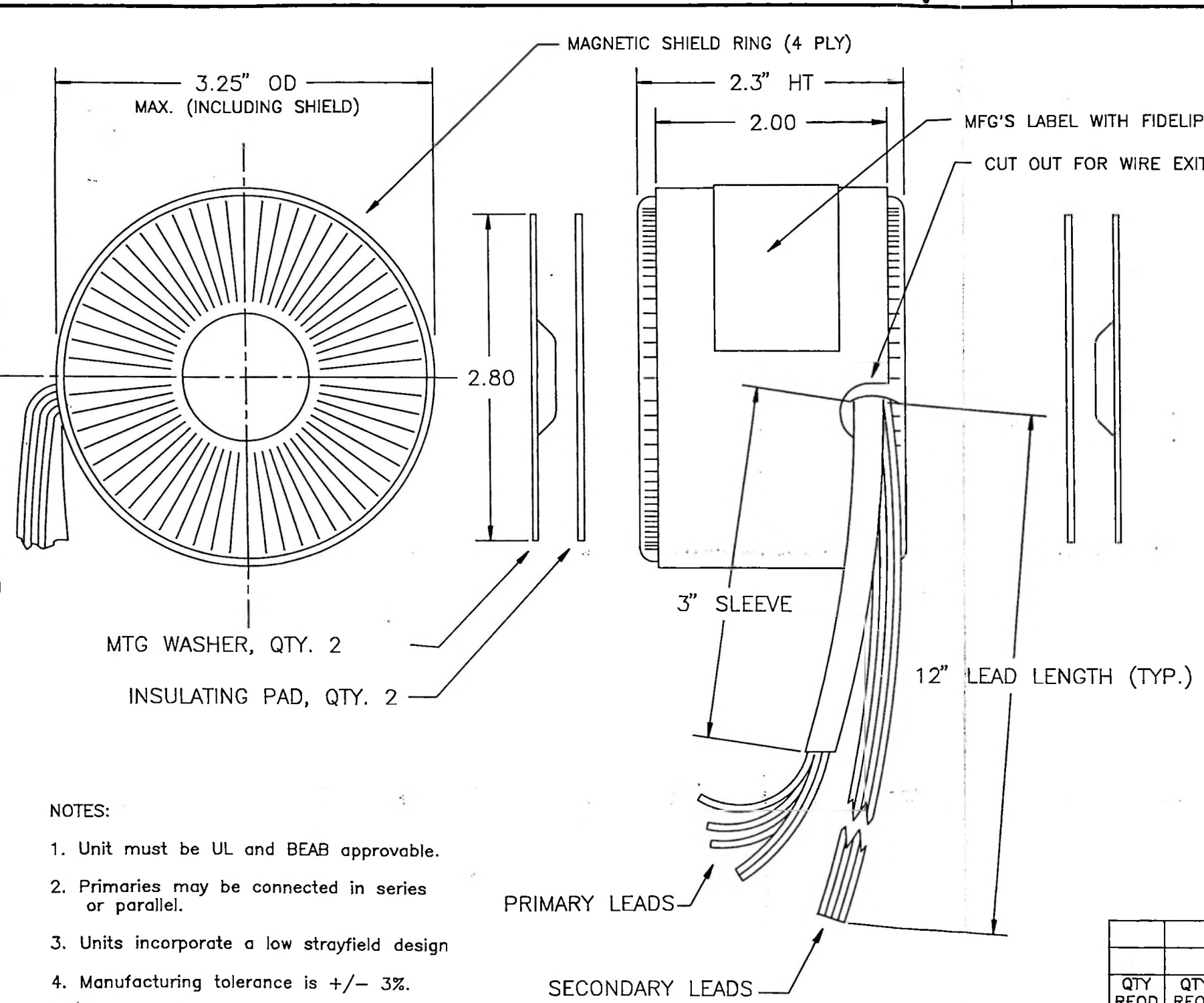

- NOTES:
1. Unit must be UL and BEAB approvable.
  2. Primaries may be connected in series or parallel.
  3. Units incorporate a low strayfield design
  4. Manufacturing tolerance is +/- 3%.
  5. Exact primary currents, no-load loss, no-load current, and full load efficiency to be documented by vendor.

QTY REQD	QTY REQD	QTY REQD	DRAWING NO.	DESCRIPTION

PARTS LIST

MATERIAL:	REMOVE ALL BURRS BREAK SHARP EDGES .015 ± .010		UNLESS OTHERWISE SPECIFIED DIMENSIONS ARE IN INCHES AND INCLUDE THICKNESS OF PLATING	CONTRACT NO.	<b>FIDELIPAC CORP.</b> MOORESTOWN, N.J.
FINISH:	NEXT ASSY.	USED ON	TOLERANCES ON: BASIC DIM'S    2 PLACE DECIMAL    3 PLACE DECIMAL UP TO 8        ±.02                    ±.005 ABOVE 8 TO 24   ±.03                    ±.010 ABOVE 24       ±.06                    ±.015 ANGULAR DIM. ± 1/2°	DRAWN BY T.J.W.    DATE 4/18/90 CHECKED BY APPROVED BY	
					SCALE 1:1    SHEET 1 OF 1

311AP402

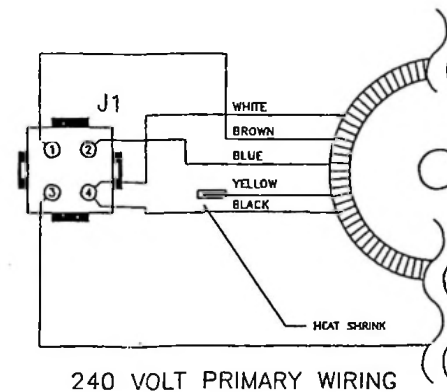
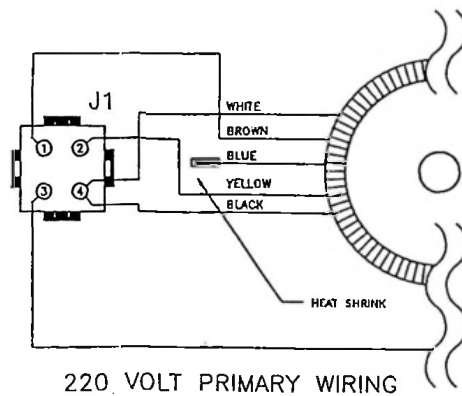
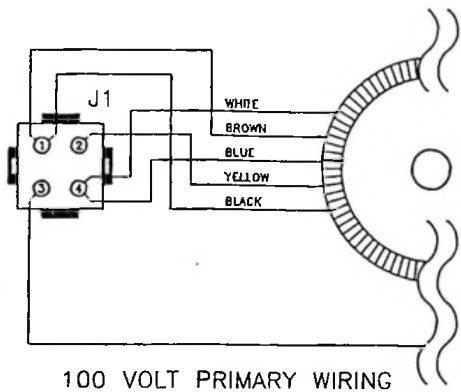
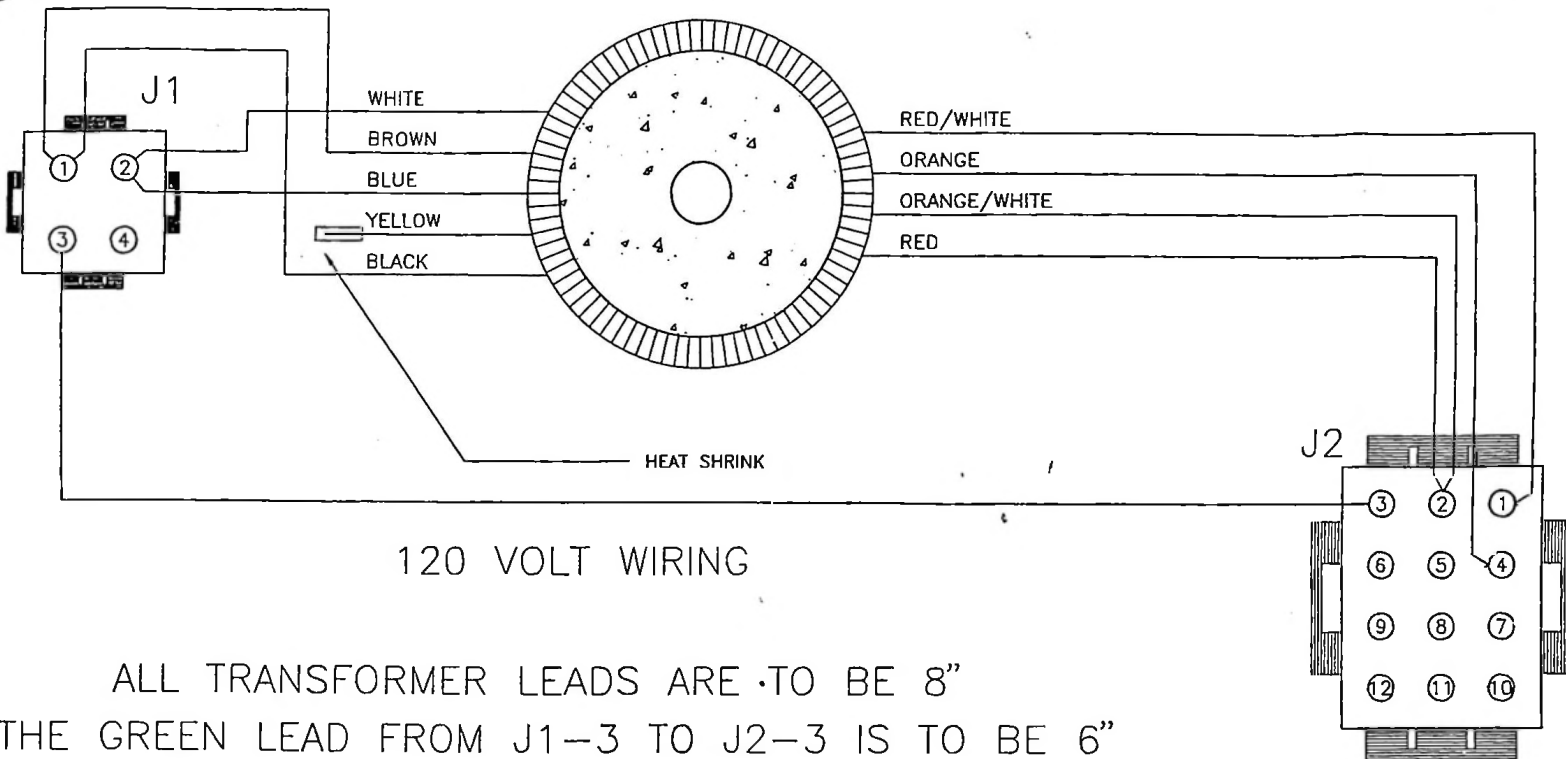

MODEL NOS.	SCHEMATIC DC10 TORIOD TRANSFORMER ASSEMBLY	DWG. NO.	827-D0-023	APPR.	REVISION LEVELS		FIDELIPAC CORP. MOORESTOWN, N.J.	THIS DOCUMENT IS THE PROPERTY OF FIDELIPAC CORP. REPRODUCTION OF WITHOUT PRIOR WRITING IS PROHIBITED.	
		SHEET	1	OF	1	ISSUE DATE			11/22/92



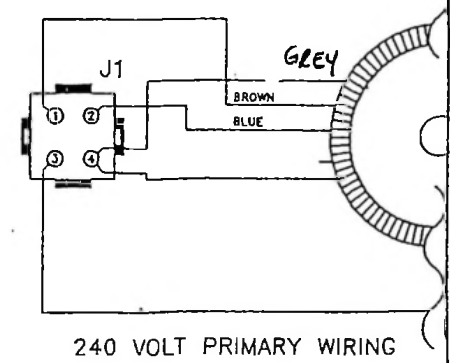
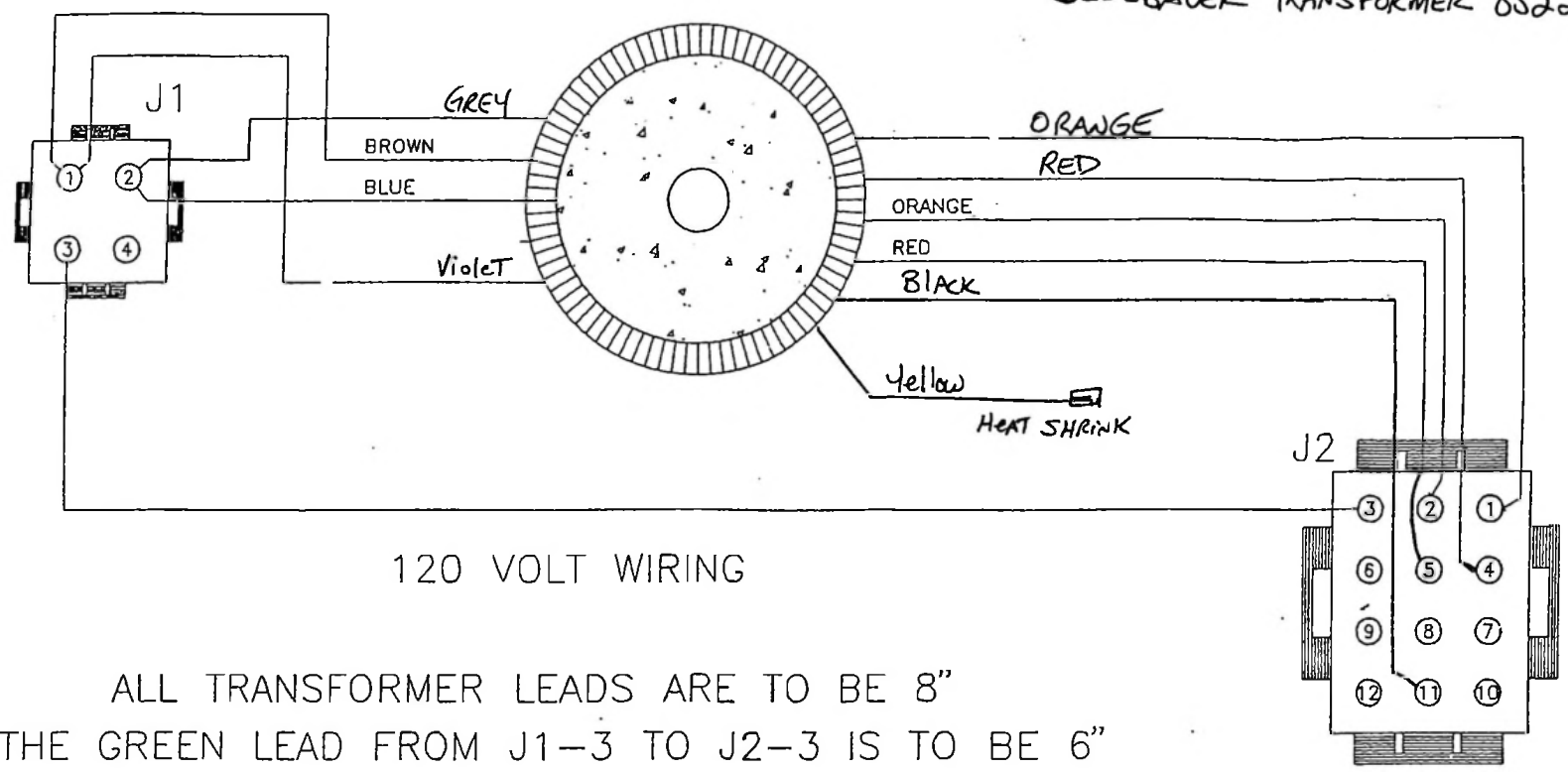

MODEL NOS.	SCHEMATIC		OWG. NO.	APPR.	REVISION LEVELS		FIDELIPAC CORP. MOORESTOWN, N.J.	THIS DOCUMENT IS OF FIDELIPAC CORP. REPRODUCTION OF WITHOUT PRIOR WR
	DC10 TORIOD TRANSFORMER ASSEMBLY		827-D0-023		BILL OF MAT. XX			
	SHEET	OF	ISSUE DATE 11/22/92	SHEMATIC XX	P.C.BOARD XX			

12/9/00

# DAREN TRANSFORMER 110V OPERATION

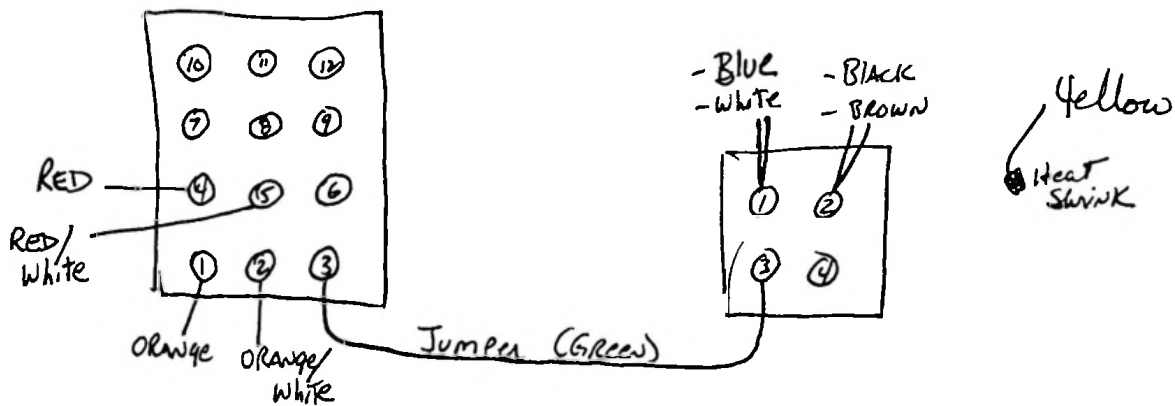

# DAREN TRANSFORMER 200V

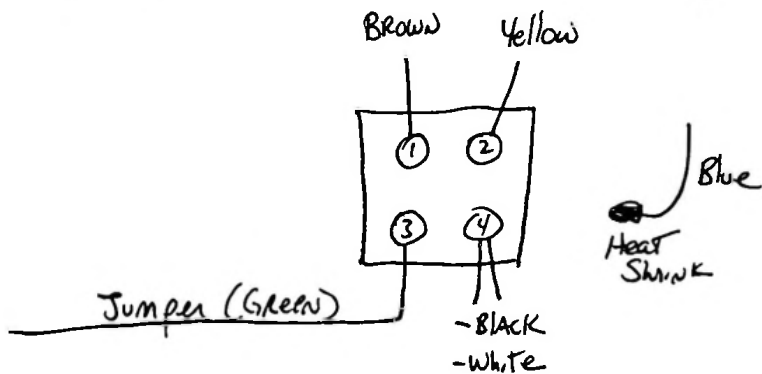

# DAREN TRANSFORMER 110V OPERATION

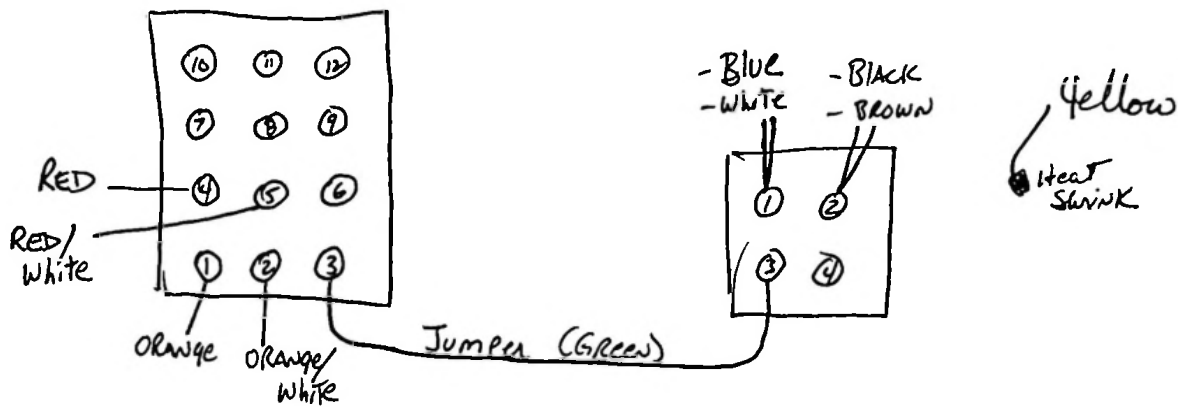

# DAREN TRANSFORMER 220V

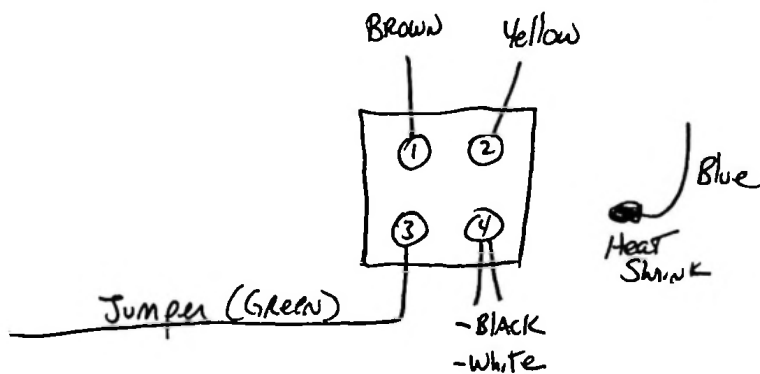

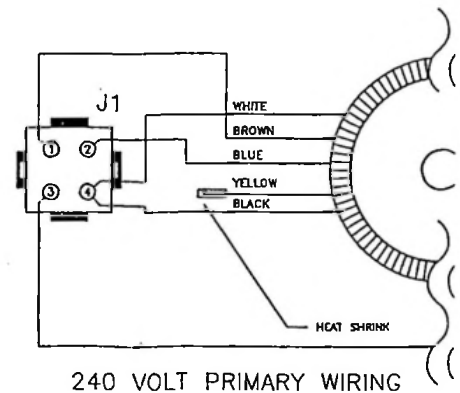
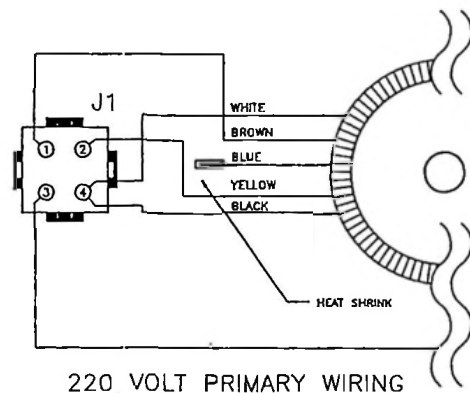
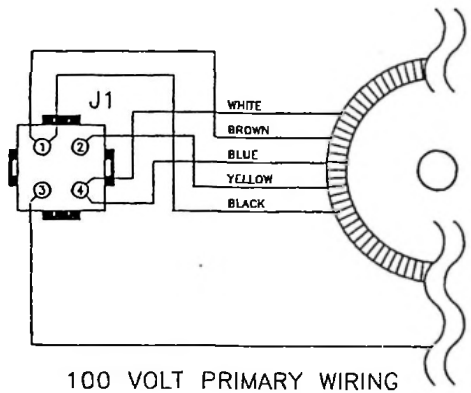
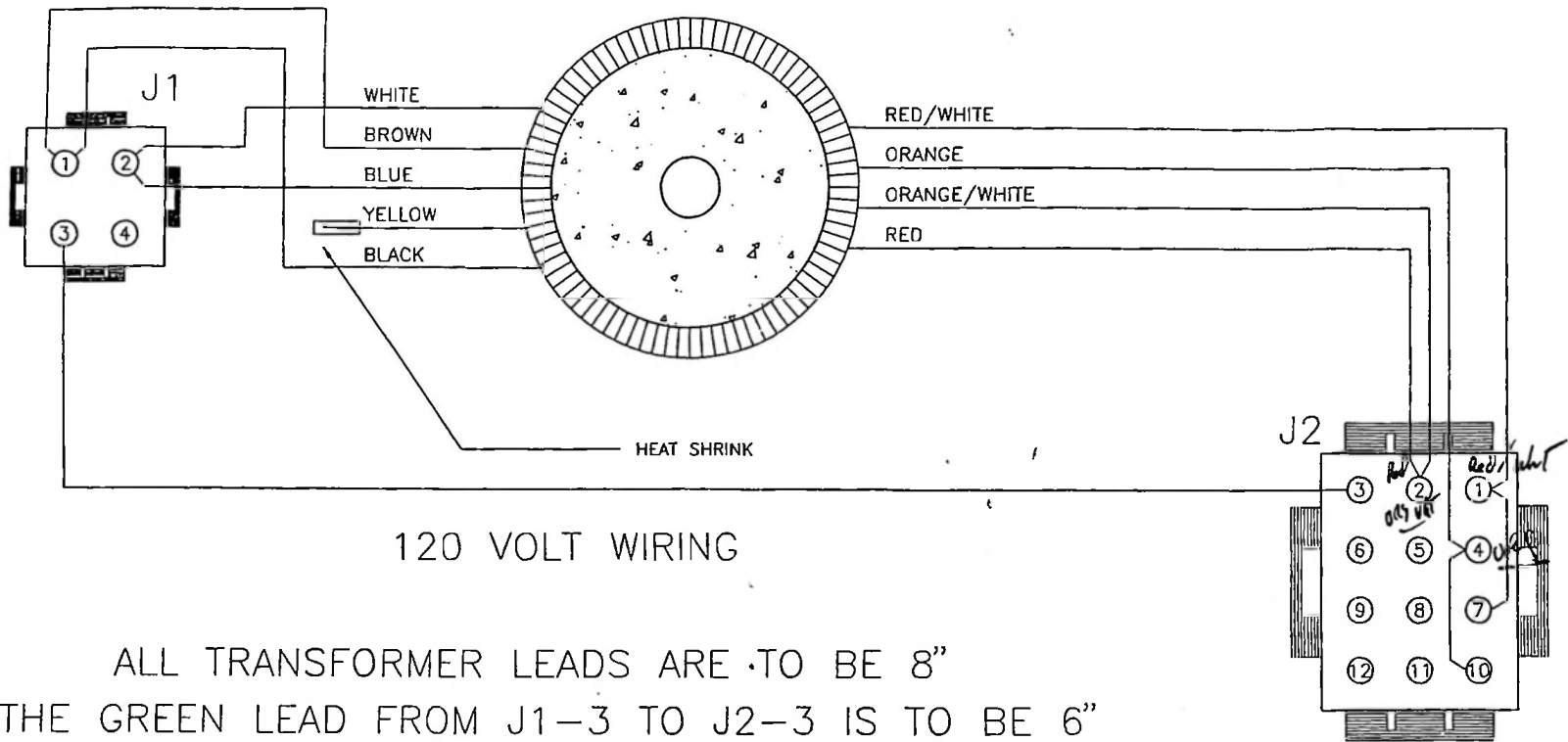

MODEL NOS.	SCHEMATIC		DWG. NO.	APPR.	REVISION LEVELS		FIDELIPAC CORP. MOORESTOWN, N.J.	THIS DOCUMENT CO OF FIDELIPAC CORP REPRODUCTION OF WITHOUT PRIOR WR
	DC10 TORIOD TRANSFORMER ASSEMBLY		827-D0-023		BILL OF MAT. XX	P.C.BOARD XX		
	SHEET	1	OF	1	ISSUE DATE 11/22/82	SCHEMATIC XX		

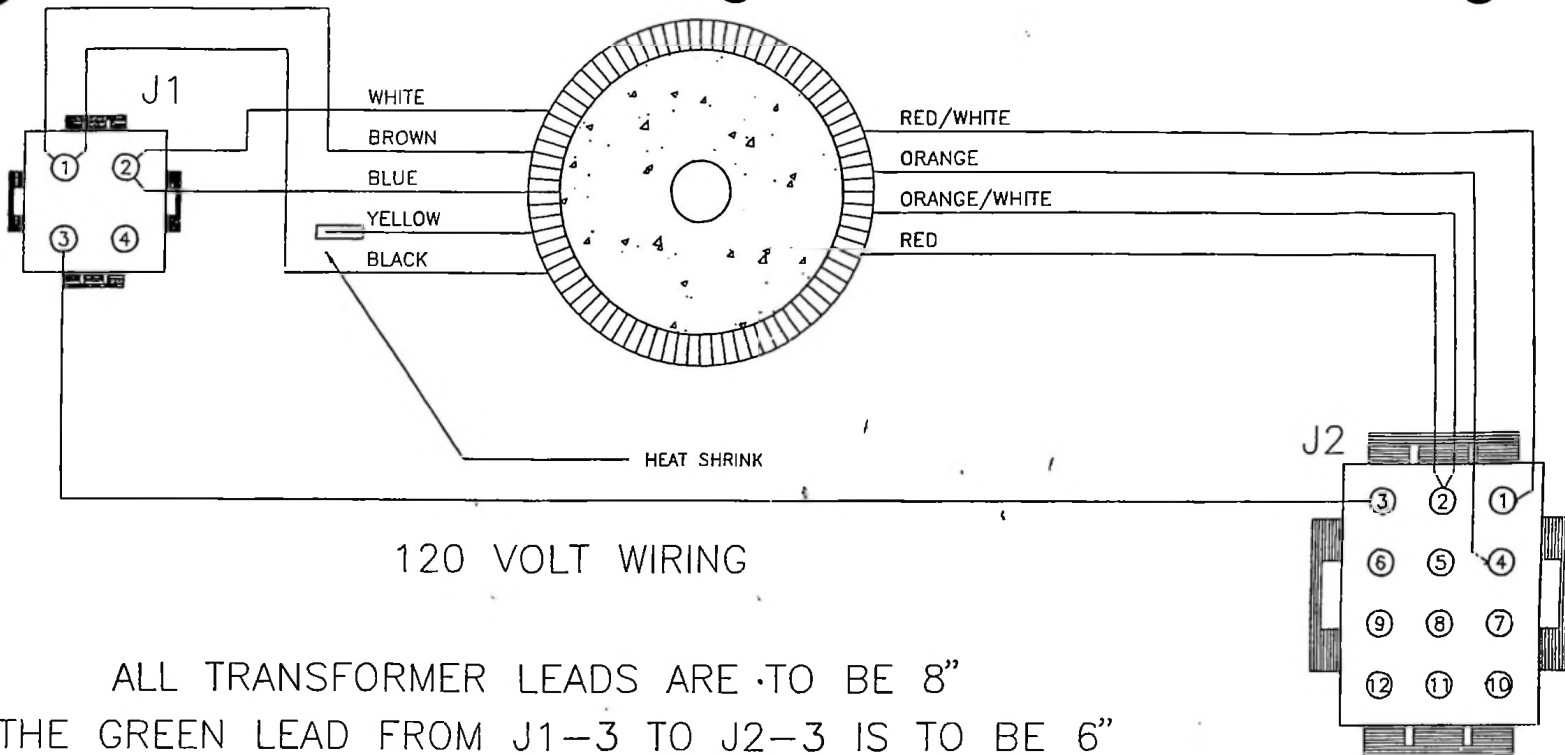

ALL TRANSFORMER LEADS ARE TO BE 8"  
 THE GREEN LEAD FROM J1-3 TO J2-3 IS TO BE 6"

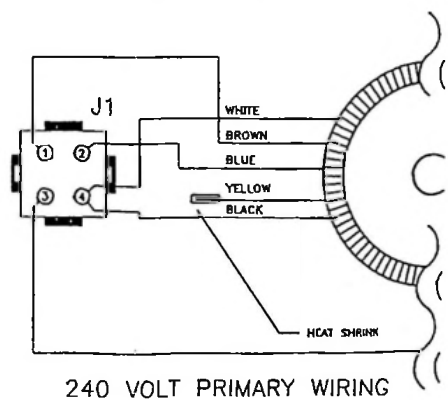
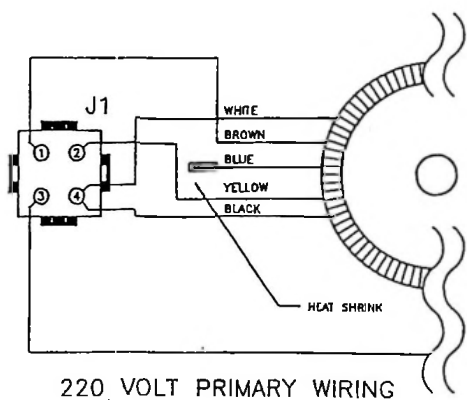
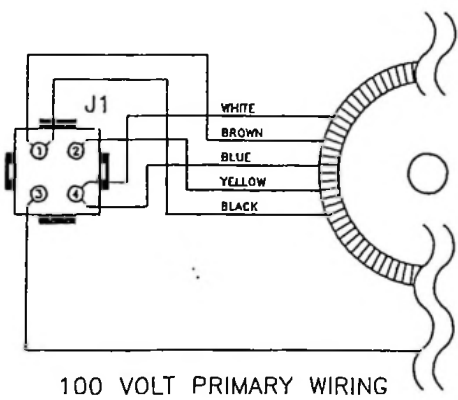

MODEL NOS.	SCHEMATIC		DWC. NO. 827-D0-023	APPR.	REVISION LEVELS			THIS DOCUMENT CO OF FIDELIPAC CORP REPRODUCTION OF WITHOUT PRIOR WR 
	DC10 TORIOD TRANSFORMER ASSEMBLY				SHEET 1 OF 1	ISSUE DATE 11/22/92		

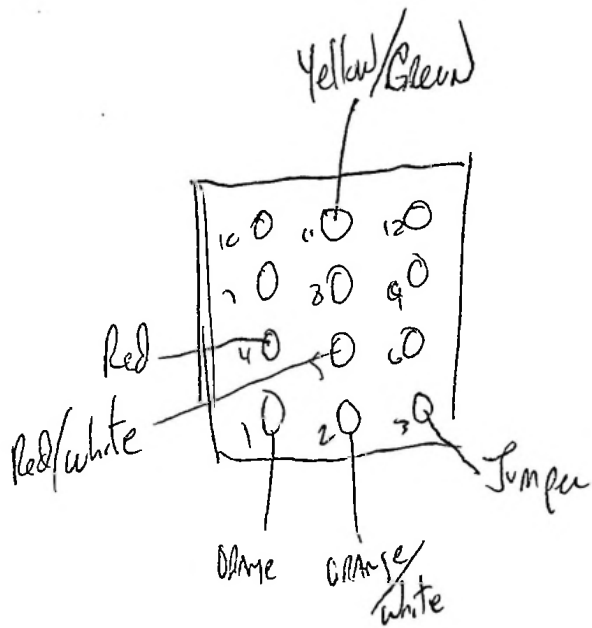

3	2	1
6	5	4
9	8	7
12	11	10

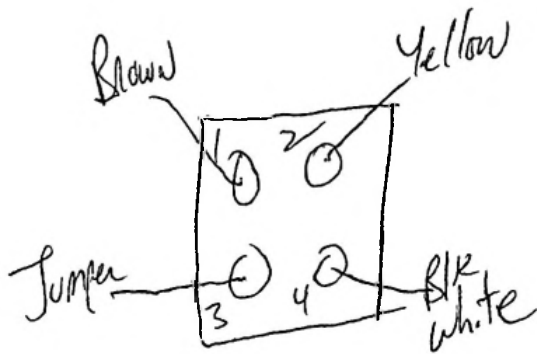

Blk is tied off

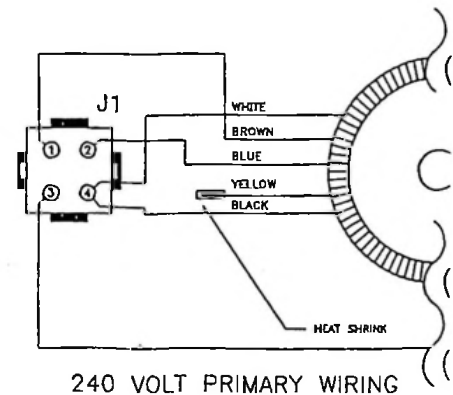
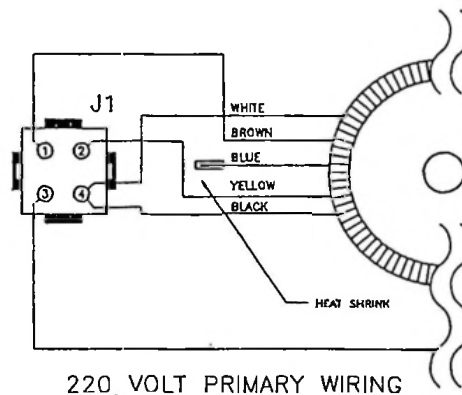
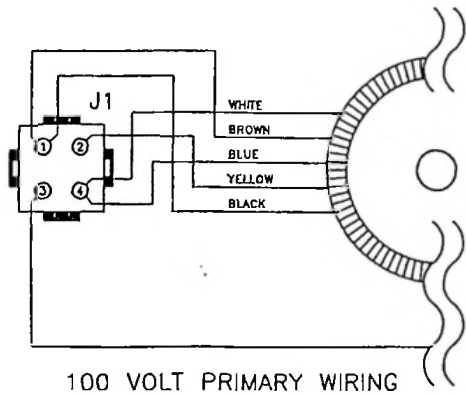
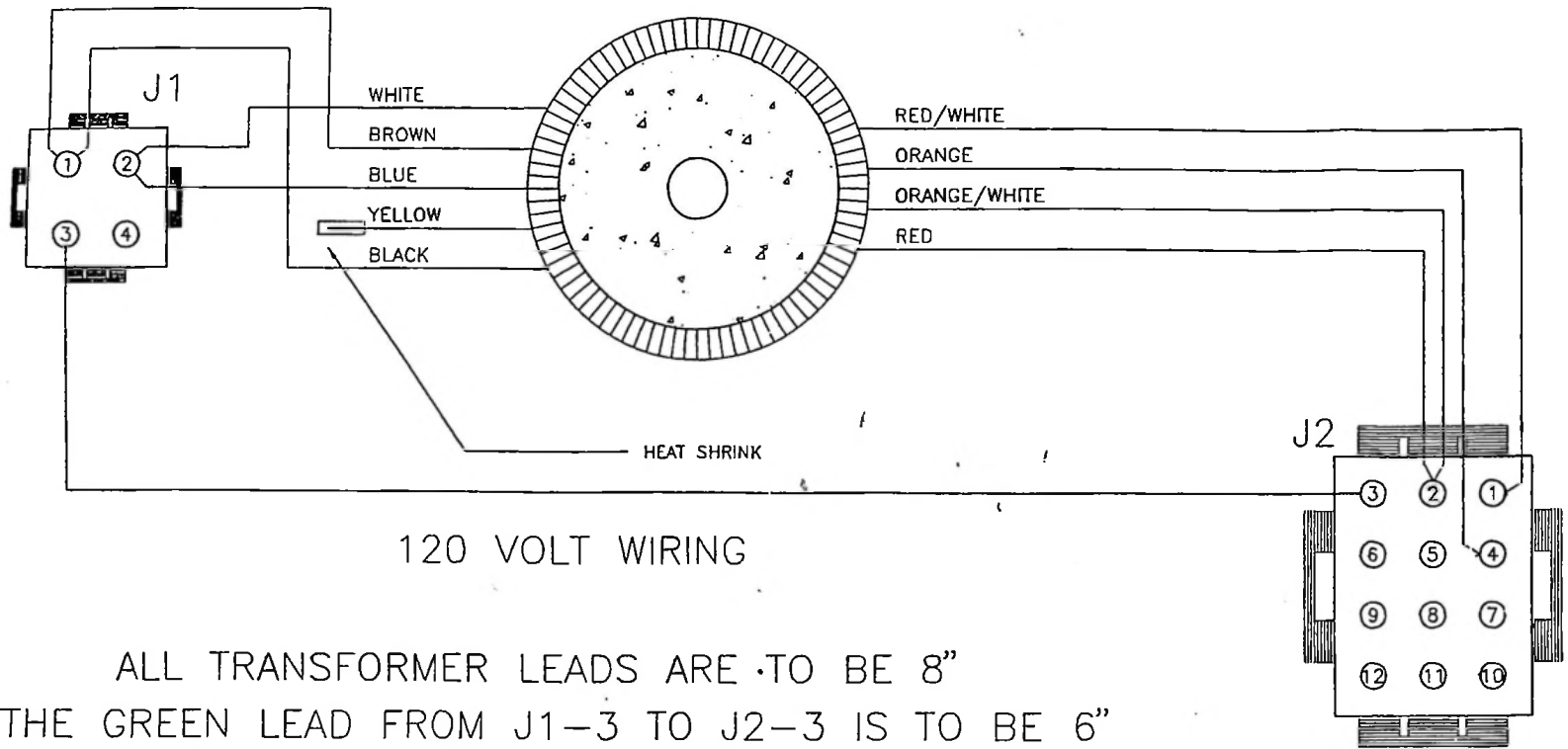

MODEL NOS.	SCHEMATIC		DWG. NO. 827-DO-023	APPR.	REVISION LEVELS		FIDELIPAC CORP. MOORESTOWN, N J	THIS DOCUMENT CO OF FIDELIPAC CORP REPRODUCTION OF WITHOUT PRIOR WRI
	DC10 TORIOD TRANSFORMER ASSEMBLY				SHEET 1 OF 1	ISSUE DATE 11/22/92		

J4-K (FF) (CART READY) R12, P5-3

-V UNREG GND

'+5V'

POWER CONNECTIONS NOT SHOWN SCHEMATICALLY

CONNECTION LOCATION	-V UNREG	MOTOR DRIVE '+5V'	-15V	GND	+15V	AUX +15V
	PIN NUMBER					
U1				8		16
U2			4		8	
U3	8	16				
U4	8	16				
U5	8	16				
U6	7	14				
U7	8	16				
U8	8	16				

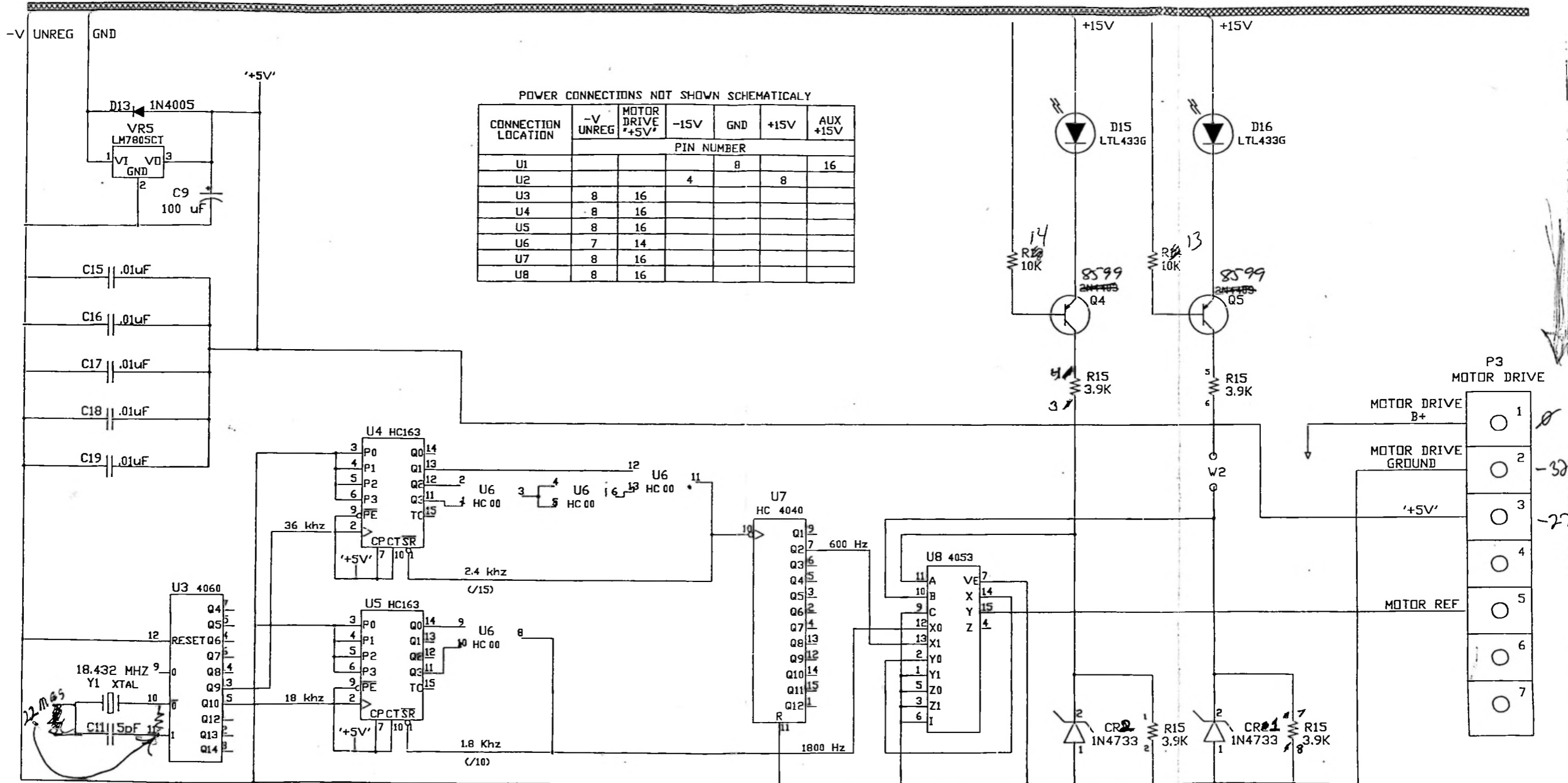



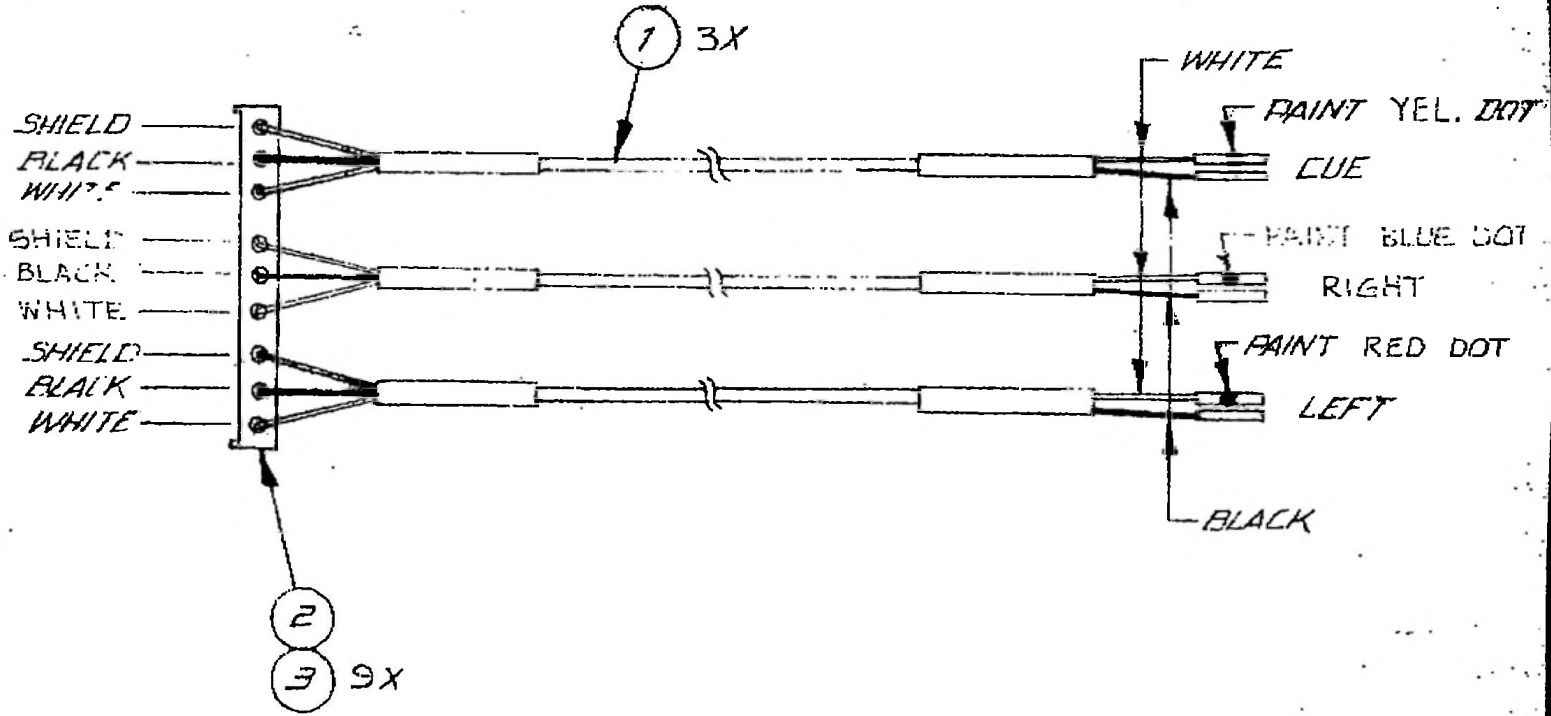

TOLERANCES (EXCEPT AS NOTED)	REVISIONS			FIDELIPAC CORP MIDDLETOWN, NJ	
	NO.	DATE	BY	SCALE	MATERIAL
DECIMAL	1				
FRACTIONAL	2				
ANGULAR	3				
	4				
	5				

  

REC. HD. CABLE ASM STEREO		DRAWN BY <i>AS Perich</i>		SCALE	MATERIAL
DATE	3/19/87	CHK'D		DATE	DRAWING NO
APP'D					837-CO-004

CTR 100, CTR 10

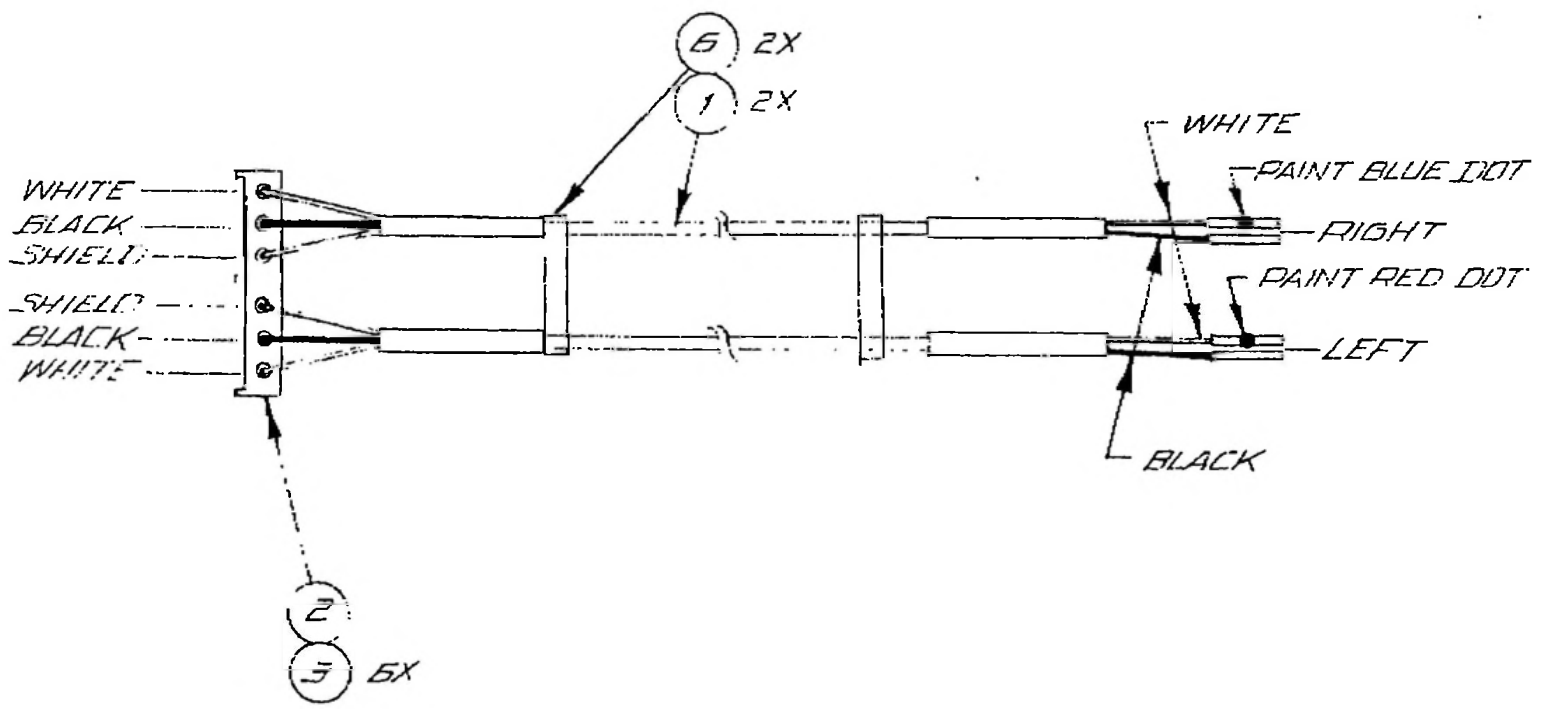

TOLERANCES (EXCEPT AS NOTED)	REVISIONS			FIDELIPAC CORP MOORESTOWN, NJ		
	NO	DATE	BY			
DECIMAL	1			PLAY HD. CABLE ASM STEREO		
±	2					
FRACTIONAL	3			DRAWN BY <i>J</i>	SCALE <i>~</i>	MATERIAL <i>~</i>
±	4			CHK'D	DATE <i>3 AUG 84</i>	DRAWING NO.
ANGULAR	5			TRACED	APP'D	<i>837-BD-001</i>

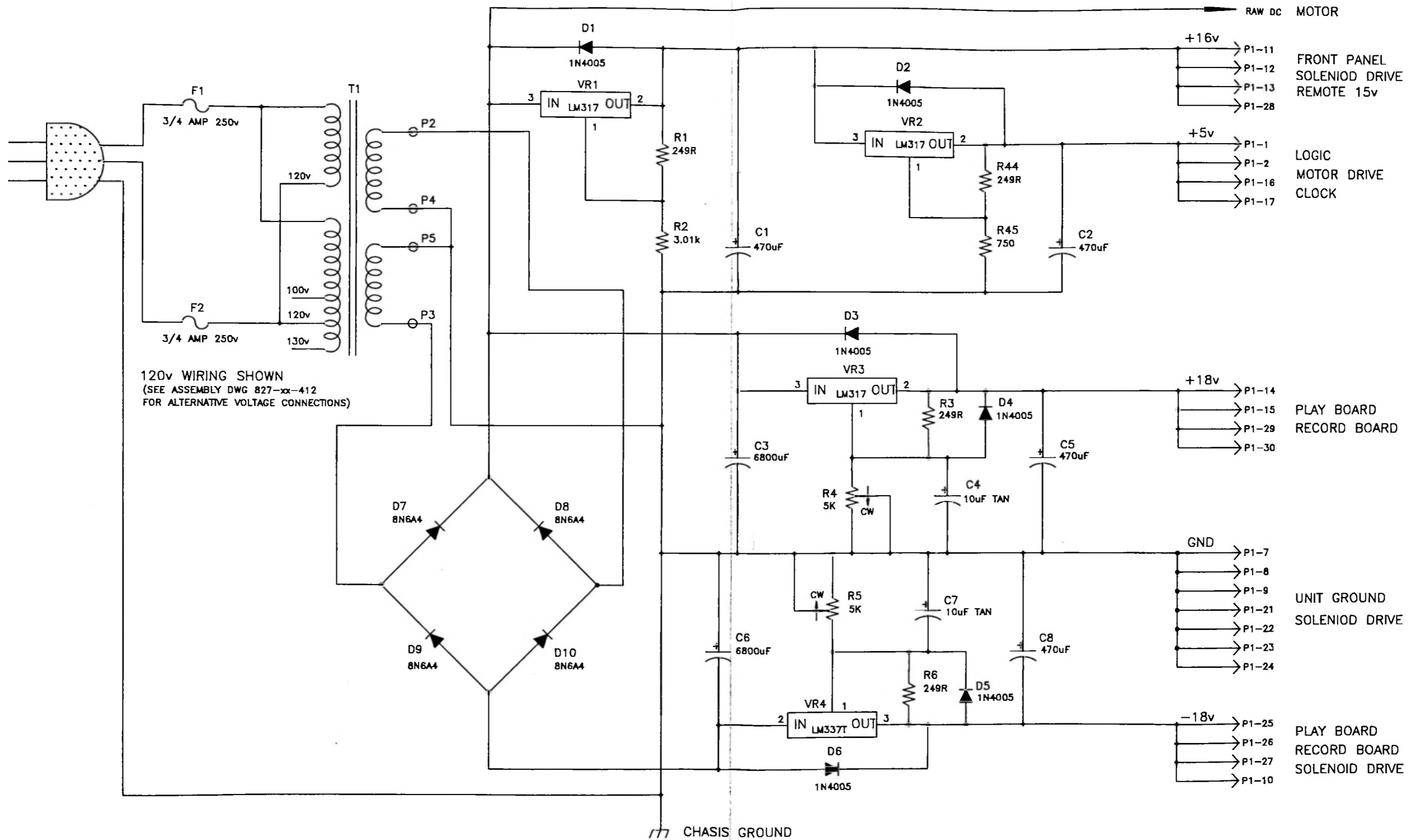

RAW DC MOTOR

FRONT PANEL  
SOLENIOD DRIVE  
REMOTE 15v

LOGIC  
MOTOR DRIVE  
CLOCK

PLAY BOARD  
RECORD BOARD

UNIT GROUND  
SOLENIOD DRIVE

PLAY BOARD  
RECORD BOARD  
SOLENIOD DRIVE

CHASIS GROUND

MODEL NOS. ALL CTR90 MODELS		SCHEMATIC POWER SUPPLY/MOTOR DRIVER MODULE		DWG. NO. 750-A0-412	APPR. <i>T.J.W./11/21/90</i> <i>M.H. 11/21/90</i>	REVISION LEVELS PWA ASSEMBLY 827-A0-412 P.C. BOARD 407-A0-412		FIDELIPAC CORP. MOORESTOWN, N.J.	THIS DOCUMENT CONTAINS PROPRIETARY INFORMATION OF FIDELIPAC CORPORATION. NO USE, DISCLOSURE OR REPRODUCTION OF ANY PART THEREOF MAY BE MADE WITHOUT PRIOR WRITTEN PERMISSION.
				SHEET 1 OF 2	ISSUE DATE 11/21/90				

SCHMPSMD

REVISIONS			
REV	DESCRIPTION	DATE	APPROVED

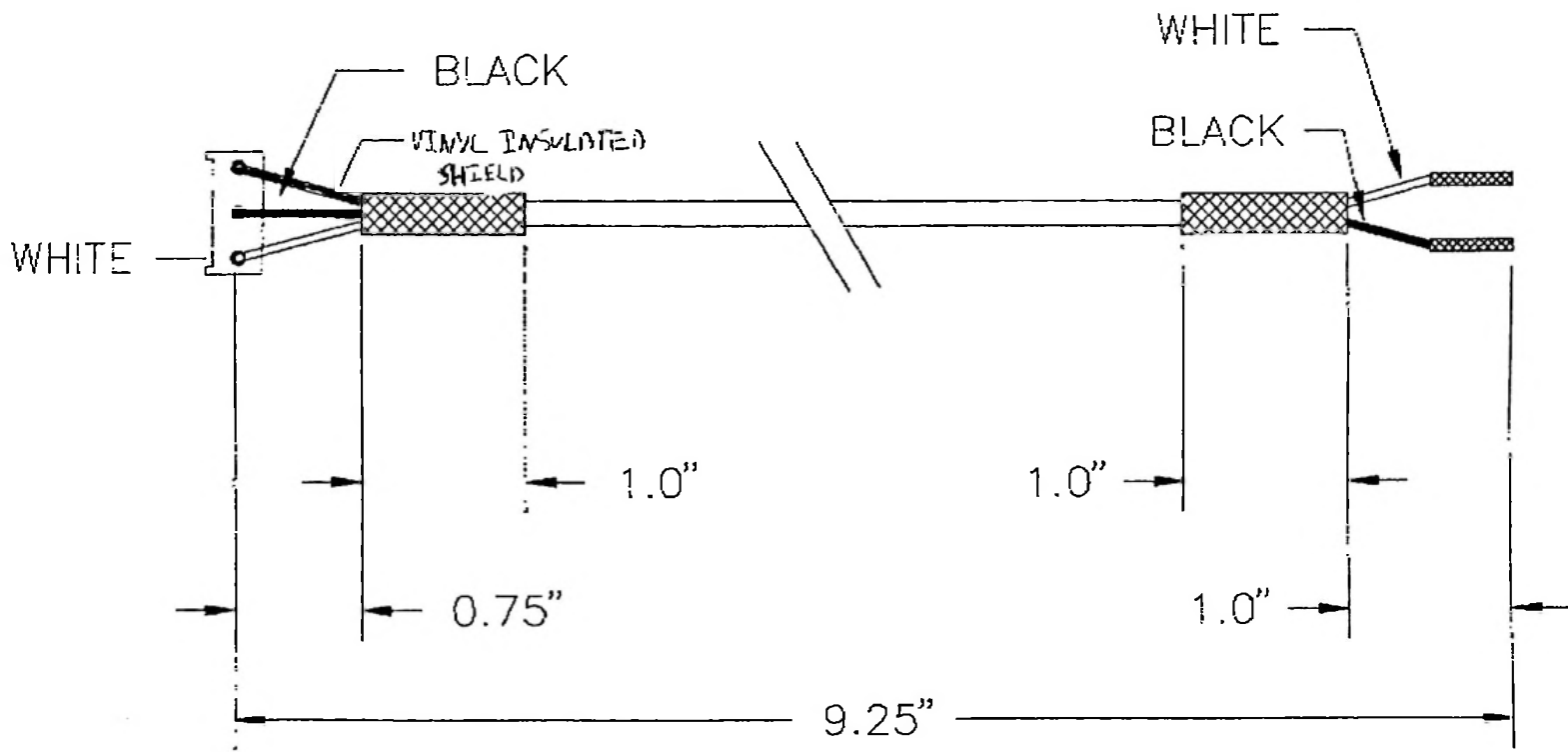

NOTE: ALL HATCHED AREAS ARE INSULATED WITH HEAT SHRINK TUBING

REMOVE ALL BURRS BREAK SHARP EDGES .015 ± .010	UNLESS OTHERWISE SPECIFIED DIMENSIONS ARE IN INCHES AND INCLUDE THICKNESS OF PLATING			CONTRACT NO.		FIDELIPAC CORP. MOORESTOWN, N.J.
	TOLERANCES ON:			DRAWN BY MH	DATE 1/92	
UNLESS OTHERWISE SPECIFIED THE SURFACE FINISH OF MACHINED PART SHALL NOT EXCEED 125 MAX.	BASIC DIM'S	2 PLACE DECIMAL	3 PLACE DECIMAL	CHECKED BY	APPROVED BY	SIZE CODE IDENT NO. A
	UP TO 6	±.02	±.005	APPROVED BY	DWG. NO. 837-B0-002	REV
	ABOVE 6 TO 24	±.03	±.010	APPROVED BY	SCALE	SHEET 1 OF 1
ABOVE 24	±.06	±.015	APPROVED BY	SCALE	SHEET 1 OF 1	REV

## Record Cards

On EACH of the three units, I was required to turn the HF Record EQ down all the way, just to keep the "hump" in the 2 dB range.

Perhaps the circuit of C10/R120 and R15 (with C9/R35/R14) ought to be adjusted for more roll? Have you tried a .1 uF instead of the .056?

- - -

Not recently. Feel free to tweek as you wish. Whatever works best is more than acceptable.

## Motor Problems:

The fourth machine is not running yet, as it runs slow Jimmy tried changing motors. I checked and found 32VDC coming into the P3 "motor drive" plug. So .... I'm guessing the problem is with the servo board. Unfortunately, my success in swapping out servo boards was not good. Two other cards made the motor run slow. One made it run FAST! and Three did not work at all.

Check the Ref Freq coming from the mother board.

600 is the freq for play,  
1800 is the FF ref.

If the LED,s are in wrong, (not working per normal) for some reason this effects the selection of the ref. freq. down on the motherboard.( the LED's are in the path of the logic used to select freq.)

Also, try a motor from a working machine, just to ensure it isn't the motor tach.

- - - -

## Servo board:

Look in a CTR100 Manual. There should be info and text concerning the servo board in there. It was originally a CTR100 item.

---

Nidec motors can be re-bearinged,  
not the Manger/Beau motors (Gold and Blue)

Once again, the only motors we even tried to re-bearing were  
Nidec AC (black flywheel)  
Nidec DC (Silver can).

Don't even try to fix:

The Beau (blue motor with gold flywheel)  
the Clifton (current production) or  
Pabst (gold German unit)

We traditionally charged \$100 flat for a motor re-bearing job.

Due to the method of pressing on a bearing, if you apply too much uneven pressure or tap the bearing incorrectly you will create a burr or dent on the inner runs of the

bearing. This will give you noise and grind. We go through a few bearings with each job. Therefore selling two bearings may not be enough if the customer doesn't have the proper tools. Which they don't.

Transformer:

● Check out the service CTR, it should have an AC motor and older motherboard.

Possibly we used the CTR 90 Transformers in the CTR10 AC units before we changed to DC Motors and the current motherboard.

Needless to say we never used the CTR90 transformer in the current CTR10/ We had the transformer from England by that time and it was too inexpensive to pass up. If you can get the numbers off the Maryland transformer and call them, you may also find the pricing and quantities required to be a little more than you wish.

---

The current England transformer has two secondary windings.

We use the larger of the two and tap this across both bridges on the mother board. This is the reason for the buss wire on the motherboard. Eventually you will be able to look into a new transformer with a single output winding and keep the mother board short as the fix. This will be an easier transformer to find. I think.

● Keep an eye on the amount of current the regulators are dumping, if the secondary windings of the transformer are too large the bridges and regulators will cook.

---

This issue hurts my brain.

So many years, so many mods, so many options, way too many products. Over the years we probably have had 10 different transformers for various machines. One would work in other machines but would always require a mod of some sort. If you find two similar transformers in two different machines, I have no doubt there is a difference in the wire harness configuration or the mother board was modified. Just like the current production motherboard is modified to accept the England transformer.

Once you understand the motherboard Power supply current needs you can experiment with optional transformers. Until then, stick to what works.

●



## Play Cards

Output pots usually face 8 to 9  
EQ pots are at 7 or 8

Remember to set the tape guides first with the HG-1 Head Gauge. Then peak you heads.

### Refurbishing boards:

For a Mono machine you need only change the Left side caps.

### Refurbish player:

1. PRK-2 Pressure Roller Kit. \$22
2. Rubber solenoid stopper. \$3
3. Replace all caps on Play card \$50 for a re-cap
4. Align and check out machine. 1 Hour @ \$65

Freight and Packing material if not returned in a reusable box. Usually \$12.50 for new packing material.

## Refurbishing of the CTR10 machines

1. If machine is more than five years old, change out all the electrolytics on the play card
2. Most of the problems relate to capacitor problems:
  - a. Frequency Response
  - b. Distortion
  - c. Cue tone
  - d. Bias Meter (right meter ... might miss on mono machines)
3. In the mono play machines, there is no need to replace the following caps on the PLAY PCB:  
C~~3~~, 6, 7, 10, 24, 36, 39, 40, 10, 53  
51
4. In the mono record machines, there is no need to replace the following caps on the RECORD PCB.  
C

## FINAL SHIPPING CHECK SHEET

- 1. Check that all screws are tight.
- 2. Install top and bottom of case, feet, etc.
- 3. Check head shield.
- 4. Clean Pinch Roller and Capstan.
- 5. Turn service switch off.
- 6. Clean any additional areas needed.
- 7. Front Panel inserts.
- 8. Packing Kit
  - a. Play cable connector
  - b. Record cable connector (if recorder)
  - c. Power Cable
  - d. Manual

Machine Serial Number: \_\_\_\_\_

Check out by \_\_\_\_\_

Date: \_\_\_\_\_

REC.TONE METER

PLAY CUE LOGIC

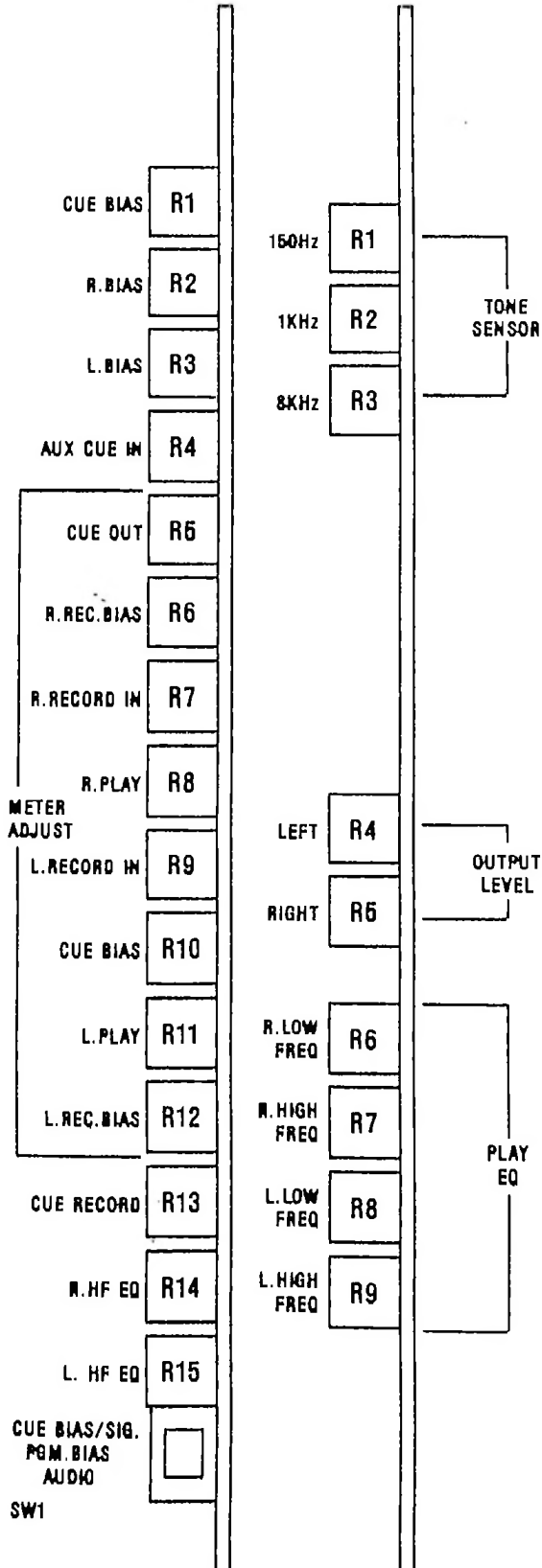

REC.TONE METER

PLAY CUE LOGIC

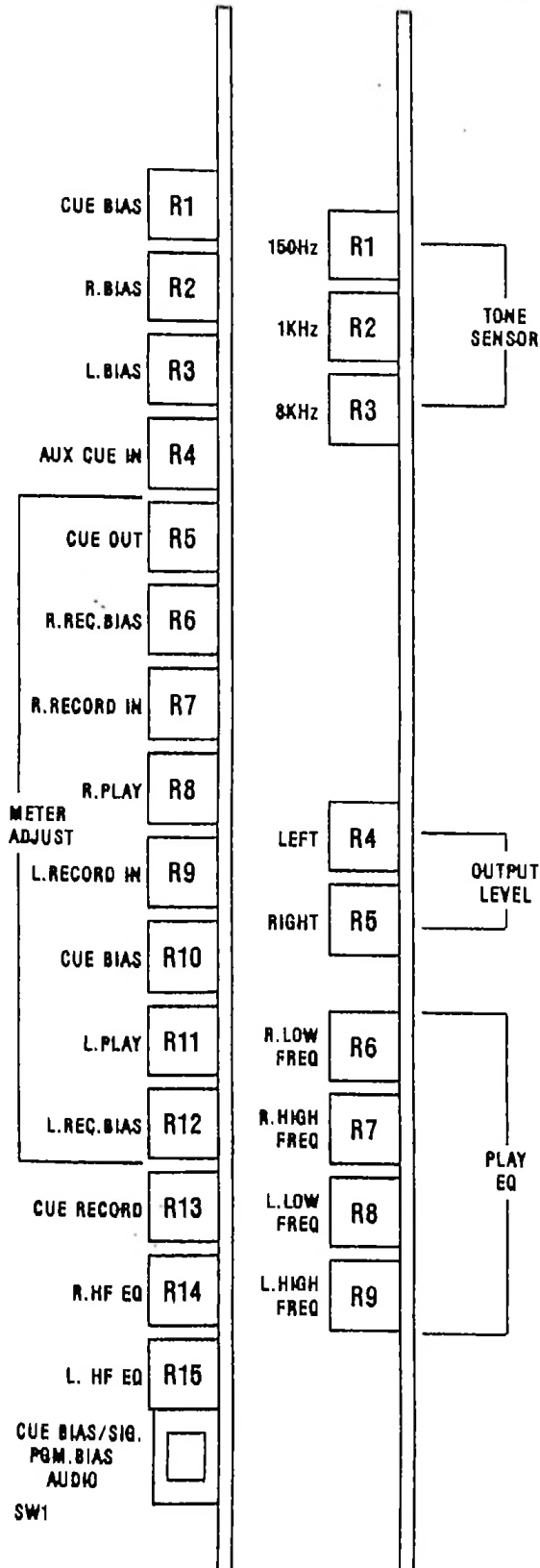

REC.TONE METER

PLAY CUE LOGIC

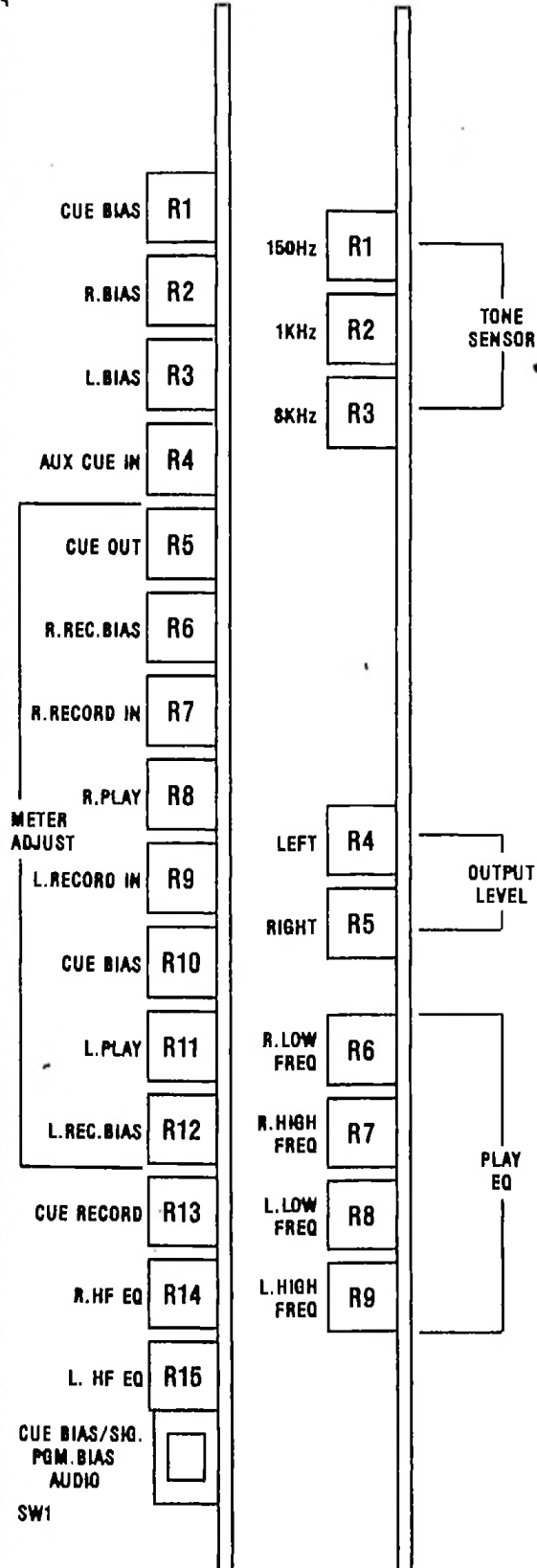

ALL ADJUSTING / LOCKING SCREWS  
 SOCKET HEAD 5/64

AZIMUTH ADJUSTMENT  
 SCREWS  
 ZENITH ADJUSTMENT SCREWS

INSERTION  
 ADJUSTMENT  
 SCREWS  
 USE FIDELIPAC HEAD  
 INSERTION GAGE NO. J28

HEAD BRIDGE  
 MTR. SCREW (SOC. NO. 7/64)  
 HEIGHT ADJUSTMENT SCREWS

HEIGHT ADJUSTMENT  
 TAPE GUIDE ADJUSTMENT  
 SCREWS

HEAD CLAMPING SCREWS  
 HEADS ARE INSTALLED SEATED AGAINST  
 CLAMPING SCREWS

TAPE GUIDE ADJUSTMENT  
 ALIGN TOP EDGE OF GUIDE WITH  
 TOP OF GAGE

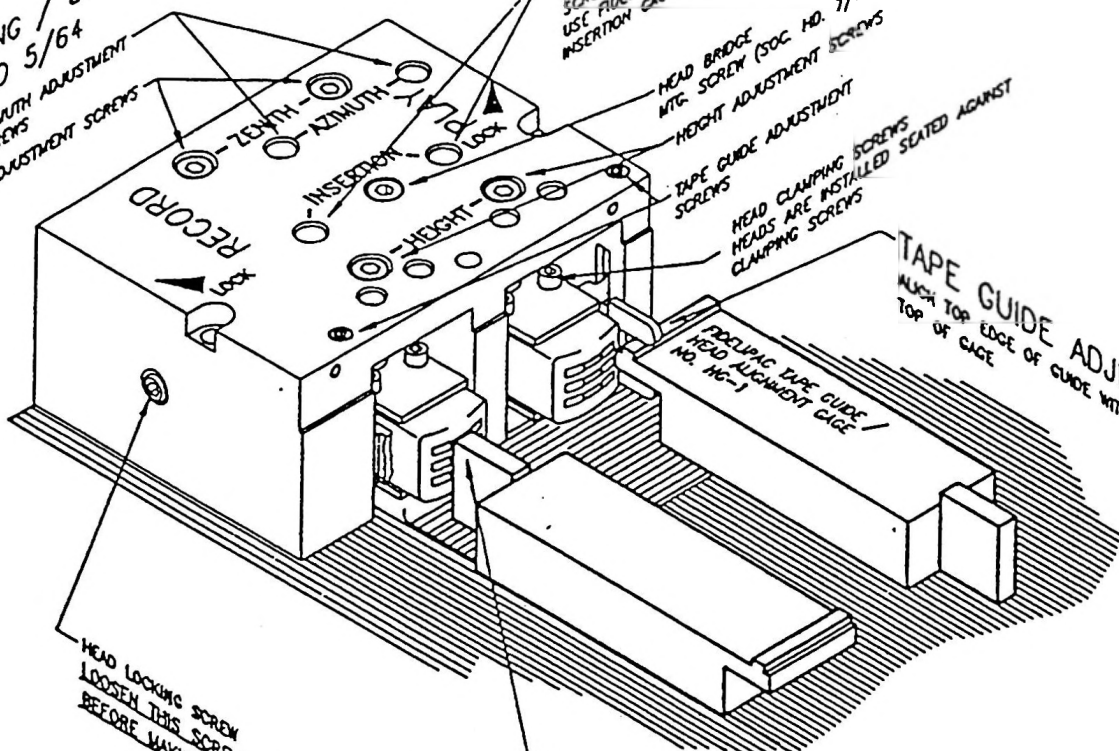

HEAD HEIGHT ADJUSTMENT  
 ALIGN TOP OF TRACK WITH  
 TOP OF GAGE

HEAD ZENITH ADJUSTMENT  
 SQUARE FACE OF HEAD WITH  
 FACE OF GAGE

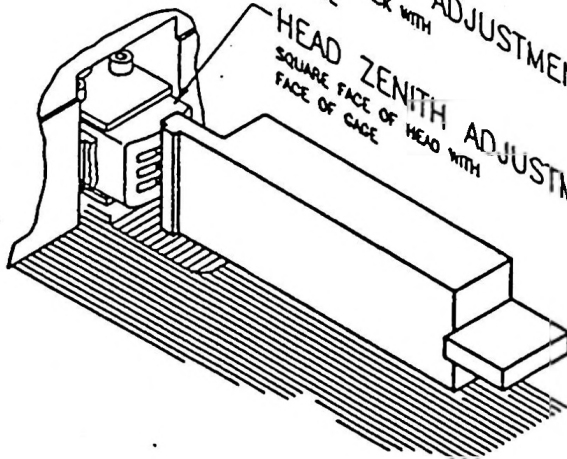

MECHANICAL ALIGNMENT LOCATIONS

DWG. NO.	750-80-440	APPR. T.J.W.
SHEET	2 OF 2	ISSUE DATE 2/6/91

ALL ADJUSTING / LOCKING SCREWS  
 SOCKET HEAD 5/64

ZENITH ADJUSTMENT SCREWS  
 AZIMUTH ADJUSTMENT SCREWS

INSERTION ADJUSTMENT SCREWS  
 USE FIDUCIARY HEAD INSERTION GAGE NO. J28

HEAD BRIDGE MTC. SCREW (SOC. NO. 7/64)  
 HEIGHT ADJUSTMENT SCREWS

TAPE GUIDE ADJUSTMENT SCREWS

HEAD CLAMPING SCREWS  
 HEADS ARE INSTALLED SEATED AGAINST CLAMPING SCREWS

TAPE GUIDE ADJUSTMENT  
 ALIGN TOP EDGE OF GUIDE WITH TOP OF GAGE

HEAD LOCKING SCREW  
 LOOSEN THIS SCREW (BOTH SIDES)  
 BEFORE MAKING ANY ADJUSTMENTS

HEAD HEIGHT ADJUSTMENT  
 ALIGN TOP OF TRACK WITH TOP OF GAGE

HEAD ZENITH ADJUSTMENT  
 SQUARE FACE OF HEAD WITH FACE OF GAGE

OWC. NO.	750-80-440	APPR. T.J.W.
SHEET 2 OF 2	ISSUE DATE 2/6/91	

MECHANICAL ALIGNMENT LOCATIONS



ALL ADJUSTING / LOCKING SCREWS  
 SOCKET HEAD 5/64

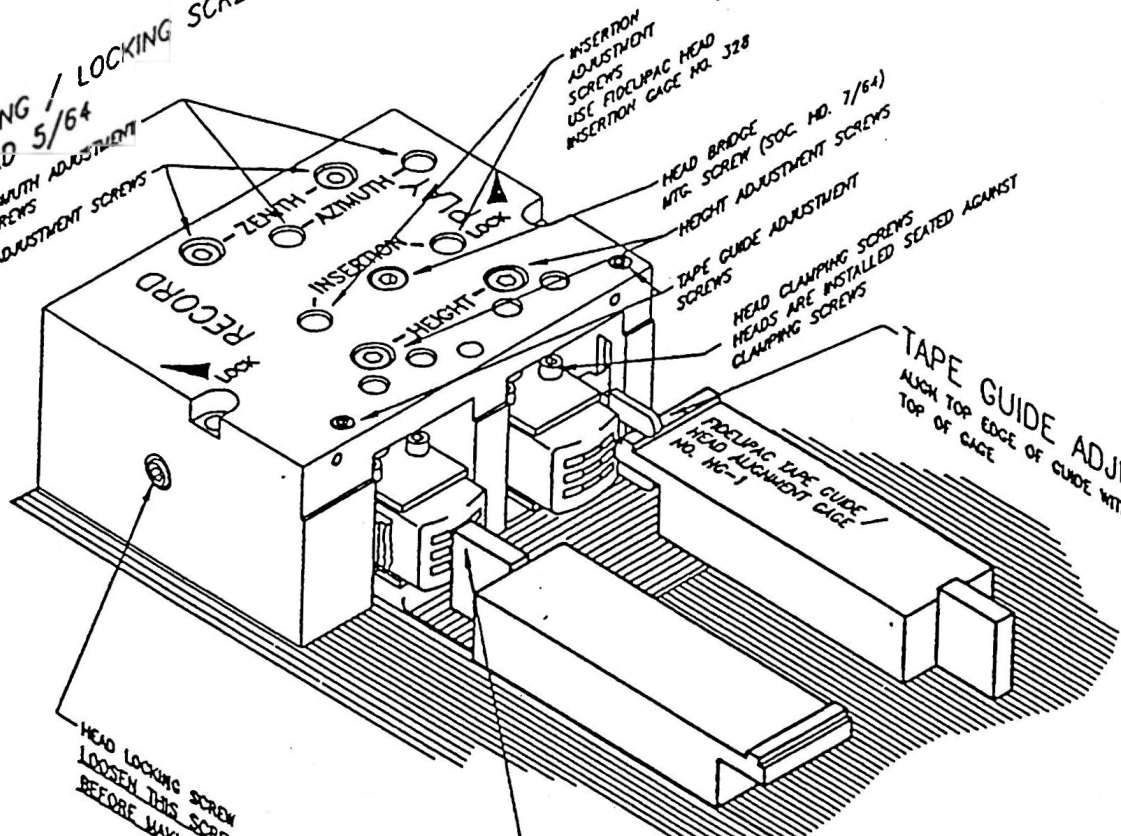

TAPE GUIDE ADJUSTMENT  
 ALIGN TOP EDGE OF GUIDE WITH  
 TOP OF GAGE

HEAD LOCKING SCREW  
 LOOSEN THIS SCREW (BOTH SIDES)  
 BEFORE MAKING ANY ADJUSTMENTS

HEAD HEIGHT ADJUSTMENT  
 ALIGN TOP OF TRACK WITH  
 TOP OF GAGE

HEAD ZENITH ADJUSTMENT  
 SQUARE FACE OF HEAD WITH  
 FACE OF GAGE

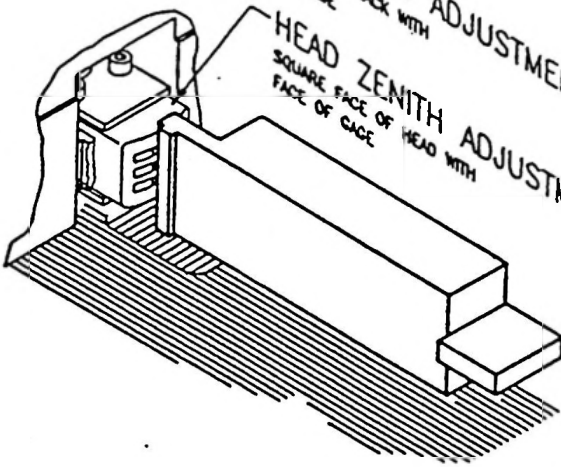

MECHANICAL ALIGNMENT LOCATIONS

DWG. NO.	750-B0-440	APPR.	T.J.W.
SHEET	2 OF 2	ISSUE DATE	2/6/91

ALL ADJUSTING / LOCKING SCREWS  
 SOCKET HEAD 5/64  
 AZIMUTH ADJUSTMENT  
 ZENITH ADJUSTMENT SCREWS

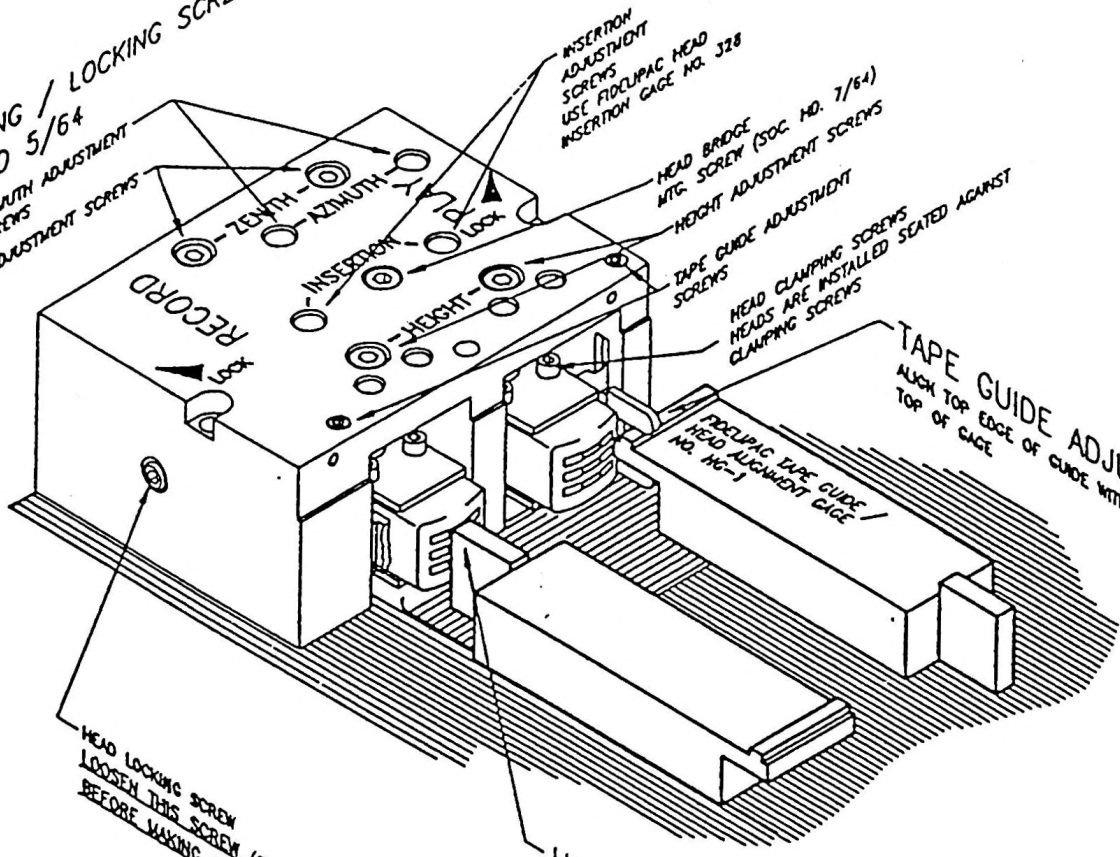

HEAD LOCKING SCREW  
 LOOSEN THIS SCREW (BOTH SIDES)  
 BEFORE MAKING ANY ADJUSTMENTS

HEAD HEIGHT ADJUSTMENT  
 ALIGN TOP OF TRACK WITH  
 TOP OF GAGE

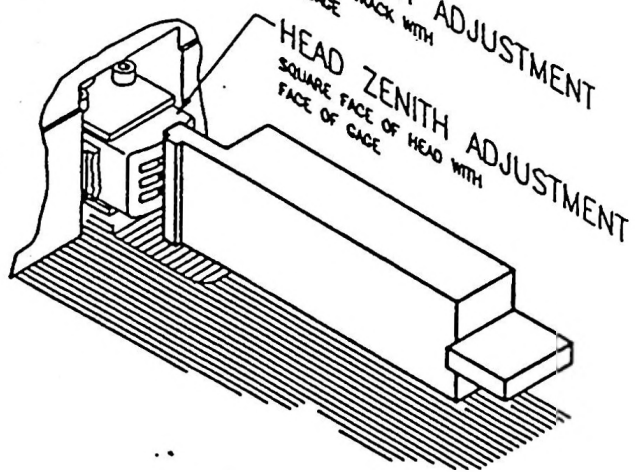

MECHANICAL ALIGNMENT LOCATIONS

DWG. NO.	750-80-440	APPR. <i>T.J.W.</i>
SHEET	2 OF 2	ISSUE DATE 2/6/91

176-11-104	20	179	CTR	Missing	Missing	
					SETERLING # 2300	
200-AD-000	220	100	MX	1N4148	FUTURE # 1107	
210-AD-002	120	50	MX	MOTOROLA MPS 2222	MARLAC 1780	
210-AD-003	20		CTR	Missing	FUTURE # 1107	
					SETERLING # 2300	
220-AD-000	40		MX	1N4148	FUTURE # 1107	
230-AD-001	20	14	CTR		MARLAC 1780	
					GCI # 1110	
230-AD-009	20	10	CTR	Missing	GRS # 1155	
230-AD-014	20	10	CTR	Missing	Missing	
231-AD-027	20		CTR	Missing	Missing	
231-AD-032	60	185	CTR	Missing	Missing	
407-CO-110	20	34	CTR	Missing	MAYBE IN WARE HOUSE	
410-AD-001	60		MX	SEE ABOVE		
410-AD-002	160		MX	SEE ABOVE	FAI # 65 LTO 314 T	
					ADVENT	
410-AD-003415-AD-006	60		MX	PRECISION LTO 316 T	ADVENT	
					ACTIVE #70	FAI
					#65	
416-AD-006	40	10	MX	AMP # 646502-1	MORLAC #1780	AIM
					FEDERATED PRCHASE	1008
416-AD-015	20		OBX	MOLEX 10-32-1063	STERLING # 2300	
420-AD-002	0				GRS # 1155	
541-AD-040	20	14	CTR	BELDEN 8013	KASS ELEC. # 1545	16 GA BUSS WIRE
				Missing	ABLE ELECTRONIC	
Parts needed for Board #827-AD-018						
110-22-130	90				TONAR 3070	
					TONAR 3070	
110-32-681	90				GCI CORP # 1110	
					DIGI KEY CORP # 800	
260-AD-001	90	50	MX	NORMAL LAMPS # 382	BROTHERS # 440	
					MARLAC # 1780	
364-AD-005	90	10	MX	ITW LICON 05-65125	RELAY SPEC. # 2605	
364-AD-006	30	30	MX	ITW LICON 80-050602	ADUACOM # 92	
					SAGER # 2683	I HAVE ANOTHER ONE EMAIL ME
364-AD-007	30	30	MX	ITW LICON 80-050603	POWELL ELC. # 2410	
250-AD-004	30	18	CTR	Missing	ALAR # 115	
					PRO COMPONENT # 2540	
410-AD-003	30		MX	PRECISION LTO 316 T	ADVENT	
					ACTIVE #70	FAI
					#65	
Parts for # 827-AD-020						
110-22-130	180				TONAR 3070	
					BROTHERS # 440	
260-AD-001	180		MX	NORMAL LAMPS # 382	MARLAC # 1780	
364-AD-005	180		MX	ITW LICON 05-65125	RELAY SPEC. # 2605	
364-AD-006	90		MX	ITW LICON 80-050602	ADUACOM # 92	
					SAGER # 2683	
364-AD-007	60		MX	ITW LICON 80-050603	POWELL ELC. # 2410	
407-AD-090	30	23	CTR	Missing	ALAR # 115	
					PRO COMPONENT # 2540	
410-AD-003	30		MX	PRECISION LTO - 316J	ADVENT	
Parts for # 827-BO-024					ACTIVE # 70	
414-AD-007	30	190	CTR	827-AD-068	FAI # 65	
				Missing	Missing	
423-A2-20N	600			600 11022B	ALAR # 115	WIRE STRANDED 22 AWG BLACK
423-A2-25N	480			450 11022B	ABLE # 43	WIRE STRANDED 22 AWG GREEN
423-A2-29N	360			560 11022-WHITE	ABLE # 43	WIRE STRANDED " " WHITE
44S-AD-000	60			90 FIT - 221 3/16 BLK	MARLAC # 1780	SHRINK TUBING
44S-AD-001	30			60 FIT - 221 1/8 BLACK	GCI # 1110	SHRINK TUBING
44S-AD-002	30			60 FIT - 221 3/4 BLACK	MARLAC # 1780	SHRINK TUBING
					GCI # 1110	SHRINK TUBING
					MARLAC # 1780	SHRINK TUBING

110-22-391	25			TONAR 3070 GCI CORP # 1110 TONAR 3070 USH # 3243 CORP # 1110 TONAR 3070 TONAR 3070 TONAR 3070 GCI CORP # 1110 TONAR 3070 TONAR 3070 TONAR 3070 BROTHERS ELEC. #440 ADVENT #93 TONAR 3070 BROTHERS ELEC. #440 ADVENT #93 AIM # 103 TONAR 3070 GCI CORP # 1110 NEWARK #2120 AIM # 103 FAI 065 TTI # 2945	GCI
110-22-392	50				
110-22-682	50				
110-22-753	50				
110-22-821	50				
110-22-473	50				
110-22-393	50				
110-22-121	50				
120-20-105	100				
120-20-51N	50				
110-32-101	50		100 OHM 1/2W 5%		
144-11-103	50	25	MX	BOURNS # 4608X- 102-103 NEWARK (81F9207R 10.7K)	
144-11-104	50	25	MX	BOURNS # 4608X- 102-104	
144-11-105	50	25	CTR	Missing	
PARTS NEEDED FOR THE ESD 10 BOARD		Items for 20 Boards			
006-A4-102	40	10	MX	P4200-ND	DIGI-KEY #800
006-A6-103	200	0	MX	P4300A-ND	DIGI-KEY #800
011-A5-105	120	25	MX	UVXH010M	STANDARD RADIO #2877
011-A5-106	100	25	MX	ILLINOIS 106RMR050M	FUTURE #2450 STANDARD RADIO # 2877
011-A5-107	20	0	CTR	UVXV101MPA	ADVENT # 93
031-A3-101	20	50	MX	DM10-101J	PEAK ELEC. # 2275
031-A3-220	20	25	MX	DM15-220J	STANDARD RADIO # 2877
041-A3-103	20	25	MXD	P4513-ND	ADVENT # 93 DIGI-KEY #800
041-A3-332	40	25	MX	PANASONIC ECQ B1H332JF	ADVENT # 93 DIGI-KEY #800
041-A4-104	140	140	MXD	USE 001-AK-10A	Missing
041-A4-472	20	20	MXD	BF014DC4725	ADVENT # 93
041-A4-474	20	2	CTR	Missing	Missing
100-32-100	20			308J500-10 RES Carbon 10 R 5%	Mouser # 1836 GRS # 1155 USH #3243 STANDARD RADIO 2877
110-22-102	40				BROTHERS #440 VSH #3243 ADVERT #93
110-22-103	160				
110-22-104	200				
110-22-105	80			NCF 25 IMB	AIM # 1780
110-22-10A	40			NCF 25 J 105B	
110-22-122	40			Nothing fill	Nothing fill TONAR 3070 BROTHERS ADVERT 93
110-22-152	20				
110-22-153	20				
110-22-154	20				TONAR #3070 GCI#1110 TONAR 3070 TONAR 3070 VSH 3243 TONAR 3070 TONAR 3070
110-22-184	20				
110-22-223	20				
110-22-332	60				
110-22-333	40			SCF 2533K5 %	MARLAC # 1780 TONAR 3070 GCI CORP # 1110 ADVENT # 93 TONAR 3070 USH # 3243 CORP # 1110 TONAR 3070 TONAR #3070 GCI#1110 TONAR 3070 ADVENT # 93
110-22-334	40				
110-22-392	100				
110-22-472	60				
110-24-473	20				
110-22-474	20				
110-22-621	20				
110-????	20				
120-20-68J	20			Missing	Missing
120-20-68N	20			Missing	Missing
13T-33-502	40	66	CTR	Missing	Missing

MOTHER BOARD PARTS NEEDED	QTY=50	PC	MFG P/N	VENDOR
006-A6-103	250	0	P4300A -ND	DIG-KEY #800
031-A3-221	150	25	MX DM10-221J	FAI 065
110-22-103	450		RES	STANDARD RADIO 2877
110-22-104	50		RES	BROTHERO #440
110-22-223	150		RES	VSH #3243
110-22-471	50		RES	ADVERT #93
110-22-472	50		RES	TONAR 3070
110-22-473	50		RES	TONAR 3070
110-22-474	50		RES	TONAR 3070
144-11-392	50	25	RES	GCI #1110
200-A0-000	50	25	MX	TONAR 3070
210-A0-003	100		CTR	FAI 065
230-A0-010	50		CTR	AIM # 103
231-A0-405	50	10	MX	ADVENT # 93
410-A0-001	50	100	MX	SETERLING # 2300
410-A0-002	50	50	MX	FUTURE # 1107
410-A0-003	400	50	MX	MARLAC 1780
416-A0-006	50	10	MX	Missing
416-A0-011	50	0	MXD	Missing
416-A0-016	100	0	CTR/CBS	Missing
PARTS NEEDED FOR THE RECORD BOARD				
006-A6-103/	325	0	MX	SN74HC4060N
011-A5-105	325	25	MXD	LTO-308T
011-A8-107	150	0	MXD	LTO-314T
011-B5-336	50	0	MX	PREC1 - LTO 316 T
011-A5-475	50	165	CTR	AMP # 646502-1
011-A5-106	200	50	MX	AMP # 640456-6
041-A3-103	100	100	MXD	39-31-3096
041-A4-473	75	300	CTR	P4300A -ND
041-A4-472	75	75	MXD	UVXH010M
041-A4-104	75	100	MXD	UVXM101MPA
031-A3-101	150	50	MX	ILLINOIS 336RMR035M
011-A5-226	25	0	MX	Missing
110-22-103	175			ILLINOIS 106RMR050M
110-22-104	75			P4513-ND
110-22-105	75			Missing
110-22-102	175			BF014D04725
110-22-152	75			SR215C104KAA
110-22-154	100			DM10-101J
110-22-114	25			ILLINOIS 226 RMR 025 M
110-22-184	25			NCF25100KB
110-22-204	25			NCF 25 IMB
110-22-221	100			NCF 25 J 105B
110-22-222	125			
110-22-224	25			
110-22-273	25			
110-22-331	25			
110-22-332	75			
110-22-333	50			
110-22-334	25			

Legend

CTR INDICATES YOU HAVE BUY CARDS, 4TH COLUMN LAST REPORTED INV U SHLD HAVE

MX I HAVE BUY CARD

MXD I HAVE BUY CARDS

RES THESE ARE COMMON RESISTORS YOU SHOULD BE ABLE TO BUY

4TH COLUMN I WILL PROVIDE SOME SAMPLE QTY IF I HAVE THEM

CTR12

PLAY

FIDELIPAC CORPORATION - INDENTED BILL OF MATERIAL

ASSY NUMBER 857B0007 CTR12,DC VERSION REV DATE 07/13/99 PAGE: 1

TYPE	PART NUMBER	QTY	UOM	DESCRIPTION	NEXT ASSY	CIR SYN	CODE	BOX	X/N
	541B0024	1	EA	BOTTOM COVER	857B0007		1		K
	541C0016	1	EA	TOP COVER "A"	857B0007		1		K
	583A0000	2	EA	BUTTON TOP COVER	857B0007		1		K
	5A1A0000	4	EA	RUBBER FOOT	857B0007		1		K
	5B2A0014	2	EA	SPCK SS 1/4"ODX5/16"LG X	857B0007		1		K
	60100660	2	EA	#6 FLAT WASHER STL PLATE	857B0007		1		K
	60507000	2	EA	WASHER 1/4 ID X 3/8 OD SS	857B0007		1		K
	60C11600	4	EA	L WASHER I.T. #6	857B0007		1		K
	62103632	2	EA	SCREW PH PHIL 6-32X5/16PL	857B0007		1		K
	62105632	4	EA	SCREW PH PHIL 6-32X5/16PL	857B0007		1		K
	62108632	2	EA	SCREW PH PHL 6-32X1/2 LG	857B0007		1		K
A	847B0007	1	EA	TOP ASSY, CTR12 DC VBR	857B0007		1		K
	. 340A0002	1	EA	PLAY HEAD STEREO	847B0007		1		K
	. 340A0004	1	EA	DUMMY HEAD	847B0007		1		K
	. 42CA0001	1	EA	RIBBON CABLE ASSEMBLY	847B0007		1		K
	. 525A0008	1	EA	PARTITION COVER, CTR10	847B0007		1		K
	. 525C0400	1	EA	MOTOR SHIELD	847B0007		1		K
	. 525C0401	1	EA	HEAD SHIELD,CTR10'S	847B0007		1		K
	. 541C0018	1	EA	PARTITION A	847B0007		1		K
	. 541F0022	1	EA	SIDE PANEL LEFT CTR	847B0007		5		K
	. 541F0023	1	EA	SIDE PANEL RIGHT	847B0007		1		K
	. 581A0007	1	EA	OVERLAY LOGO FRONT PANEL	847B0007		1		K
	. 581A0012	1	EA	FRONT PANEL OVERLAY	847B0007		1		K
	. 581A0013	1	EA	LABEL, PARTITION COVER	847B0007		1		K
	. 5A4A0002	1	EA	CARD GUIDE	847B0007		1		K
	. 5ABA0008	1	EA	CAP TRUNK SCREW	847B0007		1		K
	. 60700400	1	EA	#4 FLAT WASHER STL PLATE	847B0007		1		K
	. 60718632	4	EA	NUT CAPTIVE	847B0007		1		K
	. 62104440	1	EA	SCREW,PH PAN 4-40X1/4 SP	847B0007		1		K
	. 62104632	10	EA	SCREW PH PHIL 6-32X1/4 PL	847B0007		1		K
	. 6210C032	2	EA	SCREW PH PHIL 10-32X3/4SP	847B0007		1		K
	. 64503632	4	EA	SCREW FL PHIL6-32X5/16 SS	847B0007		1		K
	. 64504632	20	EA	SCREW,PH FL 6-32x1/4 SP	847B0007		1		K
	. 64504832	4	EA	SCREW FL PHIL 8-32X1/4 SS	847B0007		1		K
	. 64506032	4	EA	SCREW,PH PH,10-32x5/8 SS	847B0007		1		K
	. 6Y204632	1	EA	SCRW SOC HD CAP 6-32X1/4	847B0007		1		K
	. 6Y218632	2	EA	SCRW SOC RC 6-32X1 3/8 BK	847B0007		1		K
A	. 807C0065	1	EA	SERVO PWA	847B0007		1		K
	. . 006A6103	6	EA	PANASONIC 4500a-ND	807C0065		1		K
	. . 006B4100	2	EA	CAP, 10PF D	807C0065		1		K
	. . 011A3105	2	EA	10UF 50V B CAP	807C0065		1		K
	. . 011A3106	6	EA	100F 50V B CAP	807C0065		1		K
	. . 011A3107	1	EA	100UF 25V B CAP	807C0065		1		K
	. . 041A3102	1	EA	.001uf,50v CAP	807C0065		1		K
	. . 041A3103	2	EA	CAP.01/63/5	807C0065		1		K
	. . 041A4104	2	EA	.1uf,63v F CAP	807C0065		1		K
	. . 041A4224	1	EA	.22UF 63V F CAP	807C0065		1		K
	. . 11022101	1	EA	100 1/4W 5% CF RES	807C0065		1		K
	. . 11022102	1	EA	1K 1/4W 5% CF RES	807C0065		1		K
	. . 11022103	4	EA	10K 1/4W 5% CF RES	807C0065		1		K

Servo

ASSY NUMBER 85TR0007

CTR12,DC VERSION

REV

DATE 07/15/99

PAGE: 2

TYPE	PART NUMBER	QTY	UOM	DESCRIPTION	NEXT ASSY	CIR SYM	CODE	BOX	K/B
	. . . 11022104	3	EA	100K 1/4W 5% CF RES	807C0065		I		K
	. . . 11022105	1	EA	10K 1/4W 5% CF RES	807C0065		I		K
	. . . 11022223	3	EA	22K 1/4W 5% CF RES	807C0065		I		K
	. . . 11022272	1	EA	2.7K 1/4W 5% CF RES	807C0065		I		K
	. . . 11022333	3	EA	33K 1/4W 5% CF RESISTOR	807C0065		I		K
	. . . 11022334	2	EA	330K 1/4W 5% CF RES	807C0065		I		K
	. . . 11022392	1	EA	3.9K 1/4W 5% CF RES	807C0065		I		K
	. . . 11022472	5	EA	4.7K 1/4W 5% CF RESISTOR	807C0065		I		K
	. . . 11022474	1	EA	470K 1/4W 5% CF RES	807C0065		I		K
	. . . 11022663	2	EA	68K 1/4W 5% CF RES	807C0065		I		K
	. . . 11032101	1	EA	100 1/2W 5% CF RES	807C0065		I		K
	. . . 11032471	3	EA	470 1/2W 5% CF RES	807C0065		I		K
	. . . 11032560	1	EA	56 1/2W 5% CF RES	807C0065		I		K
	. . . 13N33501	1	EA	500 V TRIM	807C0065		I		K
	. . . 1507233B	1	EA	.53 3W 5% MW RES	807C0065		I		K
	. . . 200A0000	6	EA	1N4148 DIODE	807C0065		I		K
	. . . 210A0002	5	EA	MPS2222	807C0065		I		K
	. . . 211A0003	1	EA	MPS065 TRANSISTOR	807C0065		I		K
	. . . 211A0005	3	EA	MJE2955T TRANSISTOR	807C0065		I		K
	. . . 211A0006	1	EA	MJE3055T TRANSISTOR	807C0065		I		K
	. . . 230A0009	2	EA	LM358 IC (NATIONAL ONLY)	807C0065		I		K
	. . . 231A0003	1	EA	74LS00 IS	807C0065		I		K
	. . . 231A0011	1	EA	74LS123 IC (NOT MOTOROLA)	807C0065		I		K
	. . . 231A0023	1	EA	4040 IC	807C0065		I		K
	. . . 231A0025	1	EA	4053 IC ***MCA ONLY***	807C0065		I		K
	. . . 231A0030	1	EA	4065 IC	807C0065		I		K
	. . . 231A0034	1	EA	4013 IC (NATIONAL ONLY)	807C0065		I		K
	. . . 231A0041	1	EA	74LS195 IC	807C0065		I		K
	. . . 407C0065	1	EA	SERVO PCB	807C0065		I		K
	. . . 410A0001	2	EA	SOCKET DIP 6 PIN	807C0065		I		K
	. . . 410A0002	3	EA	SOCKET DIP 14 PIN	807C0065		I		K
	. . . 410A0005	4	EA	SOCKET DIP 16 PIN	807C0065		I		K
	. . . 410A0012	1	EA	HEADER MTA 100 7 POS	807C0065		I		K
	. . . 410A0013	1	EA	HEADER MTA 100 12 POS	807C0065		I		K
	. . . 440A0000	4	EA	INSULATOR TO 220 SIL PAD	807C0065		I		K
	. . . 541C0020	1	EA	MTG PLATE MOTOR BOARD	807C0065		I		K
	. . . 60701124	4	EA	WASHER SHOULDER	807C0065		I		K
	. . . 62103440	4	EA	SCREW PH 4-40 x 3/16 PL	807C0065		I		K
	. . . 62105632	4	EA	SCREW PH PHIL 6-32X5/16PL	807C0065		I		K
A	. . . 807B0076	1	EA	PLAY/CUE/LOGIC PWA	847B0007		I		K
	. . . 006A0103	12	EA	PANASONIC 4300a-ND	807B0076		CX	I	K

-----  
 C37 C38 C39 C40  
 C59  
 -----

. . . 011A5105 12 EA 10UF 50V E CAP 807B0076 C1 1 K

-----  
 C2 C3 C4 C5  
 C22 C28 C29 C34  
 C45 C48 C50  
 -----

. . . 011A5106 7 EA 100F 50V E CAP 807B0076 C20 1 K

-----  
 C25 C31 C34 C35  
 C50 C57  
 -----

ASST NUMBER 85700097

CIR12,DC VERSION

REV

DATE 07/13/93

PAGE: 3

TYPE	PART NUMBER	QTY	UOM	DESCRIPTION	NEXT ASST	CIR SYN	CODE	BOX	K/N
.	011A5225	1	EA	2.2UF 50V E CAP	80780076	C23	1		K
.	011A5226	1	EA	22UF 25V E CAP	80780076	C35	1		K
.	011A5475	2	EA	4.7UF 50V E CAP	80780076	C10	1		K
.	011A5685	1	EA	6.8 UF 50V E CAP 20%	80780076	C27	1		K
.	011A8107	5	EA	100UF 25V E CAP	80780076	C36	1		K
						C42	C43	C44	C46
.	011B5336	3	EA	33UF 25V E CAP	80780076	C7	1		K
						C8			
						C33			
.	031A3101	6	EA	100pf S CAP	80780076	C24	1		K
						C26	C49	C51	C52
						C53			
.	041A3102	2	EA	.001uf,50v CAP	80780076	C13	1		K
						C14			
.	041A3103	4	EA	CAP.01/63/5	80780076	C6	1		K
						C9	C11	C12	
.	041A4104	3	EA	.1uf,63v F CAP	80780076	C21	1		K
						C41			
						C58			
.	041A4472	3	EA	.0047UF 63V F CAP	80780076	C15	1		K
						C16			
						C32			
.	041A4473	3	EA	.047uf, 63vF CAP	80780076	C17	1		K
						C18			
						C19			
.	11022102	7	EA	1K 1/4W 5% CF RES	80780076	13	1		K
						54	78	79	82
						83	R11		
.	11022103	7	EA	10K 1/4W 5% CF RES	80780076	21	1		K
						39	42	59	66
						80	R14		
.	11022104	3	EA	100K 1/4W 5% CF RES	80780076	50	1		K
						55			
						R49			
.	11022105	3	EA	1M 1/4W 5% CF RES	80780076	48	1		K
						61			



ASSY NUMBER 85780007

CTR12,DC VERSION

REV

DATE 07/13/99

PAGE: 4

TYPE	PART NUMBER	QTY	UOM	DESCRIPTION	NEXT ASSY	CIR SYN	CODE	BOX	K/N
							R47		
.	11022114	1	EA	RES,110K,1/4W,5%,CF	80780076	R12	1		K
.	11022121	2	EA	RES,120 OHM,1/4W,5%,CF	80780076	73	1		K
							R89		
.	11022152	3	EA	1.5K 1/4W 5% CF RES	80780076	34	1		K
							62		
							R28		
.	11022154	4	EA	150K 1/4 5% CF RES	80780076	35	1		K
						-----			
						60	71	75	
						-----			
.	11022164	1	EA	RES 160K, 1/4W, 5%, CF	80780076	R10	1		K
.	11022204	1	EA	RES 200K 1/4W 5% CF	80780076	R25	1		K
.	11022221	4	EA	220 1/4W 5% CF RES	80780076	18	1		K
						-----			
						44	64	65	
						-----			
.	11022222	5	EA	2.2K 1/4W 5% CF RES	80780076	15	1		K
						-----			
						16	36	40	84
						-----			
.	11022224	1	EA	220K, 1/4W 5%	80780076	R31	1		K
.	11022275	1	EA	27K 1/4W 5% CF RES	80780076	R32	1		K
.	11022331	1	EA	3300HM 1/4W 5% RESISTOR	80780076	R30	1		K
.	11022332	3	EA	3.3K 1/4W 5% CF RES	80780076	53	1		K
							56		
							72		
.	11022333	2	EA	33K 1/4W 5% CF RESISTOR	80780076	67	1		K
							68		
.	11022334	1	EA	330K 1/4W 5% CF RES	80780076	R58	1		K
.	11022391	1	EA	330 1/4W 5% CF RES	80780076	R38	1		K
.	11022392	2	EA	3.9K 1/4W 5% CF RES	80780076	26	1		K
							81		
.	11022393	2	EA	RES 39K 1/4W 5% CF	80780076	37	1		K
							41		
.	11022473	2	EA	47K 1/4W 5% CF RES	80780076	63	1		K
							76		
.	11022682	2	EA	6.8K 1/4W 5% CF RES	80780076	24	1		K

TYPE	PART NUMBER	QTY	UOM	DESCRIPTION	NEXT ASSY	CIR	SYM	CODE	BOX	K/P
								77		
.	11022755	2	EA	75K 1/4W 5% CF RES	80780076		70	1		K
							74			
.	11022821	2	EA	820 1/4W 5% CF RES	80780076		23	1		K
							57			
.	11032101	2	EA	100 1/2W 5% CF RES	80780076		51	1		K
							52			
.	12020105	4	EA	10K,1/4W 1% RESISTOR	80780076		17	2		K
-----										
							19	43	45	
-----										
.	1202051N	2	EA	5.11K 1/4W 1% MF RES	80780076		20	1		K
							46			
.	13M33103	2	EA	10K V TRIM	80780076		4	1		K
							5			
.	13M33202	3	EA	2K V TRIM	80780076		R1	1		K
							R2			
							R3			
.	13M33203	2	EA	20K V TRIM	80780076		R7	1		K
							R9			
.	13M33504	2	EA	500K V TRIM	80780076		R6	1		K
							R8			
.	13T33202	5	EA	2K H TT TRIM	80780076		R22	1		K
							R29			
							R33			
.	13T33502	1	EA	5K H TRIM	80780076		R27	1		K
.	14411103	2	EA	RES. NET., 10K-4	80780076		RN2	1		K
							RN9			
.	14411104	2	EA	RES. NET. 100K-4	80780076		RN4	1		K
							RN5			
.	14411105	1	EA	RES. NET., 1M-4	80780076		RN8	1		K
.	14411392	2	EA	RES NET 3.9K-4	80780076		RN6	1		K
							RN7			
.	14411474	1	EA	RES. NET., 470K-4	80780076		RN3	1		K
.	19811103	1	EA	RESISTOR NETWORK 10K-9	80780076		RN1	1		K

ASSY NUMBER 85780007

CTK12,DC VERSION

REV

DATE 07/13/99

PAGE: 6

TYPE	PART NUMBER	QTY	UOM	DESCRIPTION	NEXT ASSY	CIR SYM	CODE	BOX	K/N
.	. 200A0000	34	EA	1N4148 DIODE	80780076	D1	1		K
-----									
						D2	D3	D4	D5
						D6	D7	D8	D9
						D10	D11	D12	D14
						D15	D16	D17	D18
						D19	D20	D21	D22
						D23	D24	D25	D26
						D27	D28	D30	D31
						D32	D35	D36	D37
						D38			
-----									
.	. 201A0000	2	EA	1N4005 DIODE	80780076	D33	1		K
						D34			
.	. 204A0005	1	EA	DIODE, ZENER, 27V,	80780076	D13	1		K
.	. 210A0002	13	EA	MPS2222	80780076	Q1	1		K
-----									
						Q2	Q3	Q5	Q6
						Q8	Q9	Q10	Q11
						Q12	Q13	Q16	Q18
-----									
.	. 211A0002	1	EA	TRANSISTOR NPN T1P120	80780076	Q15	1		K
.	. 211A0004	1	EA	D4582 TRANSISTOR	80780076	Q14	1		K
.	. 220A0000	5	EA	TRANSISTOR P FET P1088E	80780076	Q4	1		K
-----									
						Q7	Q17	Q19	Q20
-----									
.	. 230A0000	3	EA	5532 DUAL OP-AMP IC	80780076	U4	1		K
						U7			
						U13			
.	. 230A0005	1	EA	LM3300 IC	80780076	U8	1		K
.	. 230A0008	1	EA	LF353 IC	80780076	U12	1		K
.	. 230A0010	2	EA	RC4558 IC	80780076	U1	1		K
						U2			
.	. 231A0028	2	EA	4081 IC	80780076	U3	1		K
						U10			
.	. 231A0030	1	EA	4069 IC	80780076	U6	1		K
.	. 231A0033	1	EA	72042 IC	80780076	U5	1		K
.	. 231A0044	1	EA	4044 IC	80780076	U9	1		K
.	. 300A0000	4	EA	INDUCTOR BALUN	80780076	C1	1		K
-----									
						C2	T1	T2	
-----									

ASSY NUMBER 80780007

CTRL2,DC VERSION

REV

DATE 07/13/93

PAGE: 7

TYPE	PART NUMBER	QTY	UOM	DESCRIPTION	NEXT ASSY	CIR SYN	CODE	BOX	K/W
	. . 356A0000	2	EA	RELAY SPDT 12V PC MOUNT	80780076	K1	1		K
						K2			
	. . 40780075	1	EA	PCB,PLAY/CUE/LOGIC	80780076		1		K
	. . 410A0001	6	EA	SOCKET DIP 8 PIN	80780076		1		K
	. . 410A0002	4	EA	SOCKET DIP 14 PIN	80780076		1		K
	. . 410A0003	2	EA	SOCKET DIP 16 PIN	80780076		1		K
	. . 418A0004	1	EA	RECEPTACLE 9 PIN D	80780076		1		K
	. . 41GA0001	1	EA	CONNECTOR HARDWARE	80780076		1		K
	. . 420A0001	1	EA	WIRE BUS 22 AWG	80780076		1		K
	. . 423A265N	1	EA	WIRE STRANDED 26 AWG GRN	80780076		1		K
	. . 426A0001	6	EA	WIRE 2 COND W/SHIELD	80780076		1		K
	. . 44SA0000	1	EA	TUBING HEAT SHRINK 3/16	80780076		1		K
	. . 5ABA0007	2	EA	BOARD EJECTOR	80780076		1		K
	. . 60120440	2	EA	NUT HEX 4-40 STEEL PLATE	80780076		1		K
	. . 60C11400	2	EA	L WASHER I.T. #4	80780076		1		K
	. . 62105440	2	EA	SCREW PH PHIL 4-40X5/16	80780076		1		K
	. . 837A0022	1	EA	SHIELDED JUMPER ASM	80780076		1		K
	. 807G0105	1	EA	MOTHER BD ASM,CTRL DC	84780007		5		K
	. . 006A6105	6	EA	PANASONIC 4300a-ND	807G0105	C10	1		K
						C15	C16	C17	C18
						C19			
	. . 011A5688	3	EA	CAP 6800 UF 50V	807G0105	C1	1		K
						C2			
						C3			
	. . 011A6107	6	EA	100UF 25V B CAP	807G0105	C4	1		K
						C5	C6	C7	C8
						C9			
	. . 031A250A	1	EA	5pf CAPACITOR	807G0105	C11	1		K
	. . 031A3221	3	EA	220pf, S CAP	807G0105	C12	1		K
						C13			
						C14			
	. . 11022105	9	EA	10K 1/4W 5% CF RES	807G0105	R1	1		K
						R2	R3	R4	R9
						R11	R12	R13	R14
	. . 11022104	1	EA	100K 1/4W 5% CF RES	807G0105	R10	1		K
	. . 11022225	3	EA	22K 1/4W 5% CF RES	807G0105	R16	1		K
						R17			
						R18			
	. . 11022471	1	EA	470 1/4W 5% CF RES	807G0105	R6	1		K
	. . 11022472	1	EA	4.7K 1/4W 5% CF RESISTOR	807G0105	R7	1		K
	. . 11022473	1	EA	47K 1/4W 5% CF RES	807G0105	R5	1		K

*MB*

ASSY NUMBER 857B0007

CTR12,DC VERSION

REV

DATE 07/13/99

PAGE: 8

TYPE	PART NUMBER	QTY	UOM	DESCRIPTION	NEXT ASSY	CTR	SYM	CODE	BOX	K/N
.	. 11022474	1	EA	470K 1/4W 5% CF RES	807G0105		R	1		K
							R8			
.	. 14411392	1	EA	RES NET 3.9K-4	807G0105		R15	1		K
.	. 200A0000	1	EA	1N4148 DIODE	807G0105		D14	1		K
.	. 201A0000	5	EA	1N4005 DIODE	807G0105		D5	1		K
							D6	D11	D12	D13
.	. 201A0002	8	EA	6A4 DIODE	807G0105		D1	1		K
							D2	D3	D4	D7
							D8	D9	D10	
.	. 204A0002	2	EA	1N4733A DIODE	807G0105		CR1	1		K
							CR2			
.	. 210A0002	1	EA	WPS2222	807G0105		Q2	1		K
.	. 210A0005	2	EA	2N4403 TRANSISTOR	807G0105		Q1	1		K
							Q3			
.	. 230A0010	1	EA	RC4558 IC	807G0105		2	1		K
.	. 230A0406	1	EA	IC, MC4053	807G0105		U8	1		K
.	. 231A0023	1	EA	4040 IC	807G0105		U1	1		K
							U6			
.	. 231A0403	1	EA	IC 74HC00	807G0105		U6	1		K
.	. 231A0404	1	EA	IC 74HC4040	807G0105		U7	1		K
.	. 231A0405	1	EA	IC 74HC4060	807G0105		U3	1		K
.	. 231A0412	2	EA	IC 74HC163	807G0105		U4	1		K
							U5			
.	. 250A0238	1	EA	LED, GREEN	807G0105		D15	1		K
.	. 250A0239	1	EA	LED, RED	807G0105		D16	1		K
.	. 3700003	1	EA	REGULATOR MC78H05CT	807G0105		VR5	5		K
.	. 384A0000	1	EA	CRYSTAL 16.432MHZ MC18U	807G0105		Y1	1		K
.	. 407G0105	1	EA	PCB, MOTHER BD CTR10 DC	807G0105		PCB	5		K
.	. 410A0001	1	EA	SOCKET DIP 8 PIN	807G0105		SO2	1		K
.	. 410A0002	1	EA	SOCKET DIP 14 PIN	807G0105		SO6	1		K

TYPE	PART NUMBER	QTY	UOM	DESCRIPTION	NEXT ASSY	CIR	SYM	CODE	BOX	R/R
	. . 410A0003	8	EA	SOCKET DIP 16 PIN	807G0105		J2	1		K
							J1	S01	S03	S04
							S05	S07	S08	
	. . 410A0009	4	EA	SOCKET TRANSISTOR	807G0105		SVR1	1		K
							SVR2	SVR3	SVR4	
	. . 412A0001	1	EA	CONN EDGE 28 POS DUAL	807G0105		J4	1		K
	. . 416A0006	1	EA	12 PIN MR HEADER	807G0105		J5			
	. . 416A0008	1	EA	HEADER MTA 100 2 POS	807G0105		P2	1		K
	. . 416A0009	1	EA	HEADER MTA 100 3 POS	807G0105		P4	1		K
	. . 416A0011	1	EA	HEADER MTA 100 6 POS	807G0105		P5	1		K
	. . 416A0012	1	EA	HEADER MTA 100 7 POS	807G0105		P8	1		K
	. . 416A0016	2	EA	HEADER .079 9 POS	807G0105		P5	1		K
							P6	1		K
							P7			
	. . 418A0003	1	EA	RECEPTACLE 50 PIN D	807G0105		J3	1		K
	. . 4700036	2	EA	TRANSISTOR MPS-6599	807G0105		Q4	5		K
							Q5			
	. . 525A0105	1	EA	SHIELD CTR10 MTR BD	807G0105			5		K
	. . 541A0050	1	EA	HEAT SINK , T0220 HD MT	807G0105		HS1	5		K
	. . 60120440	2	EA	NUT HEX 4-40 STEEL PLATE	807G0105		N8	1		K
							N9			
	. . 60120632	1	EA	NUT HEX 6-32 STEEL PLATE	807G0105		N3	1		K
	. . 60C11400	2	EA	L'WASHER I.T. #4	807G0105		N6	1		K
							N7			
	. . 60C11600	1	EA	L'WASHER I.T. #6	807G0105		N2	1		K
	. . 62104440	2	EA	SCREW,PH PAN 4-40x1/4 SP	807G0105		N4	1		K
							N5			
	. . 62104632	1	EA	SCREW PH PHIL 6-32X1/4 PL	807G0105		N1	1		K
	. 827A0018	1	EA	ASH, FRONT PANEL,CTR11/12	847B0007			1		K
	. . 11022130	3	EA	13 1/4W 5% CF RES	827A0018			1		K
	. . 11032681	3	EA	680 1/2 5% CF RES	827A0018			1		K
	. . 250A0004	3	EA	LED GREEN	827A0018			1		K
	. . 260A0001	3	EA	LAMP 382	827A0018			1		K

*FRT Panel*

ASSY NUMBER 857B0007

CTRL2,DC VERSION

REV

DATE 07/15/99

PAGE: 10

TYPE	PART NUMBER	QTY	UOM	DESCRIPTION	NEXT ASSY	CTR SYN	CODE	BOX	K/N
	. . . 364A0005	3	EA	SWITCH PUSH BUTTON	827A0018		1		K
	. . . 364A0006	1	EA	LENS - SWITCH WHITE	827A0018		1		K
	. . . 364A0007	1	EA	LENS - SWITCH RED	827A0018		1		K
	. . . 364A0008	1	EA	LENS - SWITCH GREEN	827A0018		1		K
	. . . 407A0085	1	EA	PCB, SWITCH P	827A0018		1		K
	. . . 410A0003	1	EA	SOCKET DIP 16 PIN	827A0018		1		K
	. . . 532B0007	1	EA	FRONT PANEL CTRL2	827A0018		1		K
	. . . 581A0011	1	EA	OVERLAY,SWITCH, PL	827A0018		1		K
A	. . . 827A0021	1	EA	ASM, HEAT SINK CTRL0	847B0007		1		K
	. . . 230A0012	2	EA	LM7815CT +15V REGULATOR	827A0021		1		K
	. . . 230A0014	1	EA	LM7915CT -15V REGULATOR	827A0021		1		K
	. . . 230A0016	1	EA	IC, AN7916, 18V REG	827A0021		1		K
	. . . 440A0000	4	EA	INSULATOR TO 220 SIL PAD	827A0021		1		K
	. . . 541B0003	1	EA	HEAT SINK, MOTHER BD,	827A0021		1		K
	. . . 60701124	4	EA	WASHER SHOULDER	827A0021		1		K
	. . . 62103440	4	EA	SCREW,PH 4-40 x 3/16 PL	827A0021		1		E
A	. . . 827A0026	1	EA	ASM DRCK CTRL0	847B0007		1		K
	. . . 320A0000	1	EA	SOLENOID	827A0026		1		K
	. . . 415A0011	1	EA	HOUSING MTA 100 2 COND	827A0026		1		K
	. . . 526A0000	1	EA	STUD SOLENOID	827A0026		1		K
	. . . 531B0002	1	EA	DECK PLATE CTRL0 100A ESD	827A0026		1		K
	. . . 543B0011	1	EA	STOP ACTUATOR	827A0026		1		K
	. . . 543D0008	1	EA	ACTUATOR CART	827A0026		1		K
	. . . 5A6A0000	1	EA	CHAIN SPROCKET .1475	827A0026		1		K
	. . . 5A1A0001	1	EA	FOOT	827A0026		1		K
	. . . 5A3A0000	4	EA	ROLLER CART HOLD DOWN	827A0026		1		K
	. . . 5AAB0002	1	EA	SPROCKET SOLENOID	827A0026		1		K
	. . . 5ABB0003	2	EA	BEARING HOLD DOWN SHAFT	827A0026		1		K
	. . . 5B5A0001	4	EA	RETAINER RING 3/16 SHAFT	827A0026		1		K
	. . . 5B4A0000	1	EA	HEADED SPIRAL PIN	827A0026		1		K
	. . . 5B6A0003	1	EA	SHAFT CART HOLD DOWN	827A0026		1		K
	. . . 5B8B0001	1	EA	SHAFT VERT BALL BEARING	827A0026		1		K
	. . . 5B8K0002	1	EA	SHAFT HORIZONTAL	827A0026		1		K
	. . . 5E1A0002	1	EA	SPRING EXTENSION SOLENOID	827A0026		1		K
	. . . 5E1K0001	1	EA	SPRING EXTENSION SWITCH	827A0026		1		K
	. . . 5E2A0002	1	EA	SPRING, CART HOLD DOWN	827A0026		1		K
	. . . 60020032	1	EA	NUT HEX 10-32 STL PL	827A0026		1		K
	. . . 60107000	4	EA	WASHER .31X.191X.025 SS	827A0026		1		K
	. . . 60107001	1	EA	WASHER .53X.13X.05 SS	827A0026		1		K
	. . . 60107002	2	EA	WASHER .50X.252X.01 SS	827A0026		1		K
	. . . 60C11000	3	EA	L'WASHER I.T. #10	827A0026		1		K
	. . . 60C11200	1	EA	L'WASHER I.T. #2	827A0026		1		K
	. . . 60C11600	3	EA	L'WASHER I.T. #6	827A0026		1		K
	. . . 62103256	1	EA	SCREW PH PH16 2-56X3/16ZP	827A0026		1		K
	. . . 62103440	1	EA	SCREW,PH 4-40 x 3/16 PL	827A0026		1		K
	. . . 62104440	2	EA	SCREW,PH PAN 4-40x1/4 SF	827A0026		1		K
	. . . 62105440	1	EA	SCREW PH PH16 4-40X5/16	827A0026		1		K
	. . . 62105632	2	EA	SCREW PH PH16 6-32X5/16PL	827A0026		1		K
	. . . 62106032	1	EA	SCREW PH PH16 6-32X3/8 LP	827A0026		1		K
	. . . 62106032	2	EA	SCREW PH PH16 10-32X.5 SF	827A0026		1		K

TYPE	PART NUMBER	QTY	UOM	DESCRIPTION	NEXT ASSY	CTR STR	CODE	BOX	K/W
	. . . 700A0001	1	EA	GLUE EASTMAN 910 OR EQUIV	827A0026				K
A	. . . 827A0025	1	EA	RIGHT BRACKET ASM CTRLZ	827A0026				K
	. . . 543R0007	1	EA	BRKT CART HOLD DOWN RIGHT	827A0025				K
	. . . 5ABD0003	2	EA	BEARING HOLD DOWN SHAFT	627A0025				K
	. . . 5B2A0010	1	EA	SPACER 1/4X3/8 #4 NYLON	827A0025				K
	. . . 5B2A0011	1	EA	SPACER 1/4X1/2 RED NYL #4	827A0025				K
	. . . 5E2A0002	1	EA	SPRING, CART HOLD DOWN	827A0025				K
	. . . 68703440	2	EA	SCREW RD S; 4-40X3/16 NYL	827A0025				K
	. . . 68708440	3	EA	SCREW RD SL 4-40X3/16 NYLN	827A0025				K
A	. . . 807A0061	1	EA	CART READY PWA, CTRLZ	827A0025				K
	. . . 11032621	1	EA	680 1/2 5% CF RES	807A0061				K
	. . . 271A0001	1	EA	OP550 PHOTO TRANSISTOR	807A0061				K
	. . . 271A0002	1	EA	IR EMITTING DIODE	807A0061				K
	. . . 361A0000	1	EA	SWITCH, SLIDE, SPDT	807A0061				K
	. . . 407D0060	1	EA	CART SCAN PCB	807A0061				K
	. . . 416A0019	1	EA	HEADER, 3 POS RT	807A0061				K
	. . . 420A0001	0	EA	WIRE BUS 22 AWG	807A0061				K
A	. . . 827A0063	1	EA	LEFT BRKT ASM "A"	827A0026				K
	. . . 543F0009	1	EA	BRKT CART HOLD DN LEFT A	827A0063				K
	. . . 565A0000	1	EA	RIVET	827A0063				K
	. . . 562B0001	1	EA	SPRING CART GUIDE	827A0063				K
	. . . 827A0065	1	EA	ACTUATOR "A" REAR SHAFT	827A0026				K
A	. . . 827A0404	1	EA	TRANSFORMER ASM, TORROID	847B0007				K
	. . . 311B0404	1	EA	TRANSFORMER, TORROID	827A0404				K
	. . . 414A0007	7	EA	TERMINAL, MR	827A0404	JP2			K
	. . . 414A0014	3	EA	TERMINAL, H IPSN 18-26GA	827A0404	JP1			K
	. . . 415A0015	1	EA	HOUSING, 12 PIN MR	827A0404	J2			K
	. . . 415A0020	1	EA	CONN. 4 PIN	827A0404	J1			K
	. . . 423A189H	0	EA	WIRE STRANDED 18GA WHITE	827A0404				K
A	. . . 827B0024	1	EA	ASN, REAR PANEL, CTRLZ	847B0007				K
	. . . 360A0001	1	EA	SWITCH TOGGLE	827B0024				K
	. . . 371A0001	1	EA	FUSE 1A SLO BLO	827B0024				K
	. . . 415A0000	1	EA	CONNECTOR AC 3 PIN RECEIPT	827B0024				K
	. . . 414A0007	3	EA	TERMINAL, MR	827B0024				K
	. . . 415A0014	1	EA	HOUSING, 4 PIN MR	827B0024				K
	. . . 417A0004	1	EA	HOLE PLUG	827B0024				K
	. . . 423A220N	20	IN	WIRE STRANDED 22 AWG BLK	827B0024				K
	. . . 423A225N	16	IN	WIRE STRANDED 22 AWG GRN	827B0024				K
	. . . 423A229N	12	IN	WIRE STRANDED 22 AWG WHT	827B0024				K
	. . . 430A0000	1	EA	FUSE HOLDER PANEL MOUNT	827B0024				K
	. . . 445A0000	2	EA	TUBING HEAT SHRINK 3/16	827B0024				K
	. . . 445A0001	1	EA	TUBING HEAT SHRINK 1/8	827B0024				N
	. . . 445A0002	1	EA	TUBING HEAT SHRINK 3/4	827B0024				K
	. . . 541B0035	1	EA	REAR PANEL, CTRLZ	827B0024				K
	. . . 5A2A0000	3	EA	TY WRAP 1/16 TO 2" DIA	827B0024				K
	. . . 5A2A0006	1	EA	GROUND LUG	827B0024				K

*Xferm*

*Rear*

*640545*





TYPE	PART NUMBER	QTY	UOM	DESCRIPTION	NEXT ASSY	CIR SYM	CODE	BOX	R/N
	5A5A0001	2	EA	CARD GUIDE #250 RIVAR	827B0024				K
	60033632	1	EA	NUT THUMB 6-32	827B0024				K
	60120632	3	EA	NUT HEX 0-32 STEEL PLATE	827B0024				K
	60C11600	2	EA	L'WASHER I.T. #6	827B0024				K
	82103632	2	EA	SCREW PH PHIL 6-32X3/16PL	827B0024				K
	82106632	2	EA	SCREW PH PHIL 6-32X3/8 ZP	827B0024				K
	82106632	1	EA	SCREW PH PHIL 6-32X1/2 LG	827B0024				K
A	827C0409	1	EA	MOTOR ASM, CTR DC	847B0007			5	K
	828C0430	1	EA	DC MOTOR, CLIFTON	827C0409			5	K
A	807F0420	1	EA	TACH ASSY	827C0409			1	K
	11022332	1	EA	3.3K 1/4W 5% CF RKS	807F0420			1	K
	2010001	4	EA	STANDOFF P8H KFE440-8	807F0420			5	K
	272A0402	1	EA	OPTO SENSOR, SFH 900-2	807F0420			1	K
	3910022	1	EA	RES HF 150 OHM 1/4W 1%	807F0420			5	K
	407F0420	1	EA	TACH PCB, CTR90/100	807F0420			5	K
	414A0013	5	EA	CONNECTOR, BUTT SPLICE	807F0420			1	K
	423A221N	1	EA	WIRE 22 AWG BRN	807F0420			1	K
	423A222N	1	IN	WIRE STRANDED 22 AWG RED	807F0420			1	K
	423A223N	1	EA	WIRE STRANDED 22 AWG GRN	807F0420			1	K
	5A8A0000	1	EA	GROMMET RUBBER	807F0420			1	K
	5E2A0402	4	EA	SPRING, PENETRATION	807F0420			1	K
	82103440	4	EA	SCREW PH 4-40 x 3/16 PL	807F0420			1	K
A	827F0401	1	EA	HEAD BRIDGE ASSY, PLASTIC	847B0007			5	K
	501B0402	2	EA	HEAD LOCKING BLOCK	827F0401			1	K
	501B0400	2	EA	BEARING BLOCK, PLASTIC	827F0401			5	K
	502C0400	2	EA	HEAD SHAFT CTR90	827F0401			5	K
A	512F0400	1	EA	HEAD BRIDGE FINISHED	827F0401			5	K
	512F1400	1	EA	HEAD BRIDGE (PLATED)	512F0400			5	N
	512F2400	1	EA	HEAD BRIDGE (PLASTIC)	512F0400			5	N
	570B0400	2	EA	HEIGHT ZENITH BEAM	827F0401			1	K
	570B0402	2	EA	THRUST PLATE, CTR90	827F0401			1	K
	570C0401	2	EA	HEAD CLAMP, CTR 90	827F0401			1	K
	571B0405	2	EA	AZIMUTH BEAM	827F0401			1	K
	5ABA0001	1	EA	TAPE GUIDE CURVED	827F0401			1	K
	5ABA0002	1	EA	TAPE GUIDE STRAIGHT	827F0401			1	K
	5B6A0400	2	EA	BALL 3/16	827F0401			1	K
	5K204148	2	EA	SPRING COMP .1480 X 1/4	827F0401			1	K
	5E2A0400	4	EA	SPRING, ZENITH BEAM	827F0401			1	K
	5K2A0401	2	EA	SPRING, AZIMUTH	827F0401			1	K
	5E2A0402	2	EA	SPRING, PENETRATION	827F0401			1	K
	60100400	4	EA	#4 FLAT WASHER STL PLATE	827F0401			1	K
	60500231	2	EA	FLAT WASHER SS .187 OD	827F0401			1	K
	045A0440	4	EA	SCREW FL PHIL 4-40X1/4 SS	827F0401			1	K
	60206640	4	EA	SCRW 5-40X1/2 82 FH SOC	827F0401			1	K
	60196440	4	EA	SCRW 4-40X3/8 P8H STL	827F0401			1	K
	60204632	2	EA	SCRW SET 8-32X1/4 FLT TIP	827F0401			1	K
	60206632	2	EA	SCRW SET 8-32X3/8 FLT TIP	827F0401			1	K
	6720A250	4	EA	SCRW SOC HC 2-56X5/8 BLK	827F0401			1	K
	67210250	4	EA	SCRW SOC HC 2-56 X 1 BLK	827F0401			1	K
A	837A0011	1	EA	ASM READY CABLE CTRLZ	847B0007			1	K

Match

Head Bridge

TYPE	PART NUMBER	QTY	UOH	DESCRIPTION	EXT ASSY	GR SYM	CODE	ROA	R/A
	. . 415A0000	2	EA	CONNECTOR 5 TERMINAL MTA	837A0011		1		K
	. . 423A223H	36	IN	WIRE STRANDED 22 AWG WHT	837A0011		5		K
	. . 5A2A0000	4	EA	TY WRAP 1/16 TO 2" DIA	837A0011		1		K
A	. 837B0004	1	EA	HEAD CABLE S	847B0007		1		K
	. . 414A0000	9	EA	TERMINAL FOR .079 HOUSING	837B0004		1		K
	. . 415A0010	1	EA	HOUSING .079 9 POSITION	837B0004		1		K
A	. . 837A0021	5	EA	HD CBL BASIC	837B0004		1		K
	. . . 414A0010	2	EA	TERMINAL	837A0021		1		K
	. . . 426A0001	10	EA	WIRE 2 COND W/SHIELD	837A0021		1		K
	. . . 44SA0000	2	EA	TUBING HEAT SHRINK 3/16	837A0021		1		K
	. . . 44SA0001	2	EA	TUBING HEAT SHRINK 1/8	837A0021		1		N
A	. 837D0010	1	EA	SERVU CABLE	847B0007		1		K
	. . 415A0013	2	EA	HOUSING 9 COND	837D0010		1		K
	. . 41FA0000	4	EA	KEY - CONNECTOR	837D0010		1		K
	. . 423A223H	84	IN	WIRE STRANDED 22 AWG WHT	837D0010		5		K
	. . 5A2A0000	5	EA	TY WRAP 1/16 TO 2" DIA	837D0010		1		K
A	. PRK-2	1	EA	PINCH ROLLER KIT	847B0007		5		K
	. . 5A3C0002	1	EA	PINCH ROLLER	PRK-2		1		K
	. . 5B1A0003	1	EA	BALL BEARING	PRK-2		1		K
	. . 5B3A0001	1	EA	RETAINER RING 3/16 SHAFT	PRK-2		1		K
	. . 60107065	2	EA	WASHR SS .3100X191DX.065	PRK-2		1		K
	. . 60302124	2	EA	WAVY WASHER	PRK-2		1		K

END OF JOB

CTR 14

Record

RTD&LIPAC CORPORATION - INDENTED BILL OF MATERIAL

ASSY NUMBER 85780009

CTR 14 DC, FINAL ASN

REV

DATE 07/13/99

PAGE: 1

TYPE	PART NUMBER	QTY	UOM	DESCRIPTION	NEXT ASSY	CIR SYM	CODE	BOX	K/M
	54180024	1	EA	BOTTOM COVER	85780009		1		K
	54100016	1	EA	TOP COVER "A"	85780009		1		K
	563A0000	1	EA	BUTTON TOP COVER	85780009		1		K
	5A1A0000	4	EA	RUBBER FOOT	85780009		1		K
	5b2A0014	2	EA	SPCR SS 1/4"ODX3/16"LG X	85780009		1		K
	60100600	2	EA	#6 FLAT WASHER STL PLATE	85780009		1		K
	60507000	2	EA	WASHER 1/4 ID X 3/8 OD SS	85780009		1		K
	60C11600	4	EA	L'WASHER I.T. #6	85780009		1		K
	62103632	2	EA	SCREW PH PHIL 6-32X3/16PL	85780009		1		K
	62105632	4	EA	SCREW PH PHIL 6-32X5/16PL	85780009		1		K
	62108632	2	EA	SCREW PH PHIL 6-32X1/2 LG	85780009		1		K
	A 84780009	1	EA	TOP ASN, CTR14 DC	85780009		1		K
	. 340A0002	1	EA	PLAY HEAD STEREO	84780009		1		K
	. 340A0003	1	EA	RECORD HEAD STEREO	84780009		1		K
	. 42CA0001	2	EA	RIBBON CABLE ASSEMBLY	84780009		1		K
	. 525A0008	1	EA	PARTITION COVER, CTR10	84780009		1		K
	. 525C0400	1	EA	MOTOR SHIELD	84780009		1		N
	. 525C0401	1	EA	HEAD SHIELD, CTR10'S	84780009		1		K
	. 541P0034	1	EA	PARTITION SHIELD, CTR10	84780009		1		K
	. 541C0018	1	EA	PARTITION A	84780009		1		K
	. 541F0022	1	EA	SIDE PANEL LEFT CTR	84780009		5		K
	. 541F0023	1	EA	SIDE PANEL RIGHT	84780009		1		N
	. 561A0007	1	EA	OVERLAY LOGO FRONT PANEL	84780009		1		K
	. 561A0012	1	EA	FRONT PANEL OVERLAY	84780009		1		K
	. 561A0013	1	EA	LABEL, PARTITION COVER	84780009		1		K
	. 561B0009	1	EA	OVERLAY, VU CTR14	84780009		1		K
	. 5A4A0002	2	KA	CARD GUIDE	84780009		1		K
	. 5ABA0008	1	EA	CAP THUMB SCREW	84780009		1		K
	. 60100400	1	EA	#4 FLAT WASHER STL PLATE	84780009		1		K
	. 60716632	4	EA	NUT CAPTIVE	84780009		1		K
	. 62104440	1	EA	SCREW, PH PAN 4-40x1/4 SP	84780009		1		K
	. 62104632	10	EA	SCREW PH PHIL 6-32X1/4 PL	84780009		1		K
	. 6210C032	2	EA	SCREW PH PHIL 10-32X3/4SP	84780009		1		K
	. 64505632	4	EA	SCREW FL PHIL 6-32X3/16 SS	84780009		1		K
	. 64504632	20	EA	SCREW, PH FL 6-32x1/4 SP	84780009		1		K
	. 64504832	4	EA	SCREW FL PHIL 8-32X1/4 SS	84780009		1		K
	. 64506032	4	EA	SCREW, PH PH, 10-32x3/8 SS	84780009		1		K
	. 6Y204632	1	EA	SCRW SOC HD CAP 6-32X1/4	84780009		1		K
	. 6Y216632	2	EA	SCRW SOC HC 6-32X1 3/8 BK	84780009		1		K
	. 807C0065	1	EA	SERVO PWA	84780009		1		K
	. . 006A0103	6	EA	PANASONIC 4300a-ND	807C0065		1		K
	. . 006B4100	2	EA	CAP, 10PF D	807C0065		1		K
	. . 011A5105	2	EA	1UF 50V E CAP	807C0065		1		K
	. . 011A5106	6	EA	10UF 50V E CAP	807C0065		1		K
	. . 011A8107	1	KA	100UF 25V E CAP	807C0065		1		K
	. . 041A3102	1	EA	.001uf, 50v CAP	807C0065		1		K
	. . 041A3103	2	EA	CAP. 01/63/5	807C0065		1		K
	. . 041A4104	2	EA	.1uf, 63v F CAP	807C0065		1		K
	. . 041A4224	1	KA	.22UF 63V F CAP	807C0065		1		K
	. . 11022101	1	EA	100 1/4W 5% CF RS	807C0065		1		K

700

2wb

FIDELIFAC CORPORATION - INDENTED BILL OF MATERIAL

ASSY NUMBER 857B0009

CTR 14 DC, FINAL ASN

REV

DATE 07/13/99

PAGE: 2

TYPE	PART NUMBER	QTY	UOM	DESCRIPTION	NEXT ASSY	CLR SYM	CODE	BOX	K/R
. .	11022102	1	EA	1K 1/4W 5% CF RES	807C0065		1		K
. .	11022103	4	EA	10K 1/4W 5% CF RES	807C0065		1		K
. .	11022104	3	EA	100K 1/4W 5% CF RES	807C0065		1		K
. .	11022105	1	EA	1M 1/4W 5% CF RES	807C0065		1		K
. .	11022223	3	EA	22K 1/4W 5% CF RES	807C0065		1		K
. .	11022272	1	EA	2.7K 1/4W 5% CF RES	807C0065		1		K
. .	11022333	3	EA	33K 1/4W 5% CF RESISTOR	807C0065		1		K
. .	11022334	2	EA	530K 1/4W 5% CF RES	807C0065		1		K
. .	11022392	1	EA	3.9K 1/4W 5% CF RES	807C0065		1		K
. .	11022472	5	EA	4.7K 1/4W 5% CF RESISTOR	807C0065		1		K
. .	11022474	1	EA	470K 1/4W 5% CF RES	807C0065		1		K
. .	11022583	2	EA	68K 1/4W 5% CF RES	807C0065		1		K
. .	11032101	1	EA	100 1/2W 5% CF RES	807C0065		1		B
. .	11032471	3	EA	470 1/2W 5% CF RES	807C0065		1		K
. .	11032560	1	EA	56 1/2W 5% CF RES	807C0065		1		K
. .	13M33501	1	EA	500 V TRIM	807C0065		1		K
. .	13072333B	1	EA	.33 3W 5% WW RES	807C0065		1		K
. .	200A0000	6	EA	1N4148 DIODE	807C0065		1		K
. .	210A0002	5	EA	MPS2222	807C0065		1		K
. .	211A0003	1	EA	MPS005 TRANSISTOR	807C0065		1		K
. .	211A0005	3	EA	MJE2955T TRANSISTOR	807C0065		1		K
. .	211A0006	1	EA	M3K3055T TRANSISTOR	807C0065		1		K
. .	230A0009	2	EA	LM358 IC (NATIONAL ONLY)	807C0065		1		K
. .	231A0003	1	EA	74LS00 IS	807C0065		1		K
. .	231A0011	1	EA	74LS123 IC (NOT MOTOROLA)	807C0065		1		K
. .	231A0023	1	EA	4040 IC	807C0065		1		K
. .	231A0025	1	EA	4053 IC ***RCA ONLY***	807C0065		1		K
. .	231A0030	1	EA	4069 IC	807C0065		1		K
. .	231A0034	1	EA	4013 IC (NATIONAL ONLY)	807C0065		1		K
. .	231A0041	1	EA	74LS195 IC	807C0065		1		K
. .	407C0065	1	EA	SBEVO PCB	807C0065		1		K
. .	410A0001	2	EA	SOCKET DIP 8 PIN	807C0065		1		K
. .	410A0002	3	EA	SOCKET DIP 14 PIN	807C0065		1		K
. .	410A0003	4	EA	SOCKET DIP 16 PIN	807C0065		1		K
. .	410A0012	1	EA	HEADER MTA 100 7 POS	807C0065		1		K
. .	410A0013	1	EA	HEADER MTA 100 12 POS	807C0065		1		K
. .	440A0000	4	EA	INSULATOR TO 220 SIL PAD	807C0065		1		K
. .	541C0020	1	EA	MTG PLATE MOTOR BOARD	807C0065		1		K
. .	60701124	4	EA	WASHER SHOULDER	807C0065		1		K
. .	62103440	4	EA	SCREW,PH 4-40 x 3/16 PL	807C0065		1		K
. .	62105032	4	EA	SCREW PH PHIL 6-32X5/16PL	807C0065		1		K
. .	807C0061	1	EA	RECORD AMP STEREO	847B0009		1		K
. .	006A0102	4	EA	CAP. .001UF D	807C0081		1		K
. .	011A5105	5	EA	10UF 50V E CAP	807C0081		1		K
. .	011A5106	22	EA	100F 50V E CAP	807C0081		1		K
. .	011A6107	9	EA	1000F 25N E CAP	807C0081		1		K
. .	011B5107	2	EA	1000F 10V CAP	807C0061		1		K
. .	031A3101	1	EA	100pf S CAP	807C0081		1		K
. .	031A3102	1	EA	1000PF S CAP	807C0081		1		K
. .	031A3220	4	EA	22PF S CAP	807C0081		1		K

Rec

FIDELIPAC CORPORATION - INDENTED BILL OF MATERIAL

ASSY NUMBER 857H0009

CTR 14 DC,FINAL ASM

REV

DATE 07/13/99

PAGE: 2

TYPE	PART NUMBER	QTY	UOM	DESCRIPTION	NEXT ASSY	CIR 57H	CODE	BOX	K/N
. .	031A3500	1	EA	50PF S CAP	807C0081		1		K
. .	041A3102	5	EA	.001uf,50v CAP	807C0081		1		K
. .	041A3103	5	EA	CAP.01/63/5	807C0081		1		K
. .	041A3222	1	EA	CAP .0022/63/5	807C0081		1		K
. .	041A3223	1	EA	CAP.022/63/5	807C0081		1		K
. .	041A4104	4	EA	.1uf,63v F CAP	807C0081		1		K
. .	041A4153	3	KA	CAP .015/63/10	807C0081		1		K
. .	041A4474	2	EA	.47uf,63v F CAP	807C0081		1		K
. .	041A4563	4	EA	.056UF 63V F CAP	807C0081		1		K
. .	11022101	3	EA	100 1/4W 5% CF RES	807C0081		1		K
. .	11022103	17	EA	10K 1/4W 5% CF RES	807C0081		1		K
. .	11022104	13	EA	100K 1/4W 5% CF RES	807C0081		1		K
. .	11022105	5	EA	1M 1/4W 5% CF RES	807C0081		1		K
. .	11022122	1	EA	1.2K 1/4W 5% CF RES	807C0081		1		K
. .	11022153	9	EA	15K 1/4W 5% CF RES	807C0081		1		K
. .	11022154	2	EA	150K 1/4 5% CF RES	807C0081		1		K
. .	11022203	4	EA	20K 1/4W 5% CF RES	807C0081		1		K
. .	11022222	6	EA	2.2K 1/4W 5% CF RES	807C0081		1		K
. .	11022274	2	EA	270K 1/4W 5% CF RES	807C0081		1		K
. .	11022304	2	EA	300K 1/4W 5% CF RES	807C0081		1		K
. .	11022333	1	EA	33K 1/4W 5% CF RESISTOR	807C0081		1		K
. .	11022334	7	EA	330K 1/4W 5% CF RES	807C0081		1		K
. .	11022360	2	KA	RES 360HM 1/4W 5% CF	807C0081		1		K
. .	11022392	4	EA	3.9K 1/4W 5% CF RES	807C0081		1		K
. .	11022471	4	EA	470 1/4W 5% CF RES	807C0081		1		K
. .	11022472	2	EA	4.7K 1/4W 5% CF RESISTOR	807C0081		1		K
. .	11022473	2	EA	47K 1/4W 5% CF RES	807C0081		1		K
. .	11022474	1	EA	470K 1/4W 5% CF RES	807C0081		1		K
. .	11022621	1	EA	RES 620 OHM 1/4W 5% CF	807C0081		1		K
. .	11022662	3	EA	6.8K 1/4W 5% CF RES	807C0081		1		K
. .	11022683	2	EA	68K 1/4W 5% CF RES	807C0081		1		K
. .	11022752	2	EA	7.5K 1/4W 5% CF RES	807C0081		1		K
. .	11022753	1	EA	75K 1/4W 5% CF RES	807C0081		1		K
. .	1202010T	8	EA	10.2K 1/4W 1% MF RES	807C0081		1		K
. .	1202013P	1	EA	1.33K 1/4W 1% MF RES	807C0081		1		K
. .	1202013T	1	EA	RES 13.3K 1/4W 1% MF	807C0081		1		K
. .	1202015U	1	EA	15.6K 1/4W 1% MF RES	807C0081		1		K
. .	1202015Y	2	EA	RES 1584 1/4W 1W MF	807C0081		1		K
. .	1202020H	1	EA	2.00K 14W 1 MF RES	807C0081		1		K
. .	1202020S	1	EA	RES 20K 1/4W 1% MF	807C0081		1		K
. .	1202048S	1	EA	RES 48.7K 1/4W 1% MF	807C0081		1		K
. .	1202048W	1	EA	RES 487K 1/4W 1% MF	807C0081		1		K
. .	15H33103	9	EA	10K V TRIM	807C0081		1		K
. .	15H33202	5	EA	2K V TRIM	807C0081		1		K
. .	15H33502	1	EA	5K VERTICAL TRIM POT	807C0081		1		K
. .	14411103	2	EA	RES. NET.,10K-4	807C0081		1		K
. .	14411203	1	EA	RES. NET., 20K-4	807C0081		1		K
. .	200A0000	27	EA	1N4148 DIODE	807C0081		1		K
. .	210A0002	2	EA	MPS2222	807C0081		1		K
. .	220A0000	7	EA	TRANSISTOR P PBT P1066E	807C0081		1		K

FIDELIPAC CORPORATION - INDENTED BILL OF MATERIAL

ASSY NUMBER 857B0009

CTR 14 DC, FINAL ASH

REV

DATE 07/15/99

PAGE: 4

TYPE	PART NUMBER	QTY	UOM	DESCRIPTION	NEXT ASSY	CTR SYM	CODE	BOX	R/N
	. . 220A0002	1	EA	P4392 TRANSISTOR	807C0081		1		K
	. . 230A0000	2	EA	5532 DUAL OP-AMP IC	807C0081		1		K
	. . 230A0001	4	EA	5533 DUAL OP-AMP IC	807C0081		1		K
	. . 230A0008	2	EA	LF353 IC	807C0081		1		K
	. . 230A0010	3	EA	RC4558 IC	807C0081		1		K
	. . 231A0024	1	EA	4052 IC ***RCA ONLY***	807C0081		1		K
	. . 231A0026	1	EA	4066 IC (NOT RCA)	807C0081		1		K
	. . 231A0027	1	EA	4528 IC (NATIONAL ONLY)	807C0081		1		K
	. . 231A0028	1	EA	4081 IC	807C0081		1		K
	. . 231A0030	1	EA	4069 IC	807C0081		1		K
	. . 231A0034	1	EA	4613 IC (NATIONAL ONLY)	807C0081		1		K
	. . 300A0000	4	EA	INDUCTOR BALUN	807C0081		1		K
	. . 361A0005	1	EA	SWITCH, SLIDE DP3POS	807C0081		1		K
	. . 407B0080	1	EA	PCB, RECORD	807C0081		1		K
	. . 410A0001	7	EA	SOCKET DIP 8 PIN	807C0081		1		K
	. . 410A0002	6	EA	SOCKET DIP 14 PIN	807C0081		1		K
	. . 410A0003	2	EA	SOCKET DIP 16 PIN	807C0081		1		K
	. . 417A0000	1	EA	PLUG 9 PIN D RT ANGLE	807C0081		1		K
	. . 41GA0001	1	EA	CONNECTOR HARDWARE	807C0081		1		K
	. . 420A0001	0	EA	WIRE BUS 22 AWG	807C0081		1		K
	. . 5ABA0007	2	EA	BOARD EJECTOR	807C0081		1		K
	. . 60120440	2	EA	NUT HEX 4-40 STEEL PLATE	807C0081		1		K
	. . 60C11400	2	EA	L WASHER I.T. #4	807C0081		1		K
	. . 62105440	2	EA	SCREW PH PHIL 4-40X5/16	807C0081		1		K
	. . 807E0076	1	EA	PLAY/CUB/LOGIC PWA	847B0009		1		K
	. . 006A8105	12	EA	PANASONIC 4300a-ND	807E0076	CK	1		K
						C37	C38	C39	C40
						C59			
	. . 011A5105	12	EA	10F 50V E CAP	807E0076	C1	1		K
						C2	C3	C4	C5
						C22	C28	C29	C34
						C45	C48	C50	
	. . 011A5106	7	EA	100F 50V E CAP	807E0076	C20	1		K
						C25	C31	C54	C55
						C56	C57		
	. . 011A5225	1	EA	2.20F 50V E CAP	807E0076	C23	1		K
	. . 011A5226	1	EA	220F 25V E CAP	807E0076	C35	1		K
	. . 011A5475	2	EA	4.7UF 50V E CAP	807E0076	C10	1		K
						C27			
	. . 011A5685	1	EA	6.8 UF 50V E CAP 20%	807E0076	C30	1		K
	. . 011A8107	5	EA	100UF 25V E CAP	807E0076	C36	1		K
						C42	C43	C44	C46
	. . 011B5536	3	EA	330F 25V E CAP	807E0076	C7	1		K
						C8			

*Play Due*

FIDELIPAC CORPORATION - INDENTED BILL OF MATERIAL

ASSY NUMBER 85780009

CTR 14 DC,FINAL ASH

REV

DATE 07/15/99

PAGE: 5

TYPE	PART NUMBER	QTY	UOM	DESCRIPTION	NEXT ASSY	CTR	SYM	CODE	BOX	K/N	
								C35			
	. . 031A3101	6	BA	100pf S CAP	80780076			C24	1	K	
								C26	C49	C51	C52
								C53			
	. . 041A3102	2	BA	.001uf,50v CAP	80780076			C13	1	K	
								C14			
	. . 041A3103	4	BA	CAP.01/63/5	80780076			C6	1	K	
								C9	C11	C12	
	. . 041A4104	3	BA	.1uf,63v F CAP	80780076			C21	1	K	
								C41			
								C58			
	. . 041A4472	3	BA	.0047UF 63V F CAP	80780076			C15	1	K	
								C16			
								C32			
	. . 041A4473	3	BA	.047uf, 63vF CAP	80780076			C17	1	K	
								C18			
								C19			
	. . 11022102	7	EA	1K 1/4W 5% CF RES	80780076			13	1	K	
								54	78	79	82
								63	R11		
	. . 11022103	7	EA	10K 1/4W 5% CF RES	80780076			21	1	K	
								39	42	59	66
								60	R14		
	. . 11022104	3	BA	100K 1/4W 5% CF RES	80780076			50	1	K	
								55			
								R49			
	. . 11022105	3	BA	1M 1/4W 5% CF RES	80780076			48	1	K	
								61			
								R47			
	. . 11022114	1	BA	RES,110K,1/4W,5%,CF	80780076			R12	1	K	
	. . 11022121	2	BA	RES,120 OHM,1/4W,5%,CF	80780076			73	1	K	
								R69			
	. . 11022152	3	BA	1.5K 1/4W 5% CF RES	80780076			34	1	K	
								62			
								R28			
	. . 11022154	4	BA	150K 1/4 5% CF RES	80780076			35	1	K	
								60	71	75	
	. . 11022164	1	BA	RES 160K, 1/4W, 5%, CF	80780076			R10	1	K	

FIDELIPAC CORPORATION - INDENTED BILL OF MATERIAL

ASSY NUMBER 857B0009

CYR 14 DC,FINAL ASH

REV

DATE 07/13/99

PAGE: 6

TYPE	PART NUMBER	QTY	UOM	DESCRIPTION	NEXT ASSY	CIR SYM	CODE	BOX	K/N
.	11022204	1	EA	RES 200K 1/4W 5% CF	807E0076	R25	1		K
.	11022221	4	EA	220 1/4W 5% CF RES	807E0076	18	1		K
						-----			
						44	64	65	
						-----			
.	11022222	5	EA	2.2K 1/4W 5% CF RES	807E0076	15	1		K
						-----			
						16	36	40	84
						-----			
.	11022224	1	EA	220K, 1/4W 5%	807E0076	R31	1		K
.	11022273	1	EA	27K 1/4W 5% CF RES	807E0076	R32	1		K
.	11022331	1	EA	3300HM 1/4W 5% RESISTOR	807E0076	R30	1		K
.	11022332	3	EA	3.3K 1/4W 5% CF RES	807E0076	53	1		K
						56			
						72			
.	11022333	2	EA	33K 1/4W 5% CF RESISTOR	807E0076	67	1		K
						68			
.	11022334	1	EA	330K 1/4W 5% CF RES	807E0076	R58	1		K
.	11022391	1	EA	330 1/4W 5% CF RES	807E0076	R58	1		K
.	11022392	2	EA	3.9K 1/4W 5% CF RES	807E0076	26	1		K
						81			
.	11022393	2	EA	RES 39K 1/4W 5% CF	807E0076	37	1		K
						41			
.	11022473	2	EA	47K 1/4W 5% CF RES	807E0076	63	1		K
						76			
.	11022682	2	EA	6.8K 1/4W 5% CF RES	807E0076	24	1		K
						77			
.	11022753	2	EA	75K 1/4W 5% CF RES	807E0076	70	1		K
						74			
.	11022821	2	EA	820 1/4W 5% CF RES	807E0076	23	1		K
						57			
.	11032101	2	EA	100 1/2W 5% CF RES	807E0076	51	1		K
						52			
.	1202010S	4	EA	10K,1/4W 1% RESISTOR	807E0076	17	2		K
						-----			
						19	43	45	
						-----			
.	1202051H	2	EA	5.11K 1/4W 1% HF RES	807E0076	20	1		K



FIDELIFAC CORPORATION - INDENTED BILL OF MATERIAL

ASSY NUMBER 857B0009

CTR 14 DC,FINAL ASM

REV

DATE 07/13/99

PAGE: 7

TYPE	PART NUMBER	QTY	UOM	DESCRIPTION	NEXT ASSY	CIR	STM	CODE	BOX	R/N	
								46			
	. . 13M33103	2	EA	10K V TRIM	807B0076			4	1	K	
								5			
	. . 13M33202	3	EA	2K V TRIM	807B0076			R1	1	K	
								R2			
								R3			
	. . 13M33203	2	EA	20K V TRIM	807B0076			R7	1	K	
								R9			
	. . 13M33504	2	EA	500K V TRIM	807B0076			R6	1	K	
								R8			
	. . 13T33202	3	EA	2K H IT TRIM	807B0076			R22	1	K	
								R29			
								R33			
	. . 13T33502	1	EA	5K H TRIM	807B0076			R27	1	K	
	. . 14411103	2	EA	RES. NET., 10K-4	807B0076			RN2	1	K	
								RN9			
	. . 14411104	2	EA	RES. NET. 100K-4	807B0076			RN4	1	K	
								RN5			
	. . 14411105	1	EA	RES. NET., 1M-4	807B0076			RN8	1	K	
	. . 14411392	2	EA	RES NET 3.9K-4	807B0076			RN6	1	K	
								RN7			
	. . 14411474	1	EA	RES. NET., 470K-4	807B0076			RN3	1	K	
	. . 19611103	1	RA	RESISTOR NETWORK 10K-9	807B0076			RN1	1	K	
	. . 200A0000	34	EA	1N4148 DIODE	807B0076			D1	1	K	
								D2	D3	D4	D5
								D6	D7	D8	D9
								D10	D11	D12	D14
								D15	D16	D17	D18
								D19	D20	D21	D22
								D23	D24	D25	D26
								D27	D28	D30	D31
								D32	D35	D36	D37
								D38			
	. . 201A0000	2	EA	1N4005 DIODE	807B0076			D33	1	K	
								D34			
	. . 204A0005	1	EA	DIODE, ZENER, 27V,	807B0076			D13	1	K	

FIDELIPAC CORPORATION - INDENTED BILL OF MATERIAL

ASSY NUMBER 85780009

CTR 14 DC,FINAL ASH

REV

DATE 07/13/99

PAGE: 8

TYPE	PART NUMBER	QTY	UOM	DESCRIPTION	NEXT ASSY	CTR	SYM	CODE	BOX	K/N
.	. 210A0002	13	EA	MPS2222	80780076		Q1	1		K
							Q2	Q3	Q5	Q6
							Q8	Q9	Q10	Q11
							Q12	Q13	Q16	Q18
.	. 211A0002	1	EA	TRANSISTOR NPN TIP120	80780076		Q15	1		K
.	. 211A0004	1	EA	D4582 TRANSISTOR	80780076		Q14	1		K
.	. 220A0000	5	EA	TRANSISTOR P FBT P1086E	80780076		Q4	1		K
							Q7	Q17	Q19	Q20
.	. 230A0000	3	EA	5532 DUAL OP-AMP IC	80780076		U4	1		K
							U7			
							U13			
.	. 230A0003	1	EA	LM3900 IC	80780076		U8	1		K
.	. 230A0008	1	EA	LF353 IC	80780076		U12	1		K
.	. 230A0010	2	EA	RC4558 IC	80780076		U1	1		K
							U2			
.	. 231A0028	2	EA	4081 IC	80780076		U3	1		K
							U10			
.	. 231A0030	1	EA	4069 IC	80780076		U6	1		K
.	. 231A0033	1	EA	72C42 IC	80780076		U5	1		K
.	. 231A0044	1	EA	4044 IC	80780076		U9	1		K
.	. 300A0000	4	EA	INDUCTOR BALUN	80780076		C1	1		K
							C2	T1	T2	
.	. 350A0000	2	EA	RELAY SPDT 12V PC MOUNT	80780076		K1	1		K
							K2			
.	. 40780075	1	EA	PCB,PLAY/CUE/LOGIC	80780076			1		K
.	. 410A0001	6	EA	SOCKET DIP 8 PIN	80780076			1		K
.	. 410A0002	4	EA	SOCKET DIP 14 PIN	80780076			1		K
.	. 410A0003	2	EA	SOCKET DIP 16 PIN	80780076			1		K
.	. 416A0004	1	EA	RECEPTACLE 9 PIN D	80780076			1		K
.	. 416A0001	1	EA	CONNECTOR HARDWARE	80780076			1		K
.	. 420A0001	1	EA	WIRE BUS 22 AWG	80780076			1		K
.	. 423A255N	1	EA	WIRE STRANDED 26 AWG GRN	80780076			1		K
.	. 426A0001	6	EA	WIRE 2 COND W/SHIELD	80780076			1		K
.	. 445A0000	1	EA	TUBING HEAT SHRINK 3/16	80780076			1		K
.	. 5A6A0007	2	EA	BOARD BRACKET	80780076			1		K
.	. 60120440	2	EA	NUT HEX 4-40 STEEL PLATE	80780076			1		K

FIDELIPAC CORPORATION - INDENTED BILL OF MATERIAL

ASSY NUMBER 85780009

CTR 14 DC,FINAL ASM

REV

DATE 07/13/99

PAGE: 9

TYPE	PART NUMBER	QTY	UOM	DESCRIPTION	NEXT ASSY	CTR SYM	CODE	BOX	X/N
	. . 60C11400	2	EA	L WASHER I.T. #4	807E0076		1		K
	. . 62105440	2	EA	SCREW PH PHIL 4-40X5/16	807E0076		1		K
	. . 837A0022	1	EA	SHIELDED JUMPER ASM	807R0076		1		K
	. . 807G0105	1	EA	MOTHER BD ASM,CTR10 DC	847R0009		5		K
	. . 006A6103	6	EA	PANASONIC 4300a-ND	807G0105	C10	1		K
						C15	C16	C17	C18
						C19			
	. . 011A5686	3	EA	CAP 6800 UF 50V	807G0105	C1	1		K
						C2			
						C3			
	. . 011A6107	6	EA	100UF 25N E CAP	807G0105	C4	1		K
						C5	C6	C7	C8
						C9			
	. . 031A250A	1	EA	5pf CAPACITOR	807G0105	C11	1		K
	. . 031A3221	3	EA	220pf, S CAP	807G0105	C12	1		K
						C13			
						C14			
	. . 11022103	9	EA	10K 1/4W 5% CF RES	807G0105	R1	1		K
						R2	R3	R4	R9
						R11	R12	R13	R14
	. . 11022104	1	EA	100K 1/4W 5% CF RES	807G0105	R10	1		K
	. . 11022223	3	EA	22K 1/4W 5% CF RES	807G0105	R16	1		K
						R17			
						R18			
	. . 11022471	1	EA	470 1/4W 5% CF RES	807G0105	R6	1		K
	. . 11022472	1	EA	4.7K 1/4W 5% CF RESISTOR	807G0105	R7	1		K
	. . 11022473	1	EA	47K 1/4W 5% CF RES	807G0105	R5	1		K
	. . 11022474	1	EA	470K 1/4W 5% CF RES	807G0105	R	1		K
						R8			
	. . 14411392	1	EA	RES NET 3.9K-4	807G0105	R15	1		K
	. . 206A0000	1	EA	1N4148 DIODE	807G0105	D14	1		K
	. . 201A0000	5	EA	1N4005 DIODE	807G0105	D5	1		K
						D6	D11	D12	D13
	. . 201A0002	8	EA	6A4 DIODE	807G0105	D1	1		K
						D2	D3	D4	D7
						D8	D9	D10	
	. . 204A0002	2	EA	1N4733A DIODE	807G0105	CR1	1		K

*MoM Board*

FIDELIPAC CORPORATION - INDENTED BILL OF MATERIAL

ASSY NUMBER 857B0009

CTR 14 DC, FINAL ASN

REV

DATE 07/13/95

PAGE: 10

TYPE	PART NUMBER	QTY	UOM	DESCRIPTION	NEXT ASSY	CTR SYN	CODE	BOX	K/N	
							CR2			
.	210A0002	1	EA	MPS2222	807G0105	Q2	1		K	
.	210A0003	2	EA	2N4403 TRANSISTOR	807G0105	Q1	1		K	
							Q3			
.	230A0010	1	EA	RC4558 IC	807G0105	2	1		K	
.	230A0406	1	EA	IC, HC4053	807G0105	U8	1		K	
.	231A0023	1	EA	4040 IC	807G0105	I1	1		K	
							U1			
.	231A0403	1	EA	IC 74HC00	807G0105	U6	1		K	
.	231A0404	1	EA	IC 74HC4040	807G0105	U7	1		K	
.	231A0405	1	EA	IC 74HC4060	807G0105	U3	1		K	
.	231A0412	2	EA	IC 74HC163	807G0105	U4	1		K	
							U5			
.	250A0298	1	EA	LED, GREEN	807G0105	D15	1		K	
.	250A0299	1	EA	LED, RED	807G0105	D16	1		K	
.	3700003	1	EA	REGULATOR MC78M05CT	807G0105	VR5	5		K	
.	384A0000	1	EA	CRYSTAL 18.432MHZ HC18U	807G0105	Y1	1		K	
.	407G0105	1	EA	PCB, MOTHER HD CTR10 DC	807G0105	PCB	5		K	
.	410A0001	1	EA	SOCKET DIP 8 PIN	807G0105	SU2	1		K	
.	410A0002	1	EA	SOCKET DIP 14 PIN	807G0105	SU6	1		K	
.	410A0003	8	EA	SOCKET DIP 16 PIN	807G0105	J2	1		K	
							J1	SU1	SU3	SU4
							SU5	SU7	SU8	
.	410A0009	4	EA	SOCKET TRANSISTOR	807G0105	SVR1	1		K	
							SVR2	SVR3	SVR4	
.	412A0001	1	EA	CONN EDGE 28 POS DUAL	807G0105	J4	1		K	
							J5			
.	416A0006	1	EA	12 PIN NR HEADER	807G0105	P2	1		K	
.	416A0008	1	EA	HEADER MTA 100 2 POS	807G0105	P4	1		K	
.	416A0009	1	EA	HEADER MTA 100 3 POS	807G0105	P5	1		K	

ASSY NUMBER 857B0009

CTR 14 DC, FINAL ASN.

REV

DATE 07/13/99

PAGE: 11

TYPE	PART NUMBER	QTY	UOM	DESCRIPTION	NEXT ASSY	CIR SYM	CODE	BOX	K/N
	. . 416A0011	1	EA	HEADER MTA 100 6 POS	807G0105	P8	1		K
	. . 416A0012	1	EA	HEADER MTA 100 7 POS	807G0105	P5	1		K
	. . 416A0016	2	EA	HEADER .079 9 POS	807G0105	P6	1		K
						P7			
	. . 418A0003	1	EA	RECEPTACLE 50 PIN D	807G0105	J3	1		K
	. . 4700036	2	EA	TRANSISTOR MPS-8599	807G0105	Q4	5		K
						Q5			
	. . 525A0105	1	EA	SHIELD CTR10 MTR DD	807G0105		5		K
	. . 541A0050	1	EA	HEAT SINK , 10220 BU MT	807G0105	HS1	5		K
	. . 60120440	2	EA	NUT HEX 4-40 STEEL PLATE	807G0105	H8	1		K
						H9			
	. . 60120632	1	EA	NUT HEX 6-32 STEEL PLATE	807G0105	H3	1		K
	. . 60C11400	2	EA	L'WASHER I.T. #4	807G0105	H6	1		K
						H7			
	. . 60C11600	1	EA	L'WASHER I.T. #6	807G0105	H2	1		K
	. . 62104440	2	EA	SCREW,PH PAN 4-40x1/4 SP	807G0105	H4	1		K
						H5			
	. . 62104632	1	EA	SCREW PH PHIL 6-32x1/4 PL	807G0105	H1	1		K
	. 827A0020	1	EA	ASN,FRONT PANEL CTR14	847B0009		1		K
	. . 11022130	6	EA	13 1/4W 5% CF RES	827A0020		1		K
	. . 260A0001	6	EA	LAMP 382	827A0020		1		K
	. . 364A0005	6	EA	SWITCH PUSH BUTTON	827A0020		1		K
	. . 364A0006	3	EA	LENS - SWITCH WHITE	827A0020		1		K
	. . 364A0007	2	EA	LENS - SWITCH RED	827A0020		1		K
	. . 364A0008	1	EA	LENS - SWITCH GREEN	827A0020		1		K
	. . 407A0090	1	EA	PCB, SWITCH R/P	827A0020		1		K
	. . 410A0003	1	EA	SOCKET DIP 16 PIN	827A0020		1		K
	. . 532B0008	1	EA	FRONT PANEL CTR10	827A0020		1		K
	. . 581A0010	1	EA	OVERLAY, SWITCH RP	827A0020		1		K
	. . 582A0006	4	EA	SPACER HEX 1/4 X 7/8	827A0020		1		K
	. . 60C11600	4	EA	L'WASHER I.T. #6	827A0020		1		K
	. . 62104632	4	EA	SCREW PH PHIL 6-32x1/4 PL	827A0020		1		K
	. . 64504632	4	EA	SCREW,PH FL 6-32x1/4 SP	827A0020		1		K
	. . 807A0101	1	EA	VU PWA, CTR14	827A0020		1		K
	. . . 011A5106	2	EA	100UF 50V E CAP	807A0101		1		K
	. . . 011A8107	1	EA	100UF 25N E CAP	807A0101		1		K
	. . . 11022103	4	EA	10K 1/4W 5% CF RES	807A0101		1		K
	. . . 11022122	2	EA	1.2K 1/4W 5% CF RES	807A0101		1		K

*Part Panel*

*VU Meter*

FIDELIPAC CORPORATION - INDENTED BILL OF MATERIAL

ASSY NUMBER 857B0009

CTR 14 DC, FINAL ASH

REV

DATE 07/15/93

PAGE: 12

TYPE	PART NUMBER	QTY	UOM	DESCRIPTION	NEXT ASSY	CIR SYN	CODE	BOX	K/R
	. . . 11022752	2	EA	7.5K 1/4W 5% CF RES	807A0101		1		K
	. . . 11052681	2	EA	660 1/2 5% CF RES	807A0101		1		K
	. . . 13733202	2	EA	2K H IT TRIM	807A0101		1		K
	. . . 15082500	2	EA	50 5W 5% WW RES	807A0101		1		K
	. . . 210A0003	2	EA	2N4403 TRANSISTOR	807A0101		1		K
	. . . 236A0002	2	EA	LM3916N IC	807A0101		1		K
	. . . 250A0003	1	EA	LED RED	807A0101		1		K
	. . . 250A0004	1	EA	LED GREEN	807A0101		1		K
	. . . 40700100	1	EA	PCB, CTR14 VU	807A0101				R
	. . . 410A0003	1	EA	SOCKET DIP 16 PIN	807A0101		1		K
	. . . 410A0007	2	EA	SOCKET DIP 18 PIN	807A0101		1		K
	. . . 416A0011	1	EA	HEADER MTA 100 6 POS	807A0101		1		K
	. . . 5B2A0022	4	EA	SPACER-HEX 3/16X5/8X2-56	807A0101		1		K
	. . . 60CJ1200	8	EA	L WASHER I.T. #2	807A0101		1		K
	. . . 62104256	8	EA	SCREW PH PHIL 2-56X1/4 SP	807A0101		1		K
A	. . . 807A0299	2	EA	BARGRAPH PWA	807A0101		1		K
	. . . . 11022820	3	EA	62 OHM Y&W 5% CF RES	807A0299		1		K
	. . . . 250A0298	7	EA	LED, GREEN	807A0299		1		K
	. . . . 250A0299	5	EA	LED, RED	807A0299		1		K
	. . . . 407A0299	1	EA	BARGRAPH PCB	807A0299		1		K
	. . . . 425A0000	1	EA	DIP JUMPER 12 POS 2 INCH	807A0299		1		K
A	827A0021	1	EA	ASM, HEAT SINK CTR10	847B0009		1		K
	. . 230A0012	2	EA	LM7815CT +15V REGULATOR	827A0021		1		K
	. . 230A0014	1	EA	LM7815CT-15V REGULATOR	827A0021		1		K
	. . 230A0015	1	EA	IC, AN7918, 18V REG	827A0021		1		K
	. . 440A0000	4	EA	INSULATOR TO 220 SIL PAD	827A0021		1		K
	. . 541B0033	1	EA	HEAT SINK, MOTHER BD,	827A0021		1		K
	. . 60701124	4	EA	WASHER SHOULDER	827A0021		1		K
	. . 62103440	4	EA	SCREW, PH 4-40 x 3/16 PL	827A0021		1		K
	. 827A0026	1	EA	ASM DECK CTR10	847B0009		1		K
	. . 320A0000	1	EA	SOLENOID	827A0026		1		K
	. . 415A0011	1	EA	HOUSING MTA 100 2 COND	827A0026		1		K
	. . 526A0000	1	EA	STUD SOLENOID	827A0026		1		K
	. . 531B0002	1	EA	DECK PLATE CTR10 100A ESD	827A0026		1		K
	. . 543B0011	1	EA	STOP ACTUATOR	827A0026		1		K
	. . 543D0008	1	EA	ACTUATOR CART	827A0026		1		K
	. . 5A6A0000	1	EA	CHAIN SPROCKET .1475	827A0026		1		K
	. . 5A1A0001	1	EA	FOOT	827A0026		1		K
	. . 5A3A0000	4	EA	ROLLER CART HOLD DOWN	827A0026		1		K
	. . 5AAB0002	1	EA	SPROCKET SOLENOID	827A0026		1		K
	. . 5ABB0003	2	EA	BRARING HOLD DOWN SHAFT	827A0026		1		K
	. . 5B3A0001	4	EA	RETAINER RING 3/16 SHAFT	827A0026		1		K
	. . 5B4A0000	1	EA	HEADL SPIRAL PIN	827A0026		1		K
	. . 5B6A0003	1	EA	SHAFT CART HOLD DOWN	827A0026		1		K
	. . 5B8B0001	1	EA	SHAFT VERT BALL BEARING	827A0026		1		K
	. . 5B8E0002	1	EA	SHAFT HORIZONTAL	827A0026		1		K
	. . 5B1A0002	1	EA	SPRING EXTENSION SOLENOID	827A0026		1		K
	. . 5B1B0001	1	EA	SPRING EXTENSION SWITCH	827A0026		1		K
	. . 5R2A0002	1	EA	SPRING, CART HOLD DOWN	827A0026		1		K
	. . 60020052	1	EA	NUT HEX 10-32 STL PL	827A0026		1		K

*Sub*

*Don*

ASSY NUMBER 857B0009

CTR 14 DC, FINAL ASM

REV

DATE 07/13/95

PAGE: 13

TYPE	PART NUMBER	QTY	UOM	DESCRIPTION	NEXT ASSY	CTR SYM	CODE	BOX	K/N
	. . . 60107000	4	EA	WASHER .31X.191X.025 SS	827A0026		1		K
	. . . 60107001	1	EA	WASHER .53X.15X.05 SS	827A0026		1		K
	. . . 60107002	2	EA	WASHER .50X.252X.01 SS	827A0026		1		K
	. . . 60C11600	3	EA	L'WASHER I.T. #10	827A0026		1		K
	. . . 60C11200	1	EA	L'WASHER I.T. #2	827A0026		1		K
	. . . 60C11600	3	EA	L'WASHER I.T. #6	827A0026		1		K
	. . . 62103256	1	EA	SCREW PH PHIL 2-56X3/16ZP	827A0026		1		K
	. . . 62103440	1	EA	SCREW,PH 4-40 x 3/16 PL	827A0026		1		K
	. . . 62104440	2	EA	SCREW,PH PAN 4-40x1/4 SP	827A0026		1		K
	. . . 62105440	1	EA	SCREW PH PHIL 4-40X5/16	827A0026		1		K
	. . . 62105632	2	EA	SCREW PH PHIL 6-32X5/16PL	827A0026		1		K
	. . . 62106632	1	EA	SCREW PH PHIL 6-32X3/8 ZP	827A0026		1		K
	. . . 62108032	2	EA	SCREW PH PHIL 10-32X.5 SP	827A0026		1		K
	. . . 700A0001	1	EA	GLUE BASTMAN 910 OR EQUIV	827A0026		1		K
A	. . . 827A0025	1	EA	RIGHT BRACKET ASM CTR10	827A0026		1		K
	. . . 543R0007	1	EA	BRKT CART HOLD DOWN RIGHT	827A0025		1		K
	. . . 5ABD0003	2	EA	BRARING HOLD DOWN SHAFT	827A0025		1		K
	. . . 5B2A0010	1	EA	SPACER 1/4X3/8 #4 NYLON	827A0025		1		K
	. . . 5B2A0011	1	EA	SPACER 1/4X1/2 RED NYL #4	827A0025		1		K
	. . . 5B2A0002	1	EA	SPRING, CART HOLD DOWN	827A0025		1		K
	. . . 68703440	2	EA	SCREW RD S; 4-40X3/16 NYL	827A0025		1		K
	. . . 68708440	3	EA	SCREW RD SL 4-40X3/16 NYLN	827A0025		1		K
A	. . . 807A0061	1	EA	CART READY PWA,CTR10	827A0025		1		K
	. . . . 11032681	1	EA	680 1/2 5% CF RES	807A0061		1		K
	. . . . 271A0001	1	EA	OP550 PHOTO TRANSISTOR	807A0061		1		K
	. . . . 271A0002	1	EA	IR EMITTING DIODE	807A0061		1		K
	. . . . 351A0000	1	EA	SWITCH,SLIDE,SPDT	807A0061		1		K
	. . . . 407B0060	1	EA	CART SCAN PCB	807A0061		1		K
	. . . . 416A0019	1	EA	HEADER, 3 POS RT	807A0061		1		K
	. . . . 420A0001	0	EA	WIRE BUS 22 AWG	807A0061		1		K
A	. . . 827A0063	1	EA	LEFT BRKT ASM "A"	827A0026		1		K
	. . . 543F0009	1	EA	BRKT CART HOLD DN LEFT A	827A0063		1		K
	. . . 5B5A0000	1	EA	RIVBT	827A0063		1		K
	. . . 5E2B0001	1	EA	SPRING CART GUIDE	827A0063		1		K
	. . . 827A0065	1	EA	ACTUATOR "A" REAR SHAFT	827A0026		1		K
A	. . . 827A0404	1	EA	TRANSFORMER ASM, TORROID	847B0009		5		K
	. . . 311B0404	1	EA	TRANSFORMER, TORROID	827A0404		5		K
	. . . 414A0007	7	EA	TERMINAL, MR	827A0404	JP2	1		K
	. . . 414A0014	3	EA	TERMINAL,H 1PSN 18-26GA	827A0404	JP1	5		K
	. . . 415A0015	1	EA	HOUSING, 12 PIN MR	827A0404	J2	1		K
	. . . 415A0020	1	EA	CONN. 4 PIN	827A0404	J1	5		K
	. . . 423A189H	0	EA	WIRE STRANDED 18GA WHITE	827A0404		5		K
A	. . . 827B0024	1	EA	ASM, REAR PANEL, CTR10	847B0009		1		K
	. . . 360A0001	1	EA	SWITCH TOGGLE	827B0024		1		K
	. . . 371A0001	1	EA	FUSE 1A SLO BLO	827B0024		1		K
	. . . 413A0000	1	EA	CONNECTOR AC 3 PIN RECEPT	827B0024		1		K

*XFR*

*Rear*

FIDELIPAC CORPORATION - INDENTED BILL OF MATERIAL

ASSY NUMBER 85780009

CTR 14 DC, FINAL ASH

REV

DATE 07/13/93

PAGE: 14

TYPE	PART NUMBER	QTY	UOM	DESCRIPTION	NEXT ASSY	CIR SYM	CODE	BOX	K/N
	. . 414A0067	3	EA	TERMINAL, NR	82780024		1		K
	. . 415A0014	1	EA	HOUSING, 4 PIN NR	82780024		1		K
	. . 417A0004	1	EA	HOLE PLUG	82780024		1		K
	. . 423A220N	20	IN	WIRE STRANDED 22 AWG BLK	82780024		1		K
	. . 423A225N	16	IN	WIRE STRANDED 22 AWG GRN	82780024		1		K
	. . 423A229N	12	IN	WIRE STRANDED 22 AWG WHT	82780024		5		K
	. . 430A0000	1	EA	FUSE HOLDER PANEL MOUNT	82780024		1		K
	. . 445A0000	2	EA	TUBING HEAT SHRINK 3/16	82780024		1		K
	. . 445A0001	1	EA	TUBING HEAT SHRINK 1/8	82780024		1		K
	. . 445A0002	1	EA	TUBING HEAT SHRINK 3/4	82780024		1		K
	. . 54180035	1	EA	REAR PANEL, CTR10	82780024		1		K
	. . 5A2A0000	3	EA	TY WRAP 1/16 TO 2" DIA	82780024		1		K
	. . 5A2A0006	1	EA	GROUND LUG	82780024		1		K
	. . 5A4A0001	2	EA	CARD GUIDE #250 BIVAR	82780024		1		K
	. . 60033632	1	EA	NUT TRUMB 6-32	82780024		1		K
	. . 60120632	3	EA	NUT HEX 6-32 STEEL PLATE	82780024		1		K
	. . 60C11600	2	EA	WASHER L.T. #6	82780024		1		K
	. . 62103632	2	EA	SCREW PH PHIL 6-32X3/16PL	82780024		1		K
	. . 62106632	2	EA	SCREW PH PHIL 6-32X3/8 ZP	82780024		1		K
	. . 62106632	1	EA	SCREW PH PHIL 6-32X1/2 LG	82780024		1		K
	<i>Motor</i> A . 827C0409	1	EA	MOTOR ASM, CTR DC	84780009		5		K
	. . 323C0450	1	EA	DC MOTOR, CLIFTON	827C0409		5		K
	A . . 807F0420	1	EA	TACH ASSY	827C0409		1		K
	. . . 11022332	1	EA	3.3K 1/4W 5% CF RES	807F0420		1		K
	. . . 2010001	4	EA	STANDOFF PBM KFB440-8	807F0420		5		K
	. . . 272A0402	1	EA	OPTO SENSOR, SPH 906-2	807F0420		1		K
	. . . 3910022	1	EA	RES NF 150 OHM 1/4W 1%	807F0420		5		K
	. . . 407E0420	1	EA	TACH PCB, CTR90/100	807F0420		5		K
	. . . 414A0013	3	EA	CONNECTOR, BUTT SPLICE	807F0420		1		K
	. . . 423A221N	1	EA	WIRE 22 AWG BRN	807F0420		1		K
	. . . 423A222N	1	IN	WIRE STRANDED 22 AWG RED	807F0420		1		K
	. . . 423A223N	1	EA	WIRE STRANDED 22 AWG GRN	807F0420		1		K
	. . . 5A8A0000	1	EA	GROMMET RUBBER	807F0420		1		K
	. . . 5E2A0402	4	EA	SPRING, PENETRATION	807F0420		1		K
	. . . 62103440	4	EA	SCREW,PH 4-40 x 3/16 PL	807F0420		1		K
	A . 827F0401	1	EA	HEAD BRIDGE ASSY, PLASTIC	84780009		5		K
	. . 50180402	2	EA	HEAD LOCKING BLOCK	827F0401		1		K
	. . 501E0400	2	EA	BEARING BLOCK, PLASTIC	827F0401		5		K
	. . 502C0400	2	EA	HEAD SHAFT CTR90	827F0401		5		K
	A . . 512F0400	1	EA	HEAD BRIDGE FINISHED	827F0401		5		K
	. . . 512F1400	1	EA	HEAD BRIDGE (PLATED)	512F0400		5		N
	. . . 512F2400	1	EA	HEAD BRIDGE (PLASTIC)	512F0400		5		N
	. . 57080400	2	EA	HEIGHT ZENITH BEAM	827F0401		1		K
	. . 57080402	2	EA	THRUST PLATE, CTR90	827F0401		1		K
	. . 570C0401	2	EA	HEAD CLAMP, CTR 90	827F0401		1		K
	. . 571B0405	2	EA	AZIMUTH BEAM	827F0401		1		K
	. . 5ABA0001	1	EA	TAPE GUIDE CURVED	827F0401		1		K
	. . 5ABA0002	1	EA	TAPE GUIDE STRAIGHT	827F0401		1		K
	. . 5B6A0400	2	EA	BALL 3/16	827F0401		1		K
	. . 5E204148	2	EA	SPRING COMP .1486 X 1/4	827F0401		1		K

*Motor*

*Head Bridge*



ASSY NUMBER 857B0009

CTR 14 UC, FINAL ASM

REV

DATE 07/13/89

PAGE: 13

TYPE	PART NUMBER	QTY	UOM	DESCRIPTION	NEXT ASSY	CTR SYM	CODE	BOX	K/R
	. . 5E2A0400	4	EA	SPRING, ZENITH BEAM	827F0401		1		K
	. . 5E2A0401	2	EA	SPRING, AZIMUTH	827F0401		1		K
	. . 5E2A0402	2	EA	SPRING, PENETRATION	827F0401		1		K
	. . 80100400	4	EA	#4 FLAT WASHER STL PLATE	827F0401		1		K
	. . 60500231	2	EA	FLAT WASHER SS .187 OD	827F0401		1		K
	. . 645A0440	4	EA	SCREW FL PHIL 4-40X1/4 SS	827F0401		1		K
	. . 68208540	4	EA	SCRW 5-40X1/2 82 PH SOC	827F0401		1		K
	. . 68106440	4	EA	SCRW 4-40X3/8 PH STL	827F0401		1		K
	. . 6G204832	2	EA	SCRW SET 8-32X1/4 FLT TIP	827F0401		1		K
	. . 6G206832	2	EA	SCRW SET 8-32X3/8 FLT TIP	827F0401		1		K
	. . 6Y20A256	4	EA	SCRW SOC HC 2-56X5/8 BLK	827F0401		1		K
	. . 6Y210256	4	EA	SCRW SOC HC 2-56 X 1 BLK	827F0401		1		K
	. . 837A0011	1	EA	ASM READY CABLE CTR10	847B0009		1		K
	. . 415A0000	2	EA	CONNECTOR 3 TERMINAL MTA	837A0011		1		K
	. . 423A229N	36	IN	WIRE STRANDED 22 AWG WHT	837A0011		5		K
	. . 5A2A0000	4	EA	TY WRAP 1/16 TO 2" DIA	837A0011		1		K
	. . 837B0004	2	EA	HEAD CABLE S	847B0009		1		K
	. . 414A0006	9	EA	TERMINAL FOR .079 HOUSING	837B0004		1		K
	. . 416A0010	1	EA	HOUSING .079 9 POSITION	837B0004		1		K
	. . 837A0021	3	EA	HD CBL BASIC	837B0004		1		K
	. . 414A0010	2	EA	TERMINAL	837A0021		1		K
	. . 426A0001	10	EA	WIRE 2 COND W/SHIELD	837A0021		1		K
	. . 44SA0000	2	EA	TUBING HEAT SHRINK 3/16	837A0021		1		K
	. . 44SA0001	2	EA	TUBING HEAT SHRINK 1/8	837A0021		1		K
	. . 837B0006	1	EA	RECORD CABLE S	847B0009		1		K
	. . 415A0003	2	EA	HOUSING MTA 100 6 COND	837B0006		1		K
	. . 426A0000	0	EA	WIRE 2 COND W/SHIELD 8451	837B0006		1		K
	. . 44SA0000	0	EA	TUBING HEAT SHRINK 3/16	837B0006		1		K
	. . 44TA0002	0	EA	TUBING TEFロン 16 AWG	837B0006		1		K
	. . 5A2A0000	5	EA	TY WRAP 1/16 TO 2" DIA	837B0006		1		K
	. . 837D0010	1	EA	SERVO CABLE	847B0009		1		K
	. . 415A0013	2	EA	HOUSING 9 COND	837D0010		1		K
	. . 417A0000	4	EA	KEY - CONNECTOR	837D0010		1		K
	. . 423A229N	84	IN	WIRE STRANDED 22 AWG WHT	837D0010		5		K
	. . 5A2A0000	3	EA	TY WRAP 1/16 TO 2" DIA	837D0010		1		K
	. . PRK-2	1	EA	PINCH ROLLER KIT	847B0009		5		K
	. . 5A3C0002	1	EA	PINCH ROLLER	PRK-2		1		K
	. . 5B1A0003	1	EA	BALL BEARING	PRK-2		1		K
	. . 5B3A0001	1	EA	RETAINER RING 3/16 SHAFT	PRK-2		1		K
	. . 60107065	2	EA	WASHR SS .310DX191DX.065	PRK-2		1		K
	. . 60302124	2	EA	WAVY WASHER	PRK-2		1		K

Ready cable

Lead cable

Head cable

Rec only

Servo cable

PRK-2

- Rec.

END OF JOB

Constuction notes:

1. Watch out that the crystal is not shorted to ground.
2. ensure R84 on the play card is properly attached to the back of the card.
3. Power supply mods:
  - a. Jumper on DC voltage
  - b. 22 Meg resister
4. Make sure the motor shield is installed.
5. The rec/play intercard shild needs to be installed.
6. The sensor on the tach board needs to be perfectly perpendicular.
7. Ty wrap the transformer leads so they look "neat."

## Motherboard:

Remember to do the two mods on the mother boards.

1. Add the power jumper between two traces
2. Add a 22 Meg res. Look at the sample motherboard on the unit we built up and you will see what I am talking about.

## Motherboard LED's

One is for FF  
the other is for Cart ready,

when the cart is inserted and motor starts, front panel lights come on and such.

## Mechanical notes on CTR10

As for the solenoid.

You may find the bracket not at a perfect 90 Deg. Feel free to grab the solenoid and bend it up or down as needed. Whatever allows the solenoid shaft to travel freely.

---

Technically the PRK-1 can be used on any of our machines. The only difference is that the material is harder, therefore more sensitive to "splices".

The PRK-2 rollers last longer.