

The General Radio Experimenter

VOL. IV, No. 7

DECEMBER, 1929

TELEVISION: A COMPARISON WITH OTHER KINDS OF ELECTRICAL COMMUNICATION

By J. W. HORTON

TODAY, through the universal use of systems of electrical transmission, information may be conveyed in a negligible time between individuals separated by a distance restricted only by the dimensions of the earth. It is difficult for us to realize that until the time of Morse and his electric telegraph the instantaneous transfer of intelligence was confined within the limits of human vision. The potentialities arising from our ability to control an electric current at one place, to transmit it to some distant place, and to recognize there the effects of the initial control cannot be evaluated.

The fundamental principle underlying the telegraph, the telephone, picture transmission systems, and television is this: Complex electric waves, controlled at the sending station by the sound or image being sent, are used at the receiving station to actuate devices which reproduce the sound or the image. In television one does not see the person at the other end of the line, nor in telephony does one hear his voice. In one, the distant person is represented by an image reproduced by an optical system; in the other, his voice is represented by sounds reproduced by an acoustical system. The only thing ever transmitted is an electric wave.

The first step in the development of the art of electrical communication was taken thousands of years ago when man first devised symbols to represent ideas. These symbols were not adapted to electrical transmission. It was necessary, therefore, for Morse, in order to utilize his electric telegraph equipment, to modify the system of symbols (our alphabet) so that they were readily identified with the characteristics of an electric wave.

This brings us at once to an important fact: The distinguishing characteristic of an information-conveying electrical wave is the variation in its intensity with time. To be more specific, the intensity is a single-valued function of time; that is to say, it varies from instant to instant, and for any given instant there is one and only one corresponding value of intensity. In order to conform to this requirement of the electrical signal wave, the Morse code is likewise a single-valued function of time.

The information contained in the sounds we hear may also be completely represented in terms of a quantity which has different values for different times. Specifically, a sound may be described in terms of the variation in air pressure with time. To obtain the

[1]



IET LABS, INC in the GenRad tradition
534 Main Street, Westbury, NY 11590

TEL: (516) 334-5959 • (800) 899-8438 • FAX: (516) 334-5988

www.ietlabs.com

telephone, therefore, it was only necessary to provide terminal apparatus capable of following these exceedingly complex variations with sufficient accuracy and a channel capable of transmitting the corresponding electric wave.

When we attempt to extend electrical-communication methods to include visual information, we find that we have to deal with anything but a single-valued function of time. In a still picture the information may be described as a function of area only. This fundamental fact was recognized early in the history of electrical communication, and means have been devised for translating pictures into terms of a time variable. By means of scanning and distributing devices, information regarding the tone value of each elementary area of a picture may be transmitted individually over a single channel, the several areas being successively dealt with in a predetermined order and at a definite rate.

It is further necessary to provide for recording this information in order that the time factor may be eliminated and the information restored to its original form as a function of area only. In still-picture transmission, photographic methods are employed for making a permanent record. The result is a single picture, differing but little in appearance from an ordinary photograph. In television the record is made, not on a photographically-sensitive surface, but on the retina of the eye. It is necessary, therefore, to complete the transmission of a single image in a time so short that it is retained by the retina as a complete picture. Furthermore, in order to convey information as to any motion which may take place in the original object, it is necessary that a series of images be reproduced in rapid succession. Experience has shown that the transmission of approximately twenty

images per second satisfies both of these conditions.

When our eyes bring us information as a result of visual observations it is conveyed from the retina to the brain by a very considerable number of nerves, each carrying a separate message. In comparison with the speed with which an electric current may change its intensity, these nerves, in spite of their reputation to the contrary, are extremely sluggish. If we work our electrical system at the speed required for television it will convey in succession the messages representing the several picture elements, and it will distribute them to their respective nerve channels as rapidly as the nerves are capable of receiving them. In this respect television and the multiplex telegraph are amazingly alike. In both, one trunk circuit brings in information as fast as several local circuits, working simultaneously, can absorb it.

These considerations emphasize the fact that the *rate* at which information is transmitted is of very great significance in electrical communication. Inasmuch as it has been necessary, in order to effect their transmission, to reduce various forms of information to common terms, namely, those of time variation, we have at once a convenient basis for comparing them. It is desirable to do this in order to form an estimate of the relative magnitudes of the burdens imposed on the channel when it is used to transmit information in one form or another.

In the case of a single picture, it is apparent that the total amount of information is proportional to the number of individual elementary areas recognized. For example, if a picture of some given scene is printed from a halftone photo-engraving, the amount of information conveyed by the reproduction depends upon the total number of "halftone dots" used and not on the area of the picture. A fine magazine



halftone may easily include more information in an area one inch square than a coarse newsprint illustration in an area two inches square.

If the elementary areas of a picture as it is scanned for transmission alternate between dark and light, the number of cyclic variations of light intensity will be half the number of picture elements. The maximum frequency in the electric signal wave will, in turn, be equal to the maximum number of cyclic variations in the picture divided by the time required for its transmission. It is thus apparent that the greater the number of elementary areas separately recognized in a given time, the higher will be the maximum frequency required to transmit the image. It may be shown that the electric wave contains also a component of zero frequency.* Hence,

* J. W. Horton, "Transmission of Pictures and Images," *Proceedings of the I. R. E.*, September, 1929, p. 1547. This is an abstract of that paper.

the *frequency range* occupied by the signal is determined by (a) the number of picture elements and (b) by the time of transmission.

This is a special case of a fundamental law of communication, which states that the rate at which information may be transmitted over a given channel is proportional to the frequency range which that channel can accommodate. This concept is treated at some length in a paper presented at the Volta Centenary in Geneva by Mr. R. V. L. Hartley of the Bell Telephone Laboratories.† It may be employed in evaluating amounts of information by relating them to the product of the frequency range and the time of transmission.

To compare the amount of visible and audible information it will be necessary to make some assumptions

† R. V. L. Hartley, "Transmission of Information," *Bell System Technical Journal*, July, 1928, p. 535.

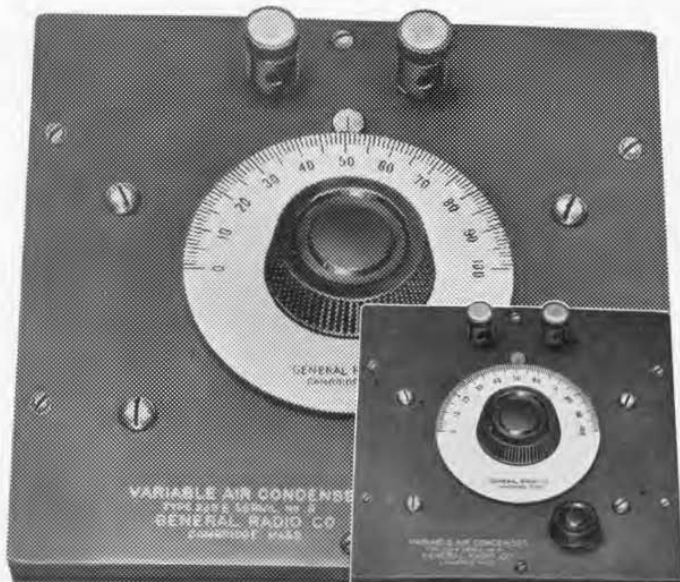

FIGURE 1. "A fine magazine halftone may contain more information in an area one inch square than a coarse newsprint illustration in an area two inches square." The small picture has approximately 55,000 dots, the large one, in spite of its increased size, has only 37,000

as to the degree of fidelity to be secured in the reproduction of each. Regardless of the detailed method by which the transmission of a single picture or image is effected, the reproduced copy will have a structure of some sort. In order for this to be negligible on normal inspection, as of ordinary photographs, it is essential to employ no less than 10,000 elementary areas for each square inch of picture surface.* This gives us a frequency range of 5000 cycles per square inch.

In the case of speech, it has been found that acceptable reproduction may be secured through a frequency range of less than 3500 cycles per second. This range is, of course, to a considerable extent independent of the rate at which the words are spoken. If we speak slowly, therefore, we are not utilizing the communication channel to its fullest advantage. To determine the normal relation between frequency range and the rate at which verbal information may be transmitted, let us imagine that a phonograph record is made of speech at the usual rate of about 100 words per minute. If this record is played back so that the words are reproduced at the rate of one per second, we find that the frequency range has been reduced to approximately 2000 cycles per second. Thus, one square inch of picture may be said to be roughly equivalent as an amount of information to 2.5 spoken words.

To obtain moderately satisfactory reproduction of a small picture, such as one 4 inches by 5 inches square, it is necessary to employ communication facilities — i.e., frequency range multiplied by the time they are used — equal in value to those required for 50 spoken words.

*The halftone engravings ordinarily used in the *Experimenter* have about 18,000 "dots" or elementary areas per square inch; in a newspaper, from 4200 to 7200 "dots" per square inch.

By means of further assumptions of a similar nature, we may arrive at the conclusion that the ratio of the amount of information received in a given time by our eyes, to that received by our ears, is somewhere in the neighborhood of 200 to 1. It must be emphasized that this merely indicates an order of magnitude, and that it depends entirely on some rather arbitrary assumptions. That the ratio is fairly high is evidenced by the fact that in the talking motion pictures, the sound-on-film record has required an almost negligible sacrifice in the space formerly allotted to the visual record alone.

These considerations are largely independent of the method used for reproducing the copy of the original picture or scene. It is to be expected that the attention now being directed to television will result in the development of entirely practicable means for effecting the required scanning operations, for controlling the electric current, and for reproducing the desired image at the receiving terminal. Such devices will not in themselves be the complete solution to the problem of television. It will also be necessary to provide communication channels having many times greater information-carrying capacity than those now generally available.

From this it follows that the future of television is largely a question of economics. We may recall in this connection that the biggest obstacle which Morse had to overcome before he could transmit a telegram to any distance was that of raising funds to build his line. In other words, it is the communication channel for which we pay when we employ electrical communication facilities. Let us not ignore the fact that the burden imposed on this channel by television is many times greater than that now borne in our existing electrical communications systems.



GAIN IN AMPLIFIERS AND OTHER NETWORKS

By ARTHUR E. THIESSEN

NEARLY everyone who has worked with transmission circuits has had at least a few occasions to use the much-abused terms, amplification and attenuation — or, simply, gain and loss — to identify the behavior of some particular circuit element such as an amplifier or an attenuation network. The purpose of the following is to define just what is meant by the familiar terms, gain and loss. Since loss is negative gain, by confining a discussion to gain alone the wording of definitions is simplified without in any way changing the meaning. Because the performance characteristics of most networks encountered in communication circuits are, for most practical purposes, the same when working between non-reactive and reactive circuits and because calculation and measurements are much simplified by so doing, we will consider all of the circuit elements to be non-reactive.

Gain always refers to the amount of power transferred across a junction from a generator or other power source to a load. In Figure 2a, a power source consisting of a source of voltage E_G in series with resistance R_G is shown connected directly to a load of resistance R_R . With a given source and load, there will always be a definite amount of power, determined by these constants, delivered across the junction $\mathcal{J}\mathcal{J}'$ and dissipated in the load. If the junction is opened and an amplifier put in, there will be an increase of power in the load. The ratio of the load power when the amplifier is in the circuit to the load power when the load is connected directly to the generator is called the "insertion gain" — or, sometimes, "transmission gain." The

power in the load when it is connected directly to the generator is called the reference power or reference condition. However, as we usually speak of gain, we mean a special case in which we take for the reference condition the case when all of the *available* generator power is transferred to the load. Thus, gain, as we ordinarily understand it, is the ratio of the load power when the amplifier is inserted at the junction to the load power when the load is so connected to the generator that it absorbs all of the *available* generator power. This is the condition for maximum power transfer across the junction,* which will be shown to occur when the load resistance equals the generator resistance.

In Figure 2a, let I_R be the current in the load R_R

$$I_R = \frac{E_G}{R_G + R_R},$$

and let W_R be the power in the load

$$W_R = I^2 R_R = \frac{E_G^2}{(R_G + R_R)^2} \cdot R_R.$$

Then differentiate W_R with respect to R_R to find the value of R_R for maximum W_R :

$$\frac{dW_R}{dR_R} = \frac{E_G^2}{(R_G + R_R)^2} - 2E_G^2 R_R (R_G + R_R)^{-3}$$

When W_R is a maximum, $\frac{dW_R}{dR_R} = 0$, and

$$\frac{E_G^2}{(R_G + R_R)^2} = \frac{2E_G^2 R_R}{(R_G + R_R)^3}$$

$$R_G + R_R = 2R_R \text{ and } R_R = R_G.$$

This means, of course, that in order to determine the reference condition for gain measurement, the load resistance

* See footnote, page 7.

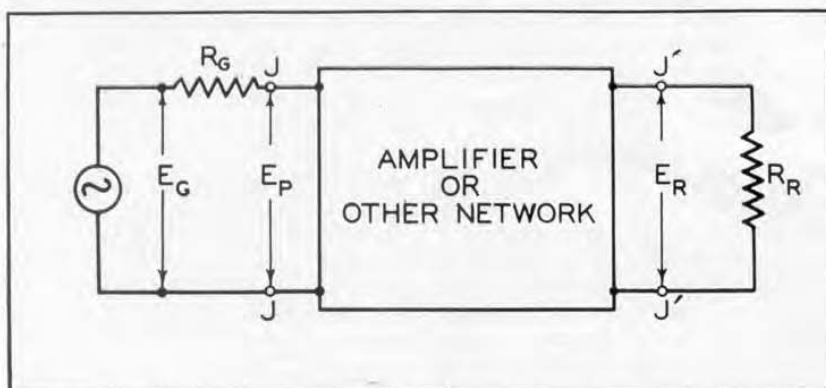

FIGURE 1. The gain resulting from inserting an amplifier or other network at the junction J' is the ratio between the resulting load power (power dissipated in R_R) and some *reference power* corresponding to a specified *reference condition*

must be equal to the generator resistance. If they are unequal, as is often the case, an impedance-matching device might be employed. An ideal device for this purpose is illustrated in Figure 2b. This is called an impedance-matching-transformer. It is one in which no power loss would occur and in which the apparent resistance of the primary is equal to the resistance of the generator when the secondary is connected to the load. Perfect matching would thus be obtained between the generator and the primary of the ideal transformer; therefore, all of the available generator power would be transferred across the junction from the generator to the transformer. Since there is no gain or loss of power in the ideal transformer, all of the power in its primary is delivered to the load. In other words, the ratio of the power output to the power input is unity in an ideal transformer. This is the reference condition that is used for the measurement of gain.

If we were to remove the theoretical ideal transformer and put the amplifier in its place, some increase of power in R_R should occur. The gain is the ratio of the load power realized with the am-

plifier in the circuit to the load power which would have existed at the reference condition. This is the same as saying that the gain of the amplifier is the ratio of its power output to the *available* power input.

This ratio is usually expressed in logarithmic units:* the gain in decibels N being equal to ten times the common logarithm of the power ratio:

$$N = 10 \log_{10} \frac{\text{Output Power}}{\text{Available Power}}$$

Since we can never actually have an ideal impedance-matching transformer, some means must be employed for determining the available power in order to fix the reference condition. Refer again to Figure 2b. The ideal transformer, by definition, has primary and secondary impedances which match R_G and R_R , respectively.

Then $E_P = \frac{1}{2} E_G$, and the power available at the input to the ideal transformer is

$$\frac{E_P^2}{R_G} = \frac{E_G^2}{4 R_G}$$

* J. W. Horton, "Units of Electrical Transmission," *General Radio Experimenter*, III, January, 1929.

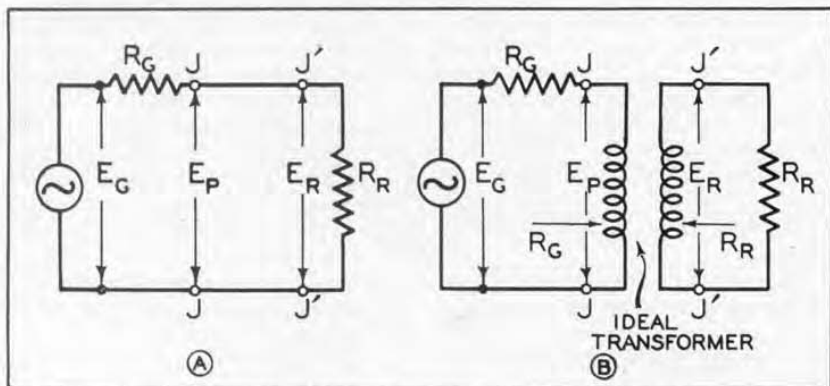

FIGURE 2. In general, the reference power for gain determinations is the load power when source and load are directly connected (as in *A*), but for gain as defined in the accompanying article an additional condition is imposed: R_G must be equal to R_R . The reference power may be obtained:

- (1) by use of an ideal impedance-matching transformer as in *B* or (2) by computing $\frac{E_G^2}{4R_G}$

which simply means that one-half of the power generated in the power source is available at the terminals of the output load under this reference condition. This is equivalent to determining it by means of an ideal transformer.

Sometimes all of the power that a given generator is capable of delivering is not *available* for use in operating any single amplifier. Suppose, as a specific example of this, it is necessary to shunt a monitoring amplifier across a telephone line. The input transformer of such an amplifier would be designed to have an impedance large enough so that it could be bridged across the line without drawing more than a certain allowable amount of power. However, regardless of its input impedance, it still draws some power from the line. This power is the *available power*, the power that must be used as reference condition when calculating the gain of the amplifier.*

*EDITOR'S NOTE.—This statement means that if the *maximum* amount of power the source is capable of delivering ($= \frac{E_G^2}{4R_G}$) is not *available* for use in the amplifier or network being considered, the previous remark about the "con-

If the grid of the first amplifier tube were connected directly to the line, the power absorbed would be, of course, very small, although the power delivered by the amplifier might still be quite large. In this case, the gain would be very great, but the definition would still hold.

In designing an amplifying or an attenuating network to work between a given generator and load, the input and output circuits of the network should match the two impedances respectively for the maximum efficiency. Often, however, this is impossible or impractical. It should be remembered that any loss caused by such mismatching is entirely chargeable to the network.

The most direct method of determining the gain or loss of a network on condition for maximum power transfer across the junction" must be interpreted with care. If *maximum* power is not *available* the network must be considered for both calculation and measurement purposes as working out of a new source whose *maximum* power is equal to the *available* power. In other words, E_G for the new source is the same as E_G for the old one, but the new R_G is given by the relation

$$R_G(\text{new}) = \frac{E_G^2}{(\text{Available Power}) \times 4}$$

the basis of the foregoing definition is to measure the output and available input powers, ten times the common logarithm of the ratio between them being the gain in decibels. If we know the characteristics of the input and output impedances, we find the powers by measuring either the voltages across, or the currents through, the two impedances.*

This method, because of a variety of difficulties encountered in practice, is for one reason or another, often not desirable. Nearly all measurements

* John D. Crawford, "Notes on Power Measurement in Communication Circuits," *General Radio Experimenter*, IV, October, 1929.

of gain and loss are made by comparing the unknown amplifier or attenuator with a calibrated network. Resistance networks can be accurately designed and once constructed do not change their calibration with time. For this reason they are excellent standards of comparison. There are a number of ways of actually making this comparison, but a complete discussion of these is beyond the scope of this article. For an example, refer to a previous article by the writer.†

† Arthur E. Thiessen, "Production Testing of Audio-Frequency Amplifiers," *General Radio Experimenter*, IV, June, 1929.

MISCELLANY

By THE EDITOR

THE line of TYPE 376 Quartz Plates manufactured by the General Radio Company has been completely reclassified. New prices are in effect and a new high-precision class for use with temperature control has been made available. A complete description of the TYPE 376 Quartz Plates will be published in the next issue of the *Experimenter*.

* * * *

When we described the new TYPE 547 Temperature-Control Boxes in the November issue of the *Experimenter*, we interchanged the Centigrade and the Fahrenheit values for the allowable variation in room temperature. Control will, of course, be obtained over

a room-temperature variation of 11 degrees C. or 20 degrees F.

We hereby tender our thanks to those readers who were good enough to call our attention to the error and hope that none of the others were misled by it.

CONTRIBUTORS

J. W. HORTON has been Chief Engineer of the General Radio Company since October, 1928. For the twelve years preceding he was with the Bell Telephone Laboratories where he obtained the information upon which this article is based.

ARTHUR E. THIESSEN is an engineer with the General Radio Company.

The General Radio *Experimenter* is published monthly to furnish useful information about the radio and electrical laboratory apparatus manufactured by the General Radio Company. It is sent without charge to interested persons. Requests should be addressed to the

GENERAL RADIO COMPANY
CAMBRIDGE A, MASSACHUSETTS

RUMFORD PRESS
CONCORD

