

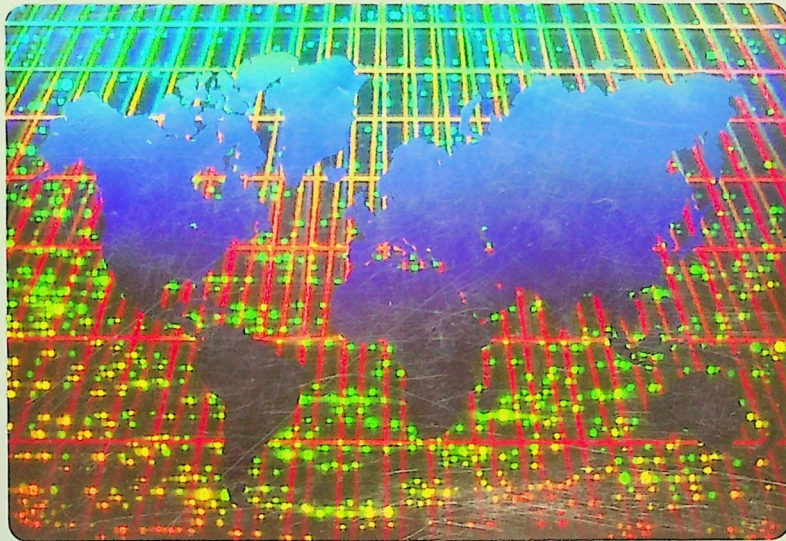

**WORLD CLASS PRODUCTS**



**WORLDWIDE SUPPORT**



10,000+  
Broadcast Products  
350+ Vendors

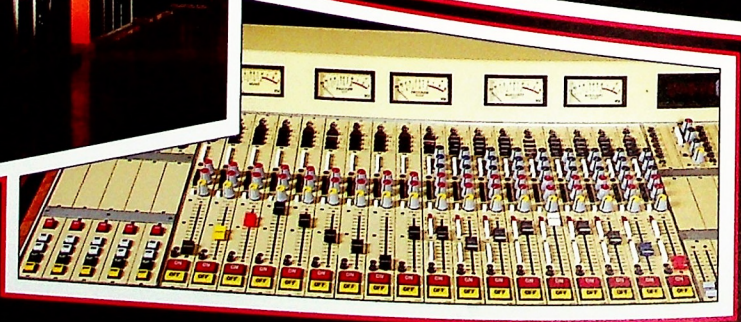
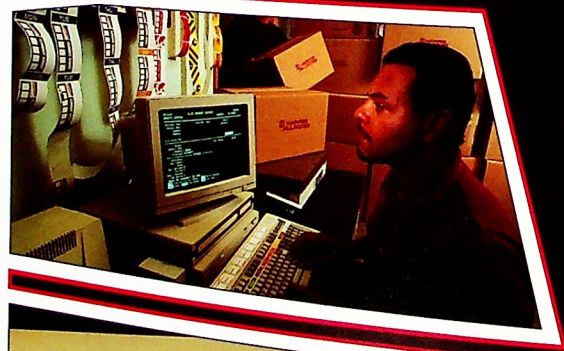

# Welcome To The World Of Harris Allied

o o e e	Mabuhay
ΕΝΩΝΙΣΜΟΣ	Willkommen
Dobrodošlica	Bienvenue
Velkommen	Tervetullut
Välkomna	歡迎
Fåilte!	Εὐπρόσδεχος
Verwelkomen	Bienvenido
Bem-vindo	Välkommen
Cuairteoir	Hoş Geldin!
기꺼이 받아들이다	Benvenuto
よろこぶ	ДОБРО ПОЖАЛОВАТЬ!

<u>CONTENTS</u>	<u>PAGE</u>
Amplifiers .....	1
Audio Processing .....	10
Automation .....	24
Cartridge Machines .....	31
Cartridges & Accessories .....	34
Cassette Recorders .....	39
CD Players, Recorders & Access. ....	41
Consoles & Mixers .....	47
Delay Lines .....	62
Digital Editing .....	63
Digital Recorders & Players .....	66
Distribution - Signal .....	74
Engineering Data & Tables .....	223
Furniture & Studio Accessories .....	79
Glossary .....	229
Headphones & Headsets .....	97
Intercom Systems .....	101
Interfaces .....	102
Microphones .....	106
Miscellaneous .....	235
Monitoring .....	115
RDS/RBDS .....	122
Reel to Reel .....	123
Remote Control .....	125
Remote Pick-Up .....	127
Satellite .....	129
Service .....	137
Speakers .....	140
Studio Transmitter Links .....	143
Systems .....	150
Telephone Interface .....	159
Test Equipment .....	169
Training .....	171
Transmitters - AM .....	174
Transmitters - FM .....	181
Transmitters - TV (VHF) .....	190
Transmitters - TV (UHF) .....	193
Transmitting Accessories .....	212
Transmitting Antenna - AM, FM & TV ..	200
Weather Equipment .....	222

**IMPORTANT ADDRESS/CONTACT INFORMATION**

**USA**

**STUDIO & SATELLITE PRODUCTS – USED EQ.**

HARRIS ALLIED BROADCAST DIVISION  
3712 NATIONAL RD. W. – P.O. BOX 1487  
RICHMOND, INDIANA 47375-1487

**PHONE:**

317-962-8596  
317-935-1704 (INTERNATIONAL)

800-622-0022 (DOMESTIC SALES)

**FAX:**

317-966-0623  
317-966-0402 (INTERNATIONAL)

**USA**

**RADIO/TV TRANSMITTERS & ANTENNAS**

HARRIS ALLIED BROADCAST DIVISION  
3200 WISMANN LANE – P.O. BOX 4290  
QUINCY, ILLINOIS 62305-4290

**PHONE:**

217-222-8200  
217-222-8290 (INTERNATIONAL)

**FAX:**

217-224-1439  
217-222-2764 (INTERNATIONAL)

**USA**

**STUDIO & PRO AUDIO EQUIPMENT**

HARRIS ALLIED BROADCAST DIVISION  
6430 SUNSET BLVD. – SUITE 650  
HOLLYWOOD, CALIFORNIA 90028

**PHONE:**

213-462-6622  
800-690-2828 (SALES)

**FAX:**

213-462-8468

“Specializing in Pro-Audio”

**CANADA**

**STUDIO, RADIO/TV TRANSMITTERS & SATELLITE**

HARRIS ALLIED BROADCAST DIVISION  
P.O. BOX 5002  
ST. LAURENT, QUEBEC H4L 4Z6

**PHONE:**

514-421-6272  
800-269-6817  
514-952-1630 (CELLULAR)

**FAX:**

514-421-2712

**ENGLAND**

**STUDIO, RADIO/TV TRANSMITTERS & SATELLITE**

HARRIS ALLIED BROADCAST DIV. - EUROPE  
515 COLDHAMS LANE – P.O. BOX 41  
CHERRY HILTON, CAMBRIDGE CB1 3JU,  
ENGLAND

**PHONE:**

44-0223-245115  
44-0223-415459 (STUDIO EQ)

**FAX:**

44-0223-214632  
44-0223-210441 (STUDIO EQ.)

**FRANCE**

**STUDIO, RADIO/TV TRANSMITTERS & SATELLITE**

HARRIS ALLIED BROADCAST DIV. - EUROPE  
47, avdes, GENOTTES – BP 8282  
95802 CERGY-PONTOISE CEDEX  
FRANCE

TEL: 1/49 91 02 31

TEL VOITURE: 07 03 52 40

FAX: 1/49 91 02 45

**SPECIALIZED/SPECIFIC PHONE/FAX CONTACT INFORMATION**

**LATIN AMERICA**

**USA**

**STUDIO, RADIO/TV TRANSMITTERS & SATELLITE**

**TV & SATELLITE SYSTEMS – MOBILE & FIXED**

**HARRIS ALLIED BROADCAST DIVISION  
6303 BLUE LAGOON DR. – SUITE 350  
MIAMI, FLORIDA 33126**

**PHONE: 305-266-8050  
800-2-255433 (MEXICO ONLY)  
FAX: 305-266-0401**

**HARRIS ALLIED BROADCAST DIVISION  
7920 KENTUCKY DRIVE  
FLORENCE, KENTUCKY 41042**

**PHONE: 606-282-4800  
FAX: 606-283-2818**

**ASIA/PACIFIC**

**WORLD CLASS PRODUCTS**



**WORLDWIDE SUPPORT**

**STUDIO, RADIO/TV TRANSMITTERS & SATELLITE**

**HARRIS ALLIED BROADCAST DIVISION  
73, LORONG ENGGANG, ULU KLANG FTZ  
54200 KUALA LUMPUR, MALAYSIA**

**PHONE: 603-4514593, 4514535  
FAX: 603-4514309**

**WORLD CLASS PRODUCTS**



**WORLDWIDE SUPPORT**

**TELEPHONE & FAX NUMBERS FOR SPECIFIC TYPES OF SERVICE OR AREA OF THE WORLD**

USA	FOR NEW STUDIO PRODUCTS: 800-622-0022 FAX 317-966-0623
USA	TO PROCURE-SELL-TRADE USED STUDIO EQUIPMENT: 317-962-8596 FAX 317-962-8961
USA	FOR TV/RF TECHNICAL SERVICE: 217-222-8200 EXT. 3177 FAX 217-222-7041
USA	FOR STUDIO TECHNICAL SERVICE: 317-962-8596 EXT. 234 FAX 317-962-8961
WORLDWIDE	FOR RF PARTS (24 HRS): 217-222-8200 EXT. 3500 FAX 217-222-7041
WORLDWIDE	FOR RADIO RF TECHNICAL SERVICE: 217-222-8200 EXT. 3528 FAX 217-222-7041
WORLDWIDE	FOR RADIO & RF SYSTEMS ASSISTANCE: 217-222-8290 FAX 217-222-7041
USA	FOR TV & SATELLITE SYS. ASSISTANCE: 606-282-4800 EXT. 4830 FAX 606-283-2818
USA	FOR SATELLITE AUDIO ASSISTANCE: 317-962-8596 EXT. 208 FAX 317-962-8961
MID-EAST-AFRICA EUROPE	FOR RF EQ. & SATELLITE (ENGLAND): +44-(0)223-245115 FAX +44-(0)223-214632
SO. CA-USA	FOR RADIO RF & STUDIO: 213-482-6622 FAX 213-462-8468
LATIN AMERICA	FOR RF, STUDIO, SATELLITE (MIAMI): 305-266-8050 FAX 305-266-0401
ASIA/PACIFIC	FOR RF, STUDIO, SATELLITE (KUALA LUMPUR): 603-4514593 FAX 603-4514309
CANADA	FOR RF, STUDIO, SATELLITE: 800-269-6817 FAX 514-421-2712
EUROPE/ ENGLAND	FOR RF, STUDIO, SATELLITE: +44-(0)223-415459 FAX +44-(0)223-210441
FRANCE	FOR RF, STUDIO EQ: 1/49 91 02 31 FAX 1/49 91 02 45
MEXICO	FOR RF, STUDIO, SATELLITE: 800-2-255433 FAX 305-266-0401

# HARRIS ALLIED - THE INDUSTRY LEADER

## INVITES YOU TO KNOW MORE ABOUT US



Harris Allied Broadcast Division (HABD) specializes in equipment and support services for the broadcast industry.



This catalog represents only a sample of the over 10,000 products and accessories that HABD distributes from more than 350 manufacturers.

In most cases only the briefest form of relevant technical specifications are defined for your review of the products listed herein; however, original manufacturers specification information/sheets are readily available and we will enthusiastically send them to you for your perusal of any product you have an interest in.



**TAKE ADVANTAGE OF OUR EXPERTISE!** Let HABD personnel assist you in selecting the most practical product or accessories for your specific situation from our vast inventory. Our resources come from a wide array of newly introduced technology, as well as well-founded, existing products from all our vendors and manufacturers.



We maintain a comprehensive inventory on virtually all major brands of professional audio gear, transmission gear, accessories and expandables for all your audio needs. HABD provides "off the shelf" delivery for most products for your convenience anywhere in the world. We place our confidence in United Parcel Post (UPS) and Federal Express (FedX) here in the US. We have confidence as well in other carriers to get your articles to you in an efficient, and timely manner. If it's not on our shelf, we can arrange for "drop ship" to your facility.



Again, HABD says — take advantage of our expertise — we usually have access to newly introduced, existing and sometimes recently discounted products from all our vendors (You've probably seen some of the "specials" in our Broadcast Communique' and/or Broadcast Express). In addition to these bargains, HABD also has an equipment exchange department wherein studio - audio gear is traded - purchased - sold, to give you cost savings for your budget, but more precisely the ability to "trade-in" your older or excess equipment and save even more of your hard earned monies.



Broadcast equipment in its simplest form or today's exotic technology can become a challenge in problem solving. So let your problems become a HABD challenge. We have complete in-house capability to troubleshoot, test and/or repair your gear with expedited turn-around and minimal downtime. We are also a factory-authorized repair facility for many name brand products and we provide field-service for our own Harris products. We also have available for you 24-hours-a-day, parts for Harris transmitters from our vast inventory.



Don't be bashful about seeking help from HABD to resolve your engineering problems. Our professionals stand ready to help you design, modify or install equipment/facilities to meet your requirements, whether it be Radio, TV, Satellite, mobile or fixed facilities. We are the leader in broadcast distribution and take pride in the fact we can do it all for you with essentially "one-stop-shopping". Your patronage, support and feedback keep us number one!



We can assist you numerous ways in the financial aspects of your purchase. Our in-house financial experts are here to help you secure the goods you need in the most economical way. Additional assistance is yours as well in the shipping and scheduling areas to meet your needs.

### HD1000/HD100 Headphone Amplifiers

The HD1000 is designed for attractive desk or EIA rack mounting singly or two side-by-side. The HD100 module is small enough to hang under a desk or mount behind a panel and attractive and rugged enough to place on top.

Drive directly four stereo headphone outputs from the HD1000 with a mix of a stereo line level input plus a panned front panel microphone input for adding paging, annotation or instructor comments.

Drive all types of headphones with efficient, quiet, high compliance, low distortion drive circuitry. Balanced, instrumentation amplifier line and microphone inputs provide low noise and excellent common mode hum rejection.

Loop the HD1000 into additional HD1000s for more groups of four outputs each. Daisy chain any number of small HD100s among various locations such as classrooms and offices.



HD100



HD1000

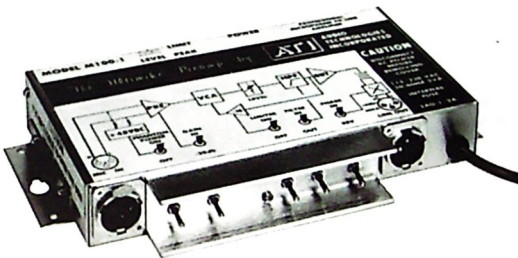

### M100 Microphone Amplifier

The M100 microphone amplifier eliminates dimmer noise, RF pick-up and hum loops. Mount this small, rugged, full-featured preamp right near the audio source. The unusually quiet, direct balanced, instrumentation amplifier input has impressive hum and RF rejection and accepts +20 dBm maximum input. Features switchable and adjustable gain, limiter, lo-cut filter, 48 volt phantom power and a phase reversing switch. XLR in and out, dual rack mountable.



### M-1000 Dual Microphone Amplifiers

The M-1000 Dual Microphone amplifiers provide two independent and totally isolated channels to drive a pair of 600 ohm outputs from 50 to 250 ohm impedance microphones. High gain, low noise, plenty of headroom and excellent shielding for outstanding RF immunity. Optional 48VDC phantom power.

M-1000-1 dual transformer outputs.

M-1000-2 balanced differential outputs.

M-1000-1P dual transformer outputs with phantom power.

M-1000-2P balanced differential options with phantom power.

### MLA/MMA 400/800 Multiple Amplifier Array

Four or eight individual channels to boost either microphone or line level balanced inputs up to +24dBm, 600ohm ohm line levels with active or transformer balanced outputs. Use as microphone, line buffer, IHF interface, audio distribution and level matching amplifiers. Drive headphones or interface phone lines. Combine channels with rear connector jumpers to form stereo summing networks, DAs, simple mixers or even a press box. Adjustable gain, up to 82dB mic and 42dB line. Low noise and distortion, ruler flat response. Barrier block terminals, 1-3/4" rack mount. Accessory XLR in-out panels available.



**MX100/XP100 Mic/Line Mixer**

The MX100 3-channel mic/line mixer and the XP100 4-channel mic/line input expander are compact, convenient and rugged series of low-cost NanoAmps from ATI.

Featuring professional XLR and TRS connectors with high-performance circuitry and quiet loop-thru external power, the NanoAmp Series includes single and dual microphone and line amplifiers, stereo headphone drivers, IHF - PRO Interface Converters in 4-channel and bi-directional models, and expandable mic/line distribution amplifiers.

The newest NanoAmps, the MX100 3-input mic/line mixer and its companion XP100 4-input expander feature low noise balanced inputs switchable for microphone or line levels, phantom power, an independent headphone output and a metered, high-level, low distortion, protected 600 ohm output for balanced or unbalanced lines.



MX100

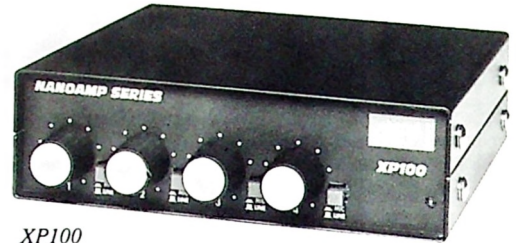

XP100

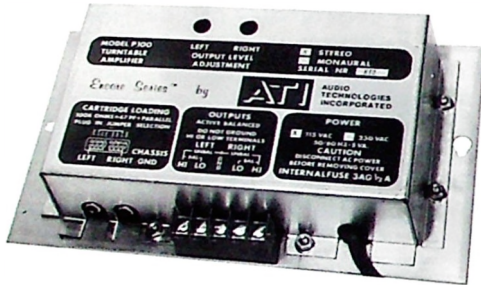

**P100S Stereo Turntable Amplifier**

No pretty paint or shiny pushbuttons but an economical, RF proof package wrapped around high performance circuitry makes this preamp a great value. A subsonic warp filter, DIP switch R and C cartridge loading, precision 1/2dB equalizer, low noise front end and a line isolated active balanced output makes this preamp your best buy.

**AUDIO-METRICS**

**TP-84 Turntable Preamplifier**

The Audio-Metrics TP-84 follows the RIAA curve to within 1 dB in its entire bandwidth while maintaining a signal to noise level of 70 dBm. Distortion figures of .08% make the TP-84 transparent to your turntable cartridge. Bracket mount included.



**BENCHMARK**

**HPA-1 Headphone Amplifier**

The Benchmark jack mounted amplifier series can be used *anywhere*. Use them in consoles, at the patch bay, in telephone talkshow roundtables and in test sets, wherever you need individual level control. The HPA-1 features a current boosted NE5532 with a 60 kHz bandwidth at full gain, a gain range of Off to +18 dB and a noise floor of -90 dBu, again at full gain. The HPA-1 is ideal for the "Studio Series" headphones in the 200 to 600 ohm range but will work with 8 ohm devices as well.

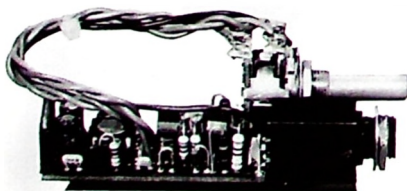

Specifications subject to change or revision.



## BGW



### 200 Stereo Power Amp

The BGW model 200 delivers 100 watts of power per channel into 8 ohms, high thermal efficiency in a compact 1 1/4" high, rack mounted, all aluminum chassis. Comprehensive input connections and gold plated binding post outputs.

### 85 Stereo Power Amp

The BGW model 85, rack mounted power amp offers 35 watts of power per channel into 8 ohms. Low feed-back circuitry enhances stability and reduces TIM. The output appears on a barrier strip for reliable, low resistance, low cost connections. Options available for balanced inputs.

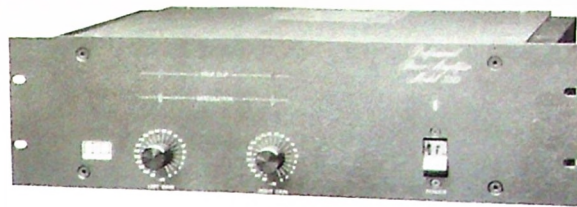

### 350 Stereo Power Amp

BGW's model 350 delivers 200 watts of power per channel into 8 ohms, about 1 3/4 dB less than its big brother, model 750. Offers all the refinements that reinforce BGW's reputation of low noise, low distortion and high reliability. Comprehensive input connections and switchable configurations. Rack mount, single piece steel chassis fits in just 5 1/4" vertical space. 350-A - LED Display.



## CARVER

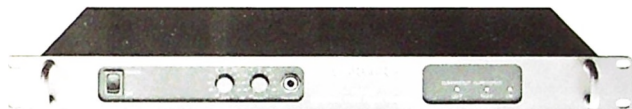

### PM-120 Stereo Power Amp

The PM-120, 60/60-watt magnetic field power amplifier is compact and lightweight. The PM-120 is designed specifically for high definition monitoring by the industry's most discriminating engineers. Featuring balanced XLR, TRS and terminal strip inputs. Carver's exclusive clipping eliminator circuit and front panel headphone jack, the PM-120 is the superior choice for any critical near field monitoring application.



### PM-300 Stereo Power Amp

The PM-300 is a 150/150-watt magnetic field power amplifier compact, powerful and reliable. With over 100 watt/ch. (8 ohms), this small, efficient power amp can drive the hungriest monitors with power to spare. Useful features like dual LED power indicators, front panel headphone jack and Carver's exclusive clipping eliminator circuit, make the PM-300 the obvious choice over bulky alternatives in this power class.

## CROWN



### D-150A-II Stereo Power Amp

The Crown D-150A Series II is rated at 80 watts per channel into 8 ohms. Frequency response is  $\pm 1$  dB DC to 100 kHz, less than .001% harmonic distortion, less than .01 I.M. distortion and 6 volts per microsecond slew rate.



### D-75 Stereo Power Amp

The Crown D-75 offers significant benefits to the professional user, benefits like active-balanced XLR connectors as well as unbalanced 1/4" phone plugs and signal presence indicators that notify the user whenever the D-75 output signal is greater than 1/8 watt. 35 watts per channel into 8 ohms.

## EDCOR

### HA 400C Headphone Amplifier

The four channel HA 400C performs well in broadcast studios, theatrical monitor and cueing systems, and audio/visual rooms. Each channel has an independent stereophonic power amplifier with its own gain control and provides you with high fidelity reproduction. The gain controls adjust the right and left ear equally. Phone jacks are designed with limiting resistors placed in series with the headphones to prevent "acoustic shock". Will accept auxiliary line level inputs such as tuners, pre-amps, monitors, and most unbalanced program sources. These inputs may be either stereo or mono. Rack mountable with an accessory rack mount kit. The vertical space required is only 1 3/4". 8 channel version also available.



## HAFLER

### PRO 1200 Stereo Power Amp

We feature Hafler's PRO 1200 because it delivers so much for so little. Sixty continuous watts per channel into 8 ohms packaged in 2 rack spaces plus 1/4" AND XLR inputs. All adjustments including level controls are on the back panel keeping them out of sight. Efficient and reliable, the Hafler PRO 1200 is priced right.



PRO 1200



### PRO 2400 Stereo Power Amp

The Hafler PRO 2400 delivers 125 watts per channel into 8 ohms. Generous over-sized heat sinks keep it cool plus the simplified circuitry gives total performance and reliability. Fits standard 19" EIA rack and measures 5 1/4" high and 10 1/2" deep, weighing 27 pounds.



### PRO 5000 Stereo Power Amp

The Hafler PRO 5000 sets new industry standards in professional power amps with performance and profitability. Its rugged and reliable due to enhanced forced-air cooling and unique circuitry protection systems of its solid state power MOSFET output devices. Fits standard 19" EIA rack and measures 3 1/2" high and 14" deep, weighing 40 pounds.

Hafler has a World Class 7-year parts and labor warranty and exchange policy.

## RAMSA

### WP-9055 Stereo Power Amp

Exceptional sound quality is engineered into the Ramsa WP-9055 amplifier. This amplifier is designed for inherent stability with any complex R-L-C load. Sophisticated "intelligent" protection circuits will not be "fooled" into shutting down. Enjoy exceptional high fidelity audio delivered from this 150 watt into 8 ohm unit. Rack mountable (19") with 2 5/8" height and 13 3/8" depth, weighing 19 lbs.



Specifications subject to change or revision.

# Broadcasters have great ears too.

Join the family of top American recording studio professionals using Hafler amplifiers. Treat yourself to the legendary name of Hafler, the most dependable studio amplifier available.

Why buy just another good amp when you can enjoy our "rich, elegant studio reference audio quality" at prices that will fit your budget. Just ask the experts at Harris Allied.

Hafler amplifiers. *The standard.*

# Hafler®

A DIVISION OF ROCKFORD CORPORATION TEMPE, ARIZONA 85281 USA



*"Jim Strickland's simple (less is more) design of the trans-nova makes it the most uncolored power amplifier I have heard. It doesn't add or take away from the music. For me this makes the trans-nova an ideal monitoring tool."*

TOM JUNG  
DMP RECORDS



*"For the past ten years, I've used Hafler amplifiers here at Capitol's 'Tower Mastering'. I'm more than pleased with the sound quality and dependability they provide. The many artists I've mastered, know they can rely on our monitors when they're powered by Hafler."*

WALLY TRAUGOTT  
TOWER MASTERING  
CAPITOL RECORDS



*"Here at Conway we have 21 Hafler amplifiers that don't lie...and both of my systems at home are built around Hafler components."*

JOHN HURST  
TECHNICAL DIRECTOR  
CONWAY RECORDING STUDIOS



*"...Once in a while a product comes along that is an incomparable value. Hafler power amps fit squarely into that category: pure abundant transparent power amplification, no gimmicks, and no high price tag. If only all equipment decisions were so easy...."*

PAT SCHOLES  
DIRECTOR OF ENGINEERING  
ARDENT STUDIOS



*"...One might ask why I chose Hafler, when with the budgets I've had I could have spent thousands more on esoteric amplifiers. The answer is simple. I think for the money spent, these are the finest amplifiers obtainable. ...Hafler amplifiers... The Standard...."*

PATRICK WEBER  
RECORD PLANT, MCA RECORDS,  
CAPITOL RECORDS,  
PATRICK WEBER ENGINEERING

## RAMSA

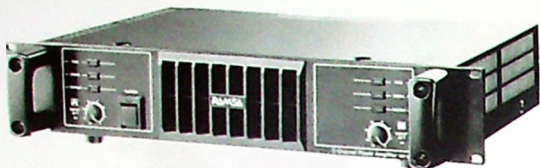
**WP-9110 Stereo Power Amp**

The WP-9110 is another reliable, power-rated amp from Ramsa. This unit of 150 watts into 4 ohms has circuits with inherently low distortion and precision-matched components for higher common mode rejection. The WP-9110 is also operable in any of 3 modes: STEREO, MONO or BRIDGE. The heat transfer system is augmented by a full-time fan. Rack mountable (19") with 3½" height and 15¼" depth, weighing 28.6 lbs.

**WP-9220 Stereo Power Amp**

The Ramsa WP-9220 amplifier is exceptionally reliable and its high slew rate and controlled rise time minimize RF and oscillation problems without causing transient intermodulation distortion. Its dual-voltage "super rail" design allows beneficial effects on stability and sound quality. Multiple protection systems are inherent in this 300 watt into 4 ohm or 200 watt into 8 ohms powered unit. Rack mountable (19") with 5¼" height and 15¼" depth, weighing 38.6 lbs.

## RANE

**Model MS 1 Microphone Preamp**

The Rane MS 1 Mic preamplifier provides the answer when you need just one microphone input in an otherwise line-level world. Give us a call to go from either a dynamic, condenser or electret microphone to a line level input with a minimum of noise, distortion, cost and hassle. The MS 1 provides 48V switchable phantom power with indicator LED, continuous rotary gain trim between 20 dB and 60 dB, overload LED, 3-pin mic input connector, balanced tip-ring-sleeve ¼" output and two remote power supply connectors.

The model RS 1, a U.L. approved outboard power supply, is included with each MS 1 preamp.

**HC-6 Headphone Amplifier**

The rack-mount HC-6 offers more performance and flexibility than you ever hoped for. Designed into the HC-6 are separate inputs for each of the six stages, which individually bypass the master stereo inputs. The HC-6 can handle up to six totally separate programs for many additional applications including custom headphone monitor mix. All outputs may also be fed from one input.

**Model FMI 14 Mixer Input/Microphone Preamp**

Rane's Flex Series Model FMI 14 Mixer Input module is a complete mic mixing input channel. Configured as a single input, four output (Master A/B & Aux A/B) mixer module, the FMI 14 becomes the crucial input building block for assembling any size mixer. The FMI 14 mic preamp performance is comparable to the best mixing boards.

When combined with the Flex Series Master Module, FMM 42, via the supplied DIN bus cables, any number of input channels may be racked together to create any size mixer.

Power is supplied through its 6-pin modular connector. This power may be from either a Model RS 1 single power supply included with each FPE 13 or a Rane FRS 8 Remote Power Supply. As pictured, unit is made to mount in optional FVR10 mounting assembly. Other mounting options available including standard 19" rack mount.



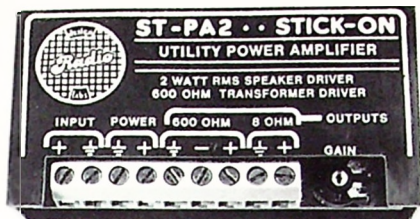

### ST-PA2 Utility Amplifier

The RDL ST-PA2 features a single, unbalanced audio input, a gain control and two outputs. The first output is designed to deliver a clean 2 watts RMS into an 8 ohm speaker. The second output is intended to drive 600 ohm transformers, typically on equipment inputs. This makes the ST-PA2 suited to applications such as music-on-hold inputs on telephone systems which may have either 8 ohm or 600 ohm inputs. Both outputs may be used at the same time.



### ST-PA6 Power Amplifier

The RDL ST-PA6 features two balanced audio inputs, a gain control, equalization control and an 8 ohm output. The output is designed to deliver a clean 6 watts RMS into an 8 ohm speaker. Each input is a balanced bridge, with the two inputs actively mixed (equally). This is particularly useful for monitoring a stereo line. The output stage features protection against short-circuits and thermal overload. The output protection automatically resets once the condition is removed.



### ST-PH1 Stereo Phono PreAmp

The ST-PH1 is a stereophonic phono preamplifier. Each of the two channel circuits are identical. The ST-PH1 has standard 47K ohm impedance unbalanced phono cartridge inputs. Each output drives either a balanced or unbalanced line. Equalization follows the RIAA curve. The output is capable of driving into either high or low impedance loads, and the output may be connected either balanced or unbalanced.



### ST-SH1 Stereo Headphone Amp

The ST-SH1 allows bridging any audio line, adjusting the gain and driving any impedance headset. The circuit design allows the input to accept either balanced or unbalanced signals, of either high or low impedance. This is an "instrument type" input stage which will amplify the differential input, regardless of ground reference. The ST-SH1's superior circuitry produces the unsurpassed pure clarity for which Radio Design Labs stick-on series of products are known.

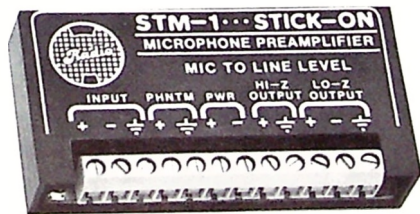

### STM-1 Microphone Preamp

The STM-1 is a low-cost quality microphone preamplifier designed for use in commercial sound and broadcast applications. The compact size makes it ideal where larger or heavier preamp cannot be used. The high performance circuit provides a fixed 50dB gain to bring any mic level signal up to the line level range of nearly any line input. For intercom applications, the input will operate directly from a speaker.



### STM-2 Microphone Preamp

The STM-2 is a quality low-noise microphone preamplifier designed for use in commercial sound, broadcast and recording applications. The STM-2 is very flexible with gain adjustment from "off" to 65 dB, two balanced or unbalanced outputs and available phantom supply input. Its compact size makes it ideally suited to locations where a larger or heavier preamp cannot be used. The single-ended supply input is ideal for both permanent and mobile equipment installations.



### FP11 Microphone -To Line- Amplifier

The FP11 is a portable, in-line amplifier designed to provide up to 84 dB of gain so that microphone and auxiliary level devices can be run at line levels. The FP11 is ideal for use in broadcasting and film and video production where long lines must be driven at higher than microphone or aux levels. The FP11 can also be used to interface equipment requiring different signal levels. Measures  $3\frac{1}{16}'' \times 5\frac{2}{32}'' \times 2\frac{3}{16}''$ , weighing 1 lb. 2 oz.



### FP12 Headphone Bridging Amp

The Shure FP12 is an in-line, 9V battery-powered amplifier accepting microphone or line-level signal; bridge it, and produce strong signals to drive headphones at loud levels. It can be used to provide multiple headphone feeds, a two-station intercom, extra power for existing headphone circuits or a means of practicing electronic instruments through headphones. Measures  $3\frac{3}{16}'' \times 5\frac{1}{16}'' \times 2\frac{3}{16}''$ , weighing 1 lb. 2½ oz.



### M64A Stereo Preamp

The M64 is a compact, professional stereo preamplifier which solves a variety of preamplification and equalization problems. A three-position slide switch selects different equalization: Phone position, the M64 provides standard RIAA equalization. Tape position, playback heads on tape recorders are provided with NAB equalization. Flat position, the M64 can be used as a microphone preamplifier or a low-gain buffer amplifier where long cable lengths are necessary. All input and output connectors are standard phono jacks. The M64 can be powered by an external 24-36 Vdc Battery Power Supply. Note: M64-2E available for 216-264 VAC application.



### FP22 Stereo Headphone Amplifier

With the FP22, you can have professional quality stereo headphone monitoring without interrupting the signals being monitored. It is perfect in any situation from field production to studio recording packaged in a 1 lb. die-cast case measuring  $3\frac{3}{16}'' \times 2\frac{3}{16}'' \times 5\frac{1}{16}''$  using 9V battery power, so it can go anywhere. You can mix mono and stereo signals any way you want; also has "loop through" bridging for "chaining" multiple units.

**Harris Allied**

**The broadcast industry's source for state-of-the-art equipment.  
Use Visa or MasterCard — Phone or Fax your order today.**

**In The USA Phone: 800-622-0022 Fax: 317-966-0623  
See Pages B & C for Worldwide Contact Information**

## STANTON



The Stanton 310B preamp features universal mounting by special brackets, instant selection of flat or NAB post-emphasis curves, switchable effective rumble filter, individual adjustment of gains and high frequency responses, trimming of the capacitive cartridge loading at the input and immunity to external magnetic AC fields.

## SYMETRIX



### SX202 Microphone Preamp

The model SX202 dual microphone preamplifier is an ultra-clean two channel stereo/mono preamp, ideally suited for broadcast use. Built around the same chip used in a well-known recording console widely acclaimed for its exceptional sound quality, the SX202 makes world-class performance affordable. Used in place of older preamp designs, the SX202 offers substantial sonic improvements with its solid stereo imaging (less than 10° phase shift at 20 kHz), excellent transient handling (its positive and negative slew rates are symmetrical), very low noise (approaching the theoretical limit), and almost immeasurable distortion (.007%).



### SX204 Headphone Preamp

The model SX204 headphone amplifier is a 1-in 4-out stereo device, specially designed to drive multiple headphones of any impedance because each listener has control over the volume in his own headphones. Along with the individual level controls, an overall input level control is provided. The SX204's four independent stereo amplifiers can drive even high impedance headphones to maximum levels without distortion.

### A-220 Stereo Power Amp

The model A-220 stereo amplifier is a compact, high performance power amplifier designed for continuous duty use in professional audio systems. Used as a two channel amplifier, it delivers up to 20 watts per channel, both channels driven into 4 or 8 ohm loads. As a single channel amplifier the A-220 is capable of 40 watts, bridged across an 8 ohm load. Intended for use in medium power applications that require exceptional quality and reliability, such as audio monitoring, near field studio monitors, and for headphone monitoring.



A-220

## YAMAHA

### P2075 Stereo Power Amp

The Yamaha P2075 stereo power amplifier is the solution for the music and audio professional who demands reliability, versatility and Yamaha sound quality. Features rack type front panel handle, special output relay for speaker protection, electronically balanced differential input circuits, dB-calibrated input attenuators and comprehensive overload, transient and DC offset protection circuitry. Power output is 50 watts per channel into 8 ohms.



**AIR CORP**



**Pro Announcer 500PH Microphone Processor**

The Pro Announcer 500PH uses the latest and most advanced monolithic circuitry to provide impressive processing power with unmatched stability and reliability. From the unique selectable-gain monolithic front end with its integrated overvoltage protection, to the "popless" remotely insertable effects send, to the servo-balanced output stage, the Pro Announcer 500PH, which now includes a phantom power supply, exemplifies the state of analog processing art.



**Model 500-TV Microphone Processor**

The Air Corp Model 500-TV microphone processor was designed to solve the most common audio micing problems in TV studios and on remotes. Its three-band equalizer is specially configured to address the problems presented by off-axis and partially obscured lavalier microphones, as well as normal booth micing. The "electronic wind screen" processes the spoken word without coloring the processed material. Accommodates any dynamic, condenser or ribbon mic.

**APHEX**



**Model 104 Aural Exciter**

The Aphex Aural Exciter Type C<sup>2</sup> Model 104 offers improved circuitry making it quieter, more musical and easier to set up and use. It also features Big Bottom, a new circuit which increases the "perception" of low frequencies without substantially increasing the peak output level. The harmonic controls feature tune; mix; overhang and girth.



**Model 250 Aural Exciter III Dual Channel Processor**

The remarkable Aphex III studio aural exciter is a unique proprietary audio processing device that makes use of highly advanced psycho-acoustic principles to effectively restore and enhance audio presence, brightness and intelligibility. Designed specifically for on-air use, this unit provides AM stations with the clarity and brightness of FM.



**Compellor 320 Compressor/Limiter**

The Model 320 Compellor features dual monaural circuitry providing two independent channels. The 320 uses patented control circuitry as well as reference level switching from the rear panel; leveling speed switchable from the front panel; peak limiter defeatable from the front panel; two remote controllable bypass relays. To find out how the Compellor 320 can be called the automatic "fader" in a box...call us today.



**Digicoder™ Stereo Generator**

The Aphex Digicoder™ Stereo Generator provides unequaled sonic transparency of Class A analog with the separation and stability of digital and sustains maximum loudness. Plus it interlaces to your existing equipment with no A to D convertor. The Digicoder is easy to use and requires no maintenance.



**Dominator II Peak Limiter**

Aphex Dominator™ II precision multiband stereo peak limiter models 720, 723 were designed to fit a wide range of audio applications. Through the use of multiband techniques along with new proprietary circuits, the audibility of limiting action has been greatly reduced, especially when compared to conventional limiters. Greater limiting depth is possible, resulting in higher loudness with maintained audio quality. At virtually any limiting depth, the Dominator II is free of "hole punching", "dullness", and most other effects normally associated with limiters. As a peak overshoot protection limiter, the Dominator II is undetectable in line while it absolutely prevents levels from exceeding a user settable output level. Model 723 offers pre/de-emphasis.



**Expressor™ Compressor/Limiter Model 651**

The "sound" you were looking for... get it fast... get it clean with fully adjustable controls and unparalleled audio performance with the Model 651 Expressor™. The selectable "SPR" (Spectral Phase Reflector) function is a totally new and exclusive feature for a Compressor - Limiter. The SPR phase advances the critical bass frequency range without adding any bass level boost. SPR can often bring unprecedented clarity and depth to voices and smooth out the effects of compression or limiting. Another exclusive feature is HFX (High Frequency Expander) which compensates for "dullness" associated with compression and limiting. Call for complete information and specifications.

*Let Harris Allied assist you with your processing requirements.*



# The Aphex Audiophile Air Chain



## Higher Quality *and* Extended Coverage!

Smart broadcasters know that quality sound is essential to attract and keep loyal listeners ... and advertisers.

That's why premier stations around the U.S.A., and around the world, rely on the Aphex Audiophile Air Chain.

Now there's one more reason to turn to Aphex — better coverage of your listening area.

Stations that have installed the powerful combination of the Aphex *Compellor*® Model 320, *Aural Exciter*® Type III, *Dominator*™ II Model 720 and the *new Digicoder*™ digitally controlled stereo generator — as well as their listeners — are raving about better signal quality and a reduction in multipath.

*"A surprise bonus has been the apparent increase of coverage in fringe areas — we are getting very positive responses from listeners in Sacramento, 100 miles away,"*

- Tim Pozar, CE, KKSF-FM, San Francisco.

*"Immediate improvements in fringe signal quality were noted. These improvements included a reduction in multipath and picket-fencing,"* - Gary Greth, CE, KLON, Long Beach, CA.

**APHEX** *Improving the way the world sounds*<sup>SM</sup>  
SYSTEMS

Compellor, Dominator, Aural Exciter and Digicoder are trademarks of Aphex Systems Ltd.

©Aphex Systems

*"We have gotten a few responses from listeners in the fringes of our coverage area saying our signal is much stronger. They are reporting the actual carrier level has increased and they can hear us where they could not get a clear signal before."* - Herb Squire, CE, WQXR, NYC.

The Aphex Audiophile Air Chain allows maximum loudness and modulation while maintaining the natural dynamic feel of the program. Quick and easy to set up, it maintains the same high quality regardless of the type of programming or who is controlling the board.

Other processors need to be tuned for almost every song, and achieve loudness only by crunching to the point of listener fatigue. But Aphex helps you reach more listeners — and keep them longer.

If you want to be a winner in the "no win modulation wars", contact Harris Allied to arrange a demonstration of the Aphex Audiophile Air Chain. You can't buy better quality at any price.

**APHEX**

**Series 9000/9901 Modular Audio Processing**

The Aphex 9000 Series provides the features of their standard units in the space-saving convenience of all position 3-rack unit modular frame. The Aphex Modular Rack System can hold 11 Aphex or dbx compatible modules. The 9901 represents the next generation in audiophile tone shaping and retains the musical qualities of the EQ providing greater flexibility. Three overlapping bands of fully parametric equalization, each with 15 dB boost or cut. Peak or shelf filter shapes on each band allows for even greater tonal possibilities. Output clip LED indicator. The 9000 Series also includes:

- 9251 - Aural Exciter Module
- 9301 - Compellor Module
- 9621 - Expander/Gate Module
- 9651 - Expresor Module
- 9721 - Dominator II EQ Module
- 9901 - Parametric EQ Module

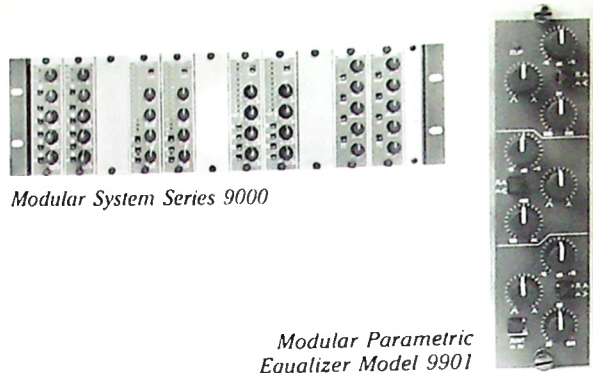

Modular System Series 9000

Modular Parametric Equalizer Model 9901

**ART**



**Model 472 Multiverb Alpha**

The Model 472 Multiverb Alpha offers a level of resolution that provides professional sound quality. Get effect combinations without compromise - reverbs, chorusing and flanging with up to 4 times the density of algorithms previously available. Among the more than 60 effects available mix and match at random up to 7 at one time. The new 24 bit architecture and easy-user interface make the Multiverb Alpha a whole new concept in digital processing, and allows you to get creative with immense power.



**Model 520 MDC 2001 Stereo Master Dynamics Controller**

The MDC 2001 is a total signal system controller for any application that requires compression, limiting, expansion, noise gating, de-essing, signal enhancement, sibilance correction or any related functions. The MDC 2001 offers two channels of stereo processing with over 45 LEDs to monitor all functions and level variations. Each function is isolated to access what is needed with no need to tune by trial and error. A switchable detector loop is available for gating, keying or ducking functions. Weight 11 lbs.

**CRL**



**Amigo FM Stereo AGC/Limiter/Stereo Generator**

The Amigo is a new concept in FM audio processing systems. This single rack high unit contains a complete audio processing system — flexible, powerful and easy to set up. The Amigo is a combination of dual band AGC with variable pre-emphasis multi-band limiter and digitally synthesized stereo generator. The wide range of the AGC ensures precise level control over a variety of program material. Following the AGC section, there is a powerful multi-band limiter and audio low-pass filter section. The unique limiter/audio low-pass configuration provides exact peak modulation control while maintaining outstanding program clarity.



**Amigo AM Audio Processing System**

The Amigo AM is a complete audio processing system for C-QUAM<sup>®</sup> AM stereo. CRL has taken the best technology, combined it into one high performance unit designed to be economical, powerful yet simple to use. Installing this AM stereo audio processing system has been made easy with a handy input meter which allows for quick adjustment of the input level. Outstanding features of the Amigo AM include a dual band AGC, patented 3 band stereo matrix limiter, single channel limiting, NRSC output filtering plus a full set of processing controls.

**Audio Signature Stereo AGC/Compressor**

The CRL Audio Signature is a fully software-controlled wideband and four band audio processing system in one package. Ideal for FM, AM stereo, TV and production applications. A major feature is an easy and accurate recall of all sound setting controls which have been previously stored in memory. PC and automation remote control capability. Combine the power of digital with the best of analog.

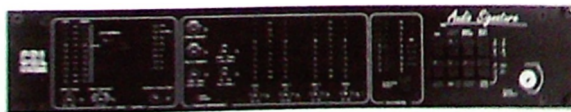

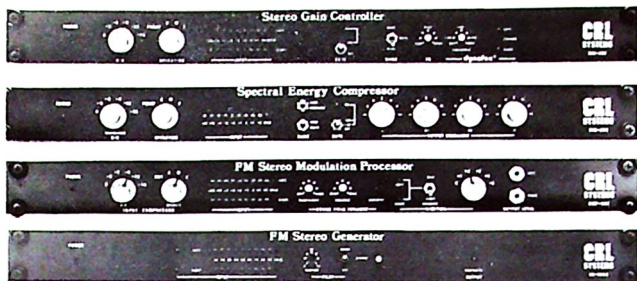

### FM-2g/FM-2g+ FM Processing

The CRL-FM processing systems are modular and include either three or four of the following basic signal processing concepts: 1) Stereo Generator (SG-800A); 2) Input AUDIO GAIN CONTROL (SGC-800); 3) STEREO Peak Modulation Limiting (SMP-850); 4) Optional MULTIBAND COMPRESSION (SEC-800).

For basic FM stereo signal processing, CRL offers the FM-2g system which includes the SG-800A Stereo Generator, the SGC-800 Stereo Gain Controller and a revolutionary FM final limiting device, Model SMP-850. This device offers absolute FM over modulation control and superior stereophonic sound capability. As a main feature, it includes a unique stereophonic sound field expansion system which intelligently increases received stereo separation of FM broadcasts. The larger FM-2g+ system contains the above units and additionally one Model SEC-800 four band audio compressor.



### BAP-2000 Mono AGC/Limiter

The CRL BAP-2000 monaural audio processor is an advanced dual band audio AGC and limiter in a slim 1 3/4" package. The design of the BAP-2000 allows it to be used in a wide range of FM & TV applications. Single ended noise reduction dynafex<sup>®</sup> is included.

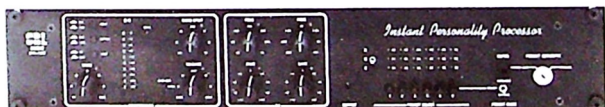

### IPP-100 Microphone Compressor/EQ

The IPP-100 is the easy way to get digitally-controlled power with the touch of a knob. Controls look and work like ordinary analog adjustments; has a wide range built-in mic pre-amp that feeds a two-band constant Q graphic equalizer. Select your settings — then store them in one of 18 memories. An optional remote control box is available.



### MBL-100 Mono SW/News-Talk Processor

The MBL-100 is designed to increase loudness and coverage area of AM monaural news/talk/sports formats with powerful audio processing topology. Special correction controls have been included to maximize modulation performance and in addition, a special test signal allows easy set up.



### AM-2/AM-4 AM Processing

The CRL-AM processing systems are modular and consist of either two or three of the following basic signal processing concepts: 1) Input AUDIO GAIN CONTROL (AGC-400); 2) Final PEAK MODULATION LIMITING (PMC-450); 3) Optional MULTIBAND COMPRESSION (SEC-400).

This system contains the model AGC-400 Audio input Gain Controller. The larger CRL AM-4 systems provides the maximum transmission signal coverage capability while maintaining the best audio quality. This system contains the above units and an additional Model SEC-400 four band audio compressor. The AM-2 and AM-4 are both NRSC compliant.



### DX-1 Mono Noise Reduction System

The Dynafex model DX-1 incorporates patent pending noise reduction circuitry that provides up to 30dB of noise reduction without the encode/decode process. DX-1 provides a single channel of noise reduction, while allowing the user several control parameters to fine-tune the device to exact requirements.



### DX-2 Noise Reduction

The CRL Dynafex model DX-2 incorporates patented noise reduction circuitry that provides up to 30dB of noise reduction. It is a two-channel device that will operate as a full stereo unit with both channels tracking together, or it may be used in the mono mode. The DX-2 can be utilized with -10, 0, +4 and +8dB reference levels. Rear panel XLR connectors.



### PMC-450 Peak Modulation Controller

The CRL PMC-450 tri-band Peak Modulation Controller offers state-of-the-art circuitry coupled with precise implementation of the NRSC standards for the loudest, cleanest signal on the AM dial. The PMC-450 consists of a powerful input compressor with over 20dB of input range followed by a tri-band limiter section and NRSC compliant low-pass filter.

# the unity 2000*i*

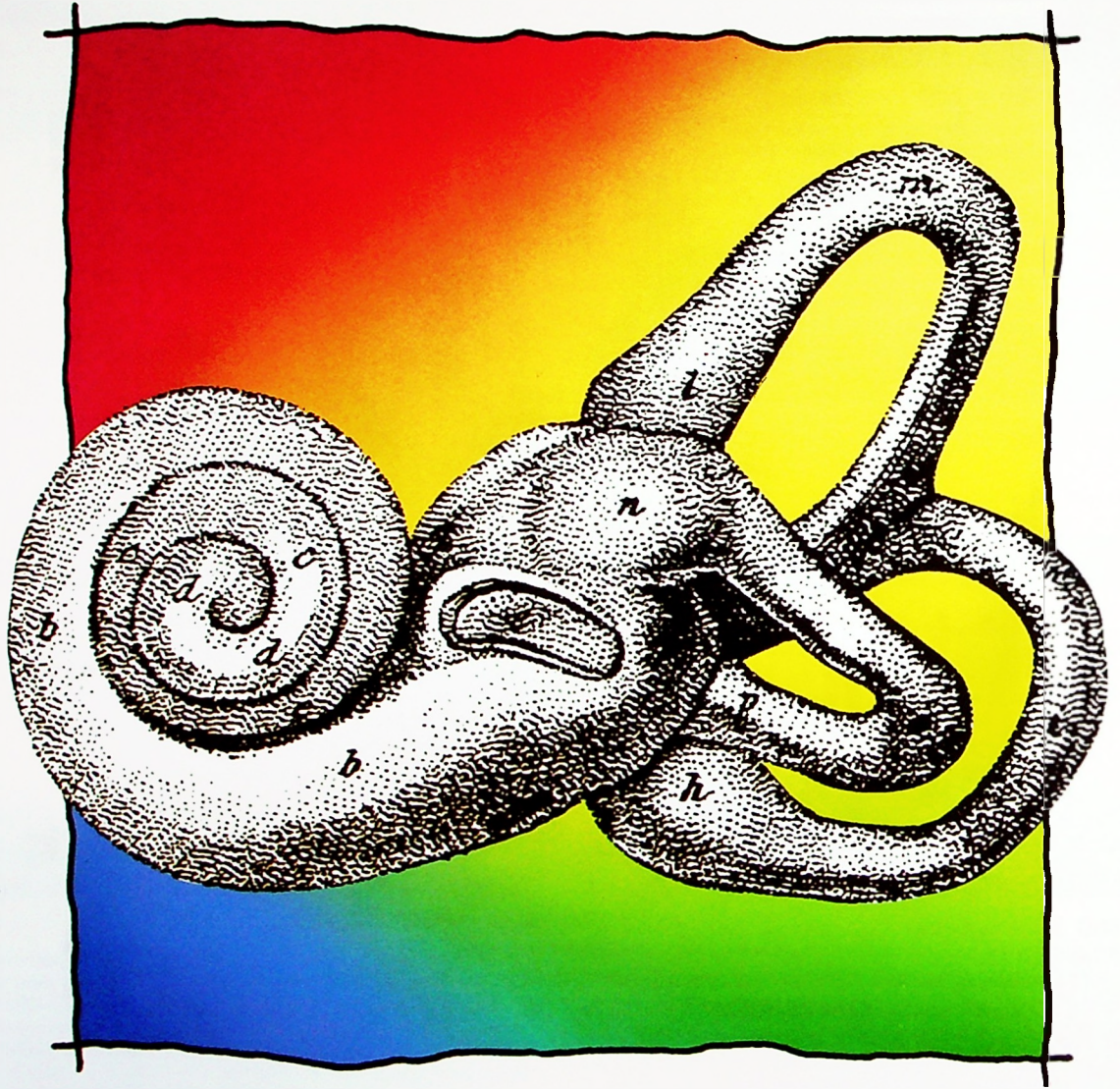

the world's **best sounding fm processor**



CUTTINGEDGE



## Unity 2000i FM Processor

The Unity 2000i FM, designed by processing expert Frank Foti, uses advanced digital signal processing techniques to achieve an open, accurate sound over the full range of processing. Feed forward control circuitry and Cutting Edge's unique Linear Response Algorithm<sup>®</sup> give a more musical high end and audio that never sounds harsh or synthetic. Nine processing functions are operated by a single control interface. Nine presets are included and allow you to create up to 50 settings. Features include: comprehensive front panel metering, four level security, day-part processing and an RS-232 port for computer control from virtually anywhere.



## Dividend FM Composite Filter

The Dividend Composite Filter from Cutting Edge Technologies is for stations using subcarriers for RBDS, data services or other applications. Also the Dividend is for stations that use a microwave STL, or are using composite clipping in their processing, want to regain lost modulation or seek to reduce multipath related distortion. The Dividend is a composite filter that reduces noise in the upper composite spectrum from 53kHz to 99kHz. The Dividend makes it possible to achieve a noise floor of greater than -60dB, provide clean SCA environment for the most demanding subcarriers and allows you to legally increase your modulation as much as 5 percent.

## DBX



## 140X Stereo Type-II Noise Reduction

The 140X provides more than 40dB of noise reduction for media such as cart machines, telco lines, videotape audio tracks and low bandwidth digital systems. The system is virtually immune to phase shift related tracking problems. It provides two channels each of encode and decode electronics in a single package.



## 160XT Mono Compressor/Limiter

The dbx160XT has all the features the industry loves including XLR connectors in place of barrier strips, with balanced inputs and outputs. Separate output circuitry allows independent, isolated feeds. Other extras include True Power Summing, for stereo linking, and a convenient Ground Lift Switch.



## 163X Compressor/Limiter

The model 163X is an easy-to-use compressor designed for the working musician — not to mention vocalist, sound contractor and anyone who needs a friendly compressor/limiter/preamp. Compression is controlled by a single slider on the front. LEDs confirm what's happening, while a thumb control adjusts the overall operating level up and down.



## 166 Stereo Compressor/Limiter

The dbx 166 Stereo compressor/limiter can also be used for dual mono operation. It features noise gate with switchable release rate, PeakStop for good-sounding "intelligent clipping," variable OverEasy compressor with  $\infty:1$  effects, sidechain monitoring.

## 266 Two-Channel Compressor/Gate

The dbx 266 is a full-featured, high-performance dual compressor/gate that uses newly developed dbx AutoDynamic™ attack and release circuitry to deliver true, musical dbx compression for a wide range of applications, plus an advanced new dbx gate circuit which overcomes the functional limitations of traditional "utility" gates. Separate precision LED displays for gain reduction, compression threshold and gate threshold allow quick, accurate setup.



Model 266

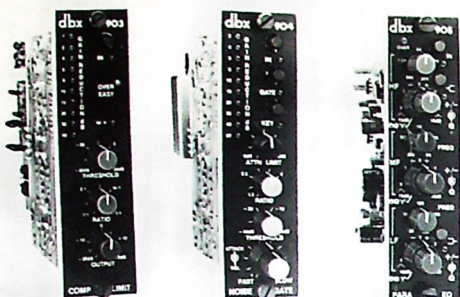

### 900 Series Modular Signal Processing

DBX has created the Series 900 modular signal processing system. The 903 compressor with its OverEasy compressor gives smoother, more listenable compression. The 904 noise gate is the ultimate noise gate, with a combination of features not found on any other noise gate. Features like adjustable attack and release rates, threshold adjustment from -30 to +30 dB, attenuation limit adjustment from 0 to 60 dB. The 905 parametric equalizer features 3 simultaneous bands of equalization, infinite notch on each band and shelving or contour on Hi and Lo. Series 900 is made to fit the optional F900A and FS900 mainframe enclosures.

### EVENTIDE



#### H3000B Broadcast Harmonizer

With the power of TWO top-of-the-line Eventide Harmonizer®, PLUS a complete high-end digital reverb and effects processor, the Ultra-Harmonizer® is radio's "special effects department in a box."

The H3000B gives you over 60 built-for-broadcast-production presets, including reverbs, effects, pitch-change programs, even sound effects. The 14 algorithms include three developed especially for radio: Time-Squeeze® for stereo time compression/expansion and machine control; Stutter and Patch Factory.

Now you can add six more algorithms — Vocoder, Reverb II, MultiShift, Band Delay, String Modeller and Instant Phaser® — PLUS over a hundred new presets, with the SE ConKit. The HS322 Sampling Board Option turns your H3000B into a CD-quality, 11.8 second stereo (23.7 second mono) sampler. Eventide keeps putting more into the Ultra-Harmonizer, so you can get more out of it.

Professional Eventide audio products available through Harris Allied include: H3000-SE Studio Enhanced Ultra-Harmonizer; H3000-SE/V; H3000-SE/B; H3000-SE/B/V and H3000-S Studio Ultra Harmonizer which includes VAI presets.

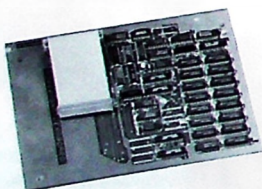

#### HS322/HS395 Internal Sampler Boards for the H3000 line

The HS322 and HS395 Internal Sampler Boards have Eventide's world-renowned pitch change technology, flexibility available from no other sampler. Each of the two segments can be independently pitch shifted without changing its length. MIDI notes can control the pitches of the two samples, and the length of each sample can be independently changed without altering its pitch. A standard sampling mode, which changes pitch by simply changing the playback rate, is also implemented. The HS322 and HS395 are compatible with all versions of the H3000 Ultra-Harmonizer line. Either board is available as an option on new units or as a factory retrofit to existing H3000s.



#### H3500 Ultra Harmonizer

The H3500-B Dynamic Ultra-Harmonizer® brand effects processor is Eventide's newest special effects device designed specifically for broadcasters. The unit features all the benefits and programs of an H3000-B; the exciting broadcast "extras" that make the H3000-B a powerful tool for radio and television professionals; the new Mod Factory algorithms which add dynamics, gating, ducking and compression; more than 100 new presets written by friends of Eventide from the recording, performing and post-production industries; plus up to 95 seconds of digital sampling.

The BCONKIT, which is included in the H3500-B, adds the special broadcast features of the H3000-B — three algorithms and 80 presets including TimeSqueeze® time compression/expansion software, Stutter, and Patch Factory — to make the H3500-B ideal for spontaneous on-air use. The H3500-B is available in two versions; the H3500-B dfx dynamic Ultra Harmonizer with a 22 second sampling board and the H3500-B dfx/e dynamic Ultra-Harmonizer with a 95 second sampling board.



#### DSP4000 Ultra-Harmonizer

The Eventide DSP4000 Ultra-Harmonizer® takes digital effects creation and processing to a whole new level of excellence with a major leap in sheer processing power. It has digital as well as analog I/O; preset storage on removable memory cards, the largest LCD display and the easiest to use operator controls in the industry. Create unique, never-before-heard sounds and effects with the DSP4000's algorithm "building blocks." Using the DSP4000's Patch Editor, choose from over 90 effects modules and connect up to 40 in one preset for limitless creativity. Only the DSP4000 can build reverb presets with up to four pitch shifts for world class digital effects.

Specifications subject to change or revision.

## GENTNER

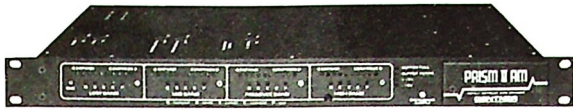

### Prism II AM Processing

The Gentner Prism II AM features variable asymmetry, a voice phase-rotator to assure maximum modulation, and a low-frequency tilt-corrector that can compensate for some weaknesses in plate-modulated transmitters. The heart of the Prism II AM is similar to its counterpart, the Gentner Audio Prism. This proven audio processor delivers the clean, powerful sound of digital control and individual gating of bands so record fades don't "swish up."

Standard configuration of the Prism II includes a rear-panel barrier-strip for audio connections, and is easy to maintain.

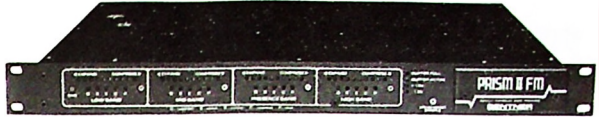

### Prism II FM Processing

The Gentner Prism II FM is a digitally controlled high-performance multi-band audio processor designed for major market broadcast use and other applications where aggressive, dominant sound is required. It utilizes four intelligent digitally-controlled processor cards to achieve high apparent loudness while producing few processing artifacts. This absence of undesirable subliminal listener aggravation reduces listener tune-out, producing higher quarter-hour ratings.



### Lazer FM Limiter/Stereo Generator

Gentner's Lazer is the cleanest sounding FM Limiter/Stereo Generator available. No longer do you have to feed your audio through an analog processing chain. Lazer handles audio purely in the digital domain to provide excellent aural specifications including maximum stereo separation, precise limiting and virtually no noise. The result: your audio retains its true sound. Front panel buttons and an LCD display menu allow you to numerically define pilot injection, release times, limiting threshold, and other operating parameters. Once the parameters are set, your worries are over. Lazer's adjustments will never drift. Precise values, along with preset programs, allow you to repeat settings exactly. An extensive range of operation parameters, clean manipulation of audio, precise stereo generation with minimal crosstalk, and simple operation let you produce the sound you want.

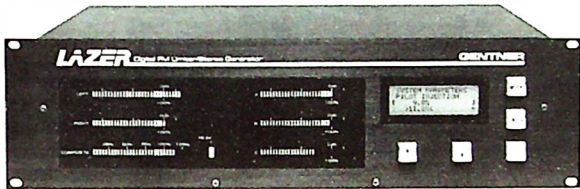

## INOVONICS



### 705 Stereo Generator

The 705 is a full-featured, stand-alone FM Stereo Generator incorporating necessary low-pass filtering and transmission preemphasis functions. The subcarrier and pilot signals are generated by *digital circuitry* to assure optimum performance and drift-free operation. Easy setup and maintenance. FMX™ System plug-in option.

### 715 David Audio Processor/Stereo Generator

The Inovonics 715 David is an integrated audio processor/stereo generator for all FM-stereo broadcasting applications. The comprehensive audio processing section combines the functions of a gated, gain-riding AGC with split-spectrum dynamic compression and peak control. The result is a signal which is both "competitive" and fully protected from overmodulation. The stereo generator section features digital synthesis of the composite signal with its inherent superior stability and performance. Internal combining for SCA or RDS subcarriers is provided, as well as a TTL-level 19kHz pilot output for subcarrier sync.

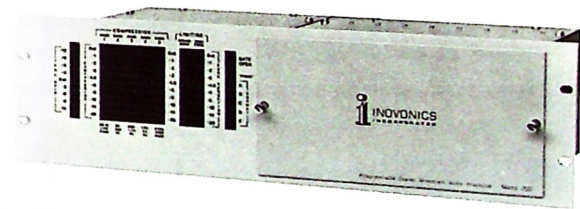

### 250 Stereo Audio Processor

Inovonics' 250 is a comprehensive multiband stereo digitally programmable audio processor for demanding applications in the AM, FM or TV broadcasting services. Programmability of the 250 enables the user to adapt processing parameters to alternative program sources or to suit changing station formats and listener profiles over the course of the broadcast day.

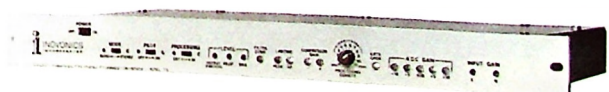

MODEL 715

LEXICON



**Alex Digital Effects Processor**

The new Alex Digital Effects Processor puts Lexicon's legendary digital reverb and effects processing in an affordable new package. It is a full rack device with a 2 character LED display and full remote control of program change and bypass via standard footswitches. Alex has 16 phenomenal presets, 3 adjustable parameters (providing Alex with over 4,000 effects combinations) plus another 16 user registers for storing your own unique sounds.

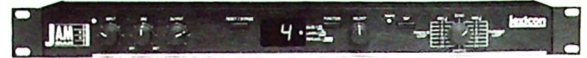

**JamMan Audio Effects Processor**

The JamMan Effects Processor from Lexicon presents a unique approach to using echoes, samples and loops. The echo mode has 8 seconds of memory and tap tempo for simple setting of echo time. Forward and reverse sample playback has an Audio Trigger making recording and playback a snap. Powerful looping device allows up to 8 loops to be created and selected with MIDI control. Create rich backgrounds and construct song ideas or layer sounds with JamMan.



LXP-1

**LXP-1 Multi-Effects Processor**

The Lexicon LXP-1 Multi-Effects Processing Module's 16 bit linear PCM A/D and D/A converters are extremely accurate, with wide dynamic range necessary for quiet reverb "tails" and crisp delay effects. It uses the latest VLSI technology; has 16 programs with all the sounds you need. The LXP-1 has 128 user registers to store your own personal settings. You store and recall registers using MIDI Program Change commands.

MODULATION SCIENCES



**CP-803 Composite Processor**

The CP-803 composite processor minimizes the distortion that conventional processors sometimes create. Conventional audio processors work with the left and right audio. But the CP-803 deals with the stereo composite signal that comes out of the stereo generator. By working on this signal instead of left and right audio, many audio problems are avoided. Rack mount included. Up to 2 dB more loudness.

ORBAN



**222A Spectral Enhancer**

The Orban 222A Spectral Enhancer improves the impact of your stereo broadcast by intelligently expanding the stereo image. Your listeners will notice an improvement in definition, clarity and depth. The 222A/U will not exaggerate multipath problems, nor will it degrade your mono signal. Works in harmony with your existing audio processing and offers an edge over your competition.

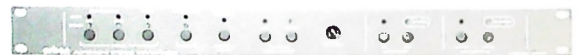

**275A Automatic Stereo Synthesizer**

The Orban 275A automatically detects if program material is mono or stereo. If mono, it synthesizes it into stereo, adding a very pleasing sense of ambiance and spaciousness. The 275A also senses and corrects out-of-phase (polarity reversed) and single-channel signals.



4000

**4000 Transmission Limiter**

The Orban 4000 is ideal for transparently protecting transmission links from overload. Available in single-channel and dual-channel configurations. The dual-channel unit can be operated in stereo or as two independent units. To achieve simple, error-free set-up and operation, the 4000 Transmission Limiter is configured with the minimum number of controls and indicators necessary. Unique, patented circuits and systems provide the most natural, uncolored sound available. For transmitter processing, consult information on the Optimod 8100A for FM or the 9100B for AM listed on pages 20 and 21 of this section.



# PURE PROGRESS.

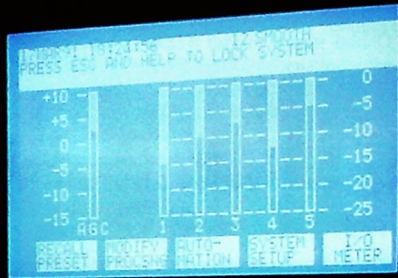

OPTIMOD ▶ FM

8200  
DIGITAL

POWER

## Stations Are Profiting From It.

FM stations around the world are finding more sophisticated ways to keep their listeners from cruising the dial. And OPTIMOD-FM 8200 has become a critical part of their strategy. Why? Because the 8200 is a technological breakthrough with direct impact on your station's profitability. It lets you create a distinct, powerful sound that results in larger audiences, higher ratings and improved profitability.

## Digital Makes the Best Even Better.

Digital signal processing not only improves the quality of the signal—it makes the OPTIMOD-FM 8200 more programmable, more flexible and more user-friendly. And it can actually help keep capital equipment costs down because it allows stations to expand and upgrade their system

with software, rather than expensive hardware.

A case in point: all current 8200 owners have received a new software upgrade free of charge. Version 1.0's sonic and operational improvements meet broadcasters' ongoing demands for superior audio performance and increased control—like customized bass response and automatic switching of presets for dayparting.

## The New Standard.

The OPTIMOD-FM 8200 is now the new industry standard for digital audio processors. Call your dealer now for a hands-on evaluation of the 8200. In a market where stations live and die by the ratings, you can dominate the dial.

**FEATURE-PACKED**  
**1.0 SOFTWARE**  
✓ Improved Sound  
✓ Greater Control  
**CUSTOMIZE Your Sound**

**OPTIMOD ▶ FM**  
D I G I T A L

**urban**®

© 1993 AKG Acoustics, Inc.  
Urban and OPTIMOD are registered trademarks of AKG Acoustics, Inc.  
AKG is a registered trademark of AKG Acoustics, Inc.

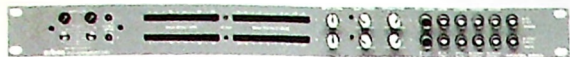

**464A Stereo Leveler/Limiter**

Orban's model 464A Co-Operator™ is a four stage, easy-to-use Gated Stereo Leveler/Compressor/HF Limiter/Peak Clipper in a powerful and economical dual-channel package. Front-panel pushbuttons let you configure the unit as a subtle, automatic gain-rider, as a transparent safety limiter, or both. Use it to assist you in recording and transferring audio and video tape, processing mic channels, or protecting broadcast cart machines, satellite uplinks, STL microwave links, or SCA's.



**787A Programmable Microphone Processor**

The Orban 787A Programmable Microphone Processor provides up to 99 user presets to optimize mic processing for each of your air-personalities. Excellent for control room and production studio, the 787 combines compression, noise-gating, equalization and sibilance control — all digitally programmable. Preset switching is remote controllable. The 787ASL adds a second channel. The 787ARC is a compact remote controller to install at your console to easily recall presets.



**OPTIMOD-FM 8100A1 FM Processing System**

The perennial OPTIMOD-FM 8100 adjusts your station's sound to suit your format and competitive situation. A built-in stereo generator provides an excellent quality stereo signal and maintains precise peak control. Stations using OPTIMOD-FM stand out with a competitively loud signal that attracts and holds listeners. 8100 optional enhancements include the XT2 Six-Band Limiter, ST Studio Chassis and 8100AFC Filter Card. The Orban 8100AST/U studio chassis accessory to OPTIMOD-FM provides level control *before* telephone lines or studio-to-transmitter link (STL) microwave, allowing maximum use of the STL's available dynamic range without overload.



**8100AXT2 Six-Band Limiter For OPTIMOD-FM**

The Orban 8100AXT2 six-band limiter accessory to OPTIMOD-FM is for those stations that want an even louder or more processed sound than that provided by the OPTIMOD-FM alone. Adding the XT2 can make your station much *louder* and *brighter*, yet still stay remarkably open. The XT2 adds punch and impact to bass, gives a dramatic sense of presence to the mid-range, and keeps the highs in perfect balance.

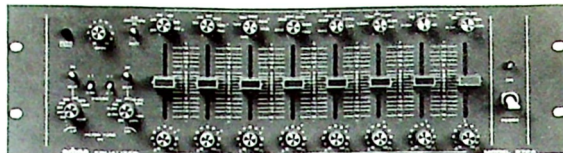

**672A Mono Graphic Parametric Equalizer**

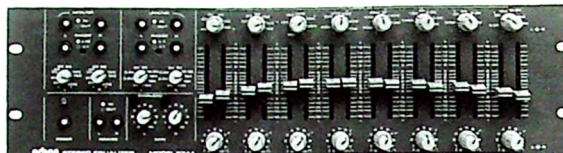

**674A Stereo Graphic Parametric Equalizer**

The Orban mono model 672A/U and stereo model 674A/U are cost effective, professional, quasi-parametric equalizers with the convenience of graphic type EQ controls. Wide range high and low pass filters with 12 dB/octave Butterworth slopes follow the graphic section for added versatility. Each feature has been thoughtfully chosen and cleverly implemented to make the equalizer a particularly powerful tool in nearly all areas of audio.



**OPTIMOD-FM 8200 Digital Audio Processor**

The OPTIMOD-FM 8200 Digital is a revolutionary breakthrough in FM processing utilizing digital (DSP) processing. It contains all of the necessary processing functions for competitive sound. The 8200 features a quick set-up, 26 factory and 32 user-programmable presets, automated switching of presets, multi-level passcode security and a digital EBS tone generator. The 8200's RAM-based Hadamard-Transform stereo generator/encoder offers more than 75dB separation and unmeasurably low noise and distortion. Unlike analog processors, the 8200 is ready for processing upgrades by simply changing the software. The 8200 allows more adjustment than previous OPTIMOD processors to achieve your own unique airtone. Changes are stored in nonvolatile memory and can be easily compared to previous settings. Help screens are available to guide you through the system. The 8200 improves on the successful OPTIMOD sound with better frequency control and openness, rock-solid stability and excellent specifications. The new industry-standard for FM processing worldwide.



**8200ST Studio Chassis**

The Orban 8200ST Studio Chassis is the perfect companion to OPTIMOD-FM 8200 DIGITAL and OPTIMOD-AM. It provides level, high frequency, and peak control ahead of left/right telephone lines and microwave STLs feeding OPTIMOD at the transmitter site, maximizing the available dynamic range of the system without overload. The unit combines AGC, compression, high-frequency limiting and absolute peak control.

## 9100B1 OPTIMOD-AM Processor

The Orban 9100B1 OPTIMOD-AM<sup>®</sup> can give your station FM-like audio on the AM band, with a sound that is both very loud and very clean. It includes compensation for less-than-perfect transmitters and antennas.

9100B1 - Mono  
9100B2 - Stereo



## RADIO SYSTEMS

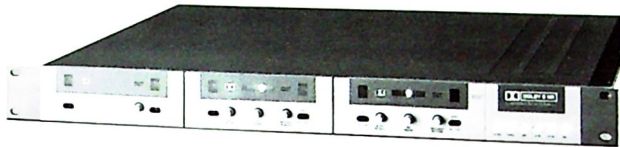

### RS<sup>2</sup> Noise Reduction System

RS<sup>2</sup> is the first broadcast product to incorporate Dolby S processing. It provides up to 24dB of noise reduction on carts, phone lines, discrete STL or RPU. The encode/decode system includes playback phase correction for up to 90 degrees of phase correction and it incorporates logic to recognize encoded carts, allowing intermixing of Dolby and non-Dolby cart libraries. The single-rack unit frame houses up to three stereo encode or decode cards and is also available in a phase correction only version.

## RANE



### GE 14 State Variable Graphic Equalizer

The GE 14 and GE 27 State Variable Equalizers bring a new standard of precision and control to the graphic equalizer format, through the development of unique Constant-Q bandpass filters. This important constant bandwidth feature means greater feedback control without compromising overall sound quality, less interaction between adjacent sliders from excessive filter overlap and a consistently high degree of resolution which allows significantly more effective equalization of actual complex room acoustics. Backed with outstanding specifications, high quality components and rugged steel construction, both the GE 14 and GE 27 provide a degree of accuracy, ease of operation and resultant sound quality that is simply unattainable with conventional graphic designs. The precision constant-Q performance of the GE 14 and the GE 27 give consistent resolution and the difference is clearly audible.

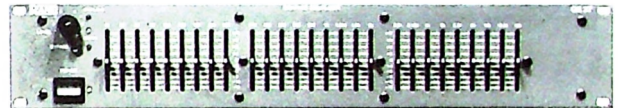

### GE 27 State Variable Graphic Equalizer

#### Specifications: GE 14 and GE 27

GE 14: (14)<sup>1</sup>/<sub>2</sub> octave state variable equalizers on ISO centers from 40Hz to 16kHz.  
GE 27: (27)<sup>1</sup>/<sub>2</sub> octave state variable equalizers on ISO centers from 40Hz to 16kHz.  
Sliders: 45mm full-throw, positive center-detent.  
Range Boost: 12dB (+2/-1dB); Cut 15dB (+2/-1dB).  
Signal/Noise Ratios are +4dBm (1.23V, 600 ohms), unweighted, 20kHz BW.  
Frequency Response: 31.5Hz to 27kHz, +0/-3dB.  
THD + Noise: less .009%, 20-20kHz with +4dBm output.  
Overload Indicator: Red LED, lights at 4dB below clipping.  
Size: 19"Wx3.5"Hx8.5" rack depth.  
Weight: GE 14 - 9 lbs. net; GE 27 - 8.5 lbs. net.

## ROLAND

### SN-550 Digital Noise Eliminator

The SN-550 is a dual-channel fully digital noise elimination system that employs exclusively designed DSP circuitry to remove all types of noise without changing the overall sound. The Noise Cancel section employs a unique multi-band downward expanding system. The Hum Cancel section enables AC line hum or buzz from CRT displays and dimmers to be isolated and removed. The SN-550 performs noise cancellation in real time, making it ideal for professional sound reinforcement and other applications.



*If the Audio Processing equipment you need is not listed in this section —  
Please call the Harris Allied broadcast experts.  
In the USA - 800-622-0022 - For Worldwide Contact Information See Pages B & C*



### 421 AGC-Leveler

The Symetrix 421 AGC-Leveler takes the place of a skilled human operator and works like a 'phantom hand' on the fader. The 421's Automatic Gain Control section incorporates a smooth-acting leveling amplifier working in conjunction with a make-up gain stage coupled to the ratio control. To deal with system noise, the 421 offers a full-featured downward expander section to quiet the output when input signal is absent. The 421's 'smart circuitry' (Activity Release Monitor) instantly distinguishes the difference between 'real' signals and noise and feedback. The 421 also provides a fast-acting limiter for fast set-up and accurate input/output monitoring.



### 501 Compressor/Limiter

Symetrix' two processor device with variable ratio compressor and an infinity-to-1 peak limiter for the ultimate in compression/limiting. "Soft knee" transition characteristic assures sonic integrity. Selectable automatic mode significantly reduces overshoot and distortion. Balanced and unbalanced inputs and outputs.



### 564E Quad Expander/Gate

The 564E Quad Expander/Gate helps develop a cleaner, tighter, smoother sound — whether in the studio or on concert tour. With four channels of powerful expansion and gating functions packed into a single space package, the 564E continues the Symetrix tradition of innovative design and operational flexibility plus solidly built to last. Using the 564E on tour, the sound engineer can quickly eliminate excessive drum ringing or cymbal splashing, because the 564E provides frequency-dependent control to eliminate spurious triggering from adjacent sounds. The 564E can also be used in a studio setting as a single-ended noise reduction system eliminating low level sounds without affecting the program material.



### 425 Dual Compressor/Limiter/Expander

In designing the 425 Dual Compressor/Limiter/Expander, Symetrix aimed for useable audio control. Symetrix developed a new approach to total level control, calling it Integrated Dynamics Processing (IDP). IDP makes all three processing modes available all the time. Plus IDP also means powerful, streamlined controls that make the 425 easy to learn and quick to set up. Compressor threshold, release and ratio, limiter threshold and overall output level let you respond to any audio situation fast and LED meters show what's going on inside each section. Maximize the quality of cart dubs, eliminate risk of digital distortion also keep phone lines clean and levels under control.

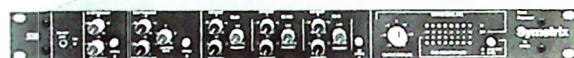

### 528 Microphone Processor

Complete microphone input signal processor: mic preamp, compressor/limiter, downward expander, parametric equalizer/notch filter, de-esser, all in single rack space package. Phantom powering for condenser mics, balanced line input for high level signals. LED metering indicates output level, gain reduction, de-esser activity.



### 601 Digital Voice Processor

The Symetrix 601 Digital Voice Processor is the unparalleled digital signal processor well-suited for a variety of recording, broadcast, live sound and post production applications. Acting as a 'bridge' from the analog to digital domain, the 601 accepts mic or line level analog signals, converts to digital (18 bits) and then performs 24 bit digital domain signal processing at a rate of over 50 million instructions per second (MIPS). The 601 works great on voice enhancement, working wonders on any signal. Processing includes fully parametric EQ, shelving EQ, notch filtering, dynamic filtering (noise reduction) de-essing, delay (first reflection), stereo synthesis, gating, expansion compression and AGC.

**Get the equipment you need now!  
Lease through Harris Allied.**

*Leasing makes more equipment available when you need it most.*

**For the total leasing picture please call  
In the USA 800-622-0022 - See Pages B & C for Worldwide Contact Information**

*Leasing and financing are available in most areas with approved credit.*

PRINTED IN USA ©1994 HARRIS CORPORATION

## UREI

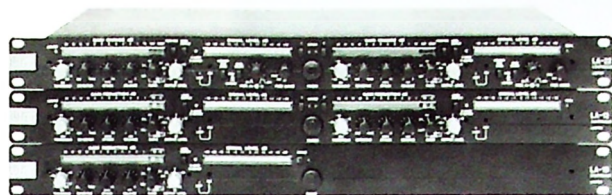

LA Series (Top to Bottom): LA-22, LA-12, LA-10

### LA Series Compressor/Limiters

The LA Series from UREI consists of LA-22 Dual Channel Frequency Selective Compressor/Limiter/Expander with parametric filters, LA-12 Dual Channel Compressor/Limiter and LA-10 Single Channel Compressor/Limiter. The three LA Series models all share identical performance characteristics and differ only in terms of number of channels and features. Housed in a compact 1U rack space chassis, LA Series Compressor/Limiters feature three separate gain reduction circuits: Peak, Average and Peak Output Ceiling limiting. Front panel controls allow total command over Threshold, Detector mode, Attack, Release, Ratio and Output Level. When rotated completely counter-clockwise, the Ratio control activates an "Auto"

function which sets the Compression Ratio and Peak/Average to factory preset values for quick set up. Two high visibility LED displays provide visual indication of Input/Output levels and Gain Reduction. The LA Series was developed to meet the needs of today's audio professional and is ideal for the most demanding applications, including all levels of recording, broadcast, installed sound and sound reinforcement.

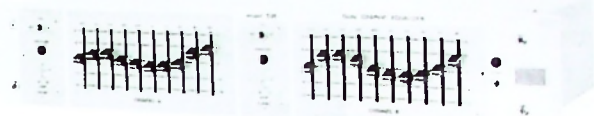

### 535 Dual Graphic Equalizer

The 535 Dual Graphic Equalizer has 10 filter sections per channel, increased control range and more output capability. Giving 12dB of boost or cut at each of 10 frequencies, which are centered at ISO one-octave increments from 31.5Hz to 16kHz, with balanced bridging differential amplifier inputs, variable gain, floating transformer isolated output of 150 ohms or greater load. Rack-mountable.

## VALLEY AUDIO

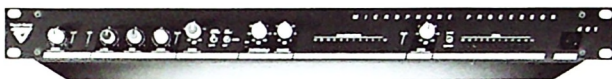

### 401 Mic Processor

Valley Audio Model 401 Mic Processor, Model 400 next-generation, is a combination Mic Preamp, Compressor, Equalizer, Expander/Gate, Sibilance Controller and Line Driver. Features include: built-in mic phantom powering, insert looping, preamp line outputs, low-noise, wide dynamic range mic preamp circuitry, 3-band equalizer and more. Also available through Harris Allied is Valley Audio's **Model 730 Digital Dynamics Processor** which bridges the gap between analog and modern digital audio in ways never before realized. Call today.



### 433 Dynamite<sup>3</sup> Dual Channel Compressor

The Model 433 Dynamite<sup>3</sup> is a dual channel, full-function Compressor, Limiter and Expander/Gate/Ducker, with enhanced stereo linking. Features include: selectable key or normal detector inputs, function-interactive dynamics control, low distortion and superior noise measurements and more. Also call Harris Allied for information on Valley Audio's **Model 460 X-Gate/NR** a full-function dual channel sweep frequency Expander/Gate with integral single-ended Noise Reduction, for audio and project studio production applications.

## YAMAHA

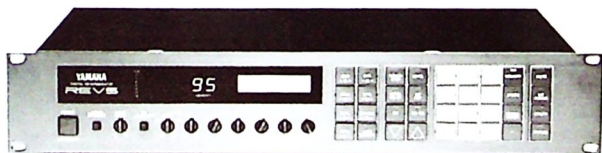

### REV5 Digital Reverberator

The Yamaha REV5 Digital Reverberator is unmatched in control versatility for truly creative effect applications. A third generation product, the REV5 gives unique reverb program parameters in delay, reverbtime, diffusion, reflection, density, space modulation, gate level, effect and much more.



### SPX1000 Professional Multi-effect Processor

The Yamaha SPX1000 Professional Multi-effect Processor is a sophisticated stereo digital signal processor offering a complete range of high-quality effects. Fully programmable, the SPX1000 features a 44.1 kHz sampling frequency, direct interfacing to digital equipment and everything for signal processing and effect on stage or in studio.

### SPX990 Professional Multi-effect Processor

Yamaha's SPX990 Professional Multi-effect Processor offers signal-processing, 20-bit A/D and D/A conversion, versatile three-stage effect configuration and a true stereo (2-in/2-out) configuration. It has 80 preset editable effect programs and 100 internal plug-in memory storage making effects portable.

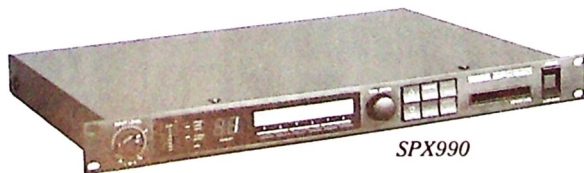

SPX990

Certain products not available in some areas.

**HARRIS ALLIED**

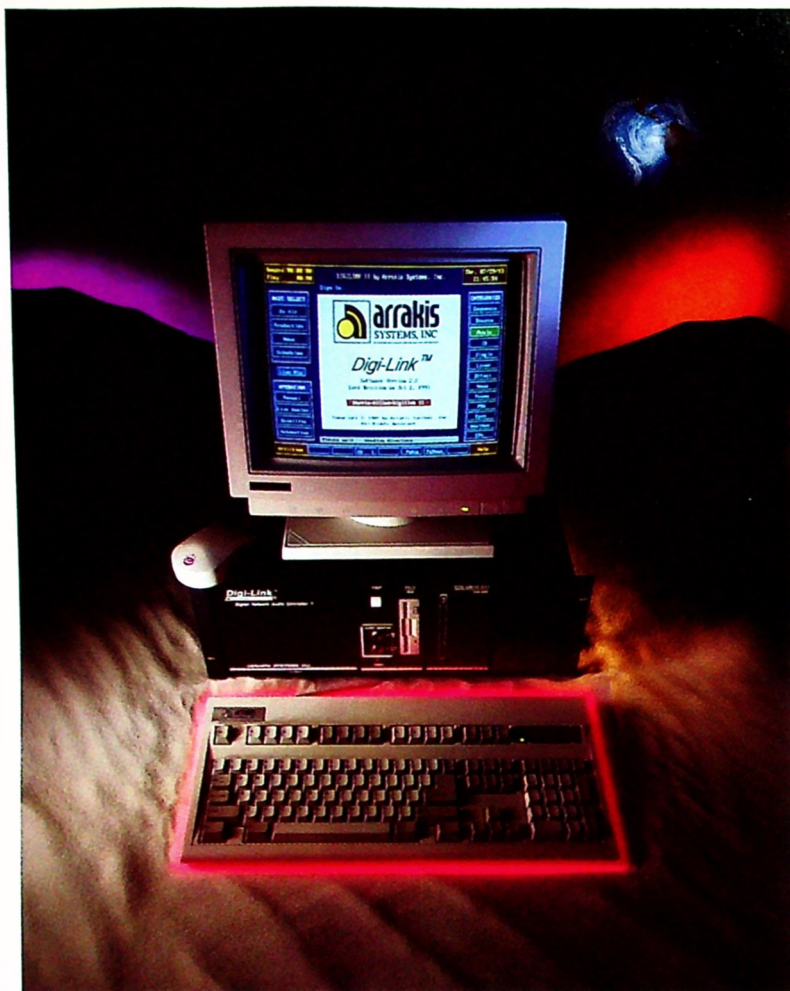

# Land The Profit Machine.

Land DigiLink by Arrakis. A digital workstation that boosts your station's profits by reducing maintenance and staffing demands. Out of this world sound and flexibility.

DigiLink is the perfect replacement for magnetic tape-based reel machines. Cue virtually instantaneously. DigiLink is the perfect audio record and play system for professional radio broadcast applications. And, it

costs less than comparable analog cart or reel machines.

DigiLink now supports overlap and crossfade of HD audio files that dramatically improves on-air sound, allows true HD automation and eliminates the need to edit the majority of files to adjust run times.

For fast and easy walk-away, let DigiLink automatically select and schedule your music. Simply schedule

or import your traffic and DigiLink does the rest.

With DigiLink you can double the number of user-definable clocks to handle the most demanding formats. And, the maximum number of satellite and live DJs has been increased to 40.

DigiLink also allows imported traffic schedules to include spots not yet produced and will automatically replace with a PSA if

the spot is not produced to air time.

DigiLink does all of this plus a whole lot more. Call us toll-free for complete details. Boost your station's profits while improving your production and on-air sound.



## Digilink Digital Studio System

### A Complete Digital Audio Radio Station

Digilink is a family of digital products for radio broadcast that provides a single integrated approach to the digital radio station of today and tomorrow. It is centered in an advanced user interface and hardware package. It is designed to replace cassette recorders, cart machines, cart carousels, reel to reel decks, and any other tape based audio recorder-player in a radio studio. It brings together the quality of CD digital recording, the flexibility of computer control, and the maintenance free nature of digital storage to create the ultimate audio record-play environment for radio. The simple and yet advanced video display may be controlled by keyboard, mouse, trackball, or even touch video screen.

### Production, Manual, Live Assist, Satellite Automation, and Automation Mode

In the Stereo Production Mode, Digilink emulates an analogue recorder with user friendly standard tape controls such as Record, Rewind, Play, Fast F, Stop and Cue. This mode also combines the best of digital production with noise free multiple recordings. Digilink will even automatically begin recording when audio starts for tight production. 'Graphical Waveform Editing' of the audio for cut and splice production applications is much faster and easier to use than reel to reel machines. The fast, intuitive, Digilink audio production mode brings true CD quality recording to the radio studio.

In the Manual Mode, Digilink is simply used as an analogue cart machine replacement. It does this 'Manually' as a build while you play sequence. In the Live Assist Mode, the audio sequences are preprogrammed. All your commercials, station ID's, magic calls, etc. can be preprogrammed and automatically brought up while live on air. Even though preprogrammed, the sequence can still be modified before or during play.

In the Satellite Automation Mode, Digilink replaces the entire standard complement of cart machines, carousels, reel to reel machines, switchers, and controllers. Digilink contains the entire commercial library plus liners, ID's, jingles, promos, PSA's, sound effects, weather, news, or any other audio file that you may want. Digilink reduces hardware expense while improving sound, simplifying operation, and reducing maintenance. With Digilink up to 7 days of walk away schedules may be created which automatically adjust for jock schedules and Network stopsets. With automatic error checking of inputted schedules, and past kill date commercials, Digilink dramatically improves the quality of satellite formatted radio station audio.



Printed logs from Digilink will automatically track actual ON AIR play of commercials and network errors. With it's capacity to be easily changed at any time, even during playback, Digilink is the perfect solution for satellite automation systems.

In the Automation Mode, Digilink can be a full automation system with unmatched flexibility. In this mode, Digilink may contain the complete commercial library and thousands of songs in instant access hard disk storage. Another alternative is where Digilink controls multiplay CD machines for the music while the hard disk supplies the commercials, ID's, liners, promo's, etc.

### SPECIFICATIONS

#### Digital Record-play System

*Frequency Response:*  $\pm 5$ dB 10 Hz-20kHz

*Dynamic Range:* >85dB

*Distortion - Total Harmonic:* .008%  
(+0dBV in-out, 30kHz filter)

*Sampling:* 16 bit linear PCM

*Sampling Rates:* 44, 32, 16kHz

*Compression Type:* adaptive differential PCM

*Compression Ratios:* 1:1, 2:1, 4:1

*System Processor:* 80286

*Memory:* 1MB RAM

*System Hard disk:* 40MB

#### *Impedances:*

Line In: >10,000 ohms, balance

Output: <100 ohms, balanced

Output Level: +24 dBm max

*Earphone:* +24dBV into HI-Z

*Dimensions:* Digilink Two

10"Wx17"Dx3RU; Weight: 80 lbs.

*Power:* 110/220 VAC, 50/60Hz, 300W

### DIGILINK FEATURES

- ▶ Full CD quality
- ▶ Record and play at the same time
- ▶ Control multiplay CD machines
- ▶ Use digital Networks to link systems
- ▶ Use 3rd party traffic, billing, and music
- ▶ Digital Waveform Editing Production
- ▶ Multiple compression ratios- 1:1, 2:1, 4:1
- ▶ Handle mono and stereo files
- ▶ Random access- instant cueing
- ▶ No maintenance- 15 year average life
- ▶ Cross fade & overlap of hard disc audio files
- ▶ Autofill & smart-squeeze
- ▶ Auto music scheduling
- ▶ International languages & user definable screen support
- ▶ Cart rotation
- ▶ Macros w/function key assignment



DHK's AUDISK is available exclusively from Harris Allied



**HARRIS  
ALLIED**



## AUDISK — Audio Storage/ Retrieval System

AUDISK is a software/hardware system that directly replaces carts, cart decks, production cart recorders, commercial playback equipment, dedicated recorders, audio switcher, logger and controller with one self-contained integrated unit.

AUDISK is an audio storage device designed specifically for the broadcasting environment, featuring professional quality, superior performance and ease of use. It combines a digital controller, high capacity hard disks, and audio and control input and output components in a single, compact 8.75-inch high, rack-mountable chassis.

In the basic DS-1000 system configuration, the supplied hard disk will store approximately 360 minutes of stereo, 15 kHz digital audio. With today's hard drives, AUDISK has a limitless maximum capacity of instantly-accessible on-line audio. Systems configured for 10 kHz bandwidth further extend the storage time.

AUDISK stores whatever is put into it— commercials, PSA, promos, music, programs, network news, jingles, sound effects, etc. — as "soundfiles" in pre-designated numbered slots. Once recorded, any soundfile can be played back instantly, either by using AUDISK's keyboard or by a closure on any of sixteen dedicated remote start lines. These remote starts, along with "end of message" (EOM) outputs, enable AUDISK to be used with automation systems, for live-assist or as complete satellite format automation systems.

AUDISK is used around the world for satellite uplinks, satellite downlink, automation, and cart machine replacement.

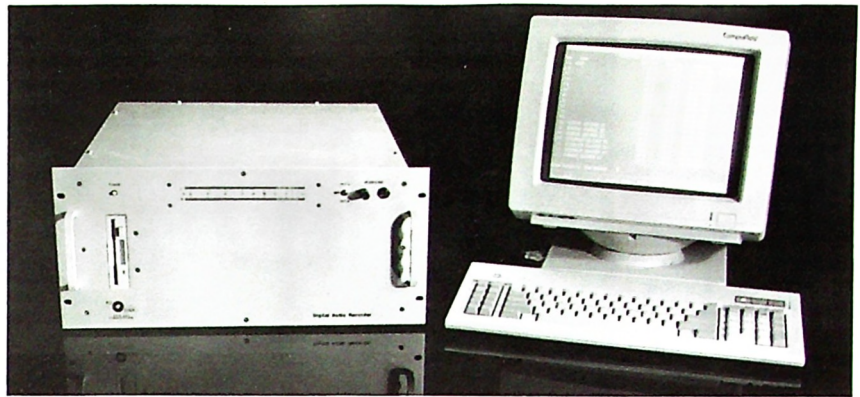

### General features

AUDISK's efficient storage format, instant access, wide frequency response, and industry-standard audio inputs, outputs and controls are optimized for direct replacement of broadcast cart machines. Carousels™ and Instacarts™ But with built-in automation, digital quality, very low maintenance, automatic commercial logging and perfect timing, AUDISK is *better!*

AUDISK can *simultaneously RECORD and PLAYBACK* audio files, even the SAME FILE at the SAME TIME. This makes AUDISK unique. No other form of audio storage can do this. Unlike cart machines, the same unit is used for both production and playback-to-air. There is nothing else to buy.

### AUDISK fits in!

AUDISK has been designed to fit into existing broadcast facilities, yet its direct digital I/O (inputs and outputs) provide a built-in path to the all-digital studios of the future. For control, all that's needed to start AUDISK is a standard contact closure, just like present cart machines use. The keyboard or serial data port can also be used to control AUDISK.

The system unit is only 8.75 inches high, so it *literally* fits in almost anywhere. A keyboard and monitor are provided for entering logs, for production recording and playback, and for making schedule changes during live-assist periods.

### AUDISK saves time

Features like instant playback, start-recording-on-audio, and Check End (instantly plays the first and last few seconds of a recording, for fast verification) put fun *and* efficiency into production tasks.

With all spots instantly accessible for on-air playback, commercial scheduling becomes a breeze, since there is no need for complex juggling between multiple playback

devices as with Carousels. Typically, an entire weekend of commercial stopsets can be manually scheduled in less than 15 minutes. With the optional traffic system interface, even this simple task can be eliminated.

### Superb reliability saves labor

Other than an occasional dusting, AUDISK requires *no maintenance*. This is a tremendous labor savings compared to cart systems. AUDISK eliminates the need for head and capstan cleaning, replacement, and alignment; cart handling, repair, rewinding and replacement; and all mechanical maintenance.

The DS2002 allows running two complete separate formats out of the same unit.



## SYSTEM OPTIONS

### Disk Mirroring — A Recommended Option

A second disk containing data identical to the main hard disk is added to the system for redundancy.

### Redundant System Units

Two identical AUDISK systems are installed and connected with a high-speed network. Should either system fail, the other system can take over, handling both production *and* on-air tasks simultaneously.

### Traffic System Interface

With an optional software driver, AUDISK will interface with virtually any traffic and billing system that is IBM-PC or ASCII compatible.

**One AUDISK system can  
serve as:**

**Commercial playback source  
Infinite network news delay  
ID source**

**Jingle, liner source**

**Weather source**

**Time announcer**

**Complete production system**

**Scheduling system**

**Free-standing live-assist system**

**Studio 3-D cart replacement**

**Satellite network automation**

**Local news insertion system**



# Touch & Go.

The ENCO DAD486x Digital Audio Delivery System is a true cart machine replacement. With a touch screen, it really performs at your fingertips.

This system was planned for use in the real world. DAD's graphic user interface emulates a standard analog audio cartridge machine's con-



trols. Push PLAY and DAD plays the cut shown in the Playback "slot." The number of playlists you can store in DAD's memory is unlimited. And its powerful ARRAY feature puts 144 audio events at your fingertips for instant playback. ARRAY buttons are especially useful for sound effects, jingles, liners, intros, promos,

music beds and other effects. These selections can be of any type or length to further increase DAD's flexibility and ease of use.

Because the DAD system is designed for use on a standard 486 PC platform, you can choose to purchase a complete system or select your own hardware



platform and let ENCO provide the DAD486x software. Add the friendliest digital audio delivery system to your station. Simply touch & go... with DAD from Harris

Allied. Call for your free demo tape.

**1-800-622-0022**  
**Fax 317-966-0623**

 **HARRIS**  
**ALLIED**

## DAD486X Digital Audio Delivery System



**The DAD486x will do more than just improve your audio, it will improve your bottom line.**

The DAD486x Digital Audio Delivery System is an exceptionally high quality, digital audio production, recording and playback system. The DAD486x is designed to streamline and simplify the tasks of producing, recording and distributing audio in broadcast, and other applications where it is important to have ready access to a large audio library. The DAD486x eliminates the expense of operating and maintaining traditional, endless-loop cartridge machines while providing power, versatility and flexibility.

### Instant Productivity

Your DAD system will be almost instantly productive because of DAD's unique man machine interface. The DAD486x touch screen control emulates the simple and familiar format of standard audio cartridge machines to help minimize training time and eliminate operational errors. DAD's advanced production and operating features are so intuitive and easy to use and understand that your system investment will begin to pay for itself as soon as it is installed. You can immediately look forward to improved audio quality, reduced maintenance and down time, enhanced capabilities and operating ease.

### Live Assist and Automation Capabilities

The DAD486x can be automated to any level from simple live assist to totally unattended operation. Optional interfaces allow the DAD486x to work with all popular traffic and billing systems, control CD jukeboxes, perform satellite recording and handle audio routing and switching duties. The DAD486x has standard General Purpose Interface inputs and outputs which can be used to control many other manual tasks.

### Designed to Meet Your Needs

A DAD486x system can be configured to precisely match your budget and operational needs. The DAD486x is expandable. You can start with a single channel DAD system and add additional channels and work stations as your needs grow. Your DAD486x system can expand to a multiple

user, multiple channel system to allow simultaneous production, recording, and playback so your facility can operate at maximum efficiency.

### Unique System Flexibility

The DAD486x is designed for use on a standard 486 PC computer platform. ENCO's unique policy lets you choose purchasing a complete system including hardware and software. Or, if you prefer, you can procure your own hardware platform and ENCO will provide DAD486x software. This can be an extremely economical way to put DAD's many benefits to work for you.

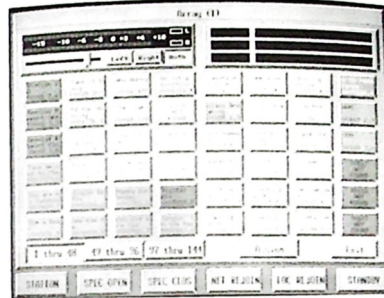

**The DAD486x ARRAY gives you instant access to 144 audio cuts.**

### Powerful Operating Features

The DAD486x was designed for use in the real world. DAD's graphic user interface emulates a standard analog audio cartridge machine's controls. Push PLAY and DAD plays the cut shown in the Playback "slot." An unlimited number of playlists can be constructed and stored in DAD's memory. Playlists can be manual, automatic, or mixed to let you operate your facility your way.

### Powerful Editing Capability

The DAD486x also extends operating ease to production and editing. Its graphic waveform editing lets you hear and see the results of head/tail trimming, cue tone placement, cuts and pastes, and segue fade points.

### Superb Technical Performance

The DAD486x system is built on a PCAT (80486) platform and stores digitized audio on it's internal or network hard drive. Each uses premium grade, "off-the-shelf" computer hardware to insure maximum performance, reliability and maintainability. The DAD486x is capable of utilizing multiple hard disks allowing you virtually unlimited storage. Coupled with Dolby AC-2, and Musicam compression, and user selectable digital sampling rates, your DAD system can manage, store and distribute as much audio as you require.

## DAD486x Technical Specifications

### Analog Inputs

Type: Unbalanced coaxial, 20 K $\Omega$  input  
Level: -10 dBV fixed  
Connector: RCA phono jack, gold plated  
Type: Active balanced, 20 K $\Omega$  min input  
Level: -8 to +18 dBu (specify with order)  
Connector: Standard XLR or DB9 (opt. dep.)

### Analog Outputs

Type: Unbalanced coaxial, 470 $\Omega$  output load > 10 K $\Omega$   
Level: -10dBV into 10 K $\Omega$  (fixed)  
Connector: RCA phono jack, gold plated  
Type: Active balanced, 20  $\Omega$  output load > 600 $\Omega$   
Level: -8 to +18 dBu into 600 $\Omega$   
Connector: Standard XLR or DB9 (opt. dep.)  
Type: Stereo Headphone, 8 $\Omega$  output  
Level: 0.5 VRMS (30mW) max into 8 $\Omega$   
Connector: 1/4 inch stereo phone jack

### Audio Performance (balanced I/O @ +4 dBu)

Analog Headroom: 20dB  
Digital Headroom: 16 dB @ "0" VU  
Frequency Response: 30 Hz - 20 KHz,  $\pm$ 0.1 dB  
THD: < 0.02%  
IMD: < 0.01%  
Dynamic Range: > 92 dB  
SNR: 70 dB (typical)  
Stereo Separation: 70 dB (typical)  
IC phase error: < 0.5 degree @ 15 KHz  
IC amplitude error: < 0.05 dB  
Common Mode Rejection Ratio: > 80 dB

### Physical Dimensions

19"W x 20"D x 7"H  
483mm x 508mm x 178mm  
33 lbs (15Kg)

### Digital Signal Processing

Signal Processor: Texas Instruments TMS320C51 / TMS320C3 I  
Sampling System: 16 bit linear PCM, Sigma-Delta conversion  
Input Filtering: 64x Oversampling (digital)  
Output Filtering: 8x Oversampling (digital) and 25 KHz 3 pole Butterworth (analog)  
Sample Rates: 32, 44.1, 48 KHz fixed, 6.5-50 KHz user selectable  
Data Compression: Dolby AC-2, Musicam, CDI-b, CDI-c, ADPCM, ADPCME

### Control System

Processor Type: Intel 80486DX, 50 Mhz  
Bus: EISA  
Operating System: MS-DOS 5.0  
Cache Memory: 64Kb, 25nx SRAM  
System Memory: 16.0 Mb, 60-70ns DRAM  
Storage: 660Mb, 1.2Gb, 1.8Gb, 2.4Gb, 3.0Gb standard SCSI-2 11 ms hard disks (daisy-chainable)  
Storage Capacities: approx. 60 minutes stereo audio per 100MB @ 6:1 compression and 48KHz  
Graphics Output: 14-20" SVGA monitors 1.0Mb 640x480 (256 color) adapter  
Input Devices: high-res resistive matrix touchscreen, keyboard, serial mouse and trackball  
Control I/O: opto-isolated inputs relay contact outputs TTL i/o  
Serial I/O: remote system control via RS-232/422 "D" connector  
Network I/O: 10 or 100 Mbps Ethernet  
Power: 110/220 VAC, 50/60 Hz 300 Watts (UL Approved)

## BELAR

### AS-1 Audio Sentry

The Belar AS-1 Audio Sentry is an alarm which aurally and visually alerts station personnel of the absence of modulation or carrier. The AS-1 will react immediately upon loss of carrier. In the case

of loss of modulation, the Audio Sentry can be programmed to sound off anywhere between 3 and 60 seconds. In addition to use in AM, FM or TV facilities, it may also be installed in locations with storecasting and public address systems as well as in recording and duplicating studios. (No picture available.)

## CONEX



### CG-25A Tone Generator

The Conex CG-25A Hz tone generator has built-in high pass filters for both the left and right channels, front panel LED indication of tone duration, silence and maximum length of untimed tone. All timing intervals, tone lengths and audio levels are easily adjustable from the rear panel. Standard six-pin "Cinch Jones" type connectors are provided for simple connection between the console and the recorder.



### CS-25 Dual Tone Sensor

The Conex CS-25 B-10 dual 25 Hz tone sensor is a compact and reliable bridging-type for use in broadcast automation and tape control systems. Front panel stop-delay adjustment accommodates any tape format. Indicator lights on the front panel indicate presence of tone. Front panel disable switches inhibit the relays allowing the tape to run without stopping at tones or signalling of the automation system.

CS-25 B-10 and CS-25 B-11 (with stereo high pass filter) are also available through Harris Allied.

## GENTNER



### Silence Sensor

The Silence Sensor monitors your audio source, observing both rising and falling edges of audio. If it notes a loss of audio or "silence," an open collector output is activated and the time-out sequence begins. If audio returns before time-out, the unit reverts to a "ready" state. However, if audio does not return after a programmed delay time, a second open collector output is activated along with a relay

closure. These outputs can be used to turn on lights, sound alarms or start other sources.

Time-out activation is programmable. A set of dip switches located behind a front panel insert allows you to set time-out for 1 to 165 seconds or 1 to 165 minutes. With this flexibility, the Silence Sensor can be used to monitor virtually any audio source. Silence Sensor's unique design ignores pops and clicks during the silence period and will not revert to a "ready" mode until true audio is returned.

## MUELLER



### T25-35SA Subaudible Tone Decoder

Automate your programming with a Subaudible Tone Decoder. The T25-35SA includes the subaudible tone detector, power supply and

decoding circuits in an aluminum enclosure. It operates from 120 volts AC and is entirely self-contained. It works with any network using 25 and 35 Hz tones for cue signals.

The T25-35SA will detect both 25 and 35 Hz subaudible tones and provides a 250 millisecond pulse via normally-open relay contacts for the three possible tone combinations: 25 Hz alone, 35 Hz alone, and 25 & 35 Hz together. These signals are delayed for about 300 milliseconds, at which time they are latched and output.

## SENTRY SYSTEMS



### Air Sentry II

The Air Sentry II is designed to constantly monitor the presence of an audio signal and to energize a relay when the audio is absent. Activation of the relay is front panel adjustable from 4 to 20 seconds. The relay may in turn be used to monitor any stereo or mono audio source such as audio from an AM/FM tuner, TV receiver or modulation monitor. Air Sentry is built to broadcast standards of reliability. Quick and easy rear panel connections via "Molex" type connectors (mating ends supplied).

## AUDI-CORD



Dual Transport  
Record/Play



Record/Play



Play

### DL Series

Born of the heritage of the Audi-Cord A and E Series with thousands in service, the DL Series features 100% solid state design with high noise immunity CMOS logic. Extensively modular design with plug-in circuit cards, Audi-Cord's heavy duty deck and head mounts stay adjusted. The DL series is available in record/play and play-only versions. Dual transport record/play model also available in the DL series.

The DL Series includes the following: DL-PM, Mono Playback; DL-PS, Stereo Playback; DL-RM, Mono Record/Play; DL-RS, Stereo Record/Play; DL-DM, Mono Record/Play-Dual Transport; DL-DS, Stereo Record/Play-Dual Transport; optional rack shelf is available.

### Playbacks:

Replay lock-out and reminder to prevent accidental replay errors. Manual or automatic muting of output audio. Status indicator lamps show cue tones presence, both SEC and primary. Latched lamps verify both have been sensed. Automatic motor turn-off if selected conserves power and heat. Full +8dBm output ability with 12db of headroom. Slide back cover for cleaning. Remote control connections.

### Record/Plays:

Full view meters for accurate level monitoring. Bias and tone presence indicators. Automatic meter switching from record to replay. Recording shut-off with the end of SEC tone option is provided.

## BROADCAST ELECTRONICS

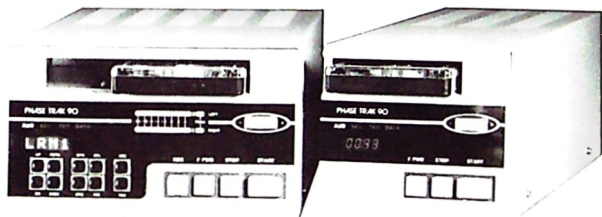

### Phase Trak 90™

If you are not satisfied with the audio quality of your carts, don't blame the tape. They only sound as good as your cart machines permit. Phase Trak 90™ cart machines guarantee you superior production and playback quality...no matter what brand of tape you use. A microprocessor-based Tape Analysis System "learns" and stores the optimal characteristics of 10 different tape formulations...assuring you of the highest production quality. Clean, crisp playback quality is assured with Phase Trak 90's exclusive Continuous, Non-encoded Electronic Phase Correction.

PT90APS, Play Stereo; PT90ARPS Record/Play Stereo.



### Dura Trak 90A

With the addition of its new, rugged direct-drive DC Servo Motor, BE engineers have made the Dura Trak 90A cart machine the simplest, most reliable and best-performing machine in its class. They designed it to eliminate on-air mistakes with Cart-not-cued and Cart-previously-played lockouts, automatic muting and auxiliary start pulse. Fast Forward and three tone cue sensing standard. Engineered for durability with 1/2" aluminum deck plate, gold-to-gold contacts, solid cast front panel. Simplicity, reliability, quality, affordability — Dura Trak 90A has them all.

DT90APS, Play Stereo; DT90ARPS, Record/Play Stereo.

## TAPECASTER

### 900 Series Cartridge Machine

The 900 Series is another Tapecaster first-class, top-quality cartridge machine. Easy-to-operate, a few of the 900 Series features include cartridge replay indicator, three cue tones with defeat function, fast forward manual or activated by secondary or tertiary tone, balanced bridging input and 600 ohm active balanced output.

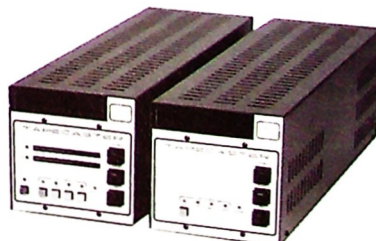

Certain products not available in some areas.

**HARRIS  
ALLIED**

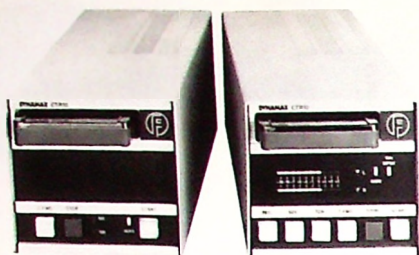

### CTR10 Series Cartridge Machine

The Dynamax CTR10 Series is Fidelipac's least expensive cartridge machine. But it is filled with the following features: fast forward (3x normal speed); secondary and tertiary cue tones; audio switcher and mixer; flashing cart played indicator; strappable repeat play disable; selectable high speed recue; all front panel switches illuminated; front panel 1 kHz defeat with dedicated indicator; versatile, switch-selectable audio/test metering; bar graph LED VU meters. Models: CTR12 Stereo Playback; CTR14 Stereo Record/Play; CTR11 Mono Playback; CTR13 Mono Record/Play.

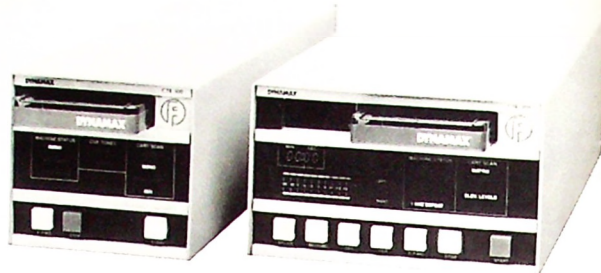

### CTR100 Series Cartridge Machine

The CTR100 Series offer features no other tape cartridge machine provides. Among the outstanding features the CTR100 offers are the exclusive CARTSCAN System which allows the operator to intermix cartridges recorded in various audio formats. The system also provides an auxiliary output to activate equipment such as a Dolby® encoder or decoder.

Contact us for details on all the different versions available.

## ITC



### Series 1 Audio Tape Cartridge Machine

ITC Series 1 cartridge machines combine quality, features, performance and affordability. These machines are designed to help you meet the changing financial requirements of today's broadcast environment. Series 1 cartridge machines are available in mono or stereo recorder or reproducer versions. Several newly designed features enable the Series 1 to provide such benefits as cool

operation, longer component life, less wow and flutter and improved tape stability.

The Series 1 from ITC is available as a 1/3 rack width stereophonic or monophonic reproducer or recorder/reproducer. Standard features include hi-speed cueing from the DC servo motor, three cue tones (1 kHz, 150 Hz; and 8 kHz) plus 1 kHz add/defeat, and superior ITC designed audio performance. Front panel LED indicators, metering and function select switches are also standard.

Cartridge stability is enhanced by a cast aluminum, nickel-plated deck assembly which is milled to precision tolerances and a new cart hold-down system which uses silent guide rails.

The front panel, deck assembly, and internal P.C. boards are all mounted in a single-piece chassis which slides out of the steel case for easy servicing. P.C. boards are mounted using gold edge connectors and a motherboard/daughterboard design. Full remote control capability is available on the simplified rear panel. A motor on/off switch is also provided.

The Series 1 playback-only machine is easily and inexpensively upgraded in the field to a recorder/reproducer.



### Series 2 Audio Tape Cartridge Machine

The ITC Series 2 Audio Tape Cartridge Machines are configured as Recorders or Reproducers, available in stereo or mono. Requiring minimum maintenance and providing reliable and continuous service. The Series 2 is specifically designed for low internal operating temperature, permitting the machines to be housed in a one-piece, unventilated outer case preventing contamination. Standard features include three cue tones, high speed recue and audio mute at EOM 1 kHz primary cue tone delete/looping functions.



### 99B Series Cartridge Recorders

Unique in the world of cartridge recorders is the 99B. Loaded with features, the 99B Series pleases even the most discriminating user. Central to the 99B is the unique and patented ELSA feature. ELSA preparation automatically erases the cartridge, locates the splice and aligns azimuth of the record head for maximum phase response performance. There's nothing else like it. Call us for all the different model configurations.

# COMMUNICATION KNOWS NO BOUNDARIES.

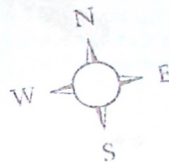

**B**roadcasting has literally changed the way our world sees and hears itself. Harris Allied has been behind those changes since 1922. As a leadership resource for broadcasters worldwide, our unswerving commitment to the industry is reflected in unsurpassed support and service as well as in engineering breakthroughs.

## Today, Harris Allied is:

- ⊕ an international manufacturer of radio and television equipment
- ⊕ broadcasting's RF technology leader with over 50 major innovations
- ⊕ the world's foremost single-source distributor of radio studio, production and satellite equipment
- ⊕ a worldwide planning and management resource for fully integrated broadcast systems, both mobile and fixed
- ⊕ a global leader in technical service, product support and personnel training

Broadcasters in more than 100 countries on six continents rely on us for innovative products, integrated systems and immediate service. We invite you to do the same. Contact Harris Allied today for more information.

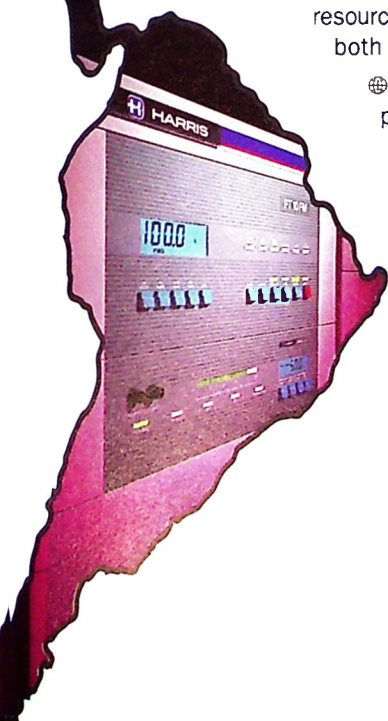
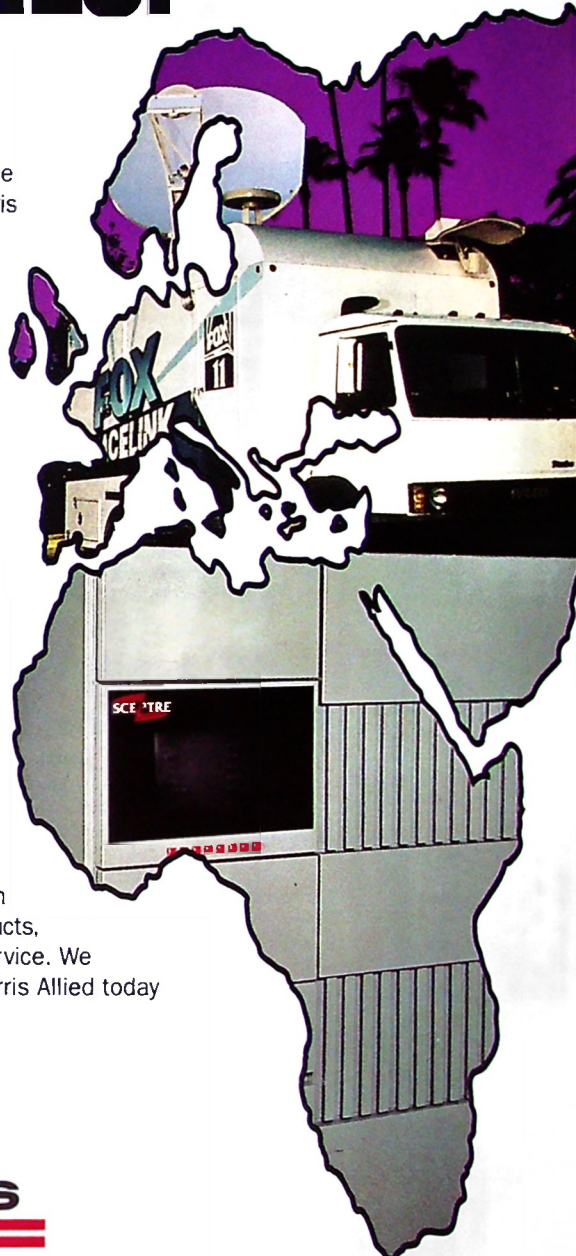

 **HARRIS  
ALLIED** 

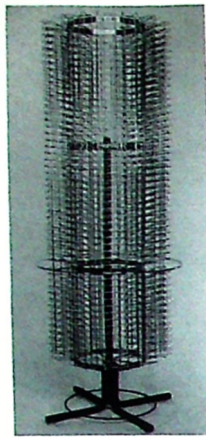

### Lazy Susan Cart Racks

Where strength and capacity are required at a minimal cost, the ABCO line of welded, durable wire lazy susan cart racks can fill the need. Available in a choice of 300 or 500 capacity, these industrial quality cart racks will give many years of dependable service. Hanging modules are available as separate units accommodating 50 carts, for wall hanging.

#### Lazy Susan Racks

Model	Cap.	Dimensions
ABOLS 300	300	6'H x 19"Dia.
ABOLS 500	500	6'H x 21"Dia.

NOTE: "Handle" ring diameter of ABOLS 300 is 22" and ABOLS 500 is 27"

#### Wall Rack

ABOLS 50	50	65 1/4"H x 4 1/2"W x 6"D
----------	----	--------------------------

## A-LINE

### Lazy Susan Series Cart Rack

Lazy susan cart racks are normally supplied with standard 4" base. However, any size base up to 30" is available. Special size racks are available. Laminates including walnut, pecan, oak or black are standard. Call, FAX, or write for prices on special bases, sizes or laminates.

Model	Cap.	H x W (in.)	Turn Radius	Net Wt. (lbs.)
A/L 100LS	100	33 3/8 x 10 3/8	14 1/4	45
A/L 160LS	160	27 7/8 x 14 1/2	20 1/2	65
A/L 240LS	240	27 7/8 x 18 7/8	26 3/4	120
A/L 400LS	400	33 3/8 x 23 1/4	32 3/4	225
A/L 800LS	800	60 3/4 x 23 1/4	32 3/4	335
A/L 1000LS	1000	60 3/4 x 27 3/8	39	402
A/L 1200LS	1200	71 3/8 x 27 3/8	39	450

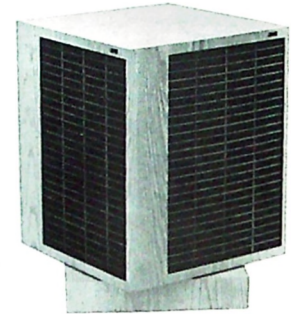

Lazy Susan Series  
N-Series  
Standard Free-Standing Series  
Audio Cartridge Storage  
from A-Line

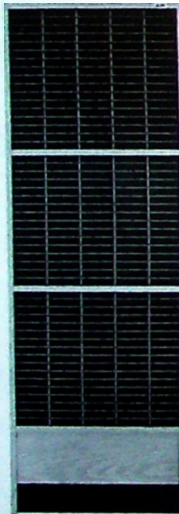

### Audio Cartridge Storage

For audio cartridge storage A-Line offers high-quality, highly flexible cart racks from the standard to the most customized lazy susan models. The Standard, Free-Standing units are designed for non-critical space situations. The "N" Series packs tremendous storage ability into a much narrower format when vertical space exists, but horizontal space does not. All cart racks are normally laminated in walnut, pecan, oak or black. Please specify. Special laminates and sizes are available. Call, Fax or write for special prices.

### N-Series Cart Rack

Model	Cap.	H x W (in.)	Net Wt. (lbs.)
A/L 100N	100	67 x 10	50
A/L 150N	150	67 x 14 3/8	60
A/L 200N	200	67 x 18 3/4	75
A/L 250N	250	67 x 23 3/8	110
A/L 300N	300	67 x 27 3/8	120

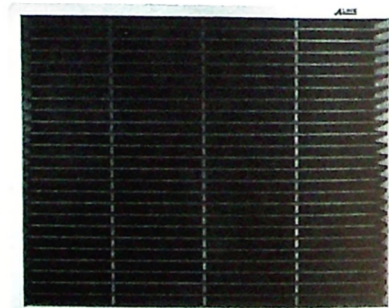

### Standard Free-Standing Series Cart Rack

Model	Cap.	H x W (in.)	Net Wt. (lbs.)
A/L 20	20	5 3/8 x 23 3/8	10
A/L 40	40	9 7/8 x 23 3/8	15
A/L 50	50	12 x 23 3/8	15
A/L 60	60	14 3/8 x 23 3/8	15
A/L 100A*	100	22 3/8 x 23 3/8	20
A/L 100B†	100	12 x 44 3/4	20
A/L 150	150	17 1/4 x 44 3/4	55
A/L 200	200	22 3/8 x 44 3/4	60

Additional capacities available upon request.

\* 5 wide, 20 high

† 10 wide, 10 high



## AUDIOLAB

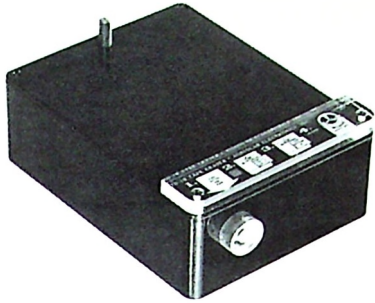

### TD-1B Bulk Eraser

The Audiolab tape degaussers with automatic overheat thermal protection erase audio tape, carts and cassettes. They erase up to 2" tape widths, accommodate up to 16" reels, provide a wide focused magnetic field to assure complete erasure and positive results every time with a simple operation. Dimensions: 3"H x 5 1/4"W x 7 1/4"D, shipping weight: 9 1/2 lbs.

TD-1B (117 VAC)  
TD-1BF (230 VAC)

## AUDIO-METRICS

### Premium Retrofit Card

The Premium Retrofit Card by Audio-Metrics is a direct retrofit to replace existing cards in the ITC® Premium Series cart play machines. Upgrade your faithful ITCs with technology of the 1990's. Direct plug-in — minimum modifications. Slew rate, rise time noise, distortion... all state-of-the-art. 0.06% THD, 0.01% IMD, 66 dB S/N.

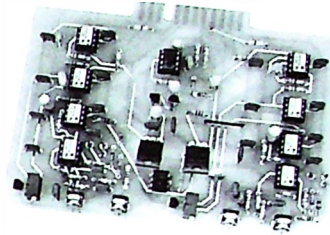

## AUDIOPAK

### A-2 Tape Cartridge

The AudioPak A-2 is the audio cartridge tape that has become a standard for broadcasters the world over. For stations who really care about how they sound, the A-2 is the logical answer to better sound.

### AA-4 Tape Cartridge

The key feature of the AudioPak AA-4 is the SGS-4 broadcast mastering tape. When recorded on a high quality cartridge recorder, the SGS-4 tape can produce virtually identical copies of the best analog or digital mastering tapes.

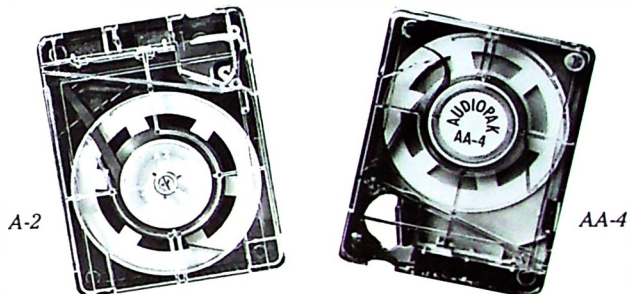

## BROADCAST ELECTRONICS



### ST-90 Bulk Eraser/Splice Finder

Broadcast Electronics' ST-90 makes proper cart preparation fast, easy and reliable! Running at 27.5 ips (23 ips at 50 Hz), it zips through your carts. Yet its dual erase heads thoroughly erase any NAB standard cart to a typical depth of 90 dB — uniformly and without adding noise of its own. After erasure, the ST-90's splice detector automatically positions the splice and stops the tape — it's virtually 100% accurate because it actually senses the thickness of the splice itself instead of using the less-reliable photocell method.

*We can Federal Express your order.  
Tell your Harris Allied Rep to "Fed X" it.*



*Certain products not available in some areas.*





### 300 Tape Cartridge

The Model 300 broadcast audio cartridge provides performance at a price that is within the budget of all radio and TV broadcasters. Its endurance under severe operating conditions in everyday studio operations is surprising, frequently lasting over five years with only replacement of worn tape and pressure pads. Not recommended for stereo.



### 400 Bulk Eraser

The model 400 features a removable guide pin, a scuff resistant top, a power-on indicator and wood case. It can erase all audio, video and computer tapes up to 1" wide and it has a thermal protected core that will not burn out.

400 (110 VAC)  
400-2 (220 VAC)



### Blank-It Bulk Eraser

If you need blank tape fast and are worried about recorder erase head wear, then worry no more. With the easy-to-handle "BLANK-IT" eraser from Fidelipac, you'll save time — no need to run the tape through your recorder. You'll save money — it allows instant reuse of the erased tape without worry about program residue or those mind destroying "whomps." "BLANK-IT" is hand-held for rapid, accurate tape erasing in any setting. Model 395.



### Dynamax Tape Cartridge

The Dynamax tape cartridge shell is constructed of high-grade engineering plastic for more strength, better heat stability and better dimensional accuracy. A modified internal tape path yields more accurate tape travel, less tape wear, lower scrape flutter and vastly enhanced phase uniformity. **Bulk tape available on 1800 ft., 7-inch reels. Standard tape also offered on 3600 ft., 10-inch NAB hubs.**

### ESD10 Bulk Eraser/Splice Finder

The Dynamax ESD10 gives you reliable splice detection and deep cart erasure, for flawless sound reproduction. It achieves an erase depth of 75 dB or more. Dual erase heads are used. A patented splice find system — the most reliable detector ever built, requires no sensitivity adjustments.



ESD10



### Fidelipac Cart Racks

The Fidelipac line of cart storage products gives you a choice of styles and sizes. These high quality racks will give you the storage space you need in a compact space.

- MR-200 Mobile rack holds 200 (includes casters)
- TR-48 tabletop rack holds 48
- TR-96 tabletop rack holds 96
- WR25 wall mount-25 carts



## Meat and Potatoes à la Fidelipac

**Cartridge Machines** – The Dynamax CTR10 Series combines solid value, superior audio quality and a highly reliable brushless DC servomotor. This machine needs no introduction with over 10,000 units installed in all four corners of the globe.

**Tape and Tape Cartridges** – Fidelipac continues to offer the industry's broadest selection of NAB tape cartridges including the DYNAMAX COBALT premium cartridge, the AUDIOMAX 4000 replacement for more expensive Type AA-4 cartridges, the MASTER CART and the MODEL 300, workhorse of the broadcast industry for thirty years. DYN-400X Professional Back Lubricated Recording Tape is also available on NAB hubs or 7 inch reels.

**Magnetic Erasers** – Fidelipac addresses every studio requirement with a choice of erasers, including the BLANK-IT hand-held eraser, the MODEL 400 table-top eraser and the DYNAMAX ESD10 cartridge eraser which also rapidly locates and positions the splice before recording.

**Other Accessories** include a wide variety of cartridge storage systems from a 25 slot vertical wall rack to a 200 slot mobile carousel, world standard studio warning lights available in eight different languages, and other useful accessories (not shown) including alignment cartridges and precision gauges for head insertion and right angle zenith calibration.



**DYNAMAX**<sup>®</sup>  
BROADCAST PRODUCTS BY FIDELIPAC<sup>®</sup>

## GARNER

### Dataraser 105 Bulk Eraser

The Dataraser 105 provides 100 percent erasure on all types of data reels, data cartridges and diskettes. Features include: complete erasure of 3480 cartridges, 10½ inch reels, floppy discs and other magnetic media; fast, reliable conveyor system; security key lock; automatic thermal cutoff; erasure level to -80 dB; two-year limited warranty. Other models from Garner are available from Harris Allied.

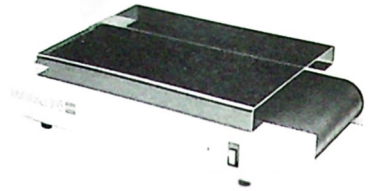

## HARRIS ALLIED

### Cart Labels

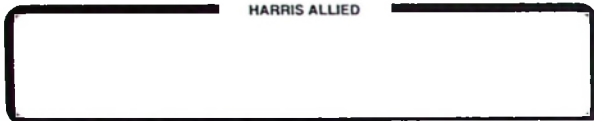

For labeling those all-important commercial, music and program audio cartridge tapes, these cart labels will stick. If label peeling is a problem, then you need a label from us! They stay when they should. They come off completely when they should. 12 labels per sheet. Pin drive. Several colors available. Sold only in increments of 10 sheets.

Actual size shown.

## ITC

### ITC-II Tape Cartridge

The ITC Cart II broadcast cartridge represents a breakthrough in technology beyond anything previously experienced in the industry. A revolutionary design eliminates pressure pads, utilizes a non-rotating hub and includes high-output, low-noise, lubricated tape for recording at high levels without performance loss. Tape and cartridge compliment each other like never before in the ITC Cart II broadcast cartridge.



## SIMPAC

### Simpac Cart Rack

For a cart rack that will mount anywhere and hold up to 10 carts, the Simpac line is just what the engineer ordered. Black only. Priced per module. Call Harris Allied today.

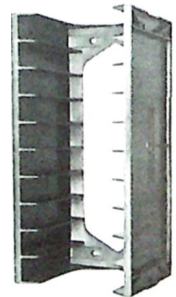

## SONAR RADIO



### VX-1401 Bulk Eraser

Sonar's VX-1401 provides economy and efficiency. The VX-1401 is simple to use and has full warranty. NAB cartridges and ¼ inch reel-to-reel tapes are thoroughly erased to noise-floor levels. 4½"Hx4¾"DIA, shipping weight: 4 pounds.

## TAPECASTER

### X-100 Cartridge Winder

The Tapecaster X-100 features state-of-the-art technology including two direct-drive motors and a floating aluminum tape supply disc which holds a 7" reel or 10½" pancake of lubricated tape. The solenoid brake stops the supply disc at the end of the wind. The X-100 has adjustable tension control for the supply disc brake, ramp design tape guides and four gold-contact rotary switches to program the wind to 7.5 ips. The wind time is accurately metered by the light copper and nylon counter wheel.

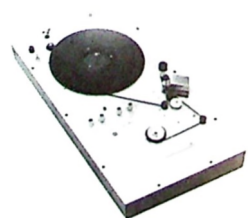

**DN-770R Bi-directional Output  
Cassette Recorder**

The Denon DN-770R was developed to meet the requirements of the nineties for DJs, musicians or sound installations. Features include: auto-reverse, relay recording, high speed dubbing, HX Pro™, and music search. Other conveniences allow you to playback two different cassettes at the same time, record simultaneously on both decks, automatically change decks for continuous audio, change key of a song during playback, memory rewind (return-to-zero) and many more high-quality, high-tech features.



MARANTZ

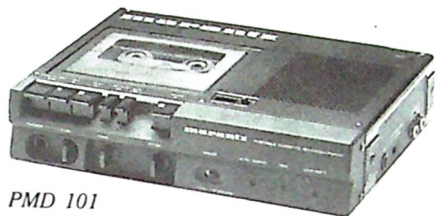

PMD 101

**PMD101 Portable Cassette Deck**

The Marantz PMD 101 portable cassette deck is the new value leader in portable cassette recording. The PMD 101 has all of the features a professional recorder should, including a built-in speaker, electret condenser microphone, normal or 1/2 speed operation with ±20% pitch control on playback, external mic input, line I/O, and more in a sturdy metal chassis. Dimensions: 2" x 9" x 6 1/2"; weight: 2.9 lbs.

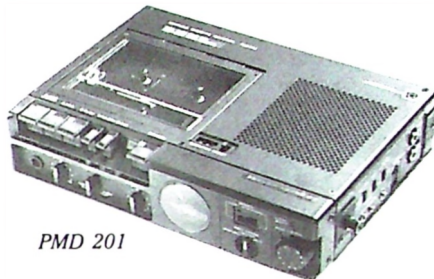

PMD 201



PMD 221

**PMD201 & 221 Portable Cassette Recorders**

The PMD 201 and PMD 221 by Marantz offer more to the broadcast news operation than ever before available. Outstanding features include: 15/16 ips (1/2 speed) or regular 1-7/8 ips, vari-speed control which allows correction of tapes which may have been recorded with less-than-full battery power, PA/Play mix permits one of the most sought-after abilities: live intro with optional microphone, actuality on tape, then back to live (using the cassette machine as an integral part of a telephone report).

In addition to features listed which are common to both machines, the 221 also has three heads and variable bias for normal, CrO<sub>2</sub>, and/FeCr tape. FeCr tape permits a frequency response of up to 14 kHz.



PMD 222

**PMD222 Portable Cassette Recorder**

The new PMD 222 cassette recorder/player is perfect for all critical recording situations. With built-in XLR connectors the PMD 222 has many more features including three heads, pause/play for live intro, modular phone jack and built-in speaker and microphone. The PMD 222 is destined to become the standard for the broadcast industry.

**PMD430 Portable Cassette Recorder**

The PMD 430 portable cassette recorder is for those who take live recording seriously. It provides professional-caliber location recording in stereo, featuring 3 heads, for true off-the-tape monitoring during the record process. The 3-head design optimizes head gap for each mode, resulting in high frequency performance. The PMD 430 also offers dbx noise reduction system which allows it to achieve a totally inaudible signal-to-noise ratio of 75 dB, for clear reproduction of low-level speech and music. Lightweight and impact resistant.



PMD 430

*Certain products not available in some areas.*



## MARANTAZ



### PMD 500 Dual Well Cassette Recorder

The Marantz PMD 500 gives the sound professional flexibility in a dual well cassette deck. Both wells record and play offering the option of either simultaneous or serial recording as well as continuous/relay playback. Both wells provide up to three hours of continuous recording. The PMD 500 is a part of the professional PMD series excellent for churches, schools, government and businesses as well as professional musicians.



### PMD 510 Dual Well Cassette Recorder

The Marantz PMD 510 offers extraordinary sound quality and reliability especially when applied in religious institutions and by DJs, dance and aerobics studios. The PMD 510 is a flexible dual well cassette deck where each well is a completely independent cassette deck with its own discrete set of stereo inputs and outputs, two motors, two heads, pitch control, stereo bargraph meters, real-time counters, Dolby B, C, and HX Pro, plus large, easy to operate keys.

## NAKAMICHI



### MR-1B Cassette Recorder

The Nakamichi MR-1B is a professional quality audio-cassette recorder well suited to broadcast applications. Housed in a standard 19-inch rack enclosure, the front panel measures 5 5/8 inches high, including the mounting feet. An advantage that this machine has over many others is its professional input/output capability. It provides both front panel 1/4-inch and back panel XLR-balanced connectors for +4 dBm levels. Back panel unbalanced input/output 1/4-inch connectors also are available.



### MR-2B Cassette Recorder

The Nakamichi MR-2B proves that it is possible to design a budget-priced professional deck with sound quality that stands above the crowd! If you need an affordable top-quality professional deck for broadcast use, look no further! The MR-2B has been created and improved on for you. It has the professional features you need, the sound quality you demand, and it's surprisingly affordable. RCA and 1/4 inch connectors in and out. A Henry Matchbox makes a fine companion.

## SONY

### TC-D5PROIII Portable Cassette Recorder

The Sony TC-D5PROIII features reliable mechanisms including a Disc-Drive Capstan-Servo tape transport with a coreless motor. XLR mic inputs, RCA line outputs. Approximately 5.5 hours of operation more than ever before, are possible with two "D" size alkaline batteries. The TC-D5PROIII can also be operated on DC 6V with the addition of an optional AC adaptor (AC-D468) The TC-D5PROIII employs Sony's F&F head for outstanding performance and long-term reliability. The Dolby "B" noise reduction system is incorporated. VU meter & peak level indicator.



## TASCAM



### 112 MkII Stereo Cassette Recorder

Tascam's model 112 MkII is a basic 2-head machine is 19 inch rack-mountable. Selectable front (1/4" phono jack) and rear (RCA-pin jack) input terminals. Independent left and right channel input level controls. The 112 MkII is a worthy contender in the competitive professional arena. The optional LA-112 to convert to balanced in/out.



### 122 MKIII Stereo Cassette Recorder

The 122 MKIII is the leader in Tascam's line-up of professional 1/4-track 2-channel stereo cassette machines. It offers extended durability and reliability to keep up with the tough, relentless pace of professional operation. It features an extremely high standard of audio reproduction quality.

audio~metrics®

## CD 10

Compact Disc Cartridge Machine

**It's an entire generation better!**

You'll find the CD 10 a friendly, likeable programming tool which will encourage you to take CDs direct-to-air.



Chair rollers, fingerprints, peanut butter, cowboy boots and hair haven't a chance when your CD is protected in a safety cartridge.

We knew we were onto an industry trend-setter when we introduced the concept at NAB, 1988. Since then, it's become a broadcast standard.



Label Never Disappears

Now, there's a compact disc machine offering unique features. The CD 10 leaps ahead with a faster linear tracking system and a heavy aluminum deck plate. Low heat generation and positive ventilation provide for a cooler-running machine and the vertically-slotted, plug-in cards permit easy access and service.



CD 10 Uses Your Cartridge

Design criteria for the CD 10 called for the latest, 3-beam optics which are easily accessible for cleaning. Superior phase characteristics were achieved by using 8 times oversampling and an FDNR analog filter. For convenience and better control, the remote port supplies a "ready" signal when a disc cartridge is inserted into the machine. When the cartridge is inserted, it does not disappear, label remains in full view. A jog shuttle wheel provides quick search and location, and search forward into the next track or reverse into last track.

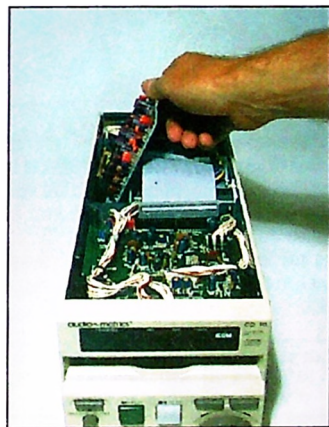

Plug-In Circuit Boards

With the CD 10's IECII, (DAT) output, dubbing to DAT is as easy as running a cable with appropriate connectors from the CD 10 to the DAT machine. Installing three units across is possible with one, optional, rack mount assembly.



Jog Shuttle for Quick Frame Search & Location

An innovative autolock will not permit an operator to accidentally pull the wrong cartridge. The CD 10 will not release a playing disc until the operator has made conscious effort to remove it. This feature ends the fear of embarrassment and dead air.

With the ability to recognize and respond to INDEX 3 subcodes used by several syndicators on CDs, the CD 10 can emulate automation in a manner similar to the secondary tone on a tape cartridge.

The CD 10 is a friendly, likeable programming tool which will encourage you to take compact discs direct-to-air. Call Harris Allied today for specific details on the Audio-Metrics CD 10.



Mount Three In Optional Rack Mount

DIGITAL



**DN-1200C CD Changer Controller**

This Denon controller is primarily for use with the Denon DN-1200F 200-CD Changer. However, universal remotes and other IR control systems can be programmed from the supplied remote, making it simple to integrate the DN-1200F system in any custom design. It features programmed playback of favorite program or category program, group mode, random playback (disc or track), index search and repeat playback of 6 variations.



**DN-2000F Compact Disc Player**

The Denon DN-2000F is a dual transport rack mount CD player with a wired remote control. The remote control features dedicated controls for each CD drive. When the play button is pressed, audio starts instantly. No delay and no lag. The long stroke sliding faders work just like the pitch control on a turntable. The play speed of each CD can be individually adjusted by  $\pm 8\%$  and pitch control can be turned off for 0% pitch. Player unit 12.21 lbs., Remote control 3.36 lbs.

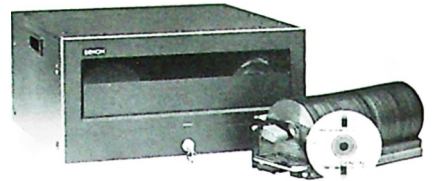

**DN-1200F 200-CD Changer**

High value, system expansion flexibility, enormous capacity, quick access, and compact size makes the Denon DN-1200F Changer the industry benchmark. Its two-magazine storage system holds 10 discs in each rack. Combined with the Denon DN-1200C Controller, a multitude of disc/track programming is at your disposition. The unit features compactness, disc magazines, transport security, rapid pickup mechanism, computer-compatible control and digital output.



**DN-951FA CD Cart Player™**

The Denon DN-951FA CD Cart Player™ combines performance and value, offering greater efficiency and Denon's audio quality. The Auto Track Select System gives programming control of ON AIR playback of CDs. The DN-951FA reads special bar-coded labels, available in 3 different configurations. The narrow profile allows three units to fit across on a rack shelf. Other features include full remote control capability and large digital display.



**DN-961FA Compact Disc Player**

Unprecedented performance with enhanced reliable operating ease, greater efficiency and unsurpassed audio quality make the Denon DN-961FA a broadcaster's dream. Its superior digital audio sound quality is attained from a super linear converter system, with dual 18-bit DACs and an 8 times oversampling, 20-bit dual filter for low noise and transient response. Broadcasters will find features in the DN-961FA which improve the ON AIR playback of CDs.



**DN-970FA Compact Disc Player**

The DN-970FA is intended for professional use in audio, video and film production studios. It features variable speed, quick search and cue time, digital audio outputs, external synchronization and full remote control capability. Your CD disc safely encapsulated in the cartridge - protected from damage and theft, is loaded and unloaded directly into the player. Ease of use and abundance of features makes this CD player suited to the needs of all.

**NAB** Ask your Harris Allied rep about the BROADCAST AND AUDIO SYSTEM TEST CD  
Manufactured by Denon

**ACD5B CD Cartridge**

The clear plastic cartridge for the Denon cart players and Audio-Metrics CD 10, protects the CD from damage of handling, scratches and fingerprints. The cartridge allows the operator to handle the disc the same way as a tape cart. The outside can be labeled or color-coded.

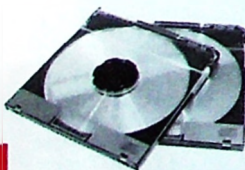

**Audio Technical CD**

This compact disc contains a large number of test signals and musical excerpts which can be used not only to thoroughly check the playback performance of a CD player but to evaluate other audio components such as amplifiers, tape decks, and loudspeakers.



## MARANTZ

### CDR610 Compact Disc Recorder

The Marantz CDR610 Compact Disc Recorder is a complete stand-alone CD recording and playback system. Features include: true AES/EBU digital input/output, transformerless balanced analog input, calibrated for 15dB of headroom at +4dBu (can be adjusted to  $\pm 5$ dB), wired remote control (with two-way control of play/record) connected via an 8-pin Mini DIN connector, 9-pin D-connector parallel I/O and multiple machine parallel cascade operation.



## NAD

### Model 502 Compact Disc Player

The NAD Model 502 is NAD's high-performance, affordable compact disc player. The 502 includes a digital output, so users of DAT, DCC or MD can make a perfect digital copy from compact disc. NAD-Link allows the 502 to relay remote-control commands. Other features include: balanced MASH one-bit high-resolution digital to analog converter, plays 3-inch discs without adaptor, 21 tracks programmable, advanced NAD analog filter configuration and much more!



## SONY

### CDP-2700 Compact Disc Player

The CDP-2700 professional compact disc player from Sony offers outstanding performance and operational facilities including digital-to-digital interfacing capability, rapid start, fader start/stop control from a mixing console and variable speed playback. The extensive use of the latest devices, combined with reliable transport mechanism mounted on a rigid, anti-vibration chassis, makes it the natural choice for professionals where digital audio superiority is required. Rack mountable, it accommodates 5"(12cm) and 3"(8cm) diameter CDs.



## TASCAM

### CD-401 MKII Compact Disc Player

The Tascam CD-401 MKII is an economical high-performance CD player designed for the professional recording, production or broadcast studio environment. The CD-401 MKII comes standard with both balanced XLR and unbalanced RCA outputs. Special ZD circuit ensures sound quality meets demanding standards. A fader-start allows play to start automatically on fade-in and stop at the completion of a fade out. Standard 19" rack mountable. Remote control is optional.



## TECHNICS

### SL-P1200 Compact Disc Player

The Technics SL-P1200 is the professional's compact disc player. Combining impeccable fidelity with unique styling, the SL-P1200 is packed with Technics developments like an FF1 laser pickup, a high-resolution digital filter with double over-sampling (88.2 kHz), Class AA circuitry and specially designed controls. Structural features that isolate and damp vibrations, make the SL-P1200 ideal for discos and studios. Call Harris Allied for other compact disc players from Technics.



## AUDIO-METRICS

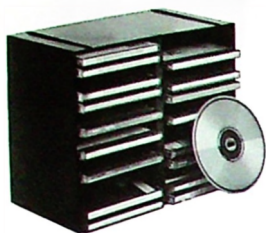

### CAS TCD-30 Jewel Case Storage

Get organized with the Audio-Metrics model CAS TCD-30 jewel case storage cabinet. Great for production and control rooms the CAS TCD-30 is constructed of economical plastic. Designed for jewel cases only. Holds 30 CDs.

Model	Cap	Height	Width	Depth
CAS TCD-30	30	8¼"	10¾"	5¼"

## LIFT

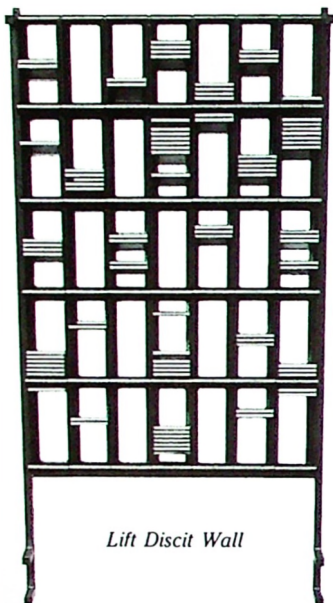

Lift Discit Wall

### Lift Discit Wall

The Lift Discit Wall from Lift Display, Inc., has a 630 CD capacity. The frame is constructed of steel and holds 35 individual discits. Each unit interlocks with ease and allows CDs to be retrieved quickly. The dark brown rail secures to the wall with heavy flanges. Accommodates all single CD cases and the ACD5B cartridge. Some assembly required.

79"H x 41½"W x 7"D.

**34000/16000** - Six bays across, 5 high - (Holds 540 CDs).

**98750/16000** - Seven bays across also available as shown in photo, (Holds 630 CDs).



### Lift CD Storage Cabinet

The Lift Display security storage cabinet system forms a complete CD storage system. The base is secured to the floor and the storage cabinet snaps onto the standard base. The 12" base cabinet (37240) increases overall height. With the snap-in feature, you are able to stack as many as 3 storage cabinets. Constructed of all metal, storage cabinet is lockable. (Holds 840 CD, plastic jewel boxes.)

**Note:** These cabinets will not accommodate the ACD5BCD cartridges.

**37000**, 23¾"H x 45"W x 21"D

**37240**, 34"H x 45"W x 21"D

### Discit CD Holder

The Discit by Lift Display is an interlocking CD organizer which holds 18 single case CDs. Units snap together easily and are constructed of a black, high density polystyrene. Accommodates the ACD5B cartridges. 12<sup>1</sup>/<sub>32</sub>"H x 5<sup>7</sup>/<sub>16</sub>"D.



Discit

## MIDDLE ATLANTIC

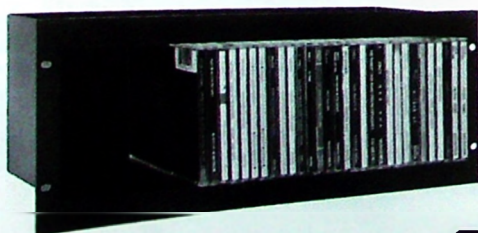

### CD Disc Holder

With the Middle Atlantic model CD disc holder, up to 42 compact discs can be stored in a rack. The discs stand up vertically with labels facing out, and protrude ¾" for easy access. Recommended for stationary installations only. Faceplate .125" aluminum, body .063" aluminum. Welded construction. Brushed and black anodized. 4 spaces tall (7"). Now has separators!

## A-LINE

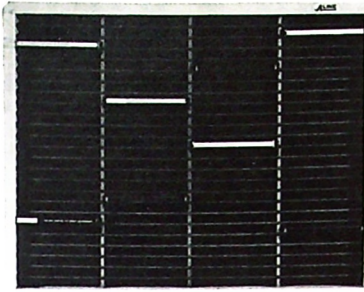

### CD100 CD Storage Racks

A-Line offers the most beautiful and practical CD storage racks available. Built of solid oak frames and full shelves to hold all single CD types. Choose any of 8 models. Now, oak laminate finish also available. Please specify.

Model	Cap	Height	Width	Depth
A/LCD48OAK	48	9 <sup>5</sup> / <sub>8</sub> "	22 <sup>1</sup> / <sub>2</sub> "	5 <sup>5</sup> / <sub>8</sub> "
A/LCD48LAM	48	9 <sup>5</sup> / <sub>8</sub> "	22 <sup>1</sup> / <sub>2</sub> "	5 <sup>5</sup> / <sub>8</sub> "
A/LCD100OAK	100	18 <sup>1</sup> / <sub>16</sub> "	22 <sup>1</sup> / <sub>2</sub> "	5 <sup>5</sup> / <sub>8</sub> "
A/LCD100LAM	100	18 <sup>1</sup> / <sub>16</sub> "	22 <sup>1</sup> / <sub>2</sub> "	5 <sup>5</sup> / <sub>8</sub> "
A/LCD180OAK	180	32 <sup>3</sup> / <sub>4</sub> "	22 <sup>1</sup> / <sub>2</sub> "	5 <sup>5</sup> / <sub>8</sub> "
A/LCD180LAM	180	32 <sup>3</sup> / <sub>4</sub> "	22 <sup>1</sup> / <sub>2</sub> "	5 <sup>5</sup> / <sub>8</sub> "
A/LCD244OAK	244	44 <sup>7</sup> / <sub>16</sub> "	22 <sup>1</sup> / <sub>2</sub> "	5 <sup>5</sup> / <sub>8</sub> "
A/LCD244LAM	244	44 <sup>7</sup> / <sub>16</sub> "	22 <sup>1</sup> / <sub>2</sub> "	5 <sup>5</sup> / <sub>8</sub> "



A/L40CD Oak

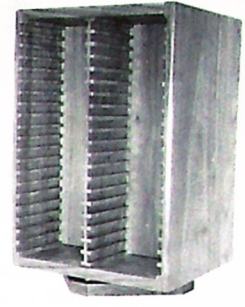

A/L80CD Walnut

### CD Storage Rack Lazy Susans

A-Line's wood lazy susan cabinets are constructed of solid oak or walnut. They hold all single CD cases and have a 15<sup>1</sup>/<sub>2</sub>" turn radius. Two sizes available — 40 capacity and 80 capacity.

Model	Cap	Height	Width	Depth
A/L40CDOAK	40	10 <sup>5</sup> / <sub>16</sub> "	11 <sup>1</sup> / <sub>2</sub> "	10 <sup>1</sup> / <sub>2</sub> "
A/L40CDWLT	40	10 <sup>5</sup> / <sub>16</sub> "	11 <sup>1</sup> / <sub>2</sub> "	10 <sup>1</sup> / <sub>2</sub> "
A/L80CDOAK	80	18 <sup>7</sup> / <sub>16</sub> "	11 <sup>1</sup> / <sub>2</sub> "	10 <sup>1</sup> / <sub>2</sub> "
A/L80CDWLT	80	18 <sup>7</sup> / <sub>16</sub> "	11 <sup>1</sup> / <sub>2</sub> "	10 <sup>1</sup> / <sub>2</sub> "

## ABCO

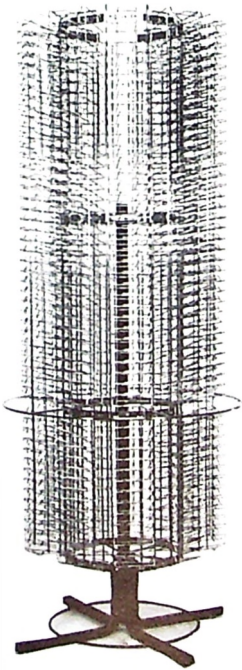

### Lazy Susan CD Rack

ABCO offers two sizes of lazy susan wire CD racks. Both are six feet high and hold all types of single CD cases. Also available as wall stringers. ACD5B cartridge compatible.

ABO 280CD holds 280 CDs, 22" turn radius.

ABO 560CD holds 560 CDs, 27<sup>1</sup>/<sub>2</sub>" turn radius.

## ARRAKIS

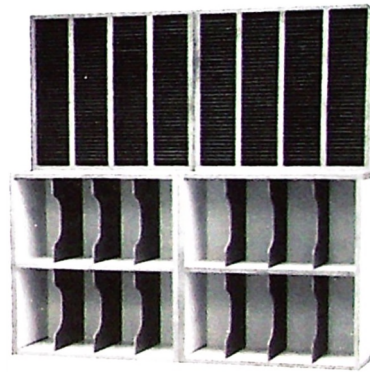

### ZX/CD-160 CD Storage Rack

Arrakis CD storage racks (pictured here mounted on matching LP storage units) are manufactured expressly to be compatible with Modulux™ furniture. They feature solid oak trim, hold 160 discs. They can be shipped via UPS™ or FedEx™. Dimensions: 23<sup>3</sup>/<sub>8</sub>"H x 25"W x 4<sup>3</sup>/<sub>4</sub>"D.

Your Harris Allied representative is waiting to assist you with  
CD Players, Recorders and all Accessories. Call today!

In US Phone: 800-622-0022 - See Pages B & C for Worldwide Contact Information

# ROCK 'N' ROLL GRAFFITI

A Compact Disc Library of the 1950's and 60's

Rock 'N' Roll to 1,200 best songs of the 1950's and 1960's on compact disc! All original versions by the original artist! HallLand Broadcast Services introduces

**ROCK 'N' ROLL GRAFFITI**, a compact disc library of over 1,200 of the most memorable songs of the 1950's and 1960's. After two years of research and thousands of hours in locating the

very best sounding original hit versions of all tunes, we have compiled this broadcast library onto 50 CDs. The tunes are arranged in alphabetical order by artist, so that finding the song you want is quick and easy. This library is perfect for radio stations. Virtually all songs have been sourced from CDs, studio tapes or R-DAT for excellent

audio quality without noise or distortion. All material has been checked against original versions so you're assured of getting the songs your listeners remember and want to hear. No imitations or strange remixes!

**ROCK 'N' ROLL GRAFFITI** has over 1,200 popular songs with the convenience and sound quality of CDs.

# 'THE SEVENTIES'

A Compact Disc Library of the 1970's

"The Seventies" CD library from HallLand is 545 of the best Contemporary Hit Radio and Adult Contemporary hits from the 70's. (NO DISCO) All songs are original versions by the original artists, digitally remastered for incredible sound quality. Currently on the air in over 200 markets worldwide. The Seventies makes an ideal "Gold" library for hit-based Contemporary Hit Radio and Adult Contemporary stations. It's also a perfect "current music" category for Oldies format. The Seventies is on 30 CDs, complete with an extensive database supplied on floppy disc at no extra charge.

CHR SEVENTIES •	WINGS - YOUNG	• DISC 30
CHR SEVENTIES •	HAMILTON - HUES CORP.	• DISC 13
CHR SEVENTIES •	CHAPIN - CLAPTON	• DISC 5
CHR SEVENTIES •	STEWART - SUPERTRAMP	• DISC 27
CHR SEVENTIES •	SEDAKA - SIMON	• DISC 24
CHR SEVENTIES •	DOOBIE BROS - EAGLES	• DISC 8
CHR SEVENTIES •	B.B. KING - LENNON	• DISC 16

# THE EIGHTIES PLUS

The HallLand library comes up-to-date with the latest AC/CHR collection — **The Eighties Plus!** 750 songs on 44 CDs, from ABC, Paula

Abdul and Bryan Adams, through Madonna, Paul McCartney and George Michael to Tina Turner, Wilson Phillips, and Paul Young. With this latest collec-

tion, your station can provide complete coverage from the earliest days of Rock 'N' Roll right up to today's hits. **The 80's Plus! 750 songs on 44 CDs!**

*The Audio-Metrics CD 10 compact disc cartridge machine is the perfect instrument to play the above libraries — and to protect the CD's in the safety cartridge which has become a broadcast standard. Learn more about the Audio-Metrics CD 10 on page 41.*

**MP-10 Portable Mixer**

The AEQ MP-10 portable mixer, unique and totally innovative, allows instantaneous, on-the-spot news coverage to a radio station by means of a common telephone line to send audio via prerecorded tape or to provide live commentary. The unit weighs 9.3 lbs. and measures 13"x9"x3.2". Its power supply is either 220/110/rechargeable batteries. A dual mode telephone dialer permits either pulse or tone dialing. It also features a test tone generator, level meter, 4 headphone outputs, five transformer balanced mixing inputs and a 32 second ID message.

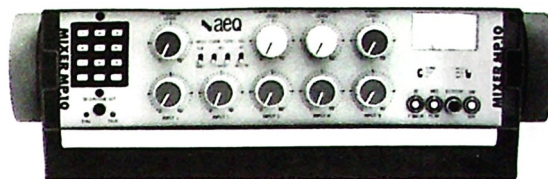

**ALLEN & HEATH**



**GL2 Rack Mount Mixer**

The Allen & Heath GL2 is a smaller, rack mountable version of the GL3, offering 10 mono input channels and 2 stereo input channels. Each channel has a 100mm fader with comprehensive 4 band EQ with 2 mid sweepable frequencies along with 6 Aux sends which have individual level controls and are sensibly grouped with Pre/Post switches. "Status Lock" switches allow the user to quickly convert this console from a 4 sub group console with stereo and mono outputs to a by 6 monitor console. Built in a rugged chassis with the connectors on the back to accommodate rack applications.



**GL3 Mixer**

The Allen & Heath GL3 is well suited for both front of house and on-stage monitor mixing applications. The GL3 offers up to 32 input channels each with comprehensive 4 band mid sweepable EQ and 6 Aux sends. The Aux sends each have individual level controls and are sensibly grouped with Pre/Post switches. Unique panel mounted "Status Lock" switches allow the user to quickly convert this console from a 4 sub group console with stereo and mono outputs to a by 6 monitor console. The GL3 is built in a rugged, yet stylish all metal chassis. Ideal for touring, rental and installed live sound applications.

**ARRAKIS**

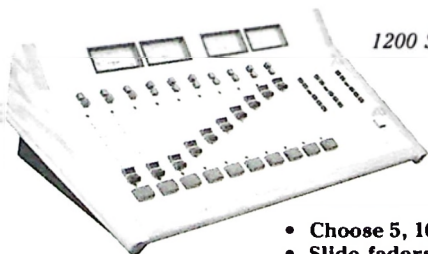

1200 Series

- Choose 5, 10 or 15 input version
- Slide faders standard
- VCA level control
- Telephone mix/minus bus
- Designed with DigiLink in mind

**1200 Series Console**

The new Arrakis 1200 is the ideal series of consoles for the digital broadcast world. Choose the size you need. The 1200 is available in 5, 10 or 15 fader configurations and is designed to complement and support the Arrakis DigiLink hard disk digital audio system. The 1200-5S, -10S or -15S is ideal for live assist on-air, news, talk studio, edit studio and production rooms. A 4-channel turret is also available. The 1200-TRT is specifically designed for and dedicated to the news/talk operation. Four mic channels, each with on/off controls. Headphone level control and removable mic controls for interview guest positions. Talkback provision included. Integrated digital readout countdown timer with thumbwheel sets.

*Certain products not available in some areas.*

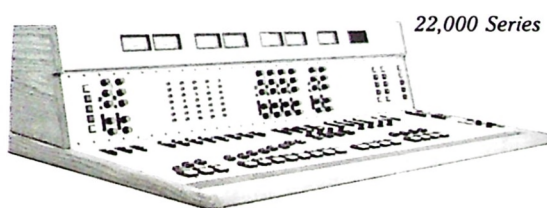

22,000 Series

- On air, stereo production and 4-channel multitrack, all in one
- Digital ready performance
- Modules 100% compatible with 12,000 input/output modules

**22,000 Series Console**

Introducing the new Arrakis 22,000 series of broadcast consoles. The 22,000's flexibility makes it equally adept at many tasks throughout the digital-ready studio of today and tomorrow. A perfect complement to Arrakis Trak★Star and DigiLink hard disk audio products, the 22,000 is an advanced on-air, stereo production or 4-track production version of the best selling Arrakis 12,000 series console line. A typical 20 channel on-air console is affordably designed for the professional. Even a loaded 30 channel 4-track production configuration model will fit your station's budget.

**Ask your Harris Allied rep for full details on Arrakis consoles - the 1200 Series & 22,000 Series.**



ARRAKIS



**TURBO 12,000 Series,  
Modular Audio Mixing Consoles**

The Arrakis TURBO 12,000 Series consoles have new features, new modules, increased performance and durable polycarbonate overlays on all module surfaces. For easy service and installation, the 12,000 Series is entirely front panel modular. There are no electronics on the motherboards. Damaged modules can be easily replaced and new ones added. With three mainframe sizes to choose from (8, 18 or 28 input mainframes), this console fits any possible broadcast application. All modules feature advanced logic control of sources with tally lamps.



**SCT (TURBO) Series**

The 500 SCT pictured above is but one of a family of mixing consoles. The SCT (Turbo) Series is one of the most popular lines of broadcast consoles sold in America. The six available models feature 6, 8, or 12 channels with rotary (as above) or slide faders. These attractive and rugged consoles provide the 24-hour a day reliability your operation requires and the value your budget demands. For detailed information, please ask for the six page, full-color descriptive brochure on the Arrakis SC-Turbo Series of audio mixing consoles.

ATI



BC6DSR

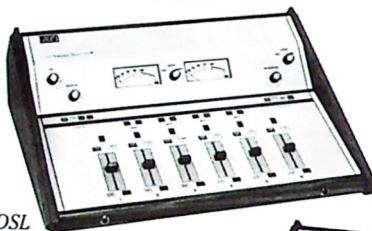

BC6DSL



BC8DSR

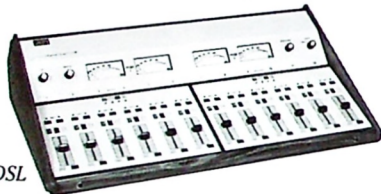

BC12DSL



BC8DSL

**Vanguard Series Consoles**

Vanguard Series Consoles from ATI represent a unique value in broadcast boards. A digitally scanned matrix of long life membrane switches replaces conventional trouble-prone pushbutton and lever key switches for input selection and bus assignment. Logic controlled, current mode FETs switch all audio with no wearout, feed-thru or noise. DC operated VCAs used for all level control functions eliminate the need for expensive audio faders.

The 6 and 8 mixer consoles have balanced inputs, two mono mic preamps with PAN pots, dual stereo program outputs and linear and rotary fader control DBX VCAs. The 12 mixer consoles have twenty-four balanced inputs, two mono mic preamps with PAN pots, dual stereo program outputs plus two Mono Mix program outputs. Sixty mm. linear faders control DBX VCAs. The Vanguard Series provides exceptional performance in the control room or in production.

**MX100/XP100 Mic/Line Mixer**

The MX100 3-channel mic/line mixer and the XP100 4-channel mic/line input expander are the compact and convenient series of low-cost NanoAmps from ATI. Featuring XLR and TRS connectors with high-performance circuitry and quiet loop-thru external power, the NanoAmp Series includes single and dual mic/line amplifiers, stereo headphone drivers, IHF-PRO Interface Converters in 4-channel and bi-directional models and expandable mic/line distribution amplifiers.

The MX100-XLR is a 3-channel mic/line mixer with LED bargraph metering with independent input level adjustments and a master gain control, with selectable +24VDC phantom power. Inputs can be expanded using one of several XP-100-XLRs, XLR inputs/output.

The XP100-XLR is a four input microphone/line expander with independent input level adjustment, selectable 24 VDC phantom power. Used with the MX100-XLR it includes all interconnecting cables (DC and audio) and has XLR inputs.



MX100



XP100

# Vanguard Series™

STEREO  
BROADCAST  
CONSOLES

## Performance, Value and Reliability through Innovative Technology

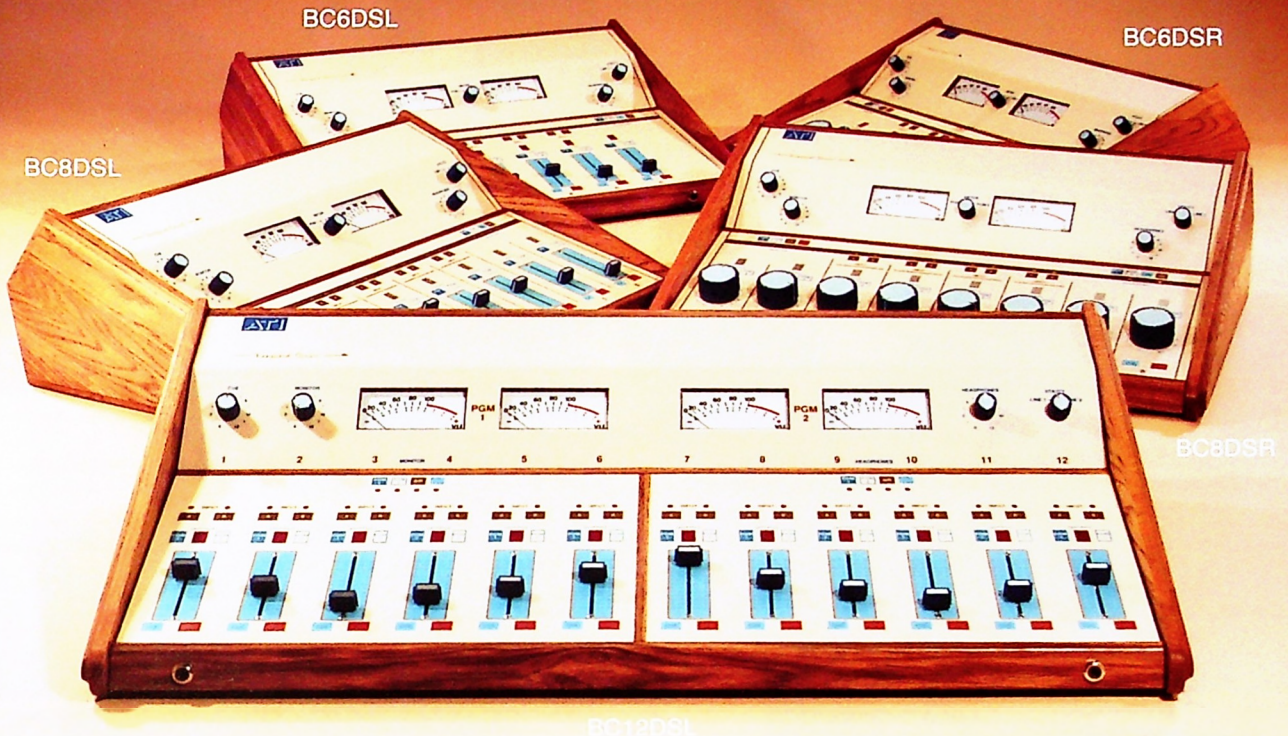

### FEATURES:

- RF proof
- Modular
- Serviceable
- VCA level controls
- Electronic audio switching
- 2 Microphone preamps
- Cue amplifier and speaker
- 4 Input headphone amplifier
- 4 Input muted monitor drivers



AUDIO  
TECHNOLOGIES  
INCORPORATED  
Dedicated to sound engineering

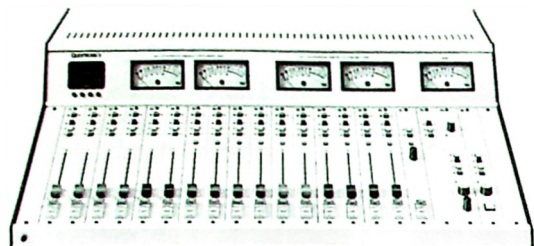

**AirMaster 90 Console**

The Auditronics AirMaster 90 provides a clean, smoother sound, exceptional operating performance, jock-proof reliability and amazing technical specifications. All module logic functions use microprocessor based PIC devices which are OTP software controlled. Stringently tested, it utilizes solid state switching, VCA control, hybrid technology, PIC microprocessors and Tantalum capacitors in all critical signal paths. Ultra-reliable under severe conditions and demanding situations. Available with 8, 12 or 16 inputs.

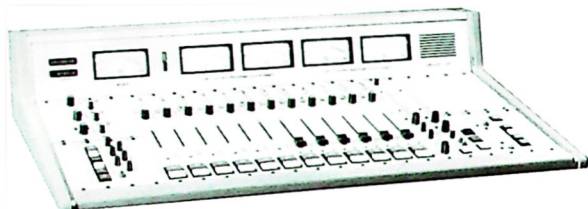

**210 Series Consoles**

Auditronics' 210 radio console looks remarkably similar to their 12-year-industry-leading 200 radio console...until you look beneath the surface. Inside the 210 you'll find improvements in every section you can hear and use. From lower-noise input preamplifiers to transformerless output modules. From overbridge and broader accessory selection to standard clock/timer with sequencer capability that you can slave to your house system.

All modules include an upgraded telephone interface with direct recorder output that doesn't require an input module or third bus. All output modules are identical full-featured stereo, interchangeable at will.



**800/850 Series Consoles**

The 800 Series console from Auditronics is designed as an On-Air console for disc jockey operation with some production applications. The complementary 850 Series has additional capabilities which include signal processing or input pre-selection physically above and electrically in-line with each input module. Each come in three mainframe sizes of 12, 18 and 24 input modules. Stereo Program, Audition, Utility and Auxiliary out busses, 2 mono Mix-Minus output busses and L + R output summing are provided. Each has the most extensive user-programmable logic control system in the industry. Electrical specifications are compatible with both DAB and digital technologies. Both are affordable and will enhance your on-air signal.

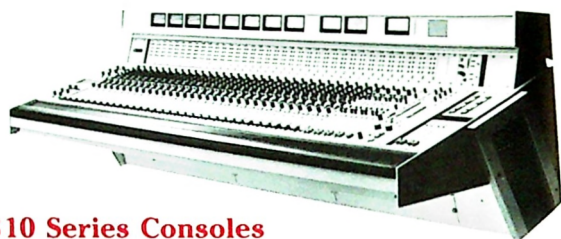

**310 Series Consoles**

The Auditronics 310 Series audio production console is a total concept in audio processing and control. Designed as a building-block system for both small and large facilities, the 310 Series represents an advanced design in audio control technology. The Series 310 features leading edge technology, expanded functional capability and advanced ergonomic design.

Features include 4 or 8 outputs, output submastering, mix-minus capability, mono and/or stereo inputs, mix output, 4 auxiliary sends, and auxiliary returns. Also control room monitoring, stereo solo system, aural phase check capability, stereo headphone monitoring, output metering, mic phantom power supply, and built-in monitor mixer.

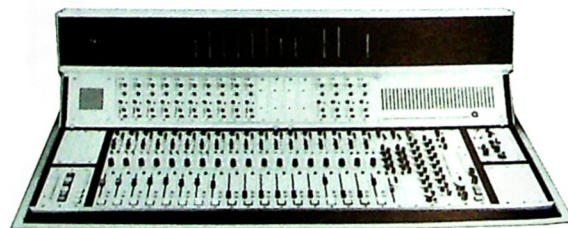

**400 Series Consoles**

The Auditronics 400 Series audio console is the best available choice for the broadcast professional who desires to do multi-track production without having to purchase an expensive multi-track recording console. Specifically designed from the frame up with all the features required for multi-track broadcast production, this console allows your creative people to deliver their best work in the least time with the greatest convenience. The 400's modular design allows you to select the console's optional modules to suit your particular application. And you can change the configuration any time in the future to meet your continuing growth needs on a plug-in basis. Mainframes available with 18 or 24 inputs with 4 or 8 sub-master output busses.





Andy & Debbie Montgomery and Capt'n. Pat Adams, the morning team at KIX-106 in Memphis, Tennessee.

## We Make a Good Team!

KIX-106 is the number one country music radio station in the Memphis area. When they decided to remodel and expand their studios, the most carefully researched item on the equipment list was a new console for their on-air studio.

So they purchased the Auditronics 800 Series console.

Doug Gossett, their engineer, said some really great stuff about it, but we didn't want to get technical. Let's just say the specs are definitely superior.

However, Andy Montgomery, one-third of the KIX-106 morning team, said some really good stuff too... "Our entire studio is designed around the Auditronics 800. You might say that the 800 and, of course, Debbie are at the center of everything (Debbie's my wife, so I had to say that). It's reliable and it's sturdy. Have you ever spilled a cup of coffee or a soda on your console and everything shuts down? I don't recommend it, but so far this hasn't been a problem for the 800. It's so versatile. It does everything I need and it always works. That sure makes my job a lot easier. Debbie, Cap'n Pat, the 800 and I make a good team!"

"It's hectic on our morning show and we get lots of phone calls, especially Debbie. This new telephone mix minus system makes them so much easier to handle."

"There are always the three of us on the air in the morning, but it's not unusual to have 5 or 6 people in the studio and on the air at the same time ... plus the music, the commercials and the phone calls. And we still haven't begun to max out the console. It's so reliable that I don't think Doug has had to make even a minor adjustment or anything since we started using it."

If you want to find out what Doug and other users had to say about the Auditronics 800 console, call your favorite Auditronics dealer or Auditronics today.

*The Sound Of Perfection*

**AUDITRONICS**

**AT-MX341 Automatic Microphone Mixer**

The AT-MX341 SmartMixer is ideal for teleconferencing, seminars, meetings, radio and TV broadcasting as well as A/V applications where hands-off audio must be easy to install, operate and completely transparent. Mixes four microphones or more when daisy chained. Features include micro processor controlled, automatic silent switching four-channel mic mixer, master threshold setting for all channels with priority switch for each channel, choice of one-channel-at-a-time operation, all active of any mix or moderator override. The unit is powered by a plug-in transformer.



AUTOGRAM



**AC-6 Mono/Stereo Audio Console**

The AC-6 Mono/Stereo Audio Console from Autogram features the following input characteristics: 23 stereo inputs (plug-in modules optional); 1 high-level cassette; microphone, 200 or 50 ohms; high-level 10K ohm bridge or 600 ohm terminated; external monitor 10K ohm, as well as microphone levels of -65 to -50 dBm (high level -10 dBm to +10 dBm). Output characteristics include: 1 stereo program; 1 stereo audition; 2 monitor amplifiers; 2 headphone amplifiers; 1 cue amplifier. Power source is 117 or 230 VAC 50-60 Hz single phase.

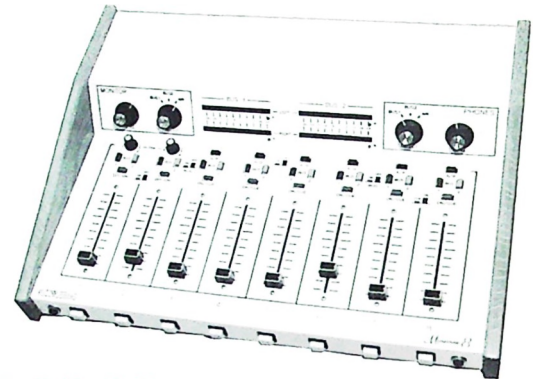

**Mini-Mix 8 Console**

The Autogram compact, light-weight Mini-Mix 8 table-top console shows that good things can be economical and come in small packages. Weighing only 9.5 lbs., and measuring 4.75"x15.5"x19.38" the Mini-Mix features a rugged aluminum case with oak wood end panels. The panels contain 8 plug-in side pots. 12 stereo inputs, 2 mic inputs, 2 stereo balanced busses and 2 stereo unbalanced busses. It's all VCA operating and has a cue amplifier/speaker built-in. Power source is either 117 or 230 Volt AC.



**R/TV-12 Stereo Audio Console**

The R/TV-12 stereo audio console is one of the latest innovations from Autogram with features such as: 8 dedicated pots, 4 pots with 4 inputs each, electronic switching, no audio transformers, Penny & Giles linear conductive faders, Schadow selector switches, pluggable miniature terminal strips, up to eight patchable microphone preamplifiers, each channel remotely controllable, easy input level selection.

The R/TV series is also available in a 20-fader version with 18 dedicated faders. Two faders are able to accommodate 8 inputs each.

R/TV-12 - Twelve Faders  
R/TV-20 - Twenty Faders

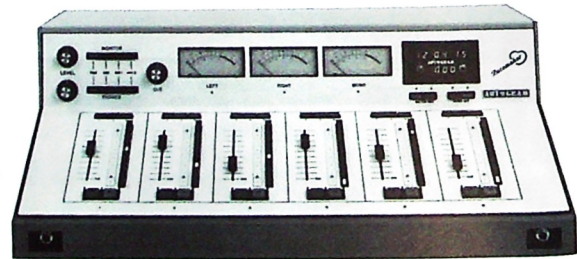

**Pacemaker 648 Console**

The Pacemaker, Autogram's cost-conscious console series, features Penny & Giles faders; electronic switching; no audio transformers; pluggable-miniature terminal strips; new legend system, input level selection; front panel assignable mix minus bus; a smaller lower profile cabinet. The Pacemaker 648 has 6 faders with 8 inputs per fader giving a grand total of 48 inputs for your maximum dollar per input value.

The Pacemaker is also available in an 8-fader model known as the 828B with 6 faders of 2 inputs each and 2 faders of 8 inputs each featuring 28 total inputs. A 10-fader model known as PM-1032 has 8 faders of 2 inputs each and 2 faders of 8 inputs each. Featuring 32 stereo inputs, also 5 meters.

## BROADCAST ELECTRONICS

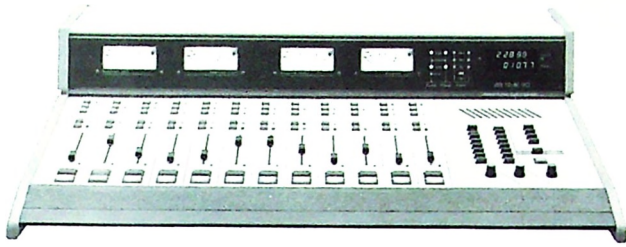

### Air Trak 90 Series Consoles

The AIR TRAK 90 is a broadcast console with infinite reliability and zero-maintenance. Whether you decide upon the 6, 12, 18 or 24 channel AIR TRAK 90, each has been designed for smooth and efficient operation. Operator controls are all within easy reach, with frequently used controls located nearest the operator, while input/output selectors are at the top of the board. Unlike other audio consoles which use VCA's just on the inputs, the AIR TRAK 90 utilizes VCA's on all audio controls, including monitor and head-phone gains and are ideal for multiple studio stations.

**Harris Allied carries the complete Broadcast Electronics console line.**

## ELECTRO VOICE

### ELX-1A Broadcast Mixer

The Electro Voice ELX-1A broadcast mixer packs the features you've asked for in a "friendly" format that's easy to use. In the studio or on the scene, the ELX-1A delivers the same exceptional performance, with versatility and dependability. Electro Voice has taken the popular ELX-1, reduced the price, deleted the battery pack and added a rack-mount chassis. All of the other great features of the ELX-1 have been retained, while eliminating the need for external rack-mount hardware.



## HENRY



### MicroMixer Stereo Utility Mixer

MicroMixer is a nifty four-input, two-output stereo utility mixer. It's essentially a "micro-console-in-a-box." Each of the four line level inputs is balanced and bridging, and will accept an input level from -10 to +8. There's a gain control for each input which has a range from "off" to +10 dB gain. "Micro-assign" switches permit the inputs to be assigned to the Left, Right, or Both outputs in any combination. Use MicroMixer to combine two stereo sources, four mono sources, add mono to stereo, combine stereo to mono. . . hundreds of uses! The stereo outputs will drive a 600 ohm load to +25 dBm. DC coupled circuitry for great specs: DC-30 kHz, -80 dB noise, .008% distortion.

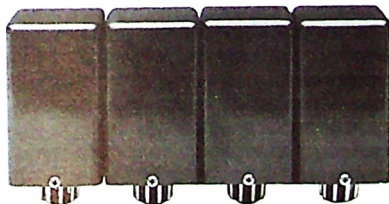

### Retrofit Modules

Upgrade older Autogram and Collins consoles with Henry retrofit modules. A console equipped with Henry modules will exhibit frequency response of 3 Hz to 30 kHz, .02% THD, 80 dB noise floor, and perfect transient response.



### Fast Trac II Stereo Mixing Console

The Henry Fast Trac II is a comprehensive 7-input, 2-channel stereo mixing console. Fast Trac II is an incredibly useful audio management system that has numerous applications in radio and television audio. In a nutshell, Fast Trac II is a complete 2-pot console "Studio-In-A-Box." There are six inputs for stereo line-level sources, and one monaural microphone input. Mic audio can be mixed over any stereo Line source selected. Fast Trac II is ideally suited for critical dubbing and production tasks. The most distinctive feature of Fast Trac II is its timed auto-start Machine Control System. When used in a dubbing application, Fast Trac II will automatically start both the source machine and the recorder at the appropriate times to ensure perfectly-cued dubs with one-button ease.

Ultra low-noise MA10 mic preamp with adjustable gain. Transformerless design eliminates mic loading for improved bass response and clarity. Replaces original MPA preamps.

Use model LA1 instead of transformers for line level sources. Adjustable gain matches any source -20 to +8 dB without pads, boosters. DC coupled. Replaces BT and MT transformers.

The new technology of the SA10 summing amp eliminates all capacitors in this critical stage. Improved S/N, extends LF response to below 3 Hz. Replaces original MXA series mixer amplifier.

The new OA10 program and VU meter output amplifier features balanced output to +26 dBm without a transformer. DC coupled for perfect square waves and output for VU meters. Replaces original LA series modules.

*Certain products not available in some areas.*

**HARRIS  
ALLIED**



## The Dynamax MX Series With Enhanced New Feature Set Now Available in up to 18 Channels

- True modular design
- Ultra-reliable motherboard construction
- VCA mixer and monitor control
- Active balanced line inputs, transformer isolated mic inputs
- Active balanced main and monitor outputs
- Full monitoring/cueing facilities with VCA level control and active source selection
- Built-in cue amp with speaker and amplified stereo 8-ohm headphone output
- Independent remote start for each "A" and "B" input
- Opto-isolated remote module on/off
- Selectable fader start
- Two inputs per module, mic/line or line/line – line inputs may be mono or stereo, consumer or professional format
- Four assignable outputs – two stereo plus two mono
- Available in 10, 12, 14, 16, or 18 channel models
- Independent level controls for each "A" and "B" input
- Separate audio and logic power supplies
- Sturdy, all-steel construction
- Durable Lexan overlay control surfaces
- Count-up event timer standard
- Two input expansion switches standard
- Excellent RF immunity



**DYNAMAX**<sup>®</sup>  
BROADCAST PRODUCTS BY FIDELIPAC<sup>®</sup>



MX 8R

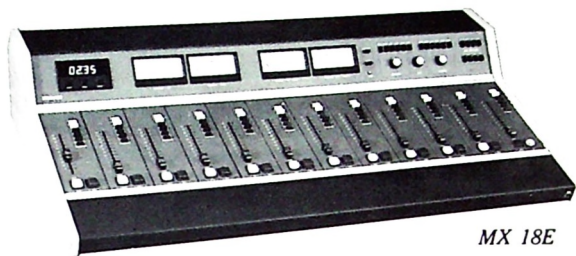

MX 18E

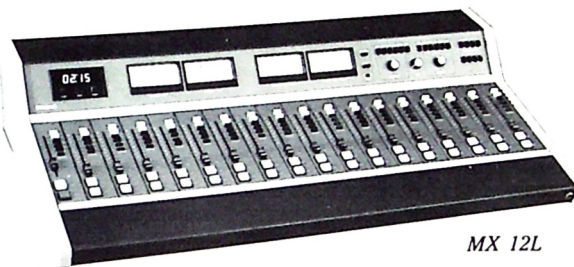

MX 12L

## Dynamax MX Series Modular Audio Console - MXR, MXL, MXE

The Dynamax MX Series is a true breakthrough in the field of cost-effective audio mixing consoles. The MX Series consoles have a spacious, easy-to-use layout and are available with either rotary or linear faders.

The MX Series is available in three configurations, MXR, MXL and the MXE. The MXR is equipped with rotary faders and is available with 6, 8, 10 or 12 mixers. The MXL is offered with linear faders in the same configuration as the MXR.

The new MXE is equipped with narrower modules and linear faders and is available in 10, 12, 14, 16 and 18 channels. The MXE incorporates numerous significant new features including fader start, pre-fader patch points, independent gain controls for A and B inputs, remote module on/off, and convenient remote start terminals to simplify installation.

The MX Series ultra-reliable motherboard has no active electronic components. Each input module includes all of the active circuitry necessary for its operation. The MX Series has all the features the professional broadcaster desires.

The MX Series uses the highest quality components and construction techniques, resulting in excellent RF immunity and a rugged, sturdy product that will last for many years. Call for complete specifications on the entire MX Series Consoles.

## BROADCAST AUDIO (Division of Fidelipac)

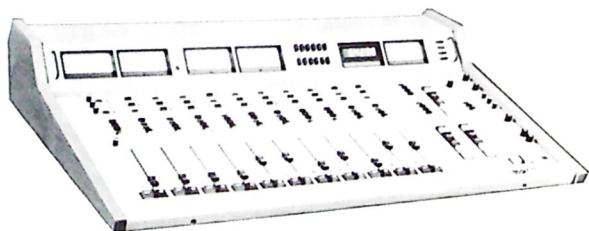

### System 12-VI Audio Console

Series VI audio consoles sound great, are easy to use, and have sensible, reliable electronics for absolute dependability. The attractive low profile design is recessed only 2.5 inches into the desk, for maximum leg room. The armrest and panels are available in either solid oak or walnut hardwoods. A digital timer, peak overload indicator, equalizer headphone monitor, and dual studio monitor outputs are standard. Each mixer has both an active balanced stereo line input, and a transformer balanced mono mic input, so all mixing positions are interchangeable. Three relays and 11 open collectors for mute/control. A universal output amplifier is used for stereo cue, stereo headphone and line outputs. Separate amplifier cards are used for left and right channels, for even greater redundancy. Hall effect "off/on" switches are also standard.

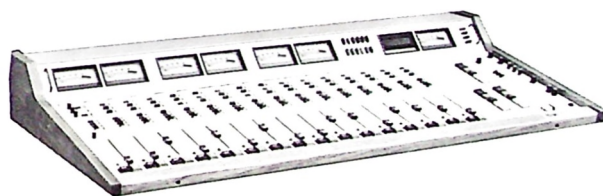

### System 20-VI Audio Console

System 20-VI features 2-inch modules, which enable up to 20 mixers or optional panels to fit into the same mainframe as the popular System 16-IV. Four muting or control relays, and 17 open collector outputs are standard. The use of double-sided ground plane motherboards assures minimum noise and crosstalk, plus effective RFI rejection. The low profile design is recessed 2.5" into the desk, for maximum leg room. Other versions are available with 16 and 24 mixer capacity.

- System 20-VI with 16 mixers
- System 16-VI with 12 mixers
- System 24-VI with 20 mixers.

**SYSTEM 8-VI AUDIO CONSOLE** — with 6 mixers. The 8-VI is engineered with slide faders 2" apart, 1 stereo, 1 mono output and EQ mixer in #1. Console width is 20-1/5 inches. Call for complete specs.

**LPB**



**LPB 7000 Series Consoles**

The all-new LPB 7000 Series consoles are durable, flexible and user-friendly. Available in 12 and 18 channel stereo models, the 7000 Series has an exceptional list of standard features: two inputs per channel, three stereo buses, one mono mixdown, three stereo and three mono tape outputs, stereo mic/line/high-level inputs, mic processing ports built-in, 2 illuminated VU meters for Program, 2 user-selectable illuminated VU meters and 2 illuminated VU meters for Audition (on 18 channel only), built-in talkback and mix-minus, digital event/cumulative timer, built-in cue speaker, 4 independent mute monitor outputs completely programmable muting for all inputs, programmable remote starts, channel on/off controls, separate rack-mount power supply. Fully modular plug-in input and output cards are secure behind a solid front panel, digital logic controls, gold contacts and Penny & Giles 3000 Series linear faders.



**Signature III Series Console**

The LPB Signature III Series console, long ago established an industry standard for longevity and value for the dollar. Thousands of Signature Series consoles are in operation worldwide (from New York to Bangkok), and continue to gain praise for their ability to withstand the most rigorous studio conditions. With proven superior RF immunity and heavy-duty switches, it is no wonder nearly one-half of Signature owners own more than one.

The Signature III Series is available in 6, 8, 10 and 12 channel stereo models and 6, 8, 10 channel mono. All Signature III consoles feature two buses, remote starts, 3 inputs per channel, an internal monitor amp, and separate tape outputs. Options include a plug-in mono-mixdown for stereo consoles and a telephone mix-minus plug-in for all Signature consoles.

**MACKIE**



**MicroSeries 1202 Audio Mixer**

The MicroSeries 1202 has a working signal-to-noise ratio of 90dB, distortion below 0.025% across the entire audio spectrum, switchable +48 volt phantom power and +28dBu balanced line drivers. The footprint is under one square foot, yet packs an amazing total of 20 inputs. There are 4 mono channels and 4 stereo input channels.



**CR-1604 Audio Mixer**

The CR-1604 from Mackie is a 16 channel audio mixer designed for non-stop, 24-hour-a-day professional duty. The CR-1604 is unique in that it is part of a mixing system. The mixer may be physically configured in a variety of ways: pod to back or pod to top. Up to 3 units can be combined effectively.

**RADIO SYSTEMS**



**RS Series Consoles  
6, 12, 18 and 24 channels**

The Radio Systems RS Series consoles are rugged and full-featured to last a life time. High audio performance with less than .02% distortion, super-low noise and excellent crosstalk specifications as well as low RFI susceptibility are just a part of the professional performance you can expect. Available in 6, 12, 18 and 24 fader sizes. All have 2 inputs per fader, 3 output buses and more, call us!

**RAMSA**



**WR-S4400 Series Consoles**

The Ramsa WR-S4400 series includes 12, 16 and 24-channel professional 4-bus mixers. The 4400 Series inputs feature switch selectable A & B inputs on each channel to extend mixing power. The equalization provides low noise, low distortion and excellent sound quality. To reduce pickup of external hum and noise, these mixers include balanced inputs and outputs on all channel inputs, all 4 group outputs and the master left/right outputs.

# YOU CAN RELY ON LPB®

*Everyone knows the LPB Signature Series is the industry standard for rugged reliability.*

*The LPB tradition of durable, reliable, easy-to-use consoles continues in our new linear fader consoles.*

## Industry Standard LPB Signature III Series



With over 3,000 units in operation worldwide, the LPB Signature III console represents a standard others are still unable to match. The

Signature Series has proved its ability to perform on 6 continents, in settings ranging from metropolitan to jungle. With an incredible record of ruggedness and easy maintenance, it's no wonder over half of the

Signature console owners have more than one. Features include 3 inputs per channel, two output buses and plug-in electronics. LPB Signature III consoles are available in

6, 8, 10, and 12 channel stereo and 6, 8, and 10, channel mono models.

The LPB 7000 Series takes the standards of the Signature III a step further, adding more features than any other console in its price range. With front panel switches rated for 5,000,000 operations, gold contacts, plug-in modular electronics and more, the LPB 7000 Series has the durability radio and TV stations worldwide expect from LPB. Features include two inputs per channel, three stereo output buses with one mono-mixdown standard and two more optional, user configurable muting and remote starts, and much more. Available in 12 and 18 channel stereo models.

## All New LPB 7000 Series



*It doesn't matter which LPB board you choose, you'll get a console you can count on 24 hours a day. One you'll keep for a long time. Ask any LPB console user - they're all around you.*

# LPB®

RANE



**SM26 Splitter Mixer**

In its most basic configuration, the Rane Model SM26 Splitter mixer is a six to two line level mixer. It will accept six balanced or unbalanced line level inputs which are applied to six level and pan controls. The result of the mix is sent to an overall main output level control and appears at the left and right output jacks on the rear. In its splitter mode, the SM26 can take one or two line level inputs and split these to any of the six mono outputs on the rear. The SM26 may also be used as a six input, six output buffer amplifier as well as being used in a combination of modes at once. The front of the SM26 comprises a master input level control, six channel level controls, six mix/pan controls and an output level control. The rear of the SM26 provides two master inputs, six channel inputs, six channel outputs and two master outputs. All inputs on the SM26 are 1/4" active balanced/unbalanced and all outputs are 1/4" floating unbalanced.



**MP24 Mixer Preamplifier**

The MP24 Mixer Preamplifier is a night club mixer developed to break down the limiting barriers of previous mixer designs. Featuring four stereo input mixing channels and easily suits the needs of the most complex audio/video installations. A total of six stereo line inputs are available plus three stereo phono inputs. The microphone section of the MP24 handles two microphones simultaneously. Both may be contoured by the three-band microphone equalizer as well as a microphone channel insert jack.

RDL



**ST-MX3 Line Level Mixer**

The Radio Design Lab ST-MX3 is one of three mixer modules in the "stick-on"™ series of products. It provides audio mixing of three line level inputs with individual input gain adjustment. The line level output is capable of driving into either high or low impedance, balanced or unbalanced loads. The output may be connected in parallel with other RDL™ mixer modules to expand your system to the configuration your system needs.

SHURE



**FP31 Portable Mixer**

The model FP31 is a compact, portable microphone mixer specially designed for electronic news gathering (ENG) and electronic field production (EFP) use including film, video and remote broadcast applications. The FP31 provides a wide, flat frequency response, low distortion, and up to +18 dBm output. The unit features extremely low internal noise and switchable low-cut filters for each input that effectively rejects low-frequency handling and wind noise. 400 Hz slate tone, 1 kHz cue tone.



**FP32A Portable Stereo Mixer**

No other portable stereo mixer offers comparable performance as many features in such a compact package (3.5 lbs. - 2 1/4" x 6 3/8" x 7 1/4"). The FP32A operates anywhere in the world on two 9V alkaline batteries — for at least 8 hours, or can be powered by an 12 to 30 VDC power supply. A multitude of features includes compact, lighted VU meters, pop-up pan pots, LEDs, link switch, microphone bus, monitor switches, internal DIP switches, balanced inputs/outputs, gain controls and more — plus accessories.

**FP42 Stereo Mixer**

The FP42 is a 4-input, 2-output, compact, self-contained stereo mixer for applications in broadcasting and recording. The high-reliability FP42 integrates all the operating features of a professional stereo mixer in a single unit — small and lightweight enough for location use, but with the reliability of a studio console. Most of the functions of the FP42 (3 1/8"H x 12 7/32"W x 9 1/16"D) are available in the more compact FP32A.





## SHURE



### M267 Mic Mixer/Remote Amplifier

The Shure model M267 is a professional microphone mixer/remote amplifier. The excellent performance, versatility and features of this complete, compact console make it suitable for studio, remote, or sound reinforcement use, and as an add-on mixer for expanding existing facilities. It is also ideally suited for use with audio and video tape recorders to provide multiple microphone inputs.



### FP410 Portable Automatic Mixer

This new concept in mixing gives you "hands-off" automatic mixing! In less than 4 milliseconds, the Shure FP410 selects and silently activates the most appropriate of 4 microphones nearest to the talker for seamless operation — and up to 25 Intellimix may be linked (meaning 100 mics could be automatically mixed). Reduced comb filtering, NOMA circuits "Last MicLock-On" circuits give you flawless performance. Operates on 80 to 132 Vac or 160 to 264 Vac or two 9V batteries. Rack mountable.

## SOUNDCRAFT

### 200 Delta Series Compact Console

The 200 Delta is a compact console suited to any application from theatre stage mixing and A/V conferences to home recording studios and live sound reinforcement. The 200 Delta supplies +48V phantom power for condenser microphones and active DI boxes. Padless input amplifier design controls both mic and line inputs, providing a mic sensitivity range of -2dBu to -70dBu. The 3 band EQ section features fixed HF and LF controls with a swept frequency MID range, all of which use center detent level controls for rapid re-setting to flat response.



*Harris Allied carries the complete Soundcraft Line.  
Call today for complete information.*

## TASCAM



### M108 Rack Mount Mixer

The M-108 rack mount mixer from Tascam features 8 mike or line inputs in addition to 2 pairs of stereo line input channels analog with 4 group outputs. Inputs 1-4 have XLR type microphone input connections. There are also two effects send and an AUX sends. Each of the main inputs has high and low EQ and pan pots. Two fast response LED peak meters and meter select switches that display levels on any of the main busses or the AUX buss.

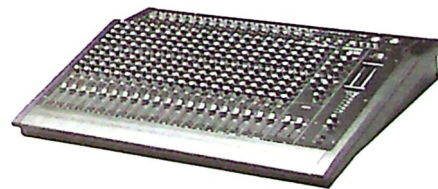

### M1024 Stage Mixer

The Tascam M-1024 stage mixer is ideal for a wide range of live applications such as PA, sound reinforcement and MIDI keyboard mixing. The M-1024 has a combination of mono and stereo input channels and offers clean, transparent sound. Designed for easy integration into just about any type of sound system, the M1024 is compact and portable. 16 Mono and 4 stereo channels, mono channels offer both XLR and 1/4" phone jacks for broad connectivity. Further versatility is provided by a total of 6 auxiliary sends, 4 stereo effect returns and 2 mono effect returns.



M-1508



M-2516



M-1516



M-2524

## M-1500 Series Mixing/Recording Consoles (1508 & 1516)

Two M-1500 configurations are available from Tascam to match your system and source requirements. The M-1516 with 16 input channels and 4 output groups and the M-1508 with 8 channels and 4 groups. Both feature in-line monitoring and multi-function Dual Mix. Essential for recording, this gives you stereo monitor and stereo effects send capability, and the ability to double the console's input capacity. Perfect for when you need to handle a large number of sources such as virtual tracking at mixdown. The M-1500 is smooth, efficient and simple to operate. With features like Direct Out switches, 8 input channels can be quickly re-routed to a multitrack recorder without the need for patching. Top-access connections make patching quick and easy when it does become necessary. Both the M-1508 and M-1516 have elaborate monitoring systems.

## M-2500 Series Recording Consoles M-2516 & M-2524

The Tascam M-2500 Series of recording consoles, available with 16 or 24 inputs, offer the perfect blend of performance, capacity and sophisticated mixing versatility with speed, comfort and convenience. The essence of the recording console is its recording configuration such as a multitrack deck I/O configuration, direct out-group assignment and in-line monitoring. Both consoles feature eight-buss recording and automated muting via MIDI commands. Designed as task-oriented production consoles for recordist and electronic musician, each channel on the M-2516 and M-2524 features in-line stereo monitor, 4 auxiliary sends, 3-band/2-sweep equalization, pre-fade listen, mute and assignment switches for groups 1 through 8. The master section includes 2 stereo and 2 mono effects, both of which are fully assignable. The M-2500 Series also offers balanced and phantom powered mic jacks.

# TELFAX



GX 300



GX 400



GX 440

## GX Series

The GX-300, GX-400 and GX-440 are three new phone remote mixers which represent a major advancement in features, performance and compactness. All units measure only 6.1"x9.4"x1.5" and weight three pounds or less.

All units have a built-in peak limiter which prevents over-driving the phone line. Each unit also has an auxiliary output jack that can be switched to mic or line level. The squelch function on all three units can be switched on whenever an announcer needs to keep crowd noise out of his microphones while communicating with the studio.

All three units feature tone/pulse dialing, radio monitor input jack and switch, standard 1/4" mono headphone jacks, active balanced mic inputs with A3F type connectors and many extra features, including interfacing with low frequency extenders.

The GX-300 has 3 input channels plus the transformer balanced Aux. input. The GX-400 adds a fourth mic channel and a second Aux. input. Channel 4 features a Cue circuit for use with Mic Input #4 or Aux. #2. The GX-440 adds two phone line capability, allowing closed-circuit headset audio for studio cues. It also has an up/down timer with a large LCD display.

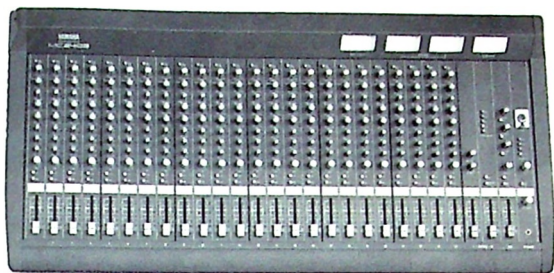

## MC03 Series Mixing Consoles (8, 12, 16, 24)

The Yamaha MC "03" series of compact, lightweight mixing consoles are perfect for straightforward, reliable sound reinforcement applications. Packed with advanced Yamaha technology and features the MC "03" series has pan control, cue switch, linear channel faders, 3 auxiliary sends, 3-band equalizer, input pad and gain controls with peak indicator, meter switches, assignable talkback, phantom master power switch and more!

**MC2403 - 24 In/stereo & mono out**

**MC1603 - 16 In/stereo & mono out**

**MC1203 - 12 In/stereo & mono out**

**MC803 - 8 In/stereo & mono out**

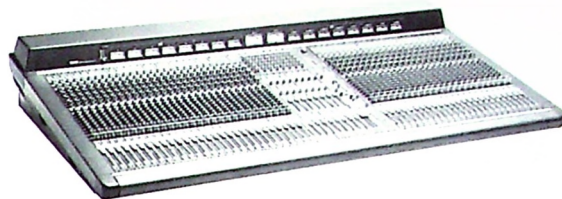

## PM4000 Series Professional Audio Mixing Console (24, 32, 40 or 48)

The Yamaha PM4000 Series is a professional audio mixing console with great performance and reliability. The standard configurations have 24, 32, 40 or 48 mono inputs plus 4 stereo inputs. The 8 VCA master faders can be assigned to control any combination of input channels. There are eight group mixing busses and a stereo mixing bus. Also, 8 monaural auxiliary mixing busses use two pair of stereo auxiliary mixing busses. An 11x8 Mix Matrix saves a tremendous amount of time and effort for complex mixes. Fourteen or eighteen VU meters gives a comprehensive view of signal levels.

**PM4000-24**

**PM4000-32**

**PM4000-40C**

**PM4000-48C**

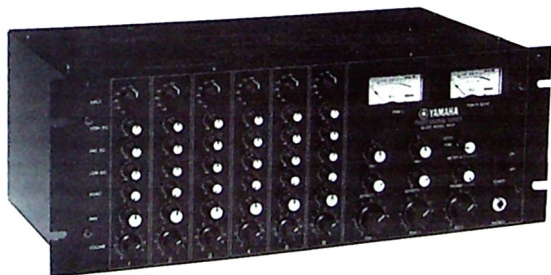

## M406 Stereo Mixer

The M406 is a six input channel, stereo output sound reinforcement mixer with 3-band EQ and 6-position input level trim controls. Excellent as the sole mixer in small clubs, meeting rooms, schools and churches. With +24 dBm 600 ohm balanced XLR outputs internally modular construction in a compact, rack mountable package.

# ZERCOM

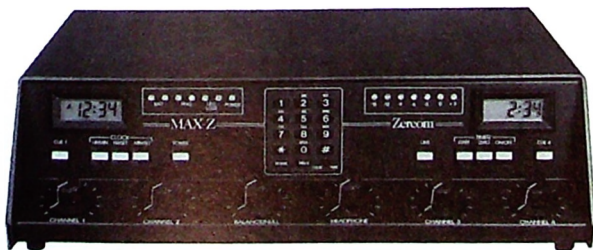

## MAX-Z Remote Broadcast Console

MAX-Z is a remote broadcast console that provides maximum flexibility, utility, and above all, audio quality. A short list of standard features includes 4 high- or low-level inputs (mic or line), 4 headphone outputs, modular telco jack, tone or pulse touch pad dialing, carrying case, built in rechargeable batteries and charger, clock stopwatch/timer, VU meter, and cue channel.



## MAX-Z-II

If your needs are for the same quality in a smaller package, check out the MAX-Z-II. Half the facility of the MAX-Z with the same world class quality. 2 high- or low-level inputs (mic or line), 2 headphone outputs. Almost everything else is the same as its big brother "Z." Includes carrying case.

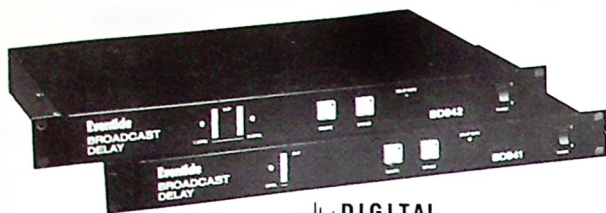

**BD941/BD942 Broadcast Audio Delay**

Eventide has developed the BD941 and BD942 Broadcast Audio Delays for controversy oriented talk radio formats. Now reliable, efficient obscenity protection is so cost-effective even radio stations that only program occasional live talk shows can afford it. The mono BD941 is available in 6 and 12 second versions — the stereo BD942 offers 3 and 6 seconds of delay. All versions feature full bandwidth and inaudible distortion.

The BD941 and BD942 give you ample time to keep abusive or obscene language from offending your listeners. And they perform this key function in an affordable and convenient system. Just hit the "delete" button and the offensive language never reaches the air. The delete function also closes a relay contact. With an easy built relay box, this can automatically start a cart or anything you want. When the delay period plays out your BD941 or BD942 switches you back "almost live" on the air with full delay protection restored.

The BD941 and BD942 deliver 5 — 20,000 Hertz audio frequency response with true 16 bit resolution and a 44.1 kHz sampling rate. Plus negligible distortion, full stereo separation and phase integrity.

**BD941 Broadcast Delay Line (20kHz, Mono)**

- 6 seconds, fixed delay
- 12 seconds, fixed delay

**BD942 Broadcast Delay Line (20kHz, Stereo)**

- 3 seconds, fixed delay
- 6 seconds, fixed delay



**BD980 Broadcast Audio Delay**

Here's how Eventide takes the hassles out of radio talk show production with the world's most advanced broadcast delay — the BD980 audio delay. Eventide's patented automatic catch-up feature solves the problem of getting back into delay after a segment is "dumped." The dump button is pushed to prevent an obscenity or anything undesirable from reaching the air. The obscenity is deleted and delay goes to zero. Then, without further operator intervention, the unit starts imperceptibly adding delay back into the program audio, with no program interruption. The delay "safety margin" is automatically rebuilt.

The BD980 features an advanced, de-glitched catch-up system. When objectionable program audio is "dump"ed with the BD980 delay catchup is fast and audio quality is clean. Contributing to the unit's superb audio quality is the 16-bit linear PCM design and 50 kHz sampling rate. Frequency response extends to 20 kHz.

Two independent stereo channels of delay are standard. Maximum delay time is an unprecedented 10 seconds. Delay time can also be manually selected with resolution to one millisecond. A delay max switch permits instant return to maximum delay. "Ramp to Zero" and "Wait & Exit" modes automatically get you in and out of delay — perfect for busy drive-time shows.

The BD980 is also the first and only broadcast delay to feature time compression capabilities.

**BD980 Broadcast Delay (20kHz, stereo)**

*Let Harris Allied assist you with the world's most advanced broadcast delays.*

**BD1002 Digital Program Delay**

Eventide's BD1002 Digital Program Delay is an easy way to produce any kind of live television without risk. This solid state RAM based device delays both the audio and video portions of your program giving you a one to twenty second "cushion" between the live action and transmission so you can easily prevent any objectionable language from going out over the air.

**Usages:**

- **Courtrooms** — Most judges mandate delayed broadcast to protect privacy of key witnesses.
- **Sports** — Instant replays and alternate camera angles can be triggered instantly from RAM.
- **Call-in** — Mute objectionable utterances before they offend your audience.
- **Award Shows** — Keep publicity-hungry celebrities from polluting your airwaves with "shocking" language.
- **News** — Delay live interviews and remotes to retain final control of content.
- **Shopping Channels** — Keep potentially offensive calls from ever reaching the air.

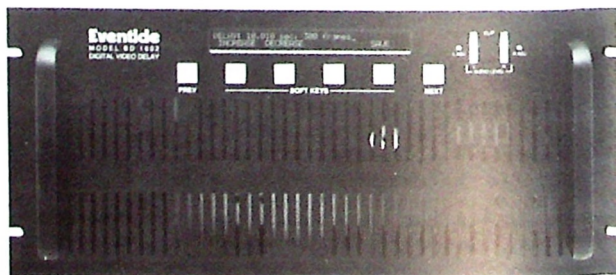

**Trak★Star 2 / Trak★Star 8**

Trak★Star is Arrakis' popular solution to the specific needs of radio stations for digital waveform editing. Trak★Star 2 provides long form two track editing and Trak★Star 8 is a sophisticated 8-channel multitrack mixing and editing software package. Both software packages run on a standalone Trak★Star editor or in conjunction with a DigiLink workstation.

Multiple Trak★Star workstations may be networked for transfer of audio files or schedules between and among each station.

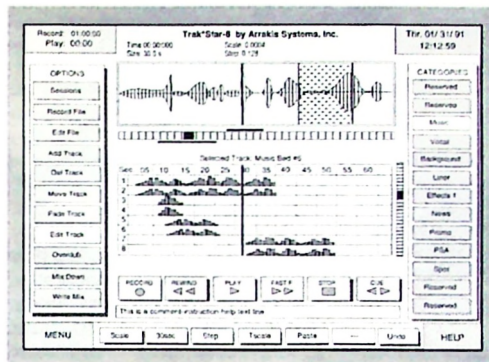

DIGITAL AUDIO LABS

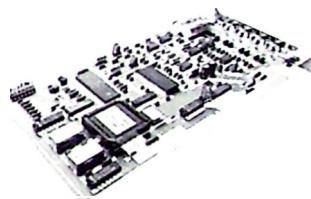
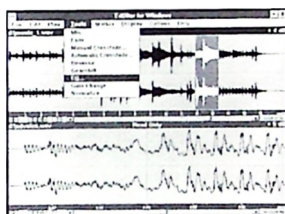
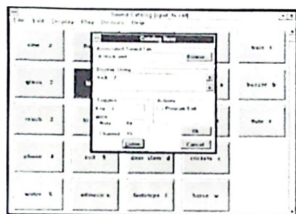

**EdDitor For Windows**

The EdDitor™ for Windows has professional editing capabilities, sample-accurate stereo waveform editing, MIDI and SMPTE triggering and multimedia compatibility. The EdDitor has unusually fast cut-and-paste operations and split-screen editor for easy and precise voice-over and sound effects layering. Call for details.

**CardD™ Stereo Audio Card**

For the ultimate in sound quality, run the EdDitor with the CardD™, the Digital Audio 16-bit stereo audio card. Call Harris Allied today for information on the complete professional desktop studio enhancements.

ROLAND

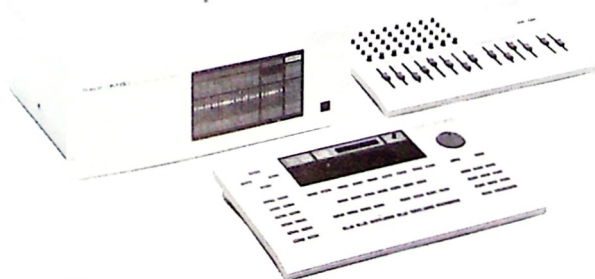

**DM-80 Digital Audio Workstation**

The Roland DM-80 is the most advanced digital audio workstation on the market, providing a professional digital recording system and offering a choice of user interface. Available with 4 and 8 track recorders. On 8 track models, two pairs of digital inputs are included. The DM-80 utilizes a 32-bit internal data path and 24-bit signal processing. For flexibility and control add the DM-80-F Fader Board.

**RAP-10/AT Digital Audio Producer**

The Roland RAP-10/AT audio producer is the digital audio and MIDI sound card with software that becomes a digital recording studio on your desk. The RAP-10/AT provides synchronized playback and recording; quality reverb and chorus for digital audio and MIDI parts; 2 tracks of digital audio plus a 16-part Sound Canvas™ General MIDI synthesizer.

*Certain products not available in some areas.*



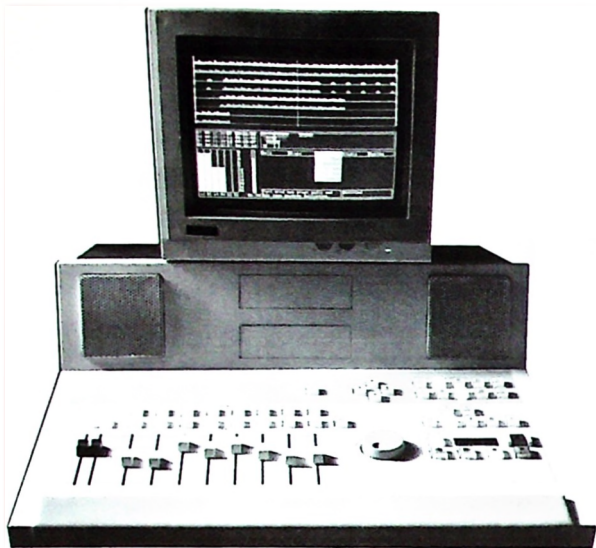

### DSE 7000 Digital Editor

Orban's DSE 7000 has revolutionized the way radio stations produce commercials by making the process faster and easier. This changes everything!

The DSE 7000 is the first fully digital production system with all the familiar analog controls and functions. And, you don't need to be a computer programmer to take advantage of the DSE 7000's powerful features. It's an audio system that just happens to use lightning-fast RAM for editing, massive hard disk storage for archiving and creating your own sound library, and an easy-to-understand display.

Anytime you don't know exactly what to do, you'll find all the answers you need by just pressing "HELP."

Everything about the DSE is designed to be fast and familiar to anyone in radio. Even the color monitor is a simple, visual reference. So, rather than making you jump through hoops, the DSE adapts to you.

A steady stream of software updates and upgrades enhance the system without changing the basic operation and with this kind of digital technology you can produce the highest quality digital spots in one-third the time. And that's what it's all about.

#### The Digital Workstation

The DSE 7000 combines three powerful components into a system that fits where any professional tape recorder would. The controller console is designed for maximum speed and simplicity. A tape-like scrub wheel simplifies cueing and editing. Dedicated buttons are logically placed for track selection, tape motion control and editing. Smooth, responsive slide controls make mix-down and monitoring easy.

RAM-based editing gives you instant access to audio, while disk and DAT options give you up to 8 hours of on-line storage and unlimited off-line storage.

The color monitor displays all the information you need on one screen. At the top you see what's happening on all 8 tracks. Below are all your levels, remaining recording time and fast menu options.

## DSE 7000 THE NEW SPEED OF SOUND

The Digital Sound Editor from Orban

#### Technical Features

- Ten channel digital mixer including level, pan, echo send/return, track bounce and solo functions.
- Time-slipping, copying, moving, instant backtiming, swapping and erasing of audio, with the ability to undo anything.
- High and low speed play with scrub wheel for reel rocking functions.
- Vari-speed for squeezing audio.
- Autolocator with return to beginning, end, last recording point and up to 14 locator points.
- Remote control and status connector for play/record/stop and other functions.
- Automatic saving of audio, mixer settings, locator points and even last UNDO.

#### Audio Specifications

- Digital Audio Format: 16-bit linear PCM.
- Frequency response: 20Hz-15,000Hz,  $\pm 0.5$ dB (32.0kHz sample). 20Hz-20,000 Hz,  $\pm 0.5$ dB (44.1kHz sample with optional Dual-Rate Module).
- S/N Ratio:  $\geq 90$ dB unweighted, over full bandwidth.
- Total Noise + Distortion:  $< 0.005\%$  at 40Hz at full level.  $< 0.004\%$  at 40Hz at 30 dB below full level.

#### System Specifications

- RAM: Options range from 4.4 minutes (1x16 MB card) to 7 minutes (4x64 MB cards).
- Disk: Options range from 1 hour (210 MB) to 8 hours (2 GB) of on-line audio.
- Size: System unit 26"Hx8"Wx17"D  
Display Unit 14"Hx14"Wx15"D  
Controller 3"Hx25"Wx15"D
- Shipping Weight: 129 lbs.



# A 60 Second Look at the Last 25 Years in Commercial Radio.

*The DSE 7000.*

*The fastest  
digital  
workstation  
for radio  
production.*

*Simplest to use.*

*And still the  
best way to get  
sixty seconds  
of history  
on the air.*

*Orban.*

*Celebrating*

*25 years*

*in broadcast.*



*The Eagle has landed...New York  
State Thruway is closed, man...And  
Pepsi's got a lot to give...Wake Up,  
Maggie, I think I've got something to  
say to you...Peace is at hand...Bye, Bye,  
Miss American Pie...I am not a crook...  
I shot the sheriff...Plop Plop, Fizz Fizz...  
Tramps like us, baby we were born to...  
Hi, I'm Jimmy Carter...Ah, Ah, Ah, Ah  
Stayin' Alive, Stayin' Alive...No  
Nukes...Are you better off than you  
were four years ago?...Have a Coke  
and a smile...She's got, Bette Davis  
eyes...Where's the beef?...Beat it!...Beat  
it!...Four more years...What's love got to  
do with it?...Gorby! Gorby! .We are the  
world, we are...The ultimate driving  
machine...The Dow fell over 500 points  
today...I'm Tom Bodette for Motel  
Six...we'll leave the light on for ya...  
That's "potatoe" with an "E"....You got  
the right one baby, Uh Huh!*

There is just no faster way to slice through 25 years of radio, or your next sixty seconds, than the DSE 7000. *The New Speed Of Sound.*

**orban**<sup>®</sup>

**H** A Harman International Company

© 1994 ARG Acoustics, Inc. Orban and OPTIMOD are registered trademarks of ARG Acoustics, Inc.

All other trademarks are property of their respective companies. 1525 Alvarado St., San Leandro, CA 94577 USA Phone 1-510-351-3500 Fax 1-510-351-0500. In Canada contact: 514-395-8966

AIRCORP

**AirCart MO Cartridge Tape Machine**

The AirCart MO presents the convenience and common sense of broadcast carts with none of the problems. So, for those operators who seek to maintain all of the positive attributes of cartridge tape machines while eliminating the obvious problems, the new AirCart from AirCorp Systems is the total solution. Commercials, liners and music programming are recorded on magneto/optical discs. These protected 3.5" discs will hold in excess of 10 minutes of non-compressed stereo audio. Discs are re-recordable up to one million times. Take advantage of perfect, linear digital audio in a removable format, call today about the AirCart MO.

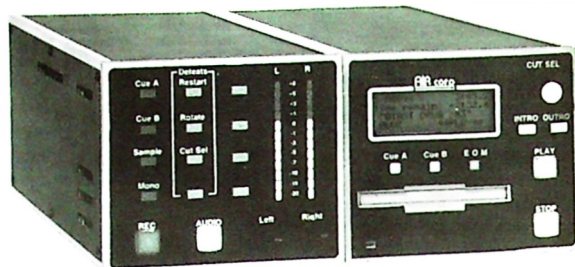

ALESIS

**ADAT® Digital Audio Recorder**

The Alesis ADAT® is a digital multitrack tape recorder that records eight independent audio tracks onto S-VHS® tape with approximately 40 minutes recording time. Digital audio is recorded with compact disc quality, using 64x oversampling Delta-Sigma converters, with linear 16 bit quantization and a sample rate of 48kHz (variable from 40.36kHz -50.85kHz). This results in a 92dB dynamic range, crosstalk better than -90dB, flat frequency response from 20Hz to 20kHz (±0.5dB), and low distortion (.009% THD + noise at maximum modulation). Gapless and seamless punch ins and outs are achieved using digital crossfading. Uses only three standard spaces when mounted in a 19" rack.



DENON

**DN-990R MD Cart™ Recorder and  
DN-980F MD Cart™ Player**

Denon, creator of the broadcast standard CD Cart Player™, introduces the DN-990R MD Cart™ Recorder and the DN-980F MD Cart™ Player. Both the DN-990R and DN-980F Mini Discs are designed specifically for broadcasters who want all the benefits of the CD Cart™ Series and the highest standards of operability, reliability and efficiency. Mini Disc provides a universal, removeable, digitally-recorded format that addresses the important function of antiquated NAB Carts. Erase and re-record capabilities encourage MD's use for commercial/spot production and playback. Thirteen character time/code/name/message 24-segment peak level meter & overload. EIA 3 units high, 3 units across in 19" rack. 5-<sup>1</sup>/<sub>16</sub>"Wx5-<sup>1</sup>/<sub>16</sub>"Hx15-<sup>3</sup>/<sub>16</sub>"D.



DN-990R



DN-980F



EVENTIDE

**VR240 Digital Audio Logger**

The VR240 Digital Audio Logger's digital technology drastically reduces the tape cost and storage requirements of conventional reel-to-reel loggers. The VR240 records up to 10 full days of on-air programming — music, news, weather, DJ chatter, topical discussions and advertising on a single R-DAT cassette. Frequency response of 200-3000 Hz with zero wow and flutter and 50 dB S/N are ideal for logging applications. The unit can be upgraded instantly to 16 input/output channel capacity by plugging in an optional 8 channel I/O board or to 24 channels by adding two boards. Time code is standard. An optional second deck allows simultaneous record and play.





**Each tiny tape logs  
a full week of audio.**

**Eventide®**  
VR240 Digital  
Broadcast Logger

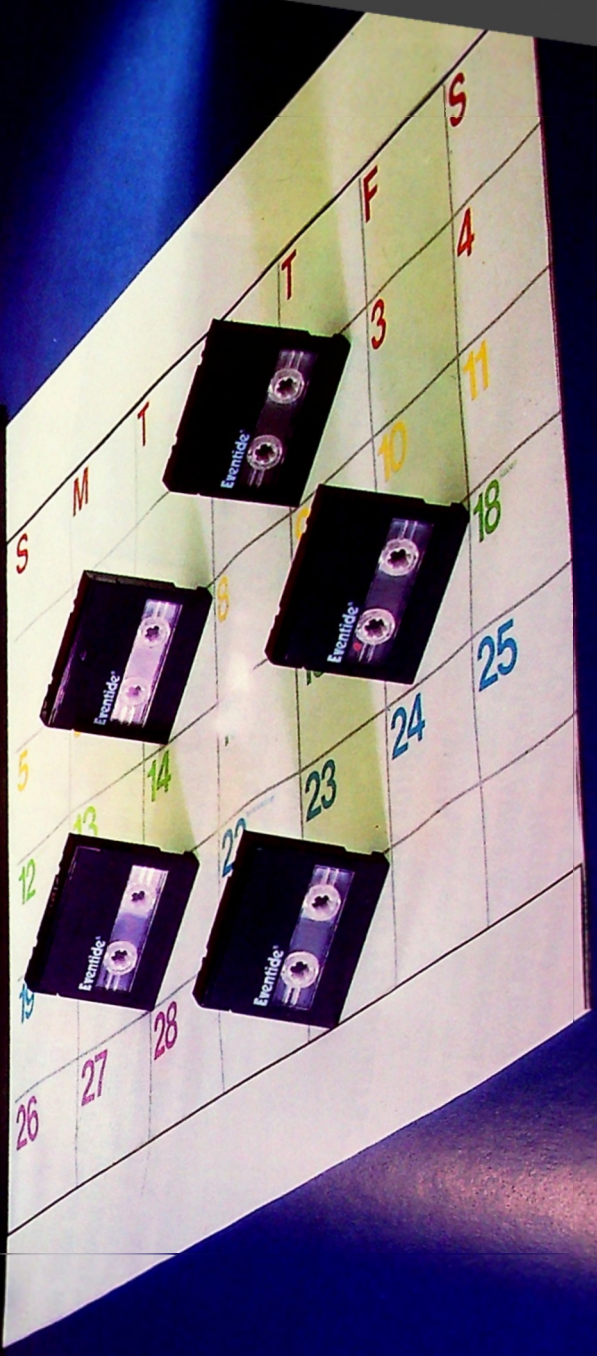

FIDELIPAC



**DCR1000 Series Digital Cart Machine**

Fidelipac's DCR1000 provides CD quality with familiar operational characteristics and low cost, 3 1/2" high density floppy discs. A 13MB disc provides over 5 minutes of stereo audio with 15 kHz bandwidth. A standard 2MB floppy holds 60-second commercials. All physical characteristics are identical to analog machines, without the maintenance hassles. Features include: built-in countdown timer, clock/calendar, an RS232/422 port for machine control or logging output and a port for standard PC keyboard plus much more.

**DCR1000 Series Accessories:** Accessories include diskette storage racks, for table top or wall mount; diskettes, diskette labels and a PC AT keyboard with instruction template.

FOSTEX



**D-10 DAT Master Recorder**

The new Fostex D-10 Digital Master Recorder features Instant Start, Auto Cue, Auto Rehearse, RAM Scrub, Auto Record, Jog/Shuttle and No Copy Guard. The D-10 has up to 799 Program Number tape locations that can be recorded and played back. Numbering can be automatically or manually controlled and re-numbering and skip programming are also possible. The D-10 has professional features and functions that will appeal to broadcast engineers.



**RD-8 Digital 8-Track Recorder**

The new Fostex RD-8 is an 8-track recorder that uses 16-bit A to D conversion and 64 times oversampling for better-than-CD sound quality. Features include: on-board chase/lock (SMPTE/EBU) time code synchronizer, selectable sampling: 44.1 or 48kHz, RS-422 port, track slip: up to 170msec, pull-up and pull-down. The RD-8 has complete compatibility with all hardware and software in the ADAT Group.

HENRY



**DigiCord Solid State Recorder**

The Henry DigiCord is a general purpose digital audio recorder that can record over 5 minutes of audio. Up to 16 separate messages can be recorded for random-access playback. DigiCord is ideally suited for: network news delay, EBS logging, remote station or translator ID. Messages can play once-only or repeat continuously, be recorded from a mic or tape deck and can be remote controlled. Backup battery prevents memory loss during AC power failure.

*Confused about digital audio recorders?*

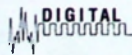

*The digital audio specialists at Harris Allied are trained on all digital products featured in this catalog. Call your Harris Allied professional today. You can rely on their expertise, and be confident you'll get the best deal.*

---

## ITC

---

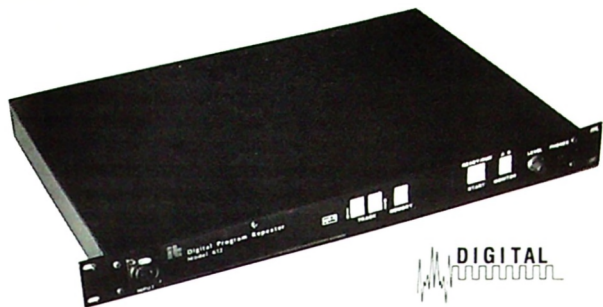

### DPR 612 Digital Program Repeater

The ITC DPR 612 is a solid state digital audio program (message) repeater capable of satisfying every demand for frequent, consistent and reliable reproduction of audio programs stored. All solid state means components won't wear out with unlimited number of play-backs. Two active balanced outputs allow simultaneous and independent reproduction of two programs. Convenient headphone output.

---

## OTARI

---



### DTR-7 DAT Recorder

The DTR-7 Digital Audio Tape Recorder is designed specifically for professional applications and conforms to the basic R-DAT format established by the EIAJ/DAT conference. The DTR-7's professional features include balanced analog inputs/outputs, AES/EBU and S/PDIF digital inputs/outputs, one bit A/D and D/A converters, 48/44.1/32 kHz sampling frequencies, and a standard optical remote control, 20 segment digital meters with peak hold function, 32 kHz LP mode allows twice the recording time on a standard tape. Full index writing function for Start IDs, Program number codes and END codes.



### DTR-90T DAT Recorder

Another full-featured professional R-DAT machine from Otari is the DTR-90. Highlights include 4 head design with 10,000 hour head drum bearing life, standard 37 pin Parallel I/O, internal chase synchronizer with time code generator reader, quick start buffer memory option, edit memory option and CB149 editor option. Link two DTR-90T machines with the optional CB149 R-DAT editor for high-precision digital audio electronic editing. If DAT is in your plans, fax or phone Harris Allied for complete information.

*Call Harris Allied for information on Otari's new Mini Disc*

---

## RACOM

---



### 1700 - Tele-Vote

The Racom 1700XT - Tele-Vote is a multi-channel voice storage and automatic voting system. The caller listens to a greeting message then enters a response on a telephone keypad to vote. Voice storage is accomplished by digitizing incoming audio and storing it in electronic semiconductor memory. Up to 6 lines available with multiple unit linking. Additional options available.



### 1200L Digital Message Announcer

The Racom 1200L Digital Message Announcer digitally records your audio message (no tape, no moving parts, no maintenance); has up to 8 minutes of record/playback time; automatically answers telephone line and plays recorded message to the caller. Takes just minutes to install. With digital recording your message never "wears out."

*Certain products not available in some areas.*

**HARRIS ALLIED**



**SV-3700 DAT Recorder**

The SV-3700, Panasonic Digital Audio Tape deck is designed specifically for professional applications. New DAT technology offers CD sound quality together with the full recording/playback capability of a cassette deck. Convenience is outstanding, with direct access, skip, and programmed play functions, not to mention ultra-fast rewind/fast-forward operations. This is possible thanks to rotary head technology and time/program indexing signals that are recorded together with the audio information. Rack mounting hardware is included.



**SV-4100 Digital Audio Tape Deck**

The new SV-4100 Pro-DAT is targeted at the on-air broadcast, live-performance, theatrical-sound, recording and production studio markets. Users that require instant playback, A-Time Cue Search and accurate synchronization to external video sync or word clock during digital transfers. Features include: instant start mode; accurate PNO/Cue assignment; external sync capability; 5 programmable cue locations; software-enhanced digital interface; programmable output level control; optical plus AES/IEC digital I/Os and enhanced system diagnostics.



**SV-3900 DAT Recorder With Remote**

The Panasonic SV-3900 Pro-DAT Recorder provides outstanding record/replay quality and comprehensive serial remote control via industry-standard serial protocols. The SV-3900 is designed specifically for remote control applications, using either the full featured SH-MK390 Remote Controller or external computer interfaces. Select simultaneous control of up to 32 individually addressable machines connected on an ES-bus, local area network or single machine/controller combinations using P2 protocols. Like Panasonic's SV-3700, the SV-3900 DAT recorder combines performance with a multitude of great features. The mechanical design of these two DAT recorders is virtually identical, however, the SV-3900 has an optional remote control. Rack mounting hardware is included.

**Optional SH-MK390 Remote Controller:**

This remote control, model SH-MK390, operates on a computer style RS-422 bus and communicates with the SV-3900 via industry standard, switch-selectable ES-Bus or P2 Protocols. The SH-MK390 adds important new programming features to a group of SV-3900 including multi-machine programmable playback and mass tap duplication. As many as 32 DATs can be wired in a network configuration.

**Software Developer's "ToolKit"**

The Panasonic SV-3900 software developer's "ToolKit" consists of a set of powerful utilities designed to streamline the development of application-specific software for the SV-3900 Pro DAT. Software for the SV-3900 Pro-DAT Recorder is available through Harris Allied, call today for details.

SONY

**DTC-A7 DAT Recorder**

Sony offers a new value in professional standard rack mounted DAT recorders, the DTC-A7. The DTC-A7 offers digital recording at 32, 44.1 and 48kHz sampling rates. Long play mode recording allows twice the recording time at 32kHz (up to 4 hours on a T120). With 2 direct drive motors and 1 DC motor, the DTC-A7 offers a transport ruggedly prepared for professional use. Back tension control and a built-in head cleaning roller are features not typically offered in this price range. Additional features include Start IDs, Date function, Digital Peak Margin Display. The DTC-A7 is supplied with rack ears and a wireless remote.





**MDS-B2P MiniDisc Cartridge Machine (Play)**

The MDS-B2P uses a 2.5 inch MiniDisc utilizing a new digital audio compression technology called ATRAC (Adaptive Transform Acoustic Coding). This provides 74 minutes of clear digital high quality audio. The unit features quick random access and track editing functions, memory start cueing for rapid playback, informative FL display, single and continuous play capability and EOM. The MD has a durability far superior to tape based systems. Each unit weighs 11 lbs. (5kg) and measures 5 $\frac{5}{8}$ Wx5 $\frac{1}{4}$ Hx14 $\frac{1}{8}$ D (142x132x375mm) and 3 (side-by-side) can be mounted in standard 19" rack.

**MDS-B1 MiniDisc Cartridge Machine (Record/Play)**

The MDS-B1 has all the features of the MDS-B2P plus unique record capability which incorporates a search for blank disc space before recording, thus avoiding accidental erasure of prerecorded material. Up to 74 minutes of recording time is available. A supplied remote controller enables end user data to be stored on disc — such as track titles, end cues, date, etc. and can be shown on the FL display. Quick editing is provided by rewriting the TOC disc area through four functions: COMBINE, DIVIDE, MOVE and ERASE.



**NT-1 Digital Micro Recorder**

The NT-1 Digital Micro Recorder is a new 12 bit non-linear digital recorder that uses a cassette the size of a postage stamp. Its ultra compact size, superb sound quality and long battery life make it the ideal device for recording conferences, interviews, lectures, news events and other special applications. Compact size and light weight allow recording almost anywhere with up to 7 hours using a single "AA" alkaline battery. Weight: 5.2 oz. (147 g). Dimensions: 112.9x231x55.2mm. (4.4"x9.1"x2.2").



**PCM 2300 DAT Recorder**

The Sony PCM 2300 professional DAT recorder is a compact, cost-effective recorder which combines all the basic audio functions with performance. Ideally suited for simple recording and playback applications. This unit is 19" rack mountable featuring date function, easy-to-read display, long recording and playback duration, flexible interfacing, adjustable fader, oversampling converters and optional remote control.

**PCM-2700A Audio Tape Recorder**

The PCM-2700A, an affordable professional DAT recorder from Sony, includes high quality audio performance and convenient operational functions. Extensive use of the latest devices, such as second general LSIs and a 1-bit pulse D/A convertor, provides advanced digital audio signal processing techniques. An extremely stable and precise tape transport system is assured by a 4DD (Direct Drive) motor mechanism controlled by a servo system. The perfect choice for a broadcast station or recording studio.





### TCD-D7 DAT Walkman® Digital Audio Tape Player/Recorder

The Sony TCD-D7 is a full-featured DAT player/recorder with long play mode for up to 4 hours of recording and playback. Features include: built-in 1-bit D/A converter with 8x oversampling for low noise and extended frequency response. Digital coaxial and optical input and output maintain the highest signal purity for recording and playback of digital sources. Automatic recording level control is switchable on or off, and lets you select automatic volume levels for voice or music recording. Weight 1 lb. 1.5 oz. Dimensions: 12¼"Wx1½"Hx3½"D.



### TCD-D10 PRO II

The TCD-D10 PRO II is Sony's second generation of D10 adding a variety of useful functions. These include the addition of Absolute (A-time) recording and playback, RF End search and improved CUE & Review. Other features include error code display, SCMS ID6 indication, recorded time display, SCMS playback and improved digital I/O with AC/DC operation. The TCD D10 PRO II is on eof Sony's smallest DAT recorders weighing only 4 lbs. 7 oz., a compact design for professional applications. This unit has easy, precise operation features with quick and easy maintenance when necessary. 253x55x191mm (10"x2.25"x7.625").



### DA-30 Digital Recorder

The DA-30 is an affordable, full function rack-mountable DAT recorder/reproducer stereo deck which carries on Tascam's tradition of having the best sounding DATs. The DA-30's analog-to-digital converters use Delta-Sigma modulation and 64-times oversampling while the digital to analog converters feature 18-bit technology with eight-times oversampling. Combined, this results in the achievement of a S/N ratio in excess of 94 dB. Other key features include AES/EBU digital I/O, a full-function programmable remote control, start ID positioning, head room margin display and +4 dBm balanced inputs and outputs plus -10 dBV unbalanced ins and outs.

The DA-30 offers professional-quality recording capabilities: 48kHz, 44.1kHz and 32kHz sampling frequencies; 15-pin parallel I/O port allows the DA-30 transport to be controlled by external equipment; +4dBm XLR-type balanced analog inputs and outputs as well as -10dBV RCA connections.



### DA-60 Digital Recorder

The DA-60 from Tascam sets new standards for ease of operation, features, sound quality and affordability. It is designed to meet the needs of the audio professional in film, audio for video post production as well as audio mastering. Features include: four head, configuration for off tape confidence monitoring and recording; front panel access; ram buffer that gives 2 seconds of ram for instant start; auto cue that will start play at the first frame of audio; copy protection, select copy protection through front panel menu and auto ID. Other features include the SY-D6 optional plug-in chase lock synchronizer card that also has a SMPTU/EBU time code reader/generator. The SY-D6 also provides for Video Sync, locking the transport and T/C generator.

Since the DA-60 is designed for use in professional recording and production environments, there is an AES/EBU digital interface that allows direct connection to other digital audio equipment supporting this standard, and the DA-60 will function perfectly in just about any system.

## TASCAM

### DA-88 Multitrack Recorder

The DA-88 digital multitrack from Tascam is designed to deliver today's digital recording technology to the project studio and post production environments. The DA-88's Hi-8 format allows up to 100 minutes of recording time — enough for an entire CD project, feature film or video project. Main features of the DA-88 include Tascam's rugged and proven professional transport; large transport buttons; large jog/shuttle wheel for easy locating; no formatting of tape before recording and optional SY-88 Synchronization Board which provides SMPTE synchronization, both as master and slave, video sync, a 9-pin RS-422 port and MMC (MIDI Machine Control).

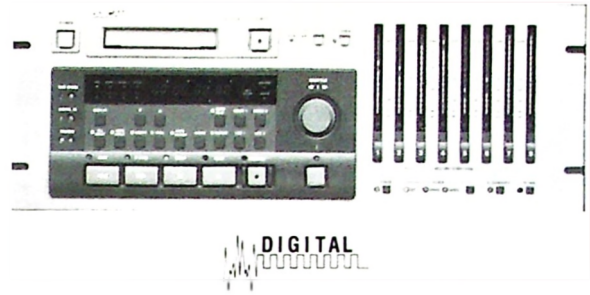

## DAT TAPES

**DAT cassettes available in 60 minutes, 90 minutes and 120 minutes.**



### Ampex

Ampex is dedicated to offering the most complete line of reliable, high quality accessories including a professional digital audio tape. Contact your Harris Allied representative today for the DAT that gives you maximum performance. Ask about bulk packages.

DENON  
R-120DT  
DAT

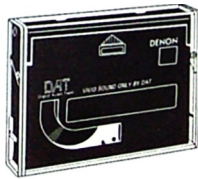

### Denon

The Denon cassette digital audio tape uses a formulation containing ultra-fine metal particles to achieve outstanding electromagnetic conversion properties and particle uniformity that are superior to that of metal cassette tape. Advanced coating and surface treatment prevent errors due to dropouts which are reduced to minimum levels.

***As a professional,  
you know the difference.  
That's why Harris Allied  
supplies only  
professional accessories.***

*Certain products not available in some areas.*

**HARRIS  
ALLIED**



### Panasonic

Panasonic DAT cassette tapes deliver the superior sound quality inherent in DAT technology, with up to 400x high-speed searching. Along with small cassette size and up to 2-hour recording time, this series of master-quality tapes offers a performance worthy of the new digital age.



### Scotch 3/M

Scotch 3/M digital audio tape cassettes provide professional sound quality and channel separation equal to compact disc recording. No tape hiss or modulation noise and no sound distortion from recording level fluctuations. Depend on Scotch 3/M for high speed tracking, built-in error correction plus the latest in technology.

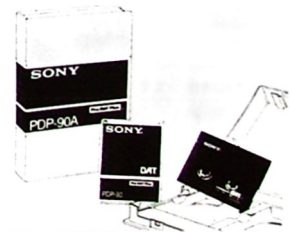

### Sony

Sony's DAT tapes revolve around professional quality, digital performance. Outstanding features include improved playback output over current professional DAT tapes; superior block error rate; heat resistant shell; anti-static lid that reduces dropouts and a new wide-window design and larger label area.

## 360 SYSTEMS



### AM-16B Audio Routing Switcher

AM-16 System Architecture: The AM-16/B Audio Crosspoint Switcher is a self-contained master switcher that supplies everything needed in a 16 input, 16 out system. Full front panel control and display facilities are included on the AM-16/B, which can be configured for 16x16, monaural or 8x8 stereo operation. The AM-16 series may be controlled remotely by the optional AM-16/R intelligent remote controller. The AM-16/E Expander provides 16 additional channels when connected to an AM-16/B. Harris Allied has complete information and comprehensive spec sheets.

## APHEX



### 120A Audio Distribution Amp

The Model 120 is a high performance audio distribution amplifier with a single high impedance input and four low impedance outputs, all electronically servo-balanced. Each output has its own amplifier and level control for maximum versatility and isolation. The sturdy steel chassis may be used stand-alone or rackmounted.



### Modular 1x6 Distribution Amplifier Model 8126

The Aphex Systems Model 8126 has transformerless, audiophile performance, complete interface security of transformers without sonic degradation, servo-balanced, RF suppressed input  $\pm 15$ dB gain range, remote/local switching of A/B source, six servo-balanced output stages, fuse and diode protected from back voltage on each leg. Space saving one 3U rack frame fits 11 modules.

## ATI

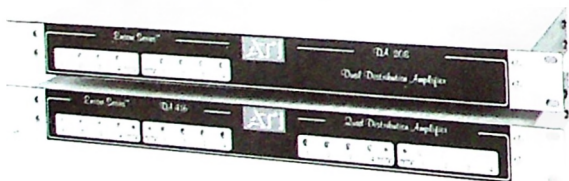

### DA208 & DA416 Audio Distribution Amp

Two or four inputs, each driving four individually adjustable, active balanced outputs gives you twice the channels for the price, twice the performance in most applications. Need more outputs? Just parallel inputs for up to 1 x 16 operation. Drive everything from balanced 600 ohm lines to Hi-Z IHF phono jack inputs without matching pads or noise compromises. Transparent performance, RF protected.

DA208-Dual 1x4  
DA416-Quad 1x4



### DA1000 & DA2008 Audio Distribution Amp

A single, high output, active balanced driver per channel is resistively split into 4 or 8 outputs each, all driven at precisely the same level. Up to +24 dBm balanced in and out. Features output clipping LEDs and a headphone/metering jack in a half rack package that you can mount singularly or side-by-side in only 1 3/4".

### DA1008 & DA2016 Audio Distribution Amp

Easily match differing line level requirements with these high output DAs with 8 or 16 individually adjustable outputs. Active and transformer balanced outputs at +22 or +30 dBm. An LED meter with three selectable 0VU settings allows you to set nominal line levels and monitor peak headroom. Includes input clipping LEDs and a boosted headphone output. Our top-of-the-line unit for your most demanding applications. Rack mounts in only 1 3/4".

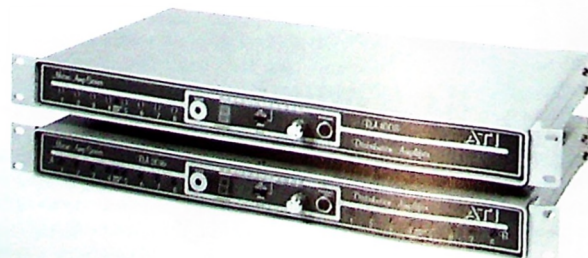



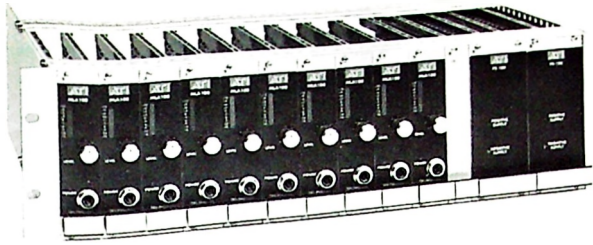

**DA10,000 Audio Distribution Amp**

ATI has expanded its line of Modular Systems to include plug-in microphone and line amplifiers available as single and dual units with or without metering, with transformer or active balanced output and optional VCAs with remote DC gain control. System 10,000 plugin's all use the same rack frame as our original module types. Now, over 40 interchangeable microphone, line and audio DA modules available to mix and match precisely to your requirement.



**PB2X8 Press Box**

The PB2X8 Press Box eliminates the mass of microphones crowding the podium with a pair of mics driving eight transformer isolated balanced output channels. Each output has a convenient combination of both an XLR and either a 1/4 inch or 3.5mm TRS output jack. Use the PB2X8 as a stereo 1X4 DA with Mic or line inputs.

**AUDIO-METRICS**

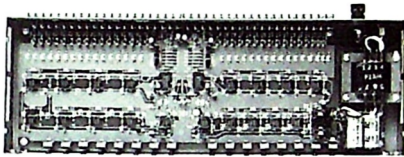

**DA8x2 Distribution Amplifier**

The Audiometrics distribution amplifier combines solid state electronics and functional flexibility into one small package. A single high quality audio op amp provides each balanced output, and individual gain adjustments for each channel. Excellent isolation is provided between outputs. Audio sources can be routed to multiple locations with various level requirements and impedances.



**DA-8000 Audio Distribution Amplifier**

The Audio-Metrics DA-8000 is the highest quality audio distribution amplifier in the broadcast industry, providing "transparent" audio distribution, extremely low distortion and very high signal-to-noise ratio. The frequency response is virtually flat from 10Hz to over 50kHz. The DA-8000 has two balanced input channels capable of receiving audio levels from -55 dBm to +8 dBm. Each input channel is independently adjustable for audio level. Using DIP switches, front panel LED indicators and a trim-pot, the input level can be set to exactly match the source audio level.

**AUDISAR**

**Audio Transformers**

The Audisar 9000 series audio transformers provide many unique problem solving solutions for the broadcast and industrial audio user. For example the 9K-600-6 in many cases will directly replace an expensive distribution amplifier. Highest-quality standards are manufactured into each unit which is individually hand-made to ensure reliability and consistency of performance. Every core assembly is varnish impregnated for protection from moisture and corrosion. Both open frame and shielded units are available.



PART NUMBER	TYPE/USE	FREQUENCY RESPONSE <sub>2</sub>	MAX OPER. LEVEL <sub>3</sub>	IMPEDANCE, OHMS
9K-600-2	1:1 ISOLATION	17Hz~50KHz±0.5dB	+24dBm	600:600Ω
9K-600-3	1:2 ISOLATION SPLITTING	17Hz~50KHz±0.5dB	+24dBm	Z in:600x2
9K-600-6	1:5 ISOLATION DISTRIBUTION	17Hz~50KHz±0.5dB	+24dBm	IMP IS CONFIGURATION DEPENDENT (NOTE 4)
9K-600-2SF	LINE LEVEL OUTPUT MATCHING	20Hz~50KHz±0.4dB	+18dBm	600:600Ω
9K-600-15KP <sub>1</sub>	SHIELDED INPUT, LINE LEVEL, ISOLATION	20Hz~50KHz±0.25dB	+20dBm	600:15K (R <sub>1</sub> =27KΩ)
9K-600-2P <sub>1</sub>	1:1 LINE LEVEL SHIELDED INPUT	20Hz~20KHz±0.4dB	+18dBm	600:600Ω

- 1. Denotes octal base, plug-in type
- 2. Measured at +10dBm except 9K-150X2-150P re 0-0.775Vrms
- 3. Measured @20Hz, except where noted.
- 4. Insertion loss = 5dB all sec loaded 600Ω

Certain products not available in some areas.



## BROADCAST DEVICES



## CDS-200 Composite DA/Switcher

The Broadcast Devices CDS-200 was designed to allow two switchable sources to be distributed to three locations. Sources within the bandwidth of 10Hz to 100kHz such as composite audio, SCA or SAP signals can all be accommodated. Each output of the CDS-200 uses individual output amplifiers for maximum isolation. Level adjustments and switcher controls are conveniently located on the front panel. The switcher has remote control capability.

## BURK TECHNOLOGY

## LX-1 Stereo Switcher

The LX-1 stereo switcher from Burk Technology is designed to improve your control room operation by reducing demands on your air console and eliminating the need to patch for alternate program sources. Outstanding features include: select air program from studio, automation, satellite or tape; control from front panel, studio or remote control; start automation or tape with machine-follow output; eliminate patching for alternate air program sources; mix sources for 2-studio dialog; match IHF or PRO inputs.

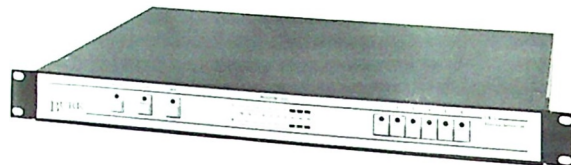

## CONEX



## AS-101 Audio Switcher

The Conex AS-101 audio switcher allows any one of 10 stereo sources to be switched to the stereo output channel. Switching is accomplished by pressing one of the illuminated buttons on the front panel, or remotely, via the remote control connector on the rear panel. Several remote control devices may be connected in parallel, and all will indicate the selected channel. The **AS-401 Remote Control** units are simple, inexpensive and easy to connect. Multiple remote control units may be connected to the 7 wire remote control bus.



## UM-33 Cue Amplifier

The Conex UM-33 cue amp is a stereo, eight channel in, one channel out general purpose cue, monitor, and line amplifier. The cue amp provides the easiest, least expensive, and most compact way of handling a variety of common monitoring, cueing, amplifying, and switching situations in any audio installation.

## DAVTRONICS



MCN 1200



MCN 1210

## MCN 1200/MCN 1210

The MCN 1200 provides a practical interface between newsroom equipment and its operator centralizing and simplifying audio mixing and patching functions. The MCN 1200 solves the compatibility and space problems of separate equipment with one flexible and versatile unit. Essentially an enhanced two-channel mixer, the MCN 1200 has 12 selectable inputs. Also available is the MCN 1210 with 8 selectable inputs.

## EXCALIBUR



### CDA-1 Composite Distribution Amplifier

The CDA-1 from Excalibur Electronics is a 1 in, 3 out distribution amplifier for stereo composite signals. Each output has its own level

control, a front panel accessible 20-turn pot for precise adjustment. Use the CDA-1 to feed your stereo generator to main and auxiliary transmitters, with the third output for test equipment. Other uses include distributing subcarrier generator outputs to multiple transmitters, distributing modulation monitor outputs to multiple subcarrier monitors and/or test equipment, and distributing composite signals at repeater or relay sites.

## GENTNER

### RDA Routing Distribution Amp

If you're looking for an audio distribution amplifier that can meet your changing needs, the Routing Distribution Amplifier (RDA) is the answer. The RDA's unique eight input design gives you uncompromised versatility and flexibility in your installation. Instead of a limited number of inputs (usually one or two) and a fixed number of outputs (usually 8 per input), the RDA has eight (8) inputs and twenty-eight (28) outputs. Any input or any combination of inputs can be routed to any output. And, because it can be changed easily and quickly, it continues to provide versatility long after installation. 3.5"Hx19"Wx11.2"D. Shipping weight: 13 lbs.



## HENRY

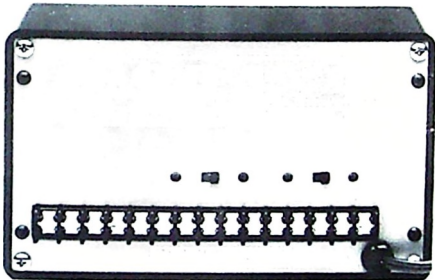

### U.S.D.A.

The Utility Summing & Distribution Amplifier is a unique 2x4 "Mini-D.A." that can be used to combine or split audio signals for distribution. U.S.D.A. has two inputs (one stereo pair) and four outputs (two stereo pairs). It can be used as a 1x4 or 2x4 DA in mono or stereo. Each stereo output can be independently switched to MONO, so that a stereo input can produce a stereo and/or mono output *without* degrading the separation of the input signal. Inputs and outputs can be balanced or unbalanced. Input levels can be -20 to +8 dBm; gain is adjustable to +20 dB. Each output will drive a 600 ohm load to at least +24 dBm.

## ITC

### Audio Switcher

The Audio Switcher from International Tapetronics Corporation is designed to replace patchbays and distribution amplifiers offering a new level of flexibility for handling today's diverse and dynamic multi-programming requirements.

- Reduces lost air time due to faulty or defective patching
- Fewer labor costs for wiring and maintenance
- Eliminates the need for monitor speakers and meters (they are built into the Master Control)
- Compact size reduces rack space requirements
- Saves operator training time

The Audio Switcher includes a keyboard and printer as standard equipment. Once in operation the switcher can provide a hardcopy printout of the system status and log. The most complex routing problem can be solved easily and quickly by referring to the log.

#### Features:

- Fail-safe memory protection in event of power failure
- "Wild Audio" capability for "intelligent" routing
- Versatile salvos for automatic matrix changes
- Built-in security via 4-digit codes
- Master control has a 5-line x 40-character alpha-numeric graphics LCD display, plus four "soft key" function pushbuttons, alarm sensors and real-time clock/calendar.
- Matrix boards are replaceable while the system is in operation

## MODULATION SCIENCES

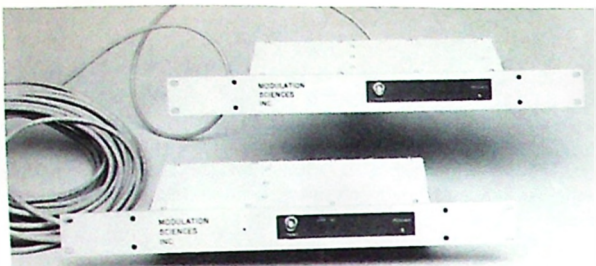

### CLD-2504 Composite Distribution Amplifier

Modulation Sciences' CLD-2504 Composite Distribution Amplifier lets you distribute stereo composite baseband as easily as audio or video plus provides four independent outputs. And with its low-source impedance, cable length is limited only by ground loops. 50 or 75 ohm terminations are equally acceptable. Gain flexibility without disrupting the air chain. Add multiple outputs to your stereo-generator. Ideal for the output of composite aural STL — FM or TV.

## NVISION

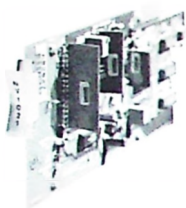

### Model EM1021-00 Distribution Amplifier

NVision's EM1021-00 accepts AES/EBU digital input and provides 7 AES/EBU digital outputs (6 with looping input) on 7-pin Positronics connectors. When used with the EM1030-00 Analog to Digital Audio Converter, the EM1021-00 Digital Distribution Amplifier offers a cost-effective solution to the conversion and distribution of audio signals in only 2 RU of space. The Rack Frame, part number FR1000-00, can hold up to 12 individual modules from the NV1000 Series product line.

## SHURE

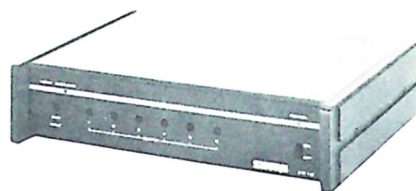

### FP16A Audio Distribution Amplifier

The Shure FP16A is a 1-input, 6-output, compact, self-contained audio distribution amplifier for routing multiple audio feeds without sacrificing signal clarity. The FP16A features a wide-range audio frequency response and extremely low noise, hum and distortion. The FP16A also features link input and output jacks for interconnecting several FP16A's or adding external signal processing equipment.

## RADIO DESIGN LABS



### ST-DA3 Audio Distribution Amplifier

The ST-DA3 "STICK-ON" allows the bridging of any audio line, adjusting the gain, and driving up to three outputs. Each output is driven by a separate amplifier, and is isolated from both the input and from the other outputs. The circuit design allows the input to accept either balanced or unbalanced signals, of either high or low impedance.



### RU-VDA4 Video Distribution Amplifier

The Radio Design Labs RU-VDA4 is part of the group of "Rack-Up"™ products. Rack-Ups™ feature the advanced circuitry for which RDL™ products are known, combined with accessible user-friendly controls and displays. The ultra compact design permits high density installations, with 3 products mounted in a single rack unit.

## ZERCOM

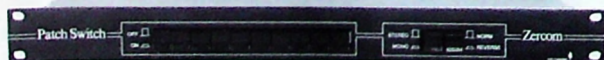

### Model PS-1 Patch Switch

Zercom Patch Switch (Model PS-1) will put an end to your confusing and unsightly patch bay. The Zercom Patch Switch is easy to install and use. Its stereo 10 in and 1 out or 1 in and 10 out configuration allows you to reverse stereo phase and perform stereo to mono summing with the push of a button.

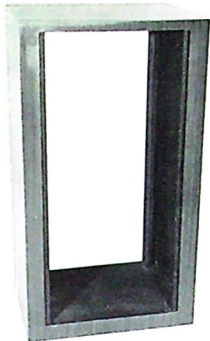

**Equipment Rack**

A-Line rack cabinets are made of 3/4" high-density particle board and covered with walnut, oak, pecan or black laminate. Backs of all equipment racks feature an exclusive snap-out panel for easy access to equipment. Custom heights and colors are available. For overall dimensions add 4" to the panel height, all units are 23 1/4" wide overall, 17" internal depth racks are 18" deep overall. 23" internal depth racks are available, please specify. Optional casters.

For overall dimensions add 4" to the panel height, all units are 23 1/4" wide overall, 17" internal depth racks are 18" deep overall. 23" internal depth racks are available, please specify. Optional casters.



**Record Rack**

Now your music or transcription library can be put in alphabetical or numerical order with these standard or custom size record storage cabinets. Put your studio in order, call Harris Allied today.

Record Rack

Model	Panel Ht	Model	Panel Ht
A/L R100	7"	A/L R107	19 1/4"
A/L R101	8 3/4"	A/L R108	21"
A/L R102	10 1/2"	A/L R109	24 1/2"
A/L R103	12 1/4"	A/L R110	31 1/2"
A/L R104	14"	A/L R111	35"
A/L R105	15 3/4"	A/L R112	42"
A/L R106	17 1/2"		

Model	Record Size	Cap	Shipping Weight
A/L 1000A	7"	1000	145 lbs.
A/L 1500A	7"	1500	200 lbs.
A/L 3000A	7"	3000	250 lbs.
A/L 750B	12"	750	185 lbs.
A/L 1000B	12"	1000	250 lbs.
A/L 1500B	12"	1500	340 lbs.

ATLAS/SOUNDLIER



**Cabinet Rack**

Atlas/Soundlier cabinet relay racks are designed for standard 19" rack panels. Units are complete with removable rear door with lock and louvers, mounting rails, mounting screws and hardware. Available in knocked-down or welded versions. Knockouts and internal louvers are among the exclusive features offered by Atlas/Soundlier.

BEVCO



**Bevco Chair**

Built to withstand years of use, the Bevco chair features an upholstered floating action back attached to a solid steel back brace. The upholstered waterfall seat rotates a full 360 degrees on a solid steel threaded stem. The base is made of heavy gauge tubular steel with an electronically welded footring for added stability and comfort. All metal parts are top-grade baked enamel to resist scratching and chipping. Stock chair includes chrome legs and footring, black frame finish with black upholstery and casters. Shippable via UPS™ and FedEx™.

2200 "Low" Chair . . . adjusts 19"-24". Shipping wt.: 28 lbs.  
 2600 "High" Chair . . . adjusts 24"-29". Shipping wt.: 29 lbs.

Over 350 product lines to choose from - Call Harris Allied today!

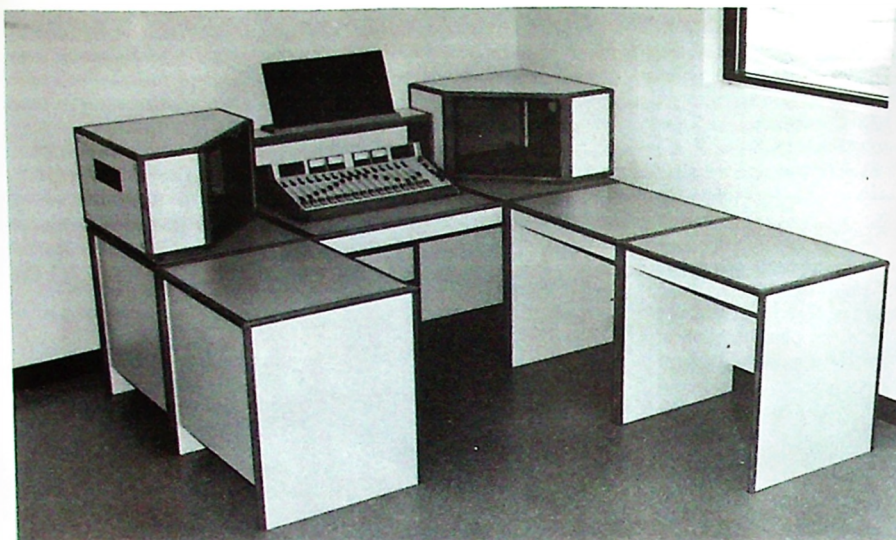

### Modulus II™

Modulus II™ is an economical workstation table design for radio broadcast studios. Modular, flexible, durable and attractive, Modulus II™ is perfect for modern radio broadcast studio applications.

### Modulus II™ Studio Furniture

The Modulus II™ series of broadcast studio furniture is designed to be rugged, attractive, and modular like its big brother "Modulus", yet inexpensive. Modulus II is designed around a basic 24"x30" table that can be converted to a pedestal or rack. Solid oak trim and poly-laminate panels create the ultimate in durability and long

lasting attractive appearance. Quick assembly. In stock for immediate shipment via UPS. Since Modulus II is modular, many configurations are possible with standard components. Talk with us regarding specific dimensions and uses.

### Modulus™

Modulus™ Standard is the most popular line of radio studio furniture sold in the U.S. Modular, flexible, rugged and attractive Modulus™ is the choice of broadcasters from Italy to Tahiti.



### Modulus™ Studio Furniture

Modulus™ is better by design. Until Modulus studio cabinetry, you had to choose: You could pay high prices for strong and durable, well-finished custom-built cabinetry. Or you could pay less, and settle for considerably lower quality. Now there's a third choice, a better choice — Modulus, built by Arrakis Systems exclusively for Harris Allied.

Modulus cabinetry is custom quality but each cabinet need not be custom made. Arrakis has created a unique aluminum post internal frame and wood outer panel system for Modulus. All panels are 3/4" wood polyboard, permanently laminated on both sides at the factory and guaranteed not to delaminate in the field. Access

panels are securely attached, yet easily removed, with quarter-turn fasteners. Modulus's .125 inch thick aluminum post and solid wood panel construction provides superior durability.

All units are immediately available with cream color laminate side panels and dark brown "leather-look" laminate tops, all trimmed in natural oak. Other colors and finishes can be ordered at a moderate up charge. With Modulus, there's no need to compromise on style, quality, delivery and especially — value.

Each Modulus cabinet is shipped knocked-down, via UPS Assembly is fast and easy with just a few hand tools.



## Desk★Star™

- Digital high-tech design
- Supports video monitors, keyboards and kneewells
- Modular design
- Operator, plus 2 interview positions
- Compatible with 1200 Series Arrakis consoles
- WilsonArt brand tabletop laminates
- Easy to assemble

## Desk★Star™

The new Arrakis Desk★Star furniture line is specifically engineered for digital audio radio studios. The line features special designs for compact consoles, interview areas, video monitors, kneewells and keyboards. Desk★Star is a modular approach to studio layout with

five basic building blocks: 1) an "L" shaped console table, 2) a 42" high sloped equipment rack, 3) a 45 degree joining table, 4) a double pedestal cabinet and 5) a 14" tabletop equipment rack pod. Pieces are selected and assembled to desired studio configuration.

## Modulink System™

Arrakis introduced the Modulink concept to help speed studio design and construction time. This system was designed around their 12,000 console and their new 1200 series console. Modulink provides an approach unique to system cabling: this studio can be assembled and tested in the factory or sent to your site as a kit for rapid assembly and installation. Consult with your Harris Allied sales professional for the system that best suits your needs.

*Ask us about storage systems and other accessories for the Arrakis Systems studio furniture.*



Modulink



Modulux Supreme™

## Modulux Supreme™

Modulux Supreme™ is engineered for those studios that require a very special touch. This line of furniture features deluxe oak trim and splashguards, touch latch access doors, oversized 36" deep table sizes, overhead and freestanding racks, and many innovative and attractive new features. Ultra-durable, ultra high quality. Ask for Modulux Supreme.

With Modulux Supreme™ there's no need to compromise on style, quality, delivery or value. All units are available through Harris Allied. Call today, let the professionals plan your next studio.

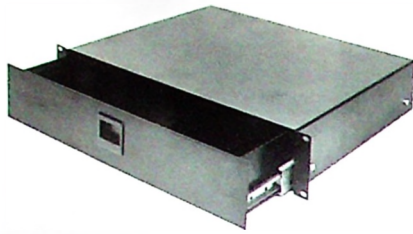

**D2 Rack Drawer**

This rack mounted drawer provides easy storing with a fully enclosed top. Front panel has flush spring-loaded handle, latching upon closing so the drawer stays closed. Full extension ball bearing slides extend the drawer 14" out, for easy access. Inside dimensions are 15 1/2" wide x 14 1/2" deep. Faceplate is .090" thick aluminum brushed and black anodized. Top and body are 16 gauge steel with a black baked enamel finish.

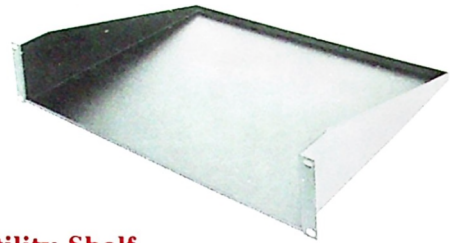

**U2 Utility Shelf**

These utility shelves provide quick and easy rack mounting for equipment that is normally not rack mountable. Constructed of 16 gauge steel with black enamel finish. Two sizes available, but taller equipment may be put in each. The 1 space shelf will support up to 35 lbs., the 2 space will support 50 lbs.

U1-1 1/4"H x 10 1/2" D (1 space)

U2-3 1/2"H x 14 1/2"D (2 space)



*Rackmount Sliding Shelf - Model SS*



*Units In Rackmount*



**Storage Drawers and Rackmounts**

This family of storage drawers and other convenient storage items insures that the contents stay in and dust and cabling stay out. Middle Atlantic supplies the most efficient method of storing everything from compact discs and cassettes to three piece rack shelves to 3 space (5.25") panels punched to accommodate 4 1/2" fans.

High quality, cost effective equipment racks and storage units assemble easily and all are constructed durably. They mount and remove easily and are convenient for any application. Each has an attractive finish to enhance any facility.

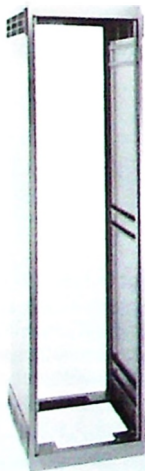

*Slim 20*

**Slim 20 & Slim 50 Steel Racks**

The Slim 20 is a solid sided electronic enclosure designed for durability, aesthetics and easy of use. The Slim 20 features 14 gauge steel top and bottom; 16 gauge steel sides, 21 1/8" wide and 21" inside depth. The Slim 50 is also a welded electronic enclosure designed for maximum flexibility and features 12 gauge steel corners, 14 gauge steel tops and bottoms. The Slim 50 is a very slim 21 1/8" wide and is available with 25" or 30" inside depth and features optional removable side panels. Both the Slim 20 and Slim 50 are knocked down or factory welded; 1/4" internal steel brace; have electrical knockouts and cable entry; locking rear door and are attractive with a black powder coat finish. Options include solid or vented steel front doors, Plexiglass™ front doors and castor bases.

**RK Series Equipment Racks**

The RK Series from Middle Atlantic are high-quality inexpensive equipment racks for use in the studio. Constructed of 3/8" thick high-density particle board with an attractive black laminate. Full hole 10-32 threaded rack rail is preinstalled. Rack ships flat, easily assembled with included allen key. Optional rear rack rail and castors. Two depths available.

Part #	Height	Depth
RK-2	3 1/2"	16"
RK-4	7"	16"
RK-8	14"	16"
RK-12	21"	16"
RK-16	28"	16"
RK-20	35"	16"
BRK-8	14"	18"
BRK-12	21"	18"
BRK-16	28"	18"
BRK-20	35"	18"



*RK Series*





Single Desk with Monitor Bridge



Workstation with Monitor Bridge



Roll-Around

### Furniture & Equipment Housings

The people at Nigel B have arranged it so that you can mount all of Harris Allied's audio equipment and all of your video equipment in attractive, practical and efficient housings that are specifically engineered for that purpose.

The single desk, pictured above, with monitor bridge and the workstation with monitor bridge are only two of the many variations to choose from. Even the scientifically-designed operator chair shown is available in the Nigel B line.

Nigel B's roll-arounds provide great look, terrific convenience, robust construction and highly attractive pricing. Call us for size, RUs and other features and benefits on these and other exciting new products, as well as the easel for rackmount tape recorders.



Desktop rack-mount AL-DRS



Roll-Around Recorder Stand RS

### FX RACK



#### FX RACK

FX RACK provides the professional studio with 18 spaces of well-designed rackmount "furniture." FX RACK fills the need for an economical 19" equipment rack that can be used for "outboard" signal processors, patchbays, tape decks, power amps, etc. The all-wood design eliminates ground loop problems normally encountered when "unbalanced semi-pro" equipment is rack mounted. FX RACK is very compact, requiring just over 2 sq. ft. of space. It is shipped flat and requires only a screwdriver for easy assembly. Solid maple rack rails. Dimensions: 39½"H x 20"W x 15"D.

FX RACK with casters

### HARRIS ALLIED

#### Equipment Cabinet

The beautiful, rugged equipment housing racks stand alone or can be ganged together indefinitely. End panels are universal (L or R) and are sold separately so that you may order only the panels you need, depending on stand alone or ganged installation. The cabinet is constructed of rugged 14 gauge C.R.S., equipment mounting rails are 12 gauge drilled and 10-32 tapped. Side panels are constructed of 18 gauge C.R.S. Thirty-seven rack units of mounting space are provided. Ventilation is provided by louvers in the cabinet top and in rear door. Prepunched holes for wiring access.



- Exterior dimensions: 72"Hx23.5"Wx27"D.
- Equipment mounting space: 64.75"Hx19"Wx24"D.
- Color: Black only.
- Removable side panels.
- Lockable rear door with allen wrench.
- Punched holes for conduit and wiring.

**Acoustical Foam**

SONEX acoustical foam wages a two-front war on noise. First, the patented SONEX wedge traps, deflects, and scatters noise. The wedge's depth and angle carry noise waves down to the lowest point of each anechoic foam valley. Most of it doesn't have the energy to come back up. Then the foam itself converts sound energy to silent kinetic energy. Sound literally gets lost within open cell pores of this special foam. What the wedge doesn't dissipate, the acoustic foam controls — to give you ideal acoustical performance. Together this two-pronged attack delivers the best sound control you can get. Call, fax or write today for all the facts and prices on SONEX.



**Ceilings**

We now offer the complete line of SONEX ceilings. These 2'x2' suspended ceiling tiles combine dramatic style with state-of-the-art acoustical performance. The tiles are constructed from light but durable melamine foam and they carry a Class 1 building material rating. If you want to improve the look, and acoustics, of your facility, SONEX ceilings may be the answer. Call today for all the information.

SHEETS (4'x4')	Depth	Sheets Per box	Sq. Ft. Per box
Charcoal, Brown, Tan	2"	8	128
	3"	6	96
Painted Colors Silver, Blue, Brown, Orange	2"	8	128
	3"	6	96
	4"	4	64
AUDIO TILES (15"x15") Natural colors Charcoal, Brown, Tan, Blue	2"	28	50
Painted Colors Silver	2"	28	50
	Box of Tiles include 3 tubes of adhesive.		

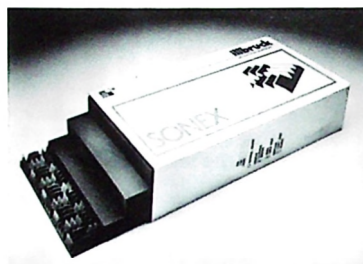

**"UPS-able" SONEX**

Now the same great SONEX acoustical foam is available in 2'x4' sheets which can be shipped by UPS. Same unbeatable performance of full-size SONEX sheets but easier to ship and easier to handle. Most sizes and colors can ship in a matter of days — call for all the details.

Thickness	Order number	Sheets per box	Square feet
2	UNX-2	8	64
3	UNX-3	6	48
COLORS Charcoal, beige, brown			

**MIXRAK**

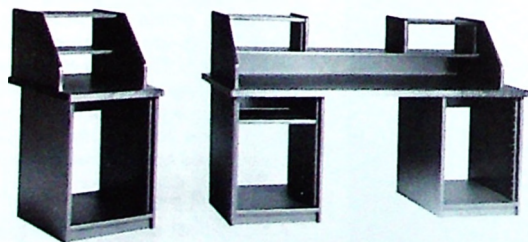

**Studio Rack Furniture**

MIXRAK™ introduces a new line of professional studio rack furniture which provides you with an array of possibilities and allows you to construct the system that best suits your needs. The modular design makes it easy to assemble and add to your system as needed. Board surfaces are protected by melaface and high-pressure laminate. The desk is edged with 1½" solid oak and the remainder of the edges are protected by a durable T-Molding. Heavy threaded rack rail ensures safe and proper alignment. All MIXRAK products assemble quick and easy. Call today for exact descriptions.

**PFT**

**Equipment Racks**

PFT Modular Enclosures are designed to provide strength and rigidity. These heavy-duty steel cabinets offer an extraordinary value compared to traditional, fully welded units. PFT Modular Enclosures are as strong as welded due to heavy gauge steel frame coupled with the unique interlocking corner joint structure. All PFT cabinets are available knocked down, for exceptional freight savings, or fully assembled. PFT also has a complete line of accessories available. All PFT cabinet parts, including frame components, are removable, interchangeable and replaceable. PFT will make in-plant modifications to your specifications. Available in 8 standard color combinations.



**UPS Systems**

Provide power line protection for everything from a single PC to your entire operation with an advanced Uninterruptible Power System from Best. The FERRUPS® come in sizes from 500 VA to 18 KVA and have Active Voltage Regulation technology. With AVR, the FE series FERRUPS® converts even the poorest quality AC into computer-grade power. It converts a wide range of line voltages to perfect output power without depleting the batteries. But when the unexpected outage strikes, it switches instantly.

Many of the Best UPS systems can also be installed in the optional 19" rack kits. If you need AC power for long runtimes for motor-driven loads, pumps or transmitters, take a look at the Best Hi-Surge™ Power Inverter. Combined with a Best UBS® (Uninterruptible Battery System), the inverter gives hours, days or weeks on non-stop AC power. To help you make your UPS selection, call and ask for our free full-color Best catalog on a disk that will run on most PCs.



**CONTROL CONCEPTS**

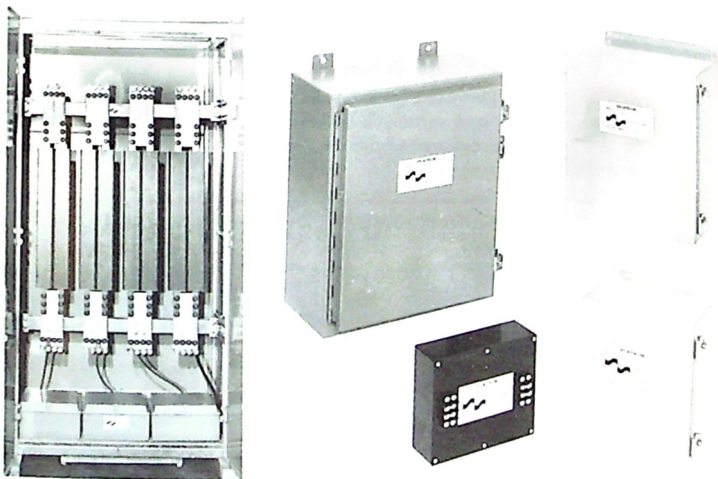

**ISLATRON®  
Power Protection Equipment**

From 5 amps to 1200 amps, Islatron from Control Concepts supplies protection for all kinds of broadcast equipment. Islatron effectively stops lightning induced voltages, spikes and transients in their tracks. Protected by four U.S. patents, no other device works or protects like Islatron.

Almost all modern electronic equipment is designed with some level of built-in power conditioning, but that may not be enough protection. The ISLATRON® Isolation Transformer with Active Tracking Filter protects against the full spectrum of AC power pollution — high energy and low energy transients in both common mode and normal mode. For voltages, frequencies or applications not mentioned, please call your Harris Allied representative today.

**EFI**

**MXPB  
AC Line Protection**

The modular designed MXPB branch-panel transient voltage surge suppression (TVSS) system is for the most demanding environments. High energy protection, redundant surge suppressor, noise filtration and common mode protection for Wye and Delta Systems make it the most powerful TVSS system. Also features Sine Wave Tracking™, integrated diagnostic circuit and is UL listed with a 5-year warranty.

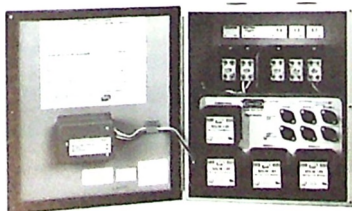

**MA5  
Panel-mount TVSS  
System**

The MA5 branch-panel transient voltage surge suppression system (TVSS) offers a modular design for easy maintenance with one module dedicated to each phase for applications requiring high-voltage capability and/or multiple phase power protection. Five modules ranging from 120 to 480 Volts, adapt to nearly every multiple-phase transformer configuration possible. Capable of remote monitoring.

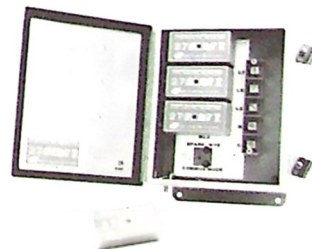

**ETA**



**ETA Power Distribution**

ETA Power Distribution and conditioning units are a better way to handle the AC power needs of your rack mounted equipment. The built-in EMI/RFI filtering helps protect against damaging sudden voltage spikes and surges plus reduces unwanted interference. All models include at least 10 U-grounded 120 VAC outlets on the rear panel with 8 controlled by the front panel switch and 2 always on. Also on the front panel is an LED power on indicator and unit reset breaker. Other models include digital voltmeters, swivel retractable rack illuminators with hi/lo intensity switch or sequential on/off operation of outlets.

**RADIO SYSTEMS**



**DTCT-6**  
Tabletop **clock/timer** with 2 separate 6-digit displays.



**DWT-6**  
Wall or rack mount, 2" display, 6-digit **timer**.



**AMD-1 Analog Master Clock Driver**

The AMD-1 drives up to 50 analog clocks. May be synchronized with digital displays and can accept external time base. Full function rear panel remote.



**TM-3**  
Stand-alone **timer** counts to 99:59:59. Full remote control.



**DWC-6**  
Wall or rack mount, 2" display, 6-digit **clock**.

**AC-12 Analog Clock**

The AC-12 is a 12" analog wall mount clock with large black numbers and red second-hand that sweeps over a calibrated 0-60 scale.

**AUDIO-METRICS**



**ST-3 Studio Timer**

The ST-3 Studio Timer by Audio-Metrics is designed to count up to a maximum of 23 hours, 59 minutes and 59 seconds, plus has a crystal time base and big, bright  $\frac{3}{4}$ " displays. Front panel, soft-feel buttons permit start, stop and reset and their functions are duplicated on rear panel wire capture screw terminals for remote access. The beige color is compatible with your decor and the weighted base and rubber feet prevent unwanted movement of the unit.

**ESE**



ES-172A



ES-112E

**Digital Clocks/Timers**

The ES-172A is a console mount clock/timer in a compact enclosure, with bright, easy to read, six digit .4" red LEDs. Unit has access to control inputs on rear mounted connector. Enclosed in high-impact black plastic case. (ES-172A - 2.16"Hx4.5"Wx4.13"D). The ES-112E is a solid-state 12-hour CMOS, six digit clock that can be set to the precise second. Bright orange display, gas-discharged, .55" high digital. (ES-112E - 2 1/2"Hx8"Wx6"D).

**HARRIS ALLIED**



**Standard Quartz Clock**

The standard in studios and control rooms around the world is the Harris Allied Broadcast Quartz line of clocks. Where accuracy and visibility are a must, the Harris Allied line is just what the announcer or engineer ordered. 12" face size. A similar clock is available from ESE which may be impulse driven.

**CRL**



**Real Time Event Sequencer**

The CRL Real Time Event Sequencer is a one rack high unit, programmable event timer that can control any combination of eight or one of 255 outputs (binary encoded) via a rear panel barrier connector. A circular menu approach, and seven day clock program makes the unit easy to operate. Security keylock and battery backup included.

## AUDIO-METRICS



**Model 51900**  
Hold everything mic arm  
(Black or beige)  
1 ft. riser included



**Model 14198R**  
Single mic arm  
Lightweight version  
of 51900  
(Black or beige)  
1 ft. riser included



**Model 51900-3**  
Triple mic arm  
Beige Only  
1 ft. riser  
included



**Model 12042**  
Heavy springs (Pr.)



**Model 14100**  
1 ft. riser  
(Black or beige)



**Model EB-1**  
Extension arm  
(Black or beige)



**Model 11426**  
Wall mount  
(Black or beige)



**Model 11427**  
Bench mount  
(Black or beige)



**Model 14005**  
Clamp mount  
(Black or beige)

**Harris Allied can handle all your microphone mounting needs.**

**Furniture & Studio Accessories**

## ATLAS/SOUNDOLIER

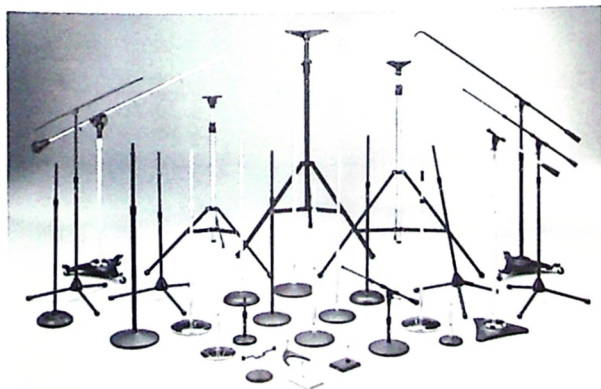

### Mic Accessories

A wide variety of mic stands, goosenecks and booms are available from Atlas Sound® brand and Harris Allied for every application. Whether it's for the studio, portable or mobile application, there's an Atlas Sound stand for the job and Harris Allied can supply it.

## LUXO

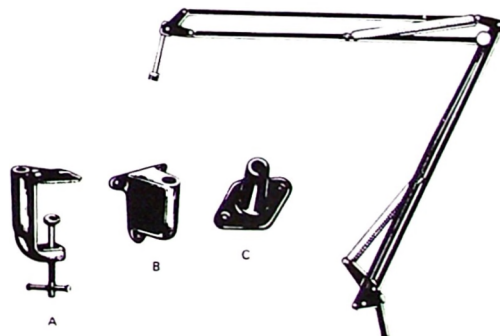

### LM-1 Mic Arm and Base

The LM-1 from Luxo is a high-quality piece of studio furniture. You have a choice of three mounting bases. Please specify base A, B or C. Color selection: oyster or black.

*Certain products not available in some areas.*



## AUDIOLAB

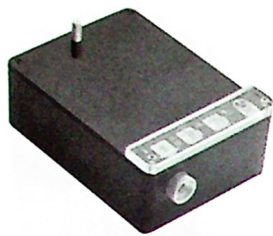

### TD-1B Tape Degausser

The Audiolab tape degaussers with automatic overheat thermal protection erase audio tape, carts and cassettes. They erase up to 2" tape widths, accommodate up to 16" reels, provide a wide focused magnetic field to assure complete erasure and positive results every time with a simple operation. Dimensions: 3"H x 5¼"W x 7¼"D, shipping weight: 9½ lbs.



### TD-4A Tape Degausser

The Audiolab TD-4A tape degausser completely erases ½" VHS, S-VHS, ¾" U-Matic, 1" C/B Format, DAT and Cr02/Metal tape. It has continuous duty operation, automatic cooling fan operation, overheat light with automatic thermal protection. Very popular, easy to use, and providing great results in the audio, video and computer industries.



### TD-5 Tape Degausser

The Audiolab TD-5 metal tape degausser is a high-quality, inexpensive metal tape eraser that assures a complete erasure of those hard to erase tape formats such as MII, D2, Betacam SP and other tape formats up to 2" in width and 16" in diameter. Has continuous duty operation for low to medium coercivity tapes. Has automatic cooling fan, overheat light and thermal protection. The TD-5 is the only degausser you'll need to erase all of your tape formats.

## GARNER

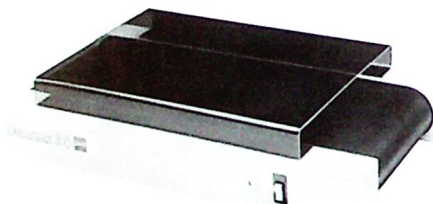

### 105 Dataraser

The Garner 105 Dataraser takes just 4 seconds to erase all sizes and types of audio tape. Garner has designed their units to automate your tape erasing operations and eliminate residual noise problems. Discover the advantages of degaussing computer media with the Dataraser 105, which accommodates up to 10½" reel, floppy discs and other magnetic media.

## HARRIS ALLIED

### Cleaning Sticks

Cotton tipped swabs for lubricating and cleaning recorder heads and other hard to reach areas. Supplied in 10-100 qty. bags per package.



### Razor Blades

Harris Allied supplies your broadcasting facility with single edge industrial razor blades to fit all standard razor blade tools. 100 per package.



## R & K



### 17 Tool Kit with Case

USA-manufactured tools include names like Weller®, Channellock®, Magna® and Xcelite®. Assembled and neatly packaged in a 17PE case. R&K backs their assembled tool kits with a lifetime guarantee on all of the hand tools in their kits. If a tool breaks, simply return to R&K for a replacement at no charge.

## TECHNICS



### SL-1200MK2 Turntable

The Technics SL-1200MK2 has many improvements. In addition to being quartz-locked direct drive, it permits continuous speed adjustment under quartz control (within a range of  $\pm 8\%$ ). Its starting torque is a high 1.5 kg/cm, with the platter reaching rated speed within 0.7 second from standstill. The SL-1200MK2 should also be virtually feedback-proof because of its special base design. The SL-1200MK2 includes base, tonearm and dustcover. 33 & 45 rpm.

## SHURE

### SC35C Professional Cartridge

The SC35C is designed for use on the heaviest and most rugged tonearms which require a tracking force of 4 to 5 grams. The stylus assembly of the SC35C is rigid enough to withstand the punishment of continuous backcueing, yet compliant enough to offer excellent mid and high frequency reproduction. The SS35C is the spherical replacement stylus for this cartridge.

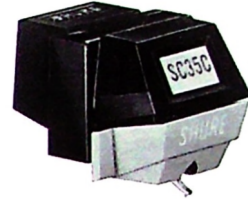

## STANTON



### 500AL Professional Cartridge

The 500AL professional cartridge from Stanton is known as the workhorse of the broadcast industry. It meets the extremely rugged requirements of live application without sacrificing performance quality. The 500AL features a fluorescent coated stylus assembly to help cue records to the exact cut, even in semi-darkness.



### 680EL Professional Cartridge

The 680EL professional cartridge from Stanton is the industry standard. It is designed to deliver sound excellence and at the same time stand up to back cueing, vibrations and mishandling. Comes with extra stylus as well as a fluorescent coated stylus assembly to help cue records to the exact cut even in semi-darkness.

## ANVIL CASES

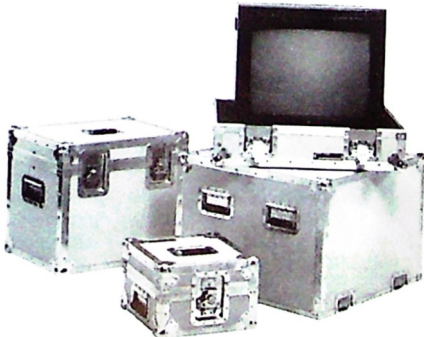

### Shipping Cases

Anvil builds a strong case around any computer, broadcast, video, or audio visual system as well as any combination of equipment requiring protection for travel storage. Each case is designed to exact specifications for a quality fit. Interiors are custom designed for maximum shock absorption and vibration resistance. Fully compliant with the Air Transport Association.

## STARCASE



### Shipping Cases

Protect your investment in quality equipment by packing them safely in standard stock or custom cases before your next remote. Reinforced corners, recessed handles and latches and strong side panels help to ensure protection of delicate equipment. Call us with equipment type and/or dimensions for a competitive quote.

**ENBERG**

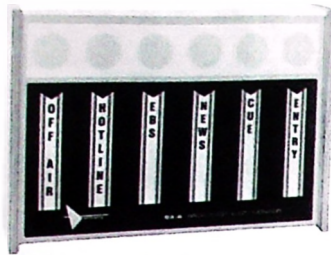

BA-6

**BA-6**  
**BA-6R Remote**  
**BA-6RX (Rack Mount)**  
**BA-6RXR Slave (Rack Mount)**  
**FN-6 (included w/BA-6, BA-6RX)**



BA-6RX

**BA-6 & BA-6RX Alert Monitors**

Enberg alert monitors can provide your control room with a practical, versatile and attractive system for keeping informed of important status conditions. Three modes of operation on each channel: telephone-latching, auto reset and manual reset. Other features include opto isolated inputs, solid state relays and flashing 4000HR indicators. A DC output for each channel is provided capable of driving remote monitors and piezo buzzers, etc. Thirty standard labels included, custom labels are available.

**HARRIS ALLIED**



Micro Series



Standard

**Micro Series Warning Lights**

The Harris Allied Micro Series warning light has one 1820/28 volt lamp, designed for use with 24 volts for extended life. All models mount on standard single gang wall boxes or plaster rings. The wedge shaped translucent cover is available in red or white. L-101, 24 VDC, available with ON AIR or Blank. The Harris Allied Standard Model warning light is a durable, highly visible and efficient on-air warning light, 7<sup>7</sup>/<sub>8</sub>"Hx5<sup>1</sup>/<sub>4</sub>"Wx4<sup>3</sup>/<sub>8</sub>"D. Available horizontal or vertical with or without flasher. Model: Ken Lamp, Ken Flasher

**FIDELIPAC**



**Model 340 Warning Lights**

Your broadcast or recording studio will really be "off limits" when Fidelipac studio warning lights are lit. Their brilliant red lettering on jet black background can be seen even in the brightest ambient light conditions. With a faceplate of unbreakable Plexiglas, the light includes lamps and mounting hardware. RECORDING message also available. Custom legend minimum 6 pieces. Size: 5"H x 10"W x 2<sup>1</sup>/<sub>2</sub>"D. 110 VAC easily adaptable to 220 VAC. Also available with ON AIR in French, German, Greek, Polish, Russian, Spanish or Swedish Model 340-S.

**TITUS**



OAL-HS



OAL-VS

**ON-AIR Lights**

Finally an ON AIR light that adds to the appearance of your studios! Titus Technological laboratories' ON AIR light provides the broadcaster and recording studio with a beautiful but practical means of indicating a studio is in use. They feature a smoked plexiglass window mounted in either a gold or silver frame which is mounted in a solid oak base for wall mounting. The light uses four 24 VDC bulbs which almost completely eliminates the chance of total failure. Bulb replacement is quick and easy. The ON AIR or RECORDING only appears when illuminated and is blacked out when not in use. OAL-(xyz)

**Please Specify:**

- x - H = Horizontal, V = Vertical lettering
- y - S = Silver, G = Gold frame
- z - blank = "ON AIR," R = "RECORDING"

**Need it Now?**

**We'll FedX your order today!**

**One call to Harris Allied will solve all your broadcast needs.**



*Specifications subject to change or revision.*



## ADC

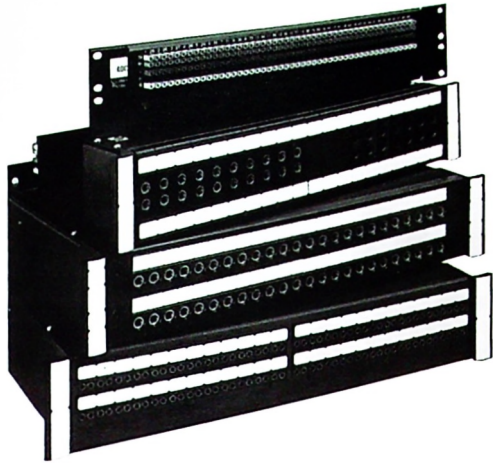

### Patch Panels

ADC's Pro-Patch jackfield is truly state-of-the-art, incorporating the split cylinder contacts. Pro-Patch units are reusable and especially suited for remotes, special broadcasts and advance builds, with the ability to change circuits and normalling configurations in seconds.

Ultra-Patch panels, another innovative product utilizing ADC's split cylinder technology, were designed to provide yet another set of options for audio patching and interconnect requirements. Ultra-Patch panels can be terminated at the factory to any of ADC's standard or custom jackfields and may be rack or wall mounted.

ADC's standard line of audio jackfields feature an extensive selection. Choice of jacks, panel size, normal line options, cable length (3 to 8 feet) and variety of terminations (stub end with leads identified or ADC's ultra patch panel) combine to give you more than 280 possible configurations.

All ADC products are available pre-wired or unwired.

## CANARE



### Impedance Transformers

Canare Impedance Transformers are designed to convert 2-channel digital audio signals between balanced 100Ω XLR and unbalanced 75Ω BNC. This cost effective adapter allows you to switch from a limited length microphone cable to a much longer IMPEDANCE MATCHED 75Ω coax cable. Now, conveniently route D1, D2, R-DAT and DAW signals via 75Ω Canare Video Patchbays, BNC plugs and super flexible Coaxial Cable. Advanced system solutions for your future available through Harris Allied.

### Canare Cable Reel Snake

A unique and economical approach to multi-channel cable storage. Assembled with a durable R-Series Canare Cable Reel, built-in flange mounted junction box, hardwired Star Quad L-4E3-P multi-channel audio cable and multi-pin female connector.

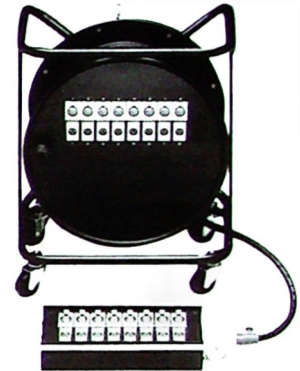

### Canare Cable and Wire

Harris Allied also can supply the popular Star Quad L-4E3-P multi-channel audio cable, 75 ohm coaxial cable and connectors, cable assemblies plus the newest 110 ohm digital audio cable.

## HARRIS DRACON

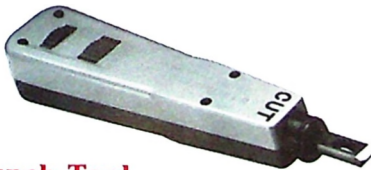

### D814 Punch Tool

For punch board wiring applications, these tools are the most efficient method utilized. S66MT — spring loaded; S66BT — manual; D814 — automatic.

## SWITCHCRAFT

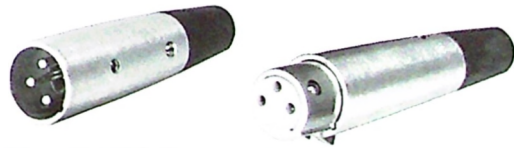

### A3M and A3F Connectors

Harris Allied supplies Switchcraft connectors for audio, broadcast studio instruments, consoles, microphones and other broadcast industry applications.

## SIEMON

### 66 Punch Blocks

The "66" punch blocks are the easiest way to accomplish complex wiring projects. A must for efficient console, rack mounted equipment or other types of wiring installations. S66B3-75 — group of 2 clips x 3; S66B3-50 — group of 3 clips x 2; S66B4-25 — group of 6 clips x 1.

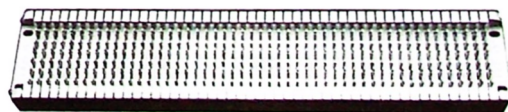

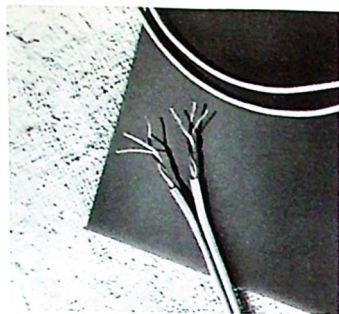

**1504 Stereo Audio Cable**

The Belden Stereo Audio Cable is dual shielded pair 22 AWG (19x32) tinned copper, 19 strand flexible chrome, PVC insulated and jacketed in zipcord type construction with one pair stripped for identification. NEC CL2 rating allows wall installation without conduit.

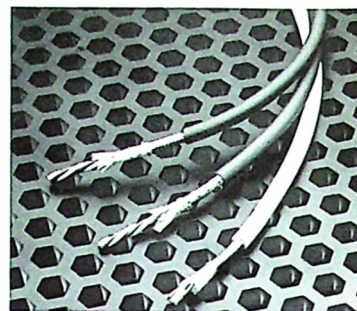

**1192A Mic Cable**

The Belden 1192A Brilliance<sup>®</sup> mic cable provides superior noise immunity and consists of four 24 AWG P.E. insulated conductors cabled with an overall 95 percent tinned copper braid and highly flexible matte finish PVC jacket. Extremely easy to work with in all microphone applications.

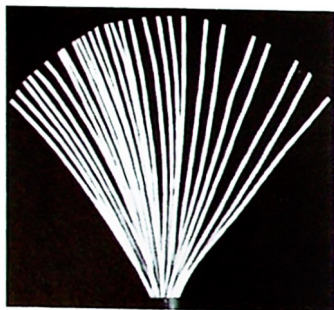

**1200 Series Snake Cable**

Belden's 1200 Series of multi-conductor snake cable features individually shielded and jacketed pairs. These cables interconnect audio components such as console board equipment for the broadcast industry. The loose tube construction allows for high flexibility, while the PVC outer jacket features an over-all non-reflecting black matte finish for a low profile appearance. The PVC inner jackets are numbered for ease of identification.

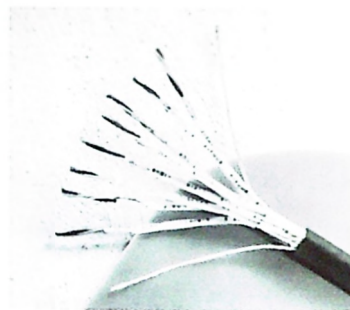

**1508A Audio Snake Cable**

The Belden Multi-pair Audio Snake cables with 24 AWG (7x32) tinned copper, polyethylene insulation, individually shielded and jacketed pairs provide optimum crosstalk isolation. The pairs are alpha numeric bi-directionally numbered for ID. Overall Beldofield shield with 18 AWG (7x26) tinned copper drain, PVC jacket with nylon ripcord gives a low profile, good durability and flexibility.

*We still carry Belden 8451 the industry standard cable.*



**The entire West Penn line is supplied through Harris Allied.**

**Cable**

Put some color into your life by using West Penn easy to strip shielded cable. A particular favorite of broadcasters is #291 two conductor twisted pair shielded cable. Number 291 comes in

22 AWG stranded with a 24 AWG drain wire with insulation color of white, red, brown, black, yellow, green, gray, blue, violet or orange. This product is comparable to the leading manufacturer: but at reduced prices. The multi-pair 400 series and the CL2 series is also offered through Harris Allied.

Also consider the versatility of the 430 series of multipair cable. If it's coaxial you are after, ask for 843 or Q843 and as technology changes to fiber optic we have a proven cable for your application requirement. Whatever your broadcast or specialty cable need is you can solve it with quality West Penn Wire economically that meets UL and NEC guidelines.

# Belden has **BIG NEWS** for the broadcast industry



**Belden is on the air with the industry's largest portfolio of new broadcast cables.**

More than 60% of the products listed in Belden's new Broadcast Catalog didn't even exist just 2 years ago! Belden's new 48-page Broadcast Cable and Connector Catalog provides specifications for the industry's most complete line of cabling products, including audio multi-conductor cables, microphone cables, video coaxial cables, video triaxial cables, audio & video composite cables, bundled coaxial composite cables, fiber optic cables, cable assemblies and connectors.

#### **New levels of excellence and innovation**

During the past few years, Belden has introduced more product innovations for more broadcast cabling applications than any other cable company. This commitment to innovation and technical excellence is the reason Belden remains the broadcast industry's No. 1 cabling choice, worldwide. It's a position we've worked hard to earn and will fight hard to keep with new products, new options and even higher levels of excellence in the future.



**Belden**

## GEPCO

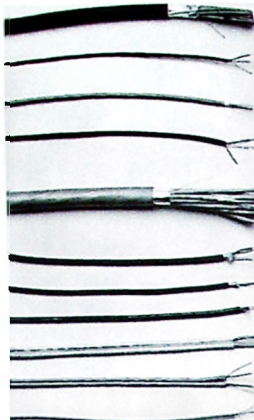

### Audio Cables

Gepeco manufactures 5 types of multi-pair cables, GA618 series (22 AWG), GA724 series (24 AWG), GA724M series (24 AWG), GA803 series (26 AWG) and the FP series (26 AWG oxygen-free copper, super flex). Single pair products include 61801 (22 AWG), 61801 EZ (bonded foil), D 61801 EZ (dual channel) and 72401 EZ (24 AWG). Gepeco's new 110 ohm digital audio cables include 5524 (single pair), 552404, 552412 (4 and 12 pair), 5526 patch cable and 5524 SD (solid conductor). Microphone cables, in 2, 3 and 4 conductor constructions, are available for any use.

Speaker cables include twisted pair with jacket in 12, 14, 16 and 18 gauge constructions and parallel zip versions with 10 or 12 gauge oxygen-free copper conductors.



### Video Cables

Gepeco manufacturers a complete line of coax and triax products for video applications. Coax products include standard RG59 type cables such as V618J59, VJ59U, V618M59 and VE61859. The precision video cables are: VP6000, VP618PE01 and VP618PVC. Miniature precision cables include VPM2000, VPM2000TK, VFM809 and VDFM809. Gepeco also has RGB, RGBS and RGBSC in miniature precision. Gepeco is also a primary source for triax cable RG59 triax includes VT61859 (CL2) and LVT61859. RG11 products are VT61811 (CL2).

LVT 61811, VT61811PE and VT61811PE/AP. Call Harris Allied to supply Gepeco cable for all your video applications.

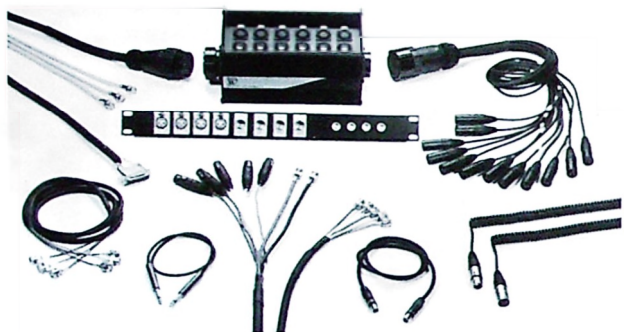

### Audio & Video Custom Products

Gepeco, dedicated to manufacturing custom products for the broadcast industry, will assemble your custom needs for all audio and video applications. Gepeco's large selection of breakout boxes are custom made for stage and field applications. Gepeco also offers special application audio and data cables in multi-pair or multiconductor, shielded and unshielded constructions. Gepeco products are designed, developed and proven for the broadcast industry and conform to UL and NEC requirements.

## HARRIS ALLIED



### 66 SwitchPad

The 66 SwitchPad features compact plug-in switch selectable attenuators that install directly onto split 66 type connecting blocks to provide flexibility in establishing circuit loss levels on dry voice or data circuits. Space saving 66 SwitchPads provide 0 to 31 dB attenuation in 1 dB steps.

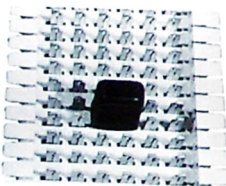

### O Pads

Where specific attenuation is needed the Harris Allied "O" pad can provide a choice of 3, 6, 10, 17 or 23 dB attenuation.

### ST Connector

Easy punch block hook-up is available with the standard of the industry, the 3M "ST" connector.

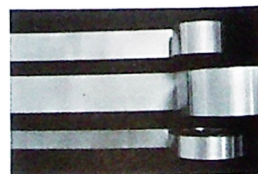

### Copper Products

Harris Allied, the broadcast industry's major supplier of copper, offers #8 and #10 ground radials, .020 or .0322", 3", 4", 6" and 8" strap, flyscreen and groundscreen. Call us today for complete information.

Harris Allied can offer everything you need to establish a type "66" punch block wiring system in your studio or station.

# Audio, Video & Broadcast Cables

*Cable products designed, developed, and proven for professional use.*

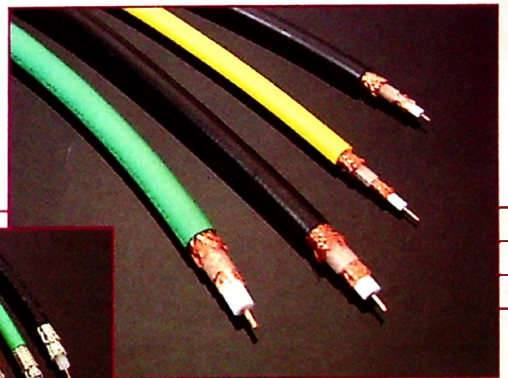
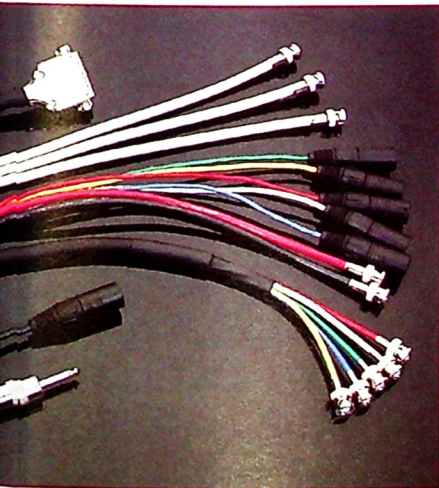
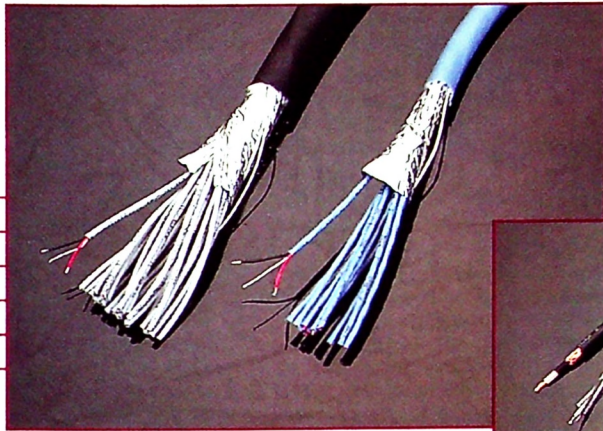

**GEPCO INTERNATIONAL**

# GENTNER

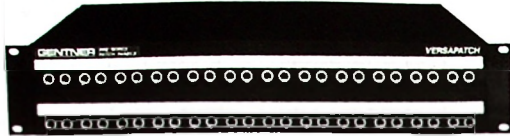

Front View

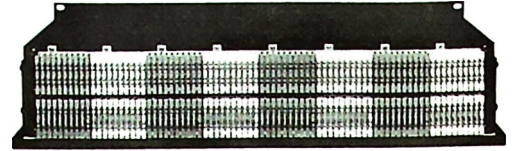

Rear View

## Versapatch II

Simplify your wiring projects with Gentner's Versapatch II, a chassis-enclosed audio patch panel. Versapatch gives you 48 jacks, configured in dual rows of 24, with offset jack spacing to accommodate stereo patching. Rear panel connections are made on Flexiblocks - punch blocks designed especially for stranded wire. (Special

tool required; order Gentner's Flexitool, or a Flexitool blade for your D714 punch tool.) Versapatch units are two rack units high and 13.25" deep. Three types of normals wiring are available: AB (normals strapped top to bottom); TRB (Top Row Bridging, bottom row breaking), and BO (normals brought out to the rear panel termination).

**Video Patch Panels are now available from Gentner.  
Call Harris Allied for details today!**

## Pre-Wired Patch Panels

Gentner pre-wired patch panels give you 27 kinds of flexibility in your wiring project, with your choice of three types of bayfronts (48, 52 and 96 jack models, all dual row), three types of normals wiring (AB = At Bay, TRB = Top Row Bridging or BO = Brought Out) and three types of terminations (PU = Punch block; FB = Flexiblock, or SP = SuperPatch). To order, combine your choice in each area. For example, a 48 jack patch panel with normals wired at bay and SuperPatch terminations would be ordered as a 48DR-AB-SP.

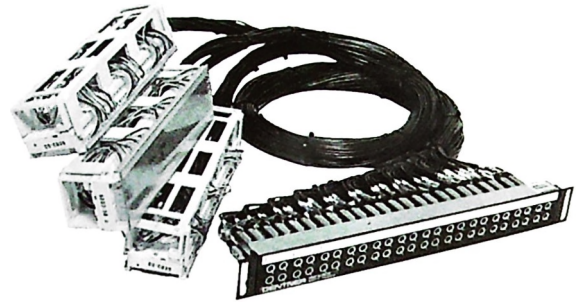

All standard models of Gentner pre-wired patch panels have a cable length of 5 feet, with cable bundles dressed to the left as viewed from the rear. Custom patch panels are also available.

Patchbay configurations available:

- 48 jack 2 1/4" rack height (two rows of 24)
- 52 jack 1 3/4" rack height (two rows of 26)
- 24 jack 1 3/4" rack height (single row)
- 96 jack 1 3/4" rack height (2 rows of 48 bantam)

Though many models are available, the following double row (DR) models are most common:

Jack Type	Normals	Termination	Jacks	Part Number
T-R-Slv	At Bay (AB)	PU	48	48-DR-TRS-AB-PU
T-R-Slv	At PU	PU	48	48-DR-TRS-BO-PU

Terminations:

PU: Punch block termination. Punch blocks - Siemons #66B375.  
\* of terminals - 3 x 75

FB: Wired to the Gentner Flexiblock punch block.  
\* of terminals - 1 x 50

ET/FB: Easy Term/FB. Equivalent to 3.2 Flexiblocks on a 3 1/2" hinged rack panel.

SP: SuperPatch. One or two rows of Flexiblocks on a fixed 3 1/2" or 5 1/4" non-hinged rack panel.

**Harris Allied carries the entire Gentner line.**



## Flexiblock

The Gentner Flexiblock is an insulation-displacement punch block system made specifically for stranded wire. Connections to Flexiblock are fast, easy and reliable. A high number of connections may be made in a small space (up to eight connections per circuit) and connections are virtually short-circuit proof.

### FB100

**Miniblock FB10, 1x20 terminals, 2 slots per terminal (2"L x .93"H x 1.75"W)**

## SuperPatch

The Gentner SuperPatch termination system defines the superior method for mounting Flexiblocks in a rack. The SuperPatch is non-hinged to provide more space to route wiring. Two configurations available:



### SuperPatch/1 (SP/1):

The SuperPatch/1 uses 1 row of Flexiblocks on a 3 1/2" panel, providing 160 terminals with 2 slots per terminal (equivalent to 1.6 Flexiblocks).

### SuperPatch/2 (SP/2):

The SuperPatch/2 uses 2 rows of Flexiblocks on a 5 1/4" panel, providing 320 terminals with 2 slots per terminal (equivalent to 3.2 Flexiblocks).

## AKG



K141-2



K240M



K18



K270HC

### K141-2 Monitor Headphone

The K141-2, an ultraspacious, dynamic supra-aural professional monitoring headphone is capable of high sound pressure levels while maintaining low distortion and wide bandwidth. Features AKG's patented self-adjusting headband. Matches 4-600 ohm outputs.

### K240M Monitor Headphone

The K240M monitor headphone is an established professional standard in the studio. This deluxe circumaural stereo headphone provides better directional sound perspective and distance discrimination, faithfully simulating hearing in natural room conditions. Matches 4-600 ohm outputs. Also available in a calibrated variation, the K240DF studio monitor, which is designed with a flat frequency response based on European requirements for a reference monitor headphone.

### K-18 Earphones & Mic

The K-18 is an ultra-lightweight boom set. It consists of two monophonically connected dynamic earphones and boom arm with noise-cancelling dynamic microphone. The headphone matches with 4 to 300 ohm outputs and comes with a 3/4 ft. cable with stripped and tinned leads.

### K270HC Headset with Microphone

The new AKG K270HC headset with microphone is as professional as they get. Headphones feature a frequency response of 20 to 20,000 Hz and a system impedance of 75 ohms. Headphones are closed for maximum noise attenuation. The K270HC incorporates the C410 boom condenser hypercardioid mic which shuts off when you swing it up over the headphones. Automatic muting of the headphones when you remove the headset prevents leakage into the microphone.

## ASTROLITE



2636-G1



2637-G1

### 2636-G1 Headset with Microphone

The 2636-G1 has ear-enveloping cushions which provide attenuation for use in noisy environments. The close-talking dynamic mic equals the performance of studio microphones — even in high ambient noise levels. Comes with standard earphone cushions. Ventilated cushions and cough switch are optional. Connectors not included.

### 2637-G1 Headset with Electret Mic

The Astrolite 2637-G1 is the perfect sportscaster headset for environments with crowd noise or other background interference. Its noise cancelling electret microphone is mounted on a double sided headphone and comes with polarization circuitry. The coil cable has a "Y" junction for separate connectors. Connectors not included.

## KOSS



PRO 4AA



HV PRO

### Pro 4AA Headphone

The Koss Pro 4AA, back again by popular demand! Studio and broadcast professionals have long preferred the full frequency, deep bass sound of Koss' professional headphones. Foam-filled pneumatic ear-cushions provide a tight seal that totally isolates the listener from distracting outside sounds and irritating feedback. One inch voice coil. Extended range for precision monitoring. Lifetime warranty.

### HV PRO Stereophone Headset

The Koss "no questions asked" lifetime warranty comes with these stereophones which feature high velocity elements for greater detail in mid-range and high frequencies. Variable density ear cushions provide enhanced bass response. There is a volume/balance control on the cord.

BEYER



DT 108K



DT 109K



DT 190

Headsets with Microphones

The DT 108K is a dynamic, single-muff headset with built-in dynamic boom mic (200 ohm). Designed for live remote broadcasting. The headphone is the well known DT 100 which is extremely lightweight and comfortable to wear even over long periods of time. The headphone transducers feature extended frequency response and are virtually impossible to overload. Left and right channels may be independently wired so that one channel can be used for studio talk back and the other for program monitoring, etc. The ear cushions, which effectively attenuate external sounds, can be removed from one or both sides if some background ambience is required. DT 109K same as the DT 108K in a dual-muff configuration.

DT190 Headset/Microphone

The new Beyerdynamic DT190 headset combines the rugged construction and excellent ambient noise isolation of the legendary DT109, with studio monitor quality earphones plus a significantly upgraded, broadcast quality dynamic microphone. The DT190 was developed to respond to requests from sports broadcasters for higher quality monitoring and vocal/speech quality, suitable for on-air broadcasts. The DT190's noise cancelling microphone offers excellent rejection of off-axis sound, such as those typically encountered in sports broadcasting assignments in high crowd noise environments.

CROWN



CM-311 Headworn Mic

The Crown CM-311, a rugged headworn microphone for musicians or sports-casters, sounds like the best handheld microphones — full, clear and distortion-free. The latest in technology, its cardioid pickup pattern rejects sounds from the rear, such as floor monitors

and its noise-cancelling ability rejects sounds at a distance. The CM-311 has outstanding gain-before-feedback and isolation, a pop filter to reduce breath noise plus it does not cover the user's face. Lightweight and comfortable. 9V battery or phantom power. Satin black finish.

FOSTEX

T-20RP Headset

Performance and comfort have made the Fostex T-20RP a standard in the broadcast industry. The RP system assures superior performance, while oversized earpads and a fully adjustable headband assure comfort, even after hours of continuous use. Impedance - 50 ohms, at 1 kHz, sensitivity - 96 dB at 1 mW input, frequency response - 20-30,000 Hz. Weight: 10.5 oz. without cord.



TELEX

V-Series Headsets

The Telex V-Series headsets/headphones are modular. Dynamic and electret microphone cartridges and eleven different cord sets can be purchased separately to create a wide variety of model configurations. The V-220 shown here is a headset with mic cartridge in place on boom.

PH-24 Series Headsets

These lightweight announcer headsets provide hours of comfort with superb audio. The PH-24 has a miniature noise cancelling electret microphone that significantly attenuates background noises. The flexible polyolefin mic boom can be formed with your fingers and swivels so that it can be positioned on either side of the head. It also has an in-line push-to-cough button with on/off battery or external phantom power.



V-220



PH-24

Harris Allied also supplies the complete line of Telex earsets, twin set and mono set components.



Specifications subject to change or revision.



# Standard Tools Of The Industry

Broadcasters, networks and video/film producers the world over demand quality, accuracy and reliability in every product they use.

Employing the most up-to-date technologies, our products have been developed with significant input from professionals like yourself. Years of dependable performance under the most severe operating and production conditions are guaranteed.

Set your standards with beyerdynamic products.



beyerdynamic

## SENNHEISER



HD250-II

**HD250-II Stereo Headphone**

The HD250-II hi-fi stereo headphone from Sennheiser is great for enjoying music in noisy rooms or as monitor headphone. Tonal quality is balanced and clear due to the lightweight aluminum coil. It has an adjustable headband and soft earpads for comfort. Connecting cable of oxygen-free copper is pluggable and with the adapter plug it can be used on all units or hi-fi systems. Two year warranty.

**HD25SP Dynamic Headphone**

Utilizing dynamic drivers in a closed supraural design, the HD25SP from Sennheiser, offers a lightweight, rugged and comfortable alternative in acoustical headphone technology. A professional dynamic headphone, the HD25SP is for listeners who spend a lot of time wearing headphones and need maximum isolation. An adjustable headband ensures optimum fit, while the drivers swivel to accommodate compact storage.

**HMD25-1****Microphone Headset**

The Sennheiser HMD25-1 headset incorporates the high quality speech reproduction of the MD414 mic to complete the perfect pair. The split headband/headphone system effectively attenuates ambient noise. Used in conjunction with the MD414 mic, the microphone/headphone combination creates superior user comfort and audio clarity.

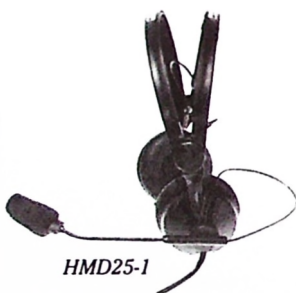

HMD25-1



HD25SP



HD320

**HD320 Open-Aire Dynamic Headphone**

The new *Expression Line* open-*aire* dynamic HD320 headphone from Sennheiser, combines elegant design and long-term listening comfort with superior acoustical technology. It has an ergonomically redesigned headband with micro adjustments for a perfect fit. The HD320 can be connected to all hi-fi components such as CD or minidisc players and DCC or DAT recorders. Two year warranty.

**HD340 Headphone**

The HD340 offers unparalleled design and listening comfort, combined with state-of-the-art transducer technology. Premium triple wound copper coated aluminum voice coils are hand selected and attached. The single-sided cable is also of quality material, made of oxygen-free copper with kevlar fiber for long-term durability. Terminated with 1/8" stereo mini phone plug with 1/4" stereo adaptor. Weight: 4.23 oz. without cable.



HD340

**MKE 48****Microphone/Headset**

The Sennheiser MKE 48 is the professional vocalists choice. The MKE 48 is an ultra-light headset condenser microphone with swivel arm and clearly defined stop. Temple pads give a firm, snug fit with minimal pressure. (Can be upgraded to a full-feature headset by adding headphone elements.) The condenser mic element gives full bass response.

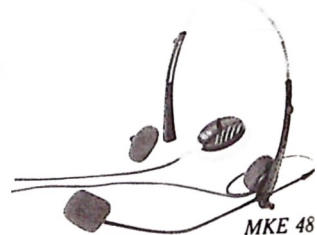

MKE 48

## SHURE

**SM2 Headset**

The SM2 from Shure is a professional headset with a close-talking dynamic cardioid microphone and dual-ear headphones for mono or stereo operation. Microphone element designed for excellent rejection of noise and unwanted sounds. Ideal for TV, radio, film, video and other applications. Large pillow-soft ear pads for external noise isolation; double-braced, covered metal headband for security; cable supplied without connectors. Shure offers a wide selection of head-worn mics with superior sound and comfort. All models include cables and removable foam windscreens.



SM2

## SONY

**7500 Series Headphones**

The Sony 7506, 7504 and 7502 have become a standard in studio applications. The 7506 offers maximum isolation with a large diameter driver. The 7504 offers similar performance with a smaller driver and less isolation. Both the 7504 and 7506 fold into a compact ball for storage or transport. The 7502 is the economical, lightweight version of the series. The low impedance of the 7500 series delivers audible levels in difficult environments.



7506

**Harris Allied has replacement parts for most headphones and headsets.**

## BROADCAST TOOLS



### SMI 5B Intercom System

In a single rack space, the SMI 5B provides a complete intercom system between studios. Connection between studios is accomplished with standard 25 pair phone cable. One optional SMI 25P interface adapter is required to interconnect up to 5 stations. A rear DB-25 connector brings out all front panel switches and tallies.

## COMREX

### CTA/LQPRA Cue System

The Comrex Cue System, CTA/LQPRA, relays both program audio and instructions from a transmitter, installed in a van, studio, press box or stadium, to a pocket-sized receiver. The two audio signals are combined so that cue audio automatically overrides program, but program remains audible. The 1-watt, rack-mount CTA Cue Transmitter operates at 26MHz. The compact LPQRA Receiver provides 6kHz audio response. Receiver is 3"Wx1"Dx5"H complete with leather belt pouch and headphone. Operates on 9V alkaline battery. Audio output: 500 mW into 8 ohms. Features FM, 100% duty cycle, broadcast quality audio, crystal control and is FCC type accepted.



*Comrex Cue Equipment is built for ENG/SNG field control and configured specifically to provide maximum field operating range with broadcast quality audio. Comrex Cue Equipment is rugged, portable, easy to operate and capable of continuous operation.*

## RTS

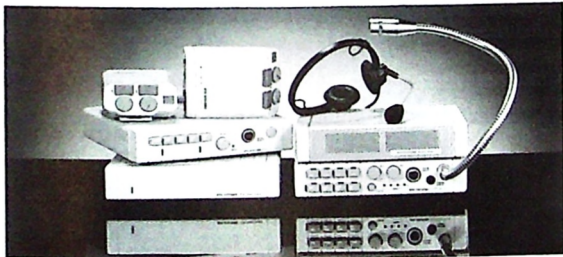

### TW Intercom System

The TW Intercom System operates in a full duplex mode: simultaneous talk and listen, to and from each user station. While a minimum of two user stations and a power supply are required for communications, up to 75 user stations can be employed. The circuitry permits 12-volt power operation, low-cost multi-channel selection, dry line capability, 2-, 3- or 4-wire line formats, a 10 mile operating range and balanced line operation. Series of options available for any requirement.

*Harris Allied supplies the complete RTS line, including wireless intercoms.*

## TELEX

### Audiocom™ Intercom System

The new Audiocom™ intercom system user stations are compact units with up to 18 channels. Expansion station, power supply and speaker components are easy to add with rack mount kits. Both user and expansion stations are one rack high and only one-half rack wide. Powered speaker monitors are one-quarter rack wide. The system's components: US-2000 - 2-channel user station; ES-4000-4-channel expansion station; SPS-2000 - 2-channel power supply and speaker; SPK-1000 - powered speaker monitor.



## APHEX



### Model 124A Audio Level Interface

The Aphex Audio Level Interface is designed to allow use of -10dBV consumer hi-fi equipment with +4 or +8 dBm professional and industrial audio systems. The 124A provides an extremely clean, reliable two-way buffer so both systems can operate at maximum performance levels, matching impedances and operating levels. Features also include digital ready, transformerless outputs, servo balanced inputs and outputs, recessed controls, and push-button 600 ohm input termination.

## ATI

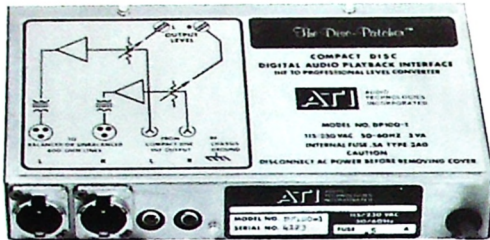

### DP100 Impedance Interface

The DP100 uni-directional stereo interface is designed to invisibly interface digital compact disc playback units with absolutely no reduction of the superb performance available from the digital system. Equally at home on a newsroom desk, use the Disc-Patcher to patch ENG cassette recorders into your system for dubbing. RF proof, shielded internal power supply, shelf or dual rack-mount. It has RCA inputs and XLR outputs.

### MM100 Impedance Interface

Use the MM100 bi-directional stereo interface for record-playback applications interfacing audio or video cassette recorders and also for input-output matching of equalizers, NR units, reverbs and mixers. Jumper the IHF jacks to make a dual line amp, two output DA or a two input summing amp and stereo combiner. Rugged shielded enclosure, shelf mount brackets, accessory 1 3/4" rack panel mounts 2 units.

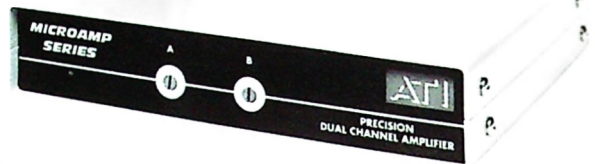

### L-1000 Dual Line Amplifier

The ATI L-1000 dual line series of Micro Amps is rackable, micro-sized, stackable, versatile and RF protected. The series provides +22 dBm at clipping for transformer and single ended outputs, +26 dBm for balanced differential outputs. They're quiet; total amplifier noise is typically within 1 dB of the thermal noise of source impedance.

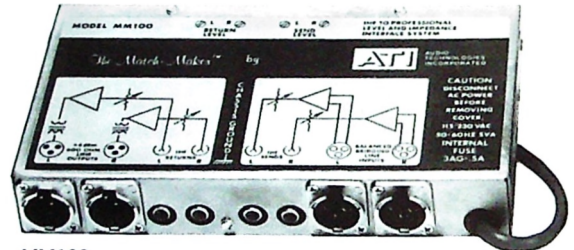

MM100

## BENCHMARK



DOA

### DOA-1A & 2A Line Level Output Amps

The DOAs provide the optimum answer to the need for a professional level interface, and at less than half the price of an external device. With the DOAs, cabling, space, mounting and AC power problems are eliminated. The DOA-1A uses a split power from  $\pm 9V$  to  $\pm 22VDC$ . The DOA-2A uses a single (+) supply from +18V to +44VDC.



DIA

### DIA-1 & 2A Differential Input Amps

The DIAs retrofit into existing equipment and may be used with virtually any existing supply voltages up to  $\pm 26VDC$  volts. These different input amplifiers provide the optimum answer for balanced inputs in your equipment. The DIA-1 uses split power supplies and the DIA-2 uses single ended.

## FIDELIPAC

### SRC Sample Rate Converter

Fidelipac's Dynamax SRC microprocessor controlled Sampling Rate Converter receives stereo digital audio signals conforming to AES/EBU, IEC 958, S/PDIF or Optical in professional or consumer mode at any frequency and outputs it at either a user-programmable sampling rate or synchronized to a second, reference digital audio signal. The Sampling Rate converter is available as a stand-alone or rack mount unit complete with external power supply and connectors. Contains a 9 pin "D" connector (RS-232 Port) for remote programming.





**LogiConverter Control Interface**

LogiConverter is an interface unit that facilitates remote control of broadcast studio equipment. It eliminates the incompatibility often encountered when a broadcast console is used to provide remote start/stop control of peripheral equipment, e.g. cart machines, CD players, tape recorders, etc. LogiConverter converts TTL/CMOS or 'open-collector' console outputs to relay closures for remote interface that is compatible, reliable and isolated. All LogiConverter inputs are opto-isolated; outputs are SPDT (Form C) relay contacts. The unit can be user programmed via internal 'dip switches' to generate either momentary or maintained outputs from various inputs, with 24 input/output combinations possible. LogiConverter will control up to 4 circuits, and can provide start-only or start-stop outputs from a single input signal.



**Matchbox Interface Amplifier**

The MATCHBOX is the ideal, inexpensive way to correctly interconnect semi-pro equipment with pro studio gear. The MATCHBOX is bi-directional, with four independent amplifiers for stereo input and output interface. Two amplifiers convert a stereo IHF HI-Z unbalanced source to LO-Z balanced outputs at studio level. A second pair of amplifiers converts the stereo balanced studio line source of unbalanced IHF outputs to feed the inputs of an IHF device. All circuitry is active and direct coupled for absolute sonic transparency.



**Superelay Control Interface**

Superelay is a multi-purpose control interface for use in broadcast station control rooms, A/V systems, or any installation requiring multiple circuit control. Superelay is ideal for controlling the various equipment functions that need to be switched when, for example, a control room mic is turned ON, e.g., EBS receiver mute, intercom speaker defeat, telephone bell disconnect, skimmer recorder start, "ON THE AIR" warning lights on, etc. Superelay can be controlled by virtually any console's muting output, or by any external switch, either momentary or maintained. It provides two types of outputs: relay and switched AC.



**Twin Match Impedance Interface**

TWIN MATCH is a four channel level & impedance interface for matching -10 dBV unbalanced equipment to +4 dBm professional gear. It's like The Matchbox, but it's "one-way," ideal for CD players. Since TWIN MATCH has four channels, one unit will work with a pair of stereo CD players, or with a four-channel tape deck. All DC-coupled active circuitry. Outputs will drive a 600 ohm load to +25 dBm. Same size & price as a Matchbox.

**Universal Turntable Controller (UTC)**

The Universal Turntable Controller is a control interface unit that adds full remote control to Technics SP10, SP15, SP25, and SL1200MKII turntables. It converts the turntable's 'single button' control logic so that separate START and STOP switches can be used to operate the turntable. The UTC also provides outputs to drive 24VDC tally lamps for use with illuminated push buttons, to show the RUN or STOP mode with absolute reliability.



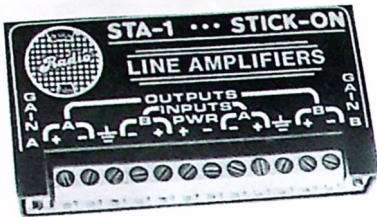

**RDL STA-1 Electronic TX & Line Amplifier**

The dual-channel line amplifier with bridging inputs, adjustable gain (or loss) and low impedance outputs is like a pair of studio transformers with gain. True DC amplifiers produce high common-mode rejection, ultra low distortion and noise. The gain is an adjustable 20db for each channel. The STA-1 requires 50mA of 24 to 36 VDC, such as the optional RDL PS-24A.

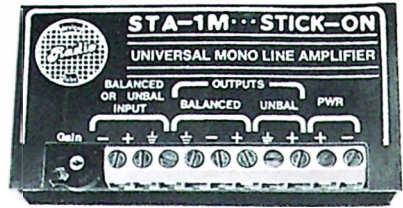

**RDL STA-1M Audio Line Amplifier**

The STA-1M is a single channel amplifier that permits you to bridge any audio line, adjust the gain and then drive a balanced or unbalanced line. The source can be balanced or unbalanced and high or low impedance. An instrumentation input helps to isolate ground loops. The STA-1M requires 50mA of 24 to 36 VDC, such as the optional RDL PS-24A.



**RDL ST-ARC Audio Controlled Relays**

Whether it is silence sensing or control switching from an audio signal, the ST-ARC series provides DPDT switching contacts actuated by audio. The ST-ARC1 switches on line level. The ST-ARC1M works on low or mic level. And the ST-ARC2 (pictured above) works with the line level and adds an extended release delay or silence sense. All have 10K ohm balanced bridging inputs. They require 50mA of 24 to 36 VDC, such as the optional RDL PS-24A.



**STD-150/STD-600 Audio Divider/Combiner**

The STD-1 is a resistive branching network with RF filtering on each of the four channels. Any channel, A through D, may be either an input or an output. This permits combining stereo signals into mono inputs, splitting mono signals to multiple inputs, and even combining microphones with output shorting switches into a single amplifier input. Available in both 150 ohm and 600 ohm. All inputs and outputs balanced. Only 2.9" x 1.5" x .5" small. The STD-1 is just one of the ultra-convenient "STICK-ON" products available.

STD-600  
STD-150

*RDL has many other problem solvers. Contact us for more details.*



**RDL STP-1 Universal Attenuator**

The STP-1 is a pair of convenient attenuator pads that can be located where you need them. Multi-turn trimmers permit precise adjustment of levels without the need to connect jumpers or external resistors. The STP-1 operates in either high or low impedance and on balanced or unbalanced circuits. Attenuation varies from 1db to 85db, depending on the type of circuit. No external power is required.

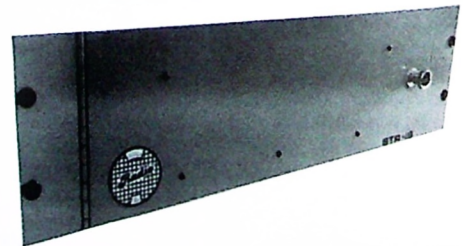

**STR-19 Racking System**

The STR-19 is a rack mount assembly which allows the installer to mount from one to fifteen RDL "STICK-ON" products. The all-steel panel is hinged for convenient access during installation and adjustment. The bottom of the panel holds a wiring duct for neat wire harnessing and routing. "Snap-on" mounts permanently adhere to each "STICK-ON," which is then quickly snapped on or off the mounting rail. The STR-19 is just one more reason to make RDL "STICK-ONS" your first source for ultra convenient, high performance electronics. 5 1/4" x 19".

*Specifications subject to change or revision.*

## ROLAND



### SRC-2 Dual Sample Rate Converter

The Roland SRC-2 Dual Sample Rate Converter provides a multitude of digital conversion and mixing features for the professional user.

The SRC-2 gives you the compability to mix 2 stereo digital signals at differing sample rates into one stereo digital output at any selectable sample rate with balance and overall level control. Features include digital "clip" indicator, L&R channel metering, and automatic "de-emphasis" and 2 digital inputs with 3 connector choices. Innumerable input/output selections. A real digital "workhorse."

## RUSS FRIEND & ASSOCIATES

### CD100-X Compact Disc Adapter-Amp

The CD100-X compact disc adapter-amplifier is specially designed to interface a consumer type CD player to the input of any audio console. It has top mounted adjustment pots and voltage regulated circuitry. The CD100-X can also be used to interface a cassette player or any high impedance output audio device.

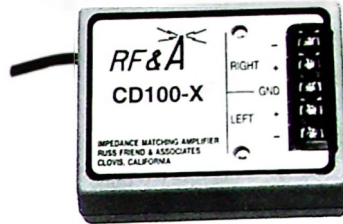

## TASCAM



### LA-40 MKII Interface Amplifier

Tascam introduces the LA-40 MKII 4-channel bi-directional balanced and unbalanced line converter. It has ground lift switches for each

independent channel and an overall master switch, with all switches on the rear panel. Plus a  $\pm 6$ dB trim pot for control of each channel. Besides being a (+4 to -10 or -10 to +4) line converter box, an unbalanced input signal, by using the "input link" feature, will allow the LA-40 MKII to also be used as a distribution amp. XLR output.

## VALLEY AUDIO

### HH2x2B Level Matching Interface

While the HH2x2B level matching interface immediately resolves the level and impedance matching problems associated with interfacing -10 dB equipment to the studio and broadcast standards of +4 and +8 dB, it also ensures immunity from RF pickup and hum, thanks to electronic balancing of the +4/+8 inputs and outputs. Rack mount available.

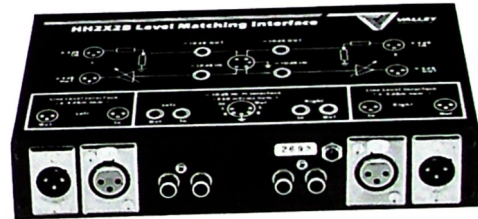

## YAMAHA



### FMC2 Format Converter

The Yamaha FMC2 is a 2-channel digital audio signal format converter ideal for connecting external digital signal processors to equipment with Yamaha format digital inputs and outputs. The FMC2 can perform the following conversions: Yamaha format to AES/EBU, CD/DAT format; AES/EBU format to Yamaha format and CD/DAT format to Yamaha format.

## ZERCOM



### GAIN BOX

The GAIN BOX was designed and built as an audio boost amplifier for many applications around the broadcast station. It has two independent channels of gain which means it can be used for stereo or as two separate monaural amplifiers. The two channels can be wired in series for up to 60 dB gain.

AKG



C414B/ULS



C3000



C5600



D-80



D-190E



D-3800

*Harris Allied carries  
the entire line of AKG  
boom and hand-held mics*

### C414B/ULS Condenser Microphone

The C-414B/ULS pressure gradient condenser microphone is a studio standard. A large diameter diaphragm capsule allows an exceptionally wide dynamic range and frequency response. A unique feature is the four selectable polar patterns on the mic. Thus, four different types of microphones are combined into one all-metal housing with a satin-black chrome finish. Three position bass-rolloff switch and three position attenuator switch. Low current consumption as well as low self noise. Includes foam windscreen, SA-18/3 clamp-type stand adapter and foam lined vinyl case. Unsurpassed for digital recordings.

### C5600 Tri-Power Condenser Microphone

The AKG C5600 is a top-of-the-line condenser microphone for live, on-stage performances. With the latest additions to the Tri-Power series, the C5600 has the new large diaphragm TPC-II™ condenser system for capturing harmonically rich textures even at extremely high volume. Which means it's equally perfect for a soft guitar ballad, Sousa march or heavy metal blowout. The C5600 has the new InterSpider™ internal suspension system to cut stage rumble or mechanical noise.

### D-80 Cardioid Dynamic Microphone

The D-80 is a cardioid dynamic microphone which was designed for both vocal and musical applications. It is particularly suited for use with high quality sound reinforcement systems and cassette decks. A foam wind and pop filter eliminates pop and breath noise, as well as wind noise when the microphone is used outdoors.

### D-190E Cardioid Microphone

The D-190E features a smooth frequency response and uniform cardioid directional pattern that produces an open, effortless sound and relative immunity to feedback even under acoustically unfavorable conditions. The elastically suspended capsule greatly reduces sensitivity to handling noise and mechanical shock.

### C3000 Studio Microphone

The AKG C3000 microphone has a warm, clean sound and delivers studio quality with a dual pattern. It also has a large condenser diaphragm system that's internally shock-mounted against vibration. The C3000 is a studio-standard mic at half the price, for professionals with a tight budget.

### D-3800 Tri-Power Vocal Microphone

The D-3800 was designed with care and attention for vocalists who don't want to settle for anything less than quality sound. The D-3800 utilizes a high-output transducer system that projects vocals with clarity and power and has a hum-suppression coil. The D-3800 solves the problem of cable and handling noise by using AKG's patented MMS™ (Moving Magnet Suspension) system to achieve a totally new level of performance in hand-held vocal microphones.

BEYER



### M58 Omnidirectional Microphone

The M58 omnidirectional moving coil microphone was designed to satisfy the demands of electronic newsgathering, ENG and EFP applications. Its sophisticated internal shockmount dramatically reduces undesirable handling noise. The frequency response has been fine-tuned to provide broadcasters with accurate reproduction of voice information with a very high degree of intelligibility.



### M88 Dynamic Directional Microphone

The Beyer M88 is a studio-quality dynamic hypercardioid directional microphone. It has an exceptionally wide frequency response and unusually high sensitivity, plus extremely low feedback and unparalleled SPL capability. For all professional applications and most demanding electroacoustical engineering specifications.





AT804



AT835A



AT4033



ATM25

## AT804 Omnidirectional Microphone

The AT804 is a wide-range moving coil dynamic microphone with an omnidirectional pickup pattern. Designed for use by professional recording and broadcasting studios for high-quality sound reinforcement and demanding voice and music sound pickup situations. Its hardened-steel grille and die-cast case make the AT804 especially useful in field applications where rugged construction is essential.

## AT835A Condenser Line Mic

The AT835A is a wide-range condenser microphone for professional use, with a lobar polar pattern specifically designed for the narrow acceptance angle desirable for long distance sound pickup. The AT835A features a balanced, low-impedance XLRM-type output connector and has a fixed-charge condenser diaphragm, and is uniquely suited for boom and hand-held use in TV and film production, ENG, outdoor nature recording, and similar specialized applications. Power is from an external 9V to 52V DC phantom supply or from an AA/UM3 1.5V battery. Harris Allied supplies Audio-Technica microphones to all types of radio and TV stations. Standard, shotgun or condenser, Audio-Technica mics are rugged and true to the original sound.

## AT4033 Cardioid Capacitor Mic

The Audio-Technica AT4033 is a transformerless, studio microphone designed for demanding applications. The AT4033 utilizes a gold-plated, "aged-diaphragm" condenser element with an internal baffle plate to increase the signal-to-noise ratio of the microphone system. This coupled with low-noise transformerless electronics, makes this microphone ideal for the most critical digital recordings. The dynamic range of the AT4033 is 123dB without the built-in attenuator and it accepts up to 140dB SPL without capsule or electronic-system distortion above 1% T.H.D. Maximum diameter 2.10" (53.4mm), and a weight of 14.5 oz. (410 grams). Black matte finish.

## ATM25 Coil Dynamic Microphone

The Model ATM25 is a wide-range moving coil dynamic microphone with a hyper-cardioid pickup pattern. Its relatively high sensitivity assures useful output and an excellent match to most mixers, tape recorders or amplifier inputs. It meets the most critical requirements of high-quality sound reinforcement systems and the needs of professional musicians, making it excellent for studio and remote broadcasting and recording. Enclosed in a rugged housing with low-reflectance matte finish. Carrying case provided.

*Harris Allied distributes the entire Audio-Technica line of microphones.*



## MT830R Sub-Miniature Condenser Mic

The Audio-Technica MT830R is a sub-miniature microphone condenser for professional applications where remote power is available. The MT830R is intended to be worn on the clothing of performers for excellent, unobtrusive sound pickup.

The wide-range capability of the MT830R ensures clean, accurate reproduction with high intelligibility for performers as well as musical instruments. Clothing clip and accessory windscreen provided.

## Pro 88W Wireless Microphone System

The PRO 88W is a lavalier wireless system with switchable frequency that operates in the 170MHz VHF band, providing better audio quality and operating range. PRO 88W systems are available on four different pairs of channels allowing several systems to be

operated at one time in multiple-input applications.

Attaches to a belt or slips into a pocket. Excellent for schools, boardrooms, churches and camcorders.





635A



DO56



RE15



RE50



RE38N/D



RE27N/D



RE20

### 635A Omnidirectional Microphone

The 635A dynamic omnidirectional is the most popular and well known ENG/EFP microphone in the world. The 635A's "tailored" frequency response delivers clean audio under adverse field conditions. The unsurpassed ruggedness and durability of the 635A has earned it a nickname, "The Hammer." Also available in black (635A/B).

### DO56 Omnidirectional Microphone

The DO56 is a shock-mounted omnidirectional microphone for hand-held broadcast and sound reinforcement applications. All handling noises and cord vibration are isolated from the microphone element. A slim, attractive silhouette and the silver tone beige finish are ideal for on-camera use. -61dB output/80 Hz to 18 kHz.

### RE15 Super Cardioid Microphone

The RE15 is super cardioid with 80 Hz to 15 kHz frequency response and -56dB output. An excellent "on stage" microphone.

### RE20 Cardioid Microphone

The RE20 dynamic cardioid microphone features a Variable-D® design that virtually eliminates "bass boosting" (proximity effect) and produces a smooth, extended clean response. Features include a bass roll-off switch and an internal microphone element shock-mount that reduces vibration-induced noise. One of the most popular broadcast announce and voice-over microphones today.

### RE27N/D Dynamic Microphone

The RE27N/D utilizes the time-proven Variable-D® concept pioneered by the legendary RE20, but incorporates N/DYM™ technology to create a dynamic microphone that exhibits higher output and even wider frequency response than the industry-standard RE20. The RE27N/D features three switchable filters and an internal blast/wind filter that covers the microphone head/vents along the mic body, preventing P-pops, breath sounds or excessive sibilance.

### RE38N/D Large-Diaphragm Dynamic Mic

The RE38N/D is a large-diaphragm dynamic microphone with highly effective internal shock-mounting called DynaDamp™. The microphone head pivots on a yoke for exact and flexible positioning. The N/DYM® technology provides high sensitivity for a superior signal-to-noise ratio and a 16-position equalization switch tailors the sound of the RE38N/D to a variety of needs.

### RE50 Shock-mounted Microphone

The RE50 shock-mounted dynamic omnidirectional was designed specifically as an ENG/EFP interview microphone. The RE50's custom "mic-within-a-mic" shock-mount provides extremely low handling noise for superior sound. A large, built-in Acoustifoam™ filter keeps wind and P-pop noise to an absolute minimum, indoors and out. Also available in black (RE50/B).

*See Page 110 for Electro-Voice Lavalier and Miniature Microphones.*

RE27N/D RE38N/D



# A New Generation of Broadcast Legends



Leading-Edge Broadcast Technology from a company known as a market leader for over 40 years

## ELECTRO-VOICE

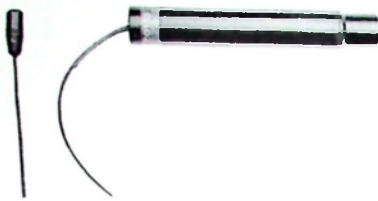
**CO100 Omnidirectional Lavalier Mic**

The CO100 omnidirectional lavalier has exceptionally clean, accurate sound. designed for the rigors of the field and news production, the CO100 is extremely durable. Accessories included are: 10' cable attached to a steel tube battery housing; a single-loop tie clasp and a wind/pop screen. One standard AAA battery or an external 9-52 volt phantom supply powers the CO100.

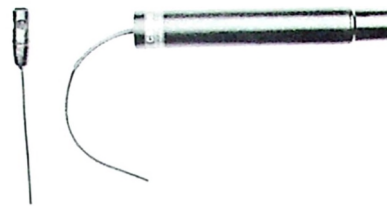
**CS200 Unidirectional Lavalier Mic**

The CS200 unidirectional lavalier has the same clean, accurate sound reproduction and rugged design as the CO100. The CS200's tight pickup pattern helps eliminate unwanted noise and feedback. A single-loop lavalier tie clasp and windscreen are included. One standard AAA battery or external 9-52 volt phantom supply powers the CS200.



CP212/CP218  
Miniature  
Gooseneck  
Microphone

**CP212/CP218 Miniature Gooseneck Mic**

The CP212 (12") and CP218 (18") miniature gooseneck microphones are designed for broadcast and production control-room consoles, communication consoles, award podiums and lecterns. Both are phantom powered with a "back-electret" design that provides wide-band response and high output. Two independent, movable joints on the gooseneck prevent unsightly twists while allowing exact positioning.

## NEUMANN

**TLM50 Pressure Microphone**

The TLM 50 is a pressure microphone with transformerless electronic circuitry. Modern TLM circuitry yields a phenomenal low self-noise and a much higher SPL handling capability, resulting in a dynamic range of 123 dB. This is 29 dB above the theoretical dynamic range of any CD. The TLM 50's fast transient response and extended frequency response are excellent prerequisites for digital recordings. The TLM 50 is addressed from the side and can also be mounted in an EA 50 elastic suspension which is a separate accessory.

**TLM170 Switchable Microphone**

The TLM 170 switchable microphone features symmetrical, transformerless signal decoupling and maximum loadability with extremely low self-noise. Five directional characteristics are selectable: omnidirectional, wide-angle cardioid, cardioid, hypercardioid and figure 8. The microphone is equipped with tiltable, elastically suspended bracket which effectively isolates it from mechanical noise.

**TLM 193 Condenser Microphone**

The Neumann TLM 193 is a large diaphragm, double membrane cardioid condenser microphone designed for critical recording, broadcast and live sound applications especially in large facilities. Offering a value-conscious package, the TLM 193 has ultra-low self noise (10dB-A), high sound-pressure capability (140dB before overload), wide dynamic range (130dB), wide frequency response (20Hz - 20kHz) plus quality, durability, longevity and glorious sound. Includes swivel-mount and foam-lined wooden jeweler's case.

**U87AI Condenser Microphone**

The solid state condenser microphone model U87AI is the best known and most widely used of the fet-80 series. The dual membrane capsule uses evaporated gold on polyester film which has proven to be the most heat and aging resistant material. Three switches are provided beneath the capsule itself: for selecting the three directional characteristics, frequency response and sensitivity. Its high frequency response is practically linear even in its cardioid and figure-8 positions.



MD421U-LC



MD441U



MD511/512



MKH416-P48U3



MKE300



MKE4032-P3



MD515/516

## MD-421U-LC Cardioid Microphone

The Sennheiser MD421 microphone has superb directionality and freedom from overload to more than 175dB—from 30 to 17,000 Hz. This is the microphone for today - a broadcast standard! Ruggedly constructed and reliable. Its pressure-gradient dynamic transducer provides faultless performance. Also incorporates a five-step adjustable bass attenuator. Unit is less cable.

## MD-441U Supercardioid Microphone

The Sennheiser MD441 is the universal microphone with the studio quality for demanding soloists and instrumentalists. It is acknowledged as the most accurate dynamic mic available. It has a nearly textbook perfect supercardioid pattern, a five position low frequency contour switch, a two position high frequency switch, a critically damped internal shock suspension and a hum bucking coil.

## MKE4032-P3 Supercardioid Microphone

The lightweight Sennheiser MKE4032 is designed for vocal use on stage. It offers the sensitivity and transparent high end of a condenser as well as the ability to handle sound pressure levels of 1140dB. The supercardioid pattern is highly insensitive to feedback. Includes a low frequency roll-off switch and 3-position output attenuator. Use it for close mic'ing vocals. Rugged construction with dual screen basket and black metal body.

## MKH416/P48U3 Supercardioid Mic

The Sennheiser MKH416/P48U for phantom powering is a highly directional "shotgun" mic workhorse with a combination pressure

gradient transducer and interference tube microphone. This gives it a cardioid pattern at low and medium frequencies with a more directional club-shaped pattern at high frequencies. Its a problem solving, long distance mic.

## MKE300 Video Supercardioid/Lobar Mic

The MKE 300 with electret condenser microphone element delivers sonic clarity and high output. Ideally suited for mounting on camcorders, with an integrated shoe assembly, the MKE 300 is compact and extremely lightweight (60g/2.1oz.). With a tight, supercardioid polar pattern the microphone has the ability to pick up only those sounds that correspond to the scene being filmed and rejects any disturbing ambient noise. Has its own built-in battery.

## MD511/MD512 Cardioid

The glass composite housing makes this a natural for performance. The proximity effect has been optimized and the frequency response tailored for excellent intelligibility. It has Spring Capsule Suspension isolation to reduce handling noise. The MD512 adds a noiseless ON/OFF switch.

## MD515/MD516 Supercardioid

The mics have a hexagonal grille for acoustic transparency. They have precise supercardioid patterns for outstanding gain before feedback and the ability to handle high sound pressure levels. The body is glass composite and the capsule is isolated from handling noise by Spring Capsule Suspension. A noiseless ON/OFF switch is included on the MD516.

*See Page 112 for the Sennheiser® KS Modular Electret System.  
All Sennheiser microphones are available through Harris Allied. Call today!*



KS Modular Electret System

### Sennheiser® KS Modular Electret System

This rugged system converts quickly from one type of capsule to another by simply threading together the different components. All capsules use back-electret technology. The output of all powering modules is balanced 200 ohms with a standard XLR connector. The **K6** powering module works on a single "AA" battery or phantom power. The **ME62** is an omnidirectional module with an integrated windscreen. The **ME64** is a tight directional cardioid pattern with high gain before feedback. The **ME66** short shotgun is a combination of supercardioid at low frequencies and shotgun above 200Hz, making it good for on-camera ENG/EFP use. The **MKE2-60** omnidirectional

lavalier provides an open natural sound in an extremely small size. The **MKE102-60** (not pictured) is an omnidirectional lavalier with natural sound and high intelligibility. The **MKE40-60** (not pictured) cardioid lavalier is for applications where isolation from ambient noise is needed and/or increased gain before feedback. A swivel mount makes for easy positioning.



MKE2-60

## SHURE

### Wireless L Series System

The **L4** exclusive MARCAD™ circuitry combines the two RF signals when both are usable, providing improved signal-to-noise ratio. The **L3** Receiver has removable, insulated ¼-wave whip antenna and is rack-mountable with accessory kit. Step-up ½-wave antenna and remote cable kit are available for both the **L4** and **L3**.

The **L Series** hand-held transmitters feature outstanding audio quality, durable, lightweight and compact construction, enclosed loop antennas and easily interchangeable heads.



### WCM16 Wireless Mic

Additional wireless mics also include the **WCM16** wireless headworn condenser microphone.



WCM16

The **L11** Body-Pack Transmitter has an ultra-compact design using reliable surface-mount construction, extended battery life (14-20 hours) plus Mirror Image™ com-

manding circuitry which extends the dynamic range. The universal input connector accepts a variety of mics, such as the **839W Lavalier** shown here.



SM84

### SM84 Condenser Microphone

The **SM84** condenser mic is designed for professional broadcasters. Featuring a wide-range of frequency responses and tailored to provide more natural sound. Easily clips onto a belt or slips into a pocket. Powered by 9-V battery or simplex power from an external source. The **SM84** is unidirectional, the **SM83** is omnidirectional.

### SC Series Wireless System

**SC2** Hand-held transmitter with interchangeable mic element.



**SC4** MARCAD™ Diversity Receiver with rack-mounting hardware and antennas



**SC1** Body-pack transmitter with detachable lavalier mic.

### SC Series Wireless

The Shure **SC Series** wireless microphone system is a frequency-selectable diversity system operating in the VHF band between 169 and 210 MHz. Each **SC Series** system is capable

of operating on 8 different frequencies. Digital frequency control enables the system to produce a clean signal, which allows up to 12 **SC Series** wireless systems to be operated simultaneously in a single installation.



SM7



SM11CN



SM81LC



SM57 LC/CN



SM58 LC/CN



VP64



VP88

### SM7 Dynamic Microphone

The SM-7 designed in conjunction with professional users, is among the finest studio professional dynamic microphones in use today. Its "smooth and silky" sound has made it extremely popular for voice-over recording in radio and television. Announcers love its "mellow" sound. Supplied less cable.

### SM11CN Dynamic Lavalier Microphone

The Shure SM11CN is the smallest dynamic lavalier microphone available. Shure ruggedness and dependability in a microphone no longer than a paperclip. Comes with tie tack and tie bar mounting accessories. Omnidirectional.

### Shure SM57LC/CN Unidirectional Mic

The unusually effective cardioid pick-up pattern of this dynamic mic minimizes effects of studio or location acoustics and background noises. Read and side rejection is uniform to very low frequencies. It has a bright, clean sound and is especially effective for announcing and interviews. The CN is supplied with a 25 ft. cable with connectors on both ends. The LC is the same mic but without cable or connectors.

### Shure SM58LC/CN Unidirectional Mic

Here is a rugged unidirectional dynamic microphone with a highly effective built-in wind and pop filter. The unusually effective cardioid pickup pattern minimizes background noises and undesirable effects from location acoustics. The mic has a bright, clean sound and the cartridge is shock mounted for protection and quiet operation. The CN is supplied with a 25 foot cable with connectors on both ends. The LC is the same mic but without cable or connectors.

### SM81LC Unidirectional Condenser Mic

Now you can have the high performance of a condenser with the ruggedness of a dynamic. The SM81 is built to withstand a minimum of 6 drops from 6 ft. (1.8m) onto a hardwood floor. The high signal-to-noise ratio and unidirectional pattern offer outstanding reach and unparalleled separation and it has ultra-flat frequency response. Supplied without cable.

### VP64 Studio and Field Microphone

The Shure VP64's sleek, ergonomic design and a high-energy neodymium magnet make the VP64 perfect for "on-camera" video production and broadcast use. The upper-midrange presence rise adds clarity, while the low-end roll-off minimizes boominess and background noise. The VP64 has consistent audio quality on or off axis, high output, low noise, effective shock isolation and extremely rugged construction. Windscreens and swivel adapter supplied. Omnidirectional dynamic. Frequency response: 50 to 12,000 Hz.

### VP88 Stereo Microphone

The VP88 is a single point stereo (MS configuration) condenser mic that recreates the sonic environment as few other mics can. The 3 switch-selectable levels of stereo effect allow you to control the degree of "spread" and ambiance pickup. Mounting of the VP88 is versatile with equal ease on a camera, floor stand, fish pole, boom or hand-held. Supplied with a 30" multi-connector Y cable and 25' extension cable.

## VEGA

### Vega VX-20 Wireless System

For video production, ENG, EFP and all portable wireless applications, the ideal choice is the Vega VX-20 system with its clear, crisp, natural audio. The system consists of the miniature R-27 camera-mountable receiver and the T-25 body-pack or T-28 or T-29 hand-held transmitter. The VX-20 system was designed for portable wireless system users who require exceptional audio performance in a compact, rugged configuration. Features include: Ten poles of IF filtering, full-size XLR audio output, front-panel audio monitor with independent gain control, 8 hours of operation with one 9-volt battery plus rugged aluminum case.

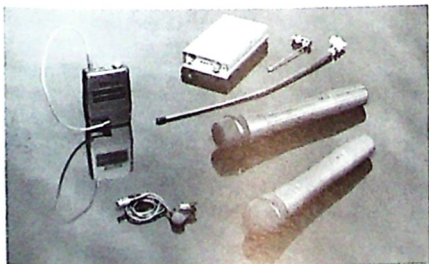

Certain products not available in some areas.



WRR-840A UHF Dual Synthesized Diversity Tuner

**Sony 800 Series UHF Wireless System**

Discover the superb quality of wireless performance that's available in the Sony UHF (800 MHz) wireless system. All transmitters and receivers offer 94 selectable frequencies across 2 UHF channels, allowing up to 19 simultaneously operating transmitters on a single pair of antenna. Each antenna can be wall-mounted or stand-mounted. Transmitters are available with dynamic or condenser hand-held mics or in compact body pack accepting any microphone. The receivers are available in rack-mount or portable versions. The 800 series UHF wireless system offers flexibility, durability, great performance and a proven track record at a very competitive price.



WRT-810A UHF Wireless Microphone Transmitter



WRT-820A UHF Body Pack Transmitter

TELEX



**Telex® FMR-70 Wireless Mic System**

The FMR-70 is a part of the Telex Pos-i-Phase™ series that provides high quality true diversity operation at an entry-level price. Pos-i-Squelch™ prevents annoying interference when the transmitter is turned off. Front panel LEDs include diversity, RF carrier and a four segment audio level indicator. There are several belt pack and hand-held transmitters that work with the FMR receivers.



**Telex® FMR-100 Wireless Mic System**

The FMR-100 receiver is a true diversity unit which has an improved front end. Its IF strip features linear phase filters that are computer matched before assembly to minimize distortion causing group delay. A Pos-i-Squelch™ system uses a noiseless relay to eliminate pops & static. Both RF and audio strength can be monitored from the front panel LED indicators. Up to 18 systems can be operated in a single location simultaneously.



**Telex® FMR-450 Wireless Mic System**

The Telex FMR-450 makes professional quality available in the UHF wireless band. The new FMR-450 offers the performance benefits of operating in the less congested UHF band from 524 MHz to 746 MHz. You can operate up to 50 systems simultaneously.



**Telex® ENG-1 Portable Wireless Receiver**

Designed for use with video cameras, the mini ENG-1 offers VHF performance in an ultra-small package with a weight of only 5.5 oz. (156g) including 9V battery. In addition to the headphone output with separate level control, the main output is both balanced and unbalanced with its own level control LEDs indicate low battery, transmitter on an audio overload. It is compatible with all Telex belt pack and hand-held transmitters.



## ATI



### VU1000 Line Switcher Monitor Amp

Capable of many functions, use the VU1000 as an input line selector, a remote line selector into your console and for general metering and monitoring of critical signals. Eight balanced bridging inputs are panel and remotely selectable to feed an LED bargraph meter with both VU and PPM ballistics plus a balanced line output and a headphone jack. A range switch sets the reference line output and 0VU indications for five levels from -10 to +18 dBm. An optional built-in 6 watt power amp drives external speakers. Interconnect 2 for slaved stereo switching.

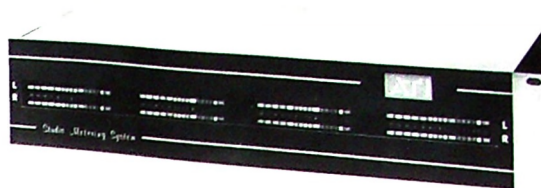

### VU200, VU400, VU600, VU800 Audio Monitor

Give yourself that warm, secure feeling by economically displaying all your important lines simultaneously. Know at a glance where your signals are (or are not). Expandable ATI MicroMeters display one, two, three or four stereo lines (eight channels) on bright, two color vacuum fluorescent bar-graph indicators. Balanced, bridging inputs are switchable for 0VU at -10, +4 and +8 dBm line levels. Displays -20 to +8VU with peaks stored for several seconds. Backlit, compact 3 1/2" rack mount.

## B & B SYSTEMS

### AM-2B Phase Scope

The Phasescope AM-2B gives a complete "picture" of the stereo audio signal at a quick glance. For AM and FM stereo radio broadcasters and sound recording studios, the AM-2B features CRT X/Y display of stereo audio phase, LED display of peak audio levels for left and right channels showing headroom availability, VU level meters for left and right channels, and magnetic and EMI/RF shielding. The space-saving AM-2B in two EIA rack units weighs 20 lbs.



## CARVER



### TX-11b FM/AM Stereo Tuner

The Carver TX-11b FM/AM Stereo Tuner offers low noise, less distortion, superior sensitivity and far better rejection of multipath interference assuring you of high-quality reception. The TX-11b's great performance is due to Carver's exclusive ACCD (Asymmetrical Charge-Coupled Detection) circuit. ACCD "extracts" clean stereo music from weaker FM signals. Where AM stereo is available, the TX-11b will capture and reproduce those signals as well. Features include: auto/manual scan selection; 13 presets, 3-week memory backup and more.



### PSC-60 Tuner/Preamplifier

The PSC-60 is a one rack-space FM/AM tuner/preamplifier with a total of (5) high level inputs, (1) phono input, tape dubbing facilities and Carver's patented ACCD (Asymmetrical Charge-Coupled Detection) FM tuner circuitry. This versatile preamp/tuner offers outstanding performance and flexibility at a very reasonable cost. Features include: 20 FM/AM presets; ACCD multipath and noise reduction circuitry, preset scan; auto/manual tuning; 3-LED signal strength meter and moving magnet phono pre-amplifier stage.

## DAVTRONICS

### RFA-5 RF Amplifier

The RFA-5 AM RF amplifier is designed to operate frequency and modulation monitors at a location remote from the transmitter, typically at the studio. When driven by a local antenna with an RF signal as low as 0.6 mv, the RFA-5 will drive most contemporary AM monitoring equipment, as well as provide a low-level output for an oscilloscope, and a clipped/limited output for a standard frequency counter.





### AMM-2B AM Modulation Monitor

The AMM-2B modulation monitor sets standards in accurate AM monitoring. It's the first AM monitor to incorporate true ratio-type peak indicators. The AMM-2 contains a unique modulation cancellation scheme to recover unmodulated carrier to reference the modulation peaks to.



### AMM-4 AM Frequency Monitor

The AMM-4 frequency monitor is designed especially for ATS. Any frequency from 10 kHz to 50 MHz may be monitored for deviation.



### FMM-2 FM Modulation Monitor

The FMM-2 is the first to incorporate a sample hold peak modulation meter circuit independent of modulation polarity to allow the meter to respond to program peaks of the shortest duration. The heart of the FMM-2 is an ultra-linear digital discriminator which provides a distortion-free baseband signal for accurate monitoring as well as precise stereophonic and SCA decoding.



DIGITAL

### FMMA-1 FM Wizard Modulation Analyzer

Belar's The Wizard FM digital modulation analyzer is feature loaded. Menu driven - 16 character alphanumeric display; deviation in 0.1 kHz increments; self calibration to external calibrating signal; silent sentry alarm on menu; modulation adjustment on 2 ports in 0.5% increments; RS-232 port; 3-level password protection and much, much more!



### FMRR-4 FM Rebroadcast Receiver

The Belar FMRR-4 Frequency Agile FM Rebroadcast Receiver is a microprocessor controlled, tunable receiver designed for rebroadcasting and other applications that require accurate FM reception and composite output. Features 10 memory locations for one-button access to 10 stations with call letters.



### AMM-3 AM Modulation Monitor

The AMM-3 modulation monitor is basically the same as the AMM-2B except for an ability to read both positive and negative modulation peaks.



DIGITAL

### AMMA-1 AM Wizard Modulation Analyzer

The Belar Wizard AMMA-1 is a microprocessor controlled, digital AM modulation monitor/analyzer that precisely measures positive and negative peak modulation, peaks per minute, average peak modulation, modulation density and more. RS-232/RS-422 port. Built-in loss of modulation alarm.



### FMM-4A FM Frequency Monitor

The FMM-4A is a digital FM frequency monitor designed especially for automatic broadcast transmitter monitoring. The counter will accurately monitor any frequency from 50 MHz to 150 MHz. A large 3½ digit LED readout provides a display range of 19.99 kHz deviation from the assigned channel. The monitor also provides two off-frequency alarms.



### FMRR-1A FM Rebroadcast Receiver

The Belar FMRR-1A FM Rebroadcast Receiver is a crystal-controlled, fixed-frequency receiver designed for use in rebroadcasting and other applications where accuracy is required. It features the same sophisticated, multistage filter as the RFA-1A and RFA-4A. Suitable for rebroadcast of mono, stereo and SCA signals.



### FMS-2 FM Stereo Modulation Monitor

Working in conjunction with the FMM-2, the FMS-2 offers two independent peak modulation meters for simultaneous monitoring of left and right channels or L+R and L-R. It also has two independent auto-ranging voltmeters with LED displays.

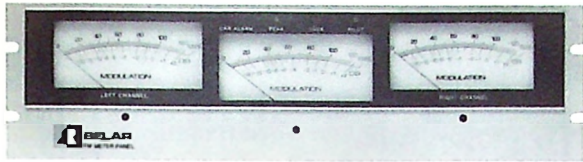

**MP8/MP9/MP10 Remote Meter Panels**

The MP Remote Monitor Meter Panels are available for Belar AM, FM and TV monitors to remotely duplicate meter displays.



**RFA-2 AM RF Amplifier**

The RFA-2 AM RF amplifier offers a selective, high gain, all silicon solid-state unit with AGC and makes it possible to monitor off-the-air AM signals accurately and conveniently without the problems associated with changes in transmitter power level, antenna patterns and signal fading. The RFA-2 when used in conjunction with AMM-2B, AMM-3 or AMM-4 allows monitoring of modulation characteristics at a remote point.



**RFA-4 FM RF Amplifier**

The RFA-4 is a synthesized tunable RF amplifier with an IF output compatible with the Belar FMM-2 FM modulation monitor. The RFA-4 allows the user to store up to 10 different FM frequencies in memory and select between them at the push of a single button.



**SCM-2 SCA Modulation Monitor**

The SCM-2 SCA modulation monitor, when added to the FMM-2 provides complete monitoring and test functions for SCA storecasting, data transmission and remote telemetering applications. Up to four crystal switch positions allow four channels to be operated and tested.



**TVM-100 TV Aural Modulation Monitor**

The Belar Model TVM-100 Television Aural Modulation Monitor is a precision wideband monitor designed to measure the total modulation characteristics of mono as well as multi-channel television audio. Utilizing split sound and quasi-parallel detection modes, automatic deviation calibrators for 25 kHz (mono) and 73 kHz (BTSC Stereo) and a digital display for indication of actual deviation, the TVM-100 satisfies all requirements for mono and stereo baseband monitoring and test.

*Belar model TVM-200 is also available for stereo applications.*

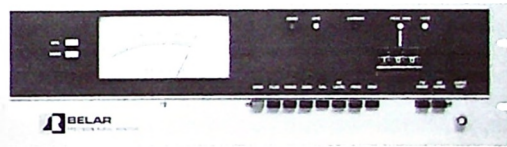

**TVM-101 TV Aural Modulation Monitor**

The Belar model TVM-101 precision aural monitor is a wide-band TV aural modulation monitor designed to measure the total modulation characteristics of mono as well as multi-channel television transmitters. Designed to conform with the latest EIA/BTSC standards, the TVM-101 is also used as a low-distortion, low-noise main channel demodulator for driving audio monitor amplifiers and audio distortion analyzers at proof time. Wide band composite outputs are provided for Stereo, SAP, PRO and SCA monitors.

*Harris Allied carries the complete line of Belar's TV monitors for mono and stereo aural applications.*

**TVM-200 TV Stereo Modulation Monitor**

The Belar TVM-200 TV stereo modulation monitor system consists of two separate units; the TVM-210 BTSC reference monitor and the TVM-220 BTSC program monitor. The TVM-210 is designed to cooperate in conjunction with the Belar TVM-10 TV aural monitor or other precision wide band demodulators. The TVM-220, when used with the TVM-210 and the TVM-101, provides full-time monitoring of L + R and composite signal modulation levels. Both functions include digitally selectable peak indicators along with fixed 1100% peak modulation indicators.

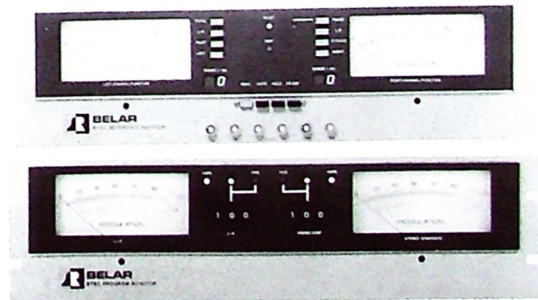

TVM-200

## DELTA

**SM-1 AM Splatter Monitor**

The model SM-1 AM splatter monitor provides AM broadcast engineers with a means of accurately and easily measuring their station's off-channel emissions to ensure compliance with the FCC regulations and NRSC. This instrument provides many of the features of an expensive spectrum analyzer at a significantly reduced price. 5¼"H x 19"W x 12"D. Shipping weight: 14 lbs.



## DORROUGH

**40A Loudness Monitor**

This meter offers a solution to the problem of inconsistent loudness that results in varying discrepancies of end product. It features a dual function on a single LED display. The LED bargraph shows normally weighty RMS material which the operator is directed to hold at center 0 dB, and a dot mode for peak indication which has a normal operator range at +13 dB. Red LEDs are at these two maximum points and the operator simply adjusts level up to the red. Equal perceived loudness is achieved by riding maximum gain to either point of reference.

**1200 Stereo Signal Test Set**

Dorrough's model 1200 is ideal for FM stereo, recording, duplicating, uplink and stereo television applications. This simple and easy to operate gain set allows stereo measurements of level, balance, crosstalk, and signal-to-noise over the entire dynamic range of your system from noise floor to clipping. The solution for balanced stereo lines.

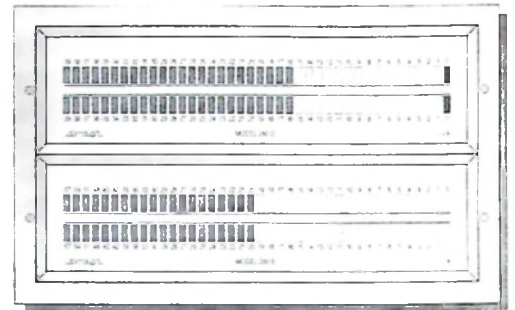

*The above illustration shows an example of the horizontal meters, Models 280-D and 280-E. Vertical meters are also available, Models 380-D and 380-E.*

**280/380 2-Channel Digital Audio Meter**

The Dorrough Models 280 (*horizontal*) and 380 (*vertical*) AES/EBU 2-channel digital-reading audio meter feature AES/EBU inputs; 2 channels per meter; simultaneous display of peak and perceived power; selectable peak-hold function; over indication; 40dB range (Model 280/380D) or 60dB range (Model 280/380E); gate-array technology; console or panel mount; screw terminals and fits standard 1.5" console openings (minimum 5.0" height and 5.2" depth). Requires external power (12 - 24 Vdc, 0.5A).

## HARRIS

**AM-90 Medium Wave Modulation Monitor**

The Harris AM-90 Medium Wave Modulation Monitor is designed for continuous monitoring of the amplitude modulation envelope in the 450 kHz to 30 MHz frequency range. An easy-to-read neon bar display accurately measures carrier and modulation levels. Two fixed flashers are adjusted to +125 percent and -100 percent for constant monitoring of modulation levels. Carrier and modulation alarms illuminate when carrier amplitude drops below 50 percent of the preset level or when modulation remains under 10 percent for ten seconds. The unit is available with a remote meter panel.

*Yes, we still have turntables!  
Call for price and models still available.  
For furniture and more studio accessories see pages 79-96.*

## INOVONICS



### 222 AM Processor

Inovonics' 222 is an NRSC audio processor specifically intended for AM broadcasting. It incorporates an adaptive pre-emphasis characteristic to enhance signal intelligibility and presence and a sharp cutoff low-pass function to eliminate adjacent channel interference. Also includes a sophisticated Peak Limiter for stand-alone service between program source and the transmitter. Also available with different cutoff frequencies for medium and short wave broadcasting.

### 550 Sentinel - Program Audio Monitor

Inovonics has taken the guesswork out of off-air program audio quality monitoring. The Sentinel Program Audio Monitor analyzes, evaluates and displays key parameters of the broadcast signal to help you make intelligent decisions regarding day-to-day station operation. Monitor, evaluate and compare key quality parameters of any station in your market.

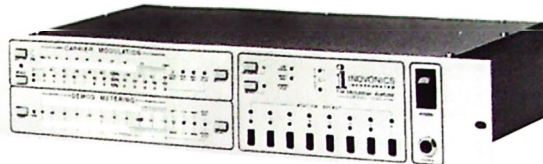

### 530 FM Modulation Analyzer

Inovonics' Model 530 combines a laboratory-grade FM receiver with highly accurate demodulation and metering circuitry for precise measurement of FM broadcast carrier modulation. Total Modulation is clearly displayed. The level of the incoming RF signal and any contribution of multipath components are quantified and displayed.

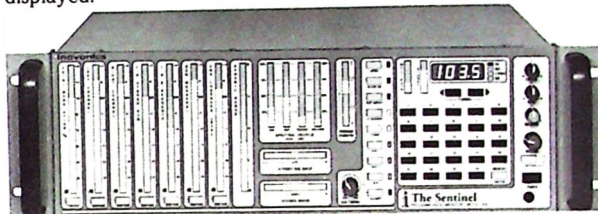

## MAGNUM DYNALABS

### Pro 101 FM Tuner/Monitor

The basic Pro-101 features a wide band composite FM output with sufficient drive for direct connection to an FM exciter and can be used as a relay receiver. Among the options are demodulated SCA outputs at 67 and 92 kHz, an alarm for both carrier and modulation loss and a balanced audio output. The front panel meters provide a continuous readout of RF input and relative multipath interference levels. The third meter is for accurate center tuning.



## MODULATION SCIENCE



### ModMinder™ Modulation Monitor

ModMinder™ is the first digital device for measuring and displaying peak FM deviation. ModMinder's advanced, highly accurate circuitry ensures that FM stations get all the modulation they're entitled to. Fully remoteable, ModMinder includes a software package that adds remote control, display and analysis capabilities from any modem-equipped PC. Optional Analysis software generates graphic displays of any FM signal — your own or the competition's. The internal Demodulator Board option makes ModMinder a standalone peak modulation monitor of unprecedented stability and accuracy.

## QEI

### 691 FM Monitor/Test Set

The 691 FM monitor/test set is a high technology, precision instrument employing a combination of new techniques in a single, highly versatile, but very compact package. It is a complete FM test package with facilities for all proof-of-performance measurements and a wide range of trouble-shooting tests. Operator convenience and simplicity of use were primary considerations in the design of the system. It occupies only 10½" of vertical rack space in a standard 19" rack.

691 modulation monitor/test set

691/01 modulation monitor/test set with 1 SCA

691/02 modulation monitor/test set with 2 SCA

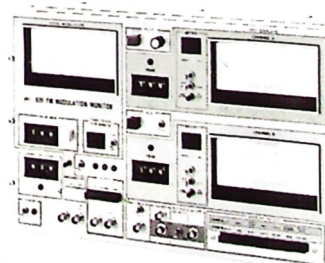

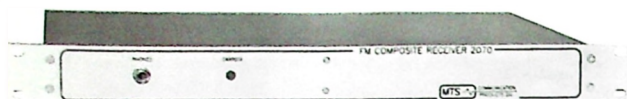

MTS 2070

### MTS 2070 FM Composite Receiver

The 2070 is fixed frequency single conversion FM composite receiver in a single RU of space. There is a front panel carrier present indicator with a relay output on a DB-9 rear connector. The composite output is on a BNC with up to 4 V P-P across 2k and an input sensitivity of greater than 10uV for 26dB SINAD.

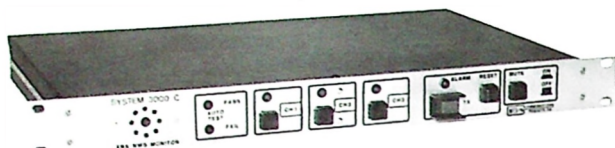

### System 3000C EBS Monitor

The System 3000C incorporates three monitor receivers, the EBS encoder and decoder into one unit. A single System 3000C can monitor your area's CPCS1, CPCS2, and the local NOAA weather service. Or it can monitor your CPCS1, CPCS2, and an adjacent area CPCS1! Or with 2 or more systems you can monitor EBS and NOAA services over a large area thereby offering your community the best information and protection available. Continuous self-test keeps you informed of system status.

Additional features include: three channel scan, continuous automatic self-test, program audio loop through, NOAA weather service receiver option, NOAA priority alert decoder option, and left and right channel outputs.



### System 1000 EBS Monitor

The System 1000 EVS monitor, from Multi-Technical Services, is an integrated Emergency Broadcast System monitor. The System 1000 incorporates the EBS encoder, the decoder, and an FM receiver all in the same single rack space enclosure.

The System 1000 offers many of the advanced EBS features found in the System 3000 such as: continuous automatic self-test, full program audio loop through, digital remote control, stereo outputs, independent encoder output, alarm relay, and HI-Z RX monitor port. Specify receiver frequency when ordering.

## POTOMAC

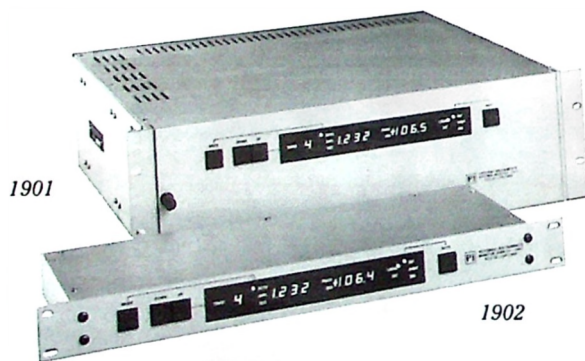

1901

1902

### 1900 Series Digital Antenna Monitors

The basic Model 1901 (upper unit) is a 5 1/4" unit which can contain control and measurement circuitry for up to 12 towers, digital display of all measurements, local operating controls and an interface to a remote control system.

The Model 1902 Monitor Display (lower unit) contains a duplication of the display and control circuitry from the Model 1901 in a 1 3/4" unit.

A Model 1903 (not pictured) is equivalent to a Model 1901 but does not contain any front panel control or display circuitry, allowing that to be performed by a Model 1902 or remote control system.

### Potomac Field Strength Meters

These FIM series of portable units are designed for precision measurements of electromagnetic fields from 200 kHz to 960 MHz. They consist of a battery operated, laboratory quality, super-heterodyne tuned voltmeter, precision attenuator, precision reference antenna and an internal calibration source.

The models FIM-22 & FIM-41 cover the LF, MF & HF bands and feature a built-in loop antenna as part of the monitor case. The FIM-71 & FIM-72A cover the 45 MHz to 225 MHz and 470 MHz to 960 MHz bands and use a supplied half-wave dipole antenna.

- FIM-22 200-550 kHz
- FIM-41 540-5000 kHz
- FIM-71 45-225 MHz
- FIM-72A 470-960 MHz

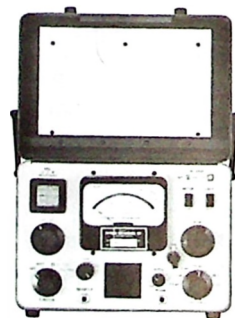

**Potomac has other test equipment available through Harris Allied.**

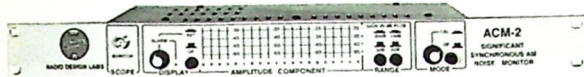

## ACM-2 AM Noise Monitor

IRDL's ACM-2 is the *only* time-proven, industry accepted method

of controlling significant synchronous AM noise. The ACM-2 allows you to maintain clarity, maximize loudness, maximize stereo separation, reduce subcarrier crosstalk, have positive control over multipath artifacts; assure consistency of your signal coverage and maximize performance from your transmitter.

## TFT



## 1844A FM Stereo Modulation Analyzer (Upper)

Complete stereo and proof-of-performance measurement capability in one unit. Dual channel, frequency agile preselector, multipath detector, built-in modulation calibrator and alarm circuits. Continuous display on 3 analog meters of Total Modulation, Left/Test and Right Channel Option for RDS level indication.

## 1845 SCA Modulation Monitor (Lower)

Three Crystal controlled frequencies are controllable from the front panel. A 67 kHz SCA channel and 75 microsecond de-emphasis are supplied. Modulation calibration accuracy is greater than 1%. Optional RF preselector and dedicated service channels available.



## 850 BTSC TV Aural Modulation Analyzer

This menu-driven instrument will measure all critical BTSC stereo signal characteristics with the push of a button. Features include a built-in precision BTSC demodulator, true peak modulation differentiation circuitry, built-in calibration, RF, IF and composite inputs. Option noise and distortion analyzer. Specify channel.



## 855 PRO/SAP Channel Modulation Monitor

Independent PRO/SAP channel sections monitor modulation and injection as defined by EIA/BTSC standards. Switchable dBx decoder or 75 microsecond de-emphasis for SAP channel and switchable de-emphasis for PRO channel.



## 1884 FM Stereo Modulation Monitor

This single channel, frequency-agile unit has two analog meters with which to measure L + R, L-R, pilot injection and total modulation. Complete FM Stereo measurement at an attractive price. Option for RDS level indication.



## 886/887 EBS Systems

Models 886 and 887 Emergency Broadcast System (EBS) encoder/decoder systems are designed for broadcasters to meet FCC rules and regulations.

The AM receiver, Model 886, is tunable across the AM broadcast band. Tuning is accomplished with 3-digit, front-panel push-button switch in 10 kHz increments.

The FM receiver, Model 887, is a high-performance, digitally tunable receiver, using a 4-digit front-panel push-button switch in 100 kHz increments.



## 1923AM Modulation Monitor

The 923 is NRSC compliant, features no overshoot linear phase filtering and internal modulation calibration for high accuracy. It has a 500kHz to 40MHz bandwidth and includes a PMDD circuit for digital peak accuracy. Optional frequency agile RF pre-selector covering 500kHz to 1990kHz allows off-air monitoring with the addition of an external antenna.

To assist with compliance, there are separate 2-digit LED displays on the front panels. They show the number of days, up to 12, since EBS test transmissions were last received and/or sent. On the 12th day, the display starts flashing. This assists in avoiding FCC citations for incorrect use or non-use of the EBS system.



### SC-100 RDS/RBDS Generator

The SC-100 generates RDS/RBDS signals through 100% Digital Signal Processing (DSP) subcarrier generation. While all static programming can be accomplished from the front panel with an easy to use menu system without a PC, the SC-100 is equipped with a remote RS232 interface for easy dynamic data input. The PC software program is included. Static data is stored in the unit in non-volatile memory. An internal real time clock is included for accuracy and the SC-100 is equipped with a large fluorescent back-lit LCD screen that is easy to read and program.

## MODULATION SCIENCES

### RDS-1 RDS Generator

Modulation Sciences has created a unique approach to generating RDS. MSI designed an RDS coder on a PC plug-in card for use with any IBM-compatible computer. This approach allows you to configure an RDS system with hardware tailored to your requirements using all off-the-shelf equipment. All operating instructions for the coder reside in the software, which makes it easy to implement changes or additions with a minimum of disruption. MSI supports both the American RBDS and European RDS standards.

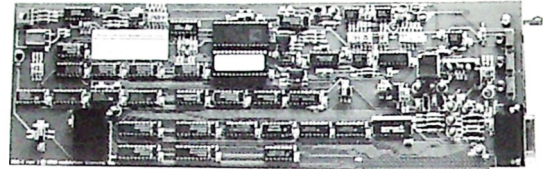

## RE AMERICA

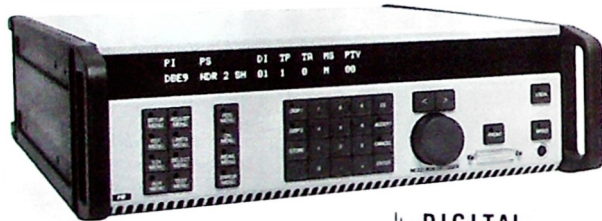

### RE 331 RDS/RBDS Decoder

The RE 331 is a modular decoder that monitors phase, level and frequency of all RDS/RBDS signals. It can provide a comparison between received information and stored reference information. Accuracy and long-term stability are ensured by means of a set of calibration procedures that run automatically. The decoder has a built-in help system and may also be controlled from a supplied PC program.



### RE 532 RDS/RBDS Encoder

The RE 532 represents the third generation encoder product for RE America and the most comprehensive encoding device that transmits all groups of data in the RDS/RBDS specification. Five data ports allow the broadcast of ancillary revenue producing services such as paging and Differential Global Positioning (DGPS). All data ports can be prioritized with inherent system security. The RE 532 can function as a stand-alone subcarrier generator and has 2 discrete pilot sync inputs for main and back-up transmitters. It can also be used as a composite loop-through and has power fail bypass. All RDS/RBDS data, records and signal parameters are defined by the supplied PC control program and stored in non-volatile memory.

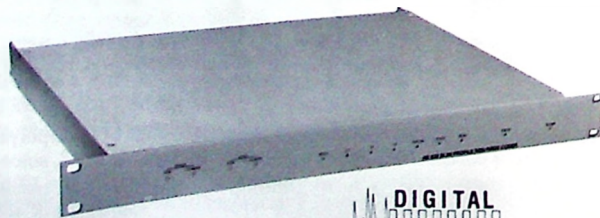

RE 533



### RE 533 RDS/RBDS Encoder

In a single rack space, the RE 533 encoder allows the FM broadcaster to become part of the RDS/RBDS system, letting you transmit your station call letters and format. The provided PC control software has a "Live Mode" that permits data entry (including radio text messages) to be done on-the-fly. Traffic and emergency alerts can be instantly sent and they will preempt cassettes or CD players on RDS/RBDS receivers. The RE 533 can operate as a stand-alone subcarrier generator or a loop-through, combining its 57kHz signal with your stereo composite before it goes to the exciter.



**MTR-15 Tape Recorder**

Otari's MTR-15 high performance 2 track mastering tape recorder offers Auto-Alignment™, a unique automatic record and reproduce alignment system for dramatically quick and easy set up of 4 speeds and 4 set-ups per speed. The MTR-15 is available as a ¼" half track, a ½" 2 track, and a ¼" half track with center track time code. Each is available as a rack-mount version with an optional roll-around stand (as shown). Features include a built-in 4 point autolocator, constant tension transport, 12.5" reel capacity, Dolby HX Pro headroom extension, built-in monitor speaker and more.



MTR-15N(¼")  
MTR-15H(½")  
MTR-15T(¼" w/time code)

**MX50IIN 2-Speed Tape Recorder**

The Otari MX50IIN is an economy version of Otari's popular MX5050 Series. The MX50IIN is available in 2-speed versions (3.75ips and 7.5ips, or 7.5ips and 15ips). Built-in mini autolocator with one Cue and return to zero function. Solid state switching. 8% vari speed. 10.5" reel capacity with independent reel size selection. Transformerless active balanced inputs on XLR ins and outs. Monitor speaker, headphone jack and volume control. Shown with optional 2B-51M floor stand.



MX50IIN  
2-Speed Tape Recorder



MX-5050 MKIV-2



MX-5050 MKIV-4



MX-5050 MKIV-8

**Mark IV Series Recorders**

Otari's Mark IV series is available as a ¼" 2-channel ½ track, ½" 4-channel, and ½" 8 track. All have built in mini auto-locator with three cue points, search zero and repeat functions. The transports are very smooth with microprocessor controlled logic, motion sensing and dynamic breaking. Standard features include a 37 pin

parallel I/O, ±20% speed control, active balanced inputs and outputs and reel size switches for both take-up and supply reels. The MKIV-4 and MKIV-8 now feature Gapless Seamless punch in and punch out. These two machines also include a rehearse mode. Your Harris Allied sales professional will help you choose the Mark IV best suited to your needs.

**MX-55NM Tape Recorder**

The Otari MX-55NM features a high quality production and mastering 2-channel half track tape machine. The 1.5" thick cast alloy deckplate and ½" thick cast alloy side panels provide maximum ruggedness. The MX-55NM is a 3-speed machine available in speed pairs from 3.75ips to 15ips (30ips optional). The MX-55NM's smooth transport is microprocessor based featuring dynamic breaking. Other features include ±20% speed control, 4 point auto-locator, easy access to card bay, Dolby HX Pro Headroom extension, gapless seamless punch in/punch out, cue



MX-55NM  
MX-55TM  
(w/time code)

speaker, 3 frequency test oscillator and more. Shown with optional 2B-51E floor stand.

**MX-5050 BIII Tape Recorder**

The MX-5050 BIII is the latest in a series of successful 2-channel professional tape recorders. The BIII features a built-in miniauto-locator with 3 one-touch cue point memories, search zero and repeat functions. The transport features positive action control with microprocessor governed logic, motion sensing and dynamic breaking. The variable speed control has a range of ±30%. The BIII is easy to interface to the outside world via our standard 37 pin parallel I/O accessing 9600 Hz DC servo capstan control. All inputs and outputs are transformerless active balanced.



MX-5050 BIII

## TASCAM

### 22-2 Tape Recorder

The Tascam 22-2 is the basic half-track recorder/reproducer with independent record mode selector and 1 tape/source monitor for each channel. Independent mic/line mixing and output level control for each channel. Remote pause function for record and play. 7½-15 ips speeds.

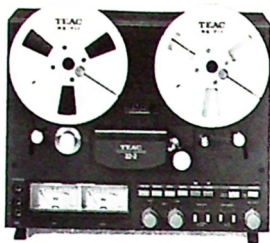

### 32 Tape Recorder

Tascam's 32 is a half-track ¼" master recorder/reproducer with 10½" reel capacity, 15 and 7½" ips speeds, independent L&R record mode, simul-sync, full frequency response in sync mode, function and output select and punch in/out recording. The 32 also features ±12% pitch control, dump edit, mic inputs, independent input/output level controls, headphone jack with volume control, cue control, FL tape counter and zero return.



*Harris Allied also sells the Tascam multi-track recorders.*

### 34B Tape Recorder

The Tascam 34B is a 4-track ¼" recorder/reproducer with 15 & 7½ ips speeds, 10½" reel capacity, full frequency response in sync mode, function and output select and punch in/out recording. The 34 also features ±12% pitch control, dump edit, cue control, FL tape counter and zero return.



### BR20 Tape Recorder

The BR Series (Broadcast Recorder) is Tascam's professional 2-track recorders. Loaded with valuable features, the +4dBm XLR balanced BR-20 half-track, equipped with built-in rack-mounts, has a highly functional shuttle control by using a combination of EDIT and FFWD/REW ("Quick Cue") that provides for smooth, accurate cue and review. NAB/IEC equalization 250/320 operating levels can be adjusted from the front panel via convenient switches while a self-contained speaker allows for monitoring of production material. The **BR-20T** is a ¼" half-track with center track time code and gapless/seamless punch in/out.



## A-LINE

### A-Line Side Panels

The Otari 5050 BII and BIII handle much easier when angled toward the operator. This is easily and economically accomplished with A-Line side panels. Simply remove the side panels which come with your 5050 BII/BIII, use the same screws, and attach the A-Line side panels.

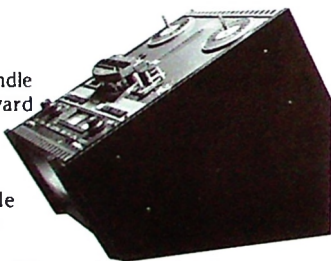

### Reel Storage

Every station has a room *running-over* with reel-to-reel tapes, commercials, programs and a wide assortment of other types of taped material. The A-Line reel tape storage cabinets are available in standard or custom sizes for every application.

Model	Tape Size	Cap	Shipping Weight
A/L 350TB	7"	350	175 lbs.
A/L 500TB	7"	500	225 lbs.
A/L 175TC	10½"	175	200 lbs.
A/L 250TC	10½"	250	250 lbs.

*Certain products not available in some areas.*

## AMPEX

### Ampex Tapes

Harris Allied can supply all your Ampex tape needs. Call for quotes for *any* requirement of tape such as the 456 pictured and the 472 Studio Audio Cassettes. Improved engineering gives the 472 cassettes long-lasting superior performance, maximum dynamic range, cleaning leader tape with both normal Bias Type I and High Bias Type II. Quantity discounts available.



## 3-M



### 3M Tapes

3M 806 audio maturing tape is specially formulated to meet high output/low print requirements. This flexibility is further enhanced by its degree of interchangeability with 3M 226 and 808 audio tape. Call us for all your 3M tape needs.

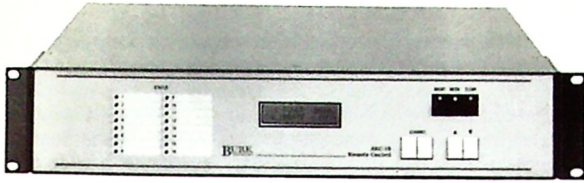

### ARC-16 Remote Control

The ARC-16 includes 16 analog metering channels, 16 status channels and 32 command outputs (16 raise & 16 lower). The single unit configuration includes the transmitter unit with front panel 32 character digital display and the new Enhanced Speech Interface (ESI). This allows full remote control from any Touch-Tone® telephone. With a Studio Controller, the system has a constant link with the transmitter for instant response to any problem and you can still have access via telephone. The ARC-16 can be configured to control up to three separate transmitter locations, or a single transmitter from up to three studio units. The **AutoPilot™** software allows for fully automatic control. With modes defined by the user, the program will take corrective action when needed.



### TC-8 Remote Control

The TC-8 is a full-time economical dual unit remote control that provides simple operation, an easy-to-read dot matrix display and one-person push-button calibration. Calibrations are retained in non-volatile memory for orderly recovery from power outages. It has 8 analog metering channels, 8 status channels and 16 control outputs (8 raise and 8 lower) plus a fail-safe output to assure positive control. The two units can be linked by dedicated lines, STL subcarriers, 450 MHz TRL or digital links. The required subcarrier generators are built-in at no additional cost. You must provide an SCA receiver to recover telemetry. The optional IP-8 interface panel provides 10-amp relays with normally open and normally closed contacts, brought to a barrier strip.

## FFI

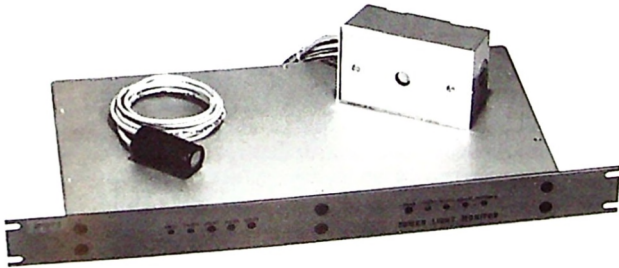

### Tower Light Monitor

The Tower Light Monitor measures the current flow through the electrical conductor that supplies the tower lights and provides immediate notification of any bulb in the system. A memory alarm notifies the daytime operator of a failure the previous night and the unit is directly compatible with most remote controls. Either rack mount or wall mount is available.

## GENTNER

### VRC-2000 Voice Remote Control

The VRC-2000 Voice Remote Control from Gentner allows you the freedom of transmitter remote control from anywhere. You communicate with the VRC-2000 via telephone, modem, two-way radio or bi-directional audio link; the VRC-2000 responds with synthesized voice or data. With 16 metering inputs, 16 status inputs, 32 command outputs (configured in 16 channels), automatic & time of day functions and automatic alarm reporting and correction, the VRC-2000 is a complete solution for your remote control needs.

The VRC-2000 now includes the Data Interface in the basic system price. Also included: SETUP VRC software and a telephone surge protector.



A VRC-2000 package is available from Gentner, including the VRC-2000, Command Relay Unit and two Screw Barrier Strip panels

## HARRIS

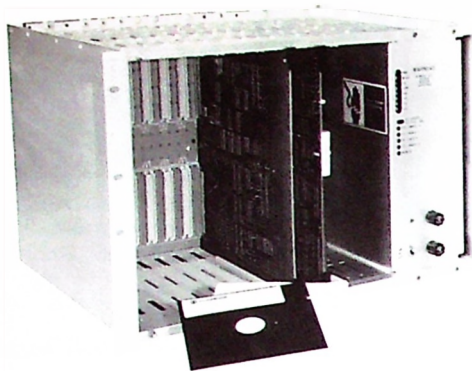
**DC-128 Remote Control System**

The DC-128 is an intelligent remote control system that is expandable from 16 to 128 control outputs, status inputs and analog channels. It is a PC-based system that allows connection of up to 3 personal computers directly or through modems. Pull-down menus ensure easy programming from the PC keyboard. The system provides a full range of automatic functions that allow a wide range of flexibility.

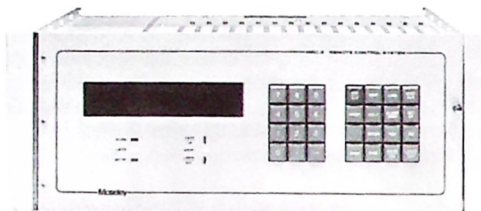

## MOSELEY

**MRC-2 Remote Control**

The Moseley MRC-2 is a true building block system. The basic system consists of one Control Terminal with Data Acquisition/Command Unit. Additional Remote and Control Terminals may be added at other locations.

At a given site as many as 256 command lines, status inputs and telemetry inputs may be handled. Operator control can be from a Control Terminal or a PC with the optional emulation software. This adds both feedback oriented and time oriented functions to the system. The PC Control Option is capable of multiple steps with logic branching at many levels to accommodate control and switching of multiple transmitters, antennas and other equipment.

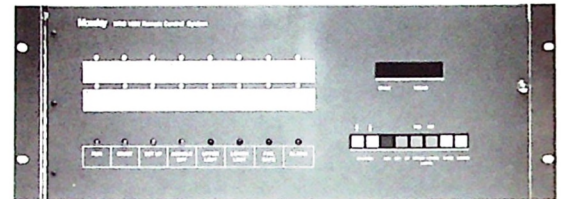
**MRC-1620 Remote Control**

The MRC 1620 system consists of a Remote Terminal that can operate with either an optional Control Terminal or IBM compatible PC with TaskMaster20 software, to monitor and control a remote facility from both dedicated and/or dial-up control points. The MRC 1620 Remote Terminal from Moseley comes equipped with 32 relay isolated command outputs (16 raise & 16 lower), 16 TTL status inputs and 16 analog metering inputs (with limit checking) with the required terminal connectors. The **TaskMaster20** software has pull down menus to assist with the operation of the system. The monitor screen views the parameters for all 16 status and telemetry channels. During alarm conditions, intelligent, automatic corrective action can be taken by the Remote Terminal under the direction of the TaskMaster20.

***Harris Allied works for you!***  
***Call us for all your broadcast equipment needs.***  
***In the USA 800-622-0022***  
***See Pages B & C for Worldwide Contact Information.***



**AR-10 Mobile-Relay RPU Receiver**

The Marti AR-10 Series Receiver is a portable or mobile repeat receiver. This receiver has a built-in AC power supply, and will operate from an external source of 12-15 volts DC. A built-in sub-audible tone decoder meets FCC rule 74.431 allowing this receiver to automatically turn on a mobile transmitter upon receiving an encoded signal from a hand-carried portable transmitter, thus automatically relaying a broadcast to the base station receiver over a greater distance. Available as a dual frequency unit, the AR-10 also includes a monitor speaker and terminals for feeding telephone lines in portable operations.



**CR-10 RPU Base Station Receiver**

Model CR-10 is a rack-mounted VHF or UHF base station receiver designed for broadcast remote pickup service. This receiver has dual frequency capability built-in. Marti technology has provided the highest frequency response with the lowest noise and distortion possible for the assigned channel bandwidth. The CR-10 features a built-in test meter, squelch relay, built-in sub-audible tone decoder, monitor speaker, special noise reduction circuit, 90dB spurious rejection. 3½"Hx19"Wx12"D. Available in single, dual or four frequency versions.



**RPT-2 Hand-Carried Transmitter**

The RPT-2 is a hand-carried broadcast quality continuous duty transmitter. It will operate from its internal ni-cad battery, from 115 VAC power or from external 12 VDC power. A special sub-audible encoder enables the RPT-2 to access Marti mobile repeaters for coverage of indoor events. 3¾"Hx8¾"Wx11"D. Unit weight: 7 lbs.



**RPT-15 Portable/Mobile Transmitter**

The Model RPT-15 is a compact 15 watt transmitter designed for portable or mobile remote broadcast service. It delivers the maximum power allowed by the Commission for airborne remotes such as traffic reports. The RPT-15 has a built in power supply for operation on 115 VAC. It will also operate on an external 12-14 VDC supply. Standard features include dual frequency and subaudible encoder for use with Marti automatic repeaters. All this plus famous Marti broadcast quality and continuous duty operation. 3¾"Hx8¾"Wx12½"D. Unit weight: 10 lbs.

Harris Allied can supply all the pieces needed for a complete RPU system, including antennas, transmission line, cavities, etc. Please call for more details.

**RPT-30 Remote Pick-Up Transmitter**

RPT-30 featuring 45 watts at 140-180 MHz and 30 watts at 400-480 MHz is today's hottest selling RPU product. Single and dual frequency models available. 100% duty cycle with 4 inputs (all mic level or 3 mic/1 line). FM-quality limiter included. 120VAC and 12VDC supplies included. 3½"Hx11½"Wx13½"D. Unit weight: 13 lbs.



RPT-30

**MCS-800 Audio Companding System**

MCS-800 is a Marti factory installed option that is available for RPT-30, RPT-15 and RPT-2 transmitters and CR-10 and AR-10 receivers. It is a 2:1 companding system that reduces noise and raises effective power.

MOSELEY

**RPL 4000 Remote Programming Link**

The RPL-4010 transmitter is frequency synthesized in the UHF RPU band. Internal DIP switches set the operating frequencies(s) and you can also program the FM deviation. There is a built-in 400 Hz test tone for path alignment and 100% modulation calibration. A high performance 2:1 noise reduction circuit extends usable path distances. The transmitter also provides a three mic/line mixer and a 27 Hz tone encoder for repeater keying. Like the transmitter, the RPL-4020 receiver features comprehensive metering, remote control operation and rugged switching power supplies.



TFT



**UHF RPU System**

The TFT RPU system offers frequency agility, selectable FM deviation, and receiver bandwidth, front panel diagnostics metering and DTMF control. The 8888 transmitter produces 20 watts and has a three mic/line input mixer along with a headphone output. The 8889 is a microprocessor-controlled triple conversion receiver and can also function as a repeater receiver with the added security of DTMF signaling.

WILL•BURT

**Hurry-Up Mast**

The 25-foot Hurry-Up Telescoping Mast is designed for fast, easy deployment of lightweight antennas. This portable 20 lb. telescoping mast is ideal for elevating equipment such as small ENG microwave antennas and RPU antennas.

The Hurry-Up consists of 6 graduated aluminum tubes which nest one inside another. The mast is extended manually by pushing up the sections and fixing them in position using quick lock/release collars. It can be extended to its 25 foot height in one minute or less even when wearing thick gloves. The Hurry-Up mast design allows for quick direction adjustment with rigid azimuth locking. When supporting a 2 square foot topload, this mast has a survival wind speed capacity of 54 mph when fully extended and deflects less than 2 feet in 35 mph winds.

Hurry-Up is free-standing (without guylines) in its universal vehicle mounting stand. This vehicle stand is a "drive-on" aluminum plate with an attached reinforced holding tube into which the telescoping mast is lowered and locked in position. The vehicle mounting stand can also be used with an optional 2 level guy kit if the mast is to be field mounted



away from the vehicle. For permanent vehicle mountings, external support brackets are available. Harris Allied handles the complete Wil•Burt line, including the Standard and Heavy-Duty Pneumatic masts and transport trailers. Please contact us for more details.

ANJ

**ANJ Mast**

The ANJ mast mount is constructed of heavy-gauge steel. Knock down for transport. Easy and quick assembly. Simply add mast, antenna, coax and roll the vehicle of your choice onto the steady plate.

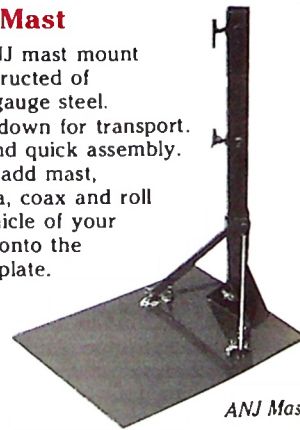

**We Buy, Sell & Trade Selected Used Radio Equipment.**

**Turn old, used equipment into "CASH" on your next transaction with Harris Allied! Call or Fax today!**

## ANDREW

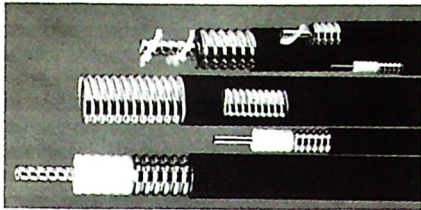

Andrew's low-loss HELIAX foam-dielectric and air-dielectric cables provide an efficient connection between the satellite antenna and satellite electronics. Popular sizes for satellite applications include  $\frac{1}{4}$ "",  $\frac{3}{8}$ "",  $\frac{1}{2}$ " and  $\frac{7}{8}$ ". Larger sizes are available for other broadcast applications, contact Harris Allied for assistance. Andrew elliptical waveguide is the optimum choice for most satellite transmit applications. Andrew quality line, connectors and accessories are available at Harris Allied.

## CABLEWAVE

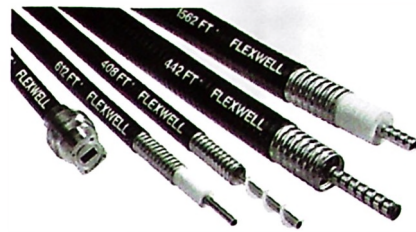

Cablewave Systems low loss foam flexwell coaxial cables are proprietary designed, featuring a closed cell foam dielectric with low density and high velocity specification. These cables provide low loss performance characteristics that are almost as low as air dielectric cables but with none of the pressurization requirements of air cable. Cables are supplied with a black polyethylene jacket for direct burial applications. Available in  $\frac{1}{2}$ " and  $\frac{7}{8}$ " for satellite, other sizes for broadcast. All available at Harris Allied.

## CALIFORNIA AMPLIFIER

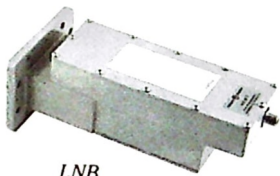

LNB

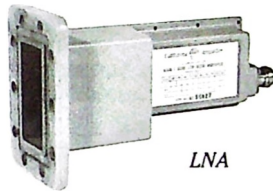

LNA

### Active Power Divider

The Active Power Divider (not pictured) from California Amplifier makes multiple-receiver hookups simple and cost effective. Simply connect your LNA to the active divider, and the divider to any down converters that provide DC power thru the cable. You are now connected! DC isolation between ports while permitting either receiver to power the LNA. A perfect solution to adding receivers to your existing satellite system. Ask Harris Allied for the HOS-LPD.

### LNB

The highest performing LNBs are from California Amplifier. For broadcast applications the HEMT commercial LNB offers additional gain and low noise performance. This higher gain helps keep your reception solid, and California Amplifier's excellent reliability provides performance broadcasters demand.

### LNA

California Amplifier has been providing rugged LNAs for many years. Currently standard high gain and low noise specifications, assure you of a quality product. Reliable, long life proven by the many in use by broadcasters indicate the California Amplifier LNA should be your first choice. In stock now at Harris Allied.

## COLORADO MAGNETICS



### Sat Cue 500

Colorado Magnetics Sat Cue 500 was designed to allow radio stations to tailor their walk-away time to suit their needs. Up to 15 stop-sets can be programmed on a take or skip fashion. In addition a second set of 15 programmed breaks can be set up in a day/nite or heavy/light spot load routine to accommodate format clock variations. Interfacing to studio equipment is via relay to assure compatibility. The network cue provides the switch cue, while the return cue can originate from the network or the local commercial machine. The best in flexibility from the company with satellite solutions, Colorado Magnetics.



### Sat Cue 400 Switcher

Colorado Magnetics Sat Cue 400 is an audio switching unit designed to be used with satellite radio program networks. Activation is provided at the proper times by the satellite network cue system, both to lease the network for local commercial insert and again to re-join the network. A second network input is provided for the optional news network.

## Leasing Satellite Equipment from HARRIS ALLIED

- Means convenience
- Conserves capital
- Protects from obsolescence
- Allows you to pay as you go
- Provides tax advantages
- Offers better terms
- Permits Alternative Minimum Tax (AMT)
- Leaves bank lines untouched
- Helps overcome budget limitations
- Allows more liberal credit criteria

Talk to us about leasing. We'll explain how a lease can work for you!

317-962-8596

Certain products not available in some areas.

HARRIS ALLIED



### 3.5 Meter Ku-Band Antenna

The 3.5M was specially designed for transmit and receive applications of Ku band is microprocessor controlled and fully automatic. It features cassegrain feed, parabolic accuracy with full arc coverage. Has a transportable version and also available in E over Z configuration or as a dual axis motorized version. Easy assembly without special tools or crane.



### 5.0 Meter Antenna

The 5.0M is the choice for professional reception of video for television broadcast, or where additional antenna gain is required for low-powered audio network reception. Rugged, three-piece fiberglass construction maintains extremely good surface tolerance for maximum gain and minimum sidelobe performance. Rated gain of 44.9 dB.



### 2.4 Meter Ku VSAT Antenna

The 2.4M is a three-piece fiberglass parabolic with full offset, prime focus. Power handling is 750 watts, CW, max with a receiver operating frequency of 11.7-12.2 GHz (Transmit frequency of 14.0-14.5 GHz) and single or dual linear polarization. Sidelobe envelope per FCC 25.209.

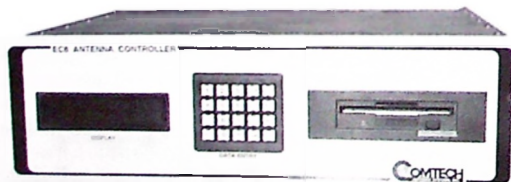

### EC8 Antenna Controller

The new EC8 satellite antenna controller is user-friendly. Antenna can be moved under direct control from the keypad, or moved to any desired satellite by entering its orbital longitude. Likewise any antenna position — up to 500, can be stored for later recall safe from power failure. Large 32 — character illuminator display of current position number prompts user. Also controllable from IBM-compatible PC or EIA-232, phone line or dial-up line.

**Note: EC6 also available.**

### 3.8 Meter Antenna

The 3.8M is the perfect antenna for reception of any format audio network, whether the transmission is Digital, Subcarrier, or SCPC. Careful, tight tolerance construction assures maximum gain and minimum beamwidth so necessary for today's crowded satellite arc. Range tested gain spec of 42.9 dB!



### "OFFSAT" Antenna

Here's a unique one-piece antenna design with an innovative offset feed that makes the "OFFSAT" the *only* antenna in its size category capable of *exceeding all FCC specifications for 2 degree spacing*. Comtech's "OFFSAT" is the intelligent response to the new, stricter requirements and it has the surface tolerance necessary for Ku-band. As with all Comtech antennas, the "OFFSAT" is precision-made of fiberglass and is available for uplink and downlink applications in AZ/EL, Polar or Transportable configurations, both C-band and Ku-band.



### 2.5 Meter C Band Antenna

The 2.5M gives you the ultimate in savings, flexibility and convenience in a 250 lb. unit. It is easily installed, lightweight and employs a powerful offset feed system conforming with all FCC requirements. The 3 piece composite reflector is manufactured whole, then precision-cut for low cost shipping and trouble-free assembly.

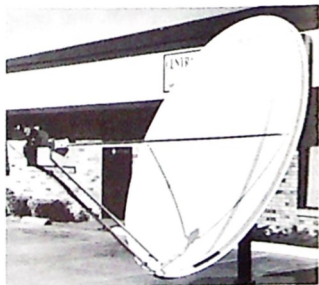

### 1.8 Meter Flyaway Antenna



The 1.8 meter flyaway is a totally new concept in KU-Band flyaway antennas for quick satellite communication response. The 1.8 Meter Fly-Away antenna is aircraft baggage shippable, and has a total packed weight of 330 lbs. Packed in three cases, the mount case doubles as a wheeled carrier for the two reflector cases. One person can maneuver the entire unit through airports with ease!



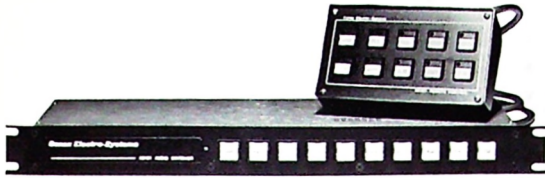

**AS-101 Switcher**

The Conex AS-101 Audio Switcher allows any one of ten stereo sources to be switched to the stereo output buss. Switching is accomplished by pressing one of the illuminated buttons on the front panel or via the remote connector on the rear panel. Features include two switching modes (immediate and overlap). Individual audio level controls, transformerless inputs and output, 600 ohm or 10K bridging.



**CG-25(R) Tone Generator**

The Conex CG-25(R) Tone Generator provides a simple, low-cost method of encoding reel tapes for automation/unattended playback. It provides adjustable pre-roll and stop timing as well as tone timing to keep your format execution consistent. Harris Allied can provide table-top or rack mount versions.



**CS-25 Tone Sensor**

The Conex CS-25 is a dual bridging type 25 Hz tone sensor for reel tape machine control in broadcast automation and tape control systems. It features "dry" contact closure for duration of sensed tone as well as momentary pulse at end of tone, and adjustable delay stop for total compatibility. The front panel has indicator lights (one per channel) to show presence of tone. A front panel inhibit switch allows convenient bypass of control when desired.



**UM-33 Line Amplifier**

The Conex UM-33 is a stereo, eight channel in, two channel out general purpose cue, monitor, and line amplifier. Features include: 88 balanced bridging stereo inputs, stereo VU meters, stereo monitor amp, speakers and more, all in a 1-rack-unit-high package.

If you did not find the satellite equipment listed herein that you are seeking — please call the Harris Allied satellite experts and allow them to resolve your search.



**ADH-2 Dehydrator**

The ADH-2 is a rack mountable (optional weather proof box) automatic dehydrator for the pressurization of waveguide, feed horns, and air-dielectric coaxial cable. Standard pressure is a precise 0.5 PSI for the protection of waveguide windows. Quiet operation, low vibration level, low heat, digital display and malfunction alarm come together to make the Environmental Technology ADH-2 a must at up link sites. Contact Harris Allied for all the details.



**LCD-3 Sensor**

The LCD-3 is an inexpensive way to control snow and ice melting equipment. Intended for smaller satellite antennas with heaters, the LCD-3 operates only between 17 and 38 degrees F. during precipitation and for one hour thereafter. Environmental Technology has a complete line of snow, ice, and rain sensors with various options to solve your problems. For information contact Harris Allied.

HARRIS ALLIED

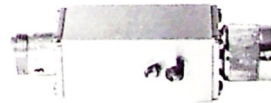

**Power Inserter/D.C. Block**

The Allied Power Inserter/D.C. Block is used as a power inserter for supplying external bias to an LNA independently of the satellite receiver.



**Power Divider/Splitter**

The Allied PD-2 series of Power Dividers/Splitters are employed to two-way split an RF input signal in the 3.7-4.2 GHz (C-band) satellite band.

## HENRY ENGINEERING



### Net Commander Switcher

Air satellite formats without automation! Henry Engineering's Net Commander is an economical method to switch audio during satellite programming. Designed for formats with up to 5 stop-sets per hour, the net commander will break away from the network audio to run commercials or other local material. The net commander allows you to select 1 to 5 stop-sets per hour before repeating the format, allowing walk away time for other station duties. Simple to program, reliable performance and economical price, as expected from Henry Engineering.

## MUELLER

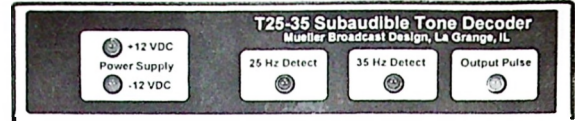

### T25-35A Tone Decoder

Automate your satellite-delivered programming with a Subaudible Tone Decoder. The T25-35A includes the subaudible tone detector, power supply and decoding circuits in an aluminum enclosure. It operates from 120 volts AC and is entirely self-contained. It works with any network using 25 and 35 Hz tones for cue signals.

The T25-35A will detect both 25 and 35 Hz subaudible tones and provides a 250 millisecond pulse via normally-open relay contacts for the three possible tone combinations: 25 Hz alone, 35 Hz alone, and 25 & 35 Hz together. These signals are delayed for about 300 milliseconds, at which time they are latched and output.

## NORSAT

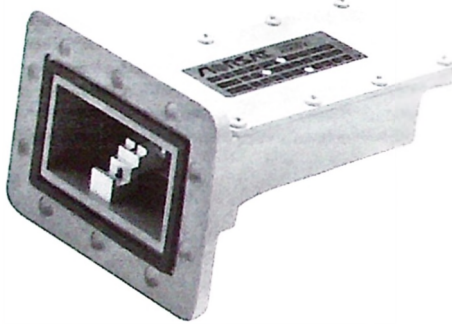

### 8100 LNB

Norsat's 8100 and 8200 Series C Band LNB's incorporate the latest HEMT technology to provide industry-leading performance. Improved video, audio and data performance, are achieved by higher gain, lower VSWR and extremely stable LO performance in a compact 15 oz. weatherproof case with field proven reliability. The 8100 has  $\pm 100$ kHz LO stability (GHz) and an industry-leading warranty of 2 years.

### 8200 LNB

The Norsat 8200 has all the features above, but with  $\pm 250$ kHz LO stability (GHz).

## STANDARD COMMUNICATIONS



### MT-830 Receiver

The standard agile Omni Broadcast model MT-830 is a television rebroadcast quality satellite receiver offering RS250B (satellite) proof of performance with the broadcast package option. The ease of use, flexibility and vast array of options make the Omni Broadcast the most advanced satellite receiver in the commercial TVRO market. Features include: C/Ku selection, IF bandwidth select, synthesized tuning, two audio agile sub-carriers, computer remote control, and many additional features and accessories. Contact Harris Allied for the complete specs.

#### Packages:

- MT830 Agile Omni** C & Ku-Band 950-1450 LNB input RS250C broadcast certified, video receiver with one audio, two antenna inputs & 36 MHz BW. Programmed for all satellites in ITU Region 2.
- MT830B-PKG** Broadcast Package with the following options: CMF70, 2-CRL810s, MIFCK, CAD800C & CAD800B.
- MT830C-PKG** Broadcast Remote Control Package with the above options plus CRC850 remote control board.
- MT830BR-PKG** Broadcast Remote Control Package with the following options: CMF70, 2-CRL810s, MIFCK, 2-CAD800C's, & CAM830.



### Intercontinental Receiver

Never before has one receiver worked so well from INTELSAT to all DOMSAT formats in C, Ku and S-band frequencies.

The Intercontinental features six I.F. band pass filters, from 36 MHz to 16 MHz, five audio filter selections from 880 to 75kHz, and six audio de-emphasis circuits, with a universal power supply built for rigorous 24-hour-a-day operation.

#### Code Definitions in Packages:

- CMF70** Multiple IF Bandpass Filter Module
- CRL810** P and B Dual Polarization RF Relays
- CAD800C** Audio Subcarrier Demodulator
- CAD800B** Audio Subcarrier Demodulator
- CRC850** Remote Control
- MIFCK** Microwave Interference Filter Wiring Kit
- CAM830** Control Access Module

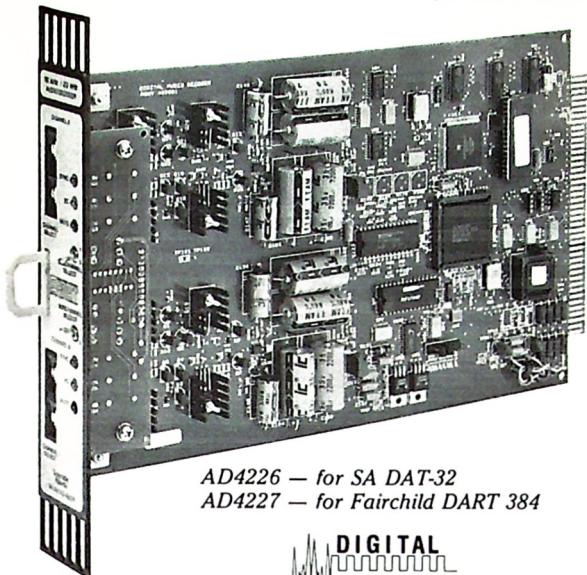

AD4226 — for SA DAT-32  
AD4227 — for Fairchild DART 384



**SEDAT™ Dual Channel 10/20 kHz**

Digital audio decoders use Scientific-Atlanta's proprietary SEDAT digital audio compression technology for increased bandwidth and audio quality at one third the bit rate of the previous DATS system. The dual channel decoders allow reception of one stereo or two monaural channels when combined with a DAT-32 satellite receiving system or its equivalent. The 10/20 kHz selection feature allows for the reception of either 10 kHz audio at 64 kbps or 20 kHz audio at 128 kbps.

For seamless migration to SEDAT technology, the decoder modules provide plug-in compatibility with the Scientific-Atlanta Model 7325 Digital Processing Unit and the Fairchild DART384 satellite receiver. Each unit is configured for operation in compressed (SEDAT) and uncompressed (DAT) satellite signal transmission modes.

SEDAT Algorithm Family		
	Bandwidth	Data Rate
SEDAT I	20 kHz Monaural	112 kbps - 128 kbps
SEDAT II	20 kHz Joint Stereo	192 kbps
SEDAT III	10 kHz Monaural	56 kbps - 64 kbps
SEDAT IV	20 kHz Joint Stereo	112 kbps - 128 kbps
SEDAT V	7.5 kHz	32 kbps

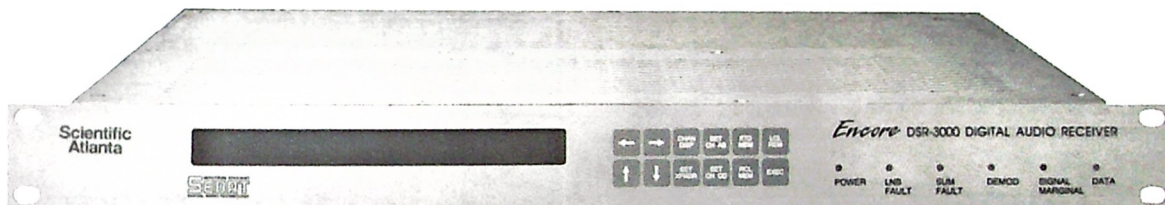

**Encore DSR-3610  
Digital Satellite Receiver**

Scientific-Atlanta has long been recognized as the world leader in satellite audio technology. Scientific-Atlanta invented digital audio satellite transmission and reception more than a year before compact disc technology was introduced.

Continuing this tradition of pioneering digital audio technology, the Encore DSR-3610 Digital Satellite Receiver represents a major achievement in satellite communications technology.

Scientific-Atlanta has developed a single satellite receiver that can be configured to meet the vast requirements of the nation's broadcasters. The Encore DSR-3610 is a member of the DSR-3000 Series of Digital Satellite Receivers and supports every major U.S. digital radio network.

When combined with the SEDAT Studio Server and other Scientific-Atlanta uplink and downlink equipment, the Encore DSR-3610 can become an integral part of any radio network's distribution system, large or small.

**Features:**

- Full transponder format
- Compatible with DATS format & the SEDAT Algorithm Family
- DATS voice cue optional
- Transponder and channel agility
- Remote control port
- Addressability and authorization control available
- L-band input accepts signal from either stabilized or lower cost nonstabilized C-or K-band block downconverter
- 1.75-in. high chassis preserves equipment rack space
- SEDAT-OSI compressed digital audio interface
- AES/EBU non-compressed digital audio interface
- Printer/text port
- Network data protocols for text and network control optional
- 16 opto-isolated open collector closures, relays optional
- BPSK modulation with FEC performance superior to previous models
- Front panel display and control via two-line LCD display and push-button keys
- Front panel headphone monitor jack and selector switch

Satellite

Certain products not available in some areas.

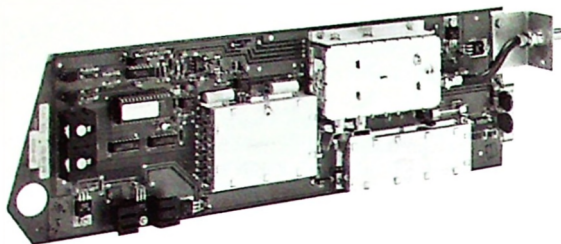

### Model AD7007 Downconverter

The Model AD7007 frequency synthesized agile L-band-to-IF downconverter for C-band or Ku-band single-channel-per-carrier applications is a modular plug-in unit. The Model AD7007 Downconverter plugs into a Scientific-Atlanta Model AD7550 Receiver or compatible satellite receivers, as well as the Model AD7350 Transmitter/Receiver Processor.

The downconverter is compatible with the Scientific-Atlanta Model AD6305 and the Model AD6303 Low Noise Block Converters and are tuneable across the entire 950MHz to 1450MHz range. It has on-card diagnostics and thumbwheel tuning.

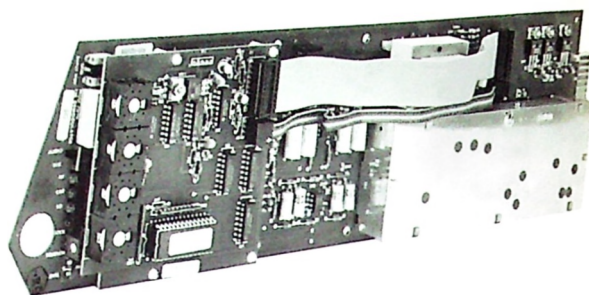

### Model AD7010 Demodulator

The Model AD7010 Satellite Analog Audio FM Demodulator is a popular high-quality, frequency-agile synthesized demodulator suitable for single-channel-per-carrier satellite networks programming analog audio or paging services. It is modular and totally compatible with Scientific-Atlanta's Model AD7550 Receiver and the Model AD7350 Satellite Transmitter/Receiver Processor as well as other popular satellite receivers. Tuning within the 70MHz satellite satellite IF band is frequency synthesized, eliminating crystal changing or factory retuning and providing a single card for most network services. Tuning methods include standard DIP switch, code plugs or optional thumbwheel controller.

Other features include selectable deemphasis, on-card or external filtering, a standard high performance 2:1 expander (with options for 3:1 or others) and a high level audio output transformer which provides the best possible isolation while maintaining flat frequency response and low distortion.

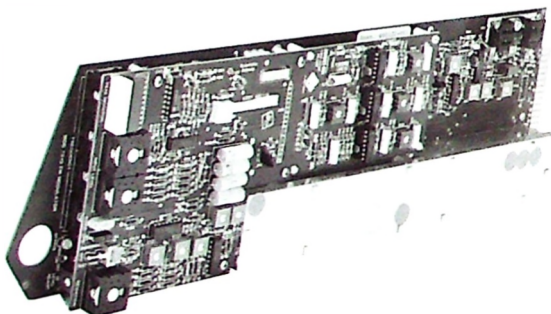

### Model AD7310 Modulator

The Model AD7310 Analog SCPC FM Modulator is a full featured, frequency synthesized modulator ideal for high-quality analog audio single-channel-per-carrier network applications. It will accept 50Hz to 15kHz audio and produce a modulated output in the 52MHz to 88MHz range for processing at the uplink. It is also capable of summing FSK data subcarrier channels with the main program audio. Features include 2:1 companding (3:1 optional), switchable pre-emphasis, and thumbwheel output frequency selection in 25kHz increments. It has an easy-to-use bar graph meter for frequency deviation adjustment, a built-in 400Hz tone generator, and an on-board dispersal oscillator. The input level attenuator is also thumbwheel controlled.

The Model AD7310 Modulator plugs directly into a Model AD7350 Transmitter/Receiver Processor. It can be configured for automatic switching to a back-up module in redundant installations.

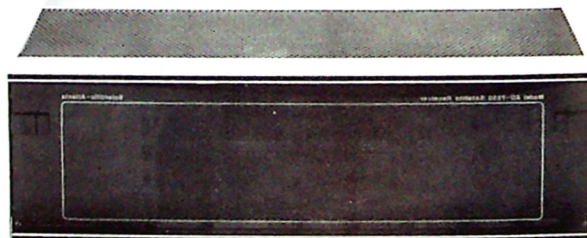

### Model AD7550 Satellite Receiver

The Model AD7550 Satellite Receiver is the first single-channel-per-carrier receiver to offer C-band or Ku-band reception of high-quality program audio, for radio broadcasters, sports networks and news networks. The Model AD7550 Receiver has modular plug-in slots which can be configured for reception of six simultaneous channels with options for audio program channels, digital channels, cue decoding and addressable message selection. Each demodulator is frequency agile with DIP switch or optional thumbwheel channel selection and provides front-panel status, level and fault indicators for easy operation and troubleshooting.

The cue decoder option provides for remote control of up to 12 station functions and a message printer output. The addressable digital processing unit option selects messages from the data stream and provides ASCII output to an RS-232.

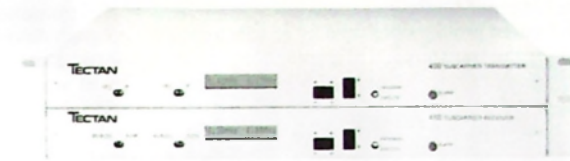

## 450 FM Subcarrier

The Tectan 450 is a frequency agile, synthesized FM subcarrier designed specifically for narrow band multi-channel applications. Each unit (1 rack unit high) contains two completely independent transmitters or receivers for stereo applications over terrestrial microwave, satellite or analog fiberoptic facilities. The superior audio performance is due in part to the noise reduction system developed from the Tectan 3:1 compandor presently in use worldwide for satellite SCPC channels. Exceedingly high quality audio in a limited baseband spectrum. Call Harris Allied for your audio solutions.



## 454 FM Subcarrier

The Tectan 454 is a frequency agile, synthesized FM subcarrier designed for satellite audio reception with ultra low distortion. Both channels are digitally synthesized and frequency agile from 1 MHz to 9.99 MHz compatible with most non-companded subcarrier audio channels. To get the best audio recovery from your video receiver add the Tectan 454.

# WEGENER



## Series DR180 Digital Receiver

Subcarrier the Digital way! Wegener's Digital Audio Subcarrier Receiver family provides high quality audio in all of the popular configurations via the MPEG compression algorithm. The DR series has models compatible with FM\* subcarrier or subcarrier above video transmission formats.

The receiver accepts an L-band input and supplies power for an LNB. Transponder and subcarrier frequencies are selected via on-board DIP switches or Wegener's ANCS control system in addressable receivers. Both in-band and out-of-band data printer and control is possible. The robust QPSK is demodulated, rate 3/4 Forward Error Corrected, and passed to the World standard MPEG digital audio decoder. For any given data rate, the MPEG decoder automatically switches between mono or stereo to track the mode of the originating encoder.

Options include tuning, audio fade, mute or boost and a host of other options are available to serve your needs. For the complete line of WEGENER products contact the stocking distributor, Harris Allied!

## 412 FM Receiver

Tectan's 412 is a frequency agile, single-channel-per-carrier (SCPC) wideband FM receiver for satellite transmission and reception of high quality audio, voice or data. The standard mainframe accepts up to four modulators or demodulators or any combination of either. Demodulators are available in two models. The 412-basic is PROM driven for NPR network reception. The 412-360 is agile thru 360 standard channels. Both the mods and demods are available in wide (15kHz) or narrow (7.5 kHz) or switchable. Tectan mods and demods are rated tops in audio performance and reliability.

## 455 Subcarrier

The Tectan 455 composite subcarrier system is engineered to provide a transparent path for the complete MTS/BTSC composite signal over any video microwave system. Extremely low distortion, flat frequency response and outstanding long-term stability, the 455 has almost no measurable effect on stereo audio performance. Now television can enjoy the benefits of composite audio via the existing video link. Contact Harris Allied for full details.

## Series 1800 Receiver

The Series 1800 Stereo Radio Network Receiver is a commercial C/Ku band satellite receiver that is designed for use in stereo radio networks using either FM2 subcarrier or video subcarrier transmission technology. It accepts the L-band output from an LNB and features synthesized, dip switch controlled transponder and subcarrier control of automated commercial insertion equipment. Equipped with two synthesized audio demodulators which can be tuned to subcarriers from 0.15 to 8.2 MHz, the Series 1800 Stereo Radio Network Receiver produces two 15 kHz audio channels. Audio muting upon loss of signal with front panel indication is a standard feature. The outputs of the audio demodulators are routed through sub-audible cue tone decoders where the cue tones are filtered and corresponding outputs are sent to a six or fifteen function relay interface panel mounted on the rear panel of the receiver. 500 Hz high-pass filters remove the cue tones from the audio. The audio is presented as 600 ohm balanced audio at the rear panel.

**Series 1600 Audio & Data Transmission**

The Wegener Communications, Inc. Series 1600 Audio Transmission System provides high quality 15 kHz bandwidth program channels for the transmission of stereophonic or monaural audio channels above video in satellite distribution networks as well as microwave channels. Stereo channels are transmitted as separate left and right channels using individual narrow bandwidth, low deviation subcarriers for transmission of each discrete channel. At the receiving end of the link (downlink), the left and right audio channels are available to the studio equipment.

**Mainframes:**

The model 1601 Mainframe/Power Supply provides nine module slots to accommodate the 1600 family of products.

The model 1602 Mainframe/Power Supply provides two module slots to accommodate the 1600 family of products.

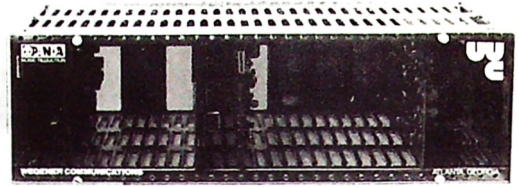

1601



1602

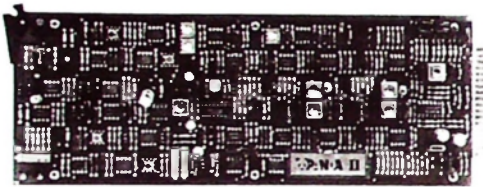

**1610 Panda II Demodulator**

The Wegener 1610 PANDA II Demodulator provides extremely high quality program audio demodulation of satellite and terrestrial subcarrier audio transmission utilizing the encode/decode process known as PANDA II.

A selection of audio bandwidth is available. Each demodulator contains a precision subcarrier demodulator, which is passed to the on board patented PANDA II processor to provide full bandwidth, 90DB dynamic range performance, exceeding CD audio quality, without quantizing errors.

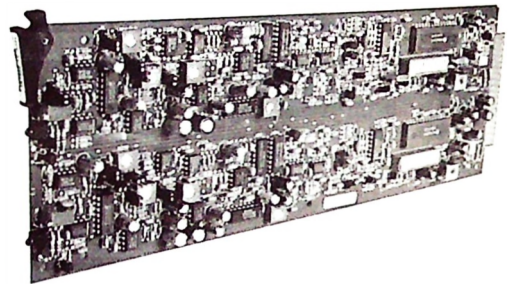

**Series 1620 PANDA 1 Demodulator**

The Wegener Model 1620 Agile PANDA® I Dual Channel Subcarrier Demodulator provides two high signal-to-noise ratio audio channel outputs. Based on the Wegener "Spectrum Efficient" narrow band subcarrier transmission standard, the Model 1620 demodulates subcarriers-above-video or FM<sup>20</sup> subcarriers. Each channel is DIP-switch tuned from 0.15 MHz to 8.2 MHz in increments of 2.5 kHz. Single channel units are also available.

The Series 1620 is a single printed circuit board which installs in a Wegener Series 1600 mainframe. Each channel utilizes independent circuitry for its signal path. Composite baseband containing subcarriers undergoes dual frequency conversion and filtering before compressed baseband audio is recovered by a pulse averaging FM discriminator. Unfiltered audio is monitored by an out-of-band noise detector which controls the squelch and alarm circuitry. The audiob is also low-pass filtered and expanded by the proprietary PANDA® I adaptive de-emphasis circuitry.

The expanded audio is passed through the squelch circuit, which provides muting when excessive noise is detected, then routed through the 75 usec de-emphasis network. The audio output amplifier provides a balanced 600 ohm output.



**DR96 Receiver**

The Model DR96 Digital Audio SCPC Receiver is a complete Single Channel Per Carrier receiver that derives either mono, dual mono or stereo audio channels from a digital data stream. MPEG compression technology permits high quality audio transmission while using considerably less satellite transponder bandwidth than standard analog techniques.

The Model DR96 contains an L-band tuner, BPSK or QPSK data demodulator, 1/2 rate FEC decoder, MPEG audio decoder, and the unit control. Contact Harris Allied for details on all of the various options. An example is the Addressable Network Control System (ANCS) for receiver control. All popular data rates from 64 to 192 kbps are available as standard product. This is the digital satellite receiver broadcasters have been waiting for!

**DTMF Controller Equipment**

Wegener DTMF encode and decode equipment uses standard dual tone signals to provide cue or signaling to the remote/receive site. DTMF are in the audible audio spectrum and as such will pass thru even low quality audio circuits. Generally DTMF tones are used between program sends, and allow up to sixteen functions to be signaled or cued per audio channel.

ENCODERS: Wegener 1699-01 6 function  
Wegener 1699-02 16 function

DECODERS: Wegener 1649-01 6 function relay contact output  
Wegener 1649-02 16 function hexadecimal output

# If We Don't Have It You Don't Need It.



Serving broadcasters on six continents and in more than 100 countries, we have become the world's leading distributor of studio, production, and satellite equipment, offering the widest range of radio products from a single source.



We deliver when you need it. Over 90% of our orders are shipped within 24 hours. Computer technologies and experience in transportation management, packaging and rate negotiations has resulted in the most efficient shipping and receiving department unsurpassed by our competition.

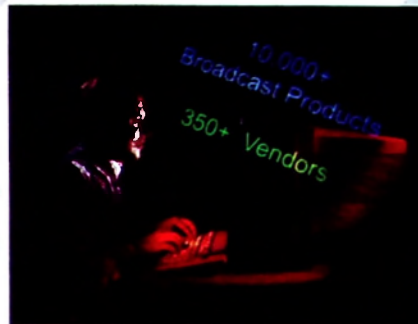

Our experienced broadcast professionals are working when you are—Monday through Friday, 8:00 a.m. to 8:00 p.m. Eastern. When you know what you need, you'll get the right price. When you don't, you'll get experienced advice.



Satellite products we distribute include reception equipment for digital or analog SCPC, audio or video subcarrier data, uplink and downlink antennas and support products. We are your primary source for the most innovative and effective technology.



With today's growing shortage of broadcast engineers, many broadcasters lack the technical staff to evaluate, maintain and service their equipment. We provide unparalleled customer support with experienced, certified service technicians.



Customer satisfaction is number one. Customer service representatives are ready to check your orders and answer any questions you might have. You can always count on fast, friendly service.

#### USA

Phone 317-935-1704  
Fax 317-966-0402

#### CANADA

Orders 1-800-269-6817  
Phone 514-421-6272  
Fax 514-421-2712

#### EUROPE

Phone +44 (0)223-415459  
Fax +44 (0)223-210441

#### LATIN AMERICA

Phone 305-266-8050  
**Mexico Only** 1-800-225-5433  
Fax 305-266-0401

#### ASIA PACIFIC

Phone 603-4569227, 4576222, 4566011  
Fax 603-4579240

#### FRANCE

TEL. 1/49 91 02 31  
TEL VOITURE: 07 03 52 40  
Fax 1/49 91 02 45

 **HARRIS** on the air  
**ALLIED**

### Sustaining Support: Our Philosophy

One of the most compelling reasons for selecting broadcast equipment from Harris Allied is the level of support you'll receive. We call it Sustaining Support, because its purpose is to sustain your equipment at a level which provides the highest return on your investment. We also want to sustain your confidence in Harris Allied as your preferred supplier, whether you select radio or television transmission equipment we manufacture, a system we integrate or a product we distribute. You may never have to call us, but you can always count on us if you need us.

### On Call, All the Time

No one can predict when an emergency situation will occur. That's why we support our transmission equipment and systems with 24-hour-a-day telephone service 365 days a year. We also provide extensive telephone support for radio studio products we distribute. Our service staff can work with your engineers to solve many equipment problems over the telephone.

Every call for technical assistance is entered in our computer database to ensure proper tracking and complete follow-up. Emergency off-air and under-power situations are given the highest priority.

When necessary, our field service engineers will be dispatched to help you resume normal operation as quickly as possible. Our field service personnel are also available to visit your site to provide scheduled maintenance and service, including installations, new equipment check-out, proof of performance and training.



### Parts: On Hand for Timely Delivery

Harris Allied's multi-million dollar inventory of spare parts enables us to respond quickly to the large installed equipment base around the world.

Our parts department is staffed around the clock, every day of the year, to ensure your emergency or general maintenance parts order is handled on a timely basis.



## On-Site Service, In-House Repairs

Harris-manufactured items small enough to ship can be repaired quickly and economically at our factory repair center. In addition, we offer over 60 different modules used in Harris transmitters through our module exchange program. Refurbished modules, which carry the same warranty as new modules, are available at lower cost. Harris Allied also repairs radio studio equipment from most of the 300-plus product lines we distribute and serves as a factory warranty repair center for many of these product lines.



## In-Depth Training

Whether it's general training for new personnel or specialized training on a new piece of equipment, only Harris Allied offers the extensive programs required to keep your staff knowledgeable.

We schedule approximately 30 RF training programs annually at our Broadcast Technology Training Center, the only facility of its kind in the world. Here we provide general RF training as well as programs on specific Harris transmitters.



To meet special needs, we can also design customized training programs on RF products, studio equipment and systems. These programs can be offered at Harris Allied or at any customer site.

## Sustaining Support: Our Commitment

Beyond quality products designed to deliver years of value, Harris Allied is committed to providing unparalleled Sustaining Support to protect your investment for the long term.

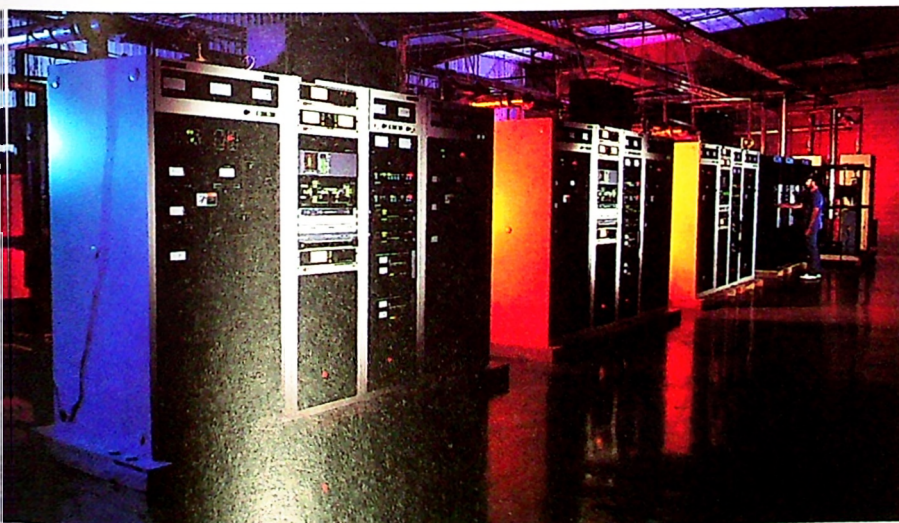

### SERVICE PHONE NO'S

RF Parts 217-222-8200 Ext. 3500  
Radio RF 217-222-8200 Ext. 3528  
TV & Sat. Sys. 606-282-4800  
Ext. 4830  
Sat. Audio 317-962-8596 Ext. 208  
TV RF 217-222-8200 Ext. 3177

## AEQ

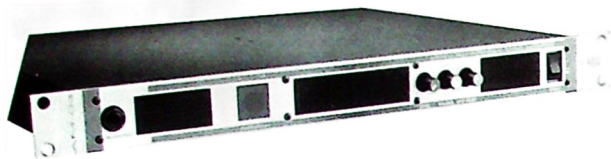
**AM-03 Self-Amplified Stereo Audio Monitor**

In just 1 RU of space, you can monitor up to three stereo audio sources along with an easy to read audio phase display. The AM-03 is a three-way system with a common center low frequency driver and two mid and high range drivers for both left and right. A front panel selector chooses one of three sources via rear panel XLR balanced high impedance connections. The output of the selector also feeds a pair of XLR rear jacks and a front panel 1/4" headphone jack. There is also an internal protection limiter on the speakers and magnetic shielding for use near video monitors.

## ALC

**10302 Announcer**

The ALC 10302 Announcer compact wood cabinet is perfectly square. The snap-away grill is 3/4" thick acoustically transparent foam. Frequency response is 60 Hz to 15 kHz,  $\pm 5$ dB. The system is protected by a 1 amp slow-blow fuse on the rear panel. Power handling capacity is 10 watts, nominal impedance is 8 ohms. Weight: 10 lbs.

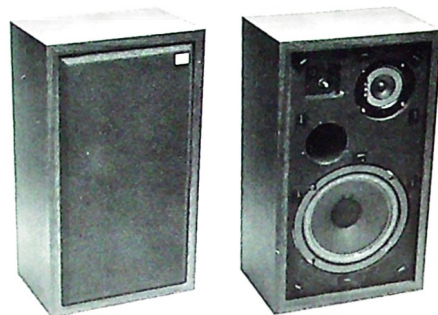
**20306 Monitor Loudspeaker System**

The Monitor loudspeaker system provides a flat response from below 50 Hz to beyond 20 kHz. Its high compliance surround on the 8" woofer and phenolic tweeter combine to enhance any type of music. The tweeter control and the system fuse are behind the snap-away grille. It will handle 25 watts RMS continuous, 45 watts integrated program material at 8 ohms. 19 1/2"H x 11"W x 7 1/4"D. Shipping Weight: 24 lbs.

## ELECTRO-VOICE



Sentry® 100A

**Sentry® 100A/EL Monitor Speaker**

The Sentry® 100A is a no-nonsense monitor speaker for the professional. Extended low frequency response, high efficiency and high power capacity make the Sentry® 100A the ideal choice for digital or analog monitoring. The constant directivity design provides more uniform dispersion for full frequency response over a wider area. A high power SUPERDOME™ tweeter and long throw 8" woofer are housed in a compact enclosure that is optionally rack-mountable. Shipping weight: 33 lbs. Also available is an amplified version, the Sentry® 100EL. Shipping weight: 37 lbs. 17 1/4"H x 12"W x 11 1/8"D.

S-40  
Compact Monitor**S-40 Compact Monitor**

The S-40 Compact Monitor is a "Small Wonder" with EV's PRO™ circuit independent woofer and tweeter protection, high-quality components with an optimized crossover and low-flux-leakage magnetic design. Convenient stand or wall mounting. Available in black and white. The S-40 has incomparable performance, unmatched versatility and incredible value.



Sentry® 500

**Sentry® 500 Monitor Speaker**

Offering superior low frequency response, the Sentry® 500 speaks to the needs of professionals with specific requirements. The larger

brother of the highly successful Sentry® 100A, the Sentry® 500 is designed to combine constant directivity, very low frequency response, efficiency and high power handling in a well thought-out package. Also available is the Sentry® 505, a downward angled version of the Sentry® 500.

### 4200 Series Studio Monitors

The 4200 series was specifically designed for use in the near field (on top of the mixing console). The unique Multi-Radial™ sculptured baffles direct the axial outputs of the 1in (25mm) titanium diaphragm tweeter and the woofer for optimum summing at the most common listening distance of 3-5ft (1-1.5m). The Multi-Radial baffle also positions the transducers to achieve alignment of their acoustic centers so low and high frequency information reaches your ears at the same time. Its magnet assembly is shielded to allow safe placement near CRTs, recorders and monitors. The model **4206** has a 6.5in (165mm) woofer and the **4208** is 8in (200mm).

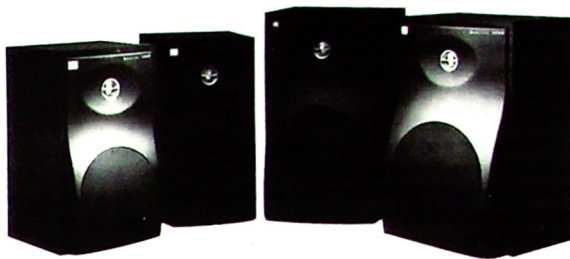

### 4400 Series Studio Monitors

If there is a standard on the industry for broadcast loudspeakers, the JBL 4400 series would be it. Using Symmetrical Field Geometry (SFG™) magnet structures, the 4400 series low frequency transducers minimize harmonic distortion, resulting in maximum definition of bass and low frequency information. A new titanium dome tweeter has been developed to further minimize distortion levels and they are oriented to create left and right models. The **4408A** is a 2-way 8in (200mm) compact system, while the **4410A** and **4412A** are 10in (280mm) and 12in (300mm) three-way monitors.

### Control 5 Wide-range Monitor

The JBL Control 5 is a high performance, wide range control monitor suitable for use as the primary sound source in a variety of applications. Molded of dense polypropylene foam, the Control 5 enclosure offers a pleasing shape that fits easily into any environment. Wall, ceiling, rack and tripod mounting systems allow positioning of the system in exactly the right spot for optimum performance. A 6½in (115mm) low frequency driver provides solid, powerful bass response to 50 Hz. High frequency response to 20 kHz is handled by a pure titanium 1in (25mm) dome.



Control 1



Control 1 Plus

### Control 1/Control Plus 1 Monitor

The JBL Control 1 is a high performance personal monitor loudspeaker. Incorporating a 5¼in (133mm) low frequency loudspeaker, ¾in (19mm) high frequency radiator and high performance dividing network, the Control 1 provides full-range, low distortion reproduction in a variety of applications. Compact and durable, the Control 1 mounting versatility is enhanced by a

complete line of installation accessories. Wall mounting brackets are available for permanent attachment to any rigid surface. A clamp mounting system is available for semi-permanent attachment to a wide variety of structures.

The **Control 1 Plus** models offer an improved woofer and a ¾in (19mm) titanium tweeter.

Certain products not available in some areas.



OMNIMOUNT



Model: CA-MP  
From ceiling  
to back of object.



Model: ST-MP  
From wall, ceiling or floor  
to top, back, bottom or  
sides of object.

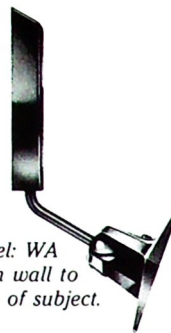

Model: WA  
From wall to  
back of subject.

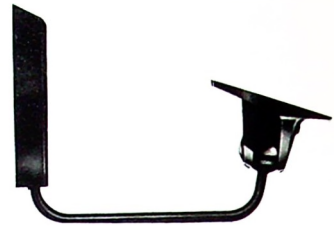

Model: WB  
From wall to bottom  
of object.

**OmniMount Universal Mounting Systems**

OmniMount Universal mounting systems offer an elegant, cost-efficient and safe method of mounting equipment in almost any location. OmniMount systems have been specified and are installed after a careful evaluation of the surfaces you will be mounting onto. Strength, composition and construction is taken into consideration for a safe and secure installation of equipment for everything from loudspeakers to security cameras. Objects to be mounted can weigh from 5 lbs. (2.3kg) to 225 lbs. (102kg). OmniMount assemblies are of industrial quality with good looks built to last. The heart of the system, a patented ball and clamp assembly, works with a variety of ball shaft lengths and bend configurations, wall brackets,

mounting plates, plumbing pipe, all-thread rod adapters and accessories — all in varied sizes and load-handling capabilities. OmniMount assemblies give omnidirectional adjustability, beyond the usual pan-and-tilt functions, combining omnidirectional movement of the clamp assembly with lateral and rotational movement of the tube - to get exactly the angle needed. Most models are available in satin black and Navaho white finishes, highly polished aluminum and steel is also available. Call today for complete specifications and details of what its made of and how it works. A mounting hardware reference guide is available for recommended wall or ceiling assembly.

**Harris Allied carries the entire line of OmniMount systems.**

FOSTEX



**6301B/BEAV Monitor Speaker**

The 6301B all-purpose powered monitor speakers are completely self-contained. The sound is delivered from a full-range speaker that's surprisingly flat and accurate. It is designed to handle the complex waveforms of complete songs. You get a frequency response of 80 Hz-13 kHz. The built-in 10-watt (RMS, into 8 ohms) amplifier will handle anything you feed it. A separate external speaker jack is also provided. 7 1/2"H x 4 1/4"W x 5"D. The 6301BEAV is the same as the 6301B with video shielding and XLR input. Shipping Weight: 6 lbs.

TANNOY



**PBM 6.5 II Series Monitor Speakers**

This newly updated classic maintains all the musicality of the original design and features a 6 1/2 in. injection molded woofer cone with a nitrile rubber mounting. It also has a 3/4 in. polyimide dome ferro-fluid cooled tweeter. It has a peak power rating of 100 watts RMS at 8 ohms and is finished in a pewter gray vinyl. Also pictured is the **PBM 8 II** which is similar in design, but with a 8" woofer.

**Harris Allied can supply the entire Tannoy line. Call for details.**

YAMAHA

**NS10MC Monitor Loud Speaker System**

The Yamaha NS10MC Commercial Monitor Loud Speaker System has been created specifically for close-field monitoring in professional sound studios. To achieve optimum performance in demanding professional applications. The NS10MC has been provided with plenty of power input capacity to handle the higher power levels required in the relatively "dead" acoustic environment of the professional studio. The high-end output of the NS10MC has been designed — on the basis of extensive testing and feedback from the field — to optimally match the monitoring conditions in the studio control room.



*Specifications subject to change or revision.*

# BEC TECHNOLOGIES



AD16 Transmitter

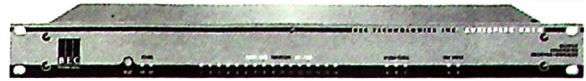

DA16 Receiver



FB-11 Fiber Optic Transceiver

## Proline Series Digital Snakes

BEC Technologies Pro Line Series can send 16 channels of "digitally clean" audio signals over a single twisted pair cable (and up to 64 channels bi-directionally on fiber optic cable). The unique Fault Tolerant Redundant Communications (FTRC™) provides redundancy on 4 separate outputs.

At the heart of the system is the **AD16 Input Converter - Transmitter**. It accepts up to 16 balanced line-level signals and converts them into a non-compressed digital data stream. Over a single twisted pair you can go 300' (91.44m) and 750' (228.6m) on two twisted pairs. If you connect a **Dataplex FB-II Fiber Optic**

**Transceiver** you can combine up to 4 AD16 outputs and transmit the multiplexed signal up to 2 miles (3.22 kilometers) bi-directionally.

The **DA16 Output Converter Receiver/Repeater** accepts the data stream either from the AD16 or the FB-II and converts it back into low-noise, full bandwidth analog signals. The system has a 90dB dynamic range, uses 64x over-sampling and includes cold system spares. Add the **MP16 Mic Pre-amplifier/Splitter** for up to 16 mic inputs. Phantom power and a 3 LED signal/clip indicator plus two discrete splits of line level outputs are provided.

# NVISION



## NV2000 Series Digital Audio Transmission System

The NV2000 Series Digital Audio Transmission System offers an integrated approach to multi-channel audio conversion, transmission and distribution requirements. Designed for telecommunications and audio transmission applications, the NV2000 Series can transmit and/or receive ten precisely phased channels of audio over a single coaxial or fiber optic cable. Up to twelve NV2000 System Modules may be installed in a single 2RU frame. The rack system includes a single power supply (110/240 VAC, 50/60 Hz) and power cord.

# QEI

## Cat-Link Digital Link

The digital STL/TSL for the 90's is QEI's Cat-Link, with advanced technology for flawless transmission and reception. Cat-Link consists of studio and transmitter rack mount units, each with room for up to seven modules. Input and output modules encode or decode the composite and auxiliary channels, using linear-phase FIR filters and a 70 MIPS DSP engine with 24 bit accuracy.

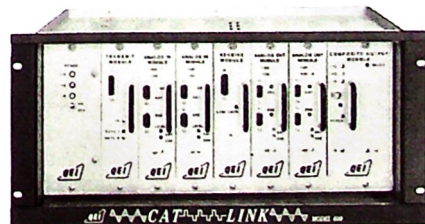

## INTRAPLEX

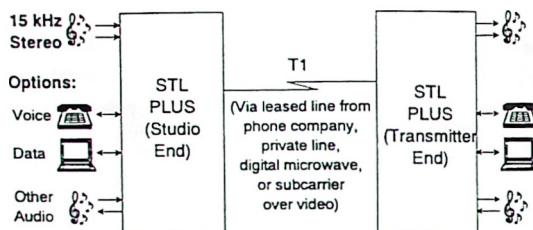
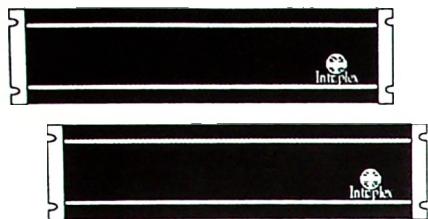
**Model 4200 STL PLUS System**

The Model 4200 STL PLUS is a stereo 15 kHz or 7.5 kHz digital STL that maintains compact disc audio quality by using discrete channel 16-bit linear coding with oversampling, resulting in greater than 90 dB dynamic range. And the STL PLUS uses no digital compression, making it an ideal choice for use where compression may occur at other stages of the audio chain.

The STL PLUS system employs T1 multiplexing, which provides a significant benefit not available from other STL products on the market: it allows you the option of adding your choice of one or more extra STL/TSL channels (voice, data, remote control, and 7.5 or 15 kHz audio), one-way or full-duplex, in the same circuit, without affecting the quality of the broadcast signal in any way.

The system includes the equipment for both the studio and transmitter ends of the link, and can operate over any type of T1 circuit: private line, leased line, digital microwave radio, or T1 subcarrier over an analog video microwave radio.

## RE AMERICA

**RE8721/8731 Stereo Tie Line Audio Codec**

Using 2B1Q four-level line coding as well as adaptive equalizers, the Tie Line Audio Codecs can transmit 15 kHz stereo audio up to 3.75 miles (6 km) over a twisted pair. The built-in adaptive equalizers automatically adjust to the actual cable lengths. Optionally a 1200 baud data channel can be transmitted with the audio.

## MARTI

**STL-15C Composite Studio Transmitter Link**

The STL-15C system uses the STL-15C Transmitter and the R-15C receiver to provide a link that can carry many different types of signals. Depending on available bandwidth, you can transmit composite FM stereo with two subcarriers, digital stereo audio (with external modems) multi-channel audio or data with external multiplexers or digital data with external modems. Complex systems with bi-directional capability, multiple relay or repeaters and automatic hot standby features can be configured. The STL-15C has a nominal 15 Watt RF output, frequency selection via DIP switches and selectable pre- and de-emphasis.

*Marti Continued on Page 146*



*STL-15C Composite Transmitter*



*R-15C Composite Receiver*

# A CREATIVE SOLUTION TO YOUR STL PUZZLE



If you've been puzzling over your STL options, consider how digital T1 fits.

A digital STL over T1 lines is a reliable, cost effective alternative to radio STL. T1 STLs handle CD quality uplinks and backhaul, as well as transmitter alarm monitoring and conventional voice with

ease. And, plenty of room to expand without FCC type approval concerns.

Intraplex offers the broadest range of digital T1 solutions for your STL, TSL, and LMAs. For creative digital T1 solutions to your STL puzzle, look to Intraplex.



## MARTI



STL-10



R-10

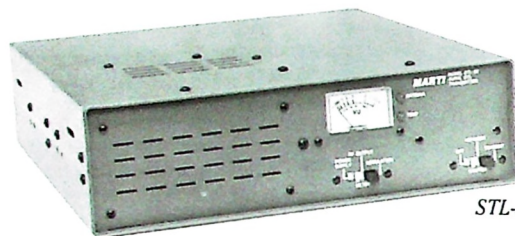

STL-30

## STL-10 Aural Studio Transmitter Link

The STL-10 is a single channel per carrier (SCPC) link that offers the highest stereo separation, signal-to-noise ratio, reliability and value in STLs. The transmitter features a precision bargraph modulation meter with a "peak-hold" that takes the guess work out of setting up your system and has a 10 watt RF output. The system can handle up to 4 subcarriers and has the inherent backup capability of SCPC. The system can be ordered on several different frequency bands between 140 MHz and 960 MHz, depending on your licensing. The receiver is the model R-10. There is also a STL-30 transmitter for use outside of the USA.

## TSL-10 Telemetry Link

The TS-10 can be used under FCC Part 74 in the 450-456 MHz band. It uses the RPT series of transmitters (RPT-30, RPT-15 or RPT-2) with the CR10 receiver. They have an internal AC power supply in both the transmitter & receiver with provision for external DC operation. Analog or digital telemetry or voice modulation with a 50 Hz to 2800 Hz bandwidth. You can also license under FCC Part 94 in the 928-960 MHz band, using the Marti STL-10 and R-10 transmitter and receiver. The system can then provide up to four continuous data/voice channels on a single carrier.

## MOSELEY

## PCL 6000 STL System

Moseley's PCL 6000 Series systems are fully synthesized with selectable mono or composite operation. Tuned and tested on operating frequency. 300-330, 450-470, 890-960 MHz. PCL 6020 — double conversion receiver, auto receiver transfer circuitry. PCL 6030 — triple conversion receiver, auto receiver transfer circuitry. Shipping weight: 43 pounds each.

## DSP 6000 Digital Transmission System

The DSP 6000 System offers broadcasters the digital transmission advantage. The encoder and decoder can be easily interfaced with any existing PCL 606/C or PCL 6000 series STL, and can convey up to four 15 kHz CD-quality audio channels and two data channels. The DSP 6000 now offers a choice of two source coders: The ISO/MPEG Layer II and a sub-band ADPCM source coder. The sub-



## Starlink 9000 Transmission System

The Moseley Starlink 9000 is the first all-digital, open-architecture, modular system for CD-quality audio transmission, facility remote control and Stereo/SCA/RDS generation. The versatility and power of the Starlink comes from a complete range of "plug and play" personality modules that can be housed in a user-defined choice of 1, 2, or 3 RU.



DIGITAL

band ADPCM encoder uses linear prediction and backward adaptive quantization to encode the difference between successive samples of music. The principle of the ISO/MPEG standard is based upon the psychoacoustic properties of the human ear. Source coder flexibility allows stations to tailor their sound according to interface of format considerations.

DIGITAL

## The Starlink 9000 personality modules are:

- Transmitter Module 200-2000 MHz
- Receiver Module 200-2000 MHz
- 16-bit Linear Digital Audio
- ISO MPEG/Sub-band or ADPCM Source Coder
- 103 bps/Hz Selectable Efficiency Channel Coder
- Drop/insert and Variable-Rate Multiplexer
- Digital Stereo Generator
- Digital SCA Generator
- Digital RDS Generator
- Speech/Fax/Data Card
- T1/E1/ISDN/Switched 56 Drivers
- Intelligent Remote Control
- Integrated Network Management





# The choice is now digitally clear...

*The new Moseley DSP 6000 Digital Transmission system will solve your STL problems. The system features:*

- CD-quality audio specifications
- Open architecture with AES/EBU I/Os
- 25 dB system gain improvement over analog STLs
- V.35/RS-422 interface for T1 applications
- Interfaces to any Moseley digital ready STL
- Low coding delay (3.8 ms)
- Expandable to four 15 kHz CD-quality channels

**Moseley**

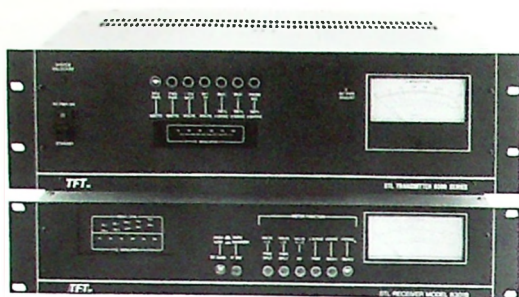

### 8300/8301B Composite STL

The TFT 8300/8301B Composite STL features a 10-14 Watt power output and exclusive 70 MHz IF repeater circuitry. The IF interface between the 8300 transmitter and 8301B receiver eliminates the audio deterioration inherent in the demodulation and remodulation that occurs in conventional receiver/transmitter relay configurations. This is particularly valuable in Digital STL applications.

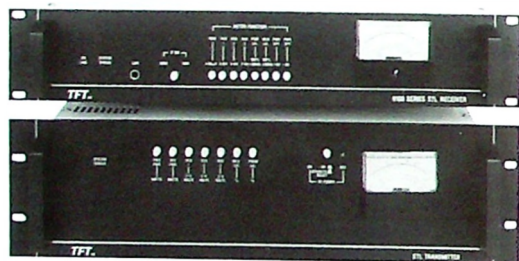

### 9100A/9107A Composite STL

The 9100/9107A is a frequency synthesized and agile Composite STL, available in all standard bands. The 9100/9107A is spectrum efficient and can achieve greater than 70dB SNR and 0.05% THD with only  $\pm 37.5$  kHz deviation.



DIGITAL

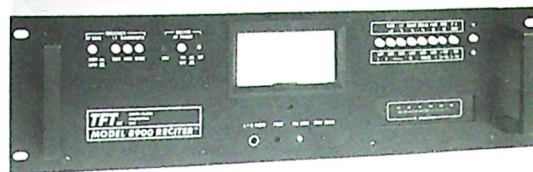

DIGITAL

### 8910 Reciter

Patented, revolutionary combination of STL receiver and FM exciter in a single unit. An IF interface which eliminates demodulation errors allows the Reciter to achieve better than 85dB SNR and less than 0.02% THD. Output power is adjustable from 5-50 Watts.



### 9200/9205/9205N Monaural STL

The 9200/9205/9205N is an economical frequency synthesized and agile Monaural STL, available in all bands. The 9200/9205/9205N is spectrum efficient and is available for 200 kHz (standard) and 100 kHz (narrow) RF channel spacing.

### DMM92 STL Multiplexer

The most spectrum efficient digital STL multiplexer modem available, the DMM92-100 offers up to four 15 kHz program channels plus two 3 kHz voice-grade channels in only 100 kHz of baseband bandwidth. The DMM92-75 offers two 15 kHz channels and may be expanded to include two 7.5 kHz and two 3 kHz channels in only 75 kHz of baseband bandwidth. Both models allow additional analog mix channels to be used on the baseband above 100 kHz. Forward Error Correction, Adaptive Path Equalization and a choice of integrated apt-X or external encoding.

*Harris Allied also handles all the accessories, antennas, cables, combiners, cavity resonators, etc., for your STL or TSL system. Contact us for more details. See Transmitter Accessories for subcarrier equipment.*



# DIGITAL STL BREAKTHROUGH

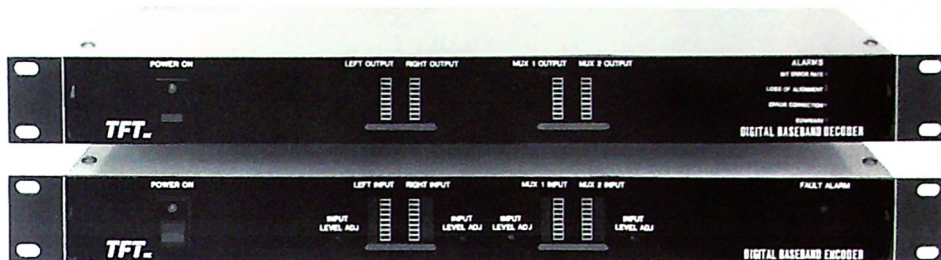

## *Introducing the TFT DMM92: The Better Digital STL System*

**W**ould you like to extend the fade margin of your existing analog STL by 20 dB or more? Extend Signal-to-Noise Ratio by at least 10db? Extend STL distance by miles? All with the bandwidth efficiency of 15-level duobinary modulation? There's just one digital STL system that lets you do it all— TFT's new DMM92. It works with your existing composite STL to give you vastly extended performance, and a whole lot more:

- ◆ **More Channels** —
  - ◆ Six audio channels, 4 program and 2 voice
  - ◆ Co-exists with FM SCA/MUX channels
  - ◆ AES/EBU and 32 kbps data channel available
- ◆ **More Flexibility** —
  - ◆ Internal, or external **apt-X** DIGITAL COMPRESSION, MUSICAM & Dolby audio codecs
  - ◆ Instant plug-in installation with virtually **any** STL
  - ◆ Useable for LMA's and duopoly applications
- ◆ **More Useable RF Spectrum** —
  - ◆ Six audio channels in a 250kHz RF slot
  - ◆ Perfect for highly congested markets
  - ◆ Tolerant to co-channel interference

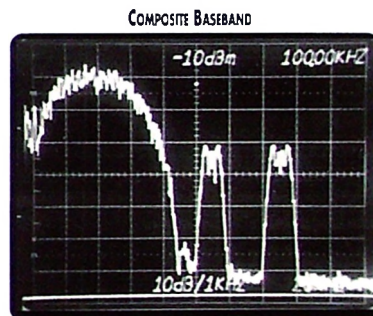

COMPOSITE BASEBAND  
2 x 15 kHz, 2 x 7.5 kHz, 1 x 9600 baud RS232, 110 kHz and 152 kHz Subcarriers.

*to complete the system:*

### **New TFT 9100 Composite STL**

- ◆ Ideal for use with DMM92
- ◆ Frequency-synthesized, field-programmable Tx and Rx
- ◆ Patented IF Modulation for superior performance
- ◆ Very sharp cavity RF filter, phase linear IF SAW filter



TFT 9100/9107 STL Tx and Rx.

*Sound Quality for over 20 Years*



## COMPLETE SYSTEMS CAPABILITY

Beyond offering more than 10,000 products from over 350 manufacturers, Harris Allied is a leading integrator of complete studio, mobile and RF systems. Our staff has the experience, the talent and the skills to completely design, install and document systems that professional producers and broadcasters require.

You can turn to Harris Allied for any level of assistance you desire, including system design, engineering, equipment selection and procurement, assembly, installation, testing, documentation, and maintenance.

With Harris Allied, you will find a system integrator with the stability of a large company and the long term expertise from decades in the broadcast/television industry. You will find a staff whose commitment to "value engineering" is backed by strong technical training and direct field experience. You will find a supplier with an unmatched understanding of current and emerging technologies — an understanding that comes from close relationships with end-users and major manufacturers whose products we represent. You will find a resource with field-proven systems and equipment in more than 150 countries worldwide, and an unrivaled reputation for superb after-sales support.



Master Control facility, Disney/MGM Studios, Lake Buena Vista, Florida



Three-channel automated master control system, News Channel 8 (Allnewsco) regional cable network, Springfield, Virginia

For more information or to discuss your specific system requirement, please call your Harris Allied representative or contact us directly:

**PHONE 606-282-4800**

**FAX 606-283-2818**



A Home Shopping Network control room, Tampa, Florida



Control console  
for 120 kW FM system

Fixed satellite installation  
at WCIV-TV Charleston,  
South Carolina

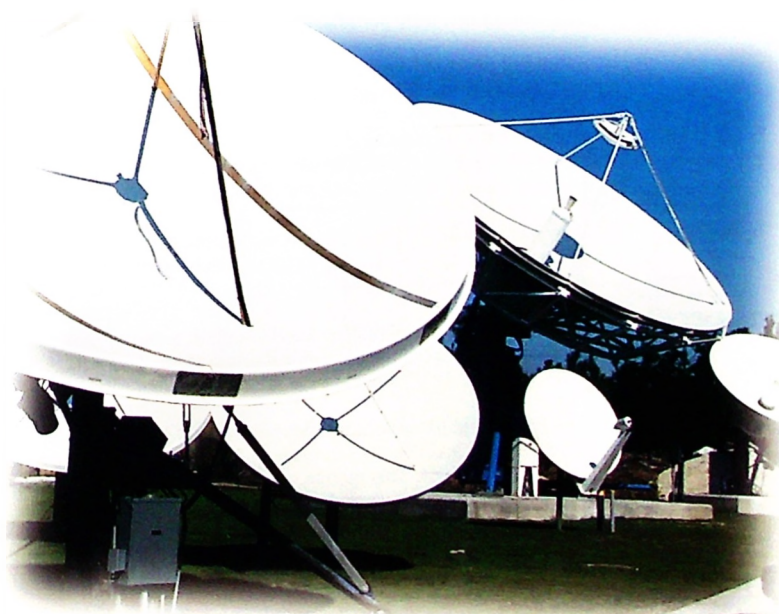

## You will find your Harris Allied system is:

**Cost-effective for the long term.** Your Harris Allied system will be designed to meet your budgetary requirements without compromising the long term cost-effectiveness of your operation.

**Designed for the future as well as the present.** Your Harris Allied system will be engineered with evolving technologies in mind, giving you a large degree of flexibility to add components that may not be currently available.

**User-friendly.** Your Harris Allied system will be designed to allow your staff to work productively without extensive training. Your system also will intelligently use technology in a manner that minimizes on-going labor requirements.

**Flexible.** Your Harris Allied system will be designed to give you maximum flexibility without costly equipment duplication. For example, by incorporating digital technology, automated machine control and high level patching in a production facility, our designers can create dynamic systems that allow several devices from various locations in a facility to be interconnected, allowing the user to create new system configurations. "Component-sharing" design can substantially reduce the amount of duplicate equipment.

For more information or to discuss your specific system requirement, please call your Harris Allied representative or contact us directly:  
**Telephone 606-282-4800 Fax 606-283-2818**

*Certain products not available in some areas.*



**MOBILE SYSTEMS FOR PRODUCTION, ELECTRONIC NEWSGATHERING, AND SATELLITE COMMUNICATIONS**

**MOBILE PRODUCTION SYSTEMS**

- M-1** Heavy-duty one ton van for small radio or television remote productions.
- M-24** Economic mid-size (14') vehicle for medium range production requirements. The M-24 is ideal for remote productions that require more than a van.
- M-30** Straight-body truck (up to 28') with full production capabilities. The M-30 is ideal for most remote production situations.
- M-40** The ultimate in mobile remote production systems. This 40 to 48-foot trailer is equipped for maximum production capability and is ideal for producing major sports, entertainment, or any other special event.

**MOBILE ELECTRONIC NEWSGATHERING SYSTEMS**

- M-1ENG** Mobile electronic newsgathering system with frequency-agile microwave transmission with dual aural subcarriers. The M-1ENG is available in a variety of chassis and with a multitude of configurations custom designed to meet your specific on-the-spot news coverage and live programming feed requirements.
- M-11ENG** This mobile ENG system is available in a variety of vehicle and system configurations and is ideal for the quick response news team. The M-11ENG is compact, highly maneuverable, and can get to places that are inaccessible to other ENG vehicles.

**MOBILE SATELLITE COMMUNICATIONS SYSTEMS**

- S-1 Flyaway** The world's first truly portable Ku-Band satellite uplink system. The 1.8 meter offset-fed antenna and all necessary electronic equipment is packed into heavy-duty cases, each weighing less than 100 lbs. The S-1's capability of uplinking live programs from anywhere in the world has been field-proven from Tiananman Square in China to a hotel rooftop in Baghdad during Operation Desert Storm.
- S-2 Flyaway** The S-2 is the next generation of high performance 'man-portable' satellite communication systems. With a 2.4 Meter antenna and the capability of utilizing both C- and Ku-Band frequencies, this system can be stowed into 18 cases that conform to current domestic and international baggage size and weight restrictions.
- S-18** Compact mobile Ku-Band satellite communications system equipped with a 1.8 meter offset-fed antenna. This system is perfect for uplinking news or special event programs. The system is easily adaptable for voice and data applications as well.
- S-21** Combines the latest in mobile satellite uplink technology with a full production system into a compact, yet comfortable mobile satellite communications system. The S-21 is available on a variety of chassis styles; in two body styles (11' and 12'6" lengths), and can be custom configured to meet your specific operational requirements.
- S-23** This mobile uplink system is equipped with a 2.6 meter antenna and can be configured to use either C- or Ku-Band frequencies. The operations area is spacious enough to accommodate the equipment necessary for full production capabilities. This mobile system has been field proven around the world to have the capability to uplink from areas previously considered impossible for antennas this size.
- S-30** This is the ultimate in C- or Ku-Band mobile satellite communications systems. The S-30 can satisfy remote uplink requirements from program origination, teleconferencing, or satellite newsgathering. The S-30 is available with either a 3.7 or 4.5 meter antenna system.

**KEY BENEFITS:**

- ▶ Complete range of video production, ENG and satellite vehicles in models for any remote application.
- ▶ Mobile units available with a variety of chassis.
- ▶ Interiors planned for most attractive appearance; maximum functionality and durability.
- ▶ Custom design and construction to meet individual specs.
- ▶ Full selection of equipment and options available for each model.
- ▶ Custom-integrated by staff which has provided *more* production broadcast vehicles worldwide over past decade than any other supplier.

## MOBILE PRODUCTION SYSTEMS HARRIS ALLIED M-1

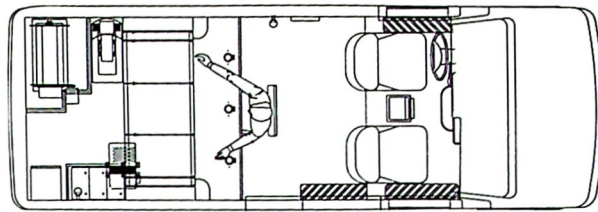

M-1 Floor Plan

The M-1 is available in a variety of vehicle brands and configurations. It can be equipped as a basic two-camera remote unit or a comprehensive three-camera system with editing capabilities. For the small television remote system, the M-1 is an ideal choice.

### VEHICLE FEATURES:

- ▶ Heavy duty one-ton van
- ▶ V-8 engine
- ▶ Full interior insulation
- ▶ Extensive custom design and construction to meet individual requirements
- ▶ 13,500 BTU rooftop air conditioner with 1.2 kW heater
- ▶ Full intrusion alarm system
- ▶ Lockable weathertight signal panel compartment
- ▶ Custom power control panel
- ▶ GFI protected exterior AC outlet
- ▶ AC line conditioning for rack electronics
- ▶ Full DC power system
- ▶ Plus many optional features

### TYPICAL EQUIPMENT:

- ▶ Two color camera systems, including CCU's, 5" viewfinders, 15:1 zoom lenses with studio controls
- ▶ Full camera support equipment
- ▶ Color and monochrome monitors
- ▶ Waveform and vector monitoring
- ▶ Broadcast quality video distribution
- ▶ Betacam or S-VHS VCR
- ▶ Eight-input video production switcher
- ▶ Video routing
- ▶ Character generator
- ▶ Audio mixing
- ▶ Stereo cassette recorder
- ▶ Audio monitor amplifier and speaker
- ▶ Plus many equipment options

## HARRIS ALLIED M-24

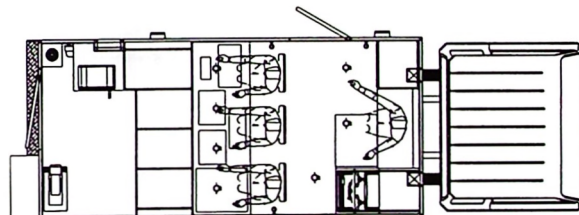
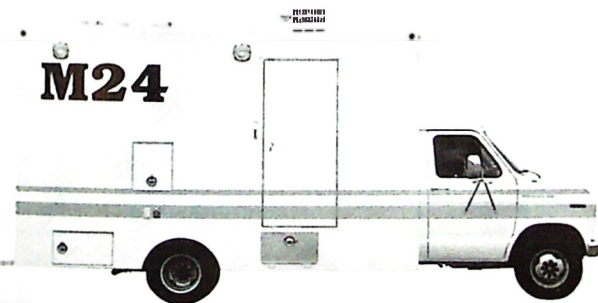

M-24 Floor Plan

The M-24 is a mid-size yet full-feature mobile production system in a cost-efficient package. It is available with either skin-and-rievet or custom-welded aluminum body construction. A variety of chassis styles is also available. The M-24 is ideal for medium-range production applications.

### VEHICLE FEATURES:

- ▶ Heavy duty one-ton van chassis
- ▶ Dual rear wheels for increased load capacity
- ▶ V-8 engine
- ▶ 14-foot aluminum body; skin and rivet or welded aluminum
- ▶ 7-foot interior height
- ▶ Full insulation
- ▶ Custom cabinets and racks
- ▶ 13,500 BTU air conditioner
- ▶ 1.2 kW heater
- ▶ Full security system
- ▶ Custom power control panel
- ▶ GFI protected AC outlets
- ▶ AC line conditioning for rack electronics
- ▶ Full DC power system
- ▶ Plus many opt. features

### TYPICAL EQUIPMENT:

- ▶ Three color camera systems, including CCU's, 5" viewfinder and 15:1 zoom lenses with studio controls
- ▶ Full camera support equipment
- ▶ Color and monochrome monitoring
- ▶ Waveform and vector monitoring
- ▶ Broadcast quality sync generation and video distribution
- ▶ Betacam or S-VHS VCR
- ▶ Timebase correction
- ▶ Full capability eight input production switcher
- ▶ Video routing
- ▶ Character generator
- ▶ Eight input audio mixer
- ▶ Stereo audio cassette recorder
- ▶ Audio monitor amplifier and speaker
- ▶ Plus many equipment options

**MOBILE PRODUCTION SYSTEMS  
HARRIS ALLIED M-30**

Systems



The M-30 is a full-capability remote system in a cost-efficient package. With a compact yet comfortable environment, it is ideal for most remote production applications.

**VEHICLE FEATURES:**

- ▶ Straight-body truck, up to 56,000 pound GVWR
- ▶ Welded aluminum construction
- ▶ Weathertight underbody storage
- ▶ Body lengths to 28 feet
- ▶ 7-foot interior height

- ▶ Custom cabinets and racks
- ▶ Three operational areas
- ▶ Air conditioning up to 60,000 BTU
- ▶ 10 kW heater
- ▶ Full security system, including underbody storage
- ▶ Separate custom power control panels for AC and DC with full metering
- ▶ GFI protected exterior AC outlets
- ▶ AC interior lighting with DC auxiliary lighting
- ▶ Full AC isolation and regulation for technical loads
- ▶ Full DC power system

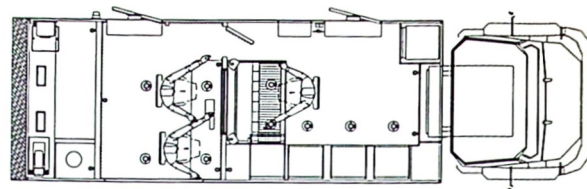

M-30 Floor Plan

**TYPICAL EQUIPMENT:**

- ▶ Four to six color camera systems, including CCU's, studio viewfinders, lenses with studio controls
- ▶ Full camera support equipment
- ▶ Extensive color and monochrome monitoring
- ▶ Waveform and vector monitoring
- ▶ Redundant sync generation, and pulse timing
- ▶ A variety of VCR formats available
- ▶ Production switchers with mix/effects banks
- ▶ Microprocessor-based AFV routing system
- ▶ Complete audio and video patching
- ▶ Broadcast quality graphics system
- ▶ Audio console up to 36 in and 24 out
- ▶ Full downstream audio processing
- ▶ Multi-format audio tape facilities
- ▶ Complete intercom/IFB system
- ▶ Multi-line telephone capability
- ▶ Various options - chassis, body, eq.

**HARRIS ALLIED M-40**



The M-40 is the ultimate remote production system. It is available in straight or expandable body styles in lengths up to 53 feet. The M-40 produces maximum production capability for sports, entertainment, and virtually any other major remote production application.

**VEHICLE FEATURES:**

- ▶ Insulated alum. and steel trailer
- ▶ Tandem ride air suspension
- ▶ Lockable weathertight underbody storage

- ▶ Trailer lengths to 48 feet & 7 ft. int. hgt.
- ▶ Custom interior, cabinets and racks available
- ▶ A variety of functional floor plans available
- ▶ Dual air conditioning systems provide 10 ton max.
- ▶ Complete trailer security system
- ▶ Separate control panels for AC & DC w/metering
- ▶ GFI protected exterior AC outlets
- ▶ AC interior lighting and DC auxiliary lighting
- ▶ Full DC power system

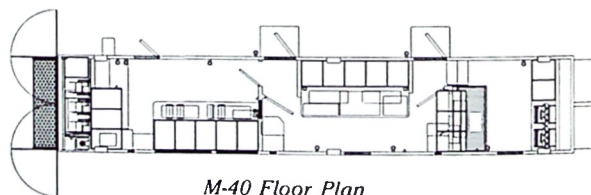

M-40 Floor Plan

**TYPICAL EQUIPMENT:**

- ▶ Up to eight color camera systems
- ▶ Complete color and mono monitoring
- ▶ Waveform and vector monitoring
- ▶ Dual sync generators, automatic changeover, and extensive pulse timing and video distribution equipment
- ▶ Full feature production switchers
- ▶ Microprocessor-based AFV routing
- ▶ Extensive audio and video patching
- ▶ Comprehensive graphics capabilities
- ▶ Audio console - 36 inputs, multichannel out & full equalization
- ▶ Full downstream audio processing
- ▶ Cartridge, cassette, and reel-to-reel audio tape facilities
- ▶ Extensive communications capabilities
- ▶ Opt. - flexible design & equip.



**MOBILE ELECTRONIC NEWSGATHERING (ENG) SYSTEMS**  
**HARRIS ALLIED M-1ENG**

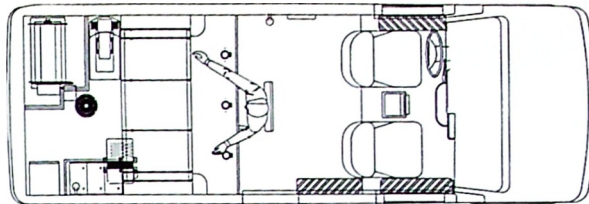

M-1ENG Floor Plan

**TYPICAL EQUIPMENT:**

- ▶ Portable color camcorder system
- ▶ Studio VCR editing system
- ▶ Color and monochrome monitors
- ▶ Waveform monitor
- ▶ Audio mixer
- ▶ 8 x 2 video/audio switcher
- ▶ Demodulator
- ▶ Off-air receive antenna

**EQUIPMENT OPTIONS:**

- ▶ Microwave transmitters, receivers and antennas
- ▶ Portable microwave systems
- ▶ Variety of tape formats available
- ▶ Color bar/source ID generator
- ▶ Video patching
- ▶ Audio patching

The M1-ENG meets the electronic newsgathering needs of most news operations and is available in a variety of vehicle brands and configurations. It is ideal for demanding live-on-the-spot news and programming feeds.

**VEHICLE FEATURES:**

- ▶ Heavy duty 1-ton van - V-8 eng.
- ▶ Custom individual floor plans
- ▶ 13,500 BTU rooftop AC w/1.2 kW heater

- ▶ Complete vehicle security system
- ▶ OSHA ok'd rooftop operation platform
- ▶ Two weathertight signal panel compartments
- ▶ Two GFI protected exterior AC outlets
- ▶ 4 kW AC generator & int. insulation
- ▶ Digital metering of AC voltage
- ▶ AC line conditioning for rack
- ▶ Heavy-duty 42-foot pneumatic mast
- ▶ Electrically-operated vehicle stabilizers
- ▶ Custom camera/VTR storage
- ▶ Full DC power system

**HARRIS ALLIED M-11ENG**

The M-11ENG, an all-purpose electronic newsgathering system configured in a rugged mid-size wagon-type vehicle, is built for budget-conscious news departments. This full-feature system includes two interior layouts and configurations — front-facing for interior sit-down operation, or rear-facing for stand-up exterior operation through the rear door — and can quickly and easily be field-converted from one configuration to the other. The M-11ENG is designed to take a two-person rapid-response news team and all of its equipment anywhere, from tight urban locations to the most isolated or seemingly-inaccessible rural sites.

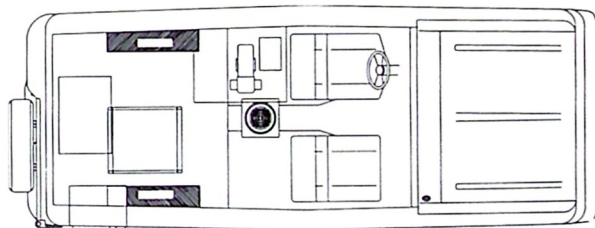

M-11ENG Floor Plan

**VEHICLE FEATURES & EQUIPMENT:**

- ▶ Variety of chassis available
- ▶ Heavy duty suspension & auto trans. w/OD
- ▶ Field-convertible interior layout and sys.
- ▶ Manual X-scissors leveling system
- ▶ Factory installed AC & heater
- ▶ 2.8 kW AC generator
- ▶ Multi-outlet AC strip, outlets in O/A
- ▶ GFI protected exterior outlet
- ▶ O/A Power Panel circuit breakers
- ▶ Analog metering of voltage and frequency
- ▶ Complete vehicle security system
- ▶ "Mast extended" transmission lockout system
- ▶ 2, 2.5, or 7 GHz microwave transmitter and power amplifier
- ▶ Semi-parabolic antenna, audio/video switcher
- ▶ Color monitor/receiver
- ▶ Color bar/ID generator, audio mixer
- ▶ VHF or UHF 2-way radio system
- ▶ Cellular phone, multiband scanner, IFB controller



Certain products not available in some areas.

**PORTABLE Ku-BAND UPLINK SYSTEM  
HARRIS ALLIED S-1 "FLYAWAY"**

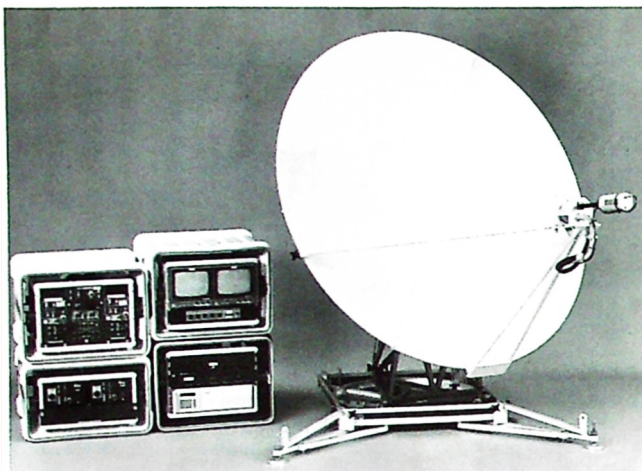

The S-1 'Flyaway' is the world's first high performance, truly portable Ku-band uplink system. It is entirely contained in 14 cases, each weighing less than 100 pounds and conforming to international baggage requirements. The S-1's 1.8M Vertex antenna has a transmit gain of 46.6 dbi and meets the 29-25  $\ominus$  FCC 2° spacing curves.

**FEATURES:**

- ▶ 1.8m antenna system,
- ▶ 200 watt phase-combined amplifier system
- ▶ High-stability Intelsat-approved Ku exciter
- ▶ Ku receiver and LNB
- ▶ Spectrum monitor
- ▶ Complete audio and video baseband package
- ▶ Setup time under 30 minutes
- ▶ May be checked as excess baggage on domestic and international airlines
- ▶ Field-proven technology
- ▶ Power requirements:  
— Two (2) 115 VAC 15 amp circuits; domestic version - one (1) 115 VAC 10 amp circuit.
- ▶ Available in PAL, NTSC, or multi-standard configurations
- ▶ Five antenna cases ranging from 58" x 11" x 11", 147.3cm x 27.9cm x 27.9cm to 35" x 35" x 10", 88.9cm x 88.9cm x 25.4cm
- ▶ Nine electronic cases ranging from 61 lbs., 27.8 kg. to 94 lbs., 42.8 kg.

**HARRIS ALLIED S-2 "FLYAWAY"**

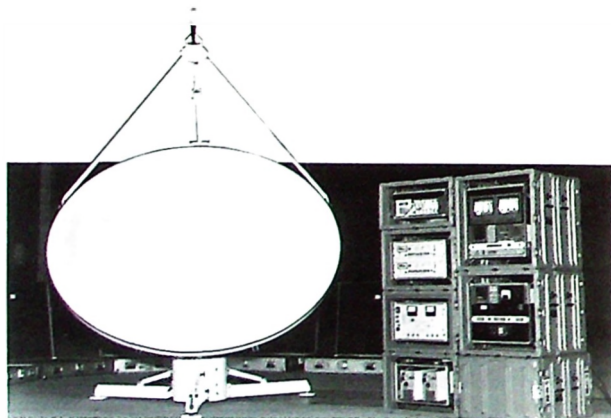

The S-2 "Flyaway" uplink system is the world's premiere high performance, totally "man-portable" C- and Ku-band uplink system. The entire system is packaged in 18 heavy duty aluminum/composite equipment cases, each of which conforms to international baggage size restrictions. The 2.4 meter Vertex antenna in the S-2 has a transmit gain of 49.0 dB and meets or exceeds the 29-25 FCC 2° spacing curves.

**FEATURES:**

- ▶ 2.4 meter antenna system
- ▶ 300 watt phase-combined amplifier system
- ▶ High-stability Intelsat-approved C- and Ku-band exciters
- ▶ C/Ku-band receiver and LNB
- ▶ Spectrum monitoring
- ▶ Waveform and vector monitoring
- ▶ Complete audio and video baseband package
- ▶ Setup time under 30 minutes
- ▶ Can be checked as baggage on both domestic and international airlines
- ▶ Field-proven technology

**POWER REQUIREMENTS:**

- ▶ International version: Two (2) 115 VAC 15 amp circuits
- ▶ Domestic version: One (1) 115 VAC 10 amp circuit
- ▶ Nine electronic cases ranging from 25" x 16" x 15", 63.5cm x 40.65cm x 38.1cm to 30" x 20" x 20", 76.2cm x 50.8cm x 50.8cm and weighing from 41 lbs., 18.6 kg. to 90 lbs., 40.9 kg.
- ▶ Nine antenna cases ranging from 38" x 23" x 21", 96.5cm x 58.4cm x 47.25cm to 73" x 12" x 8", 185.4cm x 30.5cm x 20.3cm and weighing from 134 lbs., 60.9 kg. to 51 lbs., 23.2 kg.

**HARRIS ALLIED AUTOMATIC SATELLITE INDICATOR/CONTROLLER**

An essential for *all* satellite vehicles enables personnel to locate and lock-on a satellite in three minutes or less using the proven Loran C navigational system, sophisticated sensors and state-of-the-art microprocessors to pinpoint satellite location and calculate and move antenna position, within  $\pm 2^\circ$  of elevation and  $\pm 1.5^\circ$  of azimuth. Many other features are incorporated.

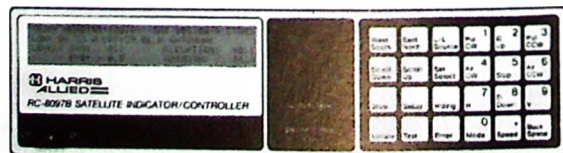

RC 8097B

## MOBILE SATELLITE COMMUNICATIONS SYSTEMS

### HARRIS ALLIED S-18

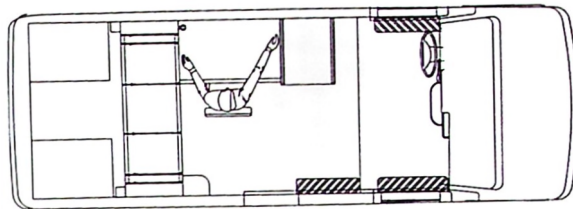

The S-18, a high performance satellite communications system, can maneuver easily in city traffic or on country roads. It uses a Vertex 1.8 m offset-fed antenna with a 46.6 dbi transmit gain for communications flexibility. The S-18 is ideal for uplinking news or special events and is easily adaptable for voice and data applications.

#### VEHICLE FEATURES:

- ▶ One-ton extended body van
- ▶ V-8 engine
- ▶ Complete insulation
- ▶ 13,500 BTU A/C with 1.2 kW heater
- ▶ Vehicle security system
- ▶ Weather-tight signal access panel
- ▶ GFI protected AC outlets
- ▶ Dual 6.5 kW AC generators
- ▶ Complete power metering
- ▶ AC conditioning for rack electronics
- ▶ Electric-operated vehicle stabilizers
- ▶ Full DC power system

#### TYPICAL EQUIPMENT:

- ▶ 1.8 m antenna
- ▶ 300 watt TWT amplifier
- ▶ Intelsat-approved Ku-band exciter
- ▶ Ku-band receiver and LNB
- ▶ Spectrum monitor
- ▶ Audio and video patching
- ▶ Video test generator
- ▶ AFV 10 x 1 switchers
- ▶ Color picture monitoring
- ▶ Waveform/vector monitoring
- ▶ Audio mixer and processor
- ▶ Audio monitoring
- ▶ Source/ID generator
- ▶ Many options available

### HARRIS ALLIED S-21

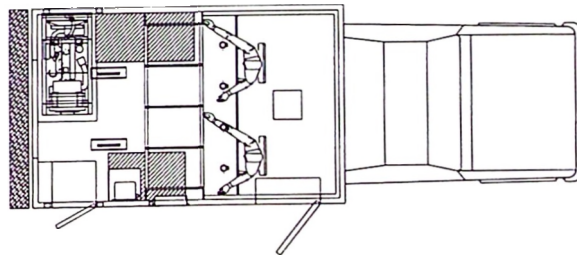

S-21 Floor Plan

The S-21 is a versatile and compact, heavy duty mobile satellite system. Equipped with its 1.8 m or 2.4 m, high gain, Ku-band antenna, and international power generation system, the S-21 can be adapted for a multitude of uses from spot news coverage or video teleconferencing to data transmission from remote locations. The S-21 combines both flexibility and equality into a compact self-contained, highly mobile unit.

#### TYPICAL EQUIPMENT:

- ▶ 1.8 m or 2.4 m Ku-band antenna
- ▶ 300 watt TWT power amp.
- ▶ Intelsat approved Ku-band exciter
- ▶ Ku-band receiver and LNB
- ▶ Spectrum monitor
- ▶ Audio and video patching
- ▶ Video test generator
- ▶ AFV 10x1 switchers
- ▶ Color picture monitoring
- ▶ Waveform/vector monitoring
- ▶ Audio mixer and processing
- ▶ Many equipment options

#### VEHICLE FEATURES:

- ▶ Choice of three chassis types (GVWR)
- ▶ Choice of two (2) insulated body sizes
- ▶ Choice of 3 engines
- ▶ Two 13,500 BTU air conditioner
- ▶ One 5,000 BTU heater
- ▶ Vehicle security system
- ▶ Weatherproof signal panel
- ▶ GFI protected AC outlets
- ▶ 15 kW AC generator
- ▶ Complete power metering AC line conditioning for rack electronics
- ▶ Four electric stabilizing jacks
- ▶ Full DC power system
- ▶ Two electronics rack configurations

## HARRIS ALLIED

MOBILE SATELLITE COMMUNICATIONS SYSTEM  
HARRIS ALLIED S-23

The S-23 is spacious enough for full production capability yet has excellent weight distribution and a wide GVW safety margin. The 2.6 m antenna, with a 50.1 dbi transmit gain, has been field-proven to uplink in areas previously considered impossible for antennas this size.

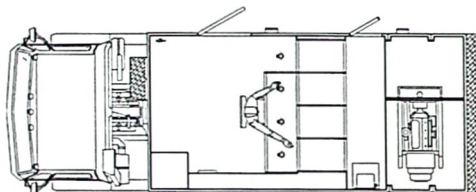
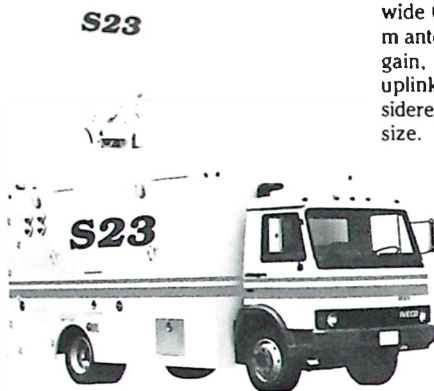

S-23  
Floor  
Plan

## VEHICLE FEATURES:

- ▶ Diesel power chassis
- ▶ All aluminum custom body
- ▶ Full insulation
- ▶ Dual 13,500 BTU central A/C
- ▶ Vehicle security system
- ▶ Lockable ext. storage compartments
- ▶ Custom cabinets and racks
- ▶ 15 kW diesel generator
- ▶ GFI protected AC outlets
- ▶ Custom power control panel
- ▶ AC power conditioning for technical loads
- ▶ Weathertight signal entrance panel
- ▶ Full DC power system

## TYPICAL EQUIPMENT:

- ▶ 2.6 m antenna
- ▶ 300 watt plate mounted TWT amplifier
- ▶ Intelsat-approved Ku-band exciter
- ▶ Spectrum monitor
- ▶ Audio and video patching
- ▶ Video test generator
- ▶ AFV 10 x 1 switchers
- ▶ Color picture monitoring
- ▶ Waveform monitoring
- ▶ Audio mixer and processor
- ▶ Audio monitoring
- ▶ Source/ID generator
- ▶ Numerous equipment options available

## HARRIS ALLIED S-30

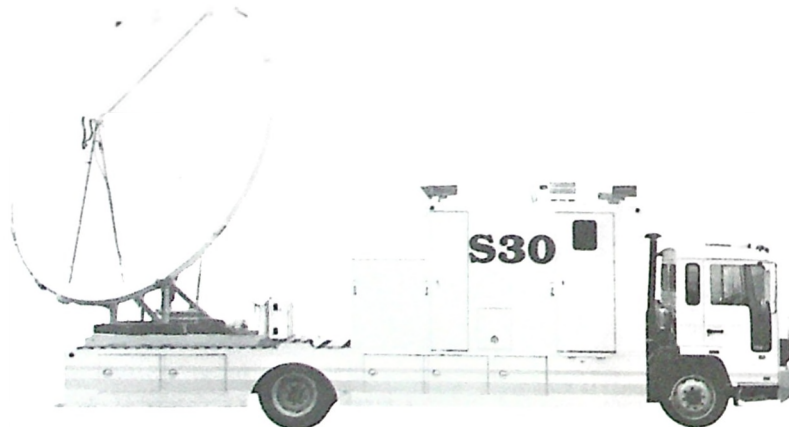

The S-30 — the ultimate transportable uplink system with 3.7 or 4.5 m antenna, in your choice of C or Ku-Band configuration. Whether your application is program origination, teleconferencing or news, the S-30 can satisfy your requirements.

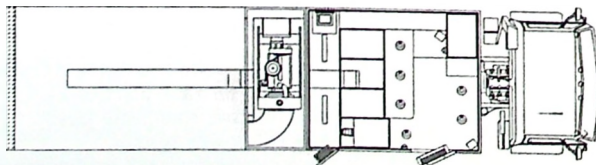

S-30  
Floor  
Plan

## VEHICLE FEATURES:

- ▶ Turbo 6-cylinder diesel engine
- ▶ Custom-welded all-aluminum body
- ▶ Full insulation
- ▶ Dual 15,000 BTU air conditioners
- ▶ 5,000 BTU wall heater
- ▶ Custom cabinets, racks & storable desk
- ▶ Ample interior and exterior storage
- ▶ Custom power control panel
- ▶ Metering for AC & DC voltage, AC current and frequency
- ▶ Stable antenna platform during operation
- ▶ Full DC power system

## TYPICAL EQUIPMENT:

- ▶ Two- or four-port 3.7 or 4.5 m antenna
- ▶ 300 watt TWT amplifier for Ku-band
- ▶ 3.3 kW klystron amplifier for C-band
- ▶ Intelsat-approved exciter
- ▶ Video test generator
- ▶ Audio and video patching
- ▶ AFV switching
- ▶ Distribution amplifiers
- ▶ Video monitoring
- ▶ Waveform monitoring
- ▶ Studio audio mixing
- ▶ Source/ID generator

## OPTIONS:

- ▶ Variety of vehicle mfr's and chassis available
- ▶ Camera systems
- ▶ Communication systems
- ▶ Video tape and production systems

Specifications subject to change or revision.



**556/64 DSU Interface**

The 56/64 DSU is a stand-alone or wall-mount DSU/CSU that provides interface between 56 kbps digital data service and the customer's data terminal equipment. It is available with a V.35 DTE interface and may be configured for point-to-point or multipoint operation.



**ISU 2x64 Interface**

The Adtran ISU 2x64 is a stand-alone service unit that connects data terminal equipment to the ISDN network. It is a dual port ISDN terminal adapter that is available with or without an integrated NT1. Features dual RS-530A/RS-232 DTE interfaces and dual RS-366 dial interfaces.



**DSU III AR Interface**

The DSU III AR is a technologically advanced, high performance DSU/CSU that provides an interface between digital data service, basic data services or 4-wire switched 56 and the customer's data terminal equipment. Also available: DSU III DBBU, DSU III S4W, DSU III S2W.



**ISU 128 Interface**

The ISU 128 is a stand-alone ISDN service unit that connects data terminal equipment directly to the ISDN network. It also includes NT1 network termination and terminal adapter functionality. The ISU 128 interoperates with Switched 56 DSUs, ISDN Terminal Adapters and more.



**NT1 ACE**

The NT1 Ace is a small stand-alone desktop unit that provides the network termination for 2B1Q ISDN basic rate service as well as a 2B+D basic rate interface between the data terminal equipment and ISDN network. ISDN PS2 and NT1 Power Supply Kit are also available.

CCS



**Micro 56+ Digital Audio CODEC**

The CCS Micro 56+ digital audio CODEC enables you to set up 77.5kHz audio feeds based on standard switched 56Kbps networks using terrestrial, fiber optic, ISDN or satellite facilities and implements the industry standard CCITT G.722 Mode 2 ADPCM algorithm for digital encoding. In 7.5x8" box.



**CDQ1000 Musicam® Digital Audio CODEC**

CDQ1000 Digital Audio CODEC, the newest member of the Musicam® family, is designed for radio broadcasters who want more audio bandwidth & fidelity. Using an enhanced Musicam compression at 24kHz sampling rate, its the first CODEC capable of transmitting full 10kHz of digital audio. Mono operation.



**CDQ2000 Multi-rate Digital Audio CODEC**

The CDQ2000 CODEC represents high quality digital audio encoding/decoding equipment combining digital signal processing with non-proprietary ISO MPEG audio compression. Its unique features allow you to manage digital bandwidth verses audio quality problems plus provide 20kHz of stereo audio in 112k bits of digital bandwidth.

Certain products not available in some areas.



**2XP Encoder**

The 2XP portable two-line encoder is for use with an external console, and contains all the features necessary to transmit 5 kHz over two dial or dedicated lines. There is built-in telephone interface for two program lines, with a third for communications. An optional road case is available. 4"H x 9"W x 14"D. Unit Weight: 9¼ lbs.



**3XP Encoder**

The 3XP encoder is compact, rugged and easy to use. It will automatically dial your program lines and send all necessary setup signals with the push of one button. There is visual indication of line integrity as well as monitoring on Line 3 for communications. Because real time audio processing is employed, there is no delay when monitoring program IFB.



**DX100 Digital Audio Encoder/Decoder**

The DX100 is a digital audio data reduction system that utilizes the apt-X audio coding algorithm. It achieves a fixed 4:1 compression ratio, allowing full bandwidth (15 kHz) mono audio transmission on a 128 KB/s data channel. Capable of wideband stereo at a data rate of 256 KB/s and works at other data rates (56, 64, 112, 224 KB/s) with varying audio bandwidth. An Inverse Multiplexer is included which will add together the data rate of two independent 56 or 64 KB/s data channels.

**DDXP/DXR Digital Audio Codecs**

Two digital audio compression devices from Comrex provide broadcasters with an economical alternative to satellite feeds or expensive dedicated circuits. The Digital Audio Codecs, a portable unit (DXP) and a rack mount system (DXR) for studio use, allow full duplex audio transmission with 7.5 kHz bandwidth. The Comrex DX system works with all 56 and 64 KB/s digital data services. Digital Signal Processing (DSP) technology is used to "squeeze" the wider broadcast bandwidth into a digital channel otherwise capable of carrying only standard telephone quality audio (300 - 3000 Hz).

The DX system can be used for audio links in network distribution, studio-to-studio links and STL applications.



**2XR Decoder**

The 2XR rack-mount two-line decoder is compatible with both 2XP and STLX encoders. For unattended operation, the 2XR may be used with TCB-2 auto-answer telephone couplers and the LX-L auto leveler, or with TCB-1 couplers where phones will be answered manually. 1¾"H x 19"W x 14"D. Unit Weight: 10½ lbs.

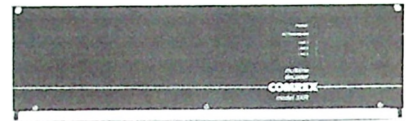

*The Comrex Multiline frequency extender system consists of the 3XP encoder and the 3XR decoder.*

**3XR Decoder**

The 3XR decoder contains everything necessary to automatically answer and match the gains of program lines as well as equalize each line across the full telephone band. It is housed in a 3U 19" rack and uses modular Eurocard board construction. Optional automatic satellite delay for international feeds will handle up to one second of time difference among lines.



*DX200, DX210  
DX220, DX230*

**MusicLine Digital Audio Codecs**

All MusicLine products have a built-in Inverse Multiplexer, (IMUX) which adds data capability of two, independent 56 or 64 KB/s channels so the codecs can be used on SW56, ISDN or dedicated digital lines. The IMUX may be disabled for use on T1, satellite channels or wireless modems. The encoders may be user-configured for stereo or mono operation.

The compact DXP, designed for field use, is 5¾" wide and weighs 3 lbs.

The DXR studio or fixed unit provides balanced, line level input and output.

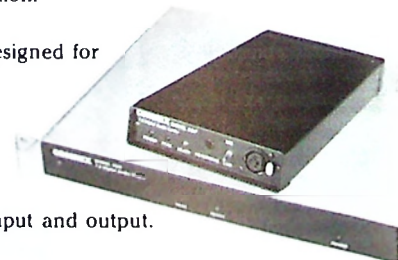

*Digital Audio Codecs — DXP (portable), DXR (rack-mount)*

*Specifications subject to change or revision.*



LX-T

LX-R

**LX-T (top) and LX-R (bottom) Extender Systems**

This basic extender system was specifically designed for smaller-market stations. The LX-T encoder/LX-R decoder doesn't offer the extra features that some users find unnecessary. What it does offer is a distinct improvement in program quality sent over telephone lines at the lowest possible price. Optional rack adapter available. 1 1/4"H x 9"W x 6 1/2"D. LX-T weighs 2 1/4 lbs. and LX-R weighs 2 1/2 lbs.



**TCB-1A Coupler**

Comrex's TCB-1 manual coupler provides a switched hold connection to a telephone line so that the telephone set may be hung up during program feeds. This eliminates the need for special telephone instruments with push-to-talk handsets or exclusion keys. Use with any modular phone to send or receive live or taped material. Does not interfere with normal use of the associated telephone instrument. Does not require batteries or external power. 1 1/4"H x 4 1/4"W x 3 3/8"D. Unit Weight: 9 oz.



**TCB-2 Coupler**

The TCB-2 auto-answer coupler automatically answers a telephone line on the first ring and disconnects that line when the calling party hangs up. The TCB-2 needs a momentary open or reversal from the central office to disconnect. Most, but not all CO's provide this signal. An optional dial tone detect board is available if required. Ideal for unattended situations such as "listen lines," dial up network, remote transmitter sites and satellite links. Optional external AC supply required which will power up to 4 couplers. 1 3/4"H x 8 1/2"W x 5"D. unit Weight: 1 lb. 2 oz.



**PLX Micro Encoder**

The PLX micro encoder works with cellular or regular telephones. It's a full-duplex, battery operated, one line extender that packs twice the features of older extenders into half the size. It has mic and tape inputs, AGC, monitor output and built-in coupler. Optional A/C supply available. Used with either the TH-X or LX-R.



**Talk Console**

The compact Comrex Talk Console unit is easy to set up and simple to use, wherever there is access to phone lines. It conferences two incoming phone lines with two microphone channels for a host and guest. Included in the talk show package are a dial pad with two telephone line inputs for both a single telephone line connection and an in-house multiline system. The Talk Console may be used with all Comrex Frequency Extenders and Digital Audio Codecs.



**TH-X Extender/Hybrid**

The TH-X extender/hybrid includes all the features of the TH-1 hybrid and adds a one line frequency extender encoder and decoder. The TH-X is ideal for use with the PLX micro for high quality on air conversation between field reporters using cellular or dial telephones and the studio host.



**SLX Encoder/Console**

Comrex's SLX one-line encoder/console is similar to the STLX. The SLX is a complete, self-contained remote broadcast package with the single-line encoder. 5 1/2"H x 15"W x 15 1/2"D. Weight: 15 lbs.



**STLX Encoder/Console**

The STLX encoder/console is a self-contained remote broadcast package incorporating a 2-line encoder and a complete telephone interface. Features include: 4 mixing chnls (2 mic/line), switchable AGC on all mic chnls and 4 headphone chnls. Wgt: 18 lbs.

**AEQ**



**TLE-02 Portable Mixer/Frequency Extender**

By means of the Frequency Extender and the digital hybrid incorporated in the TLE-02 it can be used with a cellular telephone so the user can link up with his radio or TV station. The TLE-02 is about the size of a small tape recorder, totally portable and offers many excellent features. Call today!

**ELGIN**

**2009-121 Listen Line**

Also known as the "listen line," the 20721 is expressly for use as an automatic answer device. It will automatically connect your mass feed to a network station simply by having the station call the number assigned to it. The 20721 must see a battery reversal or momentary open from the originating city. Multi-connector DA19603403+51225-1 plug and hood assembly optional.



2009-121



EC30A

**EC30A Voice Coupler**

The EC30A is a totally passive voice coupler that's also known as the "QKT." Total protection is afforded to the phone company's

circuits by installation of the EC30A. Elgin was the original manufacturer for the Bell QKT.

**EXCALIBUR**



**HC-1 Handi-Coupler**

The HC-1 Handi-Coupler is the quickest and easiest way to connect audio to a telephone. The HC-1 connects in series with the handset of any telephone using modular connectors and can be used with almost any telephone, single or multi-line, modern electronic or older key systems. Ideal for use in stations, on-air and production studios, newsroom and sales office. Can be used for playback and it doesn't mind RF.

**INC**



**CM-1056S 4-Wire Service**

The INC CM-1056S supports either switched or dedicated 4-wire 56 Kbps services. Applications are: data transfer at 56 Kbps; LAN internetworking; videoteleconferencing; group 4 facsimile; dial-up 7 kHz digital audio and data vaulting. Other features include: built-in comprehensive diagnostics; stored memory dialing (up to 25 numbers) and LCD info display.



**CM-1056DP 2-Wire Datapath® Service**

The INC CM-1056DP provides switched 56 Kbps CSU/DSU for 2-wire Datapath® service and supports synchronous and asynchronous data rates. Applications include: dial-up videoconferencing; dial-up 7 kHz digital audio; data transfer at 56 Kbps synchronous or 57.6 asynchronous; LAN interconnection for dial-on demand routing; high speed image transfer; group 4 facsimile and high-speed PC to PC data communications.

**INDY AUDIO**

**TC-1 Telco Auto-Coupler**

The Indy Audio TC-1 Telco Auto-Coupler answers an incoming call on the first ring, maintains the connection until the calling party hangs up, then releases the line and resets itself. It can feed audio down the line, take audio off the line for broadcast or be connected to a hybrid for directional communications. The TC-1 is powered by the phone line and require no connection to AC power.

*The TC-1 is ideal for listen lines, concert lines and weather lines.*



*Specifications subject to change or revision.*





## Digital Hybrid 1a

Using DSP technology, the Digital Hybrid 1a "auto nulls" every time it's activated to provide a match to that particular telephone line's characteristics. During the course of the call it monitors the line and automatically adapts to any changes that could create problems. If you have trouble with inconsistent telephone lines, you need Gentner's Digital Hybrid 1a.



## Digital Hybrid III

Gentner's Digital Hybrid III provides the consistent performance of a digital hybrid with the audio quality and extra features of high-end analog hybrid (the SPH-5). The Digital Hybrid III's AGC, automatic nulling and automatic re-null on new line selection provide the best performance from line to line. REC and CUE make it easy to use on and off air.



## EFT-3100 Digital Frequency Extender

Gentner's EFT-3100 delivers great sound. Providing a frequency response of 50 Hz to 7.5 kHz over 3 standard dial-up telephone lines. Using two lines, frequency response of 50 Hz to 5 kHz is possible. Standard features include speed dialing, automatic answer, automatic encode/decode, differential delay adjustment and line equalization. A system requires two units.



## EFT-900A Digital Frequency Extender

Gentner's EFT-900A makes remotes easy and inexpensive. The EFT-900A improves telephone audio quality by recovering 2½ octaves of low-end frequency response. Its sharp filters reduce line noise while Aphex® processing regenerates higher frequencies above 3 kHz. Easy to hook up and easy to use.

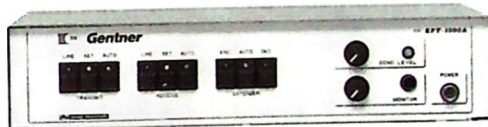

## EFT-1000A Digital Frequency Extender

The EFT-1000A extended frequency transceiver improves the sound of your telephone. Audio frequencies are shifted up by 250 Hz on the transmitting end and back down on the receiving end. It is a self-contained transceiver able to transmit, receive or operate full duplex as a transceiver. Easy hookup.



## G2500 Telephone Hybrid

The G2500 can be used with any audio board or console and its Auto Mix Minus permits you to feed program output down the telephone line, even when the output contains caller audio. Automatic answer/disconnect, nulling, re-null or new line selection, RS-232 control and single-cable conferencing.



## G2700 Digital Telephone Hybrid

Gentner's new G2700 DCT (Direct Connect Technology) Superhybrid is the first to give complete, direct access to your telephone system from your air studio. The G2700 DCT connects directly to standard telephone lines and it will digitally create its own "mix-minus" feed to the caller.



## TC-100R/TC-100RTT Telephone Coupler

The TC-100R is a versatile telephone coupler designed to provide auto-answer/auto-disconnect and latching or momentary tape starts. The unit can be used as a hybrid for on-air calls and as a remote controller and private party line telephone intercom. The TC-100RTT adds a Touch-Tone® decoder, which provides open collector output for incoming tones.



## G3200 Telephone Hybrid

Designed for large talk studios or talk shows with live audience, the G3200 combines digital hybrid technology and digital acoustic echo cancellation to provide clean telephone audio. The same automatic features as the G2500 plus a built-in auto mic mixer and power amplifier. Ideal for any talk show.

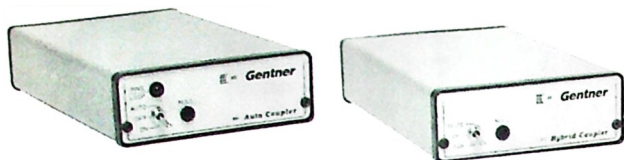

**Auto and Hybrid Couplers**

The **Auto Coupler** is an auto/answer, auto/disconnect telephone coupler with the versatility that makes it the ideal choice for all your coupling requirements. It incorporates a hybrid that allows you to send and receive audio simultaneously, providing balanced audio to your equipment. Easily connects to your telephone set and equipment. **CP Hybrid Coupler** is a versatile, inexpensive way to get clean, clear audio with easy installation and operation. It connects directly to the telephone line and can be used with almost all analog and digital telephone systems.



**SPH-3A Telephone Hybrid**

The SPH-3A is an analog telephone hybrid that provides front panel caller volume control and a two-watt monitor amplifier, also with front panel control. It's ideal for newsroom modules, dedicated guest lines, interviews and other professional and industrial applications.

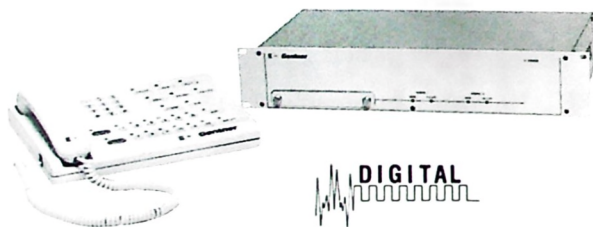

**TS612 DCT Multi-line Telephone System**

Gentner's new TS612 DCT (Direct Connect Technology) multi-line telephone system is for fast-paced broadcast telephone use, whether it's for contests, talk shows, business TV or audience interaction. The TS612 provides flexibility and expandability along with the following features: connection for 6 phone lines; on-air off-air talkability; space efficient; expandable control surfaces; built-in digital Superhybrids; a VIP button; a NEXT feature; RECOrd button; a MUTE function and 2 auxiliary buttons. All this and superb sound!

**TeleSwitch**

Gentner's TeleSwitch was designed to solve basic call directing needs. TeleSwitch allows you to connect up to 5 telephone lines. Multiple TeleSwitches can be linked to access more than 5 lines. Callers can be placed on-hold, conferenced, or recorded for later playback from the unit's control panel. TeleSwitch is as easy to install as a multi-line telephone and can be interfaced with most phone systems including PBX and EKSU. Most telephone hybrids compatible with TeleSwitch.



**Microtel**

How can you get your telephone remotes to sound good without employing communications engineers to set-up your remote? The answer is **Microtel**.

Microtel will allow you to do a quality sounding remote from almost any telephone without cumbersome or complicated setup. You'll be able to do more remotes and generate more income for your station. Microtel works with any remote broadcast equipment.



**SPH-5 Telephone Hybrid**

The SPH-5 is ideal for talk-intensive medium market broadcasters. In addition to superb telephone audio quality, the SPH-5 offers Gentner's exclusive REC (Record) and CUE (alternate send audio) features. REC starts your tape machine for recording calls; CUE permits talk with callers off-air.



**PeopleLink**

The PeopleLink modular telephone system can be operated simply with the touch of a button. It's a powerful, user-friendly multi-purpose system able to handle up to 40 lines. It works with any KSU and is expandable to your exact needs. Use as a stand-alone, on-air telephone system or in combination with your existing phone system. Existing external audio equipment can be directly interfaced to the system. VIP, contest, caller screening and other functions are available.

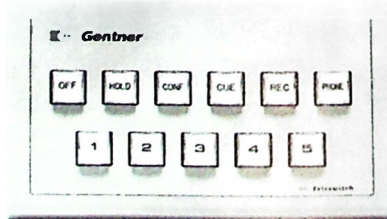

We're experts at connecting you  
with your listeners

 **Gentner**

SPH 3A

03300

## TRANSTREAM

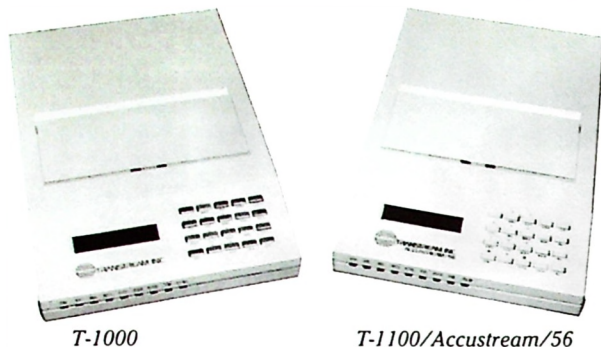

T-1000

T-1100/Accustream/56

Also available from Transtream  
T2002 ISDN Terminal Adapter

### T-1000™ Data Unit

The Transtream T-1000™ Data Unit (DU) provides user access to the circuit switched digital network through Northern Telecom's DMS-100™ Central Office, or SL-100™ PBX Switch. This allows 2-wire, full duplex, synchronous data transfer at speeds up to 64 Kbps, or up to 19.2 Kbps asynchronous. Also operates over local telephone public switched digital services.

### T-1100™ Data Unit

The Transtream T-1100™ Data Unit provides user access to the Circuit Switched Digital Networks as through AT&T's Accuunet Switched/56 service, etc. The T-1100™ also allows interworking with other switched/56 services such as United Telecom's Switch-link. It is designed to provide call progress detection for far end ringing, far end line busy and network busy to prevent unnecessary call holding time.

## HENRY



### DigiStor

DigiStor is a digital telephone message storage unit holding up to 4 minutes of digital audio for automatic playback to a caller. DigiStor can also be used as a stand-alone digital audio recorder/playback unit for utility use and all functions (Start, Stop, Record, Play) can be remotely controlled.



### TIS Telephone Information System

The TIS Telephone Information System is a comprehensive system for disseminating information via regular telephone line. It can store up to 8 minutes & 10 separate messages in its *digital* memory. Battery backup prevents memory loss during AC power failure. Microphone included.



### MixMinus Plus

MixMinus Plus is a differential summing amplifier designed to add a "Mix-Minus" output to a broadcast audio console, typically used to feed the send input of a telephone hybrid device. It subtracts the hybrid receive signal from program output, creating a program mix *minus* the receive audio.

## INTERALIA



### The Voice

The Voice is a 2 message/2 line solid state digital announcer designed to provide high-quality recorded messages for applications including ACD/UCD intercept, after hours, hotel wake-up, weather, sports and concert information.



### IP Interactive Announcing System

The IP Interactive Announcing System provides several recorded announcements for applications such as news, weather, sports, concert updates as well as a ski service hot line and a job line listing employment opportunities.

**Harris Allied carries Racom telephone interface equipment. The Racom 1700XT - TeleVote, a multi-channel voice storage and voting system and the Racom 1200L Digital Message Announcer. Both appear on page 69 in Digital Recorders and Players section.**

# "CLEARING THE AIR" WITH COST SAVING SOLUTIONS

**High Quality Sound At A  
*Fraction of the Cost*  
Using Switched 56/112 Lines  
vs.  
Satellite or Regular Analog Lines**

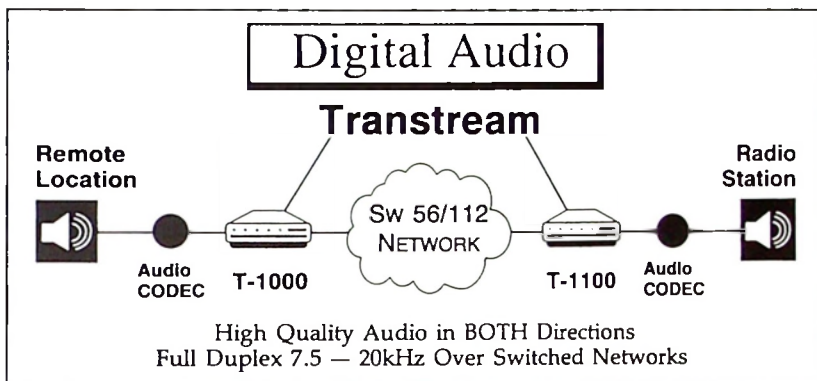

- ★ Remote Broadcasts
- ★ Dial up CD quality
- ★ Remote voice-overs



- ★ 2-way communication allows programming and cues to be carried on same circuit

**Transtream's  
Digital Modem™  
(T-1000/T-1100)**

*Let us help you the way we've been  
helping our customers since 1988*



**TRANSTREAM, INC.**

## RADIO SYSTEMS

### TI-101 Telephone Interface

The Radio Systems TI-101 Telephone Interface was designed specifically for the connection of professional audio equipment to telephone lines in broadcast and production operations. The TI-101 is a true hybrid. Call today for specific details.



## RE AMERICA

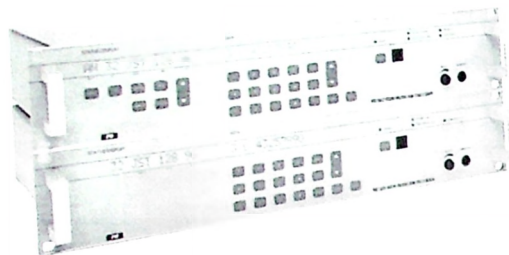

### 662 & 663 ISDN Musicam Codec

The RE 662 & 663 ISDN Musicam Codec is a full-featured digital audio codec which can encode and decode a mono, stereo or two channel program according to the Musicam ISO/MPEG layer II standard. The codec is intended for cost-effective transportation of audio signals on the Integrated Services Digital Network (ISDN). With this MUSICAM Codec, RE offers the broadcaster an audio pipeline to ISDN as easy to operate as a telephone.

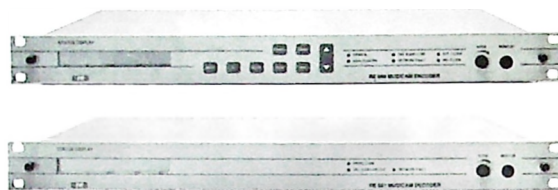

### 660 & 661 Musicam Codec

The RE 660 Musicam Encoder and the 661 Musicam Decoder make up a full-featured digital audio codec that can encode and decode a stereo or two-channel program according to the MUSICAM ISO/MPEG Layer II/IIa standard. The 660 & 661 Musicam Codec is intended for cost-effective transportation of audio signals on digital networks. The codec accepts analog as well as digital audio formats and compresses the audio information to a bit rate of 56 to 384 Kbps.

## SOUND AMERICA



### R/SVP Audio Coupler

The R/SVP is an audio coupler built in a standard USA-made 2500 series touchtone phone. The panel on the phone base features a SEND jack (8 ohms) for direct connection to play cassette recorder (or other electronic source) back down a telephone line; and RECORD jack (low imp.) to provide clear balanced signal to record both sides of conversation. The amplified electret condenser microphone provides superior voice quality. Comes complete with modular plug line cord. Telephone included.



### Voice-Act

Voice-Act makes it possible to transmit any electronic audio material source by telephone. The unit is comprised of microphone, external input jack, a function selector switch, a transistor amplifier and a stainless steel multi-layer windscreen. Voice-Act simply screws on in place of the regular phone transmitter and does not interfere with normal phone operation (may be left on permanently). Powered by the telephone, it requires no batteries. Specify type of phone when ordering.

## TELLABS

### Equalization Equipment

Tellabs equalization equipment was designed expressly for use with telephone circuits. No other form of equalization can offer the flexibility or specs necessary to achieve the quality for AM and/or FM (stereo) feeds via leased telephone circuits. If a circuit is unloaded and if the length vs. gauge criterion is not exceeded, you can install your own equalization and pay for it in a very short time. There's no reason for you to also pay for the equalization on a monthly basis.

- \*4008 EQ module
- \*4425 repeat coil/dual
- \*1913 dual card housing
- \*1911 single card housing
- \*1912 apparatus case
- \*8015 transformer
- \*248RF dual amp mounting, RF shielded.
- \*8003 power supply
- \*1012 housing



#4008



#4425

**ID-1200 Digital Frequency Counter**

The Digimax digital frequency counter meets or exceeds all FCC requirements. The D-1200 offers a frequency range of 20 Hz - 11.0 GHz, full 9-digit readout, sensitivity of 5 to 50 mV from 50 Hz to 25 MHz, 15 to 50 mV from 25 MHz to 450 MHz, and 50 to 75 mV at 1 GHz. Accuracy of  $\pm 1$  Hz at 1 MHz,  $\pm 1$  Hz at 10 MHz,  $\pm 100$  Hz at 1 GHz. AC-12 required for 110VAC, 8-15VDC at 500 ma. Package includes AC adapter, rechargeable battery pack and antenna.

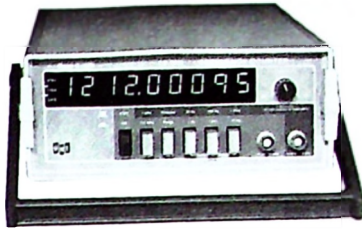

**CRL**

**DAA-50 Digital Audio Analyzer**

Compact and lightweight the CRL DAA-50 gives a comprehensive analysis of digital audio signals. It can receive and decode audio data according to interface standards. It identifies the signal format through LED status indicator lights. Balanced or unbalanced inputs signals are accepted and the DAA-50 checks your transmission link for errors and reports the status. Call Harris Allied today for complete information on the DAA-50 and on CRL's **DAA-100** Digital Audio Path analyzer and Digital Audio test signal generator.



**ATI**

**NG-1 Audible Noise Generator**

The NG-1 Audible Noise Generator from ATI is a useful tool for broadband level matching of multiple microphones in studios, teleconferencing rooms and A/V installations. The NG-1 is an excellent source of background masking noise for injection into office background music systems or via direct acoustic radiation into small rooms. The Pink Noise output of the NG-1 is optimum for measuring room response peaks and valleys using a sound level meter in conjunction with a one-third octave response tuned voltmeter or analyzer.



**FOSTEX**

**TT-15 Test Tone Oscillator**

The Fostex TT-15 test tone oscillator features user-selectable 40, 400, 1 K, 10 K and 15 kHz internal oscillator test tones. The 0 dBV output is ideal for broadcast use. -10 dBV and -30 dBV levels are also selectable. The TT-15 is powered by a 9V battery which, under normal use, will power the TT-15 for up to 30 hours. 4 1/16" H x 1 3/16" W x 3" D. Weight: 11 1/2 oz.



**GOLDLINE**

**DSP-30 Audio Spectrum Analyzer**

The DSP-30 is the first in a series of Gold Line Audio Spectrum Analyzers. The DSP-30 is the first analyzer to make measurements in 1/4 or 1/2 dB steps which means that it will speed up service time. With options it will print or go to hard disc via an RS232 port.



**LEADER**

*Harris Allied carries the entire Leader product line.*



**5864A Waveform Monitor/5854 Vectorscope**

Model 5864A Waveform Monitor from Leader offers a two-input, full monitoring facilities for cameras, VCRs and video transmission links. Model 5854 is a dual channel compact vectorscope providing precision checkout of camera encoders and camera balance, as well as precise genlock adjustments for two or more video sources.

**STL**

**Test Tapes**

STL test tapes are recorded directly from precision generating equipment to provide the most accurate reference possible. An independent standards laboratory, STL provides a completely objective service, with test tapes available to major manufacturers, governments and all who need a precision reference tools.





**224 Digital Storage Oscilloscope**

The Tektronix 224 is a hand-held battery operated, digital storage oscilloscope. Standard 60 MHz bandwidth, 10 MS/s sampling rate, RS-232-C interface and digital storage capabilities in a 2 kg (4.4 lb) package. Automated setups and waveform storage offer ease-of-use productivity. Define up to 4 front-panel setups in memory, recall with the press of a button.

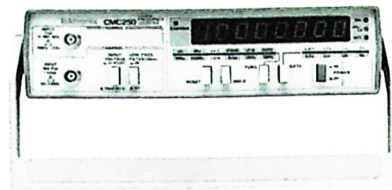

**CMC250 Multi-function Counter**

The CMC250 from Tektronix is a multi-function counter in a compact package. The CMC250 offers many useful features and can be stacked with others of the series. With 0.1 Hz resolution, totalize and period measurements, the analysis of a wide variety of signals is possible. The prescaled 1.3 GHz enables easy RF measurements.

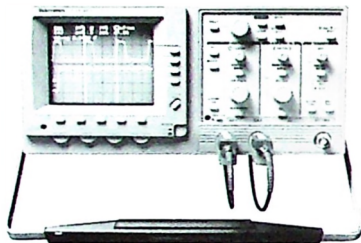

**TAS465 Portable Analog Oscilloscope**

The TAS465 from Tektronix is a 2-channel portable analog oscilloscope with 20 MHz to 200 MHz bandwidth selection. 100 MHz, 3.5 ns peak rise time. Basic performance 2205/2205 Option 40.



**TDS320 Digital Real Time Oscilloscope**

The TDS320 digital real time oscilloscope features oversampling digitizing technology. Full bandwidth single-shot waveform capture. RS-232, GPIB, Centronics Interface Option.

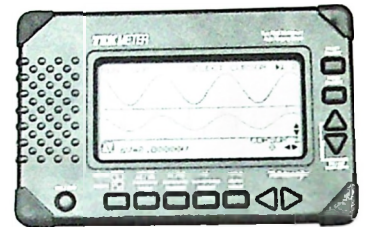

**TekMeter™ Multimeter Auto Ranging Scope**

The TekMeter™ Series combines a true RMS digital multimeter and a 25 MS/s digital storage oscilloscope designed to measure and display signals from a few millivolts to several hundreds of volts.

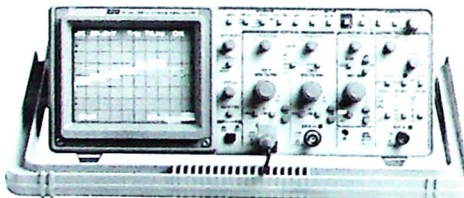

**2212 Programmable Portable Oscilloscope**

The Tektronix 2212 is a programmable portable oscilloscope with both analog/digital capabilities. 60 MKz bandwidth, 20 MS/s sampling rate per channel, 8-bit vertical resolution, 4K record length per channel with 128K record length optional. Autoset, on-screen cursors, CRT readout and hardcopy printer parallel interface. Other optional features available.



**2221A Analog/Digital Oscilloscope**

The 100 MHz Tek 2221A analog/digital oscilloscope offers fast, 100 MS/s sampling simultaneously on 2 channels, selectable 1K or 4K record length and 10 ns peak detection for accurate signal capture, on the bench or in the field. Ideal for circuit troubleshooting and viewing complex signals. Freezes events on-screen for analysis. Other packages also available.



**AT-51 Audio Test Set**

The AT-51 is designed primarily for broadcast proof-of-performance measurements. The new AA-51A Audio Analyzer adds a digital

frequency counter readout, in addition to measuring THD, IMD, Volts, Signal+Noise/Noise, stereo phase and ratio and wow/flutter. It is compatible with NAB test CDs. The AG-51 Audios Generator supplies all the proper test tones for the AA-51A with simultaneous left and right balanced outputs at levels up to +20dBm. The outputs may be switched for left only, right only, L+R in phase and L-R in phase opposition.



THE DIGITAL PATH FROM SOURCE TO TRANSMITTER.

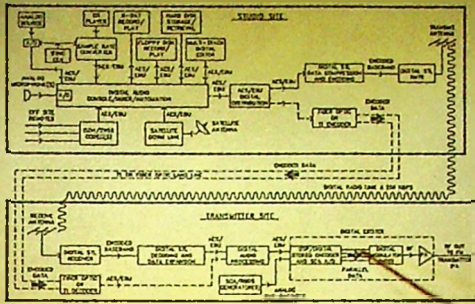

## Education and Training: Our Philosophy

Proper operation and maintenance of broadcast equipment impacts its long-term reliability. Our philosophy is to provide engineers with the skills and knowledge required to ensure maximum equipment longevity and performance.

### The Harris Broadcast Technology Training Center

Harris sponsors the world's only Broadcast Technology Training Center. Since its inception in 1975, more than 2500 broadcasters from around the world have participated in our RF training programs. Each year we offer about 30 regularly scheduled programs for engineers at all levels of experience.

To meet special needs, we also design customized training programs for broadcasters which can be taught at Harris Allied or at any customer site.

### General Training

General RF training programs are normally offered two times a year at the Center and include:

- AM Transmitter Workshop
- FM Transmitter Workshop
- TV Transmitter Workshop
- RF Circuits I
- RF Circuits II

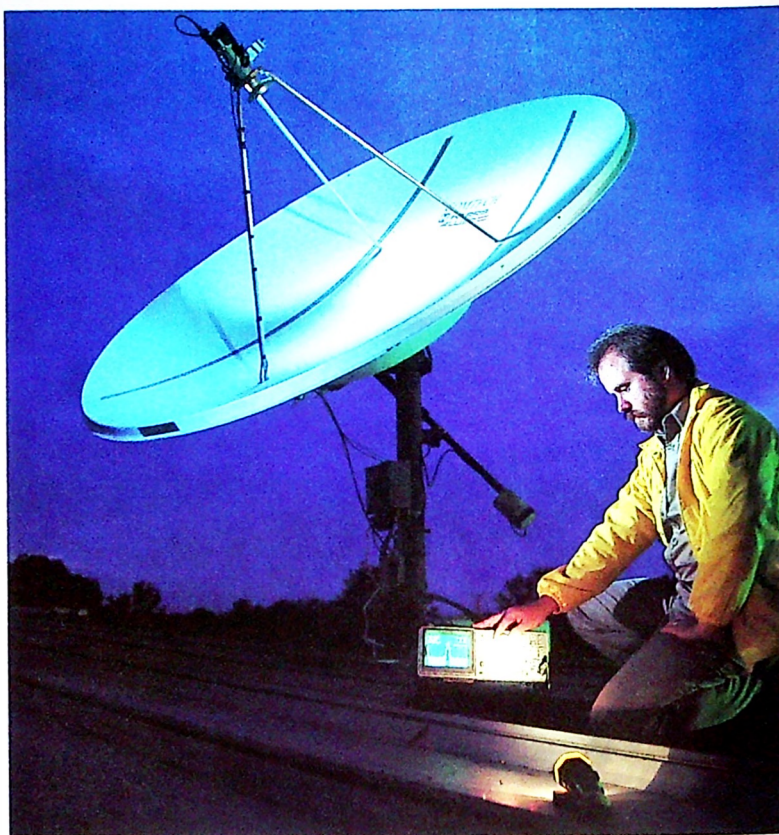

**Specialized Training**

Programs focusing on specific families of Harris radio and television transmitters are also offered. This "hands-on" training allows engineers to perform actual procedures and solve real-world problems associated with operation, maintenance, troubleshooting and repair.

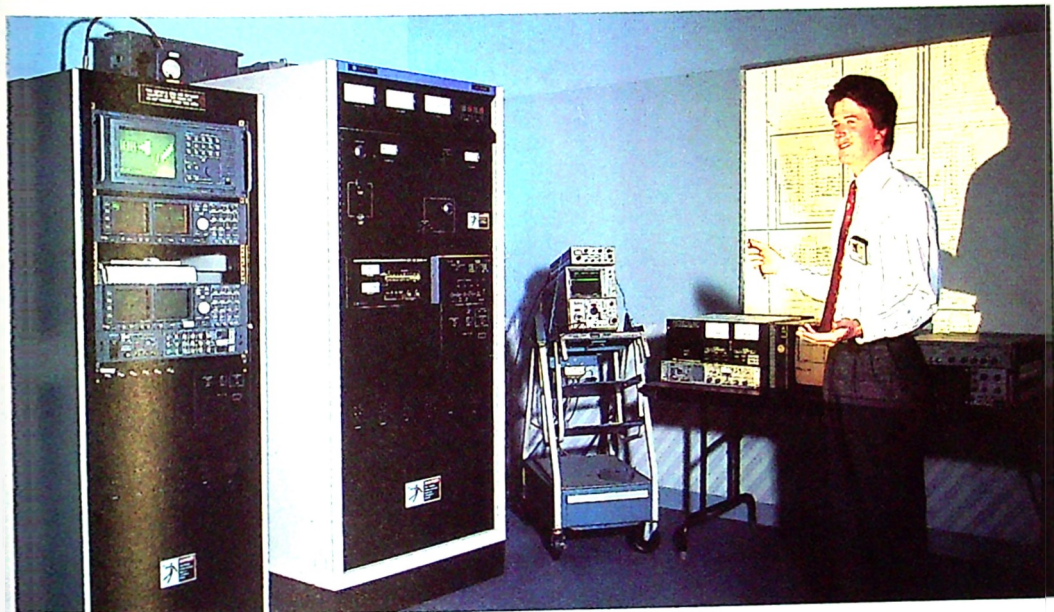

**Beyond Training: An Education**

More than a decade ago, Harris joined forces with John Wood Community College in Quincy, Illinois, to offer a fully accredited two-year program in Broadcast Technology, leading to an Associate's degree and SBE certification.

Since 1979, more than 250 students have graduated from this program, and over 90 percent of them have been employed in the electronics industry.

Others have transferred to four-year colleges and universities to complete Bachelor of Science requirements.

In addition, Harris offers an annual two-week training program for broadcast engineers from developing nations under the auspices of the United States Telecommunications Training Institute. Since 1983, over 180 engineers from 52 countries have participated in this joint Harris/USTTI program.

**Our Commitment**

In addition to offering quality products designed to deliver years of value, Harris Allied is committed to providing unparalleled training for operating and maintenance personnel today and supporting broadcast technology education for tomorrow.

# Extinction.

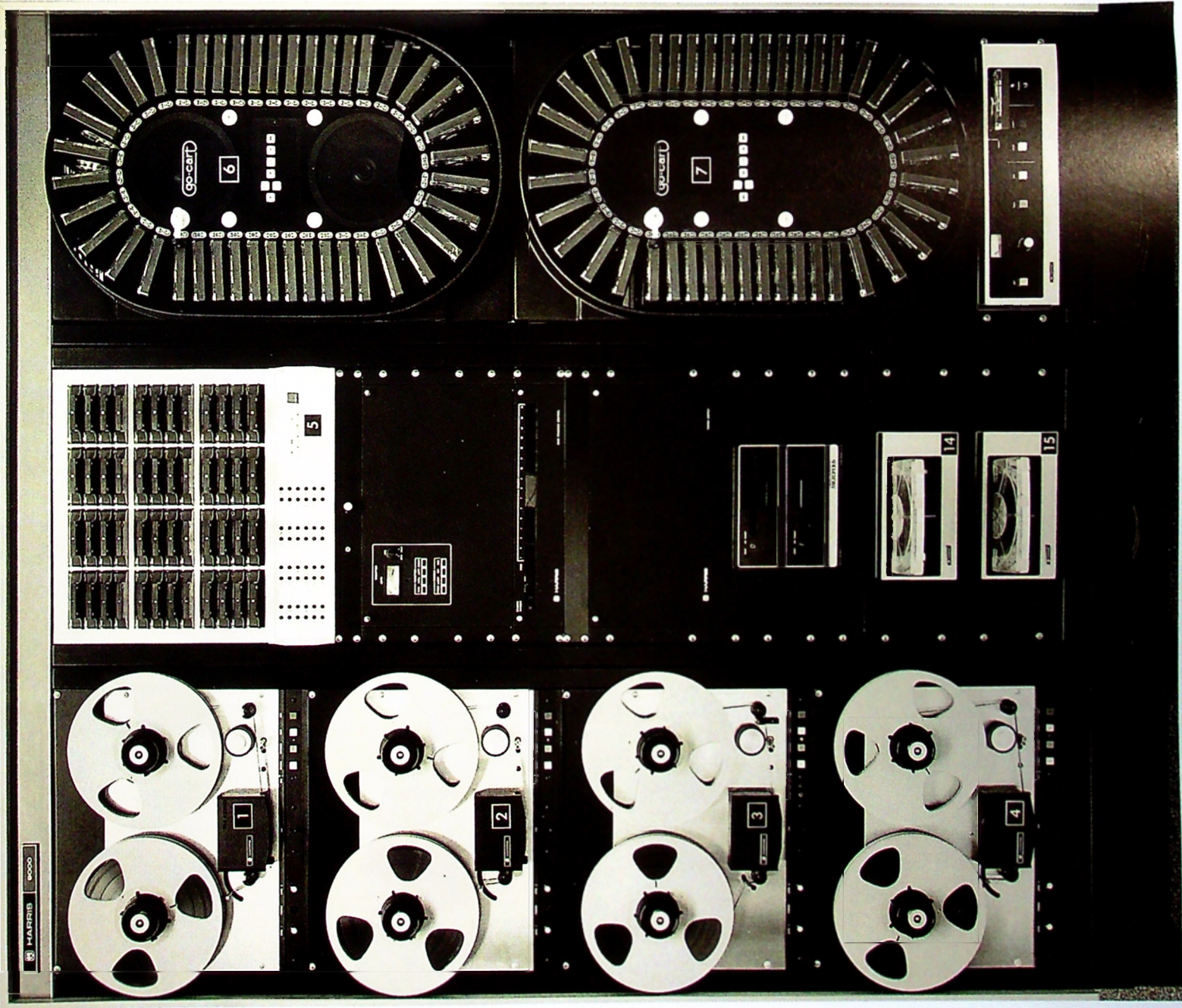

# Innovation.

*Total Digital Audio Systems Only From Harris Allied*



AUDISK DS2000



DigiLink



AAD486x



DSE 7000

 **HARRIS  
ALLIED**

800-622-0022

## GATES® SERIES

## 1, 2.5, 5 kW SOLID STATE MW TRANSMITTERS

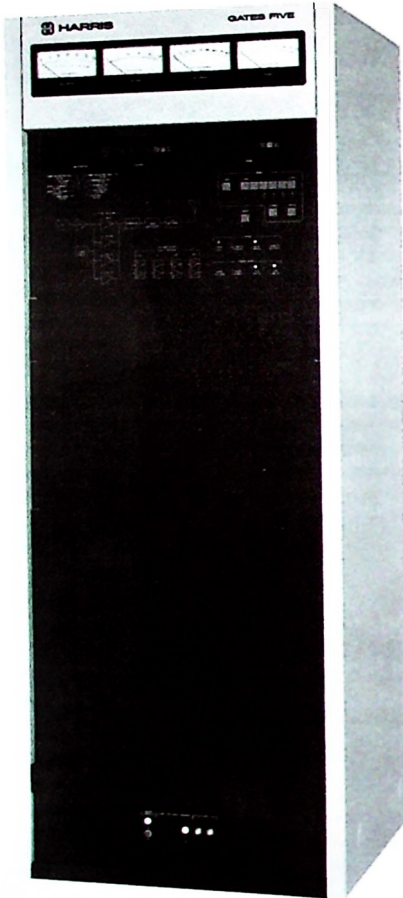

GATES FIVE

Power Levels*:		
Model	Rated Power	Power Output Range
GATES ONE	1000 W	100 W - 1100 W
GATES TWO	2500 W	250 W - 2750 W
GATES FIVE**	5000 W	500 W - 5600 W

\* Main/alternate or combined configurations available.  
\*\* Also available in frequency agile model, GATES 5A.

## KEY BENEFITS

- ▶ Harris' field-proven fourth-generation 100% solid state medium wave transmitter designed for low cost of ownership; eliminates tube replacement costs.
- ▶ Harris' patented polyphase PDM ensures outstanding performance and lowest levels of harmonic and intermodulation distortion.
- ▶ Designed for +130% peak capability and 100% continuous tone modulation.
- ▶ Standard features include built-in high-speed automatic VSWR protection with foldback for sustained VSWR conditions; constant output power and modulation tracking despite line voltage fluctuations, and six adjustable power levels.

## SPECIFICATIONS

TRANSMITTER TYPE	Medium Wave, 100% solid state.
FREQUENCY RANGE	531 - 1705 kHz.
CARRIER STABILITY	Crystal controlled oscillator meets FCC specifications. $\pm 4$ Hz in typical operating environment.
CARRIER SHIFT	Less than 1.0% at 100% modulation at 1000 Hz.
TYPE OF MODULATOR	Patented Harris Polyphase PDM.
POSITIVE PEAK CAPABILITY	Greater than +130%.
AUDIO RESPONSE	$\pm 0.5$ dB from 20 Hz to 10,000 Hz (with Bessel filter out).
AUDIO DISTORTION	Less than 1.0% at rated power, 20 Hz to 10,000 Hz at 95% modulation.
AM NOISE FIGURE	Better than 60 dB below 100% modulation.
INPUT POWER	GATES ONE, GATES TWO, GATES FIVE (Single Phase): 197 - 251 VAC, 50/60 Hz, single phase. AC voltage variation: +5, -10% for full performance. AC line protection standard, includes built-in MOV protection. GATES FIVE (Three Phase): 197 - 251 VAC, 50/60 Hz, three phase, compatible with WYE or Delta power sources or 341 to 434 VAC, 50/60 Hz, three phase, WYE. AC voltage variation: +5, -10% for full performance. Meets ANSI/IEEE C62.41-1980. AC line protection standard, includes built-in MOV protection. Single phase is available as option.
POWER CONSUMPTION	GATES ONE: At 1000 watts carrier: 1538 watts or less at 0% modulation; 2307 watts or less at 100% sine wave modulation; 1923 watts or less during typical programming. GATES TWO: At 2500 watts carrier: 3846 watts or less at 0% modulation; 5769 watts or less at 100% sine wave modulation; 4807 watts or less during typical programming. GATES FIVE: At 5000 watts carrier: 7692 watts or less at 0% modulation; 11,538 watts or less at 100% sine wave modulation; 9615 watts or less during typical programming.
SYSTEM EFFICIENCY	Typical to 72%.
STEREO CAPABLE	Yes; available with optional Harris AMS-G1 stereo exciter.
REMOTE CONTROL/MONITORING	Self-contained interface for most remote control systems; TTL compatible.
PHYSICAL DIMENSIONS	28" (71 cm) W, 30" (76 cm) D, 72" (183 cm) H.

- ▶ Provides typical overall efficiencies to 72%.
- ▶ Straightforward operation with simple discrete logic controller; extensive front panel status information; signal flow diagram for at-a-glance status assessment, and push button controls. Control circuitry adjustable from front of transmitter.
- ▶ Easy maintenance with largely modular design and socketed PA MOSFETS; exclusive "chimney design" air handling keeps transmitter cleaner than other systems.
- ▶ Self-contained interface for most remote control systems; TTL-compatible.
- ▶ Built-in full T network accommodates 1:1 matching for loads up to 1.5:1 VSWR.
- ▶ Exclusive bandpass output network provides superior phase and amplitude linearity for low distortion and minimal overshoot while protecting against lightning.
- ▶ Available with optional Harris AMS-G1 C-QUAM® stereo exciter.
- ▶ Frequency-agile GATES 5A can be tuned to any frequency in the medium wave broadcast band in less than three minutes.

## IDX SERIES DIGITALLY MODULATED

### 110, 15, 25, 50 AND 100 kW SOLID STATE MW TRANSMITTERS

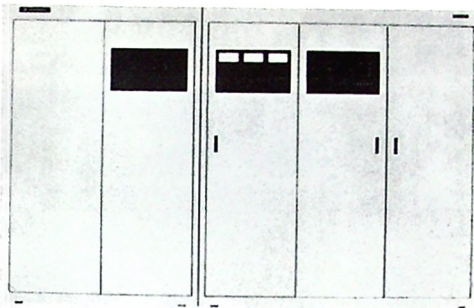

DX 50

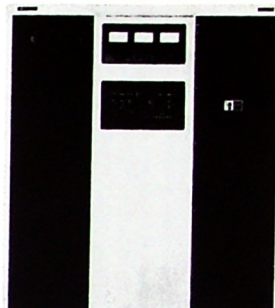

DX 10

Transmitters, AM

**Power Levels\*:**

Model	Rated Power	Power Output Range**
DX 10	10 kW	1 kW to 11 kW
DX 15	15 kW	2 kW to 15 kW
DX 25U***	25 kW	10 kW to 27.5 kW
DX 50	50 kW	10 kW to 60 kW
DX 100	100 kW	20 kW to 100 kW

\*\* DX transmitters are available in main/alternate or combined configurations.  
 \*\*\* Lower power operation possible.  
 \*\*\*\* Field upgradable to 50 kW.

### KEY BENEFITS

- ▶ Harris' patented digital amplitude modulation and all-solid state technology yield performance, efficiency and reliability unmatched in the industry.
- ▶ Typical efficiency of 85% or better reduces transmitter power consumption by up to one-third; DX transmitters practically pay for themselves in power cost savings.

### SPECIFICATIONS

TRANSMITTER TYPE	Medium Wave, 100% solid state.
FREQUENCY RANGE	531-1705 kHz.
CARRIER STABILITY	±10 Hz, 0 - 50°C, ±2 Hz at typical conditions.
CARRIER SHIFT	Less than 1.0%.
TYPE OF MODULATOR	Patented Harris AM Digital Modulation.
POSITIVE PEAK CAPABILITY	DX 10/25U/50: +145% peak; DX 15/100: ±135% peak.
DUTY CYCLE	Continuous, 100% modulated sine wave at rated power.
AUDIO RESPONSE	±0.5 dB from 20 Hz to 10 kHz.
AUDIO DISTORTION	0.9% or less at 95% modulation, 20 Hz to 10 kHz, typical 0.3%.
AM NOISE FIGURE	-65 dB or better below 100% modulation (un-weighted).
INPUT POWER	DX 10: 197-281 VAC, 3 phase, Delta or Wye, 341-468 VAC, 3 phase, Wye; optional 197-281 VAC, 1 phase, Wye. DX 15: 197-281 VAC, 3 phase, 341-468 VAC, 3 phase, Wye. DX 25U/50: Any voltage between 363 and 502 VAC, 3 phase, plus 190-240 VAC, 1 kVA, 50/60 Hz. Optional three phase only input available. DX 100: Any voltage between 363 and 502 VAC, 3 phase, plus 190-260 VAC, 1 kVA, 1 phase, 50/60 Hz. Optional three phase only input available.

- ▶ 100% solid state design totally eliminates tube replacement costs, tube inventory and associated labor expenses.
- ▶ Transparent FM-comparable audio performance with virtually no overshoot, tilt or ringing, and the lowest distortion of any transmitters.
- ▶ Audibly superior signal with ruler-flat frequency response and positive peak modulation capability of 135% or better; easily handles the most demanding formats.
- ▶ 100% continuous sine wave modulation capability at full rated power.
- ▶ Superb AM stereo performance with IQM typically -40 dB; available with optional Harris AMS-G1 C-QUAM® stereo exciter.

### POWER CONSUMPTION

### SYSTEM EFFICIENCY

### POWER FACTOR STEREO CAPABLE

### REMOTE CONTROL/MONITORING PHYSICAL DIMENSIONS

- ▶ Harris' FlexPatch™ permits operators to utilize built-in spare PA modules while transmitter continues to operate.
- ▶ Standard front-panel ColorStat™ LED signal flow diagram monitors key operating stages; facilitates troubleshooting.
- ▶ Automatic power control helps to keep power constant even with AC power line variations.
- ▶ Two-fold VSWR protection provides for short-term arcs as well as long-term sustained high VSWR; if necessary, will foldback power to keep you on the air.
- ▶ Easily accessible remote control interface panel.
- ▶ T network provides full-performance matching for less than perfect 50, j0 loads.

DX 10: 11.9 kW typical at 10 kW, 0% modulation; 17.9 kW typical at 10 kW, 100% tone modulation.
DX 15: 17.4 kW typical at 15 kW, 0% modulation; 26.2 kW typical at 15 kW, 100% tone modulation.
DX 25U: 29.4 kW or less typical at 25 kW, 0% modulation; 44.1 kW or less typical at 25 kW, 100% tone modulation.
DX 50: 59 kW or less typical at 50 kW, 0% modulation; 88 kW or less typical at 50 kW, 100% tone modulation.
DX 100: 118 kW or less typical at 100 kW, 0% modulation; 176 kW or less typical at 100 kW, 100% tone modulation.
DX 10/15: 84% or better; 86% typical.
DX 25U/50/100: 83% or better; 85% typical.
0.98% typical.
Yes; available with optional Harris AMS-G1 stereo exciter.
Self-contained remote control interface.
DX 10/15: 72" (183 cm) W, 33" (84 cm) D, 78" (198 cm) H.
DX 25U/50: 120" (305 cm) W, 33" (84 cm) D, 78" (198 cm) H.
DX 100: 156" (397 cm) W, 46" (117 cm) D, 83" (211 cm) H.

Specifications subject to change or revision.



## DX SERIES DIGITALLY MODULATED 100 AND 300 kW FREQUENCY AGILE SOLID STATE MW TRANSMITTERS

### Power Levels:

DX 100A: 100 kW  
DX 300A: 300 kW

### KEY BENEFITS

- ▶ Built-in frequency synthesizer and front panel control for tuning to any Medium Wave frequency in a matter of minutes — less than 3 minutes (30 seconds typical) for DX 100A; less than 15 minutes (5 minutes typical) for DX 300A.
- ▶ Most efficient frequency agile transmitters in the world with 83% or more typical overall operating efficiency for reduced power costs.
- ▶ High efficiency for maximum on air time due to reduced fuel consumption when powered by AC generators.
- ▶ Digital audio processing gives highest quality AM modulation for strong clear reception.
- ▶ Frequency agile ability allows you to avoid interference from other stations.
- ▶ Ruggedly built and strengthened for mobile applications — can be rapidly deployed for emergency broadcasting.
- ▶ High average and peak modulation capability permits maximum signal loudness which allows you to be heard even when subject to interference.
- ▶ Extensive front panel metering and LED status information gives you at-a-glance diagnostics for speed in maintenance.
- ▶ Modular construction allows for most repairs by module replacement if you so desire.

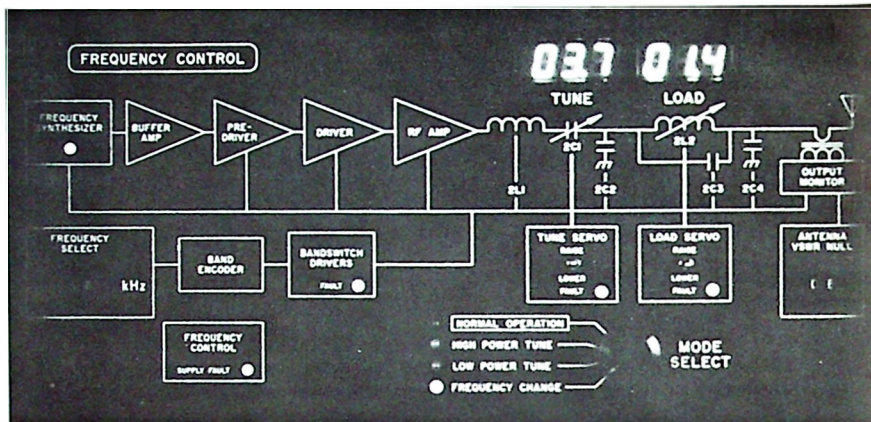

DX 100A FREQUENCY CONTROL PANEL

### TO CHANGE FREQUENCIES:

1. Select new frequency (transmitter still operating on original frequency).
2. Select frequency change.
3. Use chart to set tune, load and antenna VSWR.
4. Set to low power tune (peak tune, load for power).
5. Set to normal operation (peak power with tune, set load to proper current, null antenna VSWR).

### SPECIFICATIONS

#### GENERAL

TRANSMITTER TYPE	Medium Wave, 100% solid state.
TYPE OF MODULATION	Harris patented Digital Amplitude Modulation.
POWER OUTPUT RANGE	DX 100A: 100 kW. 3 power levels adjustable to 20% of rated power. DX 300A: 300 kW. 3 power levels adjustable to 20% of rated power.
FREQUENCY RANGE	525 kHz - 1605 kHz; (100 Hz steps).
FREQUENCY TUNING TIME	DX 100A: Full power operation between any frequency by front panel adjustment in less than 3 minutes (30 seconds typical). DX 300A: Full power operation between any frequency by front panel adjustment in less than 15 minutes (5 minutes typical).
CARRIER STABILITY	$\pm 10$ Hz, 0 to 50° C, $\pm 2$ Hz at typical conditions.
CARRIER SHIFT	Less than 1%.
AC MAINS INPUT	DX 100A: Any voltage 363 and 502 VAC, 3 phase, 50/60 Hz. DX 300A: High kV or any voltage 3 phase, specify requirements.
AC MAINS LOW VOLTAGE	DX 100A: 190-260 VAC, 1 kVA, 1 phase, 50/60 Hz. DX 300A: 190-260 VAC, 3 kVA, 1 phase, 50/60 Hz.
POWER FACTOR	0.98% typical.
OVERALL EFFICIENCY	DX 100A: 81% or better; 84% typical. DX 300A: 80% or better; 83% typical.
AUDIO RESPONSE	$\pm 0.7$ dB, 30 Hz to 10 kHz.
AUDIO DISTORTION	1.5% or less THD at 95% modulation, 50 Hz to 10 kHz (for DX 100A: 20 - 100 kW; for DX 300A: 60 - 300 kW); 0.5% typical.
AM NOISE FIGURE	-62 dB or better below 100% modulation unweighted; -68 dB typical.
POSITIVE PEAK CAPABILITY	+125%.
DUTY CYCLE	Continuous, 100% modulated sine wave at rated power.
PHYSICAL DIMENSIONS/ WEIGHT	DX 100A: 83" (211 cm) H, 156" (397 cm) W, 46" (117 cm) D max dim; 6283 lbs. (2,856 kg) approximate. DX 300A: Weight and size depend on power supply and layout requirements.

Specifications subject to change or revision.



# DX SERIES DIGITALLY MODULATED 200 - 2100 kW SOLID STATE MW TRANSMITTERS

*Power Levels\*:*

Model	Rated Power**
DX 100PB	100 kW
DX 150PB	150 kW

\* High power DX Series transmitters are configured by combining 100 or 150 kW power blocks.

\*\* Power blocks are adjustable to 20% of rated power.

## KEY BENEFITS

- ▶ Flexible DX power block architecture extends DX benefits of unsurpassed performance, efficiency and reliability to meet power requirements for any high power medium wave application.
- ▶ Virtual assurance of 100% transmitter availability with modular, redundant 100% solid state "combined power block" architecture; elimination of all single failure points, and ultra-soft-failure design.
- ▶ Mean Time Between Repairs (defined as point where transmitter output drops to 70% of rated power) exceeding 100,000 hours.
- ▶ Typical AC to RF efficiency of 83% or better; optional adaptive carrier control can reduce power consumption by an additional 35%. Transmitter practically pays for itself in reduced power costs.
- ▶ High volume production resulting from common use of medium wave power blocks reduces initial cost; enhances reliability.

## SPECIFICATIONS

### GENERAL

TRANSMITTER TYPE	Medium Wave, 100% solid state.
FREQUENCY RANGE	531 - 1605 kHz.
CARRIER STABILITY	±10 Hz, 0 - 50° C, ±2 Hz at typical conditions.
CARRIER SHIFT	Less than 1%.
TYPE OF MODULATOR	Patented Harris AM Digital Modulation.
POSITIVE PEAK CAPABILITY	DX 100PB: +135% peak; DX 150PB: +110% peak.
DUTY CYCLE	Continuous, 100% modulated sine wave at rated power.
AUDIO RESPONSE	±0.5 dB from 30 Hz to 10 kHz.
AUDIO DISTORTION	0.9% or less at 95% modulation, 30 Hz to 10 kHz, typical 0.3%.
AM NOISE FIGURE	-65 dB or better below 100% modulation (unweighted).
INPUT POWER	DX 100PB: 363 - 502 VAC, plus 190 - 260 VAC, 1 kVA, 1 phase, 50/60 Hz; DX 150PB: High voltage - specify design requirements.
POWER CONSUMPTION	DX 100PB: 118 kW or less typical at 100 kW, 0% modulation; 176 kW or less typical at 100 kW, 100% modulation; DX 150PB: 175 kW or less typical at 150 kW, 0% modulation; 262 kW or less typical at 150 kW, 100% modulation.
EFFICIENCY	DX 100PB: 83% or better, 85% typical; DX 150PB: 84% or better, 86% typical.
POWER FACTOR	0.98% typical.
STEREO CAPABLE	Yes; available with optional Harris AMS-G1 stereo exciter.
REMOTE CONTROL/ MONITORING	Self-contained remote control interface.

*Specifications subject to change or revision.*

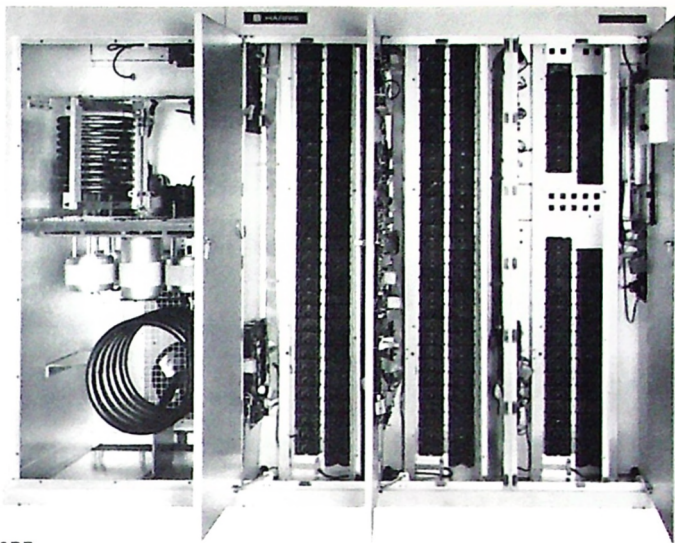

DX 100PB

- ▶ Broadband solid state design sharply reduces maintenance and eliminates complex pre-correction and tuning requirements.
- ▶ Increased safety with low voltage power amplifier circuitry.
- ▶ N-Way power block combining maintains full performance and efficiency of power blocks; easily accommodates future power upgrades; provides N-1 capability.
- ▶ Long-term durability to withstand lightning and the harshest environmental operating conditions; ruggedness verified through rigorous factory testing.
- ▶ Unmatched versatility from a modular design which allows extensive freedom in transmitter configuration; wide variety of options.
- ▶ Designed for high positive modulation capability and continuous 100% sine wave modulation, accommodating even the most demanding formats.
- ▶ Broadcaster-friendly design with extensive status information, output matching and modularity.
- ▶ Internal diagnostics in each power block facilitate troubleshooting.
- ▶ Automatic power control helps to keep power constant even with AC power line variations.
- ▶ Two-fold VSWR system protects against short-term arcs as well as long-term sustained high VSWR; will fold back power to keep you on the air.
- ▶ Easily accessible remote control interface panel.

## HIGH POWER DX TRANSMITTER OPTIONS

- ▶ **Central Control Console** with control functions and test equipment for the entire system.
- ▶ **Computerized Control** via RS232.
- ▶ **Weather-Resistant Shelters.**
- ▶ **Switching Matrix** which drives different antennas at different power levels and phases, allowing the directionality of an array to be changed quickly and easily.
- ▶ **Adaptive Carrier Control** which can reduce power consumption by an additional 35% by decreasing input power as modulation level is reduced.

## H100SW 100 kW SHORT WAVE TRANSMITTERS

## KEY BENEFITS

- ▶ Employs world's most advanced short wave technology — Harris' patented digital pulse step modulation.
- ▶ Designed for long-term value with typical overall AC line to RF conversion efficiency of 70%.
- ▶ Combines a 128 channel frequency synthesizer RF source, all-solid state 1 kW driver and single 4CM100,000A RF output tube.
- ▶ Fully automatic frequency changes — 30 seconds or less.
- ▶ Programmable for up to 16 frequency/time changes
- ▶ Extensive diagnostics — 16 bit microprocessor control and monitoring.
- ▶ Remote control via RS-422 port; compatible with RS-232.
- ▶ Engineered for reliable operation in wide variety of climates, from hot and humid to dry and dusty.
- ▶ Available with optional adaptive carrier control; optional single sideband operation.



H100SW

## SPECIFICATIONS

## GENERAL

RF FREQUENCY RANGE	3.2 to 26.1 MHz.
CARRIER STABILITY	$\pm 1 \times 10^{-7}$ per year; $5 \times 10^{-10}$ per day.
CARRIER SHIFT	<3%, 50 Hz to 10 kHz at m = 0.95.
TYPE OF MODULATION	High level plate modulation.
MODULATION PRINCIPLE	Digital Pulse Step Modulation.
MODULATION LEVEL	100% sinusoidal, 10 minutes, 500 Hz to 5 kHz.
PEAK MODULATION	+120% on positive peaks, asymmetrical modulation.
AUDIO FREQUENCY RESPONSE	$\pm 1$ dB, 40 Hz to 10 kHz; $\pm 0.5$ dB, 100 Hz to 5 kHz at m = 0.95.
AUDIO DISTORTION	<3%, 50 Hz to 10 kHz at m = 0.95.
AM NOISE	55 dB below 400 Hz, 100% modulation, unweighted..
TUBE	One 4CM100,000A.
INPUT POWER	380 V to 480 V, three phase, 50/60 Hz. Phase unbalance <5%; regulation +5%, -10%.
POWER CONSUMPTION	100 kW carrier: <150 kW; 30% modulation; <154 kW; 100% modulation; <214 kW.
POWER FACTOR	cos $\phi$ >0.95.
PHYSICAL DIMENSIONS	Cabinet: 405 cm W, 176.6 cm D, 204.2 cm H. Plus heat exchanger: 147 cm W, 91 cm D, 112 cm H.

NOTES: Tests are made into a dummy load. Specifications subject to change without notice.

DIGIT™ 1 - 55 W DIGITAL FM EXCITER

Transmitters, FM

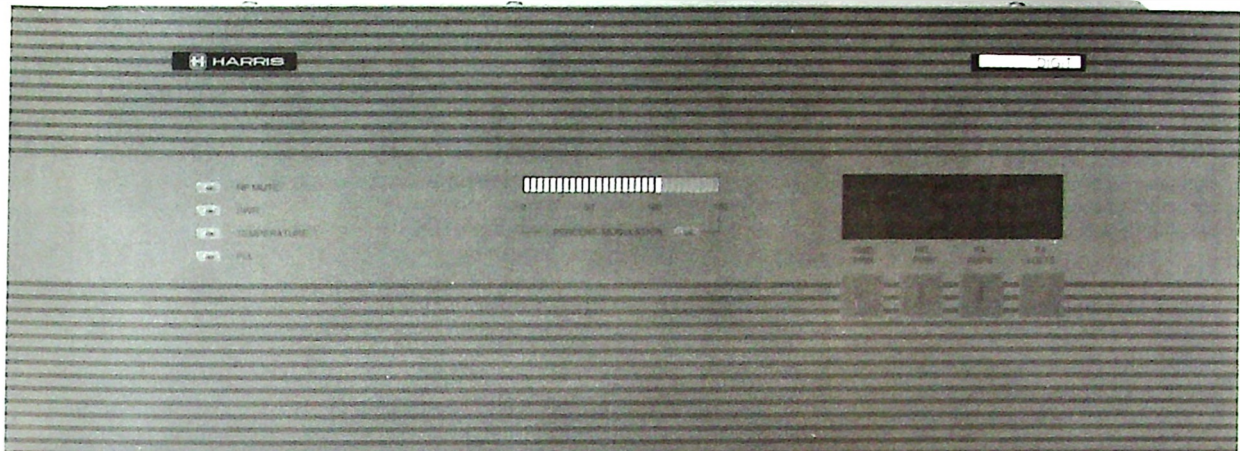

DIGIT

KEY BENEFITS

- ▶ True digital audio quality; matches or exceeds most digital program sources.
- ▶ Direct digital synthesis (DDS) of the modulated FM carrier from a digital input signal (500 kHz nominal data rate), using a 32-bit DDS chip.
- ▶ Uses either an AES/EBU interface or an analog interface module (mounts to/powerd by exciter, one required).
- ▶ Unlike analog exciters, provides sustainable performance that is not subject to degeneration over time.
- ▶ Typical signal-noise ratio >96 dB (de-emphasised, A-weighted).
- ▶ Superb wideband amplitude response ( $\pm 0.01$  dB) and phase linearity ( $\pm 0.01$  degrees) for audibly transparent passage of stereo baseband.
- ▶ Precise composite modulation metering as derived from digital data.
- ▶ Quick-start; <0.5 second typical recovery from loss of AC power.
- ▶ Frequency agile, broadband design; no tuning required from 87.5 to 108 MHz.
- ▶ Modulation sensitivity unaffected by carrier frequency; no gain adjustments needed.
- ▶ Remote carrier frequency selection available using optional "N+1" external controller.
- ▶ Stable, drift-free performance characteristics.
- ▶ High immunity to microphonics and mechanically-induced noise.
- ▶ Meets IEEE 587 performance standard for suppression of voltage transients.
- ▶ FCC/DOC accepted as stand-alone FM transmitter when used with optional harmonic filter.

SPECIFICATIONS

<b>GENERAL</b>		<b>START-UP TIME</b>	<1.0 second typical.
<b>POWER OUTPUT</b>	1 - 55 Watts.	<b>RUGGEDNESS</b>	IEC 587.
<b>RF OUTPUT IMPEDANCE</b>	BNC, 50 ohms, fully VSWR protected (automatic foldback).	<b>STANDARD WIDEBAND COMPOSITE OPERATION</b>	
<b>FREQUENCY STABILITY</b>	$\pm 500$ Hz; $\pm 300$ Hz typical.	<b>FM SIGNAL TO NOISE</b>	16 bit quantization (96 dB) below $\pm 75$ kHz deviation at 400 Hz. Measured in a DC to 100 kHz bandwidth with a 75 microsecond de-emphasis. DIN "A" weighting does not exhibit the subsonic noise associated with analog exciters.
<b>MODULATION CAPABILITY</b>	150%, reference 75 kHz.	<b>THD</b>	16 bit linearity (96 dB or 0.016% THD) at 400 Hz.
<b>AC POWER INPUT</b>	90 - 132 VAC or 198 to 264 VAC, 50/60 Hz, 1-phase.	<b>SYNCHRONOUS AM</b>	64 dB minimum.
<b>PHYSICAL DIMENSIONS</b>	19" (48.26 cm) W, 12.5" (31.75 cm) D, 7" (17.78 cm) H.	<b>ASYNCHRONOUS AM</b>	80 dB typical.
<b>WEIGHT</b>	Approximately 35 lbs. (15.9 kg).	<b>STEREO OPERATION<sup>1</sup></b>	
<b>RF HARMONICS/SPURIOUS OUTPUT SUPPRESSION</b>	Meets or exceeds FCC/DOC/CCIR specifications.	<b>STEREO SEPARATION</b>	65 dB, >75 dB typical, 30 Hz to 15 kHz. Fixed frequency only.

<sup>1</sup> Laboratory grade generators/demodulators.

Specifications subject to change or revision.



## THE-1 3 - 55 W SOLID STATE FM EXCITER

## KEY BENEFITS

- ▶ Harris' fifth generation solid state FM exciter.
- ▶ Designed for retrofit in any FM transmitter or for stand-alone operation as a low power FM transmitter.
- ▶ Ultra-linear voltage controlled oscillator offers superb linearity for virtually transparent passage of stereo and multiple subcarriers.
- ▶ Typical FM noise -87 dB or better.
- ▶ Typical harmonic distortion 0.025% or better (400 Hz, de-emphasized).
- ▶ Audio performance approaches the best digital program source material and far exceeds most analog STLs and telco program links.
- ▶ Modular design and conveniently located controls simplify adjustment and servicing. The broadband output amplifier requires no tuning.
- ▶ Comprehensive metering, status and control functions, including separate LED indicators for AC power, AFC lock, RF mute, cooling faults, and output power.
- ▶ Slide-out drawer construction with balanced plug-in modules and subassemblies. Internal adjustments easily accessible.
- ▶ Other standard features include balanced monaural input with selectable pre-emphasis, front-panel composite test input/output jacks, built-in remote control interface, two composite baseband inputs, and two SCA inputs.

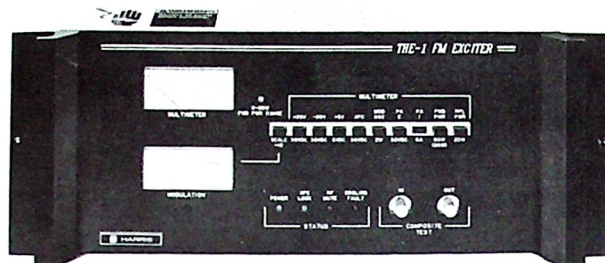

THE-1

## SPECIFICATIONS

## GENERAL

POWER OUTPUT	3 to 55 watts or 3 to 15 watts, continuously variable. Output power range user-selectable.
RF OUTPUT IMPEDANCE	50 ohms, fully VSWR protected (automatic foldback).
FREQUENCY STABILITY	$\pm 300$ Hz $0^{\circ}$ to $50^{\circ}$ C temperature-compensated oscillator.
MODULATION CAPABILITY	$\pm 200$ kHz.
AC INPUT POWER	90 to 132 VAC or 198 to 264 VAC, 50/60 Hz, 1-phase; 275 watts (typical) at 55 watts RF output.
PHYSICAL DIMENSIONS	19" (48.26 cm) W, 12.5" (31.75 cm) D, 7" (17.78 cm) H; EIA rack mounting standard including rack slides and mounting tray.
WEIGHT	47 lbs. (21.4 kg).
STANDARD WIDEBAND COMPOSITE OPERATION	
AMPLITUDE RESPONSE	$\pm 0.1$ dB, 30 Hz to 53 kHz; down -0.2 dB at 100 kHz (typical).
FM SIGNAL TO NOISE	80 dB, typically $\geq 85$ dB, below 100% modulation typical (ref. 400 Hz at +75 kHz deviation with 75 microsecond de-emphasis, 20 Hz to 200 kHz bandwidth).
HARMONIC DISTORTION	0.05%, typically $\geq 0.01\%$ , at 400 Hz, de-emphasized.
INTERMODULATION DISTORTION	0.02% (60 Hz/7 kHz 1:1 tone pair).
CCIF INTERMODULATION DISTORTION	All distortion products below 80 dB (ref. 14 kHz/15 kHz tone test pair).
ASYNCHRONOUS AM	55 dB below equivalent 100% amplitude modulation. Typically 77 dB or better.
SYNCHRONOUS AM	55 dB below equivalent 100% amplitude modulation of 15 to 55 watt output carrier with 75 microsecond de-emphasis (FM modulation $\pm 75$ kHz @ 400 Hz).
STEREO OPERATION <sup>1</sup>	
STEREO SEPARATION	50 dB, 30 Hz to 15 kHz; 60 dB at midband frequencies typical.
NONLINEAR CROSSTALK	-60 dB.

<sup>1</sup>Typical performance with high quality stereo/SCA generators and demodulators (not supplied).

## QEI

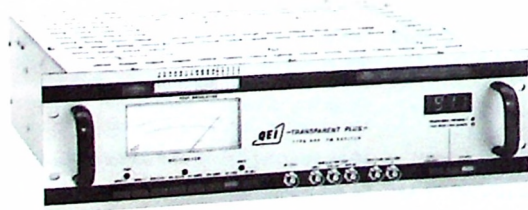

## 695 FM EXCITER

The 695 is QEI's advanced technology FM exciter with more features and better performance than heretofore available. It is designed for unparalleled transparency in the transformation of program material to an FM signal. Noise and distortion of all kinds are reduced to a point where they become difficult to measure.

## BEXT



## TEX 20 FM EXCITER

The TEX 20 provides 2 to 20 kW of power. Like all Bext exciters, it is front-panel frequency agile; remote controllable; modular for easy servicing; compatible with external references for synchronization, and has three SCA inputs and state-of-the-art audio circuitry for improved THD and S/N figures. Bext offers six power levels of exciters up to 100 watts, translators, boosters, transmitters to 30 kW, and frequency-agile STLs.

QUEST™

100 - 1,000 W SOLID STATE FM TRANSMITTERS

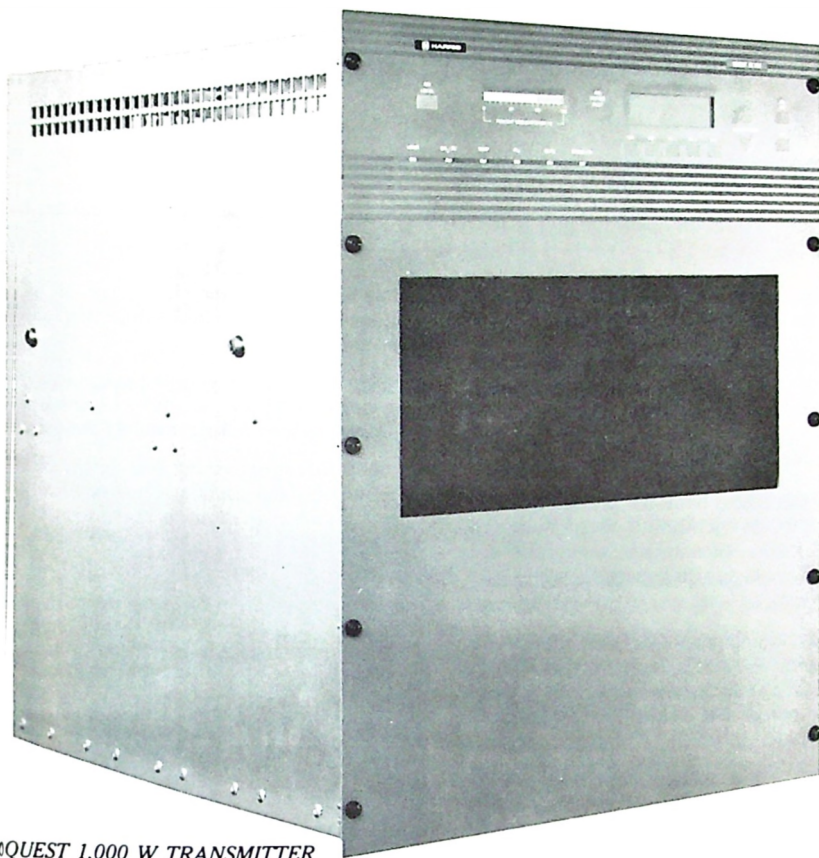

QUEST 1,000 W TRANSMITTER

**SPECIFICATIONS**

GENERAL

FREQUENCY RANGE	87.5 to 108 MHz in 10 kHz steps.
EXCITER	Self-contained 10 W exciter.
MAXIMUM VSWR	1.5:1 VSWR, maximum for full output power; automatic power reduction into higher VSWR.
FREQUENCY STABILITY	±3 ppm, 0° C to 50° C.
RF LOAD IMPEDANCE	50 ohms; fully VSWR protected.
RF HARMONIC/SPURIOUS OUTPUT	Suppression meets or exceeds FCC/DOC/CCIR specifications.
AC INPUT POWER	120 VAC at 60 Hz, 208/220/240 VAC at 50/60 Hz, single phase, 2-wire, +10/-15% line variation.
PHYSICAL DIMENSIONS	24.5" (62.23 cm) H, 22.2" (56.38 cm) D, 19" (48.26 cm) W; 19-inch rack-compatible.
WEIGHT	235 lbs. (106.8 kg).
STANDARD WIDEBAND COMPOSITE OPERATION	
FM SIGNAL TO NOISE	78 dB below 400 Hz, reference @ ±75 kHz deviation with 75 microsecond de-emphasis, 22 Hz to 500 kHz bandwidth.
HARMONIC DISTORTION	0.02%, 30 Hz to 100 kHz, 75 microsecond de-emphasis.
INTREMULATION DISTORTION	0.03% (60 Hz/7 kHz 1:1 tone pair)
CCIF INTERMODULATION DISTORTION	All distortion products below 74 dB (reference 14 kHz/15 kHz test tone pair).
ASYNCHRONOUS AM NOISE	-55 dB below equivalent 100% amplitude modulation.
SYNCHRONOUS AM NOISE	-60 dB below equivalent 100% amplitude modulation with 75 microsecond de-emphasis. (FM modulation ±75 kHz at 1 kHz).

Specifications subject to change or revision.



Power Levels\*

Model	Nominal Power
Quest 100W	100 W
Quest 250W	250 W
Quest 500W	500 W
Quest 1 kW	1,000 W

\*Available in optional main/alternate configurations.

**KEY BENEFITS**

- ▶ Cost effective, all-solid state design.
- ▶ Broadband system; any assigned carrier frequency 87.5 to 108MHz (10kHz steps) with simple VOM-assisted adjustments.
- ▶ Integrated 10 watt exciter with direct carrier FM; compatible with external stereo, SCA and RDS generators.
- ▶ Built-in monaural input with selectable pre-emphasis.
- ▶ Simple front-panel control and monitoring.
- ▶ Automatic power control.
- ▶ Standard VSWR overload protection, VSWR foldback, AC/DC overload protection.
- ▶ Remote control interface compatible with many open collector remote control systems (no relay panel needed).
- ▶ Built-in harmonic filter, directional coupler and RF sample port.
- ▶ Ferroresonant power supply to maintain nominal output power with +10 to -15% AC mains voltage variation (dual 600 W supplies in 1 kW transmitters).
- ▶ Compact design for mount in customer-supplied 19" EIA rack (24.5" H x 19" W x 22.2" D).

Transmitters, FM

HT 250/500/1FM

250, 500, 1,000 W SOLID STATE FM TRANSMITTERS

Transmitters, FM

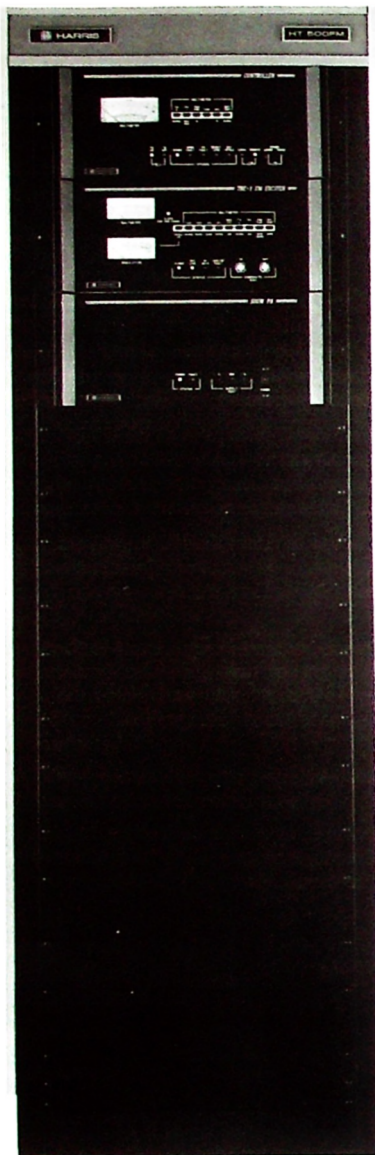

HT 500FM

Power Levels*		
Model	Nominal Power	Power Output Range
HT 250FM	250 W	55 W - 265 W**
HT 500FM	500 W	235 W - 525 W**
HT 1FM	1,000 W	475 W - 1050 W

\* Main/alternate and combined configurations available with automatic switchover.  
 \*\* Field expandable to 1000 watts.

KEY BENEFITS

- ▶ 100% solid state transmitters replace tubes with FET RF amplifiers.
- ▶ Integrated RF amplifier modules— each with their own AC power supply and cooling— offer long life and require no tuning or adjustment to produce full rated power from 87.5 - 108 MHz.
- ▶ Each amplifier block self-protected for AC and DC overloads and open or shorted RF loads. RF amplifier assemblies are field-proven, with hundreds currently in service.
- ▶ Each amplifier block will operate independently outside of the transmitter, enabling maintenance on any block while the rest of the transmitter continues to operate.
- ▶ THE-1 FM exciter standard. FLEX-Patch™ emergency RF patching allows the exciter or any of the amplifiers to be easily patched to the transmitter's output connector.
- ▶ Designed for easy installation and service, these transmitters feature slide-out subassemblies.
- ▶ Standard features include automatic power control, proportional VSWR

- foldback, auto-restart in event of AC failure, comprehensive monitoring, and remote control interface.
- ▶ Ideal for booster or stand-by service.
- ▶ Containerized 500 W model available.

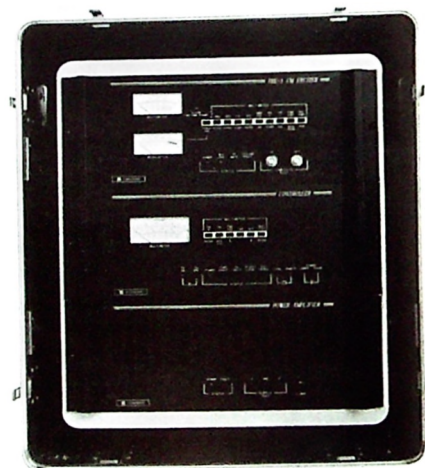

CONTAINERIZED HT 500FM

SPECIFICATIONS

GENERAL

FREQUENCY RANGE	87.5 to 108 MHz in 50 kHz steps.
TYPE OF MODULATION	Direct carrier frequency modulation (DCFM).
MODULATION CAPABILITY	±200 kHz.
RF LOAD IMPEDANCE	50 ohms.
MAXIMUM LOAD VSWR	1.5:1 VSWR, maximum for full output power; automatic power reduction into high VSWRs.
RF HARMONIC/SPURIOUS OUTPUT	Suppression meets or exceeds FCC/DOC/CCIR specifications.
AC INPUT POWER	197 - 250 VAC, 50 or 60 Hz, single phase, 2-wire.
POWER CONSUMPTION (Nominal)	
HT 250FM:	700 watts.
HT 500FM:	1450 watts.
HT 1FM:	2900 watts.
PHYSICAL DIMENSIONS	22 1/8" (56.2 cm) W, 25 1/2" (64.8 cm) D, 72" (182.9 cm) H.
WEIGHT	HT 250FM: 185 lbs. (84 kg); HT 500FM: 275 lbs. (125 kg); HT 1FM: 400 lbs. (181 kg).
PERFORMANCE	Transparent to exciter.

## PLATINUM SERIES®

### 2, 4, 5, 8, 10 kW SOLID STATE FM TRANSMITTERS

*Power Levels\*:*

Model	Nominal Power	Power Output Range
PT 2FM	2 kW	1,000 - 2,200 W
PT 4FM	4 kW	2,000 - 4,400 W
PT 5FM	5 kW	2,500 - 5,500 W
PT 8FM	8 kW	4,000 - 8,800 W
PT 10FM	10 kW	5,000 - 11,000 W

\* Platinum Series FM Transmitters are available in main/alternate or combined configurations.

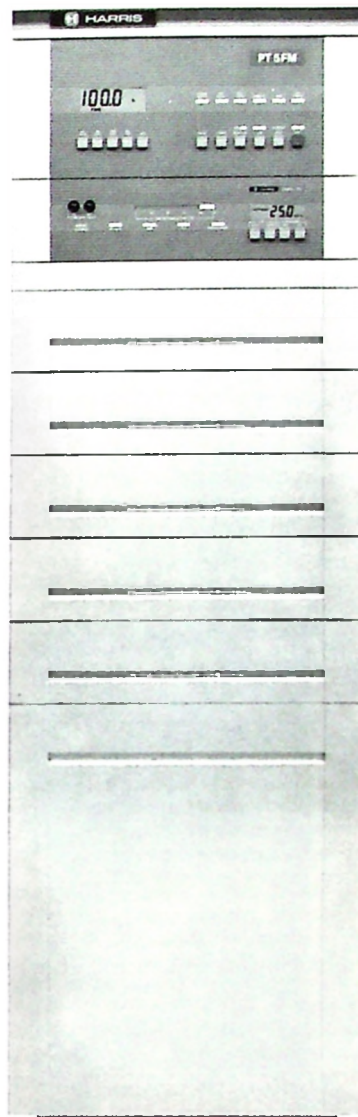

PT 5FM

Transmitters, FM

### KEY BENEFITS

- ▶ 100% solid state architecture eliminates single failure point of tube designs for reliable operation without a standby transmitter.
- ▶ Identical and interchangeable solid state power amplifiers, fans and other components operate in parallel for added reliability.
- ▶ Rugged FET (Field Effect Transistor) RF power amplifier modules are designed to deliver rated power despite environmental extremes.
- ▶ Built-in protection against high VSWR, power line variations and other conditions.
- ▶ Dual transmitters available with Harris' Switchless FM Combining System for twice the output power and continuous transmission of signals when changing from dual to single transmitter configuration.
- ▶ Straightforward controls and monitoring allow operation by non-technical personnel.
- ▶ Absolutely no tuning, loading, matching or other complex adjustments associated with tube technology required.
- ▶ Designed for easy maintenance and servicing during on-air operation.
- ▶ Safe low-voltage circuitry complies with all IEC 215 requirements for personnel safety.
- ▶ Wideband design eliminates all tuning through the 87.5 - 108 MHz band.
- ▶ Uncompromised bandwidth ensures superb signal quality, minimum group delay variation, and lowest incidental (synchronous) AM.
- ▶ Clean output spectrum: harmonics/spurious 100 dB or more below carrier.
- ▶ Designed to maintain outstanding performance under any combination of operating extremes.
- ▶ Available with Harris' THE-1 solid state FM exciter or the revolutionary Digit™ exciter for CD-like quality and optional N+1 capability.

### SPECIFICATIONS

#### GENERAL

FREQUENCY RANGE	87.5 to 108 MHz.
RF LOAD IMPEDANCE	50 ohms.
MAXIMUM LOAD VSWR	1.35:1 VSWR, maximum for full output power; automatic power reduction into high VSWRs.
AC INPUT POWER	197-250 VAC, 50 or 60 Hz, 3 phase, 3-wire, 380-415 VAC, 50 or 60 Hz, 3 phase, 4-wire, or 197-250 VAC, 60 Hz only, single phase, 2 or 3-wire.
POWER CONSUMPTION (Typical) (Three Phase operation)	PT 2FM: 3300 watts (4.4 kVA) PT 4FM: 6600 watts (8.8 kVA). PT 5FM: 8300 watts (11.1 kVA). PT 8FM: 13,300 W (17.8 kVA). PT 10FM: 16,600 W (22.1 kVA).
PHYSICAL DIMENSIONS	PT 2/4/5FM: 23½" (59.7 cm) W, 38¼" (97.2 cm) D, 72" (182.9 cm) H. PT 8/10FM: 47" (119.4 cm) W, 38¼" (97.2 cm) D, 89" (226 cm) H.
WEIGHT	PT 2FM: 1050 lbs. (477.27 kg). PT 4FM: 1150 lbs. (522.72 kg). PT 5FM: 1200 lbs. (545.45 kg). PT 8FM: 2700 lbs. (1227 kg). PT 10FM: 2800 lbs. (1273 kg).
PERFORMANCE	Transparent to exciter.

Specifications subject to change or revision.

**HT 3.5/5/7/10FM**  
**3.5, 5, 7, 10 kW FM TRANSMITTERS**

Power Levels*:		
Model	Nominal Power	Power Output Range
HT 3.5FM	4 kW	800 W - 4 kW
HT 5FM	5 kW	1.5 - 5.5 kW
HT 7FM	7 kW	3 - 8 kW
HT 10FM	10 kW	5 - 11 kW

\* HT FM transmitters are available in main/alternate or combined configurations.

**KEY BENEFITS**

- ▶ Features single tube design with a long-life, high efficiency tetrode operating in a wideband, quarter-wave cavity.
- ▶ Single phase power on the HT 3.5FM and HT 5FM; HT 7FM and HT 10FM available in three phase or single phase models.
- ▶ Can be configured with digital FM exciter with AESE-EBU or analog inputs or traditional analog exciter.
- ▶ RF patch-around capability provides continued on-air operation at reduced power in emergencies.
- ▶ Front-panel block diagram facilitates monitoring; LED indicators show circuit status in each major functional stage and have fault memory in case of power failure.
- ▶ Modular design ensures easy access during maintenance.
- ▶ Standard features include automatic AC re-start, automatic power control, proportional VSWR foldback and full remote control interface.
- ▶ Compact transmitter requires minimal floor space.

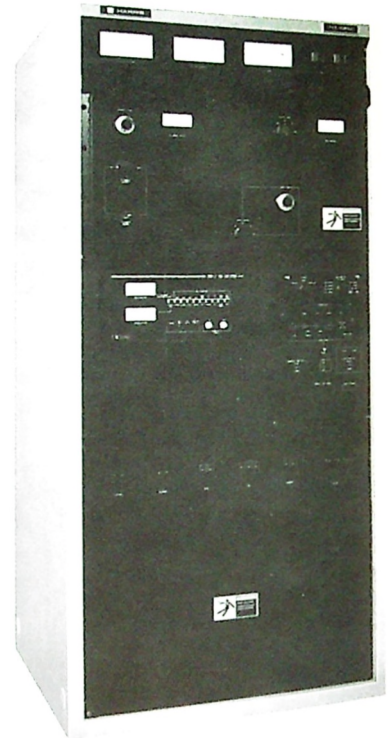

HT 10FM



HT 3.5FM

**SPECIFICATIONS**

**GENERAL**

- FREQUENCY RANGE: 87.5 to 108 MHz in 50 kHz steps. Tuned to single frequency.
- TYPE OF MODULATION: Direct carrier frequency modulation (DCFM).
- MODULATION CAPABILITY: ±200 kHz.
- RF LOAD IMPEDANCE: 50 ohms.
- PA MATCHING RANGE: HT 3.5/5FM: 2:1 VSWR, maximum for full output power; automatic power reduction into high VSWRs. HT 7/10FM: 1:7 VSWR, maximum for full output power; automatic power reduction into high VSWRs.
- AC INPUT POWER: HT 3.5/5 FM: 197-251 VAC, 50/60 Hz, 1 phase, 2-wire. HT 7FM: 197-251 VAC, 50/60 Hz, 1 phase, 2-wire. Optional: 197-250 VAC, 50/60 Hz, 3 phase, 3-wire closed delta or WYE or 360-415 VAC 4-wire WYE. HT 10FM: 197-250 VAC, 50/60 Hz, 3 phase, 3-wire closed delta or WYE or 360-415 VAC 4-wire WYE. Optional: 197-251 VAC, 50/60 Hz, 1 phase, 2-wire.
- POWER CONSUMPTION: HT 3.5FM: 7.5 kW typical at 4 kW RF output. HT 5FM: 8.9 kW typical at 5 kW RF output. HT 7FM: 13.5 kW typical at 8 kW output. HT 10FM: 15.7 kW typical at 10 kW output.
- AIR REQUIREMENTS: 400 CFM at 60 Hz; 350 CFM at 50 Hz. No back pressure.
- PHYSICAL DIMENSIONS: 33" (84 cm) W, 34" (99 cm) D, 72" (183 cm) H.
- WEIGHT: HT 3.5FM: 880 lbs. (400 kg); HT 5FM: 1025 lbs. (466 kg); HT 7FM: 1050 lbs. (477 kg); HT 10FM: 1125 lbs. (511 kg).
- PERFORMANCE: Transparent to exciter.



**HT 20/25FM**  
**20 AND 25 kW FM TRANSMITTERS**

Transmitters, FM

Power Levels*:		
Model	Nominal Power	Power Output Range
HT 20FM	20 kW	8 - 21.5 kW
HT 25FM	25 kW	8 - 27 kW

\* HT FM transmitters are available in main/alternate or combined configurations.

**KEY BENEFITS**

- ▶ Quarter-wave PA cavity for lowest synchronous AM and best stereo and SCA performance.
- ▶ Typical PA efficiency greater than 77%.
- ▶ Can be configured with digital FM exciter with AES-EBU or analog inputs or traditional analog exciter.
- ▶ Highly efficient low-noise cooling system for quiet operation.
- ▶ Single rugged long-life tetrode for low-cost ownership. High plate dissipation rating (20 kW) offers more reserve capability than competitive design.
- ▶ FlexPatch™ capability permits the preamplifier, IPA or even the PA to be bypassed for continued operation during an emergency.
- ▶ Other standard features include proportional VSWR foldback, automatic AC restart, automatic power control and remote control interface.
- ▶ Features stand-alone power supply.
- ▶ For dual combined transmitters, automatic output switching and automatic exciter switching are available.

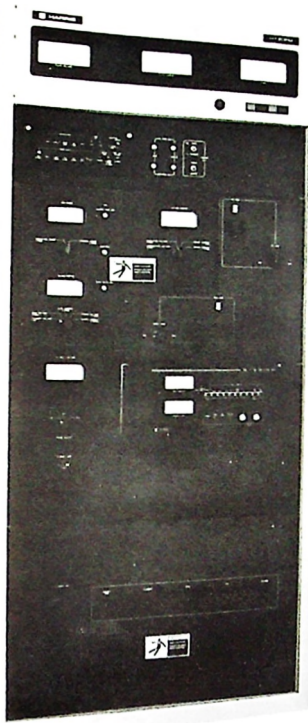

HT 20FM



HT 25FM

**SPECIFICATIONS**

GENERAL	
FREQUENCY RANGE	87.5 to 108 MHz in 50 kHz steps. Tuned to single frequency.
TYPE OF MODULATION	Direct carrier frequency modulation (DCFM).
MODULATION CAPABILITY	±200 kHz.
RF LOAD IMPEDANCE	50 ohms.
PA MATCHING RANGE	1:7 VSWR, maximum for full output power; automatic power reduction into high VSWRs.
AC INPUT POWER	197-250 VAC, 50/60 Hz, three phase, 3-wire closed delta or WYE or 360-415 VAC 4-wire WYE.
POWER CONSUMPTION	HT 20FM: 30.8 kW typical at 20 kW RF output (0.95 PF). HT 25FM: 37.5 kW typical at 25 kW RF output (0.95 PF).
AIR REQUIREMENTS	Main Cabinet: 760 CFM at 60 Hz; 710 CFM at 50 Hz. Power Supply: 250 CFM at 60 Hz, 200 CFM at 50 Hz at zero back pressure.
PHYSICAL DIMENSIONS	33.4" (85 cm) W, 30.2" (77 cm) D, 72" (183 cm) H. Power Supply: 48" (122 cm) W, 24.1" (61 cm) D, 60.25" (153 cm) H.
WEIGHT	HT 20FM: 2550 lbs. (1159 kg); HT 25FM: 2700 lbs. (1227 kg).
PERFORMANCE	Transparent to exciter.

Specifications subject to change or revision.

**HT 30/35FM**  
**30 AND 35 kW FM TRANSMITTERS**

Transmitters, FM

Power Levels*:		
Model	Nominal Power	Power Output Range
HT 30FM	30 kW	10 - 31.5 kW
HT 35FM	35 kW	10 - 37 kW

\* HT FM transmitters are available in main/alternate or combined configurations.

**KEY BENEFITS**

- ▶ Quarter-wave cavity for the best stereo and SCA performance and lowest synchronous AM.
- ▶ PA stage efficiency is 80% nominal for reduced operating costs and long tube life.
- ▶ Can be configured with digital FM exciter with AES-EBU or analog inputs or traditional analog exciter.
- ▶ High efficiency low-noise blower for ample cooling to 10,000-foot altitudes.
- ▶ Advanced microprocessor-based main controller works in parallel with a discrete logic back-up controller.
- ▶ Built-in FlexPatch™ capability permits the preamplifier, the IPA or even the final PA to be bypassed for continued operation at reduced power in emergency conditions.
- ▶ ColorStat™ front panel signal flow diagram provides at-a-glance status information.
- ▶ Automatic logging of date and time for seven major overloads, assisting with problem isolation.
- ▶ Standard features also include automatic AC re-start, automatic power control, proportional VSWR foldback, and interface for remote or extended control.
- ▶ Features stand-alone power supply.
- ▶ For dual combined transmitters, automatic output switching and automatic exciter switching are available.

**SPECIFICATIONS**

**GENERAL**

FREQUENCY RANGE	87.5 to 108 MHz in 50 kHz steps. Tuned to single frequency.
TYPE OF MODULATION	Direct carrier frequency modulation (DCFM).
MODULATION CAPABILITY	±200 kHz.
RF LOAD IMPEDANCE	50 ohms.
PA MATCHING RANGE	1:7 VSWR, maximum for full output power; automatic power reduction into high VSWRs.
AC INPUT POWER	197-250 VAC, 50/60 Hz, three phase, 3-wire closed delta or WYE or 360-415 VAC 4-wire WYE; phases to be balanced within 3%.
POWER CONSUMPTION	HT 30FM: 46 kW typical at 30 kW RF output (0.95 PF). HT 35FM: 52 kW typical at 35 kW RF output (0.95 PF).
AIR REQUIREMENTS	Main Cabinet: 1185 CFM at 60 Hz; 1130 CFM at 50 Hz. Power Supply: 250 CFM at 60 Hz, 200 CFM at 50 Hz at zero back pressure.
PHYSICAL DIMENSIONS	33.5" (85 cm) W, 33.5" (85 cm) D, 72" (183 cm) H; Power Supply: 52" (132 cm) W, 26" (66 cm) D, 52" (132 cm) H.
WEIGHT	HT 30FM: 2850 lbs. (1295 kg); HT 35FM: 2900 lbs. (1318 kg).
PERFORMANCE	Transparent to exciter.

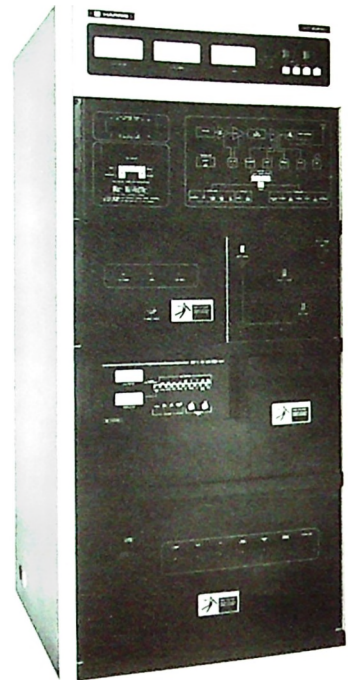

HT 30FM

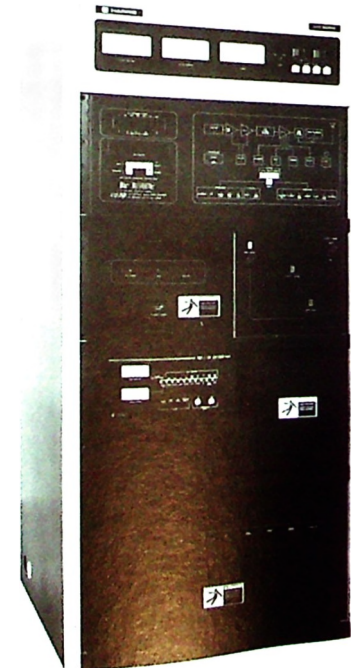

HT 35FM

Specifications subject to change or revision.

 **HARRIS  
ALLIED**  
BROADCAST EQUIPMENT



## TAKING THE LEAD IN TECHNOLOGY

Harris Allied is leading broadcasting into the future with advanced technology that dramatically increases reliability and simplicity, improves performance, and reduces power costs. Among exciting RF innovations are Platinum Series™ all solid state VHF TV transmitters, which provide unsurpassed on-air reliability and require only 10% the routine maintenance of tube transmitters, and DX Series medium wave transmitters which use patented digital modulation to cut transmitter power costs by up to a third and provide near-perfect performance. Shown here are modules from each.

## HX IV VHF VISUAL/AURAL EXCITER

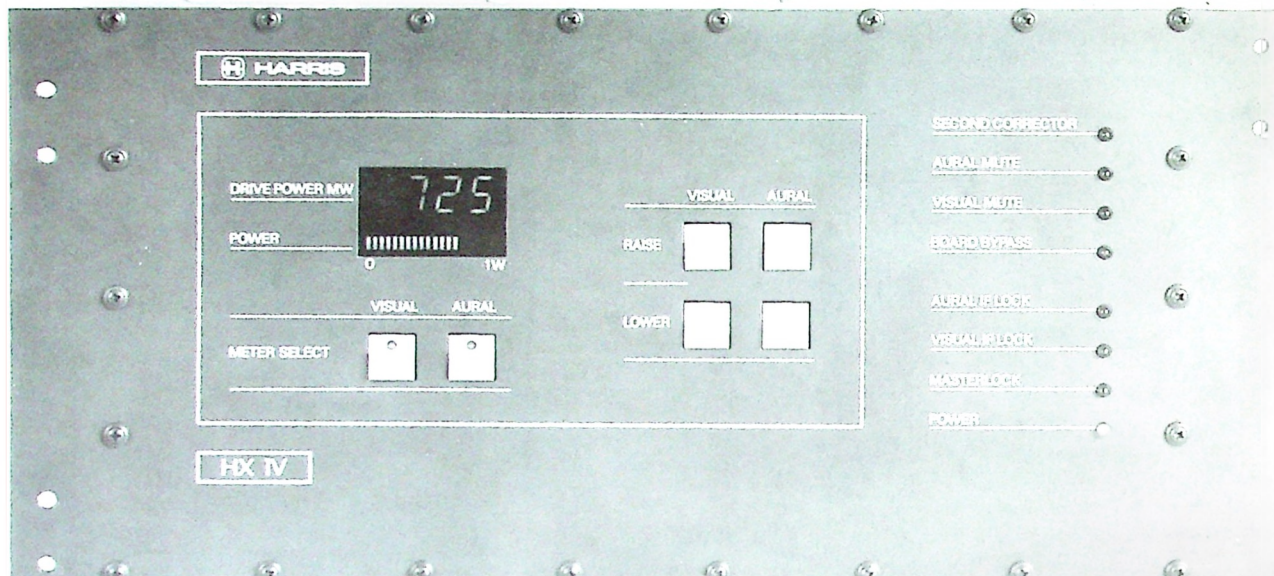

HX IV

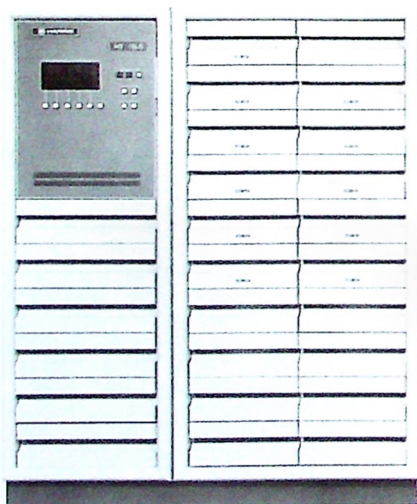

HT 5LS

## KEY BENEFITS

- ▶ Extensive built-in transmitter pre-correction circuitry facilitates transmitter set-up and provides stable operation.
- ▶ Enhanced reliability with 100% solid state design and fewer parts than previous generation VHF exciters.
- ▶ User-friendly Harris SAW filter with built-in receiver group delay function for System M or System B reduces maintenance adjustments.
- ▶ Single temperature-controlled crystal oscillator and PLL circuitry develops all required frequencies, including offsets of  $\pm 10$  kHz, or precision offsets of the horizontal line frequency.
- ▶ Full capability for remote control operation.
- ▶ Automatic circuit control mutes exciter if video is removed; keeps track of the status change, and prevents the transmitter from running at full carrier power.
- ▶ "Slide-out drawer" 19-inch rack-mount exciter contains all video, audio, IF, RF boards and power supply; common package for visual and aural exciter circuits simplifies interconnects.
- ▶ Space for an optional notch diplexer equalizer, receiver equalizer and a stereo aural group delay corrector.
- ▶ Typical audio performance equivalent to high quality FM broadcast transmitter.
- ▶ Long-life front-panel LEDs provide at-a-glance status information.
- ▶ Can be used as 1 watt transmitter with addition of filtering.
- ▶ Available with Precise Frequency Control.
- ▶ NICAM Dual Carrier Sound available for CCIR systems.

**PLATINUM EL SERIES®**

**5100, 1,000, 2,000 WATT SOLID STATE VHF TRANSMITTERS**

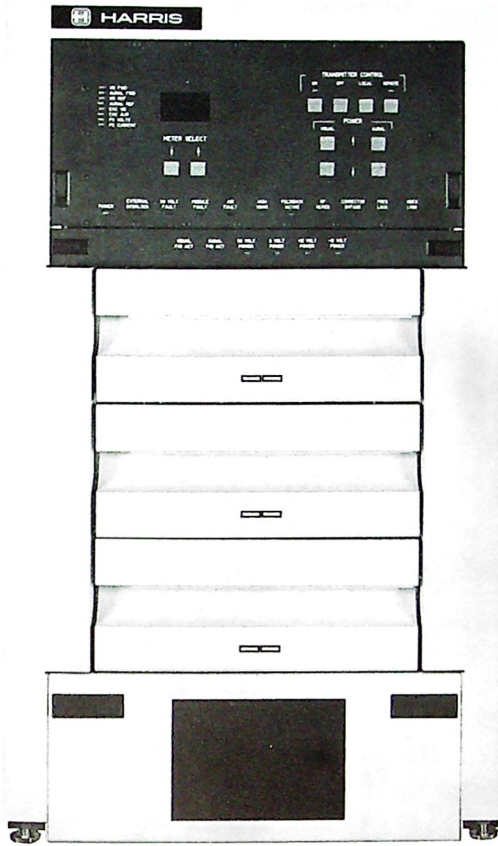

HT EL1000

Power Levels*:	
Model	Peak Visual Power
HT EL500LS/HS	500 W
HT EL1000LS/HS	1,000 W
HT EL2000LS/HS	2,000 W

\*LS Models: 47 - 88 MHz, CCIR systems M, N, B, D/K, K1, NTSC, PAL, SECAM color formats.  
 HS Models: 170 - 230 MHz, CCIR systems M, N, B, D/K, K1, NTSC, PAL SECAM color formats.

**KEY BENEFITS**

- ▶ Cost-effective, field-proven solid state transmitter designed for reliable, unattended operation.
- ▶ Available for any CCIR system; NTSC, PAL, SECAM color formats; monaural, BTSC, IRT, NICAM multi-channel sound formats.
- ▶ Highly modular transmitter houses combination visual/aural exciter and visual/aural power amplifier modules in single compact cabinet.
- ▶ Field-repairable broadband FET (Field Effect Transistor) power amplifier modules engineered for long life and reliable performance.
- ▶ Self-protected power amplifier modules provide visual diagnostics of six fault conditions: VSWR, RF input overdrive, amplifier balance, over/undervoltage, overtemperature, and DC FET switch failure.
- ▶ PA modules require no tuning; can be safely removed or inserted while transmitter continues to operate.
- ▶ Regulated power supply capable of handling  $\pm 10\%$  variation of incoming AC line voltages; fault-protected from overcurrent, overvoltage and overtemperature.
- ▶ 19" rack-mounted combination visual/aural exciter ensures high quality visual and aural performance; housed in slide-out drawer for easy access. (Please see Harris HX 1V Exciter information.)
- ▶ Redundant air-cooling system provides on-air maintenance capability; ensures lowest possible device operating temperature for long life.
- ▶ Engineered for easy operation by virtually any user.

Transmitters, VHF

**SPECIFICATIONS**

**GENERAL**

CCIR SYSTEMS M/N, B, D/K, I, K1.  
 COLOR FORMATS NTSC, PAL, SECAM.  
 SOUND FORMATS Monaural, BTSC, DUAL CARRIER (IRT), NICAM.  
 ELECTRICAL REQUIREMENTS 208/240 volts,  $\pm 10\%$ , single phase, 50/60 Hz.  
 RF LOAD IMPEDANCE 50 ohms.

**POWER CONSUMPTION (Typical)**

HT EL500LS/HS 2.7 kW, black picture.  
 HT EL1000LS/HS 3.5 kW, black picture.  
 HT EL2000LS/HS 7 kW, black picture.

**PHYSICAL DIMENSIONS/WEIGHT**

HT EL500LS/HS 26" (66 cm) W, 35" (89 cm) D, 45" (114 cm) H; 430 lbs. (195 kg).  
 HT EL1000LS/HS 26" (66 cm) W, 35" (89 cm) D, 45" (114 cm) H; 450 lbs. (205 kg).  
 HT EL2000LS/HS 26" (66 cm) W, 44" (112 cm) D, 72" (183 cm) H; 800 lbs. (363 kg).  
 TEMPERATURE RANGE 0 - 45° C.

**PERFORMANCE**

FREQUENCY STABILITY  $\pm 250$  Hz (over 30 days).  
 DIFFERENTIAL PHASE/GAIN  $1^\circ/3\%$ .  
 ICCPM  $\pm 1^\circ$  or better.  
 LUMINANCE NONLINEARITY 1 dB or better.  
 AURAL OUTPUT POWER 10% of visual; 20% optional.  
 AUDIO DISTORTION 0.2%.  
 AM/FM NOISE -55 dB/-60 dB.  
 FREQUENCY RESPONSE  $\pm 0.5$  dB (30 to 15,000 Hz).  
 HARMONIC DISTORTION 0.2%.

Specifications subject to change or revision.

## PLATINUM SERIES®

## 1 kW THROUGH 60 kW SOLID STATE VHF TV TRANSMITTERS

## Power Levels\*:

Model	Peak Visual Power
HT 1LS/HS	1 kW
HT 2LS/HS	2 kW
HT 5LS/HS	5 kW
HT 10LS/HS	10 kW
HT 15LS/HS	15 kW
HT 20LS/HS	20 kW
HT 30LS/HS	30 kW
HT 45LS/HS	45 kW
HT 60LS/HS	60 kW

\*LS Models: 47 - 88 MHz, CCIR systems M, N, B, D/K, K1, NTSC, PAL, SECAM color formats.

HS Models: 170 - 230 MHz, CCIR systems M, N, B, D/K, K1, NTSC, PAL, SECAM color formats.

## KEY BENEFITS

- ▶ Unsurpassed solid state reliability with FET (Field Effect Transistor) power amplifier modules; highly redundant design, and distributed architecture for cooling and control.
- ▶ Available for any CCIR system; NTSC, PAL, SECAM color formats; monaural, BTSC, IRT, NICAM multi-channel sound formats.
- ▶ Interchangeable visual and aural power amplifier modules self-protected from six fault conditions—VSWR, RF input overdrive, amplifier balance, under/overvoltage, over-temperature, and DC FET switch failure.
- ▶ Hot-pluggable power amplifier modules designed for safe removal and insertion while transmitter continues to operate; field repairable.
- ▶ Linear power supplies regulated to handle up to  $\pm 10$  percent incoming AC voltage variations and varying load currents; fault-protected from overcurrent, overvoltage and overtemperature.
- ▶ 19" rack-mounted combination visual aural exciter ensures high quality visual and aural performance; housed in slide-out drawer for easy access. (Please see Harris HX 1V Exciter information.)
- ▶ Reduced technical labor costs with low-maintenance design; annual maintenance time only 10% of requirement for older, tube transmitters.
- ▶ Maintenance can be performed while transmitter is operating.
- ▶ Provides simple operation, monitoring and maintenance for use by virtually any operator.
- ▶ Cost-effective power upgrades in the field with addition of power amplifier modules or cabinets.
- ▶ Available with Platinum Sentry option for control and monitoring of transmitters from a personal computer.



HT 30LS

## SPECIFICATIONS

## GENERAL

## CCIR SYSTEMS

M, N, B, D/K, K1; other systems available on request.

## COLOR FORMATS

NTSC, PAL, SECAM.

## SOUND FORMATS

Monaural, BTSC, IRT, NICAM multi-channel sound.

## ELECTRICAL REQUIREMENTS

208/240 volts,  $\pm 10\%$ , three phase, 50/60 Hz.

380/415 volts,  $\pm 10\%$ , three phase, 50 Hz.

## POWER CONSUMPTION (Typical)

	Black Picture	Average Picture
HT 1LS/HS	5.5 kW	
HT 2LS/HS	7.5 kW	6.9 kW
HT 5LS/HS	13.2 kW	11.2 kW
HT 10LS/HS	24.4 kW	19.3 kW
HT 15LS	32 kW	25 kW
HT 15HS	35 kW	28 kW
HT 20LS/HS	48 kW	37 kW
HT 30LS	63 kW	50 kW
HT 30HS	69 kW	55 kW
HT 45LS	93 kW	74 kW
HT 45HS	102 kW	81 kW
HT 60LS	123 kW	98 kW
HT 60HS	135 kW	108 kW

## PHYSICAL DIMENSIONS

HT 1LS/HS - HT 10LS/HS	57" (145 cm) W, 61.3" (156 cm) D, 72" (183 cm) H.
HT 15LS/HS, HT 20LS/HS	91" (231 cm) W, 61.3" (156 cm) D, 72" (183 cm) H.
HT 30LS/HS	125" (317.5 cm) W, 61.3" (156 cm) D, 72" (183 cm) H.
HT 45LS/HS	159" (404 cm) W, 61.3" (156 cm) D, 72" (183 cm) H.
HT 60LS/HS	227" (577 cm) W, 61.3" (156 cm) D, 72" (183 cm) H.

## WEIGHT

HT 1LS/HS	LS: 1,815 lbs. (825 kg); HS: 1,815 lbs. (825 kg).
HT 2LS/HS	LS: 1,840 lbs. (836 kg); HS: 1,840 lbs. (836 kg).
HT 5LS/HS	LS: 2,475 lbs. (1125 kg); HS: 2,500 lbs. (1136 kg).
HT 10LS/HS	LS: 2,720 lbs. (1236 kg); HS: 2,720 lbs. (1236 kg).
HT 15LS/HS	LS: 4,200 lbs. (1909 kg); HS: 4,900 lbs. (2227 kg).
HT 20LS/HS	LS: 5,000 lbs. (2273 kg); HS: 5,000 lbs. (2273 kg).
HT 30LS/HS	LS: 6,300 lbs. (2864 kg); HS: 6,750 lbs. (3068 kg).
HT 45LS/HS	LS: 8,590 lbs. (3905 kg); HS: 9,313 lbs. (4233 kg).
HT 60LS/HS	LS: 12,630 lbs. (5741 kg); HS: 13,760 lbs. (6255 kg).

## TEMPERATURE RANGE

0 - 50°C.

## PERFORMANCE

FREQUENCY STABILITY	$\pm 250$ Hz (over 30 days).
DIFFERENTIAL PHASE/GAIN	1°/3%.
ICPM	$\pm 1^\circ$ or better.
LUMINANCE NONLINEARITY	1 dB or better.
AURAL OUTPUT POWER	10% of visual; 20% optional.
AUDIO DISTORTION	0.2%.
AM/FM NOISE	-55 dB/-60 dB.
FREQUENCY RESPONSE	$\pm 0.5$ dB (30 to 15,000 Hz).
HARMONIC DISTORTION	0.2%.

**NAVIGATOR™ SERIES**

**10 - 1000 WATT SOLID STATE UHF TRANSMITTERS AND TRANSLATORS**

*Power Levels:*

Transmitter/Translator Model	Peak Visual Power
UTV-10*/UTV-10T*	10 W
UTV-100/UTV-100T	100 W
UTV-400/UTV-400T	400 W
UTV-750/UTV-750T	750 W
UTV-1000/UTV-1000T	1,000 W

\* Also available in models for Band III operation.

**KEY BENEFITS**

- ▶ Exceptional reliability with modular all-solid state design.
- ▶ Flexible design accommodates all CCIR systems, color standards, and multi-channel sound formats.
- ▶ Built-in redundancy with fault-protected RF devices; independent regulated power supplies for each amplifier.
- ▶ Field-repairable RF amplifiers require no adjustment.

- ▶ Engineered for superb performance with continuous black picture operation with SAW filter sideband shaping plus built-in IF pre-correction for linearity and incidental phase modulation; superior stability.
- ▶ Straightforward operation with extensive front-panel metering, at-a-glance status information and RF sample ports.
- ▶ Convenient remote control/telemetry/status interface; designed for unattended operation.

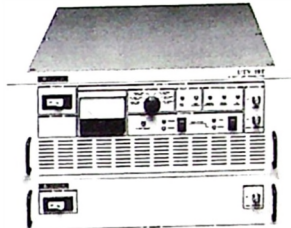

UTV-10T

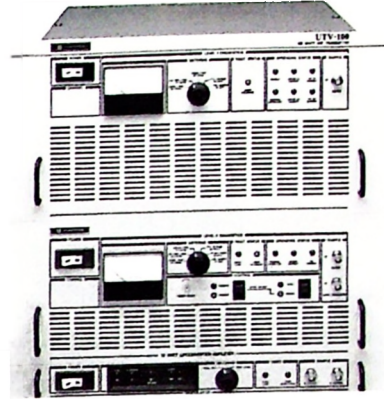

UTV-100

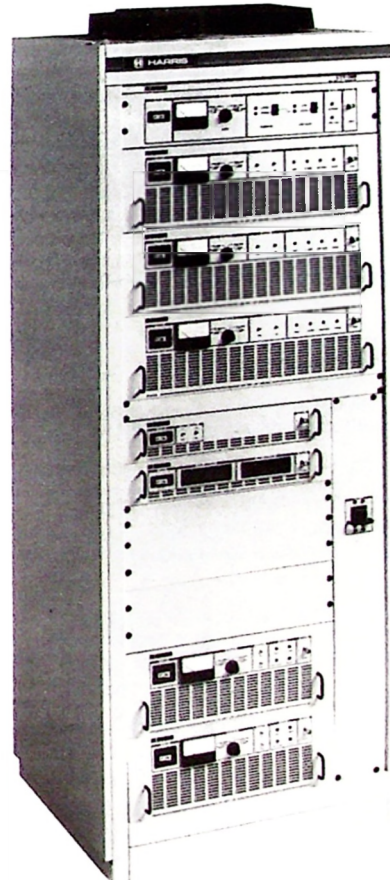

UTV-1000

**Transmitters, UHF**

**SPECIFICATIONS**

GENERAL	
CCIR SYSTEMS	D, G, I, K, K', M, N.
COLOR FORMATS	NTSC, PAL, SECAM.
SOUND FORMATS	Monoaural, BTSC, IRT, NICAM multi-channel sound.
TEMPERATURE RANGE	0° - 50° C.
ELECTRICAL REQUIREMENTS	208-240 volts, ±10%, single phase, 50/60 Hz.
POWER CONSUMPTION (Typical)	
UTV-10/UTV-10T	220 Watts, black picture.
UTV-100/UTV-100T	750 Watts, black picture.
UTV-400/UTV-400T	2 kW, black picture.
UTV-750/UTV-750T	3.8 kW, black picture.
UTV-1000/UTV-1000T	5.5 kW, black picture.
PHYSICAL DIMENSIONS/WEIGHT	
UTV-10/UTV-10T	222 mm H, 483 mm W, 762 mm D, 18.6 kg.
UTV-100/UTV-100T	444 mm H, 483 mm W, 762 mm D, 39 kg.
UTV-400/UTV-400T	1880 mm H, 660 mm W, 762 mm D, 218 kg.
UTV-750/UTV-750T	1880 mm H, 660 mm W, 762 mm D, 250 kg.
UTV-1000/UTV-1000T	1880 mm H, 660 mm W, 762 mm D, 273 kg.
COOLING SYSTEM	Convection and conduction.
PERFORMANCE	
FREQUENCY STABILITY	Transmitters: $5 \times 10^{-7}$ of visual carrier; high precision option available. Translators: $1 \times 10^{-6}$ of visual carrier.
DIFFERENTIAL PHASE/GAIN	3°/5%.
INTERMODULATION PRODUCTS	10 and 100 W models only: -52 dB.
ICPM	±3° or better, relative to blanking.
LUMINANCE NONLINEARITY	5% or better.
AURAL OUTPUT POWER	10% of visual.
AUDIO DISTORTION	0.5%.
AM/FM NOISE	AM: -55 dB; FM: -66 dB.
FREQUENCY RESPONSE	±0.5 dB, 30 Hz to 15 kHz.
HARMONIC DISTORTION	0.5% or less, 30 Hz to 15 kHz.

**NAVIGATOR™ SERIES**  
**5 AND 10 kW UHF TRANSMITTERS**

Transmitters, UHF

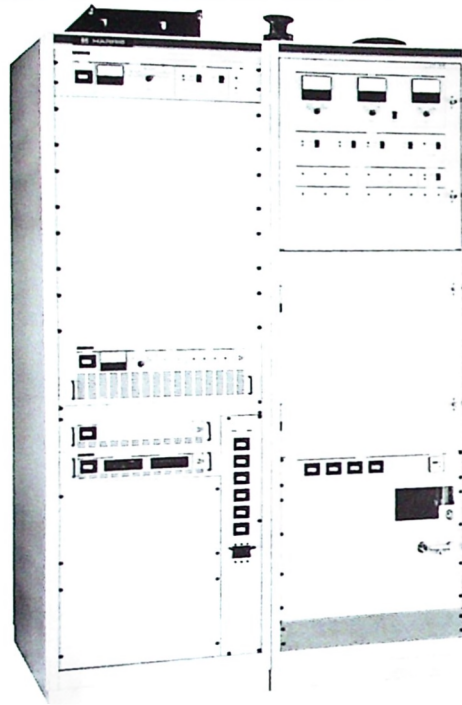

UTV-5000

Power Levels:	
Model	Peak Visual Power
UTV-5000	5 kW
UTV-10,000	10 kW

**KEY BENEFITS**

- ▶ 100% solid state driver stage with redundant solid state assemblies and conservatively-rated tetrode provide high reliability.
- ▶ Solid state driver assembly requires no tuning and is field-repairable.
- ▶ Superb performance; engineered for continuous black picture operation with SAW filter sideband shaping plus built-in IF pre-correction for linearity and incidental phase modulation; superior stability.
- ▶ Accommodates all CCIR TV systems, color standards and multi-channel sound formats.
- ▶ Designed for unattended operation with standard "connectorized" remote control/telemetry/status interface.
- ▶ Extensive front-panel metering for convenient status assessment.

**SPECIFICATIONS**

GENERAL

CCIR SYSTEMS

D, G, K, K', M, N, I.

COLOR FORMATS

NTSC, PAL, SECAM.

SOUND FORMATS

Monaural, BTSC, IRT, NICAM multi-channel sound.

TEMPERATURE RANGE

0° - 50° C.

ELECTRICAL REQUIREMENTS

208-240 volts, ±10%, three phase, 50/60 Hz.  
 380/415 volts, ±10%, three phase, 50 Hz.

POWER CONSUMPTION (Typical)

UTV-5000  
 UTV-10,000

17 kW, black picture.  
 28 kW, black picture.

PHYSICAL DIMENSIONS/WEIGHT

UTV-5000  
 UTV-10,000

1960 mm H, 1321 mm W, 762 mm D, 909 kg.  
 1960 mm H, 1321 mm W, 762 mm D, 1180 kg.

COOLING SYSTEM

Convection and conduction.

PERFORMANCE

FREQUENCY STABILITY

$5 \times 10^{-7}$  of visual carrier.

DIFFERENTIAL PHASE/GAIN

3°/5%.

INTERMODULATION PRODUCTS

5 kW only: -52 dB.

ICPM

±3° or better, relative to blanking.

LUMINANCE NONLINEARITY

5% or better.

AURAL OUTPUT POWER

10% of visual.

CARRIER DEVIATION (MAXIMUM)

±200 kHz.

AUDIO DISTORTION

0.5%.

AM/FM NOISE

AM: -55 dB; FM: -66 dB.

FREQUENCY RESPONSE

±0.5 dB, 30 Hz to 15 kHz.

HARMONIC DISTORTION

0.5% or less, 30 Hz to 15 kHz.



**SCEPTRE SERIES**

**2 - 40 kW SOLID STATE UHF TRANSMITTERS**



SCEPTRE 5 kW

**SPECIFICATIONS**

<b>GENERAL</b>	
CCIR SYSTEMS	G, H, I, K, K', M, N.
COLOR FORMATS	NTSC, PAL, SECAM.
SOUND FORMATS	Monaural, BTSC, IRT, NICAM G, NICAM I.
TEMPERATURE RANGE	0° - 45° C.
MAXIMUM HUMIDITY	90% non-condensing.
ELECTRICAL REQUIREMENTS	380 (-15%) to 415 (+10%) V. 460 (-17%) to 480 (+12%) V. Three phase, four wire, 47 - 63 Hz; other voltages on request.
<b>POWER CONSUMPTION (Typical)</b>	<b>System M,</b>
3 kW	BTSC 10 kW
5 kW	14 kW
10 kW	27 kW
15 kW	40 kW
<b>PHYSICAL DIMENSIONS/TRANSMITTERS</b>	
3 and 5 kW	54.3" (1380 mm) W, 57" (1450 mm) D, 71" (1811 mm) H.
10 kW	85.8" (2180 mm) W, 57" (1450 mm) D, 71" (1811 mm) H.
15 kW	117" (2980 mm) W, 57" (1450 mm) D, 71" (1811 mm) H.
COMBINER (all)	23" (590 mm) W, 57" (1450 mm) D, 71" (1811 mm) H.
<b>REMOTE CONTROL</b>	Serial data RS 232.
<b>PERFORMANCE</b>	
FREQUENCY STABILITY	±200 Hz/month.
DIFFERENTIAL PHASE/GAIN	3°/5%.
ICPM	±2°, relative to blanking.
LUMINANCE NONLINEARITY	1.0 dB or better.
AURAL OUTPUT POWER	10% of visual.
AUDIO DISTORTION	0.5%.
AM/FM NOISE	AM: -50 dB; FM: -60 dB.
FREQUENCY RESPONSE	+0.5 dB, 30 Hz to 15 kHz.
HARMONIC DISTORTION	0.5% or less, 30 Hz to 7.5 kHz.

*Power Levels:*

Model	Peak Visual Power
Type 2030	3 kW
Type 2050	5 kW
Type 2100	10 kW
Type 2150	15 kW
2 X 2150	30 kW

**KEY BENEFITS**

- ▶ High reliability with modular power block architecture; various power levels achieved by assembling identical solid state PA modules and power supplies in a parallel configuration.
- ▶ Features uniquely broadband (470 - 860 MHz) PA modules and combiners; because visual and aural modules are identical, any Sceptre module can be used for either visual or aural in any Sceptre transmitter on any channel!
- ▶ Ultra-soft failure design allows continued transmitter operation should an amplifier module or a power supply fail; enables repairs to be scheduled on convenient rather than emergency basis.
- ▶ Hot-pluggable PA modules can be removed and inserted safely during transmitter operation.
- ▶ Models to meet every world standard using negative visual modulation.
- ▶ APL-related linearity distortion eliminated by dynamic compensation.
- ▶ Available with BTSC, IRT or NICAM multi-channel sound.
- ▶ Compact high efficiency combining system with circulator isolation of power blocks.
- ▶ Low long-term cost of ownership with no tube replacements or associated labor expenses; significantly reduced routine maintenance requirements.
- ▶ User-friendly design with processor-based central monitoring system and VDU display.
- ▶ Designed for unattended operation; remote control, telemetry and modem options.
- ▶ Features simple air-cooling system.
- ▶ Compact layout requires minimum floor space.
- ▶ Complies with IEC 215 international safety standard.

**Transmitters, UHF**

## 1740 SERIES 5 - 30 kW KLYSTRON UHF TRANSMITTERS

Power Levels:		
Model	Power Output	Amplification
Type 1740	5 - 15 kW	Combined
Type 1741	10 - 15 kW	Separate
Type 1742	20 - 30 kW	Separate

### KEY BENEFITS

- ▶ Compact reliable long life klystron tubes available from multiple sources.
- ▶ Rugged integral beam pulser ensures high efficiency.
- ▶ Single external cavity tube type covers all UHF channels.
- ▶ High performance IF modulated type 1170 drive with SAW filter and precise pre-correction.
- ▶ Suitable for stereo/multi-channel sound systems.
- ▶ Designed for unattended operation with logic control of start/stop sequences and continuous performance monitoring.
- ▶ Compact design with integral power supplies.
- ▶ Simple compact vapor cooling system.
- ▶ Complies with IEC 215 international safety standard.
- ▶ Suitable for single operation, in passive reserve or parallel systems.



1740 SERIES TRANSMITTER

### SPECIFICATIONS

#### GENERAL

CCIR SYSTEMS

G, H, I, K, K', M, N.

COLOR FORMATS

NTSC, PAL, SECAM.

SOUND FORMATS

Monaural, BTSC, IRT, NICAM G, NICAM I.

TEMPERATURE RANGE

2° - 45° C.

ELECTRICAL REQUIREMENTS

380-415 VAC  $\pm 2\%$ , 3 phase, 4 wire, phase asymmetry  $\pm 2\%$ , 47-63 Hz

POWER CONSUMPTION (Typical  $\rightarrow$ )

Type 1740: 5 kW output, 33 kW, 10 kW output, 59 kW; 15 kW output, 85 kW.

Type 1741: 10 kW output, 30 kW, 15 kW output, 41 kW.

Type 1742: 20 kW output, 52 kW; 25 kW output, 63 kW output; 30 kW output, 73 kW.

PHYSICAL DIMENSIONS

Type 1740: 102.3" (2600 mm) W, 44.37" (1127 mm) D, 76" (1930 mm) H  
Type 1741 and 1742: 133.5" (3390 mm) W, 44.37" (1400 mm) D, 76" (1930 mm) H.

Combiner: 23.2" (590 mm) W, 55" (1400 mm) D, 76" (1930 mm) H.

#### PERFORMANCE

FREQUENCY STABILITY

$\pm 200$  Hz/month.

DIFFERENTIAL PHASE/GAIN

3°/5%.

ICPM

$\pm 2^\circ$ , relative to blanking.

LUMINANCE NONLINEARITY

$\leq 1.0$  dB.

AURAL OUTPUT POWER

10% of visual.

AUDIO DISTORTION

0.5%.

AM/FM NOISE

AM: -50 dB; FM: -60 dB.

FREQUENCY RESPONSE

+0.5 dB, 30 Hz to 15 kHz.

HARMONIC DISTORTION

0.5% or less, 30 Hz to 7.5 kHz.

NOTE: Typical for mono or BTSC; increase by 15% for IRT or NICAM (Type 1740 not suitable for IRT or NICAM), including cooling. Power factor 0.9.

1790 SERIES

30 - 240 kW KLYSTRON UHF TRANSMITTERS

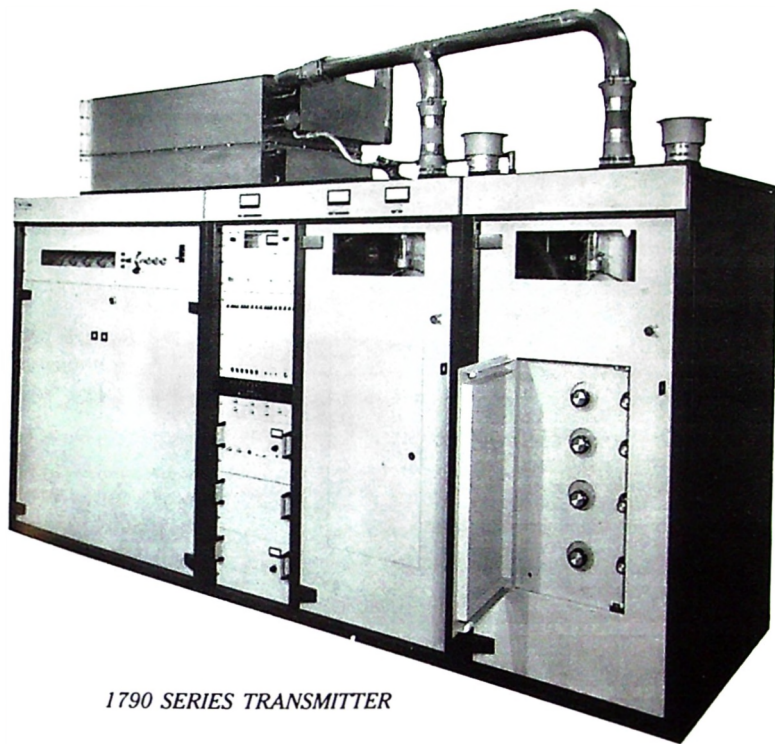

1790 SERIES TRANSMITTER

SPECIFICATIONS

GENERAL	G, H, I, K, K <sup>1</sup> , M, N.
CCIR SYSTEMS	NTSC, PAL, SECAM.
COLOR FORMATS	Monaural, BTSC, IRT, NICAM G, NICAM I.
SOUND FORMATS	2°C to 45°C at 500 meters, derating to 25° at 2000 meters.
TEMPERATURE RANGE	0 to 90% non-condensing.
HUMIDITY RANGE	380-415 VAC ±2%, 3 phase, 4 wire, phase asymmetry ±2%, 47-63 Hz.
ELECTRICAL REQUIREMENTS	Type 1790: 30 kW output, 149 kW.
POWER CONSUMPTION (Typical)	Type 1792: 40 kW output, 98 kW.
	Type 1791: 60 kW output, 128 kW.
	2 x 1790: 60 kW output, 133 kW.
	1791 + 1792: 120 kW output, 254 kW.
	3 x 1790: 120 output, 259 kW.
	1791 + 3 X 1790: 240 kW output, 504 kW.
	2 (1791 + 1790): 240 kW output, 508 kW.
PHYSICAL DIMENSIONS	Type 1790: 118.5" (3010 mm) W, 44.37" (1127 mm) D, 76" (1930 mm) H.
	Type 1791 and 1792: 153.5" (3900 mm) W, 44.37" (1127 mm) D, 76" (1930 mm) H.
	Plus external cooling equipment.
PERFORMANCE	
FREQUENCY STABILITY	±200 Hz/month.
DIFFERENTIAL PHASE/GAIN	3°/5%.
ICPM	±2°, relative to blanking.
LUMINANCE NONLINEARITY	≤1.0 dB.
AURAL OUTPUT POWER	10% of visual.
AUDIO DISTORTION	0.5%.
AM/FM NOISE	AM: -50 dB; FM: -60 dB.
FREQUENCY RESPONSE	+0.5 dB, 30 Hz to 15 kHz.
HARMONIC DISTORTION	0.5% or less, 30 Hz to 7.5 kHz.

<sup>1</sup> Typical for mono or BTSC; increase by 15% for IRT or NICAM (Type 1740 not suitable for IRT or NICAM), including cooling. Power factor 0.9.

Power Levels.

Model	Power Output	Amplification
Type 1790	30 kW	Combined
Type 1792	40 kW	Separate
Type 1791	60 kW	Separate
2 X 1790	60 kW	Separate
1791 + 1790	120 kW	Separate
3 X 1790	120 kW	Separate
1791 + 3 X 1790	240 kW	Separate
2 (1791 + 1790)	240 kW	Separate

KEY BENEFITS

- ▶ Compact reliable long life klystron tubes available from multiple sources.
- ▶ Rugged integral beam pulser ensures high efficiency.
- ▶ Single external cavity tube type covers all UHF channels.
- ▶ High performance IF modulated type 1170 drive with SAW filter and precise precorrection.
- ▶ Suitable for stereo/multi-channel sound systems.
- ▶ Designed for unattended operation with logic control of start/stop sequences and continuous performance monitoring.
- ▶ Compact design with integral power supplies.
- ▶ Simple compact vapor cooling system.
- ▶ Complies with IEC 215 international safety standard.
- ▶ Suitable for single operation, in passive reserve or parallel systems.

Transmitters, UHF

**SIGMA™ SERIES**  
**15 - 240 kW IOT UHF TRANSMITTERS**

Transmitters, UHF

Power Levels:		
Combined Visual/Aural*		
Model	40 kW IOT	60 kW IOT
HD 30C1	30 kW, 1 IOT	
HD 40C1		40 kW, 1 IOT
HD 60C2	60 kW, 2 IOT	
HD 80C2		80 kW, 2 IOTs
HD 90C3	90 kW, 3 IOTs	
HD 120C3		120 kW, 3 IOTs
HD 120C4	120 kW, 4 IOTs	
HD 160C4		160 kW, 4 IOTs

\*Separate Visual/Aural models also available.

**KEY BENEFITS**

- ▶ Ideal for the transition to Advanced Television (ATV), providing exceptional efficiency and performance to today and ATV capability for the future.
- ▶ Uncompromised performance and exceptional linearity via patented correction circuits in the IPA and exciter. These circuits, in addition to other correctors, produce very low levels of intermodulation between luminance, color and aural signals.
- ▶ Ready for ATV standards of the future with linearity and headroom that will transmit high quality digital bit stream signals.
- ▶ Unsurpassed reliability with all multiple tube configurations; transmitters will continue to operate at reduced power should a fault occur.
- ▶ Extensive redundancy: Each power amplifier cabinet features its own IPA, power supplies, cooling system with redundant fans and dual pumps, plus control and monitoring for high system redundancy.
- ▶ Longer tube life with thyatron over-current protection for each IOT.
- ▶ Maximum user simplicity with straightforward logic control of transmitter on/off sequences, fast-acting fault protection and front-panel LED status indicators, and extensive remote status and measurement interface.
- ▶ Excellent serviceability with Mean Time to Repair (MTTR) for any subassembly of 30 minutes.
- ▶ Sigma transmitters comply with rigorous IEC-215 safety standards.
- ▶ Low long-term cost of ownership with typical transmitter system efficiency<sup>1</sup> exceeding 70%.
- ▶ Flexible family architecture and wide variety of options enable you to tailor your transmitter for your specific application.

<sup>1</sup>Includes transmitter, cooling and support equipment.



HD 60C2/HD 80C2

**SPECIFICATIONS**

**GENERAL**

CCIR SYSTEMS	D, G, I, K, K', M, N.
COLOR FORMATS	NTSC, PAL, SECAM.
SOUND FORMATS	Monaural, BTSC, IRT, NICAM multi-channel sound.
TEMPERATURE RANGE	0° to 45° to 500 meters.
HUMIDITY RANGE	0 to 90% relative humidity, non-condensing.
ELECTRICAL REQUIREMENTS	380-460 VAC, 3 phase, 50/60 Hz; other voltages available on request.

**POWER CONSUMPTION (Typical)**

Black picture:  
 HD 30C1: 58.1 kW  
 HD 60C2: 112.7 kW  
 HD 90C3: 167.7 kW  
 HD 120C4: 223.5 kW

**SYSTEM EFFICIENCY**

70% typical.

**PHYSICAL DIMENSIONS**

HD 30C1/40C1: 82" (208 cm) W, 55" (139.7 cm) D, 72" (183 cm) H.  
 HD 60C2/80C2: 140.5" (356.9 cm) W, 55" (139.7 cm) D, 72" (183 cm) H.  
 HD 90C3/120C3: 199" (505.5 cm) W, 55" (139.7 cm) D, 72" (183 cm) H.  
 HD 120C4/160C4: 257.5" (654.5 cm) W, 55" (139.7 cm) D, 72" (183 cm) H.  
 Power Supply: 52" (132 cm) W, 70.75" (179.7 cm) D, 67" (170 cm) H.  
 Pump Module: 32.25" (81.9 cm) W, 30.25" (76.8 cm) D, 19" (48.3 cm) H.  
 Fan Unit: 43.56" (110.6 cm) W, 91.5" (232.4 cm) D, 43.13" (109.55 cm) H.  
 Line Control: 36.25" (92 cm) W, 12" (30.48 cm) D, 60" (152.4 cm) H.

**PERFORMANCE**

FREQUENCY STABILITY	±200 Hz/month.
DIFFERENTIAL PHASE/GAIN	3°/5%.
ICPM	±2°, relative to blanking.
LUMINANCE NONLINEARITY	10% or better.
AURAL OUTPUT POWER	10% of visual.
AUDIO DISTORTION	0.5%.
AM/FM NOISE	AM: -55 dB; FM: -70 dB.
FREQUENCY RESPONSE	+0.5 dB, 30 Hz to 15 kHz, with pre-emphasis.
HARMONIC DISTORTION	0.5% or less, 30 Hz to 15 kHz.

Specifications subject to change or revision.

UM SERIES

60 - 280 kW DEPRESSED COLLECTOR KLYSTRON UHF TRANSMITTERS

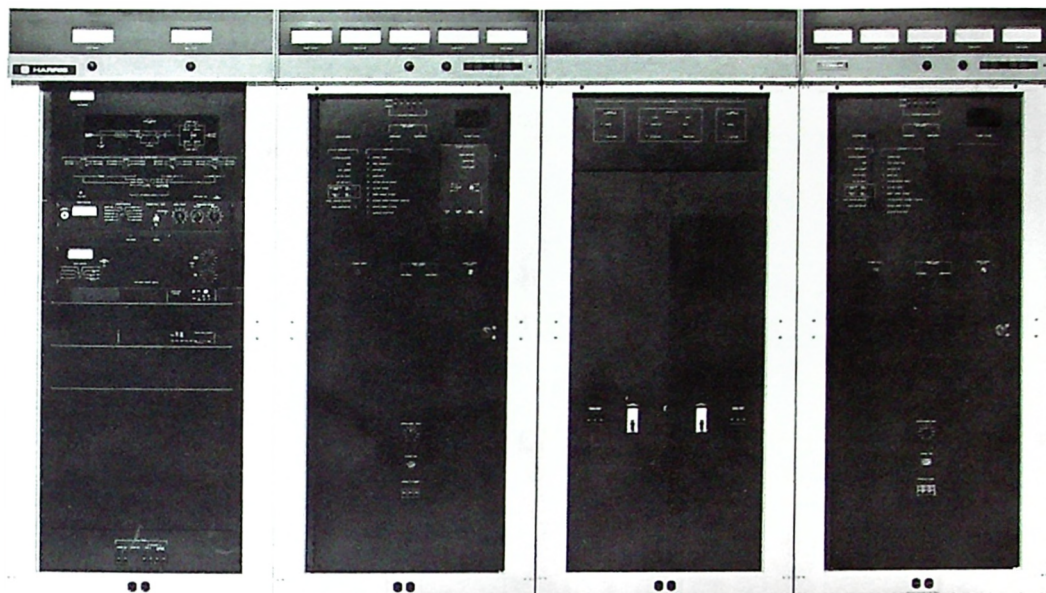

TV-60UM

Transmitters, UHF

Power Levels*	
Model	Power Output
TV-60UM	60 kW
TV-120UM	120 kW
TV-180UM	180 kW
TV-240UM	240 kW

\*70 kW depressed collector klystron also available.

KEY BENEFITS

- ▶ High efficiency depressed collector klystron power amplifiers with figure of merit greater than 1.30 reduce power consumption by up to 50%.
- ▶ Depressed collector klystrons feature proven and familiar external cavity klystron technology.
- ▶ Wideband depressed collector klystrons available from multiple sources.
- ▶ Harris' exclusive two-stage liquid and air cooling system extends klystron life by maintaining lowest operating temperatures for tubes and cavities.
- ▶ Cooling system features include redundant pumps in liquid pump module; three-stage passive filtering, and transmitter front panel LEDs to indicate when filters need replacement. Designed for on-air filter replacement.
- ▶ Exceptional transmitter performance provided with MCP-UX exciter with SAW filter, solid state IPAs, and independent pulsers for each klystron.
- ▶ Maximum serviceability with easy access to components; exclusive breakaway line section to facilitate tube replacement; independent amplifier shutdown which allows one PA to be serviced while other remains on air.
- ▶ Extensive front panel diagnostics provide at-a-glance status information.
- ▶ Independent automatic interlock shutdown protection meets IEC 215 requirements.

SPECIFICATIONS

GENERAL	
CCIR SYSTEMS	M.
COLOR FORMATS	NTSC.
TEMPERATURE RANGE	2°C to 50°C.
HUMIDITY RANGE	0 to 95% relative humidity, non-condensing.
ELECTRICAL REQUIREMENTS	460/480/500 volts, ±5%, 3 phase, 60 Hz.
POWER CONSUMPTION (Typical)	(10% aural, 50% APL) TV-60UM: 92 kW; TV-120UM: 165 kW; (20% aural) TV-60UM: 110 kW; TV-120UM: 190 kW.
PHYSICAL DIMENSIONS	TV-60UM: 126" (320 cm) W, 74" (189.4 cm) D, 73.5" (186.7 cm) H. TV-120UM: 189" (480 cm) W, 74" (189.4 cm) D, 73.5" (186.7 cm) H. Power Supply: 52" (132 cm) W, 68" (172.72 cm) D, 67.5" (171.45 cm) H. Pump Module: 36" (91.44 cm) W, 61" (154.94 cm) D, 64" (162.56 cm) H. Fan/Coil Module: TV-60UM: 44" (111.76 cm) W, 92" (233.68 cm) D, 43" (109.22 cm) H; TV-120UM: 86" (218.44 cm) W, 119" (302.26 cm) D, 50" (127 cm) H. Line Control: 24" (60.96 cm) W, 24" (60.96 cm) D, 48" (121.92 cm) H.
PERFORMANCE	
FREQUENCY STABILITY	±500 Hz, maximum variation over 30 days.
DIFFERENTIAL PHASE/GAIN	3°/5%.
ICPM	±2° or better, relative to blanking.
LUMINANCE NONLINEARITY	1.0 dB or better.
AURAL OUTPUT POWER	Up to 20% of visual.
AUDIO DISTORTION	0.5%.
AM/FM NOISE	AM: -55 dB; FM: -60 dB.
FREQUENCY RESPONSE	+0.5 dB, 30 Hz to 15 kHz.
HARMONIC DISTORTION	0.5% or less, 30 Hz to 15 kHz after de-emphasis.

Specifications subject to change or revision.



## CABLEWAVE

### FM Broadcast Antennas

Cablewave Systems offers a comprehensive line of omni-directional antenna systems and accessories for the FM broadcast industry. CFM LP/HP circularly polarized antennas and HFM LP/HP horizontally polarized antennas are designed for high power commercial broadcast applications and have a power handling capability of 5 to 40 kilowatts depending on the specific antenna configuration. CP-1000 circularly polarized antennas and HP-1000 horizontally polarized antennas provide a low power alternative to the CFM and HFM antennas for applications up to 4 kilowatts where high power handling is not required. Cablewave manufactures a complete line of rigid coaxial transmission lines and components, cables, connectors and accessories. See Page 217 of this catalog.

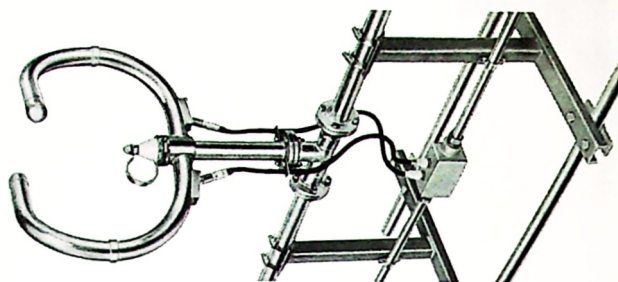

*Circularly Polarized FM Antenna*

### MARK



*Super Short Haul Antenna*

#### Super Short Haul Antenna

The Mark Super Short Haul is a welded aluminum grid parabolic section antenna for point-to-point communication in the 940-960 MHz frequency range. It provides an increased gain of 1.5 dBi over the standard Short Haul Antenna. Improvements were made in narrowing the main beam, side-lobe performance and front-to-back without increasing size. The Super Short Haul Antenna is UPS shippable. *Harris Allied carries the complete line of Mark Antennas.*

### MARTI

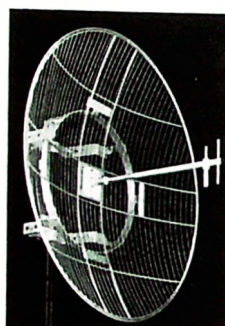

*SC-48 Parabolic Antenna*

#### SC-48 Parabolic Antenna

The Marti SC-48 stainless 4' full-parabolic antenna is the answer to high antenna costs. The SC-48 is broadband for the 940 to 960 MHz aural STL band and has the specifications for getting the most from your Marti STL system. The SC-48 is category B rated in vertical and horizontal planes. The 16 degree 1/2 power beamwidth is the maximum beamwidth of a 4' parabola is capable of at 950 MHz. *Harris Allied carries the complete line of Marti Antennas.*

### JAMPRO

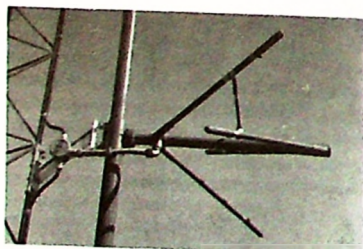

*Series B Antenna*

#### JSCP Series B Antenna

The Jampro JSCP Series B antenna is the industry standard in circularly polarized FM broadcast antennas. It is available in 14 bay configurations ranging from 0.46 to 8.9 power gain and 25 to 1175 lbs. with brackets. They are tuned at the factory with excellent VSWR bandwidth. Features include superior performance for stereo and SCA broadcasting plus true circular polarization. These and many other features makes these great performers.

### SCALA



*PR Series Paraflector*

#### PR Series Paraflector

The Scala PR Series is widely used in point-to-point communications and telemetry systems in the 350 to 1000 MHz spectrum. Paraflector™ performance approximates that of a parabolic dish of the same aperture and is easier to assemble and install. The PR Series offers rugged construction for reliable long-term service, even in severe environmental conditions. The PR Series is fabricated using anodized 6061-T6 aluminum pipe and tubing, heavy aluminum castings and stainless steel fastenings and hardware. Order according to frequency.

*Harris Allied carries most antennas & accessories available. Please contact us for details and specifications such as power gain, construction, weight, dimensions and frequencies. Let us "fit" the right antenna for you.*



## Total Antenna Capabilities

At Harris Allied, we understand that many broadcasters regard the antenna as the most complex component in broadcasting. But we also know it is one of the most critical. This is why we provide total antenna capabilities.

We can provide standard, cost-effective off-the-shelf antennas or custom systems that are engineered, manufactured and tested to meet your most exacting requirements. We can

provide any level of support you want, including rapid emergency standby antenna turn-around. And we offer the most extensive after-sales support of any broadcast supplier in the world.

Whether you are considering a simple stand-by antenna, a primary broadcasting antenna or phasor, a custom-designed RF system, or a multi-site turnkey broadcast network, we invite you to contact us:

### INTERNATIONAL:

Telephone: 217-222-8290

FAX: 217-224-2764

### U.S. AND CANADA:

Telephone: 217-222-8200

FAX: 217-224-1439

# HARRIS

## MEDIUM WAVE PHASORS, ANTENNA COUPLING UNITS, DIPLEXERS, ACCESSORIES

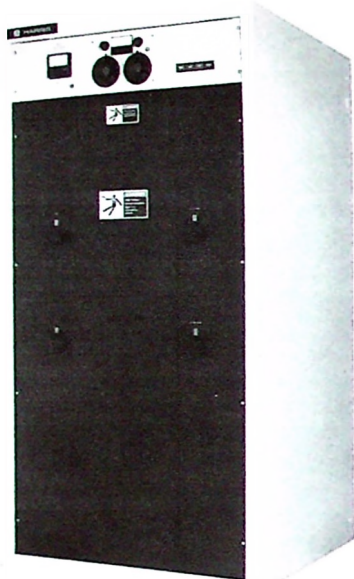

STANDARD PHASOR

### KEY BENEFITS

- ▶ Power levels available from 250 watts through 1.5 megawatts.
- ▶ Harris is experienced in assembling consultant-designed phasors which typically have highly customized parts.
- ▶ Computer-aided design and analysis of complete phasing system ensures best impedance and pattern bandwidth attainable for any given pattern.
- ▶ Complete line of phasing and ACU cabinets is available for almost any need. Wall panel construction is also offered.
- ▶ Factory pretuning to predicted values with a vector impedance meter and network analyzer ensures accurate impedance matches and phase shifts and can greatly reduce initial set-up time.
- ▶ Cabinets use an alodyne finish to improve conductivity. Copper ground straps are available to enhance electrical conductivity.
- ▶ Silver-plated coils and tubing are used throughout the system. Silver-plated strapping is used only on fixed coils for flexible shorting applications.
- ▶ Convenient test jacks are included at points where measurements are to be taken. Jacks are installed so that leads from an RF impedance bridge do not cross.
- ▶ Horn gaps are available for improved lightning protection.
- ▶ Phasor cabinets are available with front-panel Delta Common Point Bridge and RF ammeter.
- ▶ Front and rear panels make all phasor components easily accessible. Phasor cabinet rear panels are interlocked with the transmitters, to ensure personnel safety.
- ▶ Weather-proof ACU/Diplexer cabinets use a front-door lock to prevent unauthorized entry.
- ▶ Front-panel cyclometers with counter dials for variable components facilitate adjustment.
- ▶ Cabinet interior lights available.

### STANDARD HARRIS ACUs

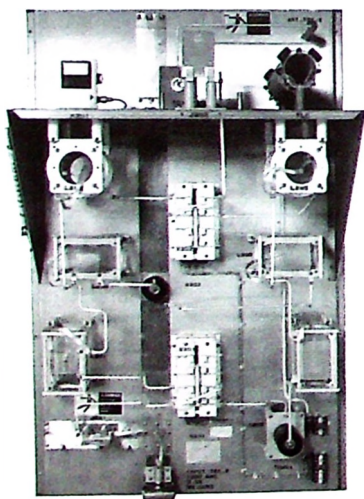

ACU

Model	ACU-1	ACU-2.5	ACU-5	ACU-10	ACU-25	ACU-50
POWER*	1000 W	2500 W	5000 W	10,000 W	25,000 W	50,000 W
NETWORK	FULL T	FULL T	FULL T	FULL T	FULL T	FULL T
INPUT IMPEDANCE	50 OHMS* TYPICAL	50 OHMS* TYPICAL	50 OHMS* TYPICAL	50 OHMS* TYPICAL	50 OHMS* TYPICAL	50 OHMS* TYPICAL
TOWER HEIGHT	70 - 195 Degrees**	70 - 195 Degrees**	70 - 195 Degrees**	70 - 195 Degrees**	70 - 195 Degrees**	70 - 195 Degrees**
STATIC DRAIN CHOKE	INCLUDED	INCLUDED	INCLUDED	INCLUDED	INCLUDED	INCLUDED
TOWER LIGHTING CHOKE	OPTIONAL	OPTIONAL	OPTIONAL	OPTIONAL	OPTIONAL	OPTIONAL
THERMO COUPLE METER	AVAILABLE	AVAILABLE	AVAILABLE	AVAILABLE	—	—
TORROIDAL TRANSFORMER METER	AVAILABLE	AVAILABLE	AVAILABLE	AVAILABLE	AVAILABLE	AVAILABLE
INTERIOR LIGHTING	OPTIONAL	OPTIONAL	OPTIONAL	OPTIONAL	OPTIONAL	OPTIONAL
WEATHER PROOF ENCLOSURE	AVAILABLE 40"W x 30"H x 28"D	AVAILABLE 40"W x 30"H x 28"D	AVAILABLE 40"W x 30"H x 28"D	AVAILABLE 52"W x 42"H x 32"D	AVAILABLE 36"W x 78"H x 42"D	AVAILABLE VARIABLE
WALL PANEL MOUNT	AVAILABLE	AVAILABLE	AVAILABLE	AVAILABLE	AVAILABLE	AVAILABLE

\*Higher powers available on request.  
\*\*Others available on request.



## HS-4P 30 AMP RF CONTACTOR



- ▶ Provides trouble-free operation in phasors, ACUs, transmitter dummy load switching or any similar RF switching application; provides reliable operation over wide temperature range.
- ▶ Requires no adjustment.
- ▶ Uses only 1/16 the power of conventional contactors.
- ▶ Has anticipated life of 30 years under normal use.

## 44-PORT MOTORIZED TRANSFER SWITCH

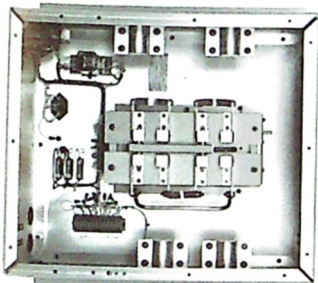

- ▶ Handles up to 8 kW RF power at 125% modulation.
- ▶ Transfers main or auxiliary transmitter to station antenna system or test load (optional); designed around Harris' HS-4P RF Motorized Contactor, transfer time is less than 0.5 seconds.
- ▶ Features push-button control operation and switch position indicator lights on 19-inch rack-mount panel.
- ▶ Accommodates 208/240 VAC, 50/60 Hz; remote operation by contact closure rated at 24 VDC, 0.5 amp.

## IMPEDANCE MATCHER

- ▶ Power levels available from 250 watts to 1.5 megawatts.
- ▶ Allows transmission lines with other than 50 ohm impedance to connect to a 50 ohm transmitter.
- ▶ Factory pre-tuned to calculated values with vector impedance meter to greatly reduce set-up time.
- ▶ Aluminum enclosure with alodine finish ensures good conductivity and corrosion resistance.

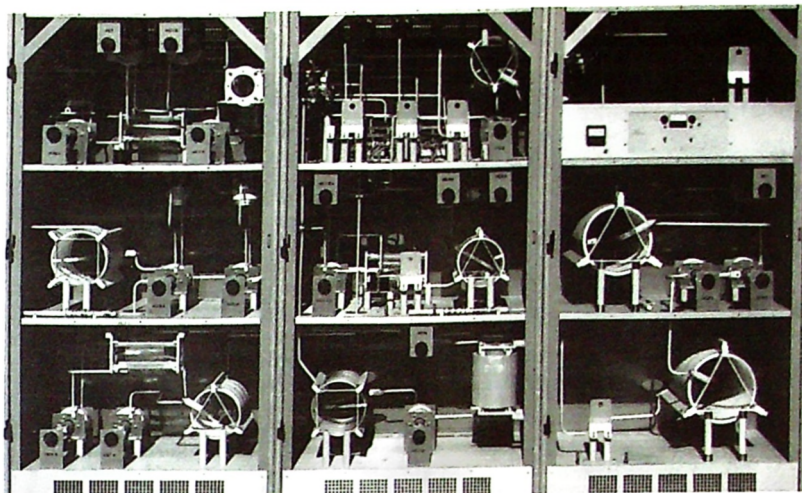

## CONSULTANT-DESIGNED PHASOR ISOLATION COIL

- ▶ Allows a non-insulated RF sample loop's coaxial cable to cross the base insulator of antenna tower.
- ▶ Options on coaxial cable line size and manufacturer; connector types on either end, and weatherproof or non-weatherproof enclosure.
- ▶ Optional resonating capacitor to present a very high impedance at the operating frequency.
- ▶ Constructed with the same type of coaxial cable used in the sampling system; unique intertwining cable design ensures consistency and stability.

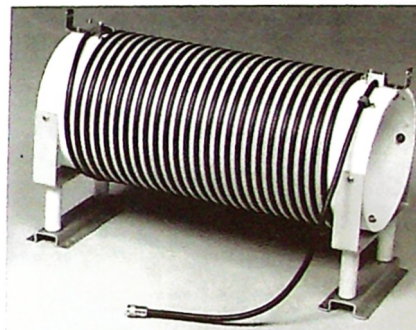

## POWER SPLITTER

- ▶ Allows smaller portion of overall power to be used when transmitter is unable to drop its power output to the desired level.
- ▶ Can couple transmitter to any transmission line characteristic impedance.
- ▶ Factory pre-tuned to calculated values with vector impedance meter.
- ▶ Aluminum enclosure with alodine finish can be constructed to desired dimensions.

## CHOKES



- ▶ Two models available: Static Drain Choke provides DC path to ground. Tower Lighting Choke provides DC path to ground and transfers AC power to tower lights.

## TEST JACKS

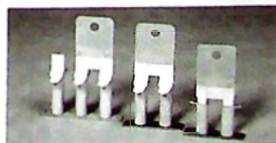

- ▶ Three types available, including low current and high current two-pole jacks as well as a three-pole jack for switching between a common and two poles.

## SILVER PLATED COILS

- ▶ Harris carries a complete line of fixed and variable coils. Fixed coils are rated to 150 amps (larger current ratings available on request).

## RF CURRENT METERS

- ▶ Two models available: Toroidal Current Meter obtains sample voltage proportional to the RF current flowing through the conductor. Thermocouple Meter plugs directly in-line with the circuit using a special "make before break" jack.

## HORN GAP (IN PHASING CIRCUITS)

- ▶ Helps protect equipment from lightning strikes.

## MICA AND VACUUM CAPACITORS

- ▶ Many different types available.

FM SERIES ANTENNAS

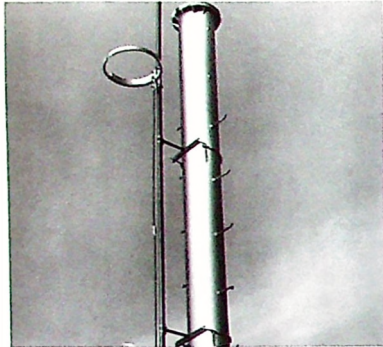

EDUCATIONAL

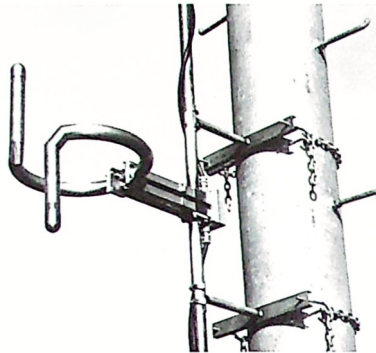

FMC

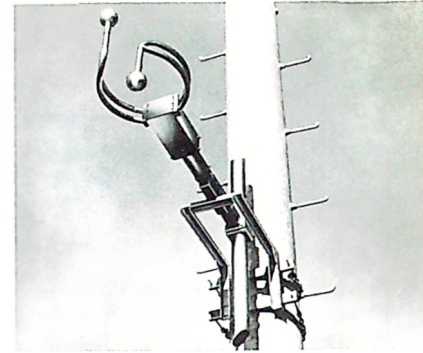

FMS

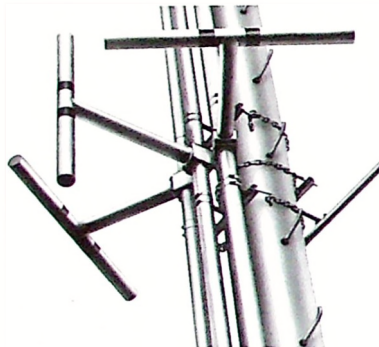

FMD

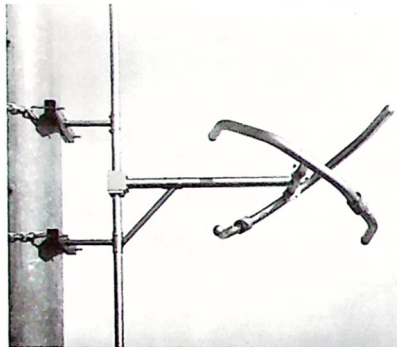

FML

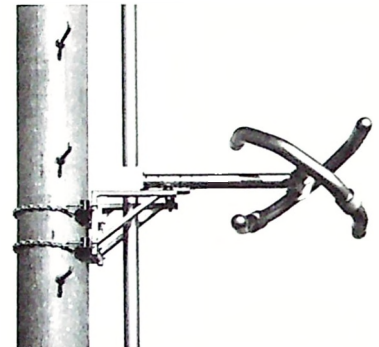

FMH

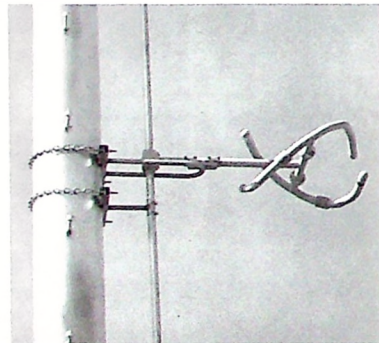

FMXL



FMXH

KEY BENEFITS

- ▶ Power ratings to meet every application.
- ▶ Excellent bandwidth for top stereo/SCA performance.
- ▶ Designed for long life and trouble-free maintenance with rugged brass and stainless steel construction.
- ▶ Fully assembled and tested to ensure top performance.
- ▶ Brackets included for face or leg mount on typical tower.
- ▶ Options include half-wave element spacing; electrical de-icers or radomes, and pattern testing/optimization with custom measurements on your frequency and tower size.

Other Harris FM antennas include the multi-channel Cavity-Backed Radiator (CBR) antenna which allows up to ten stations to share coverage benefits; the Batwing antenna for high power horizontally polarized applications, and the Deltawing antenna which provides unlimited pattern control for directional applications.

Models:

Educational 300V Series  
 FMC FMD FMS  
 FML FMXL  
 FMH FMXH

All standard Harris FM antennas\* have the same published gain for equivalent number of bays as shown below:

No. of Bays	Power Gain
1	0.4611
2	0.9971
3	1.5588
4	2.1322
5	2.7154
6	3.3028
7	3.8935
8	4.4872
9	5.0826
10	5.6800
11	6.2783
12	6.8781
13	7.4785
14	8.0800

\*Omnidirectional, circularly polarized models without beam tilt and null fill, and with one wavelength vertical element spacing, per polarization.

**BATWING ANTENNAS**

**FOR HIGH POWER HORIZONTALLY POLARIZED VHF AND FM APPLICATIONS**



BATWING ANTENNA

**TYPICAL ELECTRICAL SPECIFICATIONS**

ELEVATION GAIN	Approximately 1.0 (per bay).
PEAK GAIN	Elevation gain * azimuth gain.
INPUT POWER RATING	47-88 MHz Band: Approximately 20 kW peak per bay; 87.5 - 108 MHz Band: Approximately 13 kW average per bay; 174 - 230 MHz Band: Approximately 12 kW peak per bay until limited by input connector.
INPUT VSWR	Visual carrier: 1:05:1; color subcarrier: 1:08:1; typical channel: 1:1:1 or better.
AZIMUTH PATTERN CIRCULARITY	±2 dB or better (omnidirectional).
POWER REQUIREMENTS FOR OPTIONAL DEICER	47-66 MHz Band: 3 kW per bay; 66-108 MHz Band: 2 kW per bay; 174-230 MHz Band: 1 kW per bay.

**TYPICAL MECHANICAL SPECIFICATIONS**

Model	Band	H Height (FT)	R.C. Rad. Center (FT)	S Shear (LB)	M Moment (FT)	W Weight (LB)
TAB-1L	47-66	29.0	18.75	1,410	16,700	1,850
TAB-4L	47-66	70.0	33.29	4,930	123,700	7,800
TAB-6L	47-66	105.0	51.21	8,470	317,100	16,800
TAB-1L	66-88	27.0	17.73	1,060	14,100	1,650
TAB-4L	66-88	59.0	27.88	3,880	86,000	5,800
TAB-6L	66-88	87.0	41.71	6,610	205,000	11,800
TAB-1M	87.5-108	14.0	5.0	610	3,700	750
TAB-4M	87.5-108	46.0	21.0	2,740	47,800	3,800
TAB-6M	87.5-108	68.0	32.0	4,480	117,500	7,500
TAB-2H	174-230	20.0	9.63	700	6,000	800
TAB-6H	174-230	41.25	19.17	1,900	28,250	3,000
TAB-12H	174-230	78.0	37.67	4,350	137,000	9,000

NOTES: Shear and moment indicated for 50 (flats) 33 (rounds) PSF per EIA-222C, no ice. Height includes 4 ft. lightning rods and excludes length of bury. R.C. - Radiation Center above base of antenna. C<sub>A</sub>A<sub>C</sub> per EIA-222E available upon request.

Specifications subject to change or revision.



**KEY BENEFITS**

- ▶ **Pattern characteristics:**
  - Provides omnidirectional pattern in the horizontal plane with typical circularity of ±2 dB or better.
  - Can be customized with notch diplexer and/or phasing equipment to provide peanut pattern.
  - Elevation plane patterns with beam tilt and null available for most special requirements. One through eight bays available for 47-108 MHz; One through twelve bays available for 174-230 MHz.
- ▶ **Wide bandwidth:**
  - Capable of transmitting two or more multiplexed signals from same channel group (VHF Low Band: 47 - 66, 66 - 88 MHz; FM: 87.5 - 108 MHz; VHF High Band: 174 - 230 MHz).
- ▶ **Mounting:**
  - Antenna normally top-mounted on tower top; smaller models may be side-mounted for standby operation.
- ▶ **High Power handling capability:**
  - 7/8" copper feedlines to individual elements.
  - Normally fed by two 3-1/8" 50 ohm transmission lines from low cost hybrid diplexer; other feedline arrangements available.
  - Antenna can be equipped with a single transmission line input to accept signal from a notch diplexer.

▶ **Rugged mechanical construction:**

- Corrosion-resistant components prevent mechanical and electrical degradation.
- Radiators solidly bolted to mast which is at ground potential for maximum lightning potential.
- Not severely affected by moderate icing because of inherently low feed-point impedance; optional electrical de-icers available for areas where severe icing occurs.

Transmitting Antennas

**DELTAWING ANTENNAS****UNLIMITED PATTERN CONTROL FOR DIRECTIONAL VHF, FM AND UHF APPLICATIONS****KEY BENEFITS****► Pattern characteristics:**

—Provides unlimited pattern control for directional applications.

—In addition to omnidirectional capabilities, offers wide variety of azimuth patterns using number of elements per face, power and phase division for achieving the pattern you need. Tower mounting versatility provides even greater radiation pattern shaping control.

—Two basic elements (COS, 3 around and COS<sup>2</sup>, 4 around) provide additional pattern control.

**► Wide bandwidth:**

—Allows antenna to transmit two or more multiplexed signals from same channel group (VHF Low Band: 47 - 66 MHz, 66 - 88 MHz; FM: 87.5 - 108 MHz; VHF High Band: 174 - 230 MHz; UHF: 470 - 860 MHz).

**► Power handling capability:**

—Designed for low to medium power ranges.

—New pressurized low power version featuring foam feed cables and sealed power dividers for applications 5 kW and lower is available. This model saves initial and operating expense of a dehydrator.

—Impedance matching accomplished by individual radiator adjustment and use of impedance transformers in power dividers. Individual panels optimized at factory for self and mutual impedances.

—After installation, VSWR is optimized by adjusting probe-type matchers built into the feed system.

**► Mounting:**

—Offers flexibility for side-mounting on existing towers. Ideal for stacked configurations. Towers can be planned to provide structural integrity needed to support an additional top-mount antenna.

**► Rugged mechanical construction:**

—Uses pair of Batwing-shaped radiating elements in panel configura-

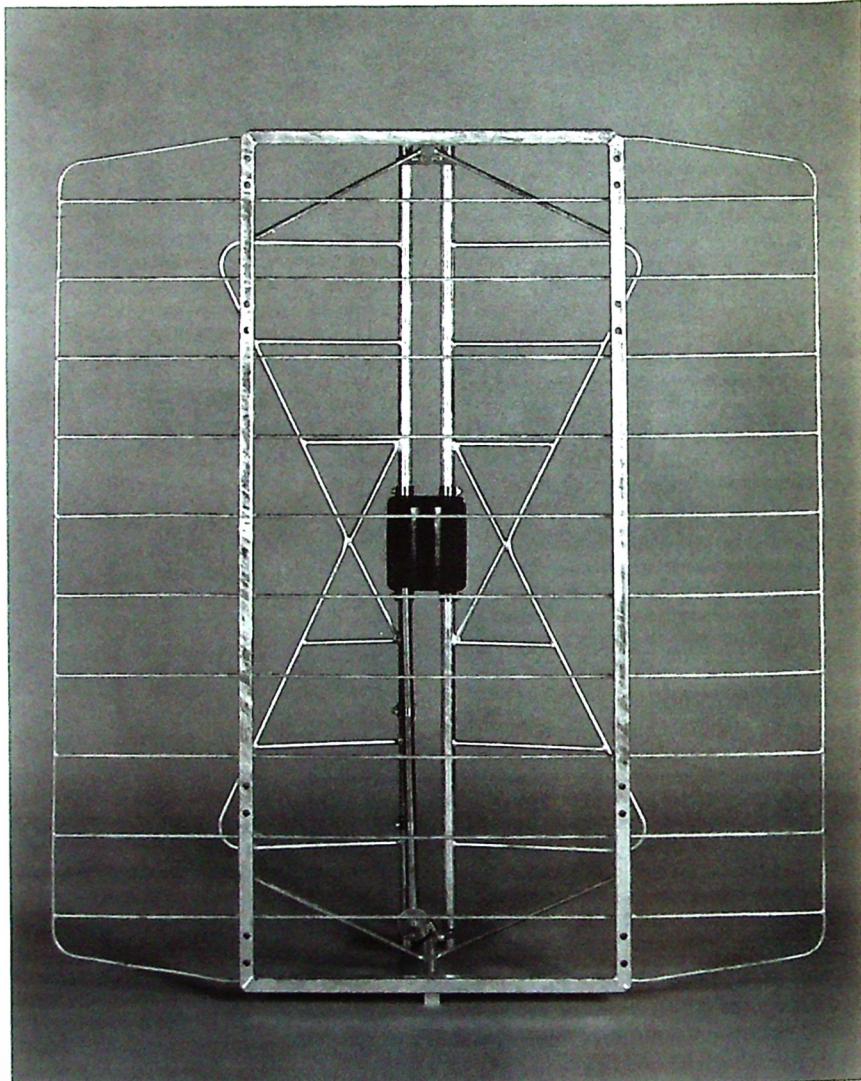

VHF DELTAWING

tion featuring 1/2 the feedpoints of an equivalent half wavelength-spaced dipole panel.

—Panel, approximately .7 wavelengths square, designed for minimum weight and windloading as well as optimum impedance and radiation performance.

—Corrosion-resistant components prevent mechanical and electrical degradation. Structural steel radiation elements and ground screen panels are hot-dip galvanized on VHF models. UHF models feature stainless steel construction.

—Each VHF panel is equipped with Feed Point Radomes for protection against ice build-up. UHF models feature full panel radomes. Radomes minimize VSWR increases under icing conditions; do not require AC power, and provide protection from environmental contamination and driving rains.

—Antenna not severely affected by moderate icing conditions; for environments where severe icing occurs, optional factory-installed electrical deicers recommended for VHF models.

## TYPICAL ELECTRICAL SPECIFICATIONS

**ELEVATION GAIN**

Approximately 1.1 (per bay); 2.2 per duplet panel.

**PEAK GAIN**

Elevation Gain \* Azimuth Gain.

**INPUT POWER RATING  
(PER PANEL)**

47 - 66 MHz Band  
66 - 88 MHz Band  
87.5 - 108 MHz Band  
174 - 230 MHz Band  
470 - 600 MHz Band  
572 - 730 MHz Band  
674 - 860 MHz Band

1/2" Harness

2.5 kW Peak  
2.2 kW Peak  
1.5 kW Average  
1.3 kW Peak  
0.9 kW Peak  
0.8 kW Peak  
0.7 kW Peak

7/8" Harness

8.0 kW Peak  
7.0 kW Peak  
4.5 kW Average  
4.0 kW Peak  
2.6 kW Peak  
2.3 kW Peak  
2.1 kW Peak

**TYPICAL INPUT VSWR AFTER  
FIELD OPTIMIZATION**

Visual Carrier: 1:05:1, Color Subcarrier: 1:08:1; Typical Channel: 1:1:1 or better.

**POWER REQUIREMENT  
FOR OPTIONAL DEICERS**

47 - 66 MHz Band: 1.5 kW per panel; 66 - 108 MHz Band: 1.0 kW per panel; 174 - 230 MHz Band: 0.5 kW per panel.

## TYPICAL MECHANICAL SPECIFICATIONS

INDIVIDUAL PANEL

Band	Panel Height (FT)	Bay To Bay Spacing (FT)	Shear (LB)	Weight (LB)
47-66 MHz Band	12.4	17.1	720	600
66-88 MHz Band	9.7	14.1	580	510
87.5-108 MHz Band	7.2	10.0	385	320
174-230 MHz Band	4.6	5.3	160	80
470-860 MHz Band	3.71	3.75	270	40
*For duplex (dual) panel:				
174-230 MHz Band	9.9	10.5	330	150

## APPROXIMATE ARRAY CALCULATIONS

Total Height = (# bays - 1) X bay to bay spacing + panel height

Radiation Center = total height/2

Weight = Individual panel weight X number of bays X panel per bay X 1.1 (for feed system)

Shear = Individual panel shear X number of bays X panel per bay X 1.1 (for feed system)

**NOTES:** Shear may be reduced for some configurations where shielding is significant.

Shear indicated for 50 (flat)/33 (rounds) PSF per EIA-222C, no ice.

Shear and weight exclude tower and support brackets.

C<sub>A</sub>C per EIA-222E available upon request.

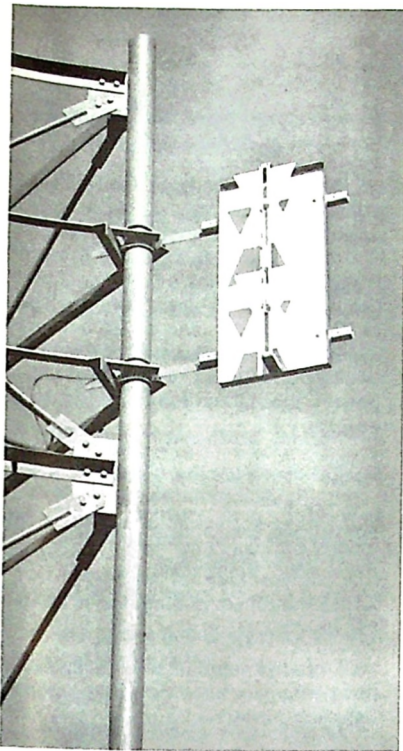

UHF DELTAWING

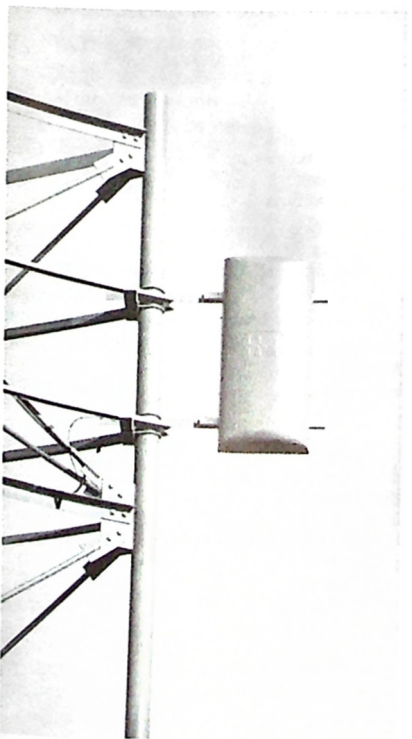

UHF DELTAWING WITH RADOME



# CIRCULARLY POLARIZED TAV ANTENNAS FOR HIGH POWER TOP-MOUNT VHF APPLICATIONS

## KEY BENEFITS

- ▶ **Pattern characteristics:**
  - Excellent axial ratio of <2 dB improves picture quality by reducing "ghosting" effect and/or increasing signal-to-noise ratios.
  - Excellent azimuth pattern circularity.
  - Elevation pattern contouring for beam tilt and null fill causes no degradation of the axial ratio.
- ▶ **High power handling capability:**
  - Antennas permit use of either single or dual transmission line.
  - Standard input for low band model are dual 3-1/8" 50 ohms connections; standard input for high band model is single 6-1/8" 50 ohm connection.
  - High power handling capability with ratings to 100 kW.
- ▶ **Mounting:**
  - Antenna is typically top mounted on tower. Antenna can be structurally designed to allow "stacked" arrangement minimizing azimuth pattern distortion for both antennas.
- ▶ **Rugged mechanical construction:**
  - Each bay consists of three crossed vee dipoles mounted at 120° intervals around a vertical mast.

—Standard fiberglass radome covers provide protection from moisture, ice and corrosion. Electrical de-icers are not required.

—All antenna masts are hot-dip galvanized and finish-painted before assembly. Stainless steel hardware is used for added corrosion protection.

—DC ground potential to each dipole element enhances antenna and transmitter lightning protection.

## TYPICAL AZIMUTHAL PATTERN

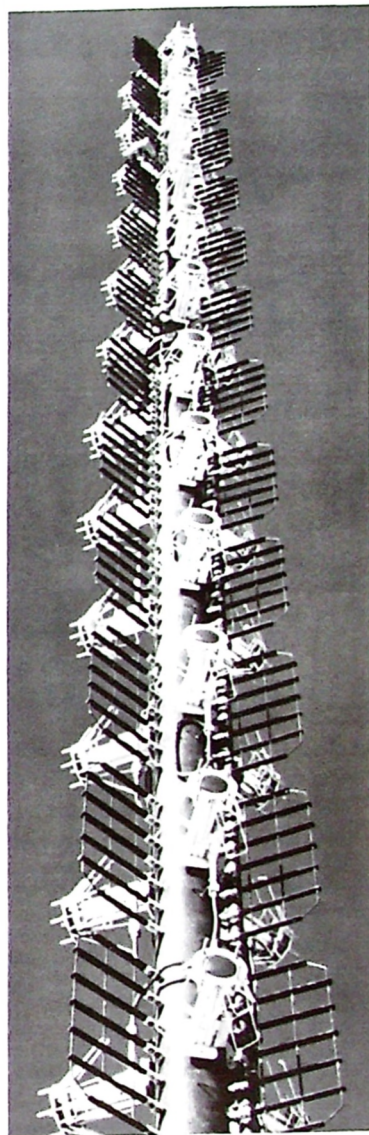
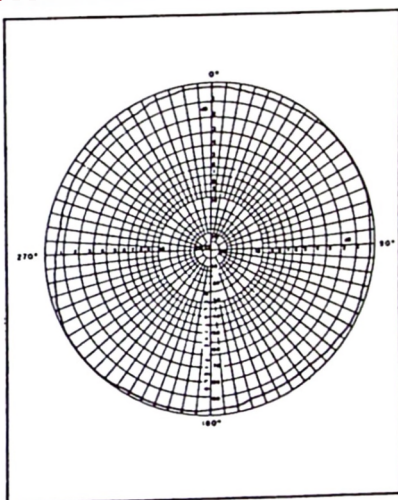

TAV ANTENNA

## TYPICAL ELECTRICAL SPECIFICATIONS

ELEVATION GAIN	Approximately .45 (per bay each polarization).
PEAK GAIN	Elevation Gain X Azimuth Gain.
INPUT POWER RATING	47-88 MHz Band: Approximately 15 kW peak per bay; 87.5-108 MHz Band: Approximately 10 kW average per bay; 174-230 MHz Band: Approximately 10 kW peak per bay until limited by input connector.
INPUT VSWR	Visual carrier: 1.05:1; Color Subcarrier: 1.08:1; Typical Channel: 1.1:1 or better.
AZIMUTH PATTERN CIRCULARITY	±2 dB or better (omnidirectional).

## TYPICAL MECHANICAL SPECIFICATIONS

Model	Band	H Height (FT)	R.C. Rad. Center (FT)	S Shear (LB)	M Moment (FT)	W Weight (LB)
TAV-6L	Ch 4	80.5	38.8	7,650	232,000	13,000
TAV-12H	Ch 10	63.7	29.8	4,760	142,000	8,100

NOTES: Shear and moment indicated for 50 (flats)/33 (rounds) PSF per EIA-222C, no ice. C<sub>A</sub>A<sub>C</sub> per EIA-222E available upon request.  
Height includes 4 foot lightning rods and excludes length of bury.  
R.C. - Radiation Center above base of antenna.  
All mechanical parameters vary in the number of bays and frequency. Contact Harris for specific data.

Transmitting Antennas

**WAVESTAR® UHF ANTENNAS**



TWS-30C WITH OPTIONAL WAVEGUIDE INPUT

**KEY BENEFITS**

**UHF Super Power TWS Series Waveguide Antennas Featuring Circular, Lunar and Rectangular Construction**

► **Pattern characteristics:**

- Optimum coverage with range of azimuth and elevation patterns to meet specific requirements.
- Omnidirectional, trilobe, cardioid and peanut patterns available as standard. Customized patterns available.
- May be customized for elliptical polarization.

► **High power handling capability:**

- Handles input powers exceeding 1000 kW; easily accommodates 280 kW transmitter for omnidirectional and 140 kW transmitter for directional applications.

► **Rugged mechanical construction:**

- Constructed entirely of waveguide for ultimate reliability; no inner conductors, bullets, insulators, end seals, sliding shorts or other coaxial components.

**High Power TWSC Series Coaxial Construction Antennas**

► **Pattern characteristics:**

- Optimum coverage with a wide range of azimuth and elevation patterns to meet specific requirements.
- Select from a wide range of standard and custom patterns.
- Elliptical polarized models available.

► **High power handling capability:**

- Models available up to 140 kW transmitter ratings.

► **Rugged mechanical construction:**

- Slotted structural coaxial construction with lower windloading than equivalent waveguide models.

**Medium Power TWSM Series Wavestar Coaxial Construction Antennas for Side Mounted Applications**

► **Pattern characteristics:**

- Optimum coverage with a wide range of azimuth and elevation patterns to meet specific requirements.
- Select from a wide range of standard and custom patterns.
- Elliptical and full circular polarized models available.

► **Medium power handling capabilities:**

- Models available up to 70 kW transmitter rating.

► **Lightweight mechanical construction:**

- Slotted coaxial construction for side mounted applications.

**All Wavestar Models**

- Corrosion-resistant components prevent mechanical and electrical degradation.
- Optimized for extremely low VSWR, designed to withstand minimum of 50 PSF winds per EIA 222C. C<sub>A</sub>A<sub>C</sub> per EIA 222E available upon request.
- All element components are at DC ground potential for top lightning protection.
- Supplied with full-pressurized radome or low windload slot covers to match environmental conditions. For areas that experience extreme icing, special radome coatings are available as well as electrical deicers for slot cover models.
- Full range testing assures patterns and impedance performance in the field.
- Standard input, 6-1/8 - 75 ohm. Larger coax waveguide inputs available.

**TYPICAL ELECTRICAL SPECIFICATIONS**

<b>ELEVATION GAIN</b>	Available from 4 to 35.
<b>PEAK GAIN</b>	Elevation Gain x Azimuth Gain.
<b>INPUT POWER RATING</b>	Limited by input connectors and model, typically 30 - 280 kW.
<b>INPUT VSWR</b>	Visual Carrier: 1.05:1; Color Subcarrier: 1.08:1; Channel: 1.1:1 or better.



## TYPICAL MECHANICAL SPECIFICATIONS

Model	Channel	H Height (FT)	R.C. Rad. Center (FT)	S Shear (LB)	M Moment (LB)	W Weight (LB)	Ice Protection
TTWS-30	14	70.9	33.7	5,890	200,500	9,300	Radome
TTWC-30	69	44.2	20.6	2,660	55,600	4,000	Radome
TTWS-25	14	58.4	27.5	4,800	133,500	7,800	Radome
TTWS-25	69	37.5	17.2	2,230	39,200	3,500	Radome
TTWS-30C	14	74.8	35.3	3,240	117,500	11,300	Slot Cover
TTWS-30C	69	46.3	21.4	1,350	30,400	4,200	Slot Cover
TTWS-25C	14	63.0	29.5	2,720	83,400	9,500	Slot Cover
TTWS-25C	69	39.3	17.6	1,140	22,100	3,500	Slot Cover
TTWSC-30	14	71.1	33.4	5,260	179,300	12,000	Radome
TTWSC-30	69	44.2	20.2	2,200	46,000	4,700	Radome
TTWSC-25	14	60.1	27.9	4,420	126,400	8,700	Radome
TTWSC-25	69	37.8	17.0	1,870	33,100	3,500	Radome
TTWSC-20	14	48.9	22.5	3,560	82,400	5,000	Radome
TTWSC-20	69	31.0	14.0	1,570	22,000	2,500	Radome
TTWSM-30	14	71.1	33.4	2,700	Side Mounted	1,800	Radome
TTWSM-30	69	44.2	20.2	1,600	Side Mounted	1,100	Radome
TTWSM-25	14	60.1	27.9	2,250	Side Mounted	1,500	Radome
TTWSM-25	69	37.8	17.0	1,350	Side Mounted	950	Radome
TTWSM-20	14	48.9	22.5	1,800	Side Mounted	1,250	Radome
TTWSM-20	69	31.0	14.0	1,100	Side Mounted	800	Radome

**NOTES:** Shear and moment indicated for 50 (flats)/33 (rounds) PSF per EIA-222C, no ice.  $C_x A_c$  per EIA-222E available upon request.  
 Height includes 4 foot lightning rods.  
 R.C. - Radiation Center above base of antenna. For other channels, calculate new height,  $R.C. = (HT - 4)/2$ .  
 Linear interpolation may be used to calculate approximate rate H (Height) shear and weight.  
 For approximate moment at other channels, calculate new shear then:  $moment = 155 + 100 \times (HT - 4) + (shear \cdot 100) \times (HT - 4)/2$ .



### Broadcasting's Most Rigorous Antenna Testing

After final assembly, every Harris antenna undergoes extensive testing to verify that customer specifications are fully met. Testing includes impedance optimization, cylindrical near-field pattern testing and far-field pattern measurement testing.

Harris Allied's 40-acre antenna assembly and test facility is ideally situated on a 230-foot bluff near the Mississippi River. That area, with transmitters located in the Mississippi bottom lands, provides testing conditions which approximate the "free space" situation of an installed antenna. The range includes areas for near-field and far-field testing. Computerized control and monitoring systems are used to provide accurate and repeatable results.

For horizontal and vertical pattern testing, the antenna is positioned across support towers on a turntable with a 90 foot concrete base. A beam rotates a full 360 degrees, examining the antenna from every angle. For horizontal pattern testing and impedance matching, the antenna may be positioned upright on a vertical turntable at a height of 35 feet to provide isolation from ground effects. During testing, the antenna acts as a receiving unit which then transmits signal readings to computerized test equipment. This test equipment translates readings into horizontal and vertical patterns which are plotted, producing a drawing of actual field strength.

No Harris-manufactured and tested antenna is shipped unless pattern characteristics are verified to fully meet customer specifications. Harris Allied's unmatched combination of technical expertise, test procedures, facilities and test equipment offer full assurance that when you purchase a Harris antenna, you'll get the performance and pattern you expect.

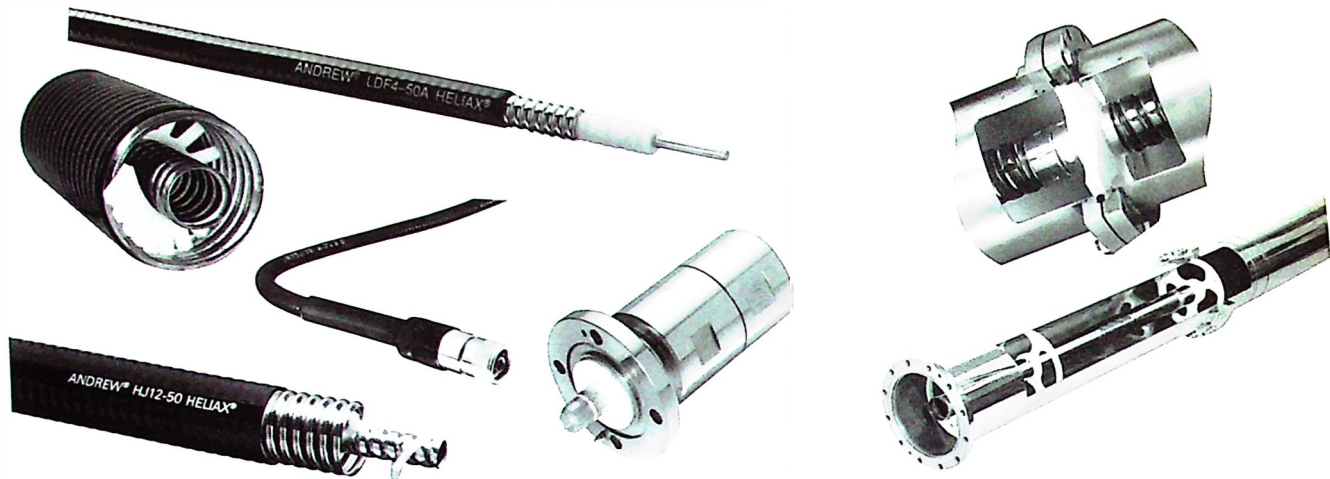

### HeliAx® Coaxial Cable

For more than 50 years, Andrew has offered a comprehensive line of broadcast products. These include both foam and air dielectric HELIAX® flexible coaxial cables, pressurization equipment, installation accessories, as well as standard and premium rigid transmission lines and components.

HELIAX coaxial cable is supplied in long continuous lengths which simplifies and lowers installation cost. The low attenuation and excellent heat transfer properties of HELIAX cables combined with temperature stabilized dielectric materials, results in safe long term operation at high average power levels. Andrew standard coaxial transmission line has PTFE dielectric peg insulators and silver soldered flanges. Fully compatible with both EIA standard RS-225 and IEC recommendations, standard rigid line flanges and inner connectors do not require adaptors or special sections. **For detailed information on the entire Andrew line of products call Harris Allied today.**

### HR Line™ Rigid Line Cable

Andrew's new HR Line™ premium rigid line provides increased reliability by eliminating sliding inner contacts or "bullets." Thermal expansion and contraction are compensated for through a continuously corrugated inner conductor. HR Line maintains conventional rigid line outer conductor and flange configurations, but uses a patented bolted inner joint at the flange. Compared to conventional rigid line, HR Line offers long term, trouble-free operation. HR Line is available in 6½" size with either 50 or 75 ohm impedance.

The Andrew 2¼" HJ12-50 HELIAX air-dielectric coaxial cable delivers the low attenuation you expect from 3" cable while it's easier to install, more cost effective and provides lower windloading! Only Andrew offers this new dimension in system flexibility! Low VSWR versions of the HJ12-50 and the complete line of HELIAX connectors and accessories are also available. **For detailed information on the entire Andrew line of products call Harris Allied today.**



### EASIX™ Cable Cutting Tool

Andrew's EASIX™ eliminates hacksawing cable while precisely and consistently cutting through the outer jacket. The clean cut makes flaring easier than ever. The EASIX blade depth makes it impossible to cut the inner conductor. EASIX kits consisting of tool, instruction sheet and 5 extra blades are available for FSJ1 series, FSJ4 series, LDF4 series and LDF5 series HELIAX cable.

### DryLine™ Dehydrator

The Andrew DryLine™ dehydrator is the industry's most advanced system for pressurizing transmission lines. DryLine sets new standards for drying performance, reliability and convenience. DryLine meets UL/CSA requirements and is warranted for three years.

Patented membrane separation drying technology gives you 55,000 hours Mean Time Between Failure — double the industry standard. The system is built into a convenient two-chassis package that includes all components needed for pressurization, and can be mounted to a rack, cabinet, wall or floor without any additional hardware. The DryLine is carefully balanced and isolated to minimize noise and vibration, so it can be mounted directly into radio equipment racks. DryLine features programmable controls and monitors with LCD readouts.

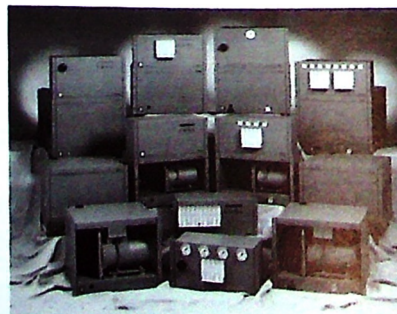



ANDREW LDF6-50 HELIAX®

# SPECIFY HELIAX®

## For Consistent Quality and Performance

When you specify HELIAX coaxial cable, made only by Andrew, you're buying more than just cable. You're buying quality and performance that will save you money over the life of your system investment. HELIAX is:

**Reliable...Durable...Weatherproof**

And you get the peace of mind that comes with knowing your system is utilizing the best RF transmission line in the business. For foam or air cables, specify HELIAX for consistent quality and performance.



**ANDREW**



8572  
Dummy Load

### 8572 Dummy Load

Model 8572 is a well-matched termination for 50 ohm rigid line systems to 25,000 watts for testing and alignment of transmitters. The RF power is dissipated in a large number of rugged parallel/series connected resistor elements, which not only provide an extensive total surface for heat transfer, but assure that the load is not rendered inoperative due to failure of one or two of the elements. As a dry load, Model 8572 is nearly maintenance-free.

### A Series Rigid Line Wattmeters

Known for high accuracy wattmeters, Bird provides High Power, Rigid Line Wattmeters for 1 $\frac{1}{8}$ "", 3 $\frac{1}{8}$ "", 4 $\frac{1}{16}$ " and 6 $\frac{1}{8}$ " Lines. Each Bird High Power Rigid Line THRULINE<sup>®</sup> RF Directional Wattmeter is comprised of a Line Section and a direct reading 3 scale meter housed in a convenient carrying case. Bird offers ThruLine<sup>®</sup> RF Directional wattmeters, RF load resistors and Wattcher<sup>®</sup> protection systems.

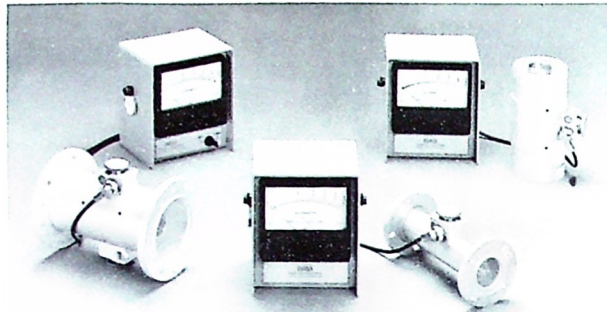

"A" Series Rigid Line Wattmeters

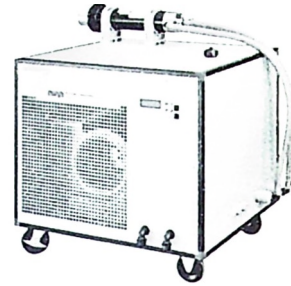

ModuloLoad<sup>®</sup> System

### 8660/8670 Series ModuloLoad<sup>®</sup> Systems

The 8660 and 8670 Series ModuloLoad<sup>®</sup> RF Load Systems incorporate the latest advances in RF load resistor design. The result is a much improved series of self-contained, liquid-cooled terminations that have increased reliability and are easier to use. ModuloLoad<sup>®</sup> resistors are ideal terminations for all types of 50 ohm RF transmission systems. Models 8660 and 8670 are conservatively rated at 15 kW and 30 kW and, depending upon ambient temperature levels, can dissipate up to 20 kW (8660) or 50 kW (8670). Installation is made easy by the ModuloLoad's new flexible design. The load resistor is normally mounted to the outside of the heat exchanger in any one of three configurations. For even greater flexibility, the load resistor can be remote mounted up to 30 feet from the heat exchanger. This permits the load resistor to be installed in one room while the heat exchanger is located in a separate area. The unit's modular heat exchanger is easily adapted to a building's standard ductwork.

## BURK TECHNOLOGY

### SCA-2 Subcarrier Receiver

Burk Technology's SCA-2 Subcarrier Receiver permits the economy of wireless telemetry return. The SCA-2 receives and demodulates subcarrier telemetry information. When ordering please specify main carrier and subcarrier frequencies. Need to supply your own external antenna.

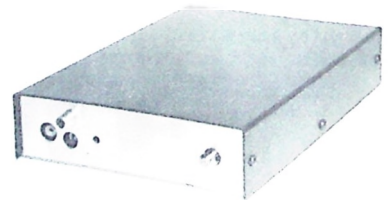

## COMARK

### Rigid Coaxial Transmission Line

Comark rigid coaxial transmission line provides outstanding features such as constant impedance, high power capacity and low insertion loss. Sizes to 8 $\frac{1}{16}$ " Heliarc-welded flanges and wrist band bullet construction 3 $\frac{1}{8}$ " and above.

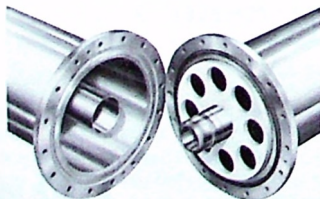

### Coaxial Switches

Low VSWR and low insertion loss combined with maximum isolation make Comark coaxial switches the ideal instrument for routing RF, especially in remote control applications. The positive action switching solenoid may be remotely controlled or overridden manually.

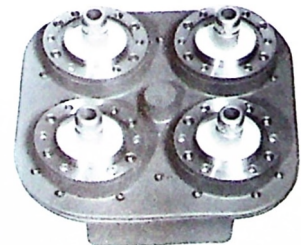

## CRL

### SiCA 300B SCA Generator

The SCA 300B limiter/subcarrier generator is an advanced concept in SCA generation techniques. The frequency-locked digital design ensures superior carrier frequency stability, while providing linear modulation characteristics. It is designed to handle any type of data or audio application.



## DELTA

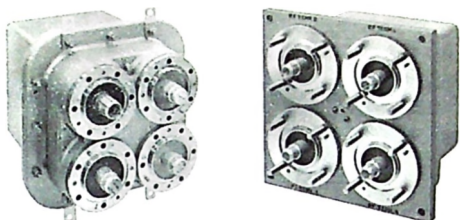

### 6700 Series Coaxial Transfer Switches

The Delta 6700 Series of coaxial transfer switches provides the engineer with the capability to switch between transmitters, antennas, or dummy loads with a minimum of off-the-air-time. Both models can be operated by remote control or manually. Remote operation can be achieved using either 120V or 220/240V, 50/60 Hz. The transfer switch is fully interlocked with two isolated interlock circuits that duplicate the RF path exactly. The 6730/6732E is a 1 1/4 inch switch. The 6740B/6742B is a 3 1/4 inch switch and may be pressurized up to 16 lb./sq. in. A gas barrier is built into each terminal, and an air inlet port is also provided in the 6740B/6742B model.



### OIB-1/OIB-3 Operating Impedance Bridge

Delta OIB operating impedance bridges measure the operating impedance of the individual radiators, networks, transmission line sections and common point of directional antenna systems while they are functioning under normal power.

### ASE-2 AM Stereo Exciter

The Delta ASE-2 AM Stereo Exciter will convert an AM mono station to a competitive, better sounding AM stereo station. Operating frequency is crystal controlled for maximum frequency stability and minimum phase noise. The ASE-2 generates an audio drive signal for the transmitter's modulator and a TTL logic level RF drive signal

### ASE-1 AM Stereo Exciter ASM-1 Modulation Monitor

AM stereo without compromise. The ASE-1 AM stereo exciter and ASM-1 modulation monitor provide a C-Quam™ quadrature modulated stereo signal featuring low distortion and channel separation greater than 35 dB throughout the audio spectrum. The ASE-1 exciter circuitry includes all required processing features. Limiters are provided to prevent excessive positive and negative modulation. A blend processor makes high single channel modulation possible by blending a little of each channel with the other. Pre-emphasis is not required.

### CPB-1

The CPB-1 is designed for permanent installation in existing phase equipment to provide an accurate indication of the common point impedance. The CPB-1 will handle common point powers of up to 5 kW with 100% modulation. The CPB-1A is designed for powers up to 50 kW.

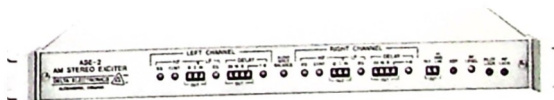

ASE-2 AM Stereo Exciter

to replace the transmitter's crystal oscillator output. Output is C-QUAM® signal (Compatible Quadrature Amplitude Modulated).

## DURO-TEST

### Duro-Test Bulbs

Dependable, long-lasting, quick-to-see bulbs from Duro-Test are the best where there are potential traffic hazards. Models 682, 683 and 684 sold in packages of 2. Model 424-A-21 sold only in packages of six.

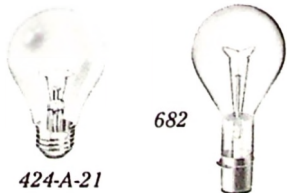

## ELECTRONIC RESEARCH

### Isolation Transformers

ERI isolation transformers couple the FM power across the base insulator of a transmitting tower used jointly for AM or FM antennas without introducing objectionable mismatch into the FM feed line. Captive bullets in and out. 10, 25, 40 & 50 kW sizes.



Transmitting Accessories

Certain products not available in some areas.

HARRIS ALLIED

## CABLEWAVE



*Coaxial Transmission Line*

*Flexwell*

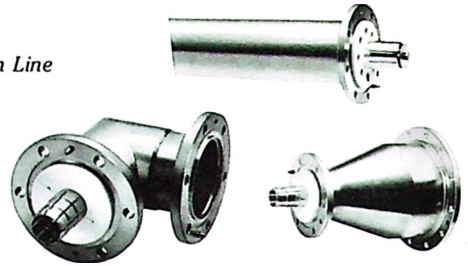

*Rigid Line*

### Flexwell Coaxial Cables

Cablewave Systems semi-flexible FLEXWELL coaxial cables are used in electronics and communications systems operating from VLF through the microwave frequency bands. Since each basic cable construction offers specific advantages, the company manufactures both smooth wall aluminum and corrugated copper coaxial cables in foam and air dielectric. This allows the user engineer to consider technical and economic factors for each type, and select the best construction for his requirements. Cables are cut to length and connectors factory attached upon request.

### Rigid Coaxial Transmission Line

Rigid coaxial transmission line is fabricated from high conductivity hard-drawn copper tubing with precision machined, pin-type, Teflon dielectric insulators. The standard 50 ohm line is offered in sizes from 7/8" through 6 1/8". The EIA bolt type flanges and inner connectors are compatible with EIA standards, US MIL specifications, and international IEC recommendations. Aluminum outer conductor 50 ohm and copper 75 ohm lines are available on special order. Harris Allied carries the complete Cablewave line including connectors. Further information on Cablewave's entire line is available.

## DIELECTRIC



*Information on Dielectric's entire line is available through Harris Allied.*

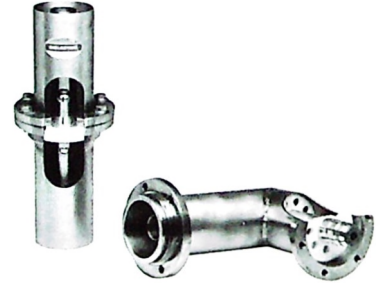

### DCR-C FM Antennas

The DCR-C, Dielectric's most popular FM antenna is circularly polarized with a power rating of 10 kW per bay, and is available in stacked arrays of up to 16 sections with an input power rating of 40 kW. The antenna is of heavy duty stainless steel construction for high reliability and long life. Radomes, electrical deicers, beam tilt and null fill are also optional. For custom directional applications, the DCR-C is an ideal solution.

### Rigid Coaxial Transmission Line

For over 35 years Dielectric has supplied rigid coaxial components worldwide. Rigid coaxial line offers benefits of high power handling and best efficiencies. Dielectric's quality differences include heliarc welded flanges, thick wall elbows, disc type inner conductor insulators and time proven expansion compensation. In standard sizes from 7/8" up through 9 3/16", custom components are also available.



### 50000 Series RF Switches

Dielectric's 50000 Series are motorized blade type (with silver plated contacts) coaxial SPDT or 4 port transfer switches, 7/8" through 6 1/8". Reliable design and construction allow as many as 100,000 cycles without failure. Isolation exceeding 60 dB is typical. Switches are equipped with a visual position indicator and manual override. Terminations are standard EIA fixed flanges.

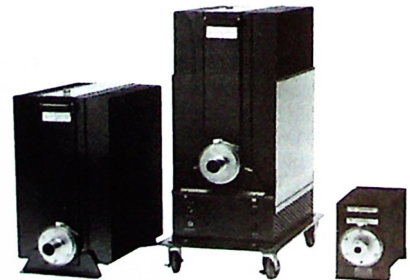

### Terminating RF Loads

Dielectric's complete line of terminating loads and calorimeter measuring devices include 5 to 150 watt dry loads, 600 watt to 10 kilowatt oil filled loads, 25 to 100 kW water/heat exchanger loads, and calorimetric measuring devices adaptable to existing systems. The 4000 Series Dry loads are normally available for same day shipment.

# FLEXWELL® RF & Microwave Transmission Line Products

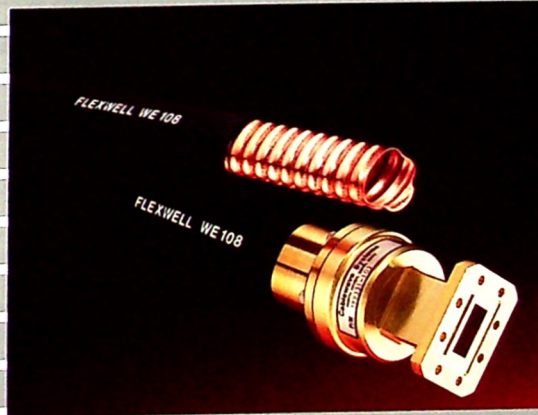
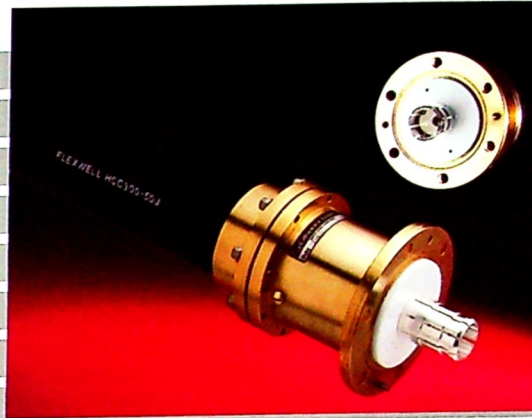
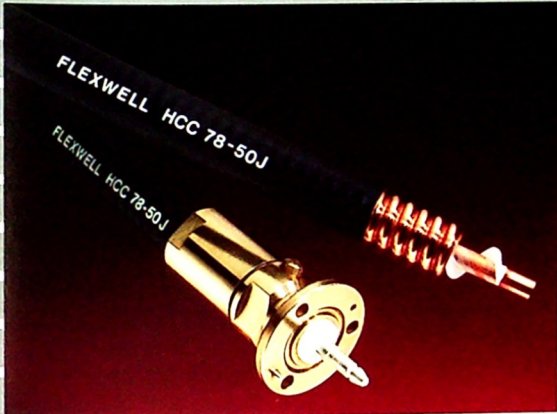

As partners in total quality,  
Cablewave Systems is committed  
to delivering the highest quality  
RF products available.  
ISO 9001 CERTIFIED



**Radio Frequency  
Systems, Inc.**  
Cablewave Systems Division



EDH-3W



EDH-3R

**EDH-3W Air Dehydrator**

The EDH-3W is a quiet, low cost, manually regenerated, dehydrator for pressurizing small volume L through Ku band waveguide and coax. Features include: simple installation, convenient drying agent replacement and microprocessor control. The EDH-3W dehydrator can be rack or wall-mounted. The desiccant canister was placed on the front to allow manual regeneration without removing the dehydrator from the rack. Standard pressure: 0.5 psig. The **EDH-3R Dehydrator** has identical benefits and features as the EDH-3W but with a rack-mount front panel for aesthetic appearance.



ADH-2COM

**ADH-2COM Dehydrator**

The ADH-2COM is a rack-mountable (optional weather proof box) automatic dehydrator for the pressurization of waveguide, feed horns and air-dielectric coaxial cable. A remote communications port (RS-422) complements the local summary alarm relay on the rear panel. The ADH-2COM features a protocol and interface that fully comply with the requirements of Scientific-Atlanta's SABUS. Standard pressure is a precise 0.5 PSI for the protection of waveguide windows. Quiet operation, low vibration level, low heat, digital display and malfunction alarm are some of the benefits and features of the ADH-2COM.

**GORMAN•REDLICH**



**CEB EBS Encoder/Decoder**

The Gorman•Redlich Model CEB Encoder-Decoder is a complete two frequency EBS system which meets F.C.C. requirements. The Encoder counts down the 3.9 MHz crystal oscillator frequency to generate a 960 Hz and 853 Hz tone which make up the attention signal. The Decoder portion detects the presence of the EBS attention signal at the output of the monitor receiver. Available in Stereo.

**ELECTRO IMPULSE**

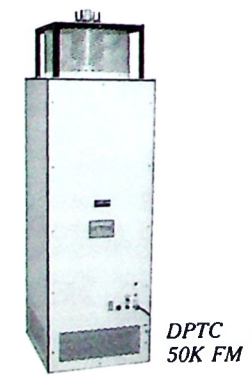

DPTC  
50K FM



DPTC  
10K FM

**Air Cooled Loads**

Electro Impulse developed the dry, forced air cooled loads for use up through FM frequencies. ELI offers RF coaxial loads with oil dielectric, twin line loads in a balanced input configuration, coaxial water loads, dry balun calorimeters, automatic test equipment, high power RF attenuators, RF power meters, in-line directional wattmeters and special cooling systems.

**HARRIS**



**AMS-G1 C-QUAM® AM Stereo Exciter**

The Harris AMS-G1 uses the latest technology available in C-QUAM® AM Stereo exciters to provide optimum AM stereo performance from Harris' DX, SX and solid state Gates line transmitters. The AMS-G1 comes self-contained in its own compact rack-mounted cabinet and accommodates all international requirements for channel spacing and is rear panel selectable 100,120, 220 or 240 volts, AC, 50 or 60 Hz.

New DX and Gates transmitters can be purchased with the AMS-G1 complete and ready to broadcast. The AMS-G1 can also be added to existing Harris solid state AM transmitters to get optimum AM stereo performance. Please check with Harris Allied technical support for other model transmitters.



## Phasemaster® T-Series Phase Converters

The Phasemasters® T-Series rotary phase converter is designed and engineered for use with all types of radio transmitters for the conversion of single phase power to 3-phase in locations which are not serviced by 3-phase lines. A Phasemaster can be installed for a fraction of the cost of installing utility supplied 3-phase power. Also available for open Delta circuits.

• Increase Transmitter Siting Options • Voltage regulated within 2-5% of primary electrical supply • Buffers line transients • Protects against effects of modulation peaks in AM transmitters.



# KINTRONICS

## FMC Series Isocouplers

Kintronic's FMC Series isocouplers at the base of an AM tower permit the installation of an FM antenna and connecting transmission line on the tower without requiring insulation and tuning of the transmission line. Since the shunting capacity of these units across the base insulator of the AM tower is less than 150 pf, the effect on the base input

impedance of the tower will be negligible for most single radiators or directional elements. 9 units available from 100 watts through 30 kilowatts.

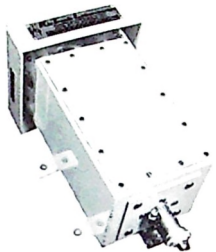

## LTU Series AM Couplers

In general these AM couplers (antenna tuning units) are located near the base of the tower. Each unit is custom designed to provide coupling between the actual transmission line and the antenna to be used. A full "T" network is utilized with components conservatively rated to provide long life under 125% modulation conditions and a range of impedance tuning to meet any normal deviation in field installation conditions. Includes weather-proof housing. Four models available 1300 watts to 55 kilowatts.

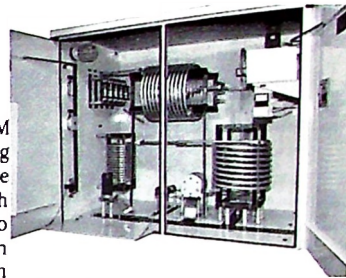

# KOHLER

## Fast Response II™

The Kohler Fast Response II™ Engine Generator System represents a highly refined second generation of the patented Fast Response™ design, offering these standard performance features: Instant response to load change, sustained short circuit capability, superior motor starting performance. Kohler Fast Response II™ is the first engine generator system to incorporate the reliability and efficiency of advanced microcomputer logic. The Kohler Microcomputer Decision Maker™ executes instruction in *microseconds* and is immune to false input.

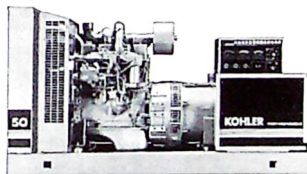

50 KW Fast Response II™

## R-Series™ Generator

R-Series™ generator sets above 10 KW provide many of the features of the Fast Response models including voltage regulation with  $\pm 2\%$ , and a broad range of voltage combinations including 347/600. Voltages from 120/240 through 277/480 are field reconnectable. The exclusive Kohler solid state volts per-hertz regulator has three phase sensing. The standard controller is a relay model with a meter box option. An optional solid state controller has a hospital lamp group to meet NFPA-76A.

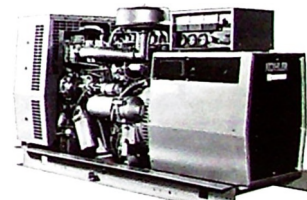

22.5 KW Gasoline

*Kohler power generators are available in single and 3-phase models with power ranges from 5 KW to 1000 KW.*

## TR-Series™ 300 KW to 1000 KW Power Generator

Diesel power with your choice of cooling, fuel system and exhaust system options. This series equipped with Kohler's Decision Maker solid state controller for full monitoring instrumentation, automatic protection features and accessories including small and large storage tanks and auto transfer. Engines for this series are supplied by Cummins. All are turbocharged and the majority are also after-cooled. With isochronous governors as standard equipment, steady-state frequency regulation from no load to full load is  $\pm .25\%$ .

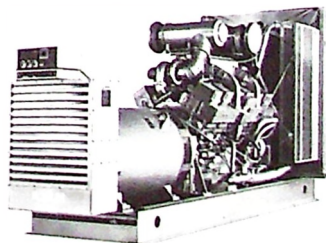

750 KW Diesel Brushless

## MARTI

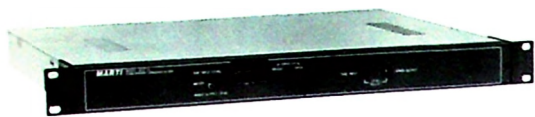

### SCD-10 Subcarrier Demodulator

The SCD-10 subcarrier demodulator is designed for use with the SCG-10 subcarrier generator to provide a high quality subcarrier channel on a microwave link (STL) or FM station. A wide range of options make this equipment flexible and versatile. 1 3/4"Hx19"Wx12"D. Unit weight: 4.5 lbs.



### SCG-10 Subcarrier Generator

The Marti SCG-10 subcarrier generator is designed to operate in SCA service with an FM broadcast transmitter or, with a SCD-10, to form a subcarrier link on a microwave (STL) system. Audio processing options include selectable pre-emphasis of zero, 75, 150 or 225 microseconds. Low pass audio filters of 3kHz, 5kHz or 7.5kHz are available. 4.5 lbs.

## MICRO COMMUNICATIONS

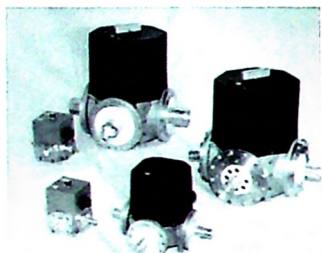

### Coaxial Transfer Switches

Micro Communications offers coaxial transfer switches in power levels to suit most needs. MCI also produces complete RF systems and rectangular and circular waveguide transmission line systems. Combiners, multi channel TV and FV combiners, diplexers, filters, directional couplers, loads, hybrids and switching systems are also available. These systems are available in a broad range covering VHF, UHF, LPTV, FM, MDS and ITFS.

## MICROWAVE FILTER

### Harmonic Low-pass Filters

Microwave Filter offers an entire line of harmonic low-pass filters for FM broadcast that don't cost a fortune. Wattages range from 500-30,000. Model 7123-500 watts, N connectors, 5.85" max. length; 6692-1000 watts, N connectors, 11.04" max. length; 7131-1,500 watts, 7/8" EIA, 16.938" max. length; 6612-6000 watts, 1 1/8" EIA, 75" max. length; 6516-30,000 watts, 3 3/8" EIA, 72" max. length.

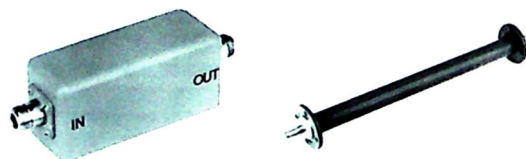

## MODULATION SCIENCES



### Sidekick SCA Generator

The Sidekick from Modulation Sciences combines into one package all the functions needed to add a second audio program channel

to a television station. A sync lockable subcarrier generator, dbx noise reduction encoding, audio processing and a peak deviation meter in one box. The audio processing portion of the Sidekick is designed for subcarrier modulation and provides maximum intelligibility of dialogue and the best fidelity of music while delivering the greatest possible signal-to-noise. Has a 50Hz to 10kHz audio bandwidth. Includes rack-mounts.

## MOSELEY



### SCD-8 Subcarrier Demodulator

The SCD-8 subcarrier demodulator with automatic muting and front-panel peak-deviation meter, includes self-contained power supply. Available for operation at any standard frequency in the 26-185 kHz spectrum. Specify operating frequency when ordering. Shipping weight: 10.5 lbs.



### SCG-8 Subcarrier Generator

The Moseley SCG-8 subcarrier generator with automatic muting and front-panel peak-deviation meter, includes self-contained power supply. Available for operation at any standard frequency in the 26-185 kHz spectrum. Specify operating frequency when ordering. Shipping weight: 10.5 lbs.

## M-RF ELECTRONICS



### M-RF Isocoupler

The M-RF Isocoupler facilitates the connection of an STL, RPL or TRL transmitter or receiver to a mounted antenna or an underground standard AM broadcast tower. The M-RF is designed for use on quarter-wave towers and should be able to handle instantaneous peaks in excess of 15,000 volts. It can safely handle 100 watts of power.

## MYAT

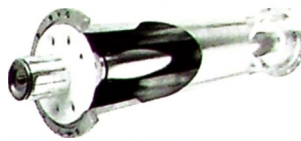

### Rigid Coaxial Transmission Line

If you're looking for superior rigid coaxial transmission line and RF components, start by calling Harris Allied about Myat products. TV and radio RF engineers routinely specify Myat products due to a high-quality performance. Call today.

## ONEAC

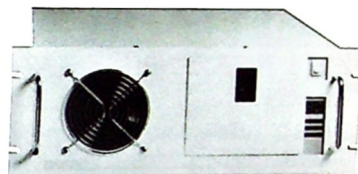

Rack-mount Model



Floor Model

### Uninterruptible Power Systems (UPS)

Oneac offers a wide range of UPS (Uninterruptible Power Systems) up to 2 kVA in 19" rack-mount (900, 1300 and 1850 VA) and floor model (400, 600, 900, 1300 and 1850 VA) versions. These units are designed for high reliability in mission-critical applications at cost-effective prices. All units offer full transformer power conditioning, hot-swappable battery packs, and advanced diagnostics to alert if UPS needs attention.

## PI-ROD

### Pi-Rod Towers

Pi-Rod towers are solid rod, all-welded construction which provides greatest strength with minimum surface exposure to wind and icing conditions. Slim line design offers minimized air resistance. Computerized analysis of loading factors for structure conformity meets and exceeds customer specifications. Working with this data, licensed professional engineers review your specific requirements and determine the ultimate solution. Pi-Rod designs systems to meet critical space limitations, with 50% and small guy radii available.

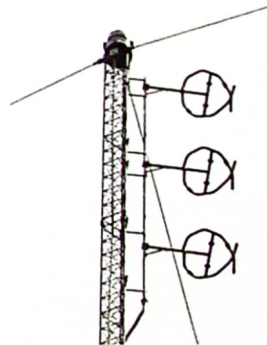

## TFT



### EIS 911/912 Emergency Information System

TFT's EIS 911 Emergency Information System Decoder and the 912 EIS Encoder use the broadcast station's full power to communicate alerting and emergency information via all media: AM, FM, TV broadcast and cable. Decoder scans 4 inputs for WRSAME code for display to operator. Encoder generates emergency codes in WRSAME format via RS-232C port to 911.

(As of press time, EIS 911/912 had not been FCC approved)



### 886/887 AM/FM EBS System

Models 886 and 887 Emergency Broadcast System (EBS) encoder/decoder systems are designed for broadcasters to meet FCC rules and regulations. Both feature DIP-switch selectable timing for attention tone generation and detection. The AM receiver, 886, is tunable across the AM broadcast band. The FM receiver, 887, is a high-performance, digitally tunable receiver. To assist with compliance, there are separate 2-digit LED displays on the front panels.

**GORMAN-REDLICH**

**CRW Weather Receiver**

The CRW is a highly sensitive (0.28 mVolt) and selective receiver for the National Weather Service (NWS) transmissions. False alarms and missed alerts are eliminated by high Q, individually tuned active filters. When the 1050 Hz Emergency Alert tone is transmitted for at least four seconds, the receiver will de-mute the front speaker and flash a front panel LED. It will also close relay contacts on the rear panel, allowing automatic external recording of messages. Continuous audio (600 ohms) is available from the rear panel also. Up to three of the seven frequencies used by the NWS can be supplied and are switch selectable and crystal controlled. A 50 ohm antenna jack for your external antenna ensures good reception.

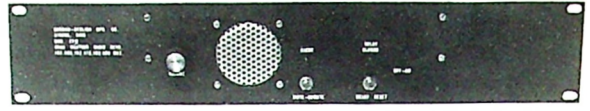

**MTS**

**2074 NOAA National Weather Service Receiver**

The MTS 2074 is a single rack space receiver tuned to a specified National Weather Service (NWS) frequency. It has a front panel speaker, carrier present LED and alarm LED, in addition to an alarm reset and monitor on/off switches. Through the rear panel connectors there is a 600 ohm balanced audio that is always present, alarm relay and carrier loss indication. There is also an input to mute the speaker that can be connected to the studio speaker muting logic. The system responds to the NWS 1050 Hz Emergency Alert tone with a time delay to prevent false triggering.



**COMPUTEMP**

**Computemp 5 Temperature Monitor**

The Computemp 5 is your station's source of temperature information. It features continuously-alternating readouts displaying both the time of day and temperatures at each location you are monitoring. The Computemp monitors temperatures at two locations. It provides updated temperature information constantly. The unique memory function keeps track of daily temperature extremes and the temperature alarm alerts you to critical temperature changes. Computemp 5 features indoor & outdoor temperature, remote temperatures, temperature history, temperature alarm and clock & time alarm. You may choose either F or C display. Dimensions: 2 3/4"H x 6 1/2"W x 4 1/2"D. Shipping weight: 3 lbs. Comes standard with a 6' and a 30' probe.



**Every Link In Your Air Chain Can Be Supplied By Harris Allied!**

*From the microphone through the antenna. No one provides the quantity or quality of services and products as Harris Allied.*

**In the USA call 800-622-0022**

**See Pages B & C for Worldwide Contact Information.**

# HARRIS ALLIED ENGINEERING DATA

## HARRIS ALLIED CONVERSION TABLES

### U.S. Measure To Metric System (Rounded)

#### LENGTH

Fractional  
Inches

Fractional Inches	Millimeters
1/16	1.6 (0.16 cm)
1/8	3.2 (0.32 cm)
3/16	4.8 (0.48 cm)
1/4	6.4 (0.64 cm)
5/16	7.9 (0.79 cm)
3/8	9.5 (0.95 cm)
7/16	11.1 (1.11 cm)
1/2	12.7 (1.27 cm)
9/16	14.3 (1.43 cm)
5/8	15.9 (1.59 cm)
11/16	17.5 (1.75 cm)
3/4	19.1 (1.91 cm)
13/16	20.6 (2.06 cm)
7/8	22.1 (2.21 cm)
15/16	23.8 (2.38 cm)

Inches Centimeters

1	2.54
2	5.08
3	7.62
4	10.16
5	12.70
6	15.24
7	17.78
8	20.32
9	22.86
10	25.40
11	27.94
12 (1 Ft.)	30.48
13	33.02
14	35.56
15	38.10
16	40.64
17	43.18
18	45.72
19	48.26
20	50.80

Inches	Centimeters	Inches	Centimeters
21	53.34	77	195.58
22	55.88	78	198.12
23	58.42	79	200.66
24	60.96	80	203.20
25	63.50	81	205.74
26	66.04	82	208.28
27	68.58	83	210.82
28	71.12	84	213.36
29	73.66	85	215.90
30	76.20	86	218.44
31	78.74	87	220.98
32	81.28	88	223.52
33	83.82	89	226.06
34	86.36	90	228.60
35	88.90	91	231.14
36	91.44	92	233.68
37	93.98	93	236.22
38	96.52	94	238.76
39	99.06	95	241.30
40	101.60	96	243.84
41	104.14	97	246.38
42	106.68	98	248.92
43	109.22	99	251.46
44	111.76	100	254.00
45	114.30	101	256.54
46	116.84	102	259.08
47	119.38	103	261.62
48	121.92	104	264.16
49	124.46	105	266.70
50	127.00	106	269.24
51	129.54	107	271.78
52	132.08	108	274.32
53	134.62	109	276.86
54	137.16	110	279.40
55	139.70	111	281.94
56	142.24	112	284.48
57	144.78	113	287.02
58	147.32	114	289.56
59	149.86	115	292.10
60 (5 Ft.)	152.40	116	294.64
61	154.94	117	297.18
62	157.48	118	299.72
63	160.02	119	302.26
64	162.56	120	304.80
65	165.10		
66	167.64		
67	170.18		
68	172.72		
69	175.26		
70	177.80		
71	180.34		
72	182.88		
73	185.42		
74	187.96		
75	190.50		
76	193.04		

1 inch = 2.54 cm  
 39.372 inches = 1 meter  
 3.281 Ft. = 1 meter  
 1 Ft.<sup>2</sup> = .0929 M<sup>2</sup>  
 1 Ft.<sup>3</sup> = .02832 M<sup>3</sup>

#### MASS (WEIGHT)

1 oz (Av).....28.3495g  
 1 lb (Av).....453.59g  
 2.2 lb (Av).....1 kg.

Engineering Data

# HARRIS ALLIED ENGINEERING DATA

## APPROXIMATE DISTANCES TO THE RADIO HORIZON VS VARIOUS TOWER HEIGHTS (FOR FM and TV)

TOWER HEIGHT IN METERS(M)  
DISTANCE TO RADIO HORIZON IN KILOMETERS(KM)

M	KM	M	KM	M	KM	M	KM
6	10.1	162	52.5	318	73.5	474	89.8
12	14.3	168	53.4	324	74.2	480	90.3
18	17.5	174	54.4	330	74.9	486	90.9
24	20.2	180	55.3	336	75.6	492	91.4
30	22.6	186	56.2	342	76.2	498	92.0
36	24.7	192	57.1	348	76.9	504	92.5
42	26.7	198	58.0	354	77.6	510	93.1
48	28.6	204	58.9	360	78.2	516	93.6
54	30.3	210	59.7	366	78.9	522	94.2
60	31.9	216	60.6	372	79.5	528	94.7
66	33.5	222	61.4	378	80.2	534	95.3
72	35.0	228	62.2	384	80.8	540	95.8
78	36.4	234	63.1	390	81.4	546	96.3
84	37.8	240	63.9	396	82.0	552	96.9
90	39.1	246	64.7	402	82.7	558	97.4
96	40.4	252	65.4	408	83.3	564	97.9
102	41.6	258	66.2	414	83.9	570	98.4
108	42.8	264	67.0	420	84.5	576	98.9
114	44.0	270	67.7	426	85.1	582	99.5
120	45.2	276	68.5	432	85.7	588	100.0
126	46.3	282	69.2	438	86.3	594	100.5
132	47.4	288	70.0	444	86.9	600	101.0
138	48.4	294	70.7	450	87.5	606	101.5
144	49.5	300	71.4	456	88.0	612	102.0
150	50.5	306	72.1	462	88.6	618	102.5
156	51.5	312	72.8	468	89.2	624	103.0

TOWER HEIGHT IN FEET (FT)  
DISTANCE TO RADIO HORIZON IN MILES (MI)

FT	MI	FT	MI	FT	MI	FT	MI
20	6.3	520	32.2	1020	45.2	1520	55.1
40	8.9	540	32.9	1040	45.6	1540	55.5
60	11.0	560	33.5	1060	46.0	1560	55.9
80	12.6	580	34.1	1080	46.5	1580	56.2
100	14.1	600	34.6	1100	46.9	1600	56.6
120	15.5	620	35.2	1120	47.3	1620	56.9
140	16.7	640	35.8	1140	47.7	1640	57.3
160	17.9	660	36.3	1160	48.2	1660	57.6
180	19.0	680	36.9	1180	48.6	1680	58.0
200	20.0	700	37.4	1200	49.0	1700	58.3
220	21.0	720	37.9	1220	49.4	1720	58.7
240	21.9	740	38.5	1240	49.8	1740	59.0
260	22.8	760	39.0	1260	50.2	1760	59.3
280	23.7	780	39.5	1280	50.6	1780	59.7
300	24.5	800	40.0	1300	51.0	1800	60.0
320	25.3	820	40.5	1320	51.4	1820	60.3
340	26.1	840	41.0	1340	51.8	1840	60.7
360	26.8	860	41.5	1360	52.2	1860	61.0
380	27.6	880	42.0	1380	52.5	1880	61.3
400	28.3	900	42.4	1400	52.9	1900	61.6
420	29.0	920	42.9	1420	53.3	1920	62.0
440	29.7	940	43.4	1440	53.7	1940	62.3
460	30.3	960	43.8	1460	54.0	1960	62.6
480	31.0	980	44.3	1480	54.4	1980	62.9
500	31.6	1000	44.7	1500	54.8	2000	63.2

# HARRIS ALLIED ENGINEERING DATA

## Bessel Nulls for Frequency Modulation Systems

A listing of useful carrier and first order sideband nulls as a function of the modulation index (m) and the modulating frequency (Fm) is given below:

Null	m = (Dev./ Fm) Modulation Index (m)		(FM) (Fm) for 75 kHz Deviation		(TV-MTS) (Fm) for 25 kHz Deviation		(SCA / PRO) (Fm) for 5 kHz Deviation	
	Carrier	1st Sidebands	Carrier	1st Sidebands	Carrier	1st Sidebands	Carrier	1st Sidebands
1st	m = 2.405	m = 3.832	31,185.0 Hz	19,572.0 Hz	10,395.0 Hz	6,524.0 Hz	2,079.0 Hz	1,304.8 Hz
2nd	m = 5.520	m = 7.016	13,587.0 Hz	10,689.9 Hz	4,529.0 Hz	3,563.3 Hz	905.8 Hz	712.7 Hz
3rd	m = 8.654	m = 10.173	8,666.5 Hz	7,372.5 Hz	2,888.8 Hz	2,457.5 Hz	577.8 Hz	491.5 Hz
4th	m = 11.792	m = 13.323	6,360.2 Hz	5,629.4 Hz	2,120.1 Hz	1,876.5 Hz	424.0 Hz	375.3 Hz
5th	m = 14.931	m = 16.470	5,023.1 Hz	4,553.7 Hz	1,674.4 Hz	1,517.9 Hz	334.9 Hz	303.6 Hz
6th	m = 18.071	m = 19.616	4,150.3 Hz	3,823.4 Hz	1,383.4 Hz	1,274.5 Hz	276.7 Hz	254.9 Hz
7th	m = 21.212	m = 22.760	3,535.7 Hz	3,295.3 Hz	1,178.6 Hz	1,098.4 Hz	235.7 Hz	219.7 Hz

Engineering Data

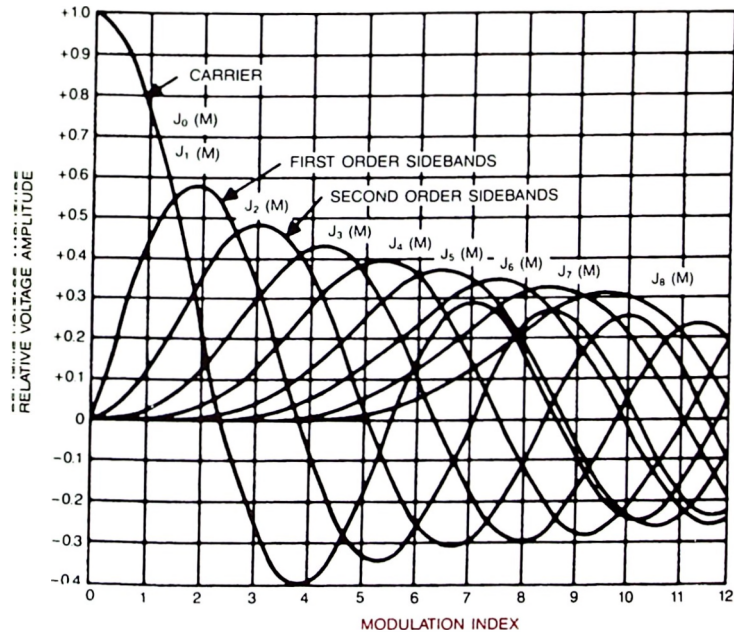

Relationship of carrier and sideband amplitudes to modulation index

FREQUENCY IN HERTZ	DECIBELS
400 HZ	0.15 db
1,000	0.87
2,000	2.76
3,000	4.77
4,000	6.58
5,000	8.16
6,000	9.54
7,000	10.75
8,000	11.82
9,000	12.79
10,000	13.66
11,000	14.45
12,000	15.18
13,000	15.86
14,000	16.49
15,000	17.07

75 Microsecond pre-emphasis response

# HARRIS ALLIED ENGINEERING DATA

## Frequency Designation of FM Broadcast Channels

Freq. (MHz)	Channel No.	Freq. (MHz)	Channel No.	Freq. (MHz)	Channel No.	Freq. (MHz)	Channel No.	Freq. (MHz)	Channel No.
88.1	201	98.1	251	90.9	215	100.9	265	94.5	233
88.3	202	98.3	252	91.1	216	101.1	266	94.7	234
88.5	203	98.5	253	91.3	217	101.3	267	94.9	235
88.7	204	98.7	254	91.5	218	101.5	268	95.1	236
88.9	205	98.9	255	91.7	219	101.7	269	95.3	237
89.1	206	99.1	256	91.9	220	101.9	270	95.5	238
89.3	207	99.3	257	92.1	221	102.1	271	95.7	239
89.5	208	99.5	258	92.3	222	102.3	272	95.9	240
89.7	209	99.7	259	92.5	223	102.5	273	96.1	241
89.9	210	99.9	260	92.7	224	102.7	274	96.3	242
90.1	211	100.1	261	92.9	225	102.9	275	96.5	243
90.3	212	100.3	262	93.1	226	103.1	276	96.7	244
90.5	213	100.5	263	93.3	227	103.3	277	96.9	245
90.7	214	100.7	264	93.5	228	103.5	278	97.1	246
				93.7	229	103.7	279	97.3	247
				93.9	230	103.9	280	97.5	248
				94.1	231	104.1	281	97.7	249
				94.3	232	104.3	282	97.9	250
								104.5	283
								104.7	284
								104.9	285
								105.1	286
								105.3	287
								105.5	288
								105.7	289
								105.9	290
								106.1	291
								106.3	292
								106.5	293
								106.7	294
								106.9	295
								107.1	296
								107.3	297
								107.5	298
								107.7	299
								107.9	300

### Decibels Vs Ratio

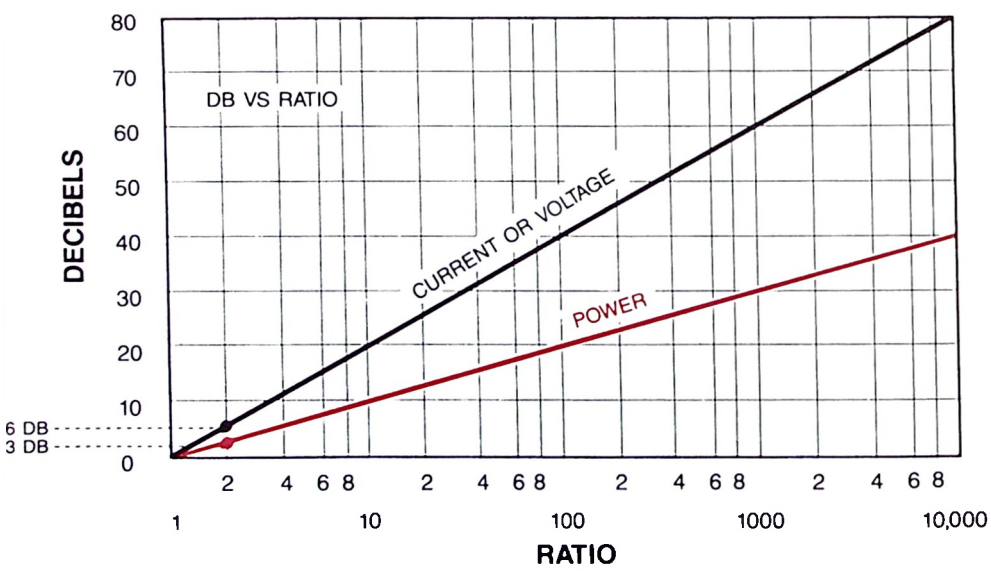

### Volume Level to Power and Voltage Conversion

REFERENCE LEVEL: 0 DBM = 1 MW, 600 OHMS

MILLIWATTS	VOLTS	DBM	WATTS	VOLTS	DBM
0.000001	0.0007746	-60	0.001000	0.7746	0
0.000010	0.002449	-50	0.002512	1.228	+4
0.000100	0.007746	-40	0.006310	1.946	+8
0.001	0.02449	-30	0.01000	2.449	+10
0.010	0.07746	-20	0.1000	7.746	+20
0.100	0.2449	-10	1.000	24.49	+30
1.000	0.7746	0	10.00	77.46	+40





# HARRIS ALLIED ENGINEERING DATA

## Voltage Standing Wave Ratio Relationships

VSWR	REFLECTION COEFFICIENT	RETURN LOSS	POWER RATIO	PERCENT REFLECTED
1.01 : 1	.0050	46.1 dB	.00002	.002%
1.02 : 1	.0099	40.1 dB	.00010	.010%
1.04 : 1	.0196	34.2 dB	.00038	.038%
1.06 : 1	.0291	30.7 dB	.00085	.085%
1.08 : 1	.0385	28.3 dB	.00148	.148%
1.10 : 1	.0476	26.4 dB	.00227	.227%
1.20 : 1	.0909	20.8 dB	.00826	.826%
1.30 : 1	.1304	17.7 dB	.01701	1.7%
1.40 : 1	.1667	15.6 dB	.02778	2.8%
1.50 : 1	.2000	14.0 dB	.04000	4.0%
1.60 : 1	.2308	12.7 dB	.05325	5.3%
1.70 : 1	.2593	11.7 dB	.06722	6.7%
1.80 : 1	.2857	10.9 dB	.08163	8.2%
1.90 : 1	.3103	10.2 dB	.09631	9.6%
2.00 : 1	.3333	9.5 dB	.11111	11.1%
2.20 : 1	.3750	8.5 dB	.14063	14.1%
2.40 : 1	.4118	7.7 dB	.16955	17.0%
2.60 : 1	.4444	7.0 dB	.19753	19.8%
2.80 : 1	.4737	6.5 dB	.22438	22.4%
3.00 : 1	.5000	6.0 dB	.25000	25.0%
3.50 : 1	.5556	5.1 dB	.30864	30.9%
4.00 : 1	.6000	4.4 dB	.36000	36.0%
4.50 : 1	.6364	3.9 dB	.40496	40.5%
5.00 : 1	.6667	3.5 dB	.44444	44.4%
6.00 : 1	.7143	2.9 dB	.51020	51.0%
7.00 : 1	.7500	2.5 dB	.56250	56.3%
8.00 : 1	.7778	2.2 dB	.60494	60.5%
9.00 : 1	.8000	1.9 dB	.64000	64.0%
10.00 : 1	.8182	1.7 dB	.66942	66.9%
15.00 : 1	.8750	1.2 dB	.76563	76.6%
20.00 : 1	.9048	.9 dB	.81859	81.9%
30.00 : 1	.9355	.6 dB	.87513	87.5%
40.00 : 1	.9512	.4 dB	.90482	90.5%
50.00 : 1	.9608	.3 dB	.92311	92.3%

$$VSWR = \frac{1 + |p|}{1 - |p|} = \frac{1 + \sqrt{(Prfl/Ptwd)}}{1 - \sqrt{(Prfl/Ptwd)}}$$

POWER RATIO = (Prfl/Ptwd)

$$p = \frac{VSWR - 1}{VSWR + 1} = \text{REFLECTION COEFFICIENT}$$

RETURN LOSS =  $-20 \log |p|$

# DIGITAL TERMINOLOGY for a NEW GENERATION

## (includes basic DAB and DAB RF Modulation)

**16QAM:** This digital modulation method uses 16 possible states of amplitude and phase (4 x 4) to send 4 bits at a time.

**32QAM:** This digital modulation method uses 32 possible data states and can send 5 bits per second per Hertz depending upon designer configuration. Higher number QAM systems have also been developed including at least 256QAM (possible 8 bits).

**AES/EBU:** Audio Engineers Society/European Broadcasters Union - Two organizations that agreed upon a standard for the exchange of digital audio within the studio environment.

**Algorithm:** A rule or procedure for solving a mathematical problem. In this case, the problem is to reduce the amount of digital data to be transmitted to conserve bandwidth. This article mostly refers to source compression algorithms.

**Analog Audio:** a continuous, varying voltage which represents the electrical equivalent of sound. Analog Audio has infinite precision within limits of S/N, since it is continuous. Analog audio of sufficient level may be used directly to drive an audio speaker, which changes the electrical energy back into acoustic energy (sound).

**Analog to Digital Converter:** A device, usually an integrated circuit, which samples the incoming analog audio and outputs digital audio of defined word lengths such as 12 bit A/D or 16 bit A/D.

**Binary Numbers:** Numbers based on the power of 2 and expressed as either a 1 or 0. For example, number 1 appears in a 5 bit word as 00001; number 2 appears in a 5 bit word as 00010; number 4 appears in a 5 bit word as 00100, etc.

**Bit:** The smallest element of a digital signal. It is usually expressed in a two state form, on/off, +/-, hi/lo, etc. Most of the time binary numbers are used to represent the two states, specifically 1 and 0.

**BER:** Bit Error Rate - This term is an important indicator of the performance of the digital system. BER is the number of bits received in error divided by the number of bits sent. In various systems, there is a qualitative as well as quantitative aspect to bit errors. Some bit errors can cause more problems than others. Standards for a particular digital system will eventually be set.

**bps/Hz:** bits per second per Hertz is a spectral efficiency number. Bps divided by occupied bandwidth gives bit/sec/Hz.

**BPSK:** Bi-Phase Shift Keying - Digital bits are sent one at a time by shifting the carrier phase back and forth 180 degrees. This method also requires wide bandwidth, however it does have the advantage of being least susceptible to noise. (Also, BSK Binary Shift Keying.)

**Carrier Recovery:** For most digital decoding, an in-phase reference is required. The carrier is the reference for most systems. The carrier is used as the starting point phase reference ( $I$ ) for the QAM decoding process. Therefore, some method of carrier recovery for the digital decoding process is required.

**CCIR:** International Radio Consultative Committee - An international radio standards setting organization.

**Constellation Pattern:** A constellation pattern is a vector diagram indicating the proper landing points for each QAM element. This vector diagram can be set up to read amplitude and phase errors as the sent digital elements fall outside of the proper landing points. This type of test is also very helpful in determining why the BER may be high and also what may be required in the way of precorrection to place the elements back on their respective landing points.

**DAB:** Digital Audio Broadcasting is a generic term which is used for the delivery of digital audio by any method such as satellite, microwave, BC carrier, etc.

**DAR:** Digital Audio Radio - DAB as it refers to digital radio broadcasting.

**Data Port:** The physical and electrical protocol used by a codec and the DSU (Data Service Unit) or TA (Terminal Adapter) to transfer data between each other. A codec comes with either a V.35 or X.21 protocol built in. These numbers refer to CCITT international standards with V.35 very common for networks in North America and X.21 popular on European-manufactured ISDN terminal adapters.

**dBc:** Decibels referenced to carrier.

**DBS:** Direct Broadcast Satellite - Satellite radio broadcasts direct to home or car.

**Digital Audio:** A representation of analog audio created by taking samples of the analog audio at specific points in time. Digital audio uses bits to record the analog voltage. Because digital audio is finite, the more bits used at each sample point, the better the quality of the recreated audio when converting digital audio back to analog audio.

**Digital to Analog Converter:** A device, usually an integrated circuit, which converts digital words into a standard varying audio voltage which is representative of the original analog audio.

**DSP:** Digital Signal Processing is the process of changing analog audio signals to a digital format that may also be compressed and stored or transmitted in the digital domain.

**DDSP:** Dual Digital Signal Processing allows record and playback at the same time.

## DIGITAL TERMINOLOGY (continued)

**DSU/CSU:** Data Service Unit/Channel Service Unit. Required between a codec and SW56 or DDS circuits, these are used to interface and condition the data coming on and off the network. It may contain diagnostic testing functions and will perform dialing tasks for switched services.

**DTE/DCE:** Data Terminal Equipment and Data Computer Equipment. To avoid confusion, the data protocols mentioned above designate equipment and ports as either DTE or DCE. In the case of the codec, the DSU/CSU or TA is always the DCE and the codec is always the DTE.

**EIA:** Electronic Industries Association - An electronics industry-sponsored organization interested in lobbying and setting standards. EIA is involved in all areas of electronics.

**Eye Pattern:** A test pattern used to check the digital signal for proper operation. By sending a signal that cycles through all the QAM points, the signal can be observed on an oscilloscope. The pattern that emerges resembles the outline of a human eye — thus, its name. By observing the eye pattern on the oscilloscope, transmission anomalies, including distortion of the waveform by deviations in gain and phase from the ideal, may be observed. Observing distortions of the eye pattern can help to determine the reasons why the bit error rate (BER) may have increased.

**FEC:** Forward Error Correction - Specifically, FEC is an error correction system which encodes certain bits into the digital signal to provide a decoding scheme at the receive end which corrects for random errors. It is a system that substitutes for an error bit what it believes the correct bit should be. It may also be used in a generic sense for any system that encodes data to help minimize bit errors on the receiving end.  $r = \text{rate}$ . For example,  $\frac{3}{4}$  FEC means for every 3 data bits sent, 1 FEC bit is sent.

**Fragmentation:** After writing information to a hard disk for a period of time, the disk develops areas too small to fit complete files. The system must spread the file over several areas of the disk to store. Because the read/write head must jump between these locations, the access time is slowed down, sometimes drastically.

**Group Delay:** This term defines the amount of time delay that may occur in a modulated signal as a function of frequency. Any unwanted delays in time affect phase relationships which may upset the proper decoding of the QAM signal. In some cases, group delay problems may be improved by transmitter precorrection circuitry.

**I:** Used to represent the in-phase component of a signal or vector. It is usually used as the reference.

**IBAC:** In Band Adjacent Channel - A form of DAB in which the digital audio signal is broadcast on an adjacent channel to the main carrier of the analog program audio. This method is similar to IBOC in that the station would still be identified by its analog carrier signal and the DAB receiver would be the most likely place to do the offset to extract the digital

information. (IBAC has been suggested in some FM DAB proposals.)

**IBOC:** In Band On Channel - A form of DAB in which the digital audio is broadcast within the same channel allocation as the standard analog program audio.

**Interleaving:** This is a digital audio encoding process which clocks the data into a matrix of columns and then clocks it out by columns. This process minimizes loss of decoded audio due to short-term static impulse noise. The interleaver separates the bits from each other to spread out the burst of errors caused by a static pop so the FEC can work and correct the errors. The FEC and interleaver work together to allow the decoded audio to not be affected by loss of bits due to static impulse noise.

**IPM:** Incidental Phase Modulation - This term defines the amount of unwanted phase modulation that may occur in an AM transmitter. Any phase modulation not produced by the QAM modulation process would hinder the decoding the digital signal and proper recovery of the bits. In some cases, IPM may be improved by transmitter precorrection circuitry.

**IQM:** Incidental Quadrature Modulation is the amount of incidental phase modulation located at the 90 degree quadrature point of the carrier signal. This measurement has become a radio specification number due to the fact that the L-R signal of AM stereo is located here in quadrature.

**ISDN:** Integrated Services Digital Network. The worldwide standard for digital telephony, it actually describes a complex set of international standards.

**ISO/MPEG:** A source compression algorithm proposed by two organizations: International Standards Organization/Moving Picture Experts' Group. This algorithm is also associated with digital television.

**kbps:** kilobits per second is the number of thousands of bits sent per second.

**Musicam:** One of the patented source compression algorithms used to reduce the amount of digital information that needs to be sent for high quality stereo audio. It uses psychoacoustic knowledge and statistical information to determine which information may be deleted for data reduction purposes.

**MTBF:** Mean Time Before Failures is the estimated life for devices such as hard disks, etc.

**NRSC:** National Radio Systems Committee - a radio industry-sponsored group interested in setting standards for the improvement and compatibility of radio systems. NRSC is particularly interested in IBOC DAB systems.

**OOK:** On/Off Keying - Sending digital information one bit at a time by turning the carrier on and off. Requires wide bandwidth and recovery of data. Is difficult without a continuous carrier.

## DIGITAL TERMINOLOGY (continued)

**Optimization:** A process where the computer reorganizes the information on the hard drive in order to eliminate the fragmented areas. This in turn improves the access time for the disk. Depending on the size of the disk, this process can take many hours and precludes any other operation on the computer.

**FPAC:** Perceptual Audio Coding - A source compression algorithm which also uses psychoacoustic knowledge and statistical information.

**Psychoacoustic:** Refers to the way the human ear perceives sound. Not all sound is processed equally by the human ear/brain complex. In audio, certain aspects of sound are more important than others to human perception. Source compression algorithms exploit this characteristic of human hearing in an effort to reduce the amount of digital information that needs to be stored or broadcast. By reducing the amount of digital data to be broadcast, a reduction in transmitted bandwidth can be achieved while maintaining the sonic qualities that are important to the human ear.

**Q:** Used to represent a phase shifted signal or vector when compared to the reference I. It is used when referring to a 90-degree phase shift, also known as quadrature.

**QAM:** Quadrature Amplitude Modulation - A digital modulation method that uses various states of phase and amplitude to send digital data. There are many forms of QAM: 16QAM, 32QAM, 64QAM, 128QAM, etc. The big advantage of QAM systems is that more bits may be sent at the same time, helping to reduce bandwidth requirements. The trade-off is that the higher the number of QAM points, the greater the difficulty in recovering all the bits because the probability of errors increases due to noise, phase and amplitude errors interfering with proper bit recovery.

**QPSK:** Quadrature Phase Shift Keying - This digital modulation method sends four digital data states. Four phase positions are utilized 45, 135, 225 and 315 degrees at a fixed amplitude.

**RAM:** Random Access Memory. Memory that can store data that can be changed.

**ROM:** Read Only Memory. It can store data but cannot be changed.

**Sample Rate:** The number of times per second (frequency) in which the analog audio is read and a digital word is created to represent that particular voltage at that point in time.

**SER:** Symbol Error Rate - Similar to BER except that in this case, it is the number of symbols received divided by the number of symbols sent. This is a measurement method to determine the amount of the digital symbols that are received along a signal path without errors.

**SNR:** Signal to Noise Ratio - Same as RF S/N.

**Source Compression Algorithm:** A means of reducing the total volume of digital information to be stored or sent by making more efficient use of digitally packing the information along with deleting information of little or no value. In recent times, most source compression algorithms involve source information reduction as well. In formulating source compression algorithms, designers determine that some of the information may be considered unnecessary. One of the criterion most often used for information deletion (beside statistical data) is based on psychoacoustic research into human hearing and how the brain processes information.

**Symbol:** A grouping of a defined number of bits that is sent together as encoded data. For example, it could be 1, 2, 3, or more bits per symbol.

**TA:** Terminal Adapter. This, in effect, is a CSU/DSU for an ISDN line. It adapts non-ISDN equipment to the ISDN user rate.

**USA Digital:** Consortium of Group W, Gannett Radio, and CBS; USA Digital Radio has also been called Project Acorn.

**USADR:** USA Digital Radio.

**Word:** The number of bits expressed in binary form is used to define or represent a particular sample port (12 bit word, 14 bit word, 16 bit word). The more bits, the better the ability of the digital information to recreate the analog audio. Number of bits define the level of audio quality to be recovered from the digital audio.

**WORM:** Write Once Read Many. A data storage device such as CDs, and some magneto optical disks.

**Wireline Test:** This is a method where the signal to be tested is sent over a closed system such as a coaxial cable rather than over the air. It is a less stringent test than would be encountered in actual over the air tests.

**Xetron Corporation:** Subsidiary of Westinghouse Electric Corporation; developers of USA Digital Radio AM DAB.

**ZIP** — nothing more — that's it for me folks! After 10 years with Allied and Harris Allied, I've decided to retire at years end; so this catalog essentially is my "swan song." After a multitude of brochures, catalogs, ads, spec. sheets, fliers, shows, mailers, newspapers, etc., etc., etc. I'm going "out to pasture." To all my broadcast friends worldwide — thanks for your help, patience and friendship. Very special thanks to Sandy — also to Martha, Deb, Melany, Beth, Roy, Charlie, Dave & Joe. Peace!



- A -

3M.....73, 124  
 66 PUNCH BLOCKS.....91  
 ABCO.....34, 45  
 AC POWER  
 Distribution.....86  
 Phase Converters.....219  
 Standby Generators.....219  
 Surge Protection.....85-86  
 ACOUSTICAL TREATMENT.....84  
 ADAT.....66  
 ADC.....91  
 Addresses, Harris Allied.....B-C  
 ADRAN.....159  
 AEQ  
 Consoles & Mixers.....47  
 Speakers.....140  
 Telephone Hybrid.....162  
 AIR CORP  
 Audio Processing.....10  
 MO Recorders.....66  
 AKG  
 Headphones & Headsets.....97  
 Microphones.....106  
 ALC.....140  
 ALESIS.....66  
 A-LINE  
 Cart Racks.....34  
 CD Storage.....45  
 Equipment Rack.....79  
 Record Storage.....79  
 Side Panels.....124  
 ALLEN & HEATH  
 Consoles & Mixers.....47  
 AM NOISE MONITOR.....121  
 AM SIGNAL PROCESSING.....12-13, 17, 21  
 AM STEREO  
 Exciters.....215, 218  
 Monitors.....215  
 AM TRANSMITTERS.....176-179  
 AMPEX TAPE  
 R-DAT.....73  
 Reel-To-Reel.....124  
 AMPLIFIERS  
 Headphone.....1-2, 4, 6, 8-9  
 Mic Preamp.....1, 4, 6-9  
 Phono.....2, 7-9  
 Power.....3-7, 9  
 ANALYZER, DISTORTION/NOISE.....170  
 ANDREW.....129, 212-213  
 ANJ.....128  
 ANTENNA ACCESSORIES.....203  
 ANTENNA COUPLING UNIT, MW.....202  
 ANTENNA MONITORS.....120  
 ANTENNAS  
 AM.....201-202  
 FM.....200, 204-206  
 UHF.....206-207, 210-211  
 VHF.....200, 205-209  
 ANVIL.....89  
 APHEX  
 Audio Processing.....10-12  
 Distribution Amps.....74  
 Equalizers.....12  
 FM Stereo Generator.....10-11  
 Interfaces.....102  
 ARAKIS  
 Automation.....24-25, 235  
 CD Storage.....45  
 Consoles & Mixers.....47-48, 235  
 Digital Editing.....63  
 Furniture.....80-81  
 Gemini.....235  
 Modulink System™.....80  
 Modulux™.....80-81  
 ART.....12  
 ASTROLITE.....97  
 ATI  
 Audio Distribution.....74-75  
 Audio Level Monitors.....115  
 Consoles & Mixers.....2, 48-49  
 Dual Line Amp.....102  
 Headphone Amps.....1  
 Impedance Interface.....102  
 Mic Preamp.....1  
 Noise Generators.....169  
 Phono Preamp.....2  
 ATLAS SOUND.....87  
 ATLAS/SOUNDOLIER.....79  
 AUDI-CORD.....31  
 AUDIO  
 Connectors.....91  
 Distribution Amps.....74-75  
 Level Monitoring.....115, 118  
 AUDIO DELAY.....62  
 AUDIO PROCESSING  
 AM Signal.....12, 13, 17, 21  
 Aural Exciter.....10, 12  
 Composite.....15, 18  
 Compressor/Limiter.....10, 12-15, 22-23

Effects.....12, 16, 18, 23  
 Equalizer.....12, 16, 20, 23  
 FM Signal Processing.....12-15, 17, 20  
 FM Stereo Generator.....10, 17  
 Mic Processor.....10, 13, 20, 22  
 Multi Function.....12, 17  
 Noise Gate.....12, 17  
 Noise Reduction.....13, 15-16, 18, 20-21, 23  
 Orban.....19  
 Peak Limiters.....10, 13  
 Short-wave.....13  
 Stereo Generator.....12  
 Stereo Synthesizer.....18  
 AUDIOLAB.....35, 88  
 AUDIOMETRICS  
 CD-10 CD Player.....41  
 CD Storage.....44  
 Distribution Amp.....75  
 Mic Stands.....87  
 Phono Preamp.....2  
 Retrofit Card.....35  
 Timers.....86  
 AUDIOPAK.....35  
 AUDIO TECHNICA  
 Consoles & Mixers.....52  
 Microphones.....107  
 AUDISAR.....75  
 AUDITRONICS  
 Automation.....235  
 Consoles & Mixers.....50-51, 235  
 AUTOGRAM.....52  
 AUTOMATION.....24-30, 235

- B -

B & B SYSTEMS.....115  
 BEC TECHNOLOGIES.....143  
 BELAR  
 Audio Sentry.....30  
 Frequency Monitors.....116  
 Modulation Monitors.....116-117  
 Receiver-FM.....116  
 Remote Meter Panel.....117  
 RF Amplifiers.....117  
 BELDEN.....92  
 BENCHMARK.....2, 102  
 BEST.....85  
 BEVCO.....79  
 BEXT.....182  
 BEYER  
 Headphones & Headsets.....98-99  
 Microphones.....106  
 BGW.....3  
 BIRD.....214  
 BROADCAST AUDIO.....55  
 BROADCAST DEVICES.....76  
 BROADCAST TOOLS.....101, 235  
 BULBS.....215  
 BULK ERASERS.....35-38, 88  
 BULK TAPE.....36, 124  
 Bulletin Board System.....236  
 BURK TECHNOLOGY  
 Remote Control.....125  
 Routing Switcher.....76  
 SCA Generator.....214  
 BROADCAST ELECTRONICS  
 Bulk Eraser.....35  
 Cartridge Machines.....31  
 Consoles & Mixers.....53

- C -

CABINET.....83  
 CABLEWAVE.....129, 200, 216  
 CADDY, CD.....42  
 CALIFORNIA AMPLIFIER.....129  
 CANARE.....91  
 CART LABELS.....38  
 CART RACKS.....34, 36, 38  
 CARTRIDGES & ACCESSORIES.....34  
 CARTRIDGE MACHINES.....31-32  
 CARTRIDGE WINDER.....38  
 CARTRIDGES, BLANK.....35-36, 38  
 CARTRIDGES, BULK TAPE.....35-36  
 CARTRIDGE, CD.....42  
 CARVER  
 Power Amplifiers.....3  
 Tuners.....115  
 CASES, SHIPPING.....89  
 CASSETTE RECORDERS.....39-40  
 CCS.....159  
 CD 10.....41  
 CD CARTRIDGE.....42  
 CD MUSIC.....46  
 CD PLAYERS.....41-43  
 CD RECORDERS.....43  
 CD STORAGE.....44-45  
 CHAIR, STUDIO.....79  
 CIRCUIT RESEARCH LABS.....(See CRL)  
 CLEANING STICKS.....88  
 CLOCKS & TIMERS.....86

COAX SWITCHES.....215-216, 220  
 CODECS.....159-160  
 COLORADO MAGNETICS.....129  
 COMARK.....214  
 COMPOSITE  
 Distribution.....78  
 Processor/Filter.....15, 18  
 COMPRESSOR.....16  
 COMPRESSOR/LIMITER.....22-23  
 COMPUTEMP.....222  
 COMREX  
 CODECS.....160  
 Couplers.....161  
 Frequency Extenders.....160-161  
 Intercom Systems.....101  
 Talk Console.....161  
 Telephone Interface.....161  
 COMTECH.....130  
 CONDENSER MICROPHONES.....106-107, 110-113  
 CONEX.....30, 76, 131  
 CONNECTORS, MIC.....91  
 CONSOLES & MIXERS  
 Mic/Line.....2, 58  
 Portable.....47-48, 56, 58-61  
 Rack Mount.....53, 58-59, 61  
 Retrofit Modules.....53  
 Studio/On-Air.....47-61, 235  
 CONTROL CONCEPTS.....85  
 CONTROL INTERFACES.....103-104, 235  
 COPPER PRODUCTS.....94  
 COTTON SWABS.....88  
 COUNTERS, FREQUENCY.....169-170  
 COUPLERS  
 Directional.....214  
 Telephone.....161-164, 168  
 CRL  
 Audio Processing.....12-13  
 Clocks & Timers.....86  
 Digital Analyzers.....169  
 RDS/RBDS.....122  
 SCA Generators.....215  
 CROWN  
 Headphones & Headsets.....98  
 Power Amplifiers.....3  
 CUTTING EDGE TECHNOLOGIES  
 Composite Filter.....14  
 FM Processor.....14-15

- D -

DAD486X.....28-29  
 DAT  
 Recorders.....68-72  
 Tape.....73  
 DAVTRONICS  
 Distribution-Signal.....76  
 RF Amplifier-AM.....115  
 DBX.....15-16  
 DC BLOCK.....131  
 DEGAUSSERS.....35-38  
 DEHYDRATORS.....212, 218  
 DELAY LINES  
 Audio.....62  
 Video.....62  
 DELTA  
 AM Measurement Equipment.....215  
 AM Stereo Exciters.....215  
 Coax Switches.....215  
 Splatter Monitor.....118  
 DENON  
 Cassette Recorders.....39  
 CD Cartridge.....42  
 CD Players.....42  
 CD Test Disc.....42  
 MiniDisc.....66  
 R-DAT Tape.....73  
 DHK.....26-27  
 Desk\*Star™.....81  
 Destiny 2000.....235  
 DIELECTRIC.....216  
 Digilink.....24-25  
 DIGIMAX.....169  
 DIGITAL  
 Audio Processing.....15-23  
 Automation.....24-30, 235  
 CD Players.....41-43  
 CD Recorders.....43  
 DAT Recorders.....68-72  
 Delay Lines.....62  
 Editing.....63-65  
 Logging Systems.....66-67  
 Recorders.....66-73  
 Telephone Equipment.....160-168  
 Thermometer.....222  
 DIGITAL ANALYZERS.....169  
 DIGITAL AUDIO LABS.....63  
 DIGITAL EDITING.....63  
 DIGITAL PLAYER.....66  
 DIGITAL RECORDERS  
 ADAT.....66, 68  
 Floppy.....68

Logging.....66-67  
 Magneto Optical.....66  
 Micro Digital.....71  
 MiniDisc.....66, 69, 71  
 Multi-Track.....73  
 R-DAT.....68-72  
 R-DAT Tape.....72  
 Remote Control.....70  
 Solid-State.....68-69  
 DIPEXERS, MW.....202  
 DISHES, SATELLITE.....130  
 DISTRIBUTION - SIGNAL  
 Audio.....74-78, 235  
 Composite.....78  
 Routing Switcher.....74, 76-78, 235  
 Video.....71  
 DORROUGH.....111  
 DSE7000.....64-65  
 DTMF EQUIPMENT.....136  
 DUMMY LOADS.....214, 218  
 DURO-TEST.....215  
 DYNAMIC MICROPHONES.....106-109, 111, 113

- E -

Easfax Line Cutter.....213  
 EBS.....120-121, 218  
 EDCOR.....12, 16, 18, 21  
 EFFECTS, AUDIO.....12, 16, 18, 21  
 EFL.....81  
 ELECTRO IMPULSE.....214  
 ELECTRONIC RESEARCH.....131  
 ELECTRO VOICE  
 Microphones.....108-110  
 Mixers.....53  
 Speakers.....140  
 ELGIN.....161  
 ENBERG.....91  
 ENCO DAD486X.....28-29  
 Encore DSR-3610.....131  
 ENGINEERING DATA AND TABLES.....223-224  
 ENG/EPV VEHICLES.....150-151  
 ENVIRONMENTAL TECHNOLOGIES.....131, 218  
 EQUALIZERS  
 Audio.....12, 16, 20, 23  
 Telephone.....162  
 EQUIPMENT EXCHANGE.....C, D, 124  
 EQUIPMENT RACK.....79, 82-84  
 ESE.....81  
 ETA.....81  
 ETT.....121, 211  
 EVENTIDE  
 Delay Lines-Audio & Video.....61  
 Digital Effects.....1  
 Logging.....66-67  
 EXCALIBUR.....77, 161  
 EXCITERS  
 AM Stereo.....215, 218  
 FM.....181-183  
 TV.....191

- F -

FAX Numbers, Harris Allied.....B-C  
 FFI.....121  
 FIDELIPAC  
 Bulk Eraser.....36-37  
 Bulk Tape.....36-37  
 Cart Racks.....36-37  
 Cartridge Machines.....37  
 Consoles & Mixers.....54-55  
 Digital Recorders.....61  
 Interfaces.....10  
 Tape Cartridges.....36-37  
 Warning Lights.....37, 91  
 FIELD STRENGTH METERS.....121  
 FIXED SYSTEMS.....150-151  
 FLEXIBLOCK.....9  
 FLOPPY DISC RECORDERS.....6  
 FM  
 Antennas.....200, 204-206  
 Processing.....12-15, 17, 19, 20  
 Stereo Generator.....10-15, 17  
 Transmitters.....183-188  
 FOSTEX  
 Digital Recorders.....61  
 Headphones & Headsets.....91  
 Speakers.....140  
 Test Equipment.....169  
 FREQUENCY  
 Extenders.....160-161  
 Monitors.....111  
 FURNITURE.....79-81  
 FX RACK.....8

- G -

GARNER.....38, 81  
 GATES TRANSMITTERS.....17  
 GEMINI.....23  
 GENERATORS  
 AC Power.....215, 218  
 AM Stereo.....215, 218  
 FM Stereo.....10-15, 17







## ARRAKIS

### Gemini Radio Digital Workstation

Gemini is the new live radio digital workstation from Arrakis. Gemini provides a full-range of capabilities to and for the live, on-air personality in every size and velocity of radio broadcast operation. Remarkably simple to use, the Gemini series of digital audio workstations bridges the gap between the way digital technology works (and is driving your operation) and the needs of demanding on-air talent. Gemini can simultaneously play a music bed, add a phoner, drop in a sound effect, record a caller and record a new spot. Handling the morning drive "zoo," donuts, contests and other program elements has never been this easy.



## AUDITRONICS



### Destiny 2000 Program Management System

The Auditronics Destiny 2000 Program Management System and Console integrate *current* computers and equipment into one master program management system. Music and traffic schedule computers, as well as production room hard disk computers, can be networked into one system controlled by the Destiny 2000. Clutter is gone because commercial copy, music and traffic logs are in the computer. The CDs are in the jukebox and the tape carts are replaced by the hard disk storage. The Console is available in 8, 12 or 16 input mainframes, which includes the program management computer software.

## BROADCAST TOOLS INC.



### 6x1 Stereo Router

The BTI 6x1 Stereo Router is passive balanced and may be used as a 6x1 or 1x6 audio routing switcher. The Broadcast Tools' routing switcher accomplishes audio routing with gold bifurcated relays, driven by a diode matrix and CMOS latches. With the audio path being passive, the 6x1 is perfect for input or output audio routing applications. Remote control is available from a standard 25-pin "D" connector.

### Console Controller II

The BTI Console Controller II provides the solution for interfacing non-broadcast consoles or digital workstations to the broadcast studio. Equipped with 3 channels of insert switching, console insert points or source equipment (mic-pre's) may be turned off or on, as indicated by a bright red LED on each switch. Additionally, the CC-II provides a front panel switch to allow internal/external monitor input switching or monitor amplifier mute control and front panel monitor level control. Easy installation. Remote controllable.

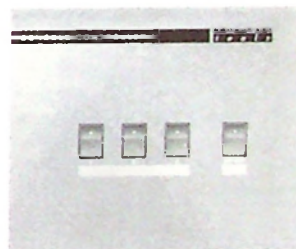

## HENRY

### StereoSwitch Stereo Audio Switcher

Henry's new StereoSwitch is a versatile 3-input stereo audio switcher for radio and TV stations. Ideally suited as a studio switcher, line selector or for automatic source selection under the control of a broadcast automation system. It accepts up to 3 stereo balanced audio sources, selecting one to be routed to the stereo balanced output. StereoSwitch utilizes sealed relays with gold-plated contacts for audio switching. 7.0"Wx5.5"Hx2.5"D, Unit weight: 3 lbs.



Late Additions

## LBA TECHNOLOGY

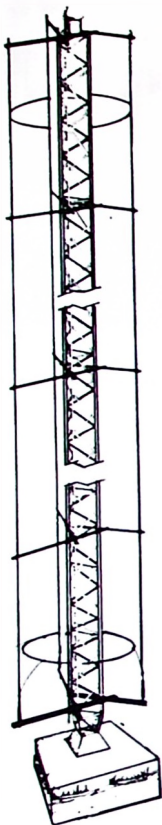

### EFFICIENCY

- Radiation model identical to "Series Fed" antennas.
- Effective matching and impedance transformation
- Reduces loss in tuning units and in marginal and deteriorated ground systems.
- Increases radiated field toward theoretical values.

### ISOLATION

- Use AM tower for FM, two-way or microwave antennas.
- Tower base at RF ground potential eliminates the need for lightning chokes, FM quarter wave stubs or two-way isocouplers.

### LIGHTNING PROTECTION

- Tower directly grounded to offer highest level of protection to transmission equipment.

### CUSTOMIZED OPTIONS

- Folded unipole systems are designed specifically for AM broadcast operation and can be used in both directional and non-directional systems. These systems have been proven in use for over 15 years.
- Special configurations for powers up to 250,000 watts and special environments.
- Also available are **Tuning Units**, **Power-topper™** top loading, **Basemax™** base efficiency systems, and **Detuning Systems**.

See *Transmitting Antenna Section on Pages 200 - 211.*

### Tunipole™ Antenna System

LBA Tunipole™ Folded Unipole Systems deliver higher efficiency and bandwidth than series fed towers while providing lightning protection. Designed specifically for Medium Wave AM broadcasting, Tunipoles are ideal for both directional and non-directional antenna systems.

## QEI

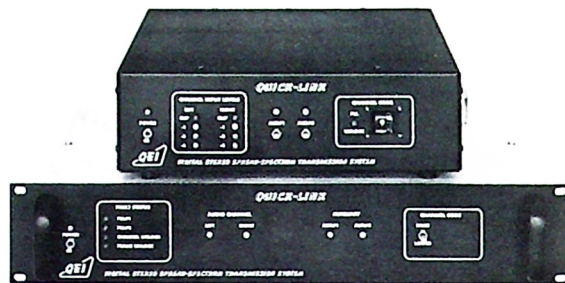

### Quick-Link Digital Remote Pickup System

The new Quick-Link Digital Remote Pickup System from QEI is the first real time, non-compressed, stereo digital system for RPU and TSL applications allowing you to establish a digital stereo audio path from a remote broadcast site to your studio. Quick-Link also features a single package (no external encoders or decoders); time code spread-spectrum RF technology; extremely robust signal utilizing direct sequence spread spectrum coding; standard XLR and much more.

## SENNHEISER



See *Headsets & Headphones Section on Pages 97-100.*

HMD 224

### HMD 224 Super Directional Mic Headphones

The super directional characteristics of the microphone make the Sennheiser HMD 224 system highly suitable for sporting events with close-crowd noises. Headphone response extends from 16 Hz to 20 kHz. Comfort is aided by a total self-weight of only 12.7 ounces.

## BULLETIN BOARD

The Harris Allied Bulletin Board service, on line since 1985, offers hundreds of broadcast oriented files including demos, help files, basic programs, technical help and an on-line E-Mail system for broadcast exclusively.

Scan our **used equipment** listings which are updated bi-weekly. Also take advantage of the **FREE** used equipment exchange listing where you can sell or buy surplus gear directly with other Bulletin



Board users. Read or add to the help wanted and situations wanted classified column listing. Communicate with other engineers worldwide about specific problems and/or suggestions.

Our Bulletin Board service is **FREE**. Of course, your contributions are welcome. Log-on and take a look!

Call the Bulletin Board  
**317-935-0533**



Please FAX this form to request immediate product information from Harris Allied

# InfoFaxx™ Form

**FAX to Harris Allied FAX USA 317-966-0623**

— PLEASE TYPE OR PRINT WITH A BLACK PEN —

**I'd like product information on:**

**My intended use is:**

---

---

---

---

---

---

---

---

---

---

---

---

---

---

---

---

**My need is:**

- Immediate
- Near future
- Within one year
- Information only

**I need:**

- Prices
- Product literature
- Delivery information
- Ideas or help

on: \_\_\_\_\_

---

---

---

---

---

**Please:**

- FAX to me by return
- Airmail to me
- Telephone me
- Visit me

**My Name:** \_\_\_\_\_ **Phone:** \_\_\_\_\_

**My Title:** \_\_\_\_\_ **FAX:** \_\_\_\_\_

**Company/Station:** \_\_\_\_\_

**Street Address:** \_\_\_\_\_

**City:** \_\_\_\_\_ **Country:** \_\_\_\_\_





# PRICE ADDENDUM

Note:

**LIST PRICES ARE MANUFACTURERS RECOMMENDED  
PLEASE CALL OR FAX FOR CURRENT SELLING PRICE**

NOTE: FOR CANADA -ALL U.S. PRICES SUBJECT TO CURRENT EXCHANGE ADJUSTMENT-





**HARRIS  
ALLIED**

