

Z5CD

5kW FM Transmitters

Harris proudly presents a new dimension in FM transmitters with solid-state reliability and performance at the price of vacuum tube technology.

Harris Platinum Z transmitters were developed with the latest Z-axis, three-dimensional electronic design tools to create a compact, no-compromise performance leader without the high price usually associated with higher power solid-state transmitters. Harris Platinum Z FM transmitters with Z-axis design are fourth-generation solid-state transmitters from the industry's acknowledged leader in FM broadcast technology.

Features/Benefits

- ▶ Includes the field-proven Harris DIGIT[®]CD Digital FM Exciter with built-in DSP stereo generator. As the world's first and most popular all-digital FM exciter, the Harris DIGIT CD accepts AES3 digital audio and generates the fully modulated RF carrier totally in the digital domain for the lowest noise and distortion available in any FM transmitter (16 bit digital audio quality).
- ▶ Power output range: 1.25-5kW; up to 5.5kW into a 1.1 or less VSWR.
- ▶ Redundant, autoswitching IPA amplifiers to eliminate a single point of failure.
- ▶ Redundant RF amplifier modules that allow maintenance while the transmitter remains on the air at reduced power ("hot-pluggable" modules).
- ▶ Multiple DC power supplies keep the transmitter on the air even with the loss of a power supply.



Features/ Benefits (cont.)

- ▶ Broadband design to eliminate tuning adjustments from 87 through 108MHz (N+1 capable). Frequency change can be done manually in less than five minutes using simple switch settings, and in less than 0.5 seconds using an optional, external controller.
- ▶ Quick-start design provides full output power, meeting all specifications within five seconds of an "ON" command.
- ▶ Microprocessor based controller for advanced control, diagnostics and display capability. Includes built-in logic and commands for switching between main/alternate DIGIT CD exciters and IPAs.
- ▶ Versatile air cooling design uses either a dual-speed internal fan or an external air system.
- ▶ Dual output power settings are standard.
- ▶ Directional RF sample port provided for customer use.
- ▶ Available for single or three phase mains power, 50/60Hz.
- ▶ Exceeds world safety and performance standards, including ANSI C62.41/IEEE-587. IEC-215 standards are met without interlocks. Manufactured in an ISO-9001 registered facility.

Engineered for Highest Performance

Harris Platinum Z™ FM transmitters are a new, more efficient, value priced FM transmitter line building on the excellent performance of the Harris Platinum Series® FM transmitters. Platinum Z transmitters were designed using the latest Z-axis three-dimensional electronic modeling techniques to provide the highest performance and reliability. The Platinum Z line uses the field-proven basic RF amplifier design of the Harris Platinum Series in a new, smaller and more efficient package.

Harris DIGIT[®]CD Digital FM Exciter

The Harris DIGIT CD FM exciter is supplied as standard equipment with all Platinum Z transmitters. This second-generation DIGIT[®] includes synchronous AM null circuitry, improved stereo signal-to-noise performance and an optional, external carrier frequency synchronization input for use in FM booster applications. The DIGIT CD with its digital input module generates the complete stereo FM waveform in the digital domain, using a digital signal processor (DSP) as a stereo generator and composite limiter, and a 32-bit numerically controlled oscillator (NCO) as a fully digital modulator. Digital techniques allow direct connection of

standard AES3 stereo audio data to the FM exciter to eliminate the distortion and alignment problems of analog paths and analog FM exciters. DIGIT CD is also available with an analog interface module for stations with analog program paths, easily interchangeable with the digital module. DIGIT CD provides true 16-bit digital audio quality for the best on-air broadcast FM sound available today.

PA/IPA Modules

PA modules consist of two independent MOSFET amplifiers. Each PA module has four MOSFET devices mounted on two compact heat spreaders attached to a heatsink assembly. RF modules plug directly into an isolated combiner without using channel-sensitive RF cables. Modules are "hot-pluggable" and can be removed and inserted into an operating transmitter without removing plugs and cables. Each PA module is conservatively rated to produce over 660 watts of output power into a system VSWR of 1.5:1 at up to 50 degrees Celsius ambient temperature at sea level.

The IPA amplifier uses a single pair of MOSFETs from a standard PA module. The second pair will automatically replace the first pair on failure, to keep the transmitter on the air. Any PA module can be used as an IPA module, without modification.

RF Combining

Each MOSFET pair is combined first in groups of eight in a compact, "Z Plane," isolated combiner. True isolation means each module will continue to work into a nominal 50 ohm load regardless of the number of active modules, for almost zero added stress to the amplifiers during fault conditions. The outputs of the 8-way combiners are then combined in a compact 3dB hybrid. The 3dB hybrid provides improved load conditions for the RF modules and tends to absorb power received by the antenna which can reduce the amount of RF intermodulation generated by the transmitter when co-sited with other FM transmitters.

Harmonic Filter

A very efficient harmonic filter is included within the transmitter cabinet. No tuning or adjustment of the filter is required for any carrier frequency, 87-108 MHz.

Controller

A microprocessor-based controller monitors over 100 operating functions of the transmitter and makes intelligent operating decisions based on operating conditions. Detailed system information is available using the front panel diagnostic display. The controller is designed for direct connection to standard remote control systems, and includes an RS-232 serial communications port. The controller stores the last 32 faults with time sequence to aid in system troubleshooting. Faults are reported through the front panel LCD display.

The controller also includes built-in logic and controls for automatic switching to a backup FM exciter and a reserve IPA section. The main controller provides automatic power control, VSWR overload protection, automatic VSWR foldback, RF power soft start, AC restart and diagnostics. Base control functions without the main controller are VSWR protection, IPA protection, transmitter on/off, failsafe, and interlock.

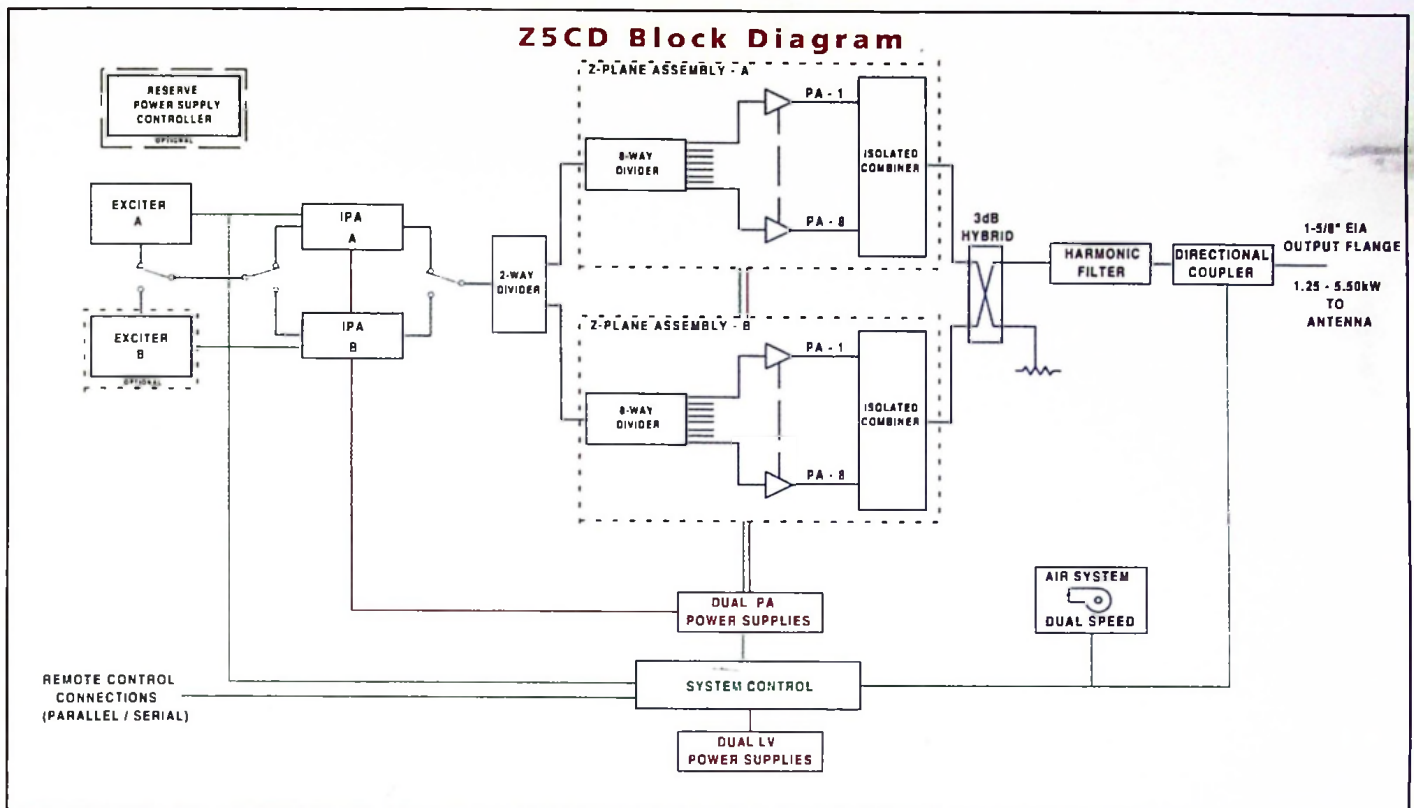

Directional RF Sample Port

Platinum Z FM transmitters provide an RF sample port with over 30dB nominal directivity. A directional RF sample provides more accurate performance measurements by supplying a nearly reflection-free RF sample as a source for external monitoring equipment.

Main Power Supply

Harris Platinum Z power supplies are regulated by reliable tap-changing techniques (non-switching design). This approach provides high conversion efficiency and excellent power factor with very low line harmonics, in an easy-to-service design. The two power supplies are mounted on a roll out mounting plate for complete accessibility.

System Redundancy

Exciters: A reserve, autoswitching exciter is available as an option.

Power Supplies: Harris Z5CD transmitters include dual main power transformers and regulator assemblies as standard equipment. For further reliability, each main power supply serves four of the PAs in each eight PA-group to maximize the net power output available from the transmitter if one supply should fail. The IPA is automatically powered from either power supply for added redundancy.

Power Supply/Controller: A redundant power supply controller is available as an option to add maximum available redundancy to the transmitter power supplies.

IPA: A reserve, autoswitching IPA amplifier is standard. Any of the PA modules can be substituted for a full redundant IPA module to keep the station on the air, as well.

Harris Platinum Z FM transmitters offer the best combination of operating features and specifications available today.

General

- Power Output: 5kW nominal; 1.25-5.5kW type-notified range.
- Output Connector: 1-5/8" EIA flange (female).
- Excitation: Harris DIGIT[®]CD Digital FM Exciter.
- Frequency Range: 87 to 108MHz, digitally programmable in 50Hz increments.
- Frequency Stability: ± 150 Hz, 0°C to 50°C ambient temperature range (using internal frequency reference).
- External Frequency Control: Capable of locking to an external 10MHz reference for use in FM synchronous applications when fitted with optional DIGIT CD Sync Board (992-9850-001). Sync input requirement: 2.82V p-p or TTL level. Sync input connector: BNC female.
- Harmonic/Spurious Output: Meets or exceeds FCC, IC and CCIR requirements.
- Modulation Type: Direct Digital Synthesis using a 32-bit NCO (numerically controlled oscillator).
- Modulation Capability: 208% (± 75 kHz reference standard). Factory programmable in 6dB increments to ± 468 kHz.
- PLL/AFC Overload Characteristics: Immune to carrier dropouts caused by high energy, low frequency modulation (program audio is not applied to the VCO).
- Modulation Indication: Digitally generated peak reading, 0.25% accuracy (at 150% modulation setting), color coded LED display with baseband overmodulation indicator.
- Asynchronous AM S/N Ratio: 55dB minimum below equivalent 100% amplitude modulation by 400Hz using 75 μ s de-emphasis (no FM modulation present).
- Synchronous AM S/N Ratio: 53dB minimum below equivalent 100% amplitude modulation with 75 μ s de-emphasis and 400Hz highpass filter (FM deviation ± 75 kHz by a 1kHz sine wave).

AC Mains Requirement: 190-250VAC, 3-phase, 50/60Hz, 3-wire plus safety ground or 360-415VAC, 3-phase, 50/60Hz, 4-wire or 190-250VAC, 1-phase, 50/60Hz, 2-wire plus safety ground.

Power Consumption (nominal): 7.9kW at 5kW output power.
Power Factor (displacement): 3-phase mains: ≥ 0.95 ; 1-phase mains: ≥ 0.8 .

Altitude: To 3,049m (10,000 feet) elevation above mean sea level.

Ambient Temperature Range: 0-50°C; upper limit derated 2°C per 304.9m (1,000 feet) elevation above mean sea level.

Relative Humidity: To 95%, non-condensing.

Dimensions: 28 1/2" (72.4cm) wide by 36" (91.4cm) deep by 72" (182.9cm) high. Blower assembly adds 13 3/16" (33.5cm) to depth.

Weight: 3-phase: 1,300 pounds (590kg); 1-phase: 1,395 pounds (633kg).

Stereo Performance With Digital Input Module

Input Data Format: AES3-1992 (reference standards: AES5-1984, ANSI S4.28-1984, AES3-1985, ANSI S4.40-1992, and AES3-1992).

Sample Rate: Any in range 32kHz to 56kHz (32, 44.1 or 48kHz typically output from AES3 devices).

Digital Stereo Generator: Complete digital composite stereo waveform generated in the digital domain from incoming AES3 stereo audio data, using a digital signal processor (DSP).

Digital Baseband Composite Limiting: Exclusive DSP "lookahead" techniques for control of peaks before overmodulation can occur. Active with on-board DSP stereo generator in stereo or monaural mode; pilot carrier and SCA signals unaffected. Limiter on/off and limit setting adjustable from 0-18dB either locally or by standard remote control systems.

Pre-emphasis: 0, 25, 50 or 75 μ s, locally selectable.

Stereo Separation (sine wave): 65dB or greater, 10Hz to 15kHz.

Dynamic Stereo Separation (complex waveform): 55dB or greater, 10Hz to 15kHz.

Amplitude Response (L or R): 10Hz to 15kHz, ± 0.2 dB referenced to selected pre-emphasis curve.

FM Signal To Noise Ratio (L or R): 83dB below 100% modulation at 400Hz; measured in a DC to 22kHz bandwidth with 75 μ s de-emphasis and DIN "A" weighting. Does not exhibit the subsonic noise associated with analog exciters.

Stereo Total Harmonic Distortion: 0.005% or less for any modulating frequency from 10Hz to 15kHz; measured in DC to 22kHz bandwidth with 75 μ s de-emphasis.

Intermodulation Distortion (L or R): CCIF: 0.02% (14/15kHz 1:1), SMPTE: 0.025% (60 and 7000Hz 1:1).

Transient Intermodulation Distortion (DIM) (L or R): 0.005% (2.96kHz square wave/14kHz sine wave modulation).

Linear Crosstalk: L+R to L-R and L-R to L+R due to amplitude and phase matching of L&R channels (DC-15kHz): 85dB below 100% modulation reference.

Non-Linear Crosstalk: L+R to L-R and L-R to L+R due to distortion products: 75dB below 100% modulation reference, DC-15kHz.

RBDS/RDS Synchronizing Signal: 19kHz quasi-sine wave, nominal 5.6V p-p, AC coupled, 100 ohm output impedance (unbalanced); for use by customer-supplied, external generator. BNC female connector.

Stereo/Monaural Mode Control: Selectable locally or by standard remote control systems. Zero amplitude pilot monaural mode.

Emergency Analog Composite Mode: Switchable locally or by standard remote control systems to mute the on-board DSP stereo generator and accept analog composite stereo on SCA Port #2. Nominal input sensitivity (all SCA ports in this mode): 3.5V p-p (1.24V RMS) for ± 75 kHz deviation. FM signal to noise ratio: 85dB below 100% modulation. Total composite harmonic distortion: 0.02%.

Composite Input Performance With Analog Input Module

Inputs: Two: XLR female balanced (switchable, composite or monaural), and BNC female unbalanced.

Input Impedance: Balanced/unbalanced: 10,000 ohms nominal (resistive).

Input Level: 3.5V peak-peak (1.24V RMS) nominal for ± 75 kHz deviation.

FM Signal To Noise Ratio: 16 bit quantization (96dB) below ± 75 kHz deviation at 400Hz; measured in a DC to 100kHz bandwidth with 75 μ s de-emphasis; DIN "A" weighting. Does not exhibit the subsonic noise associated with analog exciters.

Amplitude Response: ± 0.01 dB, DC to 53kHz; ± 0.25 dB, 53kHz to 100kHz.

Total Harmonic Distortion: 16 bit linearity (96dB or 0.0016% THD) over stereo sub band (DC to 53kHz).

Intermodulation Distortion: CCIF: 0.008% (14/15kHz 1:1); SMPTE: 0.008% (60/7000Hz 1:1).

Transient Intermodulation Distortion (DIM): 0.005% (2.96kHz square wave/14kHz sine wave modulation).

Slew Rate: 9V/ μ s, symmetrical.

Group Delay Variation: ± 5 ns, DC to 53kHz, ± 50 ns, 53kHz to 100kHz.

Phase Response Variation: $\pm 0.1^\circ$ from linear phase, DC to 53kHz.

Analog Stereo and SCA Performance

NOTE: Analog stereo and SCA performance with the DIGIT[®]CD exciter is defined almost entirely by the program link and external generators.

All specifications referenced to any single output frequency (87-108MHz) nominal rated output power, and 50 ohm, isolated, non-reactive load.

Specifications defined in a laboratory environment with high grade source and demodulation equipment. Standard factory measurement does not include all listed items.

Specifications subject to change without notice.

HARRIS

next level solutions

Broadcast Communications Division | 4393 Digital Way | Mason, OH USA 45040
phone: 513-459-3400 | email: broadcast@harris.com | www.harris.com



Copyright ©2000 Harris Corporation
ADV. 843E 05/00