

# **PRISM II FM**

## **USER'S MANUAL**

January 1991

**GENTNER ELECTRONICS CORPORATION**  
1825 Research Way  
Salt Lake City, Utah 84119

(801) 975-7200  
Fax (801) 977-0087

**Prism II FM User's Manual**

Copyright © 1991 by Gentner Electronics Corporation. All rights reserved. No part of this manual may be reproduced in any form or by any means without written permission from Gentner Electronics Corporation.

Printed in the United States of America. Gentner Electronics Corporation reserves price and specification privileges.

Optimod 8100(A)<sup>®</sup> and Optimod 8000<sup>®</sup> are registered trademarks of Orban Associates, Inc.  
Stereo Maxx<sup>®</sup> is a registered trademark of Modulation Sciences Inc.

---

## Table of Contents

---

### SECTION 1

<b>INTRODUCTION.....</b>	<b>1-1</b>
TECHNICAL SPECIFICATIONS.....	1-2
WARRANTY.....	1-4

### SECTION 2

<b>INSTALLATION AND ADJUSTMENT OF THE PRISM II FM .....</b>	<b>2-1</b>
DESCRIPTION .....	2-1
THE M-102 PROCESSOR.....	2-2
FRONT PANEL INDICATORS .....	2-4
CONTROLS .....	2-6
REAR PANEL CONNECTIONS .....	2-7
INSTALLATION.....	2-8
ELECTRICAL CONSIDERATIONS.....	2-8
MECHANICAL CONSIDERATIONS .....	2-10
USE OF THE PHASE ROTATOR .....	2-11
DISABLING THE PHASE ROTATOR .....	2-11
USING THE PHASE ROTATOR WITH THE ORBAN OPTIMOD .....	2-12
ADJUSTMENT OF THE PRISM II FM .....	2-12
SETTING THE GATE CONTROL .....	2-14
SETTING THE MIX LEVELS.....	2-14
ESTABLISHING THE L-R CHANNEL NULL .....	2-18
SETTING THE DENSITY CONTROL FOR RADIO APPLICATIONS.....	2-21
SETTING THE DENSITY CONTROL FOR TELEVISION APPLICATIONS .....	2-22
SPECTRAL MIX ADJUSTMENT WITH THE ORBAN 8100 .....	2-23
THE GENTNER REPLACEMENT CARD FIVE (RCF-1).....	2-23
SUGGESTED ADJUSTMENT OF THE ORBAN 8100 (FM APPLICATIONS) .....	2-24
RECOMMENDED SETTINGS FOR THE STOCK OPTIMOD 8100.....	2-24
RECOMMENDED SETTINGS OF THE GATE THRESHOLD, BASS COUPLING, AND RELEASE TIME CONTROLS FOR FM APPLICATIONS.....	2-25
REMOVING THE PHASE ROTATORS IN THE 8100 (FM APPLICATIONS) .....	2-26
OPERATION WITH THE ORBAN 8000 (FM APPLICATIONS).....	2-27
RECHIPPING THE ORBAN 8000 (FM APPLICATIONS).....	2-28
EVALUATION METHODS WHEN USING THE PRISM II FM IN CONJUNCTION WITH THE OPTIMOD 8100 OR THE OPTIMOD 8000 (FM APPLICATIONS) .....	2-30

BYPASS MODE OPERATION ..... 2-31  
     ADJUSTING THE GAIN OF THE BYPASS MODE ..... 2-32  
 USE WITH FM EQUIPMENT ..... 2-32  
     EXCITERS ..... 2-32  
     COMPOSITE CLIPPERS ..... 2-32  
 THEORY OF OPERATION ..... 2-34  
 INTERNAL ADJUSTMENTS ..... 2-36  
 SEPARATE MUSIC AND VOICE PROCESSING SYSTEMS ..... 2-37

**SECTION 3**

**TROUBLESHOOTING THE PRISM II FM ..... 3-1**  
     POWER SUPPLY ..... 3-1  
     AUDIO PROCESSOR BANDS ..... 3-1  
     SYMPTOM: NO OUTPUT ..... 3-2

**SECTION 4**

**RCF-1 REPLACEMENT CARD FIVE ..... 4-1**  
     INSTALLATION ..... 4-1  
         RECOMMENDED EQUIPMENT ..... 4-1  
         INSTALLATION PROCEDURE ..... 4-2  
     ADJUSTMENT ..... 4-4  
         THE RCF-1 CONTROLS ..... 4-4  
         ADJUSTING THE SYSTEM ..... 4-5  
     THEORY OF OPERATION ..... 4-7  
     TROUBLESHOOTING ..... 4-9

**APPENDIX A**

**RECOMMENDED SETTINGS ..... A-1**  
     SETUP LOG ..... A-2

**APPENDIX B**

**SCHEMATICS AND BLOCK DIAGRAMS ..... B-1**

---

## Illustrations

---

Figure 2-1	Recommended FM Configurations .....	2-2
Figure 2-2	PRISM II FM Block Diagram .....	2-3
Figure 2-3	M-102 Block Diagram.....	2-3
Figure 2-4	Front Panel Display, 2 Bands.....	2-4
Figure 2-5	PRISM II FM Control Panel .....	2-6
Figure 2-6	AC Power Wiring Harness.....	2-9
Figure 2-7	Phase Rotator Jumper Location.....	2-12

# SECTION 1

## INTRODUCTION

---

The **PRISM II FM** is a dynamic range control device which is typically used in broadcast FM audio chains. The **PRISM II FM** also finds use in television audio chains and sound studios.

Section 2, entitled Installation, contains the instructions for both setting up your **PRISM II FM** and operating your **PRISM II FM**.

Appendix A of this manual contains some recommended starting points for setting the Mix Level controls and also contains a form for recording the settings of the front panel controls on the **PRISM II FM**. Because audio processing is so subjective and many hours of listening are typically used to "zero in" on a unique sound, it is strongly recommended that the settings of all controls be recorded after each change, along with appropriate comments.

Appendix B of this manual contains a complete set of schematics for the **PRISM II FM** to facilitate field service where qualified technical personnel are available.

## 1.1 TECHNICAL SPECIFICATIONS

---

The following are static (steady-state) test data. Because broadcast audio processing systems are dynamic (non-steady-state) systems, the performance of such a device cannot be accurately reflected here. The proper method for evaluating audio processing equipment is by in-circuit evaluation and testing. The following is for informational purposes only.

### Description

The **PRISM II FM** is a digitally controlled audio processor for broadcast applications.

### Topology

Parallel discriminate

### Number of Bands

Four

### Crossover Frequencies

153 Hz, 860 Hz, and 4900 Hz  
(each band is 2 1/2 octaves wide)

### Input Impedance

600 ohm resistive terminating  
(can be changed to 10K bridging)

### Input Level

0 dBm to +12 dBm as shipped from factory  
(can be modified to work with inputs as low as -10 dBm)

### Output Impedance

Dynamic Source Impedance:

with lightning protection circuit operational: 200 ohms  
with lightning protection circuit deactivated: <1 ohm

Recommended load:

600 ohms or greater

**Output Level**

Nominal operating level:

+10 dBm

At clip point:

24 volts peak-to-peak, +20.8 dBm

**Harmonic Distortion**

<0.05% at +10 dBm output, 1 kHz

**Signal to Noise Ratio**

-80 dB below +10 dBm nominal output

**Dimensions**

Height:

1 3/4 inches (4.45 cm)

Width:

19 inches (48.3 cm)

Depth:

12 1/4 inches (31.1 cm)

**Weight**

10.5 pounds (4.8 kg)

**Power Requirements**

120/240 VAC, 50/60 Hz

Power Pull

Power up 30 W

Regular operation 15-20 W



---

## 1.2 WARRANTY

---

The Gentner warranty agreement on the following page is effective as of the date of receipt by the purchaser of the **PRISM II FM**. This warranty shall not be effective unless Gentner is notified in writing by the purchaser of the receipt of the unit and the unit's serial number.

A Gentner Warranty Registration Card is supplied with each **PRISM II FM** unit. Use this card to notify Gentner of your purchase of the **PRISM II FM** and its serial number.

# WARRANTY

GENTNER ELECTRONICS CORPORATION (Manufacturer) warrants that this product is free of defects in both materials and workmanship. Should any part of this equipment be defective, Manufacturer agrees, at its option, to:

A. Repair or replace any defective part free of charge (except transportation charges) for a period of one year from the date of the original purchase, provided the owner returns the equipment to Manufacturer at the address set forth below. No charge will be made for parts or labor during this period.

B. Furnish replacement for any defective parts in the equipment for a period of one year from the date of original purchase. Replacement parts shall be furnished without charge except labor and transportation.

This Warranty excludes assembled products not manufactured by Manufacturer whether or not they are incorporated in a Manufacturer product or sold under a Manufacturer part or model number.

**THIS WARRANTY IS VOID IF:**

A. The equipment has been damaged by negligence, accident, act-of-God or mishandling, or has not been operated in accordance with the procedures described in the operating and technical instructions; or,

B. The equipment has been altered or repaired by other than Manufacturer or by authorized service representative of Manufacturer; or,

C. Adaptations or accessories other than those manufactured or provided by Manufacturer have been made or attached to the equipment which, in the determination of Manufacturer, shall have affected the performance, safety, or reliability of the equipment; or,

D. The equipment's original serial number has been modified or removed.

NO OTHER WARRANTY EXPRESS OR IMPLIED, INCLUDING WARRANTY OF MERCHANTABILITY OR FITNESS FOR ANY PARTICULAR USE, APPLIES TO THE EQUIPMENT, nor is any person or company authorized to assume any warranty for Manufacturer or any other liability in connection with the sale of Manufacturer products.

Manufacturer does not assume any responsibility for consequential damages, expenses or loss of revenue or property, inconvenience or interruption in operation experienced by the customer due to a malfunction in the purchased equipment. No warranty service performed on any product shall extend the applicable warranty period.

In case of unsatisfactory operation, the purchaser shall promptly notify Manufacturer at the address set forth below, in writing, giving full particulars as to the defects or unsatisfactory operation. Upon receipt of such notice, Manufacturer will give instructions respecting the shipment of the equipment, or such other matters as it elects to honor this warranty as above provided. This warranty does not cover damage to the equipment during shipping and Manufacturer assumes no responsibility for such damage. All shipping costs shall be paid by customer.

This warranty extends only to the original purchaser and is not assignable or transferable.

**GENTNER**  
ELECTRONICS  
CORPORATION

1825 Research Way  
Salt Lake City, Utah 84119  
Telephone: (801) 975-7200  
Facsimile: (801) 977-0087

## SECTION 2

# INSTALLATION AND ADJUSTMENT OF THE PRISM II FM

---

### 2.1 DESCRIPTION

---

The Gentner **PRISM II FM** is a high-performance multi-band audio processor for broadcast use and other applications where sophisticated program handling is required. The **PRISM II FM** utilizes four intelligent, digitally controlled processor cards to achieve high apparent loudness while producing few processing artifacts. This absence of undesirable subliminal listener aggravation reduces listener tune-out, producing higher quarter-hour ratings.

If the transmitter and studio are at separate locations, the preferred placement for the **PRISM II FM** is at the studio. This prevents accidental over-driving of the telephone lines or STL and provides the maximum signal-to-noise ratio over the program circuit.

The unit is completely self-contained in a single 1 $\frac{3}{4}$ " rack-height enclosure and will operate normally in severely hostile electrical environments. Extensive RFI filtering and a three-part lightning protection circuit are standard on all conductors leaving the chassis.

The input impedance is factory-wired for 600 ohms resistive, but can be changed to 10K (nominal) bridging with the removal of a single resistor. The output will drive a 600 ohm balanced load to +10 dBm nominal program level. All controls are front panel mounted. There are no controls on the rear panel or inside the unit. Complete setup takes less than two minutes and requires no test equipment other than a simple VOM. The internal PINK NOISE alignment generator is flat within plus or minus 0.8 dB.

The **PRISM II FM** is arranged in a motherboard/daughterboard fashion. There are a total of nine circuit boards of six different types. There are four M-102 digitally controlled processors and one each of the following: motherboard, display board, control board, RFI filter/lightning protection board, and power supply board. Each board, including the motherboard, can be easily removed.

For FM broadcast, the **PRISM II FM** may be used in conjunction with the Gentner Lazer, Orban 8100, 8000, or other high-quality limiter/stereo generator combination. See Figure 2-1 on the next page.

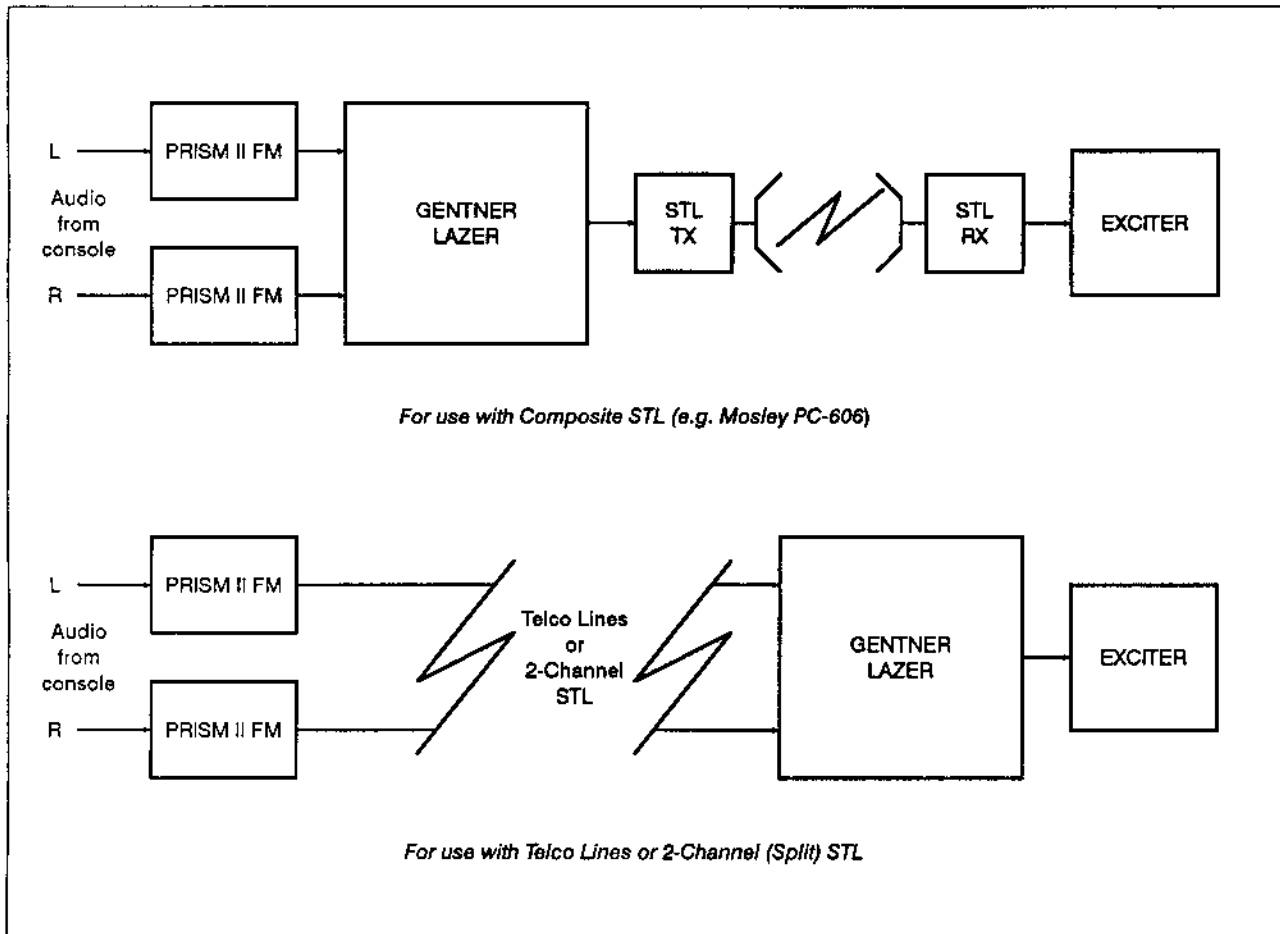

Figure 2-1  
Recommended FM Configurations

## 2.2 THE M-102 PROCESSOR

The organization of the **PRISM II FM** is shown in Figure 2-2. At the heart is four digitally controlled, model M-102 processor boards. The input and output signals of each of the M-102s are level-detected as shown in Figure 2-3. This information, plus reference voltages from the motherboard, is considered by the CMOS digital logic. Taking into account a knowledge of past events, the logic chooses what change (including no change) to make in the gain of the variable gain element.

The M-102 implements a hardware digital algorithm. The instruction set is determined by non-volatile CMOS devices and the arrangement of their interconnections on the PC board (there is no central microprocessor). This eliminates the problems of keeping the memory alive in the event of a power outage and of using sensitive RAM memory in a harsh electrical environment.

It is important to point out that the audio does not pass through any active device on the M-102s. The audio merely loops onto the M-102, through the variable attenuator, and back onto the motherboard. The remainder of each M-102 is sidechain.

The capacitors which determine the M-102 attack and release speeds are located on the motherboard, permitting the use of identical M-102s in different bands. When an M-102 board is inserted, it is automatically connected to whatever time-constant components are appropriate for that frequency band. As a result, only one spare board is required as a result since all M-102 boards are identical.

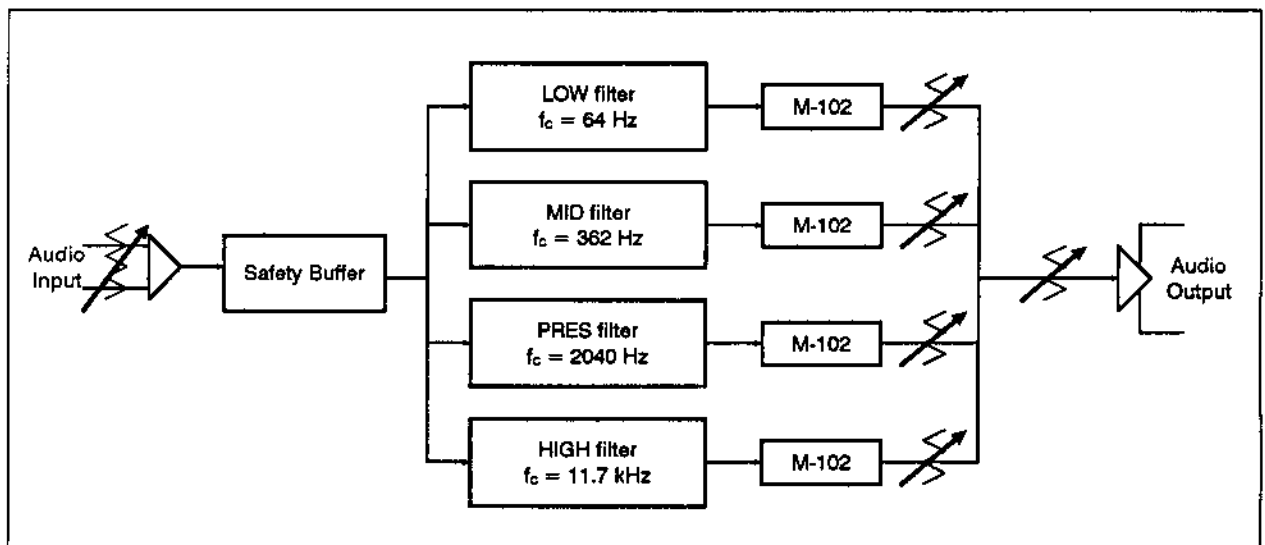

Figure 2-2  
PRISM II FM Block Diagram

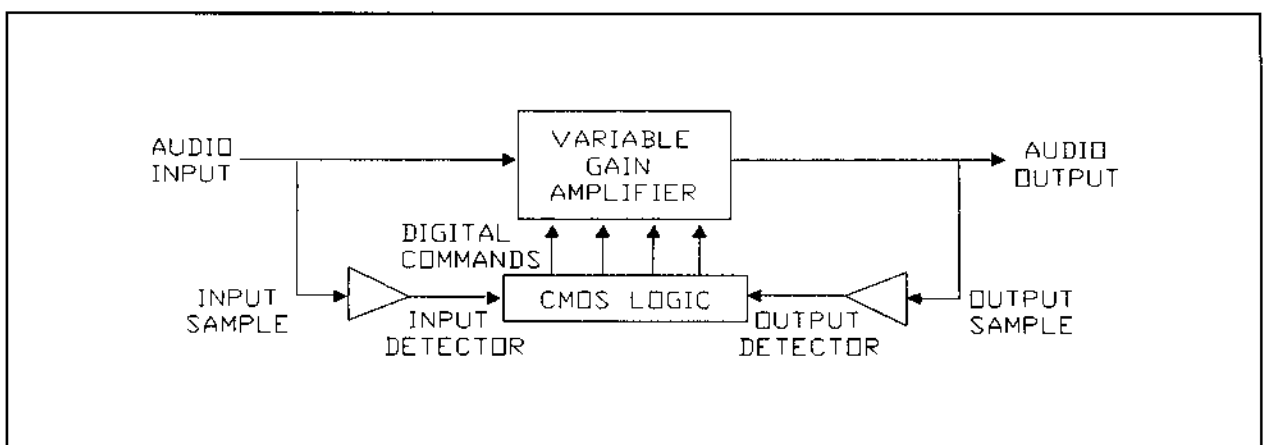

Figure 2-3  
M-102 Block Diagram

## 2.3 FRONT PANEL INDICATORS

The action of each of the four digitally controlled processors is completely described by the front panel indicator LEDs. Both the immediate action being implemented, and where it is in its range of action, are called out. Ten LEDs are arranged in bar graph fashion along the top of each band's display area. The four leftmost LEDs in each group are green and indicate expansion. The next five LEDs in each bar graph are yellow and represent compression. The LED furthest to the right in each bar graph is red and also indicates compression. Its red color signifies the maximum amount of compression possible in that band without activating the SAFETY BUFFER.

With no signal, each processor will recover to the QUIESCENT position (the center of the bar graph). As the number of LEDs is even, there is not an LED at the exact midpoint. The display will come to rest on the first yellow LED.

Each processor has a range of 20 dB from maximum expand to maximum compress. Each LED therefore represents approximately 2 dB of gain change.

Each band has five additional LEDs as status indicators. From left to right, they are labeled Q (quiescent), S (signal), E (expand), C (compress), and P (peak).

The SIGNAL LED is just that; it lights when there is signal present in that band, and goes out immediately when there is none. This function is frequently called the "gate." The threshold between what amplitude is considered signal and what lesser level is not, is controlled by the GATE control. The interaction between this LED and control is described more fully in "Adjustment of the PRISM II FM" on page 2-12. The processor will expand or compress only when there is signal present and the SIGNAL LED is lit.

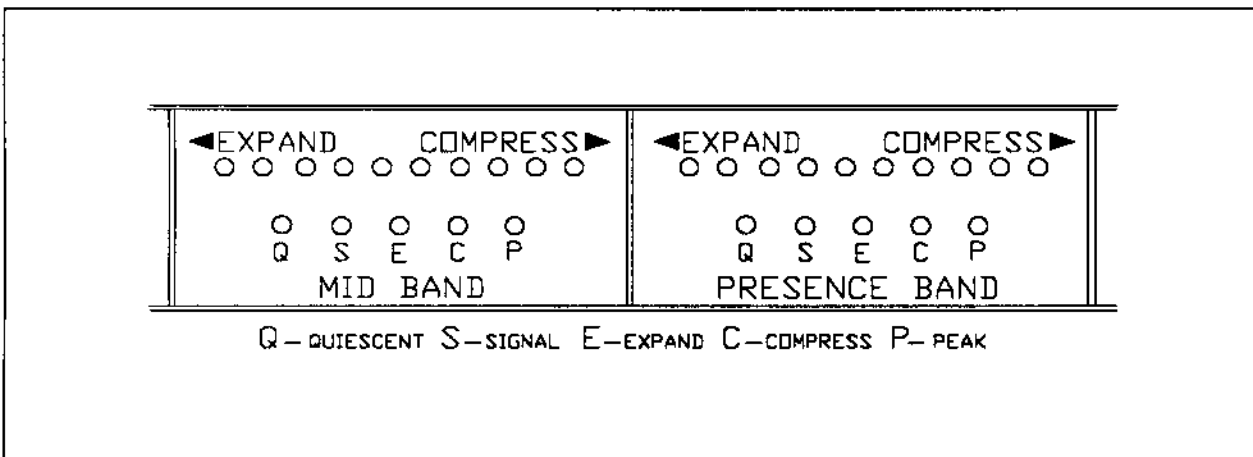

Figure 2-4  
Front Panel Display, 2 Bands

If the signal in a particular band falls below the threshold and the SIGNAL LED goes out, the gain of that band will freeze. The processor will then wait approximately 1.7 seconds without changing gain. If the signal has not returned by the end of that period, the QUIESCENT LED will light and the gain will slowly recover to the QUIESCENT position. At the instant the signal does return, the SIGNAL LED will relight, and the QUIESCENT LED will go out.

The EXPAND and COMPRESS LEDs signify, respectively, that the processor is increasing gain and decreasing gain. In normal operation, they will flash back and forth. The degree of activity of these two LEDs is controlled by the DENSITY control. Increasing the setting of the DENSITY control increases the activity of these LEDs and vice versa. See "Adjustment of the PRISM II FM" on page 2-12, for a more complete description of this interaction.

The PEAK LED signifies that a sudden transient has occurred which threatens to flatter the amplifier following the individual processor (U302A, U303A, U304A or U305A). The magnitude of the peak is such that the COMPRESS circuit may not respond quickly enough to prevent the flattopping and attendant distortion. At this time the PEAK circuit acts to prevent the possible distortion. Under normal operation, this LED will flicker frequently but will not remain lit for any sustained period.

There is a wealth of information available in the LED display. A few minutes of watching them while listening to familiar program input will greatly help in understanding their action.

Also, there are four status LEDs which reflect the operation of the overall PRISM II FM. They are marked BUFFER FULL, BUFFER ACTIVE, +15V, and -15V.

The SAFETY BUFFER is a broadband, variable-gain element preceding the point where the signal is split into four bands. Decreasing the gain of this stage will decrease the level fed to all four M-102s. Normally, this stage will operate at maximum (unity) gain. If the input level increases to the point where one of the four M-102s reaches maximum compression (the bar graph reaches the red COMPRESS LED on the right), the broadband stage will reduce its gain and the input level to the M-102s. The BUFFER ACTIVE LED will light to indicate that the safety buffer has acted to protect the following stages.

If driven beyond its control range, the bar graph for an M-102 card will blank out. This is an intended function designed to attract attention to the condition. It in no way reflects an equipment malfunction or damage to the unit.

The SAFETY BUFFER has a range of 6 dB. In the event that the input level is so large as to require this full amount of attenuation, the BUFFER FULL LED will light to indicate that the PRISM II FM is no longer able to protect itself. Any further input level increase will result in distortion. The BUFFER ACTIVE LED will light only infrequently but is no cause for alarm when it does. While it indicates that the input level to the PRISM II FM is higher than normal, it also indicates that the unit has taken corrective action to compensate for this condition. The BUFFER FULL LED, on the other hand, should never light. If it does, it indicates gross overdriving, and the input level should be reduced.

2.4 CONTROLS

All controls for the **PRISM II FM** are mounted on the front panel, easily accessible behind the removable name plate. There are two toggle switches and nine potentiometers. See Figure 2-5.

The switches are **PINK NOISE**, which turns on the internal calibration generator, and **BYPASS MODE** (formerly the **PROOF MODE**), which bypasses the processors to permit equipment setup. As activation of either of these functions is undesirable while the unit is on line, the switches are recessed to prevent accidental use. The toggles can easily be manipulated with the end of a small screwdriver when needed.

The potentiometers are broken into three functional groups. The first group serves simply to adapt the **PRISM II FM** to its surroundings. It contains the **INPUT GAIN**, **BYPASS GAIN**, and **OUTPUT GAIN** controls.

The second group contains the **MIX LEVEL** controls: **LOW**, **MID**, **PRESENCE**, and **HIGH**.

The last group contains the **DENSITY** and **GATE** controls. The **DENSITY** control is ganged to all four M-102 processors and controls the degree of action which they will take. When this control is at a low setting the **PRISM II FM** serves as an intelligent but gentle program control device very desirable for the aural channel of television. Further

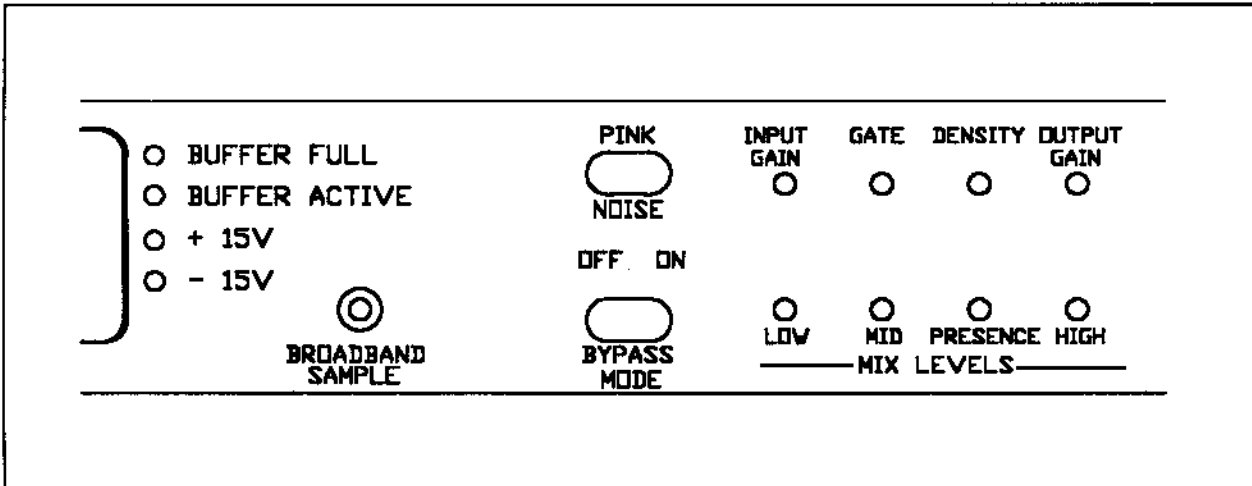

Figure 2-5  
PRISM II FM Control Panel

clockwise, the **DENSITY** control will produce a very dense (but not fatiguing) output to maximize the coverage of FM broadcast.

This single control smoothly and harmoniously performs the same transformation which, on other processors, might require several controls to change attack times,



release times, and compression ratios. It does, in fact, change the whole "character" of the **PRISM II FM**.

The **DENSITY** control is described in more detail in "Theory of Operation" on page 2-34.

The **GATE** control sets the arbitrary threshold which determines when the **SIGNAL LED** will light. Signal inputs to each band above this level will be considered desired signal. Inputs below this level will be ignored. Like the **DENSITY** control, this control adjusts all four **M-102s** simultaneously. Note that each of the four bands is individually gated, that is, one may gate off while the other three do not.

A station with low ambient noise (soundproofing and good signal-to-noise ratio), will probably use a relatively low setting of the **GATE** control. A station with higher ambient noise (due possibly to lower quality cartridge tape or air conditioner noise, etc.), will likely use a higher setting.

The **BYPASS GAIN** control sets the output level when the unit **BYPASS MODE** switch is ON. See "Bypass Mode Operation" on page 2-31.

---

## 2.5 REAR PANEL CONNECTIONS

---

Interconnection between the **PRISM II FM** and the outside world is accomplished by way of a 12-terminal barrier strip located on the rear panel. In addition to input and output, the **AGC** voltage of each of the bands is available on the strip for stereo strapping. The far right terminal (#12) is not connected and may be used for auxiliary connections.

Each of the conductors at this barrier strip is thoroughly **RFI**-shielded and transient-suppressed inside the unit.

When used in a stereo application, it is possible to stereo strap two **PRISM II FM**s so that the gain of each of the bands tracks with the gain of the same band in the other channel. This facility is included for the purist who desires it, but it is not recommended in most applications.

In addition to its normal functions of level control and dynamic noise reduction, the **PRISM II FM** enhances the spatial dimension of program material. This is a major point. The effect, which is very pleasing, is immediately noticeable to even the most untrained ear. The perception is that there is more depth and dimension to the music. Strapping the gains of the channels together reduces the **PRISM II FM**'s ability to produce this effect, and is therefore not recommended. Unstrapped or independent action of the units will not produce "platform motion" or other negative processing artifacts. Extensive on-air use shows that independent action produces no negative effects.

The power line fuse is located on the left side of the rear panel. A 1/4 amp slow-blow fuse is supplied with the unit for use on 120 VAC. This should be replaced with a 1/8 amp slow-blow fuse if the unit is rewired for use with 240 VAC.

---

## 2.6 INSTALLATION

---

### 2.6.1 ELECTRICAL CONSIDERATIONS

---

For stations with separate studio and transmitter sites, the preferred placement of the **PRISM II FM** is at the studio. This protects the telephone lines or STL from uncontrolled levels and eliminates the need for another, less intelligent, processor to do the same. The **PRISM II FM** is intended to receive completely unprocessed audio direct from the audio console or automation machine. The placement of any other processing or preparation device before the **PRISM II FM** will greatly hinder its ability to respond properly to the program.

The **PRISM II FM** integrates about 6 dB of "Burwen-style" noise reduction into the operation of the HIGH band processor. Many audio processors accentuate record noise and tape hiss. Noise "suck-up" or "swish-up" artifacts are most noticeable during record fades.

By contrast, the **PRISM II FM** actually improves the signal to noise ratio of marginal material. Sensing the fade, it reduces the HIGH band gain, masking the poor quality of the source material.

Proper operation of this function is dependent upon the **PRISM II FM** having immediate knowledge of the fade. Placing another variable-gain device between the console and the **PRISM II FM** will render this function inoperative and is discouraged.

When echo and reverb devices are used in the air-chain, these devices should be placed before the **PRISM II FM**. Standard reverb and echo devices do not include variable gain devices and will not impair the proper operation of the noise reduction feature.

The **PRISM II FM** is supplied from the factory ready to use with a 120 VAC 50/60 Hz power source (unless otherwise marked). The **PRISM II FM** can be changed to accept a 240 VAC 50/60 Hz power source. To change the power input follow the procedure below. Refer to Figure 2-6 on the next page.

1. DISCONNECT THE **PRISM II FM** FROM AC POWER. Unplug the electrical power cable from the rear panel.
2. Remove the lid by removing the flat-head machine screws.
3. Locate the AC power wiring harness. Looking from the front of the unit the harness is on the right side towards the rear.
4. For 120 VAC operation connect the harness to the white molex connector.
5. For 240 VAC operation connect the harness to the red molex connector.
6. Replace the lid and re-apply AC power.

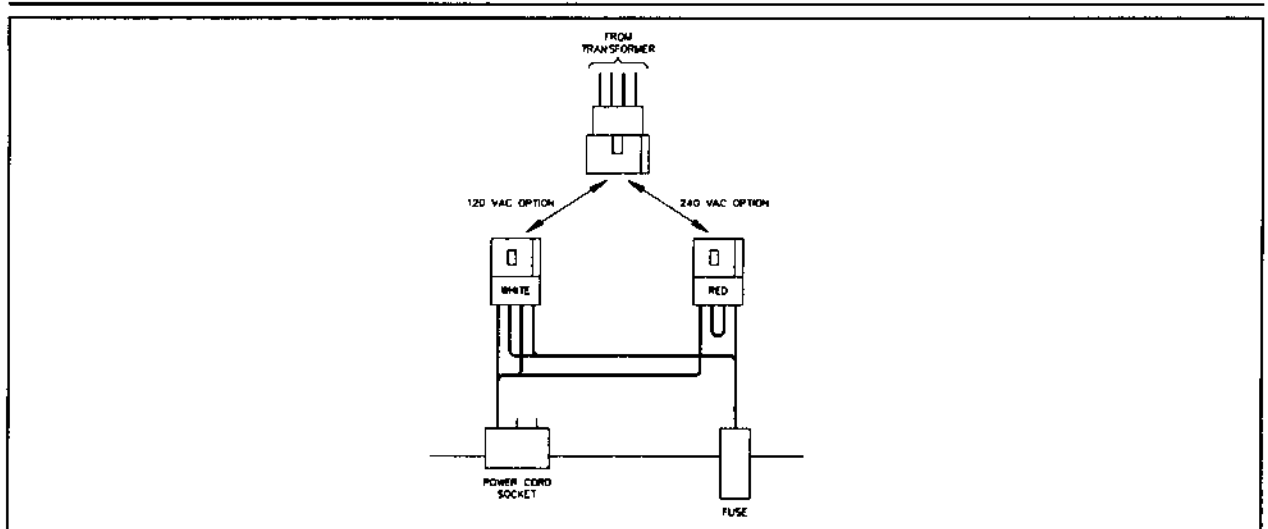

Figure 2-6  
AC Power Wiring Harness

All units are shipped from the factory with the input wired for 600 ohms resistive, terminating. Where the signal source is already terminated, the input can be converted to 10K (nominal) bridging by removing R303 on the motherboard. To find this resistor do the following:

1. Locate the 16-pin DIP header which passes from the motherboard through the rear partition.
2. Locate the group of four resistors directly in front of it. R303 is in this group of four and has a value of 180 ohms.

The gain of the input stage is such that proper operation will result with input levels between 0 dBm and +12 dBm. For lower input levels, the input gain can be increased by increasing the value of R308 and R309. These resistors are both 33K on units with serial numbers over 505.

Higher input gain may be useful to permit the use of passive telephone line equalizers where the PRISM II FM is mounted at the transmitter. For input levels of -10 to 0 dBm nominal, both should be replaced with resistors of approximately 100K. The precise value is not critical so long as the values of the two new resistors match each other within 1%. Differences in value of over 1% will sacrifice the common-mode rejection performance of the unit. Do not use resistors of greater than 100K for R308 and R309. While the 100K value is 100% stable (100K was the factory-installed value for the first 505 units produced), larger values will result in self oscillation. For input levels lower than -10 dBm, use an external line amplifier or use BRIDGING INPUT mode (remove R303).

The input stage operates in full differential mode, that is, it responds only to the difference between the two input terminal voltages, not the absolute value of either. As a result, either input terminal may be grounded with no ill effects.

The balanced output is actually two separate single-ended outputs, operating 180 degrees out of phase. If an unbalanced output is desired, use either output terminal with reference to the output ground. Do *not* ground either of the output terminals. The output stage is a Signetics NE5532 and will produce a nominal program output of +10 dBm, while providing ample headroom to pass transients without clipping. The absolute output voltage at hard clipping is about 9 volts either side of ground. This is more than is required to drive most broadcast equipment.

For those rare instances where additional output is required, the absolute output voltage can be raised from 9 volts to approximately 12 volts by connecting jumpers across R330 and R331. These are 100 ohm, 1/2 watt resistors and are located about an inch to the right of the violet test point on the motherboard. These resistors are part of a very effective surge suppression circuit which protects the NE5532 output stage from external transients, as may be encountered when the **PRISM II FM** is used to drive a telephone line.

Because of the danger of external transients, these resistors should not be jumpered out if the unit is used to drive telephone lines. Because of the signal level limitations of telephone lines, however, logic dictates this is not one of the applications where additional output level is required.

If you are installing a **PRISM II FM** to drive telephone lines and it was acquired second-hand or is being moved from another location in the program chain, check to make certain these resistors are in the circuit.

Connect the signal source to the rear panel barrier strip using a well shielded cable intended for broadcast use such as Belden 8451. Connect the output using a similar cable.

### **2.6.2 MECHANICAL CONSIDERATIONS**

---

The **PRISM II FM** requires no regular maintenance or adjustment. As a result, it can be mounted in practically any rack convenient to the program signal path. This could be in the studio itself, a central master control room, or if the transmitter and studio are together, in a transmitter equipment rack. It is not necessary, except for repairs, to remove the top cover or to remove the entire unit from the rack. As a result, it may be mounted in practically any location where the front panel is easily accessible. Two test points, TP306 and TP307, are accessible through holes in the top of the cover. Access to these holes may be required during initial adjustment.

Sufficient slack in the input and output audio cables should be provided so that the **PRISM II FM** can be slid partially out of the rack for access to these holes.

There are no ventilation holes on either the top or the bottom of the **PRISM II FM**. It may be mounted directly above or below any other piece of equipment, except where it may interfere with ventilation of the other equipment.

The **PRISM II FM** should not be mounted in a strong induction field, such as that found in the rack space directly below a Continental 510R-1 (Collins 310Z-2) exciter.

Mount the unit in the desired rack using the hardware provided. If the installation is temporary, such as for evaluation, and only two screws are being used, choose the bottom two (do *not* employ a diagonal two-screw mounting technique).

---

## 2.7 USE OF THE PHASE ROTATOR

---

The purpose of the Phase Rotator is to increase the modulation level by insuring that positive and negative peaks of program audio are of equal amplitude. The Phase Rotator is recommended for all applications.

Although most recorded program material and live female voice signals are fairly symmetrical, live male voices tend to be very asymmetrical. The Phase Rotator implements an inaudible, linear process to remove asymmetry from the incoming program audio. As will be shown, this provides significant benefits whether the station intends to transmit symmetrical or asymmetrical positive peak modulation.

It should be noted that the Phase Rotator is acoustically transparent and does not detract from low frequency, transient response as do some phase rotators of other designs. The Phase Rotator employs a complex conjugate pair of poles near the frequency axis where some designs employ simple poles on the real axis. While these other designs produce anticipated flat response to steady-state, sinusoidal inputs, it can be demonstrated mathematically and acoustically verified that the bass transient response of the other designs is significantly compromised.

An asymmetrical input wave passed through a phase rotator has the phase relationship of critical odd-order harmonics modified in such a way that the output wave has equal positive and negative peak amplitudes. For FM applications where the transmitter is not capable of asymmetrical modulation no further consideration of wave symmetry or polarity is necessary.

### 2.7.1 DISABLING THE PHASE ROTATOR

---

The PRISM II FM is shipped from the factory with the Phase Rotator enabled—the jumper is in the IN position. To disable the Phase Rotator follow the procedure below.

1. DISCONNECT THE PRISM II FM FROM AC POWER. Unplug the electrical power cable from the rear panel.
2. Remove the lid by removing the flat-head machine screws.
3. Locate the Phase Rotator Jumper as shown in Figure 2-7. When the Phase Rotator is enabled the jumper is in the right-hand position with the jumper covering pins 2 and 3.
4. Move the jumper to the BYPASS position. This is the left-hand position with the jumper covering pins 1 and 2.
5. Replace the lid and re-apply AC power.

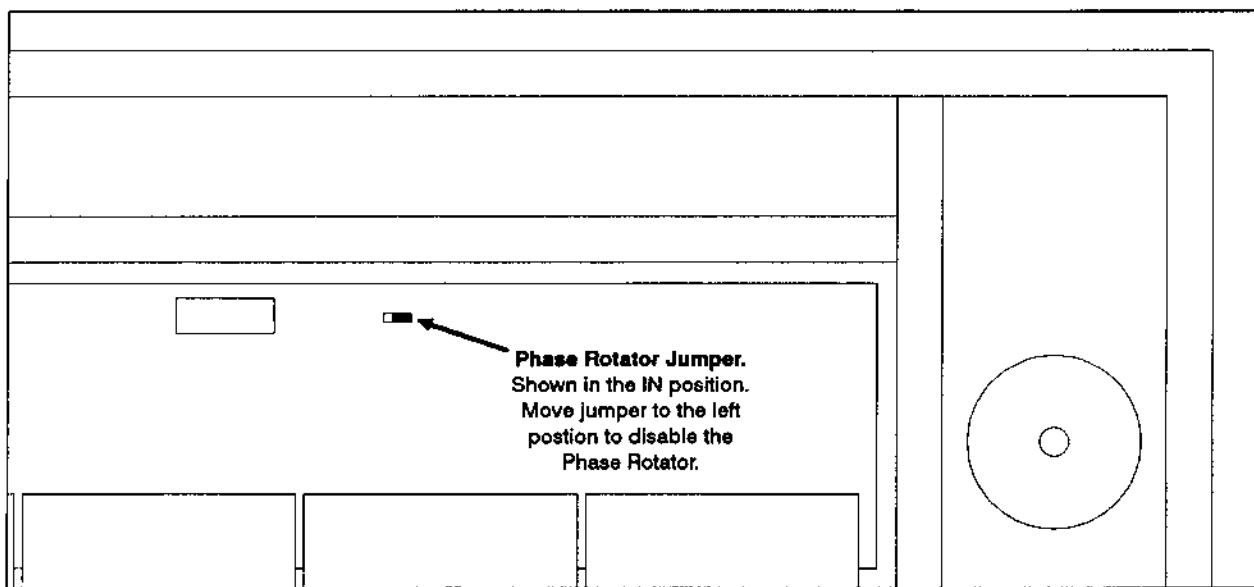

Figure 2-7  
Phase Rotator Jumper Location

### 2.7.2 USING THE PHASE ROTATOR WITH THE ORBAN OPTIMOD

The Orban Optimod 8100 contains internal phase rotators (one for each channel). When the **PRISM II FM** is used with the Optimod 8100, it is recommended that the phase rotators in the 8100 be bypassed and Phase Rotators in the **PRISM II FM** be enabled. The justification and simple procedure for bypassing the Optimod phase rotators are contained in "Removing the Phase Rotators in the 8100" on page 2-26.

## 2.8 ADJUSTMENT OF THE PRISM II FM

One of the most notable features of the **PRISM II FM** is the small amount of time required to adjust it for use. Many processors seem to have an endless number of adjustments. Setup is a long, cooperative project between the engineering and programming departments where changes are first made to this control and then that control, to see what effect each has.

The number of controls on the **PRISM II FM** has deliberately been kept to nine. Of those, two are the **INPUT** and **OUTPUT GAINS**, and four are the **MIX LEVEL** controls. Great care has been taken to insure that the controls do not interact. Each control adjusts its own assigned function and no other. This makes the setup process direct.

The external test equipment necessary for setup has also been kept to a minimum. A simple VOM, such as a Simpson 260, is all that is required.

Remove the **PRISM II FM** name plate using a 2 mm hex wrench. A small flat-blade screwdriver such as a jeweler's screwdriver or Xcelite "greenie" is necessary for the

following adjustments. Set the controls to the following approximate positions:

- INPUT GAIN ..... fully counter-clockwise
- GATE ..... 9 o'clock
- DENSITY ..... fully clockwise
- OUTPUT GAIN ..... fully counter-clockwise
- MIX LEVELS (all four) .. 12 o'clock

Apply program input at a normal level. Adjust the INPUT GAIN so that the average position of the LED bar graph in the MID band display is the fourth LED from the right end. This is the yellow LED under the letter "O" in COMPRESS. The BUFFER ACTIVE and BUFFER FULL LEDs should not be illuminated at this time.

Adjust the OUTPUT GAIN control for the desired output.

Do not be alarmed if the individual processors indicate values of compression and expansion which differ radically from each other. This is normal. With typical program material, the MID band processor will show the most compression with the bar-graph display approximately centered in the compression (yellow) range. The HIGH band will show the least, with the display midway between the quiescent position and maximum expansion. The LOW and PRESENCE bands will show intermediate compression levels, averaging near midscale. These are generalizations, however, and exact levels will depend on the instantaneous program input.

This system of staggered compression levels allows the **PRISM II FM** to implement a very effective dynamic noise reduction function. This reduces tape hiss and other undesired high-frequency noise.

As noted previously, the HIGH band processor normally operates with some degree of expansion; it will seldom compress. On music passages lacking in high frequency content, and sometimes during newscasts, it will gate off and recover to the quiescent position. Movement from the expansion range (the left half of the bar graph) to the quiescent position (center-scale on the bar graph) is from left to right. This corresponds to a decrease in gain for that band, reducing undesired noise by as much as 6 dB. Most conventional audio processors will sound differently when driven hard than when driven at a lower level. This is because the decay constant (release time) of the timing capacitor changes as the voltage on the capacitor increases. Driving the conventional processor harder increases the capacitor voltage, which speeds the discharge rate. This makes the program output "dense." For this reason, many people drive their analog-based processors far into compression on normal program level inputs.

Some announcers will also run their console output levels high, claiming that it makes the transmitted signal louder. To the extent that the higher level quickens the conventional processor's action, they are correct.

By contrast, the acoustic sound of the **PRISM II FM** does not change with changes in absolute input level. The charge and discharge rates of the timing capacitors of the **PRISM II FM's** four individual processors are a function of program character, not program level. Although the absolute control voltage will be different, the voltage recovery rate will be exactly the same when the processor is driven moderately or very

heavily. Consequently, there is absolutely no advantage in driving the unit beyond the level recommended in this section.

### **2.8.1 SETTING THE GATE CONTROL**

---

Observe the operation of the SIGNAL LEDs during normal program. They should remain steadily lit during most fully orchestrated popular music but should completely extinguish between sentences in human speech. They may also extinguish during breath pauses. The exception is the HIGH band, which may gate off much more frequently, as most program sources have less high frequency content. The above recommendations should only serve as guidelines. Unlike a computing application where the digital world is one of black and white, music and voice are moving targets. They are best described statistically, so it is not surprising that the PRISM II FM's digital control circuit response to them is also statistical. It is unlikely that one will find an unbreakable rule where the SIGNAL LED will always light for one type of event, and always extinguish for another. Rather, one will find that it usually responds in a given way.

If the SIGNAL LEDs extinguish too frequently, lower the gate threshold by turning the GATE control to the left. If they remain lit too frequently, raise the threshold by turning the control to the right. This adjustment, like the others, is very predictable and easy to control. For typical radio applications, the optimum setting of this control will usually be about nine o'clock. For television or radio talk show applications, a setting near two o'clock may be desirable to prevent "suck-up" of the higher ambient noise.

The setting of the GATE control can be quantized exactly, as the gate reference voltage appears on TP306, the BLACK test point on the motherboard. This test point is accessible through an access hole in the chassis lid on the left hand side. There are two holes — TP306 is the rightmost of the two (the other is TP307, the DENSITY reference buss).

The useful range of the GATE control for radio applications is between approximately 0.25 and 1.0 volts. A good starting point is 0.5 volts. These voltages are DC.

This control can be fine tuned later without disturbing subsequent adjustments. If, after a few days listening, you find ambient air conditioner noise in the studio and background tape hiss to be more noticeable than it should be, increase the GATE control setting. If noise is not noticeable, but subtle high end passages known to be on the source material are missing on the air, decrease the GATE control position.

### **2.8.2 SETTING THE MIX LEVELS**

---

The next item to set is the MIX LEVELS.

The MIX LEVEL controls are faders on the outputs of the four individual processors (the inputs to the processors are not individually adjustable). They control the proportions of the signal from each band which are summed together. This is called the "spectral mix."



Setting the spectral mix on a multi-band processor has typically been a time-consuming project, largely because there are few reference points to go by. A competent broadcast engineer would not begin adjusting the phaser controls of a directional antenna system without having a phase monitor, and perhaps also a field intensity meter to measure the effect of his adjustments. To properly adjust any system, you must have some type of quantizable feedback. The subjective nature of the human ear makes it anything but a laboratory instrument.

One repeatable and easily interpreted method of setting multi-band spectral mix levels is to use a Real Time Analyzer (RTA). On **PRISM II FMs** after serial number 320, the recombined output of the four bands is available on the front panel on the white test point labeled BROADBAND SAMPLE (TP205). For those stations with an RTA, this is the proper sample point.

This provides a convenient method of alignment for the station with a robust engineering budget, but it isn't practical for a small market station.

A calibration and setup circuit is included in the **PRISM II FM** which produces accurate results for the station not having access to an RTA. This circuit and its procedure use nothing more than an AC VOM. The outputs of each of the MIX LEVEL controls are available at convenient test points on the front panel. Each is buffered and short-circuit protected so that backfeeding or loading these points will not affect the output on the air. The level is such as to give a useful reading on a 2.5 VAC VOM scale with each of the MIX controls in its normal operating range.

Using the **PRISM II FM's** internal precision PINK NOISE generator and these test points, it is possible to accurately quantize the spectral mix. This is instrumental in arriving at a chosen mix, in being able to return to it should it be tampered with, and in being able to repeat a particular sound at another station.

No inference regarding relative spectral balance should be drawn from the mechanical positions of the MIX LEVEL controls. The gains of the follower amplifiers (U302A, U303A, U304A and U305A) are not equal, nor are the gains of the bandpass filters equal (U302B, U303B, U304B and U305B). As a result, matching physical positions of the MIX LEVEL control shafts does not indicate "flat" response. Judgments regarding the spectral mix should be made only by measuring the voltages appearing at the front panel test points.

When the PINK NOISE switch is turned on, it automatically removes the DENSITY control from the circuit and forces the DENSITY buss to 5 volts. It also removes the GATE control from the circuit and drops the GATE buss to 0 volts. When the PINK NOISE switch is turned off, it returns both controls to the circuit. This function is accomplished by FET switch Q101 on the CX-2 PC board.

Appendix A of this manual is a tabulation of field-proven spectral mixes. They are grouped according to the transmitting or limiting equipment used in conjunction with the **PRISM II FM**.

When used for FM broadcast, the **PRISM II FM** is designed to be used primarily in conjunction with the Gentner Lazer or the Orban 8100 or 8000 limiter/stereo generators.

In addition to providing suggested settings for the **PRISM II FM** when used with the Gentner Lazer or the Optimods, suggested setup parameters are also provided for both Optimods when using them in conjunction with the **PRISM II FM**.

Appendix A does not describe how the display should appear on an RTA or other precision instrument, as few VOMs have a flat AC voltage response across the audio frequency range. In fact, it is apparent that when using the Triplet brand meter equivalent to the Simpson 260, different results will be obtained. This is not to say that the frequency response of the Simpson meter is superior to that of the Triplet, or vice versa, or that either one of them, in fact, has flat response. The purpose of the table is simply to present a repeatable starting point for the largest possible number of engineers. The Simpson 260 is the meter used as reference for the values in the table.

Tests have shown that identical results are obtained when making these adjustments using the Potomac Instruments AA-51 Audio Analyzer. Note that the AA-51 is an AC voltmeter only. If, during this same maintenance session, it is desired to also set the GATE and DENSITY controls according to meter readings, it will be necessary to have on hand a separate meter for the DC readings.

Because of the pulsating nature of pink noise, particularly in the two lower frequency bands, an analog meter (one with a mechanical pointer) must be used for these measurements. A digital readout meter cannot be used. A digital or analog meter may be used for the DC readings on TP306 and TP307. Using a small flat-blade screwdriver, switch the PINK NOISE generator ON. Ground the black probe lead of an AC VOM or VTVM to the **PRISM II FM**. There is a black test point provided for this purpose located to the left of the "Q" LED in the LOW band section of the front panel. Grounding to the equipment rack may produce incorrect results. Insert the other probe into the green front panel test point in the HIGH band sector. Adjust the HIGH band MIX LEVEL control until the voltmeter reads as suggested in Appendix A for the equipment you are using. The audio levels in Appendix A are in dBm *not* volts. Move the probe to the PRESENCE band test point and adjust the PRESENCE band MIX LEVEL. Repeat for the two remaining bands.

The output of the PINK NOISE generator is pseudo-random and has some sizeable low frequency thumps in it. As a result, on the two lower bands, the voltmeter will not come to rest on a specific number as it did on the higher bands. Rather it will continuously swing over a small arc on the meter. Note in Appendix A that the setup numbers for each of the two lower bands represent the average reading of the meter. This can be arrived at by reading the maximum and minimum values and averaging them.

The performance and sound of one **PRISM II FM**, set to a given set of parameters, is identical to the sound of another adjusted to the same parameters. As a result, the parameters listed in Appendix A should be close to the optimum for that equipment.

There are two common exceptions:

1. Research indicates female listeners are far more sensitive to high frequencies than are men. Stations whose formats are deliberately skewed for high female listenership may choose to reduce the two higher frequency MIX LEVEL controls slightly.

2. FM stations using music sources with particularly clean high end, such as from a Compact Disk (CD) player, may find it desirable to reduce the HIGH band MIX LEVEL.

■ **CAUTION :** Care should be exercised when adjusting the spectral mix not to operate all four controls near the top of their range. The gain of the summing amplifier (U101A on the CX-2 board) is chosen to permit full utilization of the capabilities of the output stage with normal adjustment of the MIX LEVEL controls. Clipping at the summing point may result under some combinations of settings. No damage to the unit will result, but noticeable distortion can be produced.

This distortion cannot be removed by reducing the OUTPUT GAIN control as it is already present before the output stage. The output stage can produce voltage swings to approximately 9 volts either side of ground (12 volts with the surge suppression circuit defeated). If this problem is present, distinct flattop clipping will be apparent, but the amplitude of the clip may be at considerably less than 9 volts. It will be a scaled model of a clipped wave (scaled by the OUTPUT GAIN control, R104).

This problem usually occurs only after a series of empirical adjustments where first one, and then the other mix level is increased. All of the recommended mix levels in Appendix A have been tested to insure they do not clip at the summing point.

An approximate rule of thumb is to add the mix levels at the front panel test points and see if they total 20 or greater. If they do, clipping is likely and the settings should be reduced. The recommended settings for use with a stock Orban 8100 are 5,4,4, and 3 dBm for a total of 16, which is less than 20.

If you have arrived at a desired spectral mix by trial-and-error and would like to preserve that mix but find it produces clipping, the solution is simple. With the PINK NOISE generator on, measure and record the voltages found at each of the front panel test points. Then readjust the MIX controls to subtract an equal number of dB from each. Increase the OUTPUT GAIN to make up the difference in output level.

For example: Front panel voltages of 6, 7, 8, and 5 dBm are encountered at the test points. The sum of the values is 26 so clipping is likely. Reduce the settings of each control by 3 dB so the voltages are 3, 4, 5, and 2 dBm. The sum is now 14, which is less than 20. Increase the OUTPUT GAIN control by 3 dB to return the output level to its previous value.

PRISM II FMs have a front panel test point marked BROADBAND SAMPLE. This is the output of U101A. An oscilloscope with accurate vertical calibration can be used at this point to be sure that no flattopping is present. The voltage swing here should not exceed +/-13V.

There is temptation on a multiband audio processor to attempt to measure its performance at the output while sweeping the input with sine wave tones. Steady-state tones can frequently provide erroneous information for a number of reasons. Probably the most obvious source of such aberrations relates to the GATE circuit. For tones of certain

amplitudes, when the tone is in the center of one particular band, the corresponding M-102 processor card will expand to capture the signal. The other three bands will gate off. Only the active band will provide a significant output to the equipment which follows. When a tone of the same amplitude is injected at the crossover frequency between two bands, the M-102 processor cards for both bands will expand to capture the signal. Unlike the previous case where only one band provided significant output, now both M-102s will provide significant output, making the overall output up to 3 dB higher than when the tone was centered in one of the bandpass filters. This phenomenon, known as "crossover buildup," is not specific to the **PRISM II FM**, but is typical of all multi-band processors.

It is best to make adjustments and draw information only when the **PRISM II FM** is fed either pink noise or program material. Attempting to draw conclusions from sine wave signal sources will seldom produce meaningful information and should be avoided.

If it appears that settings other than those appearing in Appendix A are most suited for the station, a simple familiarization with the frequencies in each band will often make adjustment much easier. Each of us usually has a general idea of what the sound of a certain frequency is, when expressed to us in Hertz. However, under program conditions, we may be less able to accurately judge which band a certain group of frequencies falls into, even if we know the frequency limits of the band.

One way to make a direct correlation in our minds between a particular aural sound and the band it falls into is to listen to the outputs of the four individual bands. This is easily accomplished at the four front panel test points (TP201, TP202, TP203, and TP204). Connect an amplifier to drive a speaker or pair of headphones. The gain should be such that sufficient sound level can be produced from a 1 volt AC source. Connect a test probe to the input of the amplifier and insert it into one of the front panel test points. The sound will be very unnatural because it contains only one band of frequencies. Make a mental note of what frequencies are in that band. Move the probe to the next band and again make a mental note. Repeat the process for the remaining two bands.

Monitor the overall on-air sound with typical program material. When attempting to boost or attenuate certain frequency bands to achieve the desired overall air sound, it will be obvious which **MIX LEVEL** control affects the desired band of frequencies.

### **2.8.3 ESTABLISHING THE L-R CHANNEL NULL**

---

A monaural source fed to any FM stereo system should produce no modulation of the difference (L-R) subcarrier. This requires matching both the phase and amplitude of the signals in the left and right channels. In a multi-band processor, this means matching the spectral mix levels of the left and right channel units to each other to achieve the null. One method to null the L-R subcarrier is to set the front panel test point sample voltages to equal levels as observed on the Simpson 260 or Potomac Instruments AA-51. This will produce a channel-to-channel balance closer than can be detected by the human ear. However, if you measure stereo performance of the station on an oscilloscope lissajous figure (X-Y display format), a better null is desirable.

Frequently the oscilloscope is used to monitor phase alignment of stereo sources, particularly cartridge and reel-to-reel tapes. A spreading of the diagonal scope trace on a source which should be monaural indicates a poorly phased source, which will cause loss of high-frequency response.

The lissajous pattern will respond to mismatches in both phase and amplitude. Small phase mismatches will degrade the station's fidelity significantly; small amplitude mismatches will affect it only slightly. However, it is nearly impossible to tell one from the other on the lissajous pattern. While a small amplitude mismatch will not significantly affect the station's quality, it will hinder detection of phase mismatches which will affect the station's quality.

As a result, a better null than can be produced by the above method is desirable for the station using a lissajous monitor. Unit-to-unit tracking of the **PRISM II FM**'s bandpass filters and dynamic characteristics is excellent, allowing a dynamic, broadband null of the difference channel of greater than 30 dB (referenced to left-channel-only modulation at 100%).

Some stereo enhancement devices have a circuit which inhibits the enhance function during monaural source material. If the L-R null at the output of the **PRISM II FM** is not of high quality, the stereo enhancer may not recognize the monaural source material and the inhibit circuit may not perform properly.

Certain techniques simplify achieving the L-R null. The preferred method requires an external PINK NOISE generator.

Connect the PINK NOISE generator to the paralleled inputs of both **PRISM II FM**s. (One cannot simply turn on both internal PINK NOISE generators. For this procedure, it is necessary for the units to both operate on the same source material. While the two internal PINK NOISE generators will have the same spectral output, they are not synchronized in time.) Adjust the INPUT GAIN controls on both units so that the MID band bar graphs read about  $\frac{3}{4}$  scale. Connect a 10K resistor to the "+" output terminal of one **PRISM II FM**. Connect a second 10K resistor to the "-" output terminal of the other **PRISM II FM**. Twist or solder the two loose ends together. A high-impedance source of L-R signal occurs at this junction. You can look at it with any of three measurement devices: real time analyzer, oscilloscope, or voltmeter.

Regardless of the selection of measurement devices, the object is the same: to minimize the signal present at this junction while the two **PRISM II FM**s are fed the same pink noise signal. One unit should be specified as the reference unit and the other unit matched to it. If you tune first one **PRISM II FM** and then the other, it is possible to creep away from the original desired settings.

If using the real time analyzer, it is a simple matter to tell which frequency band(s) the residual signal is in, and therefore, which MIX LEVEL controls should be adjusted to improve the null. The oscilloscope also displays frequency information in somewhat less direct form. Using the oscilloscope, you can judge the relative frequency of the residual from its wavelength on the display tube. Long, loose lines which bounce every few seconds indicate a residual in the LOW band. Tight waveforms that appear like grass on the scope tube indicate a residual signal in the HIGH band.

To determine which waveshape will be displayed on the scope tube by each band, momentarily unbalance the null. Turn the control for a given band and channel a significant distance from the null. Then turn the control back through the null and well past it in the other direction. Return the control to the null and then unbalance the next band. Repeat this procedure for the other two bands until your eye can recognize the characteristic wavelengths of the frequencies contained in each band. Then null each of the four bands. Repeat the procedure until the null is at least 30 dB. It may be necessary to go through each control several times to reach this level.

If neither a real time analyzer nor an oscilloscope is available, a simple audio voltmeter can be used. However, the voltmeter will display only amplitude information. Unlike the other two devices, it does not display frequency information.

Turn the LOW band MIX LEVEL control for the best null on the audio meter. Then repeat for the other three bands. Return to the LOW band control and repeat the sequence until a null of 30 dB is achieved.

An L-R imbalance is primarily caused by the band furthest out of balance which will mask the other bands with less imbalance. Only adjustment of the band which is most imbalanced will have any real effect. Once this control has been adjusted so that its contribution to the total imbalance is less than that of another band, it will then be necessary to determine which band is now most out of balance.

Without frequency information, this can be ascertained only by trial and error. For this reason, adjusting the L-R null using only an audio voltmeter is a recursive procedure. While the null produced using only an audio voltmeter can be equal in quality to that produced by the other instruments, it will require more patience.

If an external pink noise generator is not available, acceptable results can generally be obtained using the real time analyzer or oscilloscope methods and monaural program material as source. (It will not work with the audio voltmeter method because of the wide swings in level.) As mentioned previously, tones are not an acceptable signal source when adjusting the L-R null. Only full spectrum signal sources are useful for this procedure. Some consoles have a "mono" switch which straps the left and right channel outputs together. Otherwise, patch one channel of the console to a patch mult and feed both **PRISM II FMs** from the mult output. Adjust the **PRISM II FM MIX LEVEL** controls in the recursive manner described above for the best null. This will require full spectrum music input to work properly. Too much level variation exists in voice to produce meaningful results. If this procedure is performed while on the air and a spot cluster of news block comes up, it may be better to wait for a return to music before continuing.

After the null is achieved at the output of the **PRISM II FMs**, the two 10K resistors should be removed from the barrier strips. The RF protection filters make the **PRISM II FM** dynamic output source impedance some small finite value greater than zero. Accordingly, some minor but measurable crosstalk between channels will result if the resistors are left in. Do not yet configure the input source for stereo.

With the spectral mixes of the two **PRISM II FMs** matched, producing the proper on-air L-R null requires only balancing the left and right channel overall gains. This can be

done using one of the **PRISM II FM OUTPUT GAIN** controls, or one of the **INPUT** controls of the limiter device which follows the PRISMs.

Ideally, the L-R subchannel should be read off-air on the station's modulation monitor. This will test the system closed-loop, including any anomalies which may also be present in the exciter, transmitter, and antenna system. If this is not convenient, a reasonable null can be achieved by turning the limiter metering switch to the L-R position. Slowly vary the input gain of one channel of the limiter. Some limiters switch 20 dB of additional gain into the meter circuit in the L-R position to allow locating the null more precisely. Remember to reset the console to stereo or reconfigure the patch bay to stereo operation when the procedure is complete.

During the early setup procedure, when you intend to make further adjustments after listening tests, it is often desirable to have a reasonable balance of channels. However, because the **MIX LEVELS** are only temporary, it is not efficient to spend the time to adjust for a perfect channel balance. When using the Optimod 8100, a reasonable balance can be obtained by adjusting one of the Optimod **INPUT GAIN** controls for equal flashing of the two front panel **HF LIMIT** LEDs. Even with stereo program material, this is a reasonably good indication of channel balance. Minor variations can usually be averaged out with the eye to produce an acceptable null.

#### **2.8.4 SETTING THE DENSITY CONTROL FOR RADIO APPLICATIONS**

As was noted earlier, the **DENSITY** control establishes the character or aggressiveness of the processing. While the intelligence of each processor is unchanged, varying the **DENSITY** control changes the number of actions which it will choose to take in a given time period. At lower settings it provides dynamic noise reduction, loudness control, and a gentle average level control. These settings are very adaptable to TV and CATV audio channels, where high average modulation levels are neither necessary nor desirable. Rotating this control clockwise provides all of the above functions, plus a denser average modulation level.

The **DENSITY** reference buss, like the **GATE** reference buss, is available on a test point and can be quantized exactly. The normal setting of the **DENSITY** control for television and CATV applications will produce approximately 2.5 DC volts on TP307, the green test point on the motherboard. As also described earlier, this test point is accessible through an access hole in the chassis lid.

The normal setting for radio application (fully clockwise) will produce approximately 4.25 volts at this test point. The exception is satellite up-link program control for radio. Where it is expected that the program will be processed again before it reaches its final destination, a lesser setting may be desirable.

While proper adjustment of this control is essential for proper program handling, its effects are subtle. It is not the primary control by which the broadcast user will determine his loudness/quality tradeoff. Rather, that function will be determined almost entirely by the amount of **VCA** action in the limiter which follows the **PRISM II FM**. This action is adjusted with the **INPUT ATTENUATOR** control on the Orban Optimod.

The proper adjustment for the INPUT ATTENUATOR controls on the Optimod is discussed later in this manual in "Suggested Adjustment of the Orban 8100" on page 2-24 and "Operation with the Orban 8000" on page 2-27.

### **2.8.5 SETTING THE DENSITY CONTROL FOR TELEVISION APPLICATIONS**

Television audio, because of its diverse nature, is perhaps the most difficult audio to handle. It contains widely varying levels, long pauses, and no background orchestration to forewarn the processor of what it will do next. For that reason, a set of processor adjustments desirable for one program might be intolerable for another. Many television stations process the audio very little as a result.

Radio usually processes for maximum loudness, television processes for uniform loudness, and the two are nothing alike. Radio broadcasters are granted a transmission channel of a given size, and most process the audio to fill the channel. This insures that the signal will penetrate every geographic area the channel size will allow.

Television audio, on the other hand, is not the limiting factor which determines the coverage area in that medium — the visual signal is. Commission rules permit an aural carrier power of no less than 10 but no more than 20 percent of the peak visual power. This essentially guarantees that the audio signal will go everywhere the visual signal does. Frequently, the aural signal will go substantially further. Louder or more dense audio will not increase the coverage area. Overprocessed television audio will simply sound unnatural and irritate listeners.

The goals for television audio processing are to maintain the peak modulation within the FCC's 100% limit, and to produce a consistent product. The FCC and the NAB have both, from time to time, convened a number of panels looking into the varying loudness levels typically found in television broadcasts. Commercials which have a higher apparent loudness have been a recurring problem. Part of the problem is the number and differing types of television program sources. A commercial on video cassette has a magnetic sound track. The movie which follows it may have an optical sound track. The following live local newscast may originate several floors away. In that newscast, there may be a live, on-location, ENG feed. Each source is usually very different from the last.

Even among similar sources, there is considerable individualism. Of two video cassettes, one may have been recorded locally on the same machine it will play on. The other may have been recorded a continent away on a different machine. In an effort to produce a consistent product from these varied sources, television broadcasters have sought to control loudness through processing, being conscious that overprocessing is equally irritating in a different way.

The **PRISM II FM** is adept at creating a consistent product without producing processing artifacts. A **DENSITY** control setting of 10 o'clock is a good starting position.

If, after a period of listening, the program appears to lack uniformity, turn the **DENSITY** control to the right. If it seems too uniform, turn the control to the left. This adjustment, like the **GATE**, is very predictable and easy to control.



The key to final adjustment of the **PRISM II FM** in television applications is to listen to a number of different source programs. One particularly difficult test is the popular "Road Runner" cartoon show, which is characterized by extended pauses followed by explosive percussion.

#### **2.8.6 SPECTRAL MIX ADJUSTMENT WITH THE ORBAN 8100**

---

Final adjustment of the **MIX LEVEL** controls should be done in two parts when the **PRISM II FM** is used in conjunction with the Orban 8100. The 8100 is a complex and sophisticated device. It has the ability to change tonal balance in an effort to find the optimum compromise between loudness and fidelity. When doing on-air listening adjustment, it is possible to make a **MIX LEVEL** adjustment on the **PRISM II FM** which is counteracted by a dynamic response in the 8100.

For example: Let's say you have just dialed in more highs. The 8100, in an effort to maintain a uniform sound, will remove them. The net effect on the air is no change. To prevent this problem, establish a high quality monitoring ability at the input of the 8100. Set the **MIX LEVEL** controls for the desired tonal balance monitored at this point. Then compare the on-air sound of the 8100 to its input. If they are not the same, adjust the 8100.

Additionally, the use of a composite clipper will have some effect on spectral coloration and balance. The most desirable setting of the **PRISM II FM MIX LEVEL** controls when using the 8100 in conjunction with a composite clipper may be slightly different from what they would be without a composite clipper. Composite clippers are discussed in greater detail in "Composite Clippers" on page 2-32.

#### **2.8.7 THE GENTNER REPLACEMENT CARD FIVE (RCF-1)**

---

For FM applications, Gentner manufactures a plug-in replacement for Card #5 of the Optimod 8100 which more perfectly matches the characteristics of the Optimod and the **PRISM II FM**. This card installs in three minutes using only a screwdriver and an allen wrench. No soldering or other modifications are required. Installing the RCF-1 does not preclude also installing the Orban "Card Zero."

Adding a pair of **PRISM II FMs** in the program line before the Optimod 8100 will produce significant benefits. As such, the RCF-1 is not a necessary addition for the **PRISM II FM** to function properly, however, the RCF-1 does add to the improvement. The RCF-1 can produce from 1.5 to 2 dB more loudness and has a variable **BASS BOOST** control.

The time constants of the RCF-1 have been tuned to assume the Optimod input has been preprocessed by two **PRISM II FMs**, thus eliminating radical variations in input level. The RCF-1 should not be installed in a "barefoot" Optimod. The **PRISM II FMs** may be used without the RCF-1, but the RCF-1 cannot be used without the **PRISM II FMs**.

A complete description of the RCF-1 is in Section 4, RCF-1 Replacement Card Five.

---

## 2.9 SUGGESTED ADJUSTMENT OF THE ORBAN 8100 (FM APPLICATIONS)

---

The following settings of the Orban 8100 are recommended for use in conjunction with the **PRISM II FM** and when operating with the original Orban Card Five. For suggested adjustment using the Gentner RCF-1 Replacement Card Five, see Section 4, RCF-1 Replacement Card Five.

### 2.9.1 RECOMMENDED SETTINGS FOR THE STOCK OPTIMOD 8100

---

- CLIPPING ..... 0 (slightly past 12 o'clock – see text)
- HF LIMITING ..... 5
- RELEASE TIME ..... 0 to 3
- BASS COUPLING ..... 0 to 4
- GATE ..... 0 (fully CCW)
- INPUT ATTENUATORS .. (see text)

Some very early 8100s had a different legend silk-screened on the CLIPPING control than the one referred to above. The present legend is in dB of clipping and has both positive and negative values. Note that the 0 point is slightly past the 12 o'clock position. The earlier legend was labeled simply from 0 to 10. For those users with the older legend, the recommended setting of the CLIPPING control is 6.

Be aware that the above recommended settings for the Optimod 8100 are applicable only when the unit is used in conjunction with two **PRISM II FMs**. These settings, if used on a stand-alone 8100, will produce a very undesirable sound.

No blanket statement can be made as to what the physical position of the input attenuators should be, because the audio input level presented to the Optimod will be different at different stations. Rather, these controls should be adjusted to produce the proper deflection of the TOTAL meter on the Optimod. This is the leftmost, edgewise meter on the Optimod face.

As discussed previously, the setting of these two controls, more than any others, will determine the loudness/quality tradeoff of the entire system. Greater amounts of gain reduction will produce increased perceived loudness and reduced quality.

Naturally, the TOTAL meter will fluctuate with program material. The references below give the range through which the meter should swing. It is important that the RELEASE TIME control be set between 0 and 3, as recommended above, for these readings to be meaningful. The following are only guidelines.

**Light processing** can be characterized as the TOTAL meter hanging at 5 dB of gain reduction and peaking to 9 dB. This is appropriate for the broadcaster who has a format unique to his market or who feels that additional quality far outweighs a small reduction in perceived loudness.

**Moderate processing** can be characterized as the TOTAL meter hanging at 8 dB of gain reduction and peaking to 12 dB. This is appropriate for the large majority of

broadcasters who must be competitive but who are concerned with quarter hour maintenance.

**Robust processing** can be characterized as the TOTAL meter hanging at 11 dB of gain reduction and peaking to 15 dB. These settings are appropriate for a station which is concerned primarily with listener cumes.

**NOTE:** Do not use the Orban XT chassis in conjunction with a PRISM II FM because they may fight each other.

### **2.9.2 RECOMMENDED SETTINGS OF THE GATE THRESHOLD, BASS COUPLING, AND RELEASE TIME CONTROLS FOR FM APPLICATIONS**

---

The following material pertains only to Optimod 8100s utilizing the stock Orban card #5. For adjustment of 8100s equipped with the RCF-1 Replacement Card #5, see Section 4, RCF-1 Replacement Card Five.

Every on-air processing system should include a gate function to prevent "swish-up" of noise during periods of reduced program level. However, there is no additional benefit in having two gates in the same chain. The two gate circuits may, under certain circumstances, interact, causing undesirable effects. The GATE THRESHOLD control on the 8100 should be set fully counterclockwise.

Reducing the setting of the BASS COUPLING control increases the low "bone-jarring" bass and general excitement of the air product. Most program material is handled satisfactorily with this control fully counterclockwise (0 setting). However, about one record in four will be handled in an unnatural manner. This phenomenon is not rooted in distortion or sound coloration; rather, the music will seem awkward and syncopated. Four appears to be the lowest practical setting of this control when used with **PRISM II FMs**.

Relative to the recommended setting for the 8100, the largest number of questions received on earlier revisions of this manual pertained to the setting of the RELEASE TIME. Typically, the question was asked, "Do you think it advisable to run the Optimod that fast?" Much of the circuitry of the 8100 is proprietary and epoxy encapsulated, and therefore, it is not known exactly how this control functions. However, it is not clear that any time constants in the 8100 are actually lengthened or shortened by it. Rather, one explanation is that the 8100 contains a limiter with a predetermined time constant and a compressor with a predetermined time constant. The RELEASE TIME control determines what proportion of the mechanisms to use. When this control is turned fully clockwise, the 8100 implements a large proportion of compression and a small proportion of limiting. When turned fully counterclockwise, the converse is true. The apparent effect to the user is that turning the control further clockwise makes the front panel meters move slower. This explanation receives circumstantial support from the fact that the fully counterclockwise position on this control on the earlier Optimod 8000 bore the supplemental label, "limit only."

As this is written without knowledge of what is contained in the 8100's encapsulated modules, the absolute accuracy of this model is not known. The model does appear sufficiently accurate for the purposes of this section.

The purpose in setting this control fully counterclockwise is to obtain the minimum gain reduction in the 8100's analog based compressor while utilizing that amount of gain reduction in the 8100's limiter to achieve the desired loudness.

Ideally, the 8100's compressor would exercise only sufficient gain reduction to compensate for the up to 3 dB of recombination error present in the output of any multi-band processor. This is done with the RELEASE TIME control set fully counterclockwise.

The effect of turning the RELEASE TIME control clockwise is to reduce the amount of limiting and increase the amount of compression. However, the compression function is accomplished in the **PRISM II FM's** digital processors. Further compression is unnecessary.

If the on-air product appears more active or strident than is appropriate for the format, a method of reducing this activity, preferable to increasing the release time, is simply to reduce the input gain of the Optimod. This will reduce the amount of limiting, but without adding to the amount of compression used.

If adequate loudness cannot be obtained from the stock Orban card #5 without unacceptable program harshness, contact Gentner for information on obtaining the RCF-1 Replacement Card Five.

### **2.9.3 REMOVING THE PHASE ROTATORS IN THE 8100 (FM APPLICATIONS)**

Each channel of the Optimod 8100 input circuit contains a phase rotator. Its purpose is to remove any asymmetry present in the input signal. It is recommended that the 8100 rotators be bypassed and that the Phase Rotator in the **PRISM II FM** be used. See "Use of the Phase Rotator" on page 2-11 for more information on the Phase Rotator. **PRISM II FMs** are shipped from the factory with the Phase Rotator enabled.

Phase rotators work by changing the phase relationships between critical odd-order harmonics in the lower voice frequencies. The human ear is not phase sensitive and, if the rotator is properly designed, a listener cannot tell the output wave from the input wave. However, the peak-to-average ratio of a signal after phase rotation is very different than before rotation. While the human ear cannot distinguish between the two, an audio processor will react very differently to the signal after rotation than it would to the same signal before rotation.

Optimum performance requires that the **PRISM II FMs** and the Optimod work in harmony. When using the rotators in the Optimod, rotation takes place after the variable gain stages in the **PRISM II FM** but before the variable gain stages in the Optimod. The **PRISM II FMs** and the Optimod are actually operating on two very different signals. An important rule for the use of phase rotators is: *A phase rotator, if used, should precede every variable gain stage in the audio system.*

This is, in fact, the location of the Orban phase rotators if the Optimod is used alone. Bypassing the Orban rotators and using the Phase Rotators in the PRISM II FM places the rotators first in line in the new system. The Phase Rotators also accomplish their task with less total phase shift. The Orban rotators utilize 540 degrees of rotation to accomplish their purpose, while the PRISM II FMs use only 360 degrees of rotation.

Refer to the 8100 Operating Manual, schematic drawing #60034, "Schematic, PCB, Left & Right Compressors, Card #3 & #4" on page J-5. Locate test point TP1 at the top center of the drawing. To the left of that, locate connection "W" which feeds the panel meter. This is the feed-through at the end of finger "W" of the card edge connector.

To bypass the phase rotators, remove IC303, R359, IC403, and R459. (IC403 is in the same position as IC303, but on Card 4. A similar condition holds for R359 and R459.) Connect a small jumper wire from TP1 to card finger "W" on the edge of Card 3 and Card 4. Each of these connections passes through a plated-through hole, making placement of the jumper a simple matter. Solder the jumper into the two appropriate holes. If it is desired to return the 8100 to original condition at some future date, the jumpers can be removed and the chips replaced, leaving no permanent marks.

Notice that this change also removes the 30 Hz highpass filter from the circuit. The highpass function is already provided in the PRISM II FM and a second is unnecessary. You should not, however, attempt to disable IC302B and IC402B. While they are no longer in the program flow, they continue to feed the GATE control sample at the "V" connection. This signal must continue to be present for the 8100 to operate properly.

---

## 2.10 OPERATION WITH THE ORBAN 8000 (FM APPLICATIONS)

---

One of the most powerful yet unfatiguing FM sounds possible today can be produced using the Orban 8000 limiter/stereo generator and two PRISM II FMs. Because of the near absence of discretionary adjustments on the 8000, setup is simple, quick, and will produce a quality product. The Optimod 8100 will be required by the competitive conditions in most major markets. However, the 8000 is very satisfactory for many smaller markets and also for backup service in major markets.

After setting all other controls on the PRISM II FMs, set the outputs for equal level suitable to drive the telephone lines (STLs). Set the RELEASE TIME control on the 8000 fully counterclockwise (limit only). Using music as a program source and with the METER switch in the G/R position, adjust the 8000's input attenuators for 3 dB of broadband gain reduction on frequent peaks. On infrequent peaks, the meter should indicate 5 dB of gain reduction.

Extensive field tests have shown that best results are obtained when the 8000 inputs are conscientiously maintained in this range. Less than 3 dB of gain reduction does not permit the 8000 sufficient range of control to maintain maximum modulation. Program density and loudness will be lost. Greater than 3 dB of gain reduction on frequent peaks will cause excessive action of the 8000's HFL (high frequency limiter). This will unnecessarily roll off high frequency response, noticeably dulling the program.

A significant improvement in program quality and clarity is possible by replacing some of the integrated circuits in the 8000. The Texas Instruments BIFET series of operational amplifiers, which were not available when the 8000 was designed, are superior in many ways to those used in the original 8000 design. Later versions of the 8000 used the newer operational amplifiers in some locations.

These improvements can be completed in an afternoon. We recommend them for all Orban 8000s to be used in conjunction with the PRISM II FM.

**2.10.1 RECHIPPING THE ORBAN 8000 (FM APPLICATIONS)**

---

■ NOTICE

THE FOLLOWING CHANGES ARE NOT ENDORSED BY THE EQUIPMENT'S MANUFACTURER AND MAY AFFECT YOUR ABILITY TO HAVE FACTORY WORK PERFORMED ON YOUR UNIT. THE FOLLOWING CHANGES HAVE BEEN THOROUGHLY RESEARCHED AND TESTED. NUMEROUS ENGINEERS HAVE IMPLEMENTED THEM WITH EQUALLY SUCCESSFUL RESULTS. HOWEVER, GENTNER ELECTRONICS CORPORATION SHALL IN NO MANNER BE LIABLE FOR DAMAGES, DIRECT, CONSEQUENTIAL, OR OTHERWISE, ARISING FROM USE OF THE FOLLOWING INFORMATION, WHETHER DUE TO MISUSE OR NEGLIGENCE ON THE PART OF EITHER PARTY.

Several schemes for upgrading the integrated circuits in the Orban 8000 have been published or circulated in the past few years. The following are informally known in many areas as the "Chris Hood modifications," named after the Pittsburgh based designer of the STA-MAX, who developed them. One rechip upgrade is available by returning your 8000 to Orban. However, some 709 op-amps are left in the unit. The following procedure is more complete than the one performed if you return your 8000 to the factory.

Parts required are:

- 8 .....TL071CP low-noise operational amplifiers
- 2 .....TL072CP dual low-noise operational amplifiers
- 2 .....capacitors, 0.1 uF, 25WVDC, mylar
- 2 .....capacitors, 47 uF, 16WVDC, electrolytic (see text)

The following table lists the device type of the amplifiers presently on the limiter board, and those of the devices that will replace them.

<u>CIRCUIT PART #</u>	<u>OLD DEVICE TYPE #</u>	<u>NEW DEVICE TYPE #</u>
IC201	301	TL071CP
IC202	301	TL071CP
IC203*	1556	TL071CP
IC204*	1556	TL071CP
IC205	709	TL071CP
IC206	709	TL071CP

IC209	4558	TL072CP
IC210	4558	TL072CP
IC211	709	TL071CP
IC212	709	TL071CP

- \* IC 203 and IC 204 need not be replaced if the highpass filters have been bypassed (see page III-2 in the 8000 Operating Manual).

Refer to the diagram entitled "Limiter Board Alignment Points" in the rear of the 8000 Operating Manual to locate the above devices. All of the replacement devices are plastic 8-pin DIP packages. It is possible that some of the original devices to be replaced are metal cans with their leads formed to fit a standard 8-pin DIP pattern. Remove these as you would the other devices. Orient the replacement device using the index notch shown on the above mentioned diagram.

Removing components soldered directly to double-sided circuit boards can be difficult without the proper tools and knowledge. Only a few 8000s were manufactured with sockets for all ICs. If yours was not, before attempting to remove components from the circuit board, familiarize yourself with the section entitled "Replacement of Components in Printed Circuit Boards" on page V-4 of the 8000 Operating Manual.

Proceed as follows:

- Using a small pair of diagonal cutters, remove pins 1, 5, and 8 from each of the 8 TL071CPs. (Alternatively, you could simply bend them up so they will not make contact when inserted in the circuit.)
- Replace IC209 and IC210 with the two TL072CPs.
- Using the remaining 8 ICs, replace IC201, IC202, IC203, IC204, IC205, IC206, IC211, and IC212.
- Locate R263. Disconnect either end from the circuit board. Connect one of the mylar capacitors between the now vacant connection on the circuit board and the loose end of the resistor. There should now be a series RC network where the resistor was.
- Locate R264. Disconnect either end from the circuit board and connect the other mylar capacitor as above.

These resistors sample the audio signal for the HFL stages. It is possible for a strong bass note, such as a bass drum, to "punch a hole" in the high-frequency band by falsely activating the HFLs. Decoupling the sample to the HFLs with the capacitors reduces this phenomenon.

- Replace C605 and C606 with new units of the same value.

C605 and C606 are electrically in the power supply, but are mounted on the limiter board just to the left of the two large heat sinks. While not specifically contained in the

audio section, these capacitors can have a marked effect on audio performance. Electrolytic capacitors sometimes deteriorate with age, particularly in the presence of higher ambient heat. Usually this is evidenced by a decrease in value as the electrolytic paste dries and becomes ineffective. Below a certain value, the capacitor no longer has sufficient filtering capacity to accomplish the task for which it was intended.

These particular capacitors, if their value changes significantly, can cause the power supply to oscillate. If this happens, a number of symptoms can appear, none of which would immediately indicate the underlying problem was in the power supply.

In a number of 8000s where the above rechipping procedure was performed, this power supply oscillation was observed. Replacing C605 and C606 with new units of the same type cured the oscillation.

### **2.10.2 EVALUATION METHODS WHEN USING THE PRISM II FM IN CONJUNCTION WITH THE OPTIMOD 8100 OR THE OPTIMOD 8000 (FM APPLICATIONS)**

---

One logical method to determine the benefit of equipment (what engineers call the "delta function" and what business managers call the "marginal benefit") is to evaluate the system with the equipment installed in and then out of the circuit.

There are two legitimate methods for evaluation, and another method which, although it appears to be valid, will produce erroneous results. The method to be avoided is to connect the **PRISM II FMs** and the Optimod as a system, and to then patch the **PRISM II FMs** in and out of the circuit. In a stereo system, this would involve simultaneously inserting and then removing two patch cord plugs with each hand.

The impressions of such an A-B comparison are generally misleading. The fallacy in this comparison has to do with the fact that the human ear has a short term memory of less than a second. The time constants of the Optimod are on the order of several seconds. From the time the patches are removed or inserted to the time that the Optimod time constants have adjusted to the new input conditions several seconds will elapse. The adaptive circuits in the Optimod will "feather the edges" of any abrupt changes, good or bad, making them less noticeable. Another reason this method is not valid is the setting of the Optimod controls. As stated earlier, the control settings recommended for use on the Optimod, in conjunction with **PRISM II FMs**, are not appropriate for use with the 8100 alone.

Two comparison methods are valid. The most desirable one is to have two identical Optimods configured in two separate systems. The first system should include an Optimod, adjusted for normal operation, sourced directly from the audio console outputs. The second system would feed the audio console outputs to the **PRISM II FMs**. Their outputs would be fed to the second Optimod, which is adjusted as described earlier in this manual.

The BNC outputs of the two Optimods would then be fed to a coaxial switch or relay, which would select between the two. In this configuration, neither Optimod input is changed as one switches from monitoring one system to the other. There is no "settling



time" required for the Optimod time constants to stabilize, and the differences in performance heard are valid the instant the switch is changed. This is an ideal situation; however, many stations do not have the luxury of having two identical Optimods.

The second valid method of evaluation is to use the competition as a reference point. Using this method, the Optimod is adjusted for its maximum performance while operating alone in the program chain. Several station personnel should compare the on-air signal to that of at least two other stations with similar music. They should make specific reference notes comparing relative loudness, spectral balance, clarity, and any other subjective quality which appears relevant.

It is important to use several different listening environments to gather this information. At a minimum, they should include a handheld portable radio with a small speaker, a high quality component system, and a car radio. Data from several additional car radios may be helpful.

Much of this first half of the evaluation may already be completed as station personnel in their daily market monitoring are usually familiar with how the sound compares to that of other stations.

The **PRISM II FMs** are then installed in the program line between the console and the Optimod. They should be adjusted for proper operation and the Optimod controls reset to appropriate settings. The same station personnel again compare the on-air sound with that of the same reference stations. The improvement between the original comparison to the competition and the second comparison is the benefit contributed by the **PRISM II FMs**.

There is a very small chance that one of the reference stations may make a change in its processing system during the course of your tests. In going from part one of this test to part two, if your on-air sound appears to have gained ground compared to one station and lost ground with reference to another, one of the reference stations has changed, and the tests should be repeated.

This method of using other stations as reference points for comparison does not produce results as quickly as the two-Optimod method (several hours vs. several minutes); however, the results are equally valid. In fact, as the comparison between your on-air sound and that of the competition is what listeners will actually be witnessing, the results of this test may actually be more relevant.

---

## 2.11 BYPASS MODE OPERATION

---

The bandpass filters and the M-102 processor cards are removed from the circuit when the **BYPASS** switch is in the **ON** position. This permits the **PRISM II FM** to do two functions simultaneously: adjust the spectral **MIX LEVEL** controls under pink noise conditions while maintaining the normal program flow from the studio to the limiting device which follows the **PRISM II FM**.

### **2.11.1 ADJUSTING THE GAIN OF THE BYPASS MODE**

---

The gain of the BYPASS function is variable, allowing the user to adjust the BYPASS output level to be equal in level (but not in density) to the normal output level. This gain is controlled by R115. This control is located behind a small, unlabeled hole, located directly above the left-threaded mounting for the escutcheon cover plate. Due to physical constraints, this control is recessed slightly more than an inch, so that it is not on an even plane with the rest of the front panel controls. Use a thin flat-bladed screwdriver to access this control, such as an Xcelite "Greenie." While the control is not easily visible, a few seconds of experimentation will usually allow the user to seat the screwdriver in the adjustment slot. This control is a multi-turn potentiometer.

When in the BYPASS mode, only the INPUT GAIN control and R115 will have any effect on the output signal. The OUTPUT GAIN control is out of the circuit.

The phase sense of the PRISM II FM is reversed when in the BYPASS mode. In stereo use, both BYPASS switches must be in the same position, otherwise an out-of-phase condition will exist on the air.

---

## **2.12 USE WITH FM EQUIPMENT**

---

### **2.12.1 EXCITERS**

---

Be aware that using audio processors with single speed AFC exciters can cause a problem that sounds like multipath.

Very few FM users have experienced difficulties with their exciters when installing the PRISM II FM. In most cases, the PRISM II FMs were part of a general audio improvement program and were installed in conjunction with a composite clipper. While all modern FM exciters employ a two-speed AFC loop, there are still some in use which have only a single-speed loop. When used with heavily processed audio, these exciters are sometimes unable to distinguish between a low bass note and a low-frequency AFC correction voltage.

A sudden bass note may unsettle the AFC loop, causing a tearing sound on the air identical to that produced by multipath reception. In the case of multipath reception, the phase-locked-loop (PLL) in the receiver's detector is on the verge of unlocking. In this instance, it is the PLL in the exciter AFC which is on the verge of unlocking. The only remedy short of changing the AFC circuit is to reduce the degree of processing.

### **2.12.2 COMPOSITE CLIPPERS**

---

The composite clipper is an additional piece of audio processing equipment which is common in some markets. The composite clipper serves as an absolute final "brick wall" modulation limiting device going into the FM exciter. It has two uses which, while easy to lump together, are actually very different:

1. Compensate for "bounce" in composite STLs
2. Provide a small but noticeable increase in loudness of the on-air signal

Four factors should enter into the decision whether to employ composite clipping or not:

1. Whether the station uses a composite STL
2. Whether the station operates an SCA channel
3. Station format
4. Degree of competition for loudness among other stations in the market

All composite STLs exhibit "bounce." That is to say, three consecutive peaks of 100%, 100%, and 100% delivered to the STL transmitter may be returned as 95%, 105%, and 100% at the output terminals of the STL receiver. The ratio of peak-to-average modulation levels is not as consistent at the output of an STL system as it is at the input. This can result in a small loss of modulation level.

This is not a criticism of the design of any one, or all, composite STLs. Rather, it is simply the physical consequence of attempting to pass a clipped waveform through a program channel with finite bandwidth. Long microwave paths appear to be affected more than short paths.

The composite clipper, when installed between the STL receiver and the FM exciter, can restore the consistency to the ratio of peak-to-average modulation levels, and recover the lost modulation.

For proper operation, the composite clipper must be placed at the FM transmitter. Some stations have attempted to place the unit at the studio between the stereo generator and the STL transmitter. These installations have been counterproductive.

When used primarily as a loudness-enhancement device, the composite clipper, like many pieces of audio processing equipment, allows the broadcaster to make a small increase in the quantity of the audio while making a small compromise in the quality of the signal. When used in moderation, this capability is often desirable. The word "moderation" is important. A little may be desirable. A lot is worse than none at all.

One composite clipper is the model CP-803, manufactured by Modulation Sciences Incorporated (MSI), of Brooklyn, New York. This unit has two front panel indicators: a yellow LED labeled "Normal," and a red LED labeled "Heavy." When using this unit, we recommend adjustment so that the yellow LED is lit approximately 50% of the time and the red LED is never lit.

Composite clipping is more appropriate for some formats than for others. For those formats where high apparent loudness is important, composite clipping may be desirable. These formats include CHR (Contemporary Hit Radio), AOR (Album Oriented Rock), AC (Adult Contemporary), and Urban. Composite clipping is less likely to be

appropriate for formats such as Classical or Easy Listening where faithful audio reproduction is of higher importance than apparent loudness. Composite clipping may or may not be appropriate for Country formats, depending on local market conditions.

Composite clippers generate harmonics of the clipped signal. For the station transmitting only their main channel program material, higher frequency harmonics will fall harmlessly out of the passband of the listeners' receivers. But for the station implementing an SCA, some harmonics will fall within the SCA passband, resulting in main-to-sub-channel crosstalk. This will be evidenced as a popping or frying sound in the SCA receiver.

The greater the degree of composite clipping, the greater the degree of crosstalk. How much crosstalk, if any, may be tolerated into the SCA subchannel depends on the program content in that subchannel. Computer data distribution services are less tolerant to crosstalk than are voice services, such as physicians' update services. Similarly, high speed data services (2400 and 4800 baud) are more sensitive than slow speed (300 and 1200 baud) services.

Lastly, the norm for the market should be considered when deciding whether to clip the composite and, if so, how much to clip. If your signal is head and shoulders above the rest, there may be marginal benefit in composite clipping. Conversely, if most stations in the market are employing a significant amount of composite clipping, a station may have little choice but to attempt to keep up.

In all cases, careful adjustment of the composite clipper is critical.

---

## 2.13 THEORY OF OPERATION

---

The **PRISM II FM** was designed around the philosophy that future significant improvements in broadcast audio processing will have to do with quarter-hour maintenance.

Since the early 1960s, broadcasters have placed a high premium on ever-increasing modulation levels. Each successive generation of audio processor brought higher modulation levels. The time between successive generations also seems to have decreased significantly.

Higher modulation levels meant that the recovered audio at the receiver detector also had a higher value. This higher audio voltage could be used to more effectively mask noise at the receiver. This noise had three components: atmospheric noise over the propagation path, interference from other adjacent or co-channel stations, and thermionic noise within the receiver.

Regardless of the noise source — if one assumes that it is constant and the station can be comfortably listened to until the signal-to-noise ratio falls below a certain constant — if the modulating voltage on a given carrier is doubled, you can travel to the point where the carrier is only half as strong and still receive the signal. This linear relationship holds only for AM. A slightly more complex, non-linear relationship holds true for FM, although the end result is similar.

The end effect of increasing modulation levels was to increase the outer fringe or distance to where the station could be comfortably heard. The greater this distance, and the more people contained within the station's service area, the greater was the station's potential listening audience (cumes).

The primary purpose of audio processing prior to 1983 was to increase potential cumes. Additionally, some broadcasters felt there was some psychological advantage or attraction to listeners to the station which appeared to be the most powerful.

Today, modulation levels are only a percentage point or two away from their permitted maximums. The room simply does not exist for significant additional increases in modulation levels.

The revenue producing ability of a broadcast property is not directly related to the cume audience. Rather, it is nearly proportional to the average audience (frequently called "average-quarter-hour" audience).

Simple logic dictates that if we are to increase the *average* number of listeners while not increasing the *total* number of listeners, we must keep each listener for a longer period of time. The rating services, logically, call this parameter "time spent listening."

Much research has gone into the programming aspects of keeping listeners tuned in for longer periods of time. While programmers constantly seek new positive ways to keep listeners interested, much scrutiny is also given to removing negative program elements, which tend to make listeners tune out. Time spent listening can be increased by removing program elements which listeners find fatiguing.

The **PRISM II FM** was designed with the intent of reducing the electronic fatigue factors which reduce time spent listening. Typically, these can be a brash or squashed sound, an unnatural sound, or similar processing artifacts. To accomplish this, the **PRISM II FM** employs *digital technology* in its control circuits. Previous generations of audio processors employed *analog technology*.

Analog processors could do two things: expand and compress. Digitally controlled processors can do three things: expand, compress, and, if necessary, *do nothing*. This is a major point.

If the level is too high in an analog processor, the processor will compress. The moment the level is no longer too high, the analog processor will expand. Expand is simply the default value of what an analog processor does whenever it is not compressing. As long as the analog processor is fed a normal operating level, it is continually either increasing or decreasing gain. If it is not going up, then it is going down, even if it doesn't have a reason to. Up and down, up and down. It never rests. This translates into a "busy" sound and listener fatigue.

To increase loudness in an analog controlled processor, you shorten the attack and recovery time constants. This increases the density but makes the compression level go up and down all that much faster, making the signal more "busy" than it was before. Up goes listener fatigue and down goes time spent listening.

In an effort to prevent listener burnout, one can decrease the number of gain reversals in a given period by lengthening the time constants, but loudness suffers and the broadcaster has come full circle back to where he started.

This is the classic "You can have loudness or you can have quality but you can't have both" dilemma that broadcasters have been running from since the modulation war was declared. Using digital control, the broadcaster is no longer confined to having a default value of "expand." Now, the default value can be "maintain present gain." A digitally controlled processor can be programmed to expand only when it has a reason. While maintaining an equal or higher modulation level in any given period, the **PRISM II FM** will make only one-third to one-half as many AGC voltage reversals as will an analog processor. The decision whether to expand, compress, or do nothing is made on the M-102 processor card by an LM339N, CMOS comparator. Refer to schematic drawing #8511, "M-102 Digitally Controlled Audio Processor" in Appendix B. Two sections of the LM339N, U2B and U2C, form a window comparator. When the voltage applied to pin 4 exceeds the compression reference voltage on pin 5, a compress action is initiated. When the voltage applied to pin 11 (which is connected to pin 4) falls below the expansion reference voltage on pin 10, an expand action is initiated. When the voltage at pins 4 and 11 is neither higher than that on pin 5 nor less than that on pin 10, no action is initiated and the processor remains at its present gain. This is known as being in the "dead band" or the permissible range.

One can increase the permissible range by increasing the spread between the voltages on pins 10 and 5. Similarly, for a given input signal on pins 11 and 4, increasing the voltage spread between pins 10 and 5 will decrease the number of decisions the circuit will make in a given period.

To be symmetrical, you might expect that you would move one reference voltage up while moving the other down. In the interest of simplicity, the voltage at pin 5 is held constant at 5.0 volts, while the voltage on pin 10 is moved up or down. The range of the voltage on pin 10 is from 2.5 to 4.5 volts.

The control which varies the voltage on pin 10 is the DENSITY control. Accordingly, it is a simple matter to change the character of the **PRISM II FM** with this control by changing the size of the window comparator's permissible area.

---

## 2.14 INTERNAL ADJUSTMENTS

---

No internal user adjustments are available in the **PRISM II FM**. For those who would seek to improve the performance of the **PRISM II FM** by experimenting with different time constants, note that the sealed trim pots inside the unit are not time constants. They are bias adjustments. Tampering with these will break the control loop of the processors and cause them to stop operating.

---

## 2.15 SEPARATE MUSIC AND VOICE PROCESSING SYSTEMS

---

A partial facility is implemented in the **PRISM II FM** to allow "post-mix voice injection." Some stations prefer to process their live announcer microphone separately from their music and recorded sources. Typically, the end goal is to permit the use of a significant amount of equalization on the microphone channel. If subsequently fed through a multi-band processor, the processor will tend to redistribute the spectral energy, negating the function of the equalizer.

The desired end goal is accomplished by feeding the microphone channel into the program circuit at a point after the multi-band processing. Several stations have implemented this configuration, using the summing point on the CX-2 board as the point to introduce the microphone channel.

This was accomplished by connecting a fifth resistor (in addition to the existing four representing the four bands) to the inverting input of the summing amp. This practice has been formalized in the CX-2. A signal introduced at pin 1 of connector Y103 on the CX-2 will be superimposed on the **PRISM II FM's** output.

The gain at this mixing port is determined by the value of R126. Lower values of R126 will produce higher gain. Solder pads are provided for R126 and its position is marked, although it is normally not inserted at the factory, to minimize the possibility of stray noise pickup.

A value of 33K is recommended for R126 if this facility is implemented, although the exact value is not critical. Values less than 10K are discouraged. If more gain appears necessary to establish the desired voice injection level, the level provided to the **PRISM II FM** should be increased.

As described earlier, this is a partial facility for post-mix injection, a convenience for those who would add this feature to their **PRISM II FM**. No provision has been made to get the post-mix signal into the **PRISM II FM** chassis. This task rests with the user making the modification.

The RF and transient protection integrity of the **PRISM II FM** should be preserved. In the past, the method of getting the signal into the chassis has been to "borrow" one or two of the stereo strap lines on the rear panel. As few stations implement the stereo strap function, these conductors, with their attendant RF filters and surge protection, are usually available. Consult the schematics for the FP-1 and the motherboard. These conductors can be intercepted either at the cable connecting the FP-1 and the motherboard, or on the bottom of the motherboard.

In low RF environments, acceptable performance may be achieved by bringing a single, unbalanced conductor into the **PRISM II FM**. The proper connection point is at the motherboard end of the cable which interconnects the CX-2 and the motherboard. A signal introduced on pin #1 is connected through to R126 on the CX-2. There are no traces on the motherboard connecting to pin #1. This conductor "dead-ends" there.

In high RF environments, a balanced input is recommended. A small balanced to unbalanced converter will have to be constructed for installation inside the **PRISM II FM**. This can be made from a TL071 and four resistors.

When implementing post-mix injection of the microphone channel, in addition to the equalization, it is usually necessary to add some type of active processing to the microphone channel. This processing would be located in the circuit after the mike pre-amp, but before it was fed to R126 in the **PRISM II FM**. Without separate processing of its own, the microphone channel would sound underpowered when compared to the music channel. Multi-band processing is generally not required in the microphone channel. A single-channel, fast limiter, and possibly some noise control circuitry is generally all that is required. The Gain Brain and the Kepex by Valley People (Nashville, TN) are popular devices for these applications.

When implementing post-mix injection, the air staff will have little or no control of voice-over levels. As both the music and voice are processed prior to the summation point, which source dominates and by how much is fixed by the output level of the voice channel limiter. For the station attempting to insure uniform voice-overs and air sound from a preoccupied air staff, this can be a desired feature. For the station needing maximum flexibility for control by the air staff, this can be a hinderance.

One alternative is to place the announcer's microphone fader in the line level circuit between the output of the voice channel limiter and the post-mix input of the **PRISM II FM**.

Be certain that the sum of the voice injection and the outputs of the four bands do not cause clipping at the white, front panel test point (TP205 on DB-2). The "sum less than 20" rule of thumb described in Section 2.8.2 is not valid when using post-mix injection. The preferred method is to observe the waveform on TP205 with an oscilloscope. There is one other consideration, not readily obvious, which must be kept in mind when contemplating separate voice channel processing. Similar provisions must be made on the backup audio chain. More than one station has installed separate voice and music processing systems only to switch to the backup system many months later, and wonder why the announcer's voice was not coming over the air.

Additionally, the voice post-mix input is not operational when the **PRISM II FM** is in **BYPASS** mode. When doing pink noise setup on the **PRISM II FM** where separate voice and music processing is employed, it will be necessary to switch to the backup processing system or confine adjustment to periods when no live announcing is necessary.

Separate channel processing is an involved procedure which affects daily operations in an ongoing fashion. These can be as significant as the hardware considerations. Generally, it is warranted only in larger markets when the operational inconveniences are outweighed by the larger potential rewards of the market.



# SECTION 3

## TROUBLESHOOTING THE PRISM II FM

---

Many test points have been provided in the **PRISM II FM** to facilitate troubleshooting.

Two keys to quick and accurate troubleshooting are provided by Drawing #8611, "Simplified Block Diagram" and Drawing #8612, "PRISM II FM Circuit Boards" in Appendix C. These drawings provide an overview of the entire system at a glance. Drawing #8611 is a functional block diagram and Drawing #8612 is useful as a location diagram.

This troubleshooting section is only intended to serve as a general guide to the system. This section provides non-technical persons with enough information to make basic checks and technical persons with the overview necessary to make quick sense of the schematics.

---

### 3.1 POWER SUPPLY

---

With power applied, check the front panel LEDs labeled "+15V" and "-15V." They should both be lit at a normal brightness and with equal intensity. If one is extinguished or dim, disconnect AC power input to the unit immediately. Disconnect the load from the power supply by disconnecting plug P2 from the connector labeled "J2" of the PS-2A power supply.

Re-apply AC power and measure the +15V and -15V outputs at J2. If they are normal, then one of the other boards in the system is probably loading down the power supply. Isolate the defective board and replace it. Another possibility is that one of the voltage regulators on the PS-2A power supply board is weak. Replace as necessary.

If the +15V and/or -15V outputs of the PS-2A power supply are abnormal, repair or replace the power supply.

---

### 3.2 AUDIO PROCESSOR BANDS

---

Visually observe the action of the LEDs for each band on the front panel while program audio is being fed to the unit. If any band appears to act abnormally with respect to the other bands, swap the M-102 boards around. If the problem follows the M-102 board, then the M-102 audio processor board is probably defective and should be replaced.

**NOTE:** All M-102 audio processor boards are identical. Under normal operation any M-102 board may be exchanged with any other M-102 board in the system.

---

### 3.3 SYMPTOM: NO OUTPUT

---

Connect a signal source to the input of the **PRISM II FM**, and move the front panel **BYPASS** switch (S102) to the **ON** position. Make certain that the **Pink Noise Generator** switch is in the **OFF** position. Make certain that the **Phase Rotator** is in the circuit by placing the jumper at Y301 of the mother board in the **"IN"** position. Adjust the front panel **BYPASS GAIN** (R115) control to the 12 o'clock position. Adjust the four front panel **MIX LEVEL** controls to the 12 o'clock position. Adjust the **INPUT GAIN** control (R101) and the **OUTPUT GAIN** control (R104) to approximately 12 o'clock positions and monitor the output of the **PRISM II FM**. If no signal is present at the output, replace U101 (on the CX-2 Control Board) and/or U301 (on the motherboard) as required. Move the front panel **BYPASS** switch (S102) to the **OFF** position and proceed.

Using an AC or audio voltmeter or oscilloscope and Drawings #8611 and #8612 (Appendix C), inject program material into the input of the **PRISM II FM** as a test signal, and follow the signal flow through the system as described below. Ensure that the test signal is present at each of the test points described below before proceeding to the next test point.

Monitor the **BLUE** test point (TP303) on the motherboard. If no signal is observed, check the input circuitry on the FP-1 Filter Protection board for continuity. Also check for proper operation of U301 and replace it if necessary.

Monitor the **ORANGE** test point (TP305) on the motherboard. If no signal is observed, move the **Phase Rotator** jumper at Y301 to the **BYPASS** position. If the test signal now appears at the **ORANGE** test point (TP305), the **Phase Rotator** is defective and must be repaired. U401 on the motherboard is the only active device in the **Phase Rotator** circuit.

Each of the M-102 audio processing boards has a **BLACK** test point (TP3). Check for the test signal at each of these points. If the test signal fails to appear at the **BLACK** test point (TP3), check for a defective M-102 board or U302, U303, U304, or U305 as required.

Monitor the **RED**, **ORANGE**, **YELLOW**, and **GREEN** test points on the front panel of the unit (TP201, TP202, TP203, and TP204 respectively). If the test signal fails to appear at any of these test points, check U302, U303, U304, or U305 as required. Check U201 as required. Also check the associated **MIX LEVEL** pots (R105, R106, R107, R108) if necessary.

Monitor the **WHITE** test point (TP205) located on the front panel of the **PRISM II FM**. It is labeled "Broadband Sample." If the test signal fails to appear at this point, replace U101.

Monitor the VIOLET test point (TP304) located on the motherboard. If the test signal fails to appear at this point, check for a jumper across pins 4 and 5 of connector Y102 of the CX-2 control board. If the test signal appears at this point but there is still no output from the unit, replace U306.

This completes the basic troubleshooting section. If the steps described here do not allow you to isolate and repair the **PRISM II FM**, call Gertner Customer Support at (801) 975-7200 for further assistance.

## SECTION 4

# RCF-1 REPLACEMENT CARD FIVE

---

The Gentner RCF-1 Replacement Card Five (for FM applications) is a performance enhancement kit for the Orban Optimod 8100A. It consists of the RCF-1 circuit board and a removable metal access panel. Benefits of the RCF-1 include greater modulation density and increased bass response, giving a less processed sound while still maintaining the same loudness derived from the original Orban Card #5.

The RCF-1 was designed specifically for use in Optimod 8100s used in conjunction with two Gentner PRISM II FMs. Increased performance is accomplished by more closely matching the operational characteristics of the Optimod with those of the PRISM II FMs. Use of the RCF-1 in "barefoot" Optimods (those without multi-band preprocessing) is strongly discouraged as the unit may not react favorably to all types of program conditions. Use of the RCF-1 in Optimods preceded by preprocessors other than the PRISM II FM have not been taken into account in the design and will produce unknown results.

The RCF-1 will *not* work with the Orban Optimod 8000.

---

### 4.1 INSTALLATION

---

Installation of the RCF-1 is quite simple and requires less than five minutes. Although adjustment of the RCF-1 and minor readjustment of the PRISM II FMs is likely to be necessary, the air-sound is likely to be sufficiently close to the final product that the Optimod can be returned to the air as soon as the card installation is complete.

#### 4.1.1 RECOMMENDED EQUIPMENT

---

The best operation of the RCF-1 is obtained with the following equipment:

- **An otherwise unmodified Orban Optimod 8100 or 8100A configured for single-site operation**

Some customers with user-supplied modifications to the Optimod card #6 experienced unusual performance when the RCF-1 was installed. An exception to the prohibition of modifications is the removal of the Optimod phase rotators described in "Removing the Phase Rotators in the 8100" on page 2-26. Removal of the Optimod phase rotators will not negatively affect the performance of the RCF-1 as long as the Gentner Phase Rotators are enabled in the PRISM II FMs. The blue plastic jumpers on the Orban cards #6, #8, and #9 should be set for normal (non-XT mode) operation. See Appendix M of the Orban Optimod 8100 Operating Manual for more information. Orban Broadcast offers a final output filter/clipper option card for the Optimod 8100A known as the "zero

with the Gentner RCF-1 has been proven to meet with positive results from broadcasters who transmit one or more SCA channels.

The Optimod should *not* be in a split-site configuration. In the split-site configuration, the HF Limiter card (card #6) will be located at the transmitter and the AGC card (card #5) will be located at the studio. Even minor phase and amplitude anomalies in the telephone lines or dual channel STLs can upset the critical peak level fed to the HF Limiter card by the AGC cards. This does not present a problem since no reason exists to run split-site configuration with the **PRISM II FM/Optimod 8100A** combination.

The purpose for split-site operation is to protect the telephone lines or STLs from being overdriven by program peaks. Placing the Orban accessory chassis at the studio provides level protection for these program circuits. However, as the RCF-1 is intended to be used only in conjunction with two studio-located **PRISM II FMs**, which will provide the program circuit protection, split-site operation of the Optimod is unnecessary.

Accordingly, the RCF-1 will not mount in the Orban split-site chassis. Please refer to the Orban Accessory Chassis Manual Supplement for instructions on returning the split-chassis Optimod to an original single-site unit.

• **Important**

While all modern FM excitors employ a two-speed AFC loop, there are still some excitors in use which have only a single-speed loop. When used with heavily processed audio these excitors are sometimes unable to distinguish between a low bass note and a low frequency AFC correction voltage.

A sudden bass note may unsettle the AFC loop, causing a tearing sound on the air identical to that produced by multipath reception. In the case of multipath reception, the phase-locked-loop (PLL) in the receiver's detector is on the verge of unlocking. In this instance, it is the PLL in the exciter AFC which is on the verge of unlocking. The only remedy short of changing the AFC circuit is to reduce the degree of processing.

#### **4.1.2 INSTALLATION PROCEDURE**

---

The procedure for installing the RCF-1 is as follows:

1. Remove the three hex screws across the top edge of the Optimod 8100. Either a 1/16" or a 2 mm metric hex driver will fit these screws correctly.
2. Tilt down the entire beige front panel (the cards cannot be removed through the smaller opening of the access door).
3. Turn off the AC power. Do *not* remove cards from the Optimod with power applied. The power switch is a white plastic toggle located on the left. As transients produced during power-down at the Optimod's BNC output connector have occasionally unlocked the AFC of the STL transmitter or the FM exciter which follow the Optimod, some engineers remove the output cable prior to power-down. Remember to reconnect it later.

4. Remove the chocolate brown or beige colored access panel by unlocking the Dzus fasteners on the four corners (the color of the panel depends upon the serial number of the Optimod 8100). These are quarter-turn fasteners. Tilt the top of the panel toward you, making sure it does not become caught on the upper lip. This can frequently be accomplished by placing a finger through one of the open holes in the panel and pushing downward. This should compress the two ribbon cables beneath the panel sufficiently for the panel to be removed.
5. Remove the original Orban Card #5 by pulling on the nylon card ejector on the top of the card. Remove it the rest of the way from the card cage and put it in a safe place. It will be necessary to reinstall the card should it become necessary to return the Optimod for factory service at a later date. Orban will (understandably) not perform service on equipment which is not completely of their manufacture.
6. Slide the RCF-1 into the newly vacant slot. Push gently but firmly to insure that it seats in the edge connector at the rear. *Do not force the card.* This could result in damage to the card or the connector or result in a fracture of the motherboard. If the card will not seat easily, remove it and investigate the source of the obstruction. There is some vertical variation among Optimods in the relative positioning of the edge connector and the card guide rails. If a vertical alignment problem is present, clipping a corner of the RCF-1 edge connector with a pair of diagonal cutters may correct this problem. The cut should be about  $\frac{1}{8}$ " and at a 45 degree angle but should not include any of the gold fingers.
7. Without installing the new chocolate brown colored access panel, turn the power switch back on and temporarily tilt the beige front panel up for viewing. Verify that the multimeter reads near 100% in the +15V and -15V positions of the rotary meter selector switch. Also verify that both LEDs on the RCF-1 are illuminated and the gain reduction meters on the Optimod have returned to zero. If no program material is fed to the Optimod, these LEDs should illuminate steady green. If program material continues to be fed to it, both may occasionally flicker red and then return to their normal green. If both the meter and LED conditions are met, proceed. If not, investigate the offending condition.
8. Tilt the beige front panel back down and install the brown Gentner access panel that was provided with the RCF-1. It should be tilted for insertion in the reverse manner that the original was removed. Be certain as you position the panel for final alignment that DS1 and DS2, the two LEDs on the RCF-1, align with the two holes labeled "MAIN FOLLOW BASS" and "BASS FOLLOW MAIN." Anchor the panel by clockwise rotating the four Dzus fasteners. These are identical to the fasteners on the Orban panel and are also quarter-turn fasteners. When properly seated the screwdriver slots should all be similarly aligned, parallel to the ground.

9. *Verify that the two right-hand switches located on cards #6 and #7 are in the OPERATE (up) position and that the RCF-1 switch is in the OPERATE (left) position.* Removal and replacement of the brown panels may have changed the switch settings. If these switches are not checked at this time, it may result in improper operation or a needless trip back to the transmitter site.
10. Close the beige front panel and reinstall the three hex screws.
11. Reconnect the output cable if it was removed in step 3 above.

---

## 4.2 ADJUSTMENT

---

### 4.2.1 THE RCF-1 CONTROLS

---

There are three variable controls, one switch, and two indicators on the RCF-1. The recommended initial settings of the variable controls are indicated on the access panel by a circle around the appropriate number. The controls function as follows:

**CLIPPING** regulates the level of the audio supplied to the clipper diodes. Clockwise rotation of this control increases the level fed to the clipper and the amount of clipping performed. Increased apparent loudness will result. Counterclockwise rotation of this control will produce a less processed sound. The recommended initial setting is 7. While the CLIPPING control is properly labeled on all of the Gentner supplied access panels, on Revision 0 of the RCF-1 this control was silkscreen labeled (on the RCF-1 circuit board) as DENSITY rather than CLIPPING.

**BASS BOOST** controls the proportion of low frequency program material to mid frequency and high frequency material. Clockwise rotation produces more bass response. The recommended initial setting is 8.

**INTERBAND COUPLING** regulates the degree of corrective action taken by the INTERBAND COUPLING module (IBC-1). Counterclockwise rotation causes the maximum amount of interaction between the MASTER and BASS control voltages. Experience has shown that a setting of 0 (maximum coupling) is normally optimal for all formats.

The **PROOF/OPERATE SWITCH**, when in proof mode, inhibits action of the VCAs so that steady-state (tone) measurements may be performed.

**COUPLING ACTION LEDs** indicate the corrective action taken by the IBC-1. These LEDs will glow a steady green with no audio applied. A corrective action taken on the MASTER control voltage by the IBC-1 will cause the MASTER FOLLOW BASS LED to flash red momentarily. A red flash of the BASS FOLLOW MASTER LED indicates a corrective action taken by the IBC-1 on the BASS control voltage. Both LEDs will become less active with more clockwise settings of the INTERBAND COUPLING control. The COUPLING ACTION LEDs do not serve a significant purpose during setup and adjustment. Their primary purpose is as a diagnostic tool. See "Troubleshooting" on page 4-9.

There is no GATE control on the RCF-1. There is need for only one noise gate in an audio system and multiple gates will "fight" with each other. This function is already provided in the PRISM II FMs.

The CLIPPING and BASS BOOST controls do not act instantaneously. They do not directly regulate the VCA control voltages. Rather, they control the threshold voltages fed to the MASTER and BASS PARC modules. As a result, it will take several seconds for changes in these controls to be reflected in the operation of the unit. The proper procedure is to make an exploratory change in one of these controls and then to wait several seconds for the VCA gains to stabilize before evaluating the change.

Few parallels should be drawn between the operation of the RCF-1 controls and those of the original card #5, except that clockwise rotation of both CLIPPING controls will result in a more processed sound. While there are obvious outward similarities, the internal operation of the two cards is very different. You should also not attempt to draw correlations regarding relative knob position between the RCF-1 and the original card #5. A 12 o'clock setting of the RCF-1 CLIPPING control does not necessarily produce the same degree of clipping as a 12 o'clock setting of the original CLIPPING control. Further, while the INTERBAND COUPLING and the BASS COUPLING controls have similar sounding labels, they are not equivalent. The BASS COUPLING control served as a de facto BASS response control. The INTERBAND COUPLING control does not affect spectral balance.

The movement of the left three edgewise front panel meters will, with the RCF-1 installed, differ significantly from the meter action experienced with the original card #5 installed. In particular, the LIMITING meter will now be much less active, seldom moving past 2 dB of gain reduction. This is perfectly normal. Additionally, if significant amounts of BASS BOOST are used, the BASS G/R meter will deflect less than before.

#### 4.2.2 ADJUSTING THE SYSTEM

Make the following settings:

- INTERBAND COUPLING control ..... 0
- CLIPPING control ..... 7
- BASS BOOST control ..... 8
- HF LIMITING control ..... 5
- INPUT ATTENUATORS ..... 6 to 13 dB of gain reduction

Fine tuning the RCF-1 to fit your format is very easy. The following are some suggestions which may aid you in reaching the sound you desire.

The INTERBAND COUPLING control produces little aural change. As stated earlier, this control *does not* provide for bass enhancement as the BASS COUPLING control did on the original Orban Card #5. While the recommended setting on the IBC control is zero, there may be certain situations that sound slightly more dynamic if this control is rotated from the zero setting. Classical formats or very unprocessed stations may find a setting of one to five to be slightly less restrictive. Any setting above five on the IBC control will, for the most part, remove the IBC function from the processing algorithm.



Most stations are looking for a more open, less processed sound. This is more true today than just a few years ago, mainly due to the advent of digital Compact Discs (CDs) and renewed interest in listener fatigue and quarter-hour maintenance. The CLIPPING control on the RCF-1 can provide high loudness with either a dense, tight "electric" sound or an open, dynamic sound. Note, however, that undesirable distortion may result if large amounts of clipping are simultaneously used with high levels of gain reduction. Turning the CLIPPING control more toward zero will increase gain reduction and will decrease clipping. A CLIPPING control setting between 4 and 7 will deliver a sound that feels controlled and consistent.

Used judiciously, this control is very powerful and can maximize loudness, but some cautions are in order.

It is recommended that the following CLIPPING positions are not exceeded, based on the amount of indicated TOTAL gain reduction:

<u>Gain Reduction</u>	<u>CLIPPING</u>
UP to 6 dB	10
6 dB - 8 dB	8
8 dB - 10 dB	7
10 dB - 13 dB	6

Gentner recommends that the Optimod input attenuators be adjusted for a minimum of 6 dB to 8 dB and a maximum of 10 dB to 13 dB peak gain reduction read on the TOTAL meter. The RCF-1 was specifically designed to operate in this range, unlike the Optimod without the RCF-1 installed.

A good, solid bass is even more important today than before. With the cleaner high-end from better recordings, the bass can get lost in the sizzle. The RCF-1 BASS BOOST control has the power to overcome this problem and is very effective.

A setting of 4 on the BASS BOOST control effectively removes any dynamic bass enhancement and will sound closest to the original program material. A setting greater than 5 will increase the dynamic enhancement of the bass.

The BASS BOOST control, like the CLIPPING control, can be abused. Changes in BASS BOOST should be made very slowly and a long listening session should be made prior to further changes. We recommend you listen for a few days on several different types of radios after you make a change to this control. You should be able to get a very solid, punchy bass sound for your format by careful adjustment of this control.

The only limitation we have found on the use of the BASS BOOST control becomes apparent when using nearly the maximum recommended gain reduction and the CLIPPING control setting is higher than that recommended. If your format and market demand a situation as described, you should not exceed a BASS BOOST setting of 7. A setting higher than that may cause low frequency IM distortions to become apparent.

The RCF-1 has no control that directly adjusts the high frequency response. The HF LIMITING control on card 6 can be used to produce some mild high-end differences. With settings low in number (e.g., 1-3), distortion products will be minimized, but a

slightly restricted high-end may occur. Cymbals may sound less exciting and limited in nature but sibilance will be greatly reduced. If your source material is marginal, you may have to use lower settings of the HF LIMITING control.

For stations looking for a very unprocessed sound, and who have exceptional source material (e.g., CDs) and a very clean audio chain, a higher setting of HF LIMITING may be used. This will open up the highs and create a less restricted feel. Adjustment of the HF LIMITING control is very subjective and only close listening will indicate what setting should be used.

Minor readjustment of the **PRISM II FM** mix levels will likely be necessary for optimum performance with the addition of the RCF-1. Some early advertisements for the RCF-1 indicated that no readjustments of the mix levels was required; experience has shown this not to be the case. In particular, greater levels of PRESENCE and HIGH band injection may be required to properly offset the greater bass of the RCF-1 (refer to Appendix A). Spectral mix is market dependent. What works in New York may not be appropriate for Athens, Georgia. Long listening and minor control changes are your best bet for precisely adjusting the audio processing chain.

---

### 4.3 THEORY OF OPERATION

---

The Gentner RCF-1 is a direct, functional replacement for the original Orban Card #5 but with modified operating algorithms. It draws its operating power from the Optimod and has the same pin-out and protocol as the original Card #5 (See the upper left corner of the RCF-1 schematic, Drawing #87001 in Appendix B for call-out of the edge connector pin-out).

During its normal lifetime, the RCF-1 will require no recalibration or adjustment of any but the front panel controls.

Refer to Drawings #87001, #87002 and #87003 in Appendix B. Card 5's purpose is to generate AGC control voltages to regulate the MASTER and BASS band VCAs, located on Orban cards #3 and #4.

The RCF-1 samples the output of the left and right channel MASTER band VCAs and processes them in the MASTER PERCEPTUAL ATTACK and RECOVERY COMPUTER (MASTER PARC module). The MASTER PARC module, in turn, produces a control voltage. The left and right MASTER band samples enter the RCF-1 on edge connector pins "M" and "N" respectively and enter the MASTER PARC module on pins 4 and 6. The uncorrected MASTER control voltage leaves the MASTER PARC module on pin 7. The MASTER PARC module is the upper of three black modules mounted on the RCF-1.

The left and right channel BASS band samples enter the RCF-1 on edge connector pins "R" and "S" and enter the BASS PARC module on pins 4 and 6. The uncorrected BASS control voltage leaves the BASS PARC module on pin 7. The BASS PARC module is the lower of the three black modules.

The uncorrected MASTER and BASS control voltages are then fed to the INTERBAND COUPLING module (IBC-1), the center one of the three black modules. Under most conditions the IBC-1 will simply pass the control voltages through to its output with no change. However, under transient program conditions such as a bass drum beat or cymbal crash where unduly harsh program clipping could occur, the IBC-1 will modify the control voltages to produce a more desirable audio product. The IBC-1's operation differs significantly from that of the original Orban BASS COUPLING circuit in a number of ways. Where the BASS COUPLING circuit can modify only the bass control voltage, the IBC-1 can modify both MASTER and BASS control voltages.

The "corrected" control voltages are then converted to control currents to drive the VCAs on cards #3 and #4. The corrected MASTER control voltage is fed from pin 4 of the IBC-1 module to voltage follower U4A. A sample of the MASTER control voltage feeds edge connector pin "X," which drives the edgewise front panel gain reduction meter labeled COMPRESSION. Linear voltage-to-log current conversion is accomplished in differential pair U7B. The MASTER control current exits the RCF-1 on the "F" edge connector pin.

A sample-and-hold circuit consisting of U5B drives voltage follower U5C, which provides voltage to the front panel TOTAL gain reduction meter via pin "Y" on the edge connector. (There is no lead to drive the front panel LIMITING meter as it is multiplexed from the two existing lines by the Optimod metering PC board.)

The corrected BASS control voltage is fed from pin 1 of the IBC-1 to voltage follower U4B, which drives the front panel TOTAL BASS gain reduction meter via the "W" edge connector pin. The output of voltage follower U4B is also linear voltage-to-log current converted in differential pair U7A.

U6A and U6B maintain the desired static currents through the MASTER and BASS differential pairs respectively. R26 and R32 are factory adjustments which set the static currents to produce the desired quiescent gain in the VCAs when no AGC voltage is present.

U1 is a thermally compensated, precision voltage reference which supplies a precise 2.50 volt for reference use on the RCF-1. Its output is voltage followed by U2B. This voltage drives U5A and U5D which provide -1.200 and +1.200 volts to the clipper diodes located on Orban cards #3 and #4. The 2.50 volt source also feeds variable-gain amplifier U2D and subsequently U3A, which provide the variable CLIPPING reference voltage to the MASTER PARC module. The 2.50 volt reference also drives variable-gain amplifier U2A, which supplies the INTERBAND COUPLING reference voltage to the IBC-1 module. Variable-gain stage U2C samples the CLIPPING reference voltage and provides, through voltage-follower U3B, a BASS BOOST reference to the BASS PARC module. Notice that the voltage at the output of U3B is dependent not only on the position of R15, the BASS BOOST control, but also on the position of R10, the CLIPPING control. The physical significance of this is that, as the CLIPPING control is varied, the clipping depths of the MASTER and BASS bands will track up and down together in proportion to each other. The BASS BOOST control will affect only the ratio of BASS to MASTER band program material.

To place the RCF-1 in PROOF mode, switch S1 places +15 volts on the inputs to voltage-followers U3A and U3B, forcing the CLIPPING and BASS BOOST reference voltages to high levels. This places the threshold for VCA voltage generation in the PARC modules at an unreachable level, insuring that no AGC action will take place. The PROOF mode switch also places +15 volts on the input to voltage follower U5D, pushing the clipper diode bias voltages on edge connector pins "H" and "J" from their normal levels to +15 volts and -15 volts respectively. This also is an unreachable level, insuring that no clipping will occur.

---

## 4.4 TROUBLESHOOTING

---

If you should experience problems with the RCF-1/Optimod 8100 combination, the first step is to determine if the problem is contained in the RCF-1 or the Optimod itself. This can easily be accomplished by temporarily replacing the RCF-1 with the original Orban Card #5. If the condition persists, the problem lies in the Optimod itself. If the condition is corrected, the problem is in the RCF-1.

- **IMPORTANT** The RCF-1 is not an Orban Broadcast product. *Do not call Orban Broadcast for assistance with Gentner's RCF-1 Replacement Card Five. For factory assistance, contact Gentner's Customer Support Department at (801) 975-7200.*

Should your Optimod need to be returned to the Orban factory for repairs or realignment, do not ship the Optimod with the RCF-1 installed as it will not conform to the protocol of the Orban alignment and test fixtures. The original Orban Card #5 should be reinstalled for such a return.

A simple test for the likely proper functioning of the RCF-1 is to observe DS-1 and DS-2, the LEDs labeled MAIN FOLLOW BASS and BASS FOLLOW MAIN. With the INTERBAND COUPLING control fully counterclockwise (setting 0) and active program material applied to produce nominal compression (about 8 dB), these LEDs should occasionally flicker from their normal green to a momentary red and back. While not a complete and thorough test, the above condition is a statistically good indication that the RCF-1 is operating properly. These results, however, do not necessarily indicate that either the RCF-1 or the rest of the audio system is properly adjusted. Note also that the BASS FOLLOW MAIN indicator will be the more active of the two, changing color much more frequently than the MAIN FOLLOW BASS indicator. This is a normal condition.

If a problem is verified and it has been isolated to the RCF-1, the card extender will be invaluable in locating the condition. The card extender is normally stored in an empty slot in the Optimod located to the left of Card #3 and against the power supply partition. Remove the brown access panel as described in "Installation Procedure" on page 4-2. Be sure to turn the power switch off, then remove the RCF-1. Remove the card extender from the storage slot and place it in the slot vacated by the RCF-1. Insert the RCF-1 in the card extender with the components facing to the left (the number 5 on the card ejector should be upright). Turn the power back on. Consult Drawing #87001, schematic for the RCF-1 in Appendix B.

To allow convenient troubleshooting, eleven operational voltages of the RCF-1 plus ground are brought out to test and align connector Y1. Pin-out of the connector is described in the lower left corner of the above referenced schematic. Pin 1 of the connector is closest to the Optimod. Pin 12 is closest to the user. While scope "hook probes" conveniently grasp the L-shaped pins for troubleshooting, frequently the ground clip of the scope probe is too large to connect without shorting pin 12 to pin 11. A convenient place to connect this lead to ground is at the top lead to C2, one of the electrolytic capacitors at the top rear of the RCF-1 and the one closest to the user.

Make sure the PROOF/OPERATE switch is in the OPERATE (left) position. Proceed to check the following voltages. If any are not within the recommended ranges, consult the schematic for the logical location of the defective component. Verify that there are +2.50 volts present at pin 1 of Y1. Connect the meter or oscilloscope to Y1-2. This voltage should vary from +2.45 volts to +3.70 volts as you rotate the CLIPPING CONTROL from the left stop on the potentiometer to the right stop. (The CLIPPING control, R10, was silkscreened on early RCF-1 boards as the DENSITY control.) Verify that -1.20 volts is present at Y1-3. The voltage on Y1-4 should vary from -0.4 volts to -1.25 volts as the INTERBAND COUPLING control is rotated from full left rotation to full right. Place the CLIPPING control in its full counterclockwise position. The voltage on Y1-5 should vary from +0.85 volts to +2.60 volts when the BASS BOOST control is rotated from full left to full right. Tolerance for these measurements is plus or minus 10%.

You should observe nearly ground potential at Y1-6 and Y1-7 when no program material is applied. With program material applied, you should notice time-varying, negative-going voltages on both of these. The exact voltage will vary depending on the amount of compression but it will be on the order of several volts. These are the "uncorrected" control voltages. The BASS control voltage, found on Y1-7, should move somewhat more slowly than the MASTER control voltage. The waveform on Y1-8 should mimic the voltage on Y1-6 almost identically. As described earlier under Theory of Operation, these voltages are unequal only during the momentary actions of the Interband Coupling Module (IBC-1). The voltage on Y1-8 will be unequal to the voltage on Y1-6 only when the BASS FOLLOW MAIN LED changes color from green to red. Similarly, the voltage on Y1-9 should be nearly identical to the voltage on Y1-7. They will be unequal only when the MAIN FOLLOW BASS LED changes from green to red.

Y1-10 and Y1-11 are provided for factory calibration of R26 and R32. They provide little troubleshooting information and may be ignored.

Further diagnosis can be accomplished by a qualified technician. Consult Gentner's Customer Support department at (801) 975-7200 for further assistance.

# APPENDIX A

## RECOMMENDED SETTINGS

---

The following is a tabulation of MIX LEVEL settings which have been used successfully in the field. The readings were taken with a Simpson 260 VOM. A Potomac Instruments AA-51 Audio Analyzer may be used in place of the Simpson 260.

**NOTE:** These settings should only be regarded as a starting point. Ultimately, settings will need to be fine-tuned using subjective listening tests.

**NOTE:** The following readings are in dBm, *not* volts.

Use the innermost scale on the Simpson 260 and the 2.5 VAC range.

Use the outermost scale on the Potomac Instrument AA-51.

EQUIPMENT USED	LOW BAND	MID BAND	PRESENCE BAND	HIGH BAND
ORBAN 8100A (Factory Stock)	5.0	4.0	4.0	3.0
ORBAN 8100A (Equipped with RCF-1)	4.0	4.0	4.0	4.0
ORBAN 8000A	3.0	3.0	3.0	4.0
GENTNER LAZER	4.0	4.0	3.0	3.0

For a discussion of setting the MIX LEVEL controls, see section 2.8.2, Setting the Mix Levels.

FM users should also see the text in section 2.12.2, Composite Clippers.

A.1 SETUP LOG

Date & Time	MIX LEVELS (dBm)				Input Gain	Gate	Density	Output Gain	Comments	Initials
	Low Band	Mid Band	Pres Band	High Band						
Example	4.0	4.0	4.0	4.0	12 o'clock	0.5 VDC	4.25 VDC	12 o'clock	Starting point	

# APPENDIX B

## SCHEMATICS AND BLOCK DIAGRAMS

---

The following is a list of schematics and block diagrams in this appendix.

1. Circuit Board Location Diagram for the **PRISM II FM**
2. Simplified Functional Block Diagram for the **PRISM II FM**
3. Schematic: CX-2 Control Board
4. Schematic: DB-2 Display Board
5. Schematic: FP-1 Filter and Protection Board
6. Schematic: PS-2A Power Supply
7. Schematic: M-102 Digitally Controlled Audio Processor
8. Schematic: MB-2 Motherboard (1 of 2)  
Schematic: MB-2 Motherboard (2 of 2)
9. RCF-1 Replacement Card Five Block Diagram
10. Schematic: RCF-1 Replacement Card Five
11. Orban Optimod 8100 Block Diagram



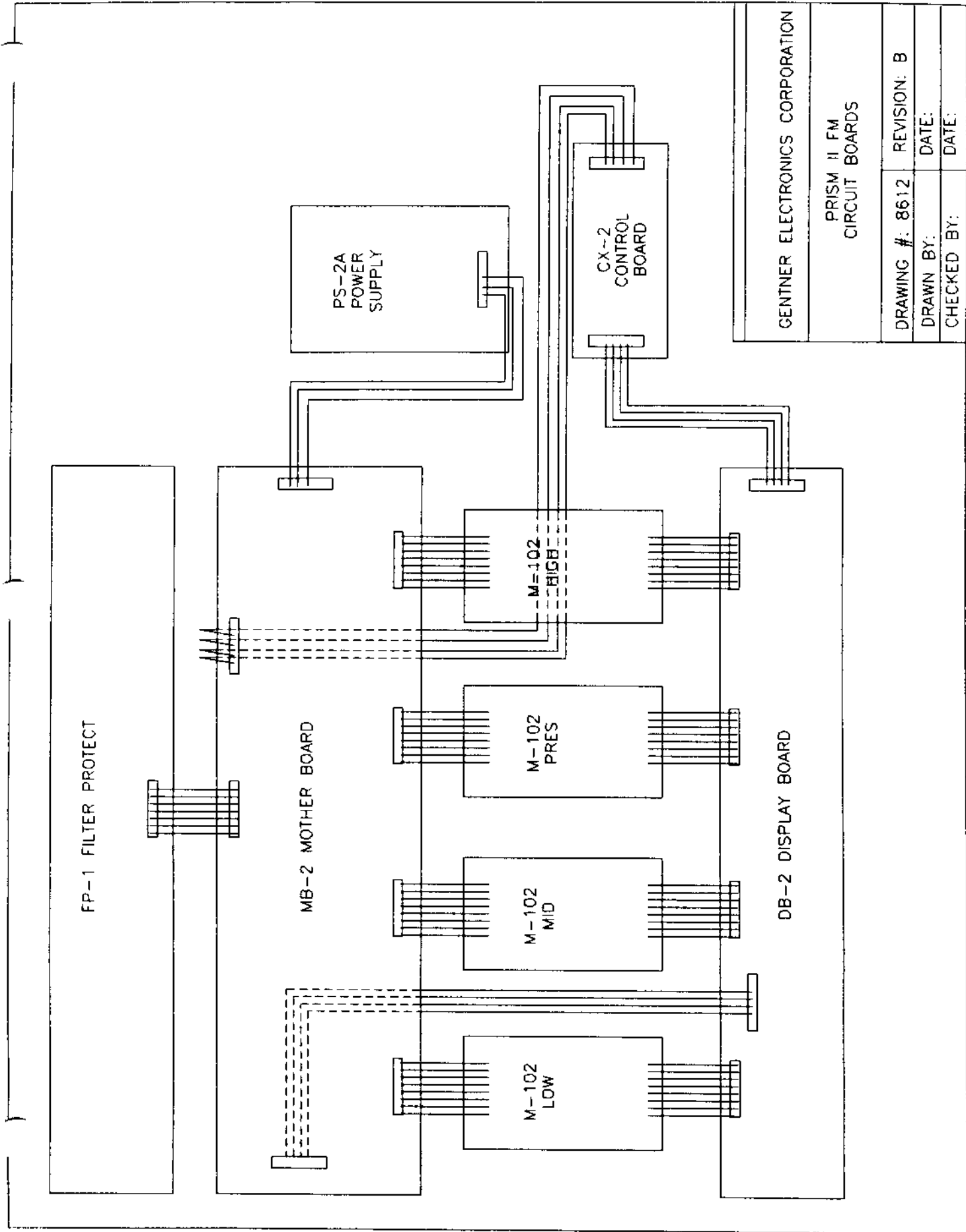

GENTNER ELECTRONICS CORPORATION

PRISM II FM  
CIRCUIT BOARDS

DRAWING #:	8612	REVISION:	B
DRAWN BY:		DATE:	
CHECKED BY:		DATE:	

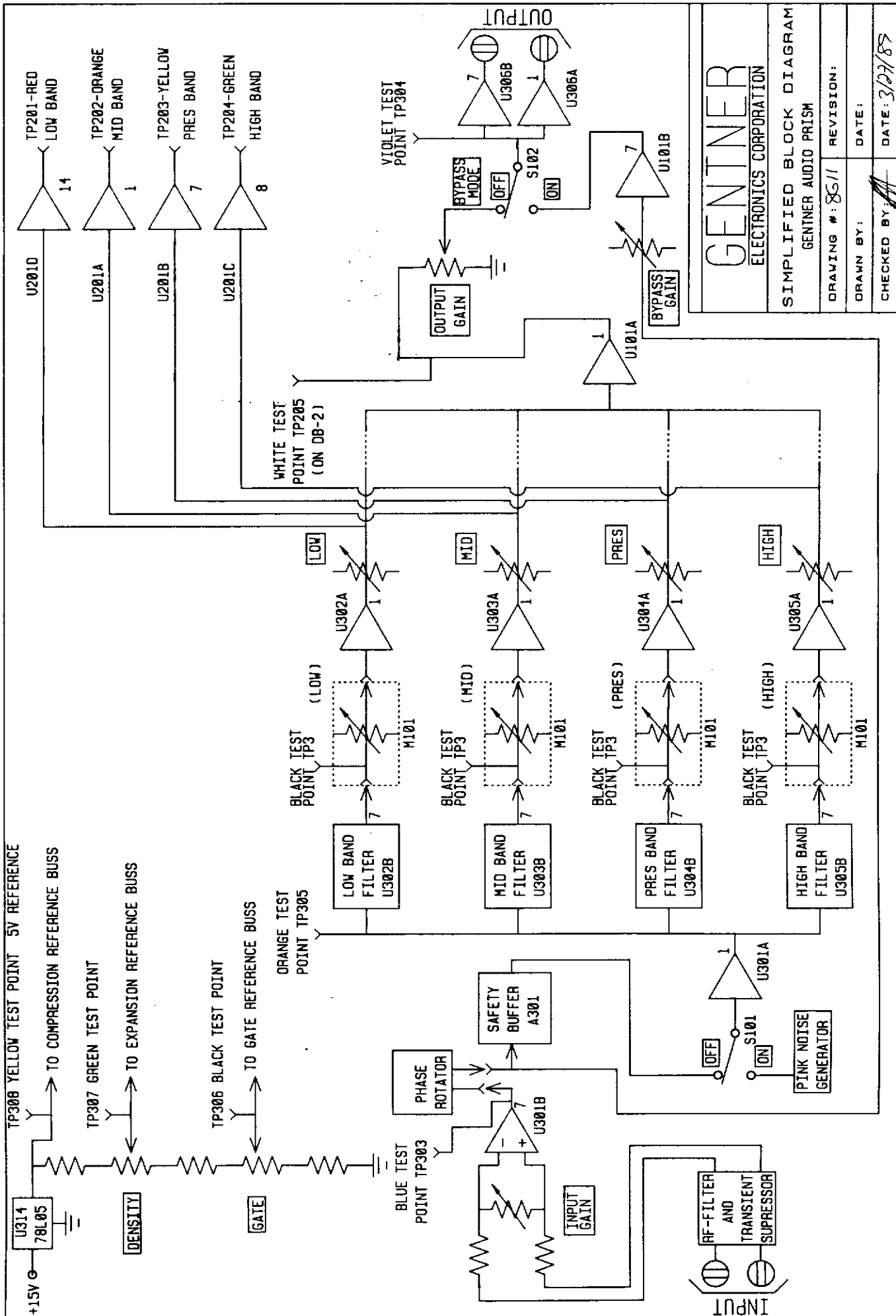

**GENTNER**  
ELECTRONICS CORPORATION

SIMPLIFIED BLOCK DIAGRAM  
GENTNER AUDIO PRISM

DRAWING #:	8611	REVISION:	
DRAWN BY:		DATE:	
CHECKED BY:		DATE:	3/27/85

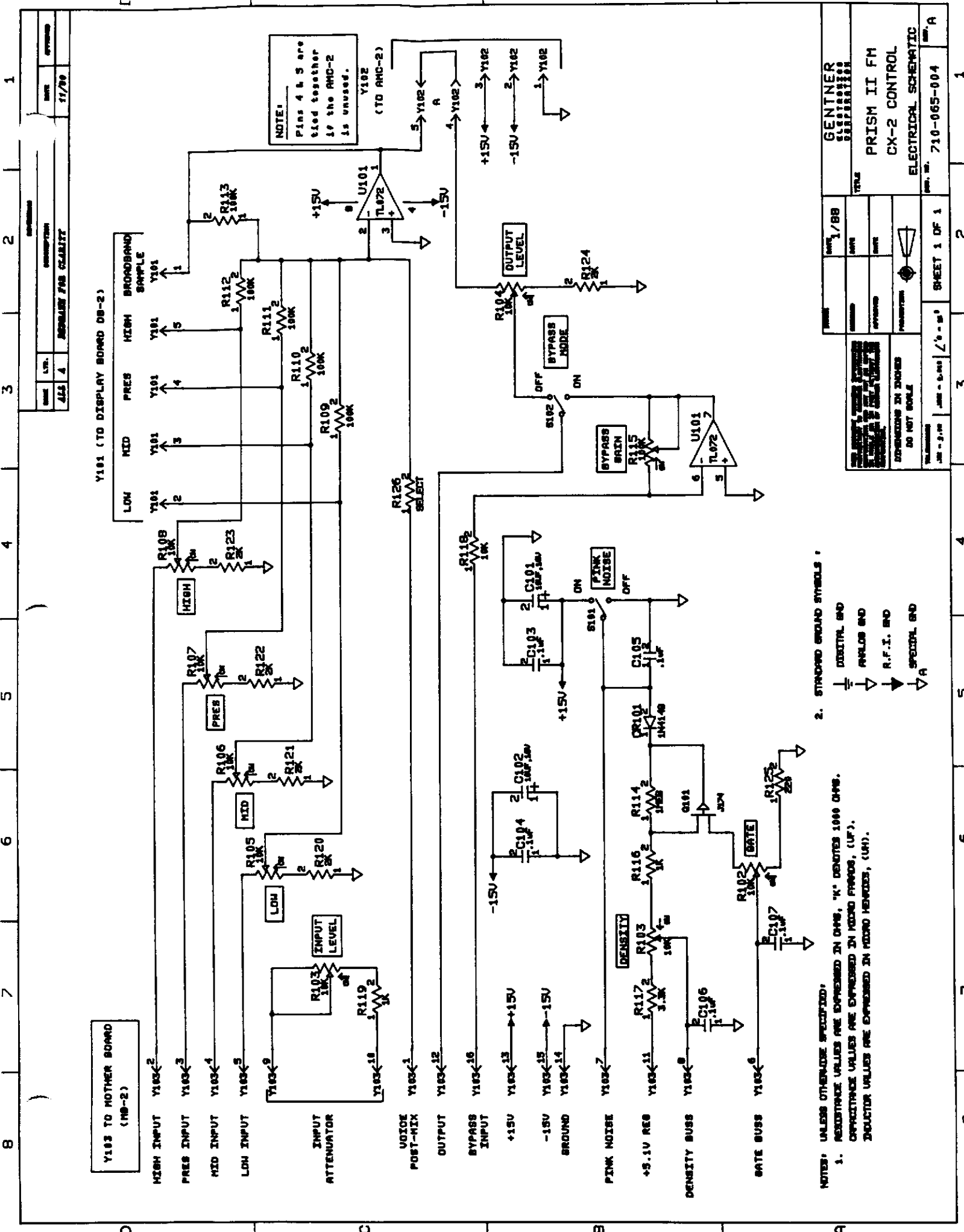

DATE	REV.	DESCRIPTION	APPROVED
4/15/70	4	REPAIR FMS CLARITY	11/70

1 2 3 4 5 6 7 8

**NOTES:** UNLESS OTHERWISE SPECIFIED:  
 1. RESISTANCE VALUES ARE EXPRESSED IN OHMS, "K" DENOTES 1000 OHMS.  
 CAPACITANCE VALUES ARE EXPRESSED IN MICRO FARADS, (UF).  
 INDUCTOR VALUES ARE EXPRESSED IN MICRO HENRYS, (UH).

2. STANDARD GROUND SYMBOLS:  
 ⊥ DIGITAL GND  
 ▽ ANALOG GND  
 ▾ R.F.I. GND  
 ▾ SPECIAL GND

**GENTNER**  
 PRISM II FM  
 CX-2 CONTROL  
 ELECTRICAL SCHEMATIC  
 SHEET 1 OF 1  
 710-065-004  
 REV. A

A B C D

R201 THRU R220  
 DEPENDS ON  
 BAND

LED KEY:  
 G - GREEN  
 R - RED  
 Y - YELLOW

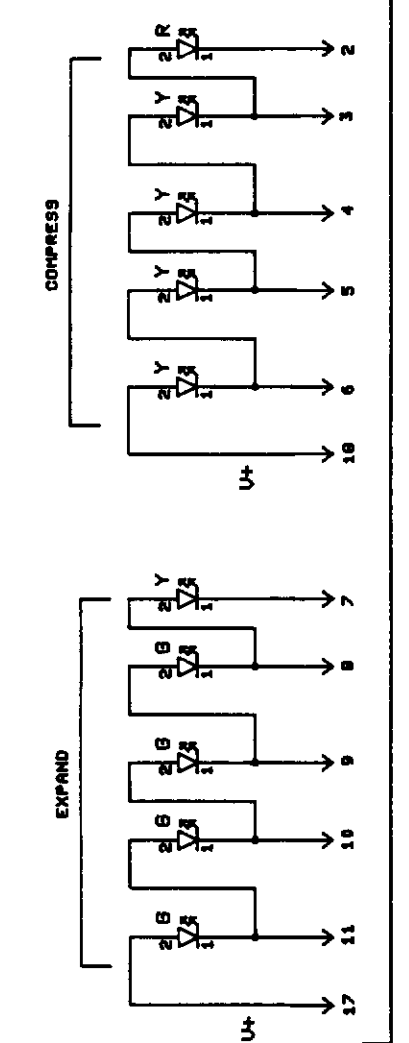
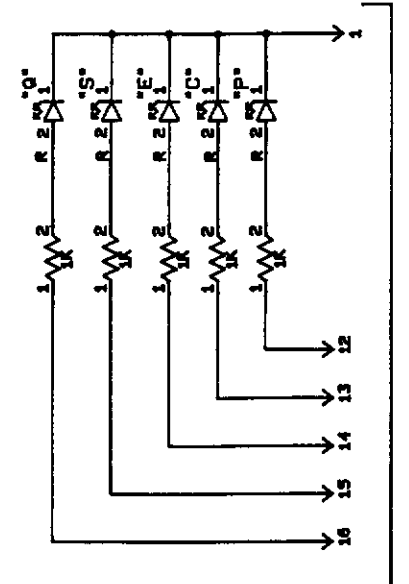

ONE OF FOUR IDENTICAL DISPLAY CLUSTERS  
 REPEAT 3 TIMES FOR TOTAL OF 4. ONE FOR EACH BAND

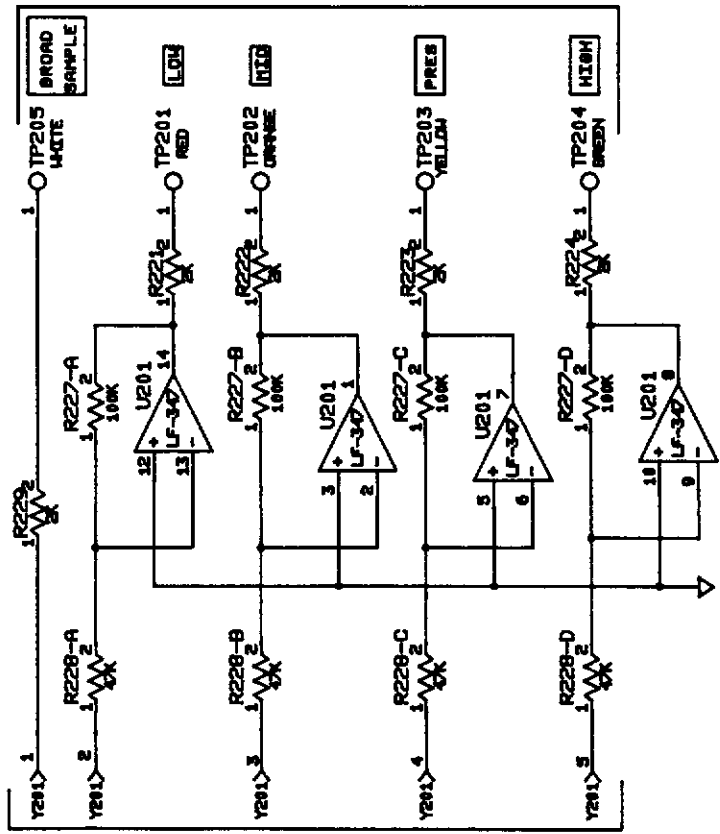

FRONT  
 PANEL  
 TEST  
 POINTS

Y201  
 FROM  
 CX-2

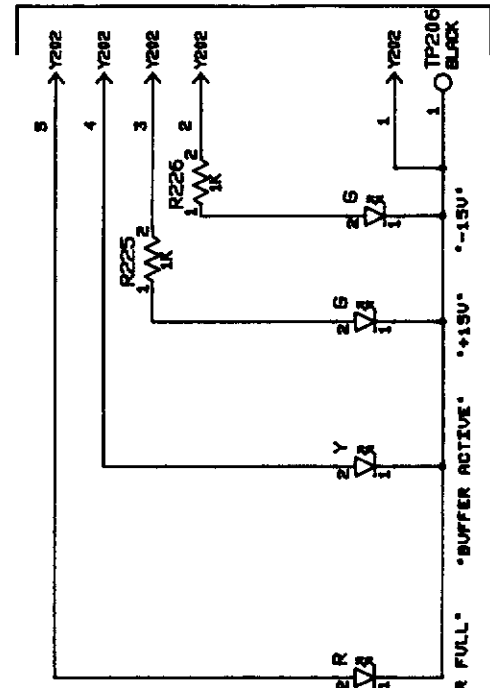

Y202  
 TO  
 MOTHER  
 BOARD

- NOTES:
- UNLESS OTHERWISE SPECIFIED,
    - RESISTANCE VALUES ARE EXPRESSED IN OHMS, "K" DENOTES 1000 OHMS.
    - CAPACITANCE VALUES ARE EXPRESSED IN PICO FARADS, (PF).
    - INDUCTOR VALUES ARE EXPRESSED IN MICRO HENRIES, (UH).
  - STANDARD GROUND SYMBOLS:
    - DIGITAL GND
    - ANALOG GND
    - R.F.I. GND
    - SPECIAL GND

DATE: 1/88  
 TITLE: GENTNER  
 PRISM II FM  
 DB-2 DISPLAY  
 ELECTRICAL SCHEMATIC  
 SHEET 1 OF 1  
 710-065-005

DATE	REV.	DESCRIPTION	APPROVED
ALL A	4	REWORK FOR CLARITY	11/79

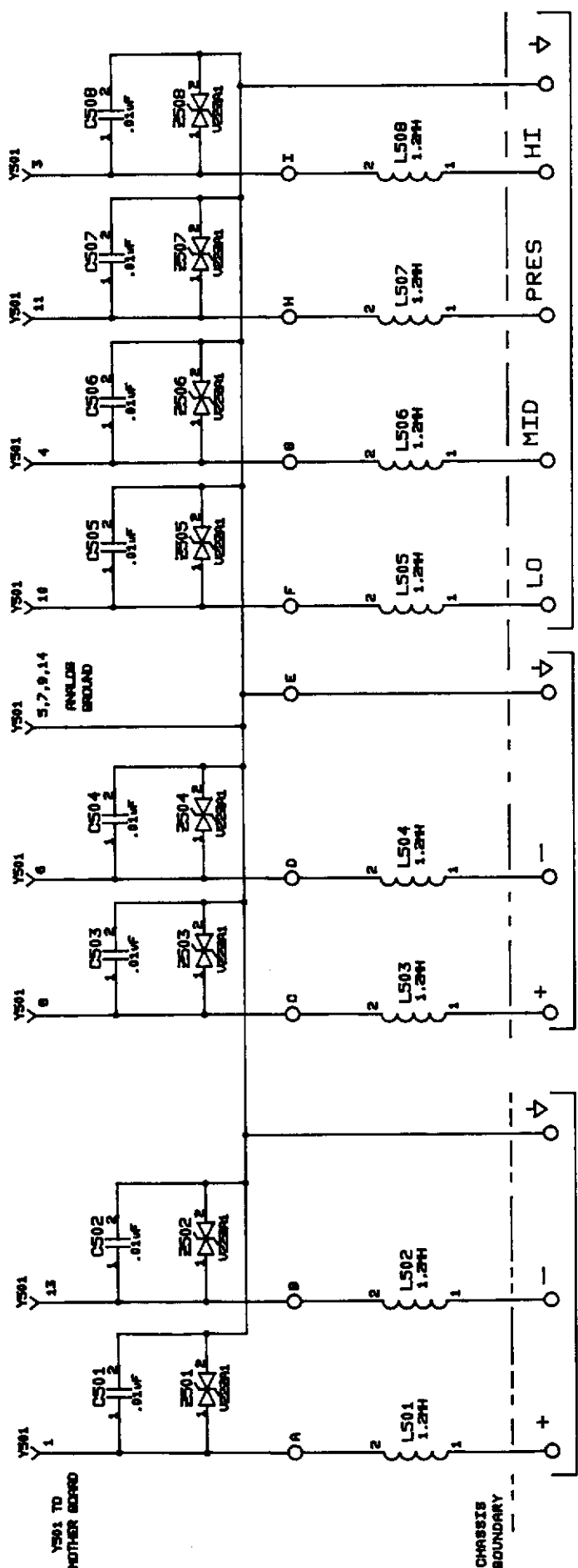

STEREO STRAPS

OUTPUT

INPUT

TB501 REAR APRON BARRIER STRIP

- NOTES: UNLESS OTHERWISE SPECIFIED:
- RESISTANCE VALUES ARE EXPRESSED IN OHMS, "K" DENOTES 1000 OHMS.  
CAPACITANCE VALUES ARE EXPRESSED IN MICRO FARADS, (UF).  
INDUCTOR VALUES ARE EXPRESSED IN MICRO HENRIES, (UH).
  - STANDARD GROUND SYMBOLS:
    - ↓ DIGITAL GND
    - ▽ ANALOG GND
    - ▽ R.F.I. GND
    - ▽ SPECIAL GND

DATE	REV.	DESCRIPTION	APPROVED
1/88			
GENTNER ELECTRONICS CORPORATION			
PRISM II FM FP-1			
FILTER & PROTECTION ELECTRICAL SCHEMATIC			
SHEET 1 OF 1			
PART NO. 710-065-006			

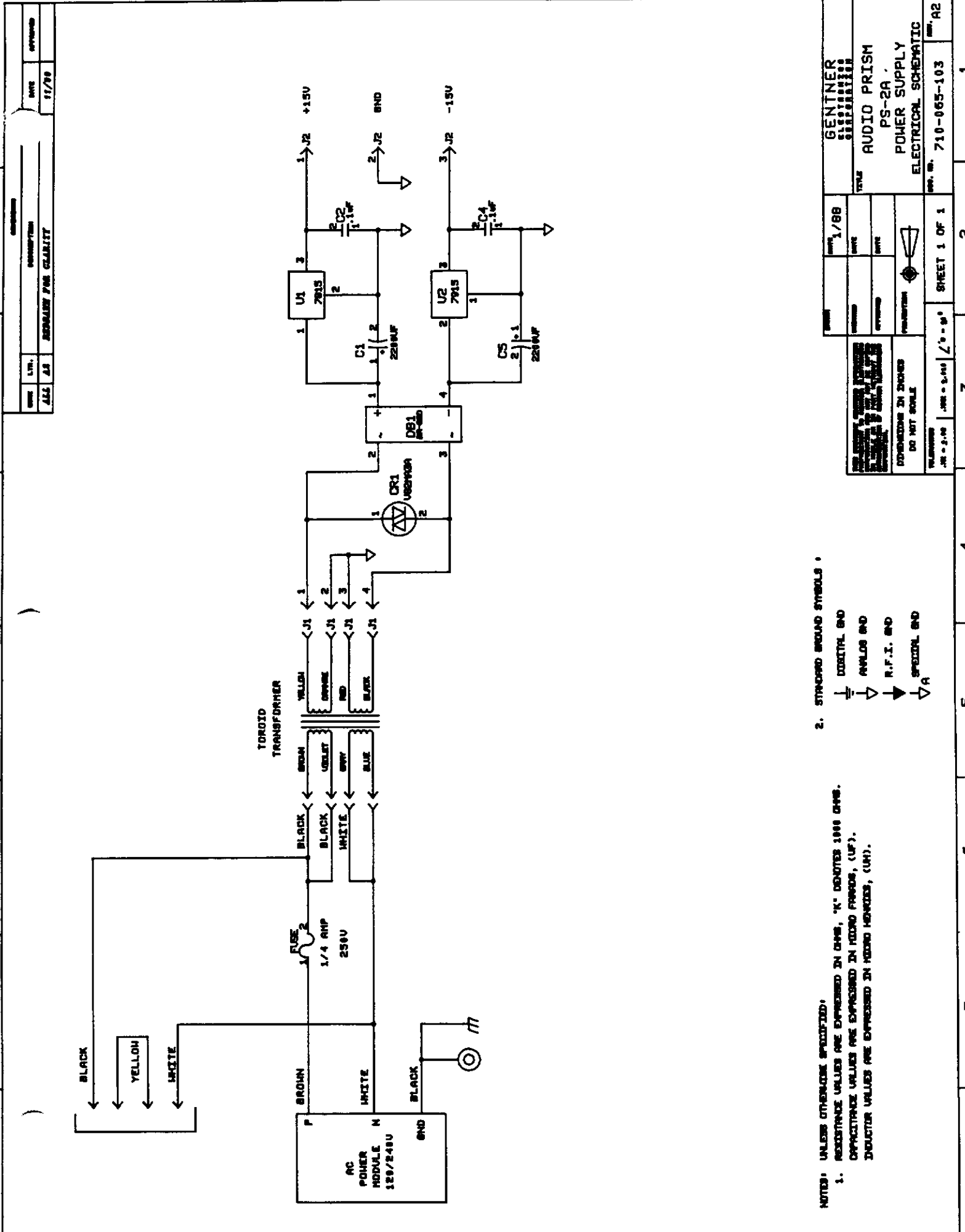

DATE	REV.	DESCRIPTION	DATE	APPROVED
4/11/88	AS	REWORK FOR CLARITY	11/79	

- NOTES: UNLESS OTHERWISE SPECIFIED:
- RESISTANCE VALUES ARE EXPRESSED IN OHMS, "K" DENOTES 1000 OHMS. CAPACITANCE VALUES ARE EXPRESSED IN MICRO FARADS, (UF). INDUCTOR VALUES ARE EXPRESSED IN MICRO HENRIES, (UH).
2. STANDARD GROUND SYMBOLS:
- ↓ DIGITAL GND
  - ▽ ANALOG GND
  - ▶ R.F.I. GND
  - ▽ A SPECIAL GND

DATE	REV.	DESCRIPTION	DATE	APPROVED
1/88				

GENTNER ELECTRONIC CORPORATION	
AUDIO PRISM PS-2A POWER SUPPLY ELECTRICAL SCHEMATIC	
APP. NO. 710-065-103	

DATE	REV.	DESCRIPTION	DATE	APPROVED
1/88				
DIMENSIONS IN INCHES DO NOT SCALE				
SHEET 1 OF 1				



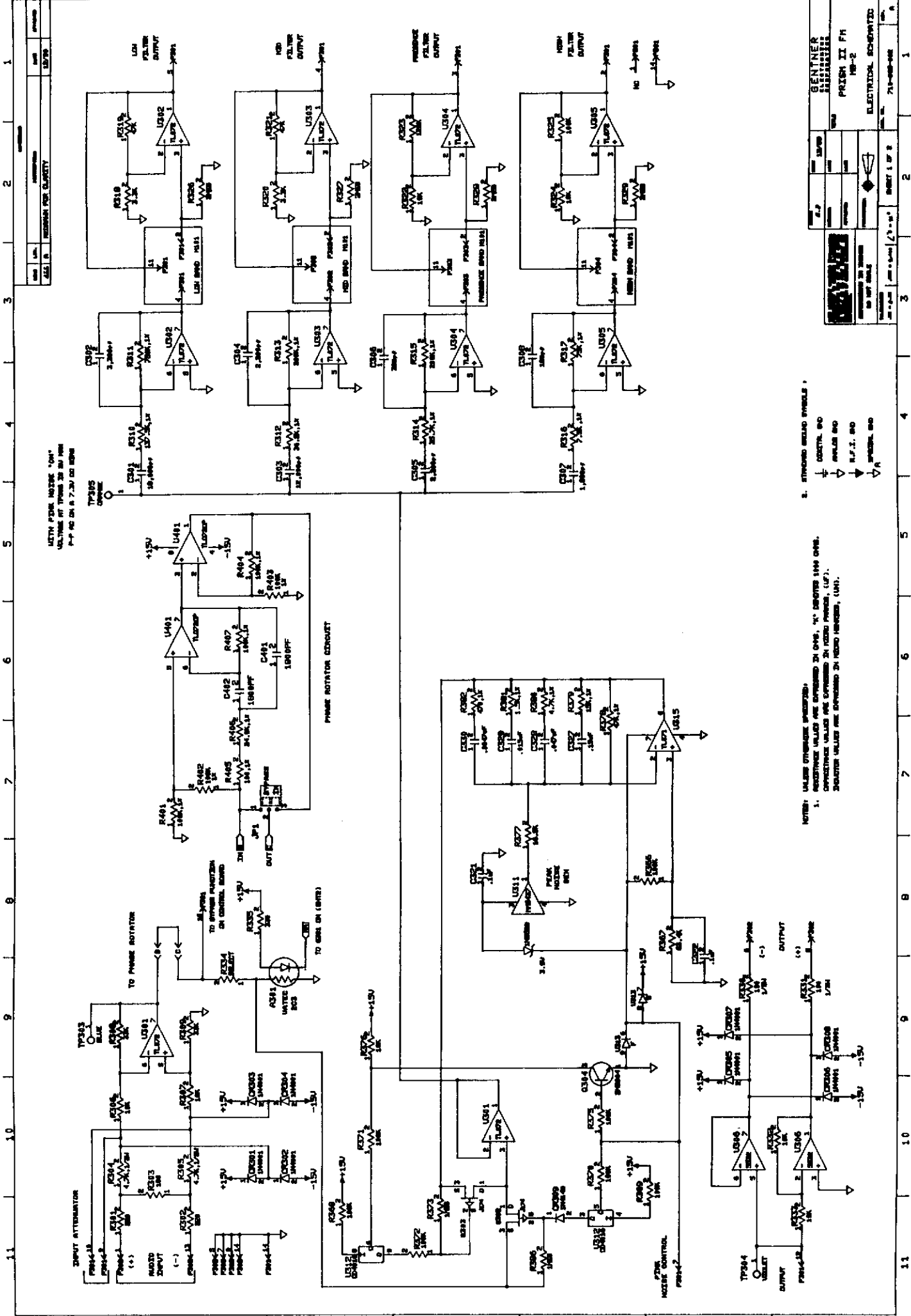

LEAKY PEEK NOISE "OH"  
 VOLTAGE AT TP943 IS 200 MVR  
 P-P NOISE ON 7.3M/ 0.5M

PRIME ROTATOR CIRCUIT

2. STRONGER SIGNAL SYMBOLS

1. WEAKER SIGNAL SYMBOLS

REV	DATE	BY	CHKD	APP'D
1	10/1/50	J. W. B.	J. W. B.	J. W. B.
<p>GEN. ENG. DIV.          AIR FORCE ELECTRONIC RESEARCH          DEVELOPMENT CENTER          WRIGHT-PATTERSON AIR FORCE          BASE, OHIO</p>				
<p>PROJECT II, FM          HW-2</p>				
<p>ELECTRICAL SCHEMATIC</p>				
SHEET 1 OF 2			71-400-001	1



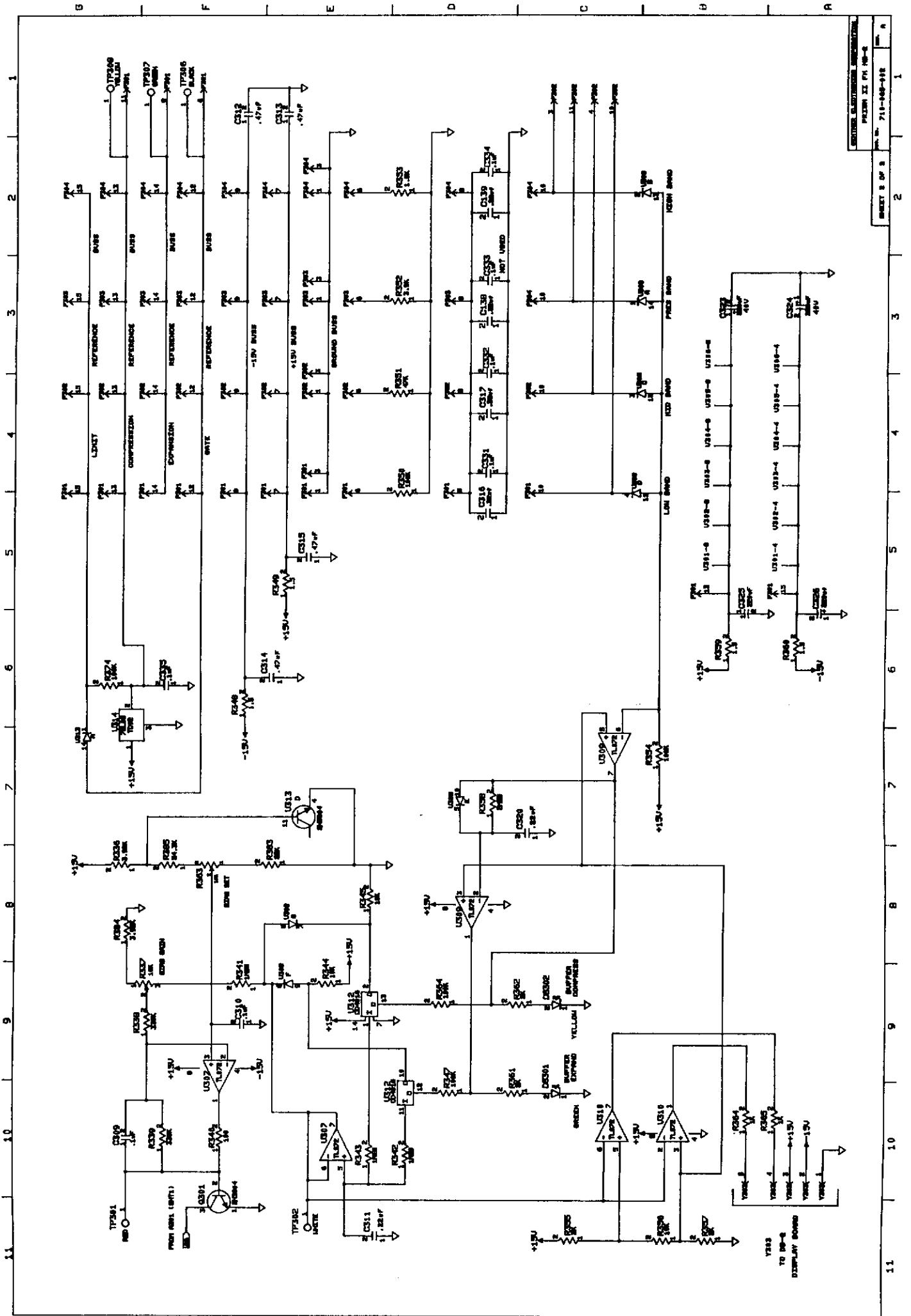

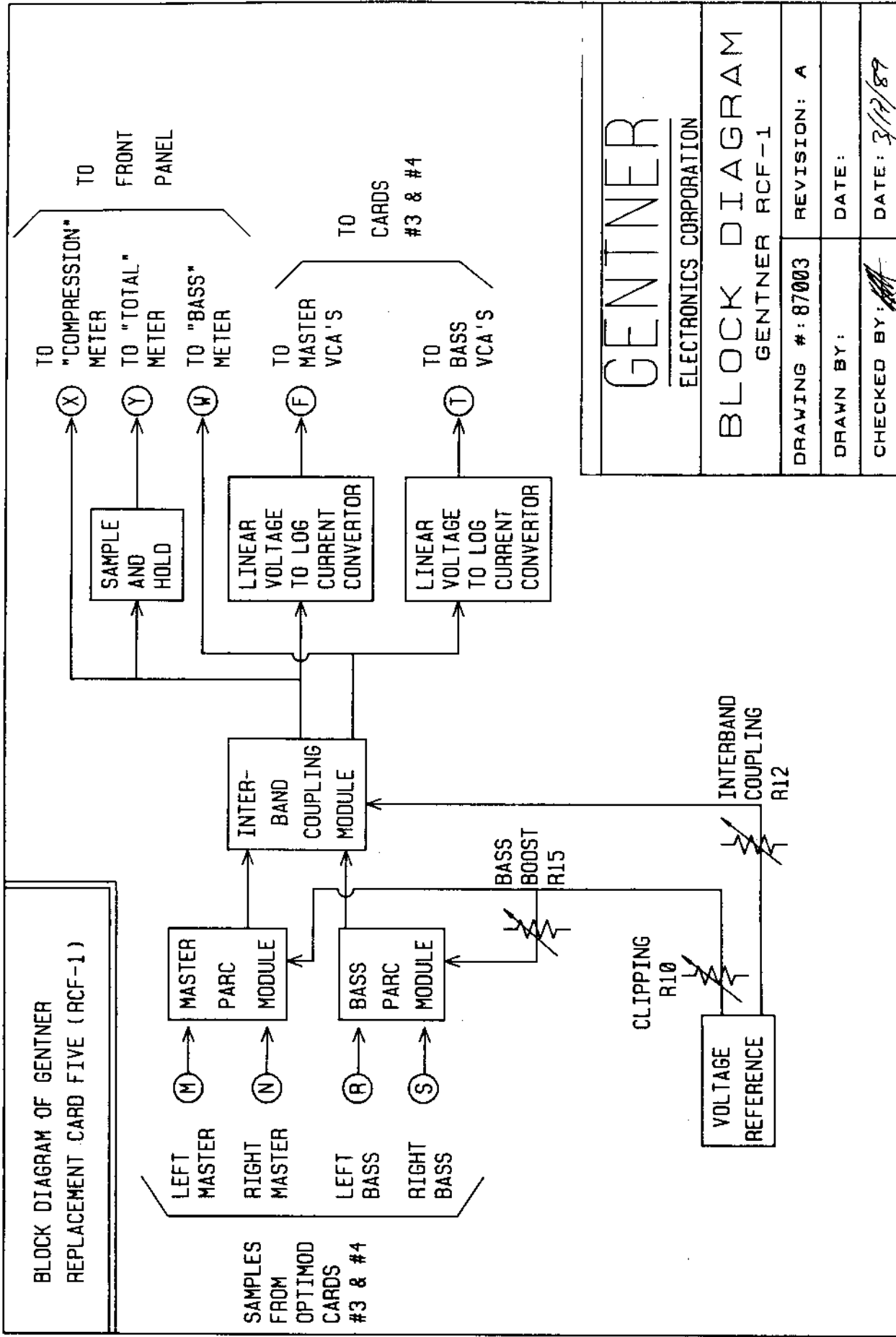

**GENTNER**  
ELECTRONICS CORPORATION

**BLOCK DIAGRAM**  
GENTNER RCF-1

DRAWING #: 87003	REVISION: A
DRAWN BY:	DATE:
CHECKED BY:	DATE: 3/12/89

### EDGE CONNECTOR PIN OUTS

- ① CHASSIS GROUND
- ② -15 VOLTS
- ③ SIGNAL GROUND
- ④ N/C
- ⑤ MASTER I CONTROL
- ⑥ +1.200 VOLTS TO CLIPPER
- ⑦ -1.200 VOLTS TO CLIPPER
- ⑧ N/C
- ⑨ LEFT MASTER SAMPLE
- ⑩ RIGHT MASTER SAMPLE
- ⑪ LEFT BASS SAMPLE
- ⑫ RIGHT BASS SAMPLE
- ⑬ BASS I CONTROL
- ⑭ N/C
- ⑮ BASS METERING
- ⑯ COMPRESSION METERING
- ⑰ TOTAL METERING
- ⑱ N/C

Last Used	Not Used
C11 R41	R11
C48 U7	R1N
J52	

### TEST CONNECTOR PIN OUTS

- Y1-1 2.500 Volt Reference
- Y1-2 Clipping Reference
- Y1-3 Clipper Bias
- Y1-4 Coupling Reference
- Y1-5 Bass Boost Reference
- Y1-6 Uncorrected Master Voltage
- Y1-7 Uncorrected Bass Voltage
- Y1-8 Corrected Master Voltage
- Y1-9 Corrected Bass Voltage
- Y1-10 Master
- Y1-11 Bass
- Y1-12 Signal Ground

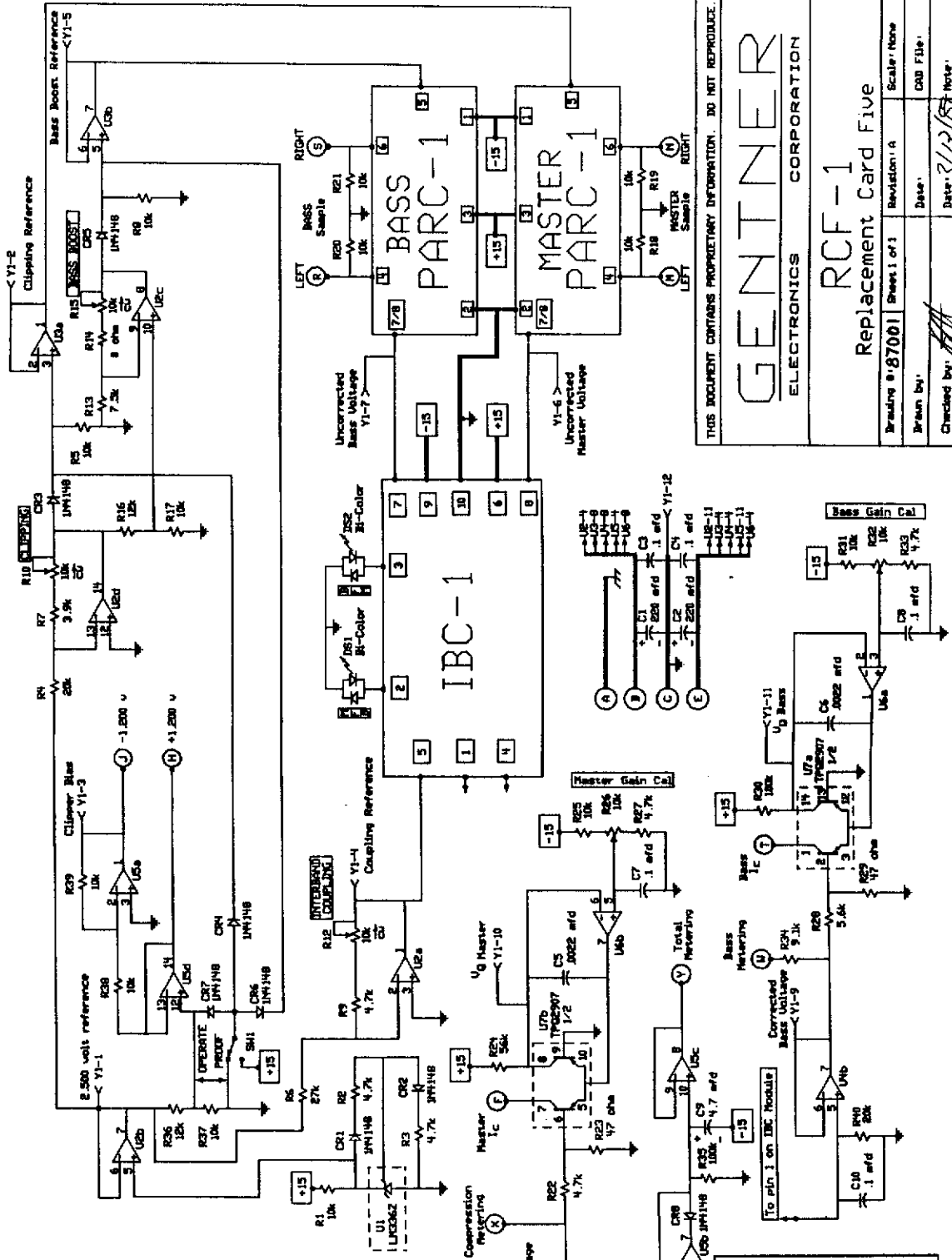

THIS DOCUMENT CONTAINS PROPRIETARY INFORMATION. DO NOT REPRODUCE.

# GENTNER

ELECTRONICS CORPORATION

## RCF-1

### Replacement Card Five

Drawing # 870011	Sheet 1 of 1	Revision: A	Scale: None
Drawn by:	Date:	Checked by:	CAD File:
			Date: 3/17/87

BLOCK DIAGRAM OF ORBAN OPTIMOD 8100 \*

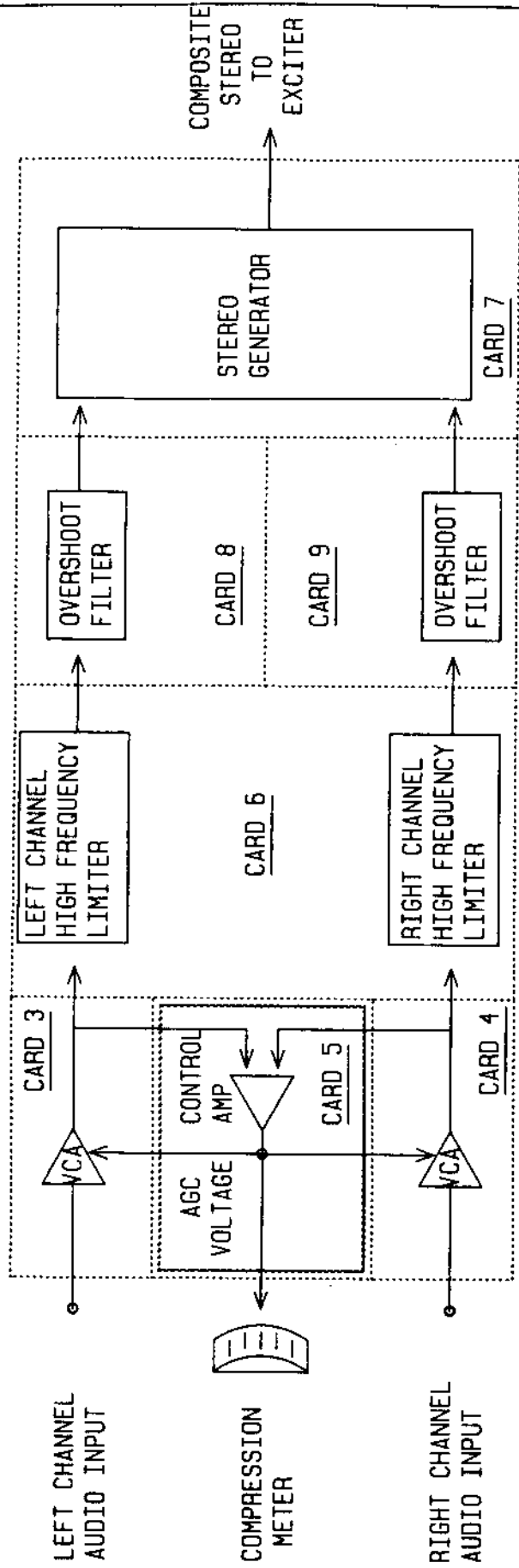

\* OPTIMOD 8100 IS A REGISTERED TRADEMARK OF ORBAN ASSOCIATES INC., SAN FRANCISCO, CA.

GENTNER

ELECTRONICS CORPORATION

BLOCK DIAGRAM  
ORBAN OPTIMOD 8100 \*

DRAWING #: 87002	REVISION: A
DRAWN BY:	DATE:
CHECKED BY: <i>[Signature]</i>	DATE: 3/11/57

---

## Index

---

### A

Adapt to 240 VAC, 2-7  
 Additional Output, 2-10  
 Adjusting the Gain of the Bypass Mode, 2-32  
 Adjustment of the Optimod 8100 (FM Applications),  
 2-24 to 2-27  
 Adjustment of the PRISM II FM, 2-12 to 2-16, 2-18  
 to 2-23  
 Adjustment of the RCF-1 Replacement Card Five, 4-  
 4 to 4-7  
 Amplifiers, Replacement Device Type Nos., 2-28  
 PRISM II FM Circuit Board Location Diagram, B-1  
 PRISM II FM Simplified Functional Block Diagram,  
 B-1  
 Audio Processor Bands  
   Troubleshooting, 3-1

### B

Balanced Output, 2-10  
 Bass Band, 4-7 to 4-8  
 Bass Boost, 4-4 to 4-6, 4-8, 4-10  
 Bass Control Voltage, 4-7 to 4-8  
 Bass Coupling Control, 2-24 to 2-25  
 Bass Follow Main, 4-9 to 4-10  
 Bass Follow Master LED, 4-4  
 Bass PARC Module, 4-5, 4-7  
 Block Diagrams, B-1  
 Bridging, 2-1, 2-9  
 Bridging Input, 2-9  
 Broadband Sample, 2-15, 2-17, 3-2  
 Buffer Active, 2-5  
 Buffer Full, 2-5  
 Buffer, Safety  
   see Safety Buffer  
 Bypass Gain Control, 2-6, 3-2  
 Bypass Mode, 2-6 to 2-7, 2-38  
 Bypass Mode Operation, 2-31  
   Adjusting the Gain of, 2-32

### C

Caution  
   Spectral Mix Adjustment, 2-17  
 Change the Character of the PRISM II FM, 2-36  
 Charge Rate of Timing Capacitors, 2-13  
 Circuit Board Location Diagram, PRISM II FM, B-1  
 Clipping, 2-10, 2-17  
   see also Composite Clipper  
   Optimod 8100, 2-24  
   RCF-1, 4-4 to 4-6, 4-8 to 4-10  
 Compact Disk Player  
   Adjusting Mix Levels, 2-17  
 Composite Clippers, 2-23, 2-32 to 2-34  
 Compress LED, 2-5  
 Compression Meter, 4-8  
 Connections  
   Rear Panel, 2-7  
 Controls  
   see also Front Panel Controls  
   RCF-1 Replacement Card Five, 4-4 to 4-5  
 Coupling Action LEDs, 4-4  
 Crossover Buildup, 2-18  
 Crossover Frequencies, 1-2  
 Customer Support, 3-3, 4-9 to 4-10  
 CX-2 Control Board Schematic, B-1

### D

DB-2 Display Board Schematic, B-1  
 Density Control, 2-5 to 2-6, 2-36  
   for Radio Applications, 2-21 to 2-22  
   for Television Applications, 2-22 to 2-23  
 Description of the PRISM II FM, 2-1  
 Differential Mode, 2-9  
 Dimensions, 1-3  
 Discharge Rate of Timing Capacitors, 2-13

### E

Echo Devices, 2-8

Enabling the Phase Rotator, 2-11

Equipment

with the RCF-1, 4-1

Establishing the L-R Channel Null, 2-18 to 2-19, 2-21

Evaluation Methods, PRISM II FM with Optimod,  
2-30 to 2-31

Exciters, 2-32

with the RCF-1, 4-2

Expand LED, 2-5

## F

Female Listeners

Adjusting Mix Levels, 2-16

FM Broadcast Configurations, 2-1 to 2-2

FM Equipment, 2-32, 2-34

Composite Clippers, 2-32 to 2-34

Exciters, 2-32

FP-1 Filter and Protection Board Schematic, B-1

Frequencies, Crossover

see Crossover Frequencies

Front Panel Controls, 2-6

Bypass Gain, 2-6 to 2-7

Bypass Mode, 2-6 to 2-7

Density, 2-5 to 2-6

Gate, 2-7, 2-14

High, 2-6

Input Gain, 2-6

Low, 2-6

Mid, 2-6

Mix Level, 2-14 to 2-16, 2-18 to 2-19, 2-21

Mix Levels, 2-6, 2-17

Output Gain, 2-6

Pink Noise, 2-6, 2-15

Presence Band, 2-6

Front Panel Indicators, 2-4

Buffer Active, 2-5

Buffer Full, 2-5

Compress LED, 2-5

Expand LED, 2-5

-15V LED, 2-5

Peak LED, 2-5

+ 15V LED, 2-5

Quiescent LED, 2-4

Safety Buffer, 2-4 to 2-5

Signal LED, 2-4

Functional Block Diagram, PRISM II FM, Simplified,  
B-1

## G

Gate, 2-4, 2-25, 4-5

Gate Control, 2-4, 2-6 to 2-7, 2-14 to 2-15

Optimod 8100, 2-24

Gate Threshold Control, 2-14, 2-25

Generator

see Pink Noise

Gentner Customer Support, 3-3, 4-9 to 4-10

Gentner Replacement Card Five

see RCF-1 Replacement Card Five

## H

Harmonic Distortion, 1-3

Heavy Processing

see Robust Processing

Help

Customer Support Number, 3-3, 4-9 to 4-10

HF Limiting Control

Card 6, 4-6

Optimod 8100, 2-24

RCF-1, 4-5

High Band, 2-13 to 2-14, 2-19

Control, 2-6, 2-16 to 2-17, 4-7, A-1

see also Mix Level Controls

Highpass Filter, 2-27

## I

IBC-1

see Interband Coupling Module

IC

Part Numbers, 2-28

Replacement Device Types, 2-28

Impedance, Input

see Input Impedance

Impedance, Output

see Output Impedance

Induction Field, 2-10

Input Gain, 2-9, 2-21

Control, 2-6, 2-13, 2-19

Optimod, 2-21, 2-26

Input Gain Control

in Troubleshooting, 3-2

Input Impedance, 1-2, 2-1  
 Input Level, 1-2, 2-5, 2-9  
 Input Stage, 2-9  
 Installation of the RCF-1 Replacement Card Five, 4-1 to 4-2, 4-4  
 Interband Coupling, 4-4 to 4-5, 4-8, 4-10  
 Interband Coupling Module, 4-4 to 4-5, 4-8, 4-10  
 Internal Adjustments, 2-36

## L

L-R Channel Null, 2-18 to 2-19, 2-21  
 LED  
   see Front Panel Indicators  
 Level, Input  
   see Input Level  
 Level, Output  
   see Output Level  
 Levels, Mixed  
   see Mixed Levels  
 Light Processing, 2-24  
 Limiter Board Amplifiers, Replacement Device Type Nos., 2-28  
 Limiting Meter, 4-8  
 Low Band, 2-13, 2-19 to 2-20  
   Control, 2-6, A-1  
   see also Mix Level Controls

## M

M-102 Digitally Controlled Audio Processor Schematic, B-1  
 M-102 Processor, 2-2  
   Troubleshooting, 3-2  
 Main Follow Bass, 4-9 to 4-10  
 Master Band, 4-7 to 4-8  
 Master Control Voltage, 4-8, 4-10  
 Master Follow Bass LED, 4-4  
 Master PARC Module, 4-5, 4-7 to 4-8  
 Master Perceptual Attack and Recovery Computer  
   see Master PARC Module  
 MB-2 Motherboard Schematic, B-1  
 Mid Band, 2-13  
   Control, 2-6, A-1  
   see also Mix Level Controls  
 -15V LED, 2-5, 3-1

Mix Level Controls, 2-6, 2-13, 2-15 to 2-21  
   Adjusting for CDs, 2-17  
   Adjusting for Female Listeners, 2-16  
   see also High Band  
   in Troubleshooting, 3-2  
   see also Low Band  
   see also Mid Band  
   see also Presence Band  
   Setting, 2-14  
   Settings, A-1  
   with the Orban 8100, 2-23  
   with the RCF-1, 4-7  
 Moderate Processing, 2-24  
 Music and Voice Processing Systems, Separate, 2-37 to 2-38

## N

No Output, Troubleshooting, 3-2  
 Noise Reduction, 2-7 to 2-8, 2-13, 2-21

## O

Operate Mode, 4-10  
   see also Proof/Operate Switch  
 Operation with the Orban Optimod 8000 (FM Applications), 2-27 to 2-31  
 Optimod 8000  
   see Orban Optimod 8000  
 Optimod 8100  
   see Orban Optimod 8100  
 Orban Card #5  
   see Orban Optimod 8100  
 Orban Optimod 8000, 2-27 to 2-28  
   Evaluation Methods, 2-30 to 2-31  
   Mix Level Settings, A-1  
   Rechipping, 2-28 to 2-30  
 Orban Optimod 8100  
   Adjusting for L-R Channel Null, 2-21  
   Adjusting VCA Action, 2-21  
   Adjustment, 2-24 to 2-27  
   Evaluation Methods, 2-30 to 2-31  
   Input Gain, 2-26  
   Mix Level Settings, A-1  
   Recommended Mix Levels, 2-17  
   Removing the Phase Rotators, 2-26 to 2-27

Settings of the Gate Threshold, Bass Coupling, Release Time Controls, 2-25  
 Signal LED, 2-4, 2-7, 2-14  
 Signal to Noise Ratio, 1-3  
 Sine Wave Tones, 2-17 to 2-18  
 Single-ended Outputs, 2-10  
 Specifications, Technical  
   see Technical Specifications  
 Spectral Mix, 2-14, 2-18, 4-7  
   Adjustment Caution, 2-17  
   Adjustment with the Orban 8100, 2-23  
 Stereo Strapping, 2-7  
 Strapping, Stereo  
   see Stereo Strapping  
 Sum Less Than 20, 2-17

## T

Technical Specifications, 1-2  
   Crossover Frequencies, 1-2  
   Dimensions, 1-3  
   Harmonic Distortion, 1-3  
   Input Impedance, 1-2  
   Input Level, 1-2  
   Output Impedance, 1-2  
   Output Level, 1-3  
   Signal to Noise Ratio, 1-3  
   Weight, 1-3  
 Telephone Lines, 2-10, 2-27, 4-2  
 Television Applications, Setting Density Control, 2-22 to 2-23  
 Test Equipment, 2-12  
 Test Points, 2-10, 2-15, 2-17 to 2-18  
   Troubleshooting, 3-1 to 3-2  
 Testing Adjustment, 2-23  
 Theory of Operation  
   PRISM II FM, 2-34 to 2-36  
   RCF-1 Replacement Card Five, 4-7 to 4-9  
 30 Hz Highpass Filter, 2-27  
 Timing Capacitors, 2-13  
 Troubleshooting  
   Prism II FM, 3-1 to 3-4  
   RCF-1 Replacement Card Five, 4-9 to 4-10  
 240 VAC, 2-7

## U

Unit-to-Unit Tracking, 2-19  
 Using the PRISM II FM with FM Equipment, 2-32 to 2-34

## V

Variable Gain, 2-26  
 Ventilation, 2-10  
 Voice and Music Processing Systems, Separate, 2-37 to 2-38

## W

Warranty, 1-4  
 Weight, 1-3