



MX-5050BII
SERIES PROFESSIONAL RECORDERS
INSTRUCTION MANUAL

CAUTION

To prevent fire or shock hazard :

Do not expose this appliance to rain or moisture.

Do not remove cover.

No user-serviceable parts inside.

Refer servicing to qualified service personnel.

PLEASE READ THROUGH SAFETY INSTRUCTIONS
ON THE NEXT PAGE.

SAFETY INSTRUCTIONS

1. Read Instructions — All the safety and operating instructions should be read before the appliance is operated.
2. Retain Instructions — The safety and operating instructions should be retained for future reference.
3. Heed Warnings — All warnings on the appliance and in the operating instructions should be adhered to.
4. Follow Instructions — All instructions should be followed.
5. Water and Moisture — The appliance should not be used near water - for example, near a bathtub, washbasin, kitchen sink, laundrytub, in a wet basement, or near a swimming pool, etc.
6. Carts and Stands — The appliance should be used only with a cart or stand that is recommended by the manufacturer.
7. Ventilation — The appliance should be situated so that its location or position does not interfere with its proper ventilation.
For example, the appliance should not be situated on a bed, sofa, rug, or similar surface that may block the ventilation operatings; or, placed in a built-in installation, such as a bookcase or cabinet that may impede the flow of air through the ventilation openings.
8. Heat — The appliance should be situated away from near sources such as radiators, heat registers, stoves, or other appliances (including amplifiers) that produce heat.
9. Power Sources — The appliance should be connected to a power supply only of the type described in the operating instructions or as marked on the appliance.
10. Grounding or Polarization — Precautions should be taken so that the grounding or polarization means of an appliance are not defeated.
11. Power-Cord Protection — Power-supply cords should be routed so that they are not likely to be walked on or pinched by items placed upon or against them, paying particular attention to cords at plugs. Convenience receptacles, and the point where they exit from the appliance.
12. Cleaning — The appliance should be cleaned only as recommended by the manufacturer.
13. Nonuse Periods — The power cord of the appliance should be unplugged from the outlet when left unused for a long period of time.
14. Object and Liquid Entry — Care should be taken so that

objects do not fall into and liquids are not spilled into the enclosure through openings.

15. Damage Requiring Service — The appliance should be serviced by qualified service personnel when:
 - A. The power-supply cord or the plug has been damaged; or
 - B. Objects have fallen, or liquid has been spilled into the appliance; or
 - C. The appliance has been exposed to rain; or
 - D. The appliance does not appear to operate normally or exhibits marked change in performance; or
 - E. The appliance has been dropped, or the enclosure damaged.
16. Servicing — The user should not attempt to service the appliance beyond that described in the operating instructions. All other servicing should be referred to qualified service personnel.

WARNING

This equipment generates, uses, and can radiate radio frequency energy and if not installed and used in accordance with the instructions manual, may cause interference to radio communications. It has been tested and found to comply with the limits for a Class A computing device pursuant to Subpart J of Part 15 of FCC Rules, which are designed to provide reasonable protection against such interference when operated in a commercial environment. Operation of this equipment in a residential area is likely to cause interference in which case the user at this own expense will be required to take whatever measures may be required to correct the interference.

COMMUNICATION WITH OTARI FOR SERVICE INFORMATION AND PARTS

The OTARI PRODUCTS are manufactured under strict quality control and each unit is carefully tested and inspected prior to shipment from our factory.

If, however, some adjustments or technical support become necessary, replacement parts are required, or technical questions arise, please contact your nearest Otari dealer or write to:

OTARI ELECTRIC CO., LTD.

4-29-18, Minami Ogikubo,
Suginami-ku, Tokyo, 167, Japan
Phone: (03) 333-9631
Telex: J26604 OTRDENKI
Fax : (03) 331-5802

OTARI CORPORATION

2 Davis Drive, Belmont,
California 94002, U.S.A.
Phone: ~~(415) 592-8311~~
Telex: 25 9103764890 *341-5900(650)*
Fax : (415) 591-3377

OTARI ELECTRIC DEUTSCHLAND GmbH.

Rudolf-Diesel-Str. 12
D-4005 Meerbusch 2 (Osterath)
F.R. Germany
Phone: 02159-50861 ~ 3
Telex: 8531638 OTEL D
Fax : 02159-1778

OTARI SINGAPORE PTE., LTD.

625 Aljunied Road #07-05
Aljunied Industrial Complex,
Singapore 1438
Phone: 743-7711
Telex: 87 36935 RS36935 OTARI
Fax : (743) 6430

OTARI ELECTRIC (UK) LTD.

22 Church Street Slough Berkshire SL1 1PT
United Kingdom
Phone: SLOUGH (0753) 822381
Telex: 849453 OTARI G
Fax : (0753) 823707

Another part of Otari's continuous technical support program for our products, is the continuous revision of manuals as the equipment is improved or modified.

In order for you to receive our information and service applicable to your requirements, and for the technical support to function properly, please include the following information, most of which can be obtained from the name plate on the equipment in all correspondences.

1. Model Number
2. Serial Number
3. Date of purchase
4. Name and address of dealer from whom machine was purchased
5. Power requirements (voltage and frequency) of the machine
6. Manual number to which you are referring

TABLE OF CONTENTS

PAGE	SECTION	TOPIC
	I	GENERAL INFORMATION
1-1	1.1	System Description
1-2	1.1.1	Tape Transport
1-3	1.1.2	Record/Reproduce Electronics
1-3	1.1.3	Head Assemblies
1-4	1.2	Standard Accessories
1-4	1.3	Optional Accessories
1-5	1.4	Service and Replacement Parts
1-5	1.5	Specifications
	II	INSTALLATION
2-1	2.1	Unpacking and Inspection
2-1	2.2	Location and Environment
2-2	2.3	Dimensions
2-2	2.4	Standard Switch Position on Shipment
2-4	2.5	Power and Signal Connections
2-7	2.5.1	AC Power Connections
2-8	2.5.2	Signal Connections
	III	OPERATION
3-1	3.1	Controls and Indicators
3-9	3.2	Operating Information
3-9	3.2.1	Use of the Reel Hold Down Knobs
3-10	3.2.2	Pre-operating Procedure
3-11	3.2.3	Reproduction
3-12	3.2.4	Normal Recording
3-13	3.2.5	Recording with Selective Production
3-14	3.2.6	Fast Winding
3-14	3.2.7	Editing and Splicing Tape
	IV	PREVENTIVE MAINTENANCE AND ADJUSTMENTS
4-1	4.1	Test and Maintenance Equipment Requirements
4-2	4.2	Preventive Maintenance

PAGE	SECTION	TOPIC
4-2	4.2.1	Cleaning
4-3	4.2.2	Demagnetizing
4-4	4.2.3	Lubrication
4-5	4.3	Electronic Trimming
4-5	4.3.1	Record Bias Adjustment
4-5	4.3.2	Record Level Adjustment
4-6	4.3.3	Record Equalization Adjustment
	V	AMPLIFIER ADJUSTMENTS
5-1	5.1	Access to the Amplifier
5-1	5.2	Amplifier P.C.B. Assembly layout
5-6	5.3	Block Diagram and Circuit Description
5-6	5.3.1	Reproduce Circuit
5-6	5.3.2	Record Circuit
5-9	5.4	Transport Control Timing Chart
5-9	5.5	Amplifier Adjustment
5-9	5.5.1	Test Tape Selection
5-10	5.5.2	Head Alignment
5-12	5.5.3	Reproduce Equalization Adjustment
5-13	5.5.4	Bias Adjustment
5-15	5.5.5	Record Level, Monitor Level Adjustment
5-15	5.5.6	Peak Indicator Trigger Level Adjustment
	VI	TAPE TRANSPORT MAINTENANCE AND REPLACEMENT PROCEDURE
6-1	6.1	Transport Access
6-2	6.2	Brake Adjustment
6-4	6.3	Capstan Pinch Roller Pressure Adjustment
6-6	6.4	Speed Conversion and Speed Adjustment
6-7	6.5	Reel Motor Assembly Replacement
6-7	6.5.1	Reel Table Height Adjustment and Replacement
6-7	6.5.2	Reel Motor Replacement
6-8	6.5.3	Brake Band and Solenoid Replacement
6-9	6.6	Power Transformer Replacement
6-9	6.7	Capstan Motor Replacement

PAGE	SECTION	TOPIC
6-10	6.8	Pinch Roller Replacement
6-11	6.9	Head Assembly Replacement
6-11	6.9.1	Description
6-12	6.9.2	Head Stack Replacement
	VII	PERFORMANCE TESTING
7-1	7.1	General Notice
7-1	7.2	Test Tapes
7-2	7.3	Test Conditions
7-2	7.4	Performance Tests
7-3	7.4.1	Overall Signal-Noise Ratio
7-4	7.4.2	Overall Distortion Test
7-5	7.4.3	Crosstalk Test
7-6	7.4.4	Erasure Test
7-7	7.4.5	Tape Speed Measurement
7-8	7.4.6	Flutter and Wow Test
	VIII	P.C.B. ASSEMBLIES AND PARTS LISTS
	IX	EXPLODED VIEW DRAWINGS AND PARTS LISTS
	X	CIRCUIT DIAGRAMS

SECTION I. GENERAL INFORMATION

The MX-5050BII Series Recorders are professional quality two-speed audio tape recorder/reproducers designed for optimum performance and long life.

The MX-5050BII units use 1/4-inch tape and are available in 4 different models. The different models, and their application, are determined by the head format.

Table 1-1

Model	Head Format	Speed	Tape
BII-2	2-track, 2-channel	*15 and 7-1/2 IPS	1/4 inch
BII-4	4-track, 2-channel		
BII-F	Full track, Mono		
BII-2E	2-track, 2-channel DIN		

* The MX-5050BII is factory set to operate at tape speeds of 15 and 7-1/2 ips. By users conversion the unit can be reset to operate at 7-1/2 and 3-3/4 ips. Refer to page 5-1.

1.1 SYSTEM DESCRIPTION

Among the many professional features of the MX-5050BII Series are: selective reproduction, motion sensing, an edit control that permits spilling, an adjustable cueing control for audible monitoring in the fast-forward and rewind modes, a built-in two frequency low distortion test and cue-tone oscillator, a computerized elapsed time indicator with a digital LED display, front adjustable record bias, equalization, and level controls, active balanced input and output circuits, a reference flux level indicator on the front amplifier panel, a standard reference level output switch, separate line and microphone input level controls for each channel, switches for recording levels, equalization, microphone, and output level attenuators, play-back equalization pots for each speed, a memory stop for automatically stopping the tape in the rewind mode at a predetermined position, ceramic tape guides, big head housing, lower transport noise, and improved specifications for distortion, erase effect, and signal and noise ratio.

1.1.1 TAPE TRANSPORT

All components of the tape transport system are mounted on a rigid aluminum frame for stability. The transport design incorporates two 6-pole induction motors for the reels and a 3-speed DC servo motor (Direct drive) for the capstan.

Speed selection is made by a front panel push-button switch which also switches the equalizer.

The transport accommodates tape reels of 10-1/2 inches, 7 inches, and 5 inches in diameter with NAB or EIA hub configurations. A solenoid-actuated tape lifter lifts the tape away from the heads in the fast forward and rewind modes, in addition to the stop mode, to increase head and tape life.

In addition to the editing controls, a tape-splicing block (Fig. 3-3) mounted on the head cover holds the tape for ease of editing.

Momentary contact push-button switches on the transport are used to select operational modes: record, play, stop, rewind, and fast forward. These modes may be controlled from a remote location by means of an optional remote control unit (page 1-5).

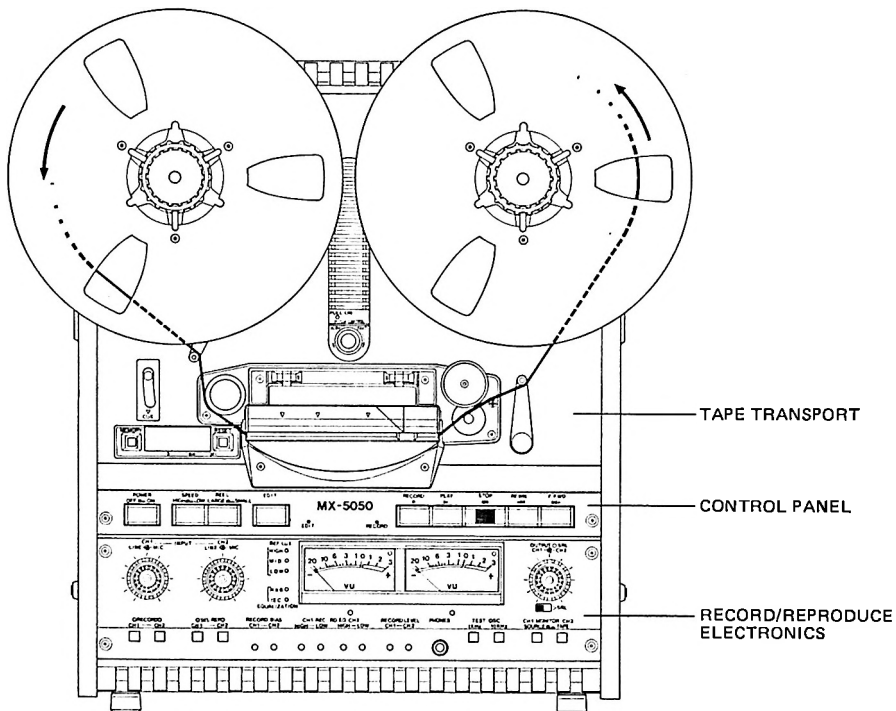

Fig. 1-1 MX-5050BII Major Components

1.1.2 RECORD/REPRODUCE ELECTRONICS

FEATURES

- (1) The RECORD/REPRODUCE amplifier unit is connected to the transport unit only by the connectors and therefore can be easily removed for ease in servicing.
- (2) This machine contains a SEL. REP. function for overdubbing: for example, SOUND WITH SOUND, SOUND ON SOUND, carried out by the PUNCH-IN and PUNCH-OUT functions of the transport control.
- (3) This machine provides both NAB and IEC equalizers, switchable on the rear panel. However, when the equalizer position is changed, fine tuning the record and reproduce equalizer adjustment controller is necessary.
- (4) In order to give optimum performance for different types of recording tapes, record bias, level, and equalization controls on the front panel can be adjusted to meet any requirements.
- (5) To improve the signal to noise ratio and increase the head room, the record/reproduce electronics have been designed with a high-fidelity amplifier.

1.1.3 HEAD ASSEMBLIES

As viewed from the front of the recorder, the configuration of the head assembly of each model MX-5050BII is shown in Table 1-2.

Table 1-2 Head Assembly Configuration

Model No.	Head Structure				Record Head
	H1 Erase	H2 Playback	H3 Record	H4 Playback	
MX-5050BII-2	2T, 2CH	4T, 2CH	2T, 2CH	2T, 2CH	2T, 2CH Stereo
MX-5050BII-4	4T, 2CH	2T, 2CH	4T, 2CH	4T, 2CH	4T, 2CH Stereo
MX-5050BII-F	FT, MONO	2T, 2CH	FT, MONO	FT, MONO	FT Monoaural
MX-5050BII-2E	2T, 2CH DIN	4T, 2CH	2T, 2CH DIN	2T, 2CH DIN	2T, 2CH Stereo

NOTE: The head assemblies of these models contain two playback head stacks. A head change-over switch located in the head assembly permits selection of either head stack.

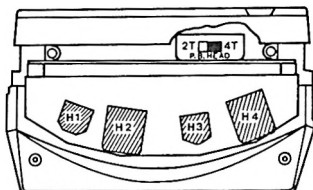

Fig. 1-2 Head Arrangement

1.2 STANDARD ACCESSORIES

The MX-5050BII is supplied with the standard accessories listed below.

STANDARD ACCESSORIES (*ZA-12W)

1.	NAB Hub Reel Hold Down Knob	KW0HO	2 pcs.
2.	NAB Empty Reel 10-1/2 inch	ZA-51A	1 pc.
3.	Reel Adjusting Disc (Shim)**	KW0C005	2 pcs.
4.	Instruction Manual	OS3-038	1 pc.
5.	Power Cord	PZ9D003	1 pc.

* This part number includes all parts described in numbers 1 through 5.

** The reel-adjusting disc (shim) is placed between a metal reel and the turntable to compensate for the difference in thickness between metal reels and plastic reels.

1.3 OPTIONAL ACCESSORIES

Optional accessories available are listed below.

OPTIONAL ACCESSORIES

- | | |
|--------------------------------------|--------|
| 1. Remote Control Unit | CB-102 |
| 2. Cleaning Kit | ZA-51B |
| 3. Balanced Input Transformer Ass'y | ZA-53T |
| 4. Balanced Output Transformer Ass'y | ZA-53S |

1.4 SERVICE AND REPLACEMENT PARTS

For service and replacement parts, or for technical support, please contact your nearest service center, Otari dealer, or write directly to Otari. (See page iii for complete addresses.)

1.5 SPECIFICATIONS

The specifications of the MX-5050BII Series are as listed in Table 1-3.

NOTE: Specifications are based on tape speeds of 7-1/2 and 15 ips. Specifications, although obtainable when serviced by qualified service personnel, are not guaranteed when using lower tape speeds.

Table 1-3 Specifications of the MX-5050B Series

Tape Width and Tracks	<p>1/4 inch (6.3 mm) tape:</p> <p>2 tracks (0.079 in. or 2.0 mm track width)</p> <p>4 tracks (0.040 in. or 1.0 mm track width)</p> <p>Full tracks (0.24 in. or 6.1 mm track width)</p>
Tape Speeds	<p>7-1/2 and 15 ips (19 and 38 cm/sec) or 3-3/4 and 7-1/2 ips (9.5 and 19 cm/sec)</p> <p>Maximum deviation: $\pm 0.2\%$ measured with 1.5 mil (0.038 mm) tape.</p>
Reel Sizes	<p>7 inch or 10-1/2 inch plastic or metal, EIA or NAB.</p>

Heads	<p>Model MX-5050BII-2: Half-track configuration</p> <p>Model MX-5050BII-4: Quarter-track configuration</p> <p>Model MX-5050BII-F: Full-track configuration</p> <p>Model MX-5050BII-2E: Half-track configuration</p> <p>Four head stacks:</p> <p>MX-5050BII-2: 2T erase, 4T reproduce, 2T record, 2T reproduce.</p> <p>MX-5050BII-4: 4T erase, 2T reproduce, 4T record, 4T reproduce.</p> <p>MX-5050BII-F: FT erase, 2T reproduce, FT record, FT reproduce.</p> <p>MX-5050BII-2E: 2T DIN erase, 4T reproduce, 2T DIN record, 2T DIN reproduce.</p>
Motors: Capstan	DC servo controlled motor. (Pitch control limits $\pm 7\%$)
Reels	Two induction torque motors.
Operating Position	Vertical or horizontal.
Power Requirements	50/60 Hz, 100/117/220/240 V $\pm 10\%$ Single phase AC, 100 W
Operating Environment	40° to 104°F (5° to 40°C) 20 to 80 % RH
Storage Environment	-5° to 113°F (-20° to 45°C)
Dimensions and Weight	<p>Height 527 mm (20.7 inch)</p> <p>Width 430 mm (16.9 inch)</p> <p>Depth 225 mm (8.8 inch)</p> <p>24 kgs (53 lbs.)</p>
Mounting	Dark grey leather-finished cabinet.
Standard Accessories	One empty 10-1/2 inch NAB reel, two NAB reel hold down knobs, two NAB reel-adjusting discs (shims), and one instruction manual, one power cord.

Remote Control Unit	An optional remote control unit is used to control the record, play, stop, rewind, and fast forward modes.
Connectors	Line input, line output, and microphone, standard three-pin XLR.
Inputs: Line	Minimum -15 dBm, active balanced 10 k ohms. (Floating type). Minimum -15 dBm, balanced 10 kohms with optional transformer.
Microphone	Minimum -70 dBm, active balanced, adaptable microphone's impedance: 150 to 10 k ohms. The microphone attenuator switch may be set to the 0 dB, -20 dB, or Off position depending on the circumstances.
Outputs: Line	Level: +4 dBm or -10 dBm, rear panel switch selectable. Active balanced (Floating type), Source impedance: 5 ohms. Load impedance: More than 600 ohms. Maximum line output: +27 dBs with a 600 ohm load.
Headphone	Level: -24 dBm with an 8 ohm load. Load impedance: 8 ohms or greater.
Equalization	NAB or IEC for 3-3/4, 7-1/2, and 15 ips. Switchable on the rear panel, but calibration is necessary.
Frequency Response	15 ips: 30 Hz to 20 kHz \pm 2 dB 7-1/2 ips: 20 Hz to 18 kHz \pm 2 dB 3-3/4 ips: 20 Hz to 10 kHz \pm 2 dB Specifications refer to a 1 kHz reference when recorded on 3M 226.
Signal to Noise Ratio	Over-all measured at the level of 520 nWb/m.

NAB Equalization

Tape Speed	2 Track		4 Track		Full Track	
	Weighted	Unweighted	Weighted	Unweighted	Weighted	Unweighted
15 ips	66 dB	64 dB	62 dB	60 dB	68 dB	66 dB
7-1/2 ips	68 dB	66 dB	63 dB	61 dB	68 dB	66 dB
3-3/4 ips	66 dB	64 dB	62 dB	60 dB	66 dB	64 dB

IEC Equalization

Tape Speed	2 Track		4 Track		Full Track	
	Weighted	Unweighted	Weighted	Unweighted	Weighted	Unweighted
15 ips	66 dB	62 dB	62 dB	58 dB	62 dB	60 dB
7-1/2 ips	64 dB	62 dB	62 dB	58 dB	62 dB	60 dB
3-3/4 ips	64 dB	62 dB	62 dB	58 dB	62 dB	60 dB

Crosstalk

With a 1 kHz signal on adjacent tracks:

2 tracks: greater than 55 dB

4 tracks: greater than 55 dB

Wow and Flutter

(NAB weighted):

Tape Speed	
15 ips	less than 0.06 %
7-1/2 ips	less than 0.08 %
3-3/4 ips	less than 0.12 %

Distortion

Less than 0.5% at 1 kHz at 250 nWb/m.

Erase Efficiency

Greater than 75 dB.

Test Oscillator Frequency	Nominal 1 kHz and 10 kHz
Bias and Erase Frequency	133 kHz
Peak Indicator	Trigger level: 1040 nWb/m (15 dB above Ampex operating level) recorded flux level.
Record Level (SRL)	3-position switchable on the rear panel.

Position	Flux	Relative Level	Test Tape	Recording tape to be used
Low	185 nWb/m*	0 dB	Ampex Operating Level	Scotch 177, Ampex 641
Medium	250 nWb/m*	+2.6 dB	MRL NAB Reference Flux	Scotch 206, 207, 226, 250 Ampex 406, 407, 456
High	320 nWb/m**	+3.8 dB	BASF or MRL IEC Standard	IEC Equalization

* Short circuit flux
** Open circuit flux

- NOTES: 1. Signal to noise ratio is measured with respect to a recorded level of 520 nWb/m to biased tape noise when using Scotch 226 magnetic tape.
Unweighted: Using a 30 to 18 kHz RC filter to attenuate noise outside the audio spectrum.
Weighted : Using an NAB or ASA "A" weighting filter and a 1 kHz reference.
2. Otari reserves the right to change specifications without notice and/or obligation.
3. IN CASE OF DIN STEREO VERSION (MX-5050BII-2E), 3-POSITIONS ARE SET AS FOLLOWING.
- | | |
|--------|-----------|
| Low | 250 nWb/m |
| Medium | 320 nWb/m |
| High | 520 nWb/m |

SECTION II. INSTALLATION

This section of the manual provides information on unpacking and inspection, location and environment, and power and signal connections.

2.1 UNPACKING AND INSPECTION

The MX-5050BII Series system is shipped from the factory in a single cardboard packing case. Upon receipt, examine the case for any signs of damage. Unpack the equipment and inspect for any signs of damage. Use great care when unpacking the equipment and removing packing materials to prevent damage to critical components such as the capstan, head assembly, and tension arms.

Referring to the lists in Secs. 1.2 and 1.3 (as applicable), verify that all items have been received. Report any shortage or damage to the carrier and your local Otari dealer. Save the packing case for possible reshipment. Other packaging may cause damage during transportation and will void the warranty.

Please refer to the illustration which is attached to flap of the packing box regarding the repacking method.

2.2 LOCATION AND ENVIRONMENT

The area chosen for operation should be adequately ventilated and dust free. Since recording is by an electromagnetic process, it is possible that strong electromagnetic fields may affect the system adversely. Common sources of interference are fluctuating loads on nearby high-voltage lines, heavy duty transformers, and transmitting equipment.

It is recommended that the equipment be used in an environment where the surrounding temperature does not exceed limits of 40° to 104°F (5° to 40°C), with the relative humidity between 20 and 80%. Allow at least a 4 inch (10 cm) clearance behind the rear-panel ventilation grill.

2.3 DIMENSIONS

Equipment dimensions of the MX-5050BII Series are shown in Fig. 2-1.

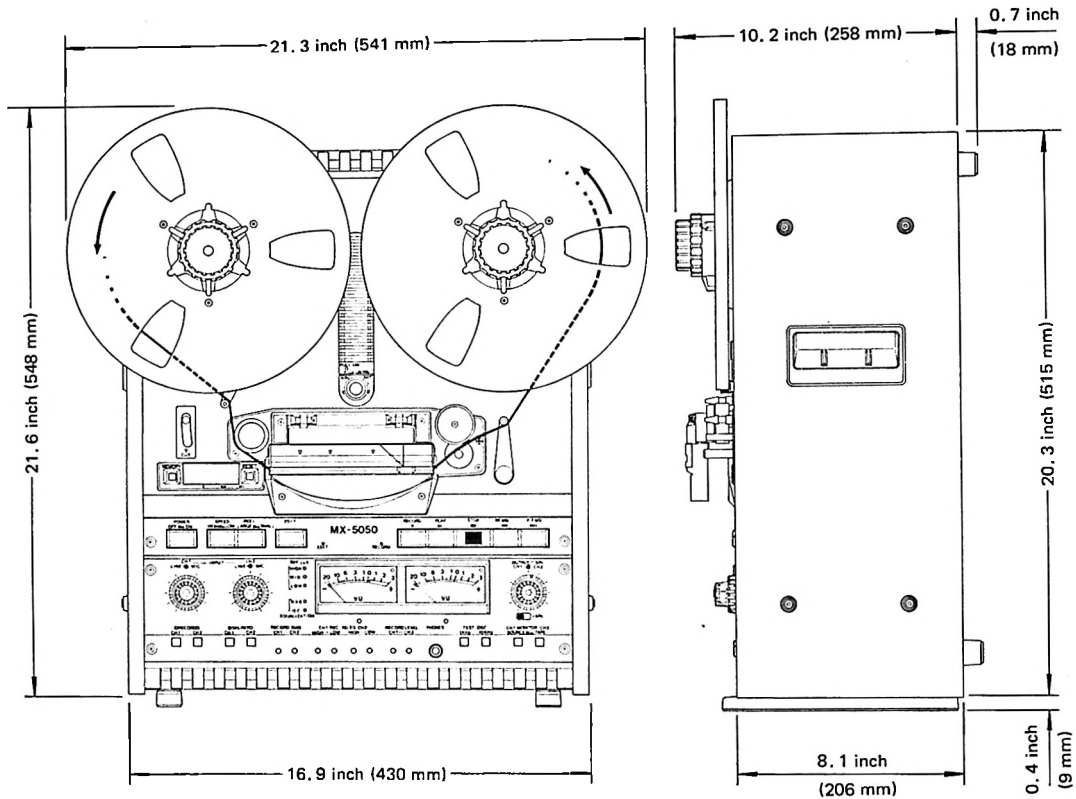

Fig. 2-1 Equipment Dimensions

2.4 STANDARD SWITCH POSITION ON SHIPMENT

Either the NAB standard or the IEC standard of equalization, recording level, etc. may be used with the Otari MX-5050BII series. These units have been provided with a slide switch on the back panel which selects one of these two standards; to change standards, merely slide the switch to the desired position.

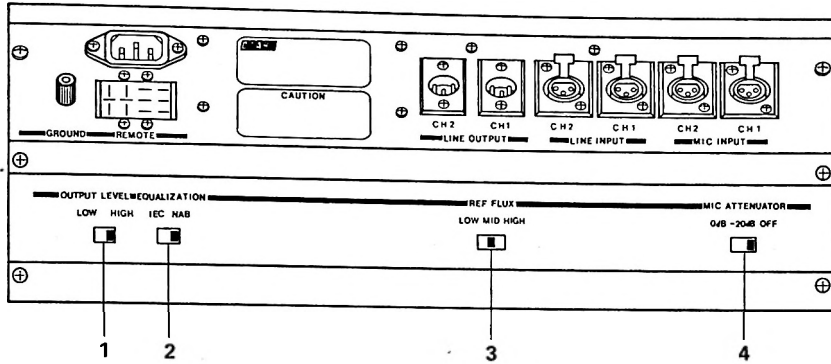

Fig. 2-2(a) Standard Switch Position on Shipment (NAB)

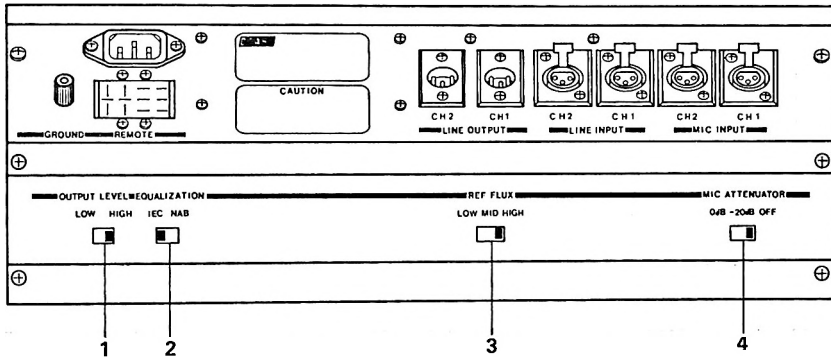

Fig. 2-2(b) Standard Switch Position on Shipment (IEC)

Table 2-1 Standard Switch Position on Shipment

Switch	Ref. No.	Type	
		NAB	IEC
OUTPUT LEVEL	1	HIGH	HIGH
EQUALIZER	2	NAB	IEC
RECORD LEVEL	3	M	H
MIC. ATT	4	OFF	OFF

2.5 POWER AND SIGNAL CONNECTION

All power and signal connections are made on the connector panel of the MX-5050BII. Table 2-2 shows the function of each connector and component on the rear panel.

Table 2-2 Rear Connector Panel

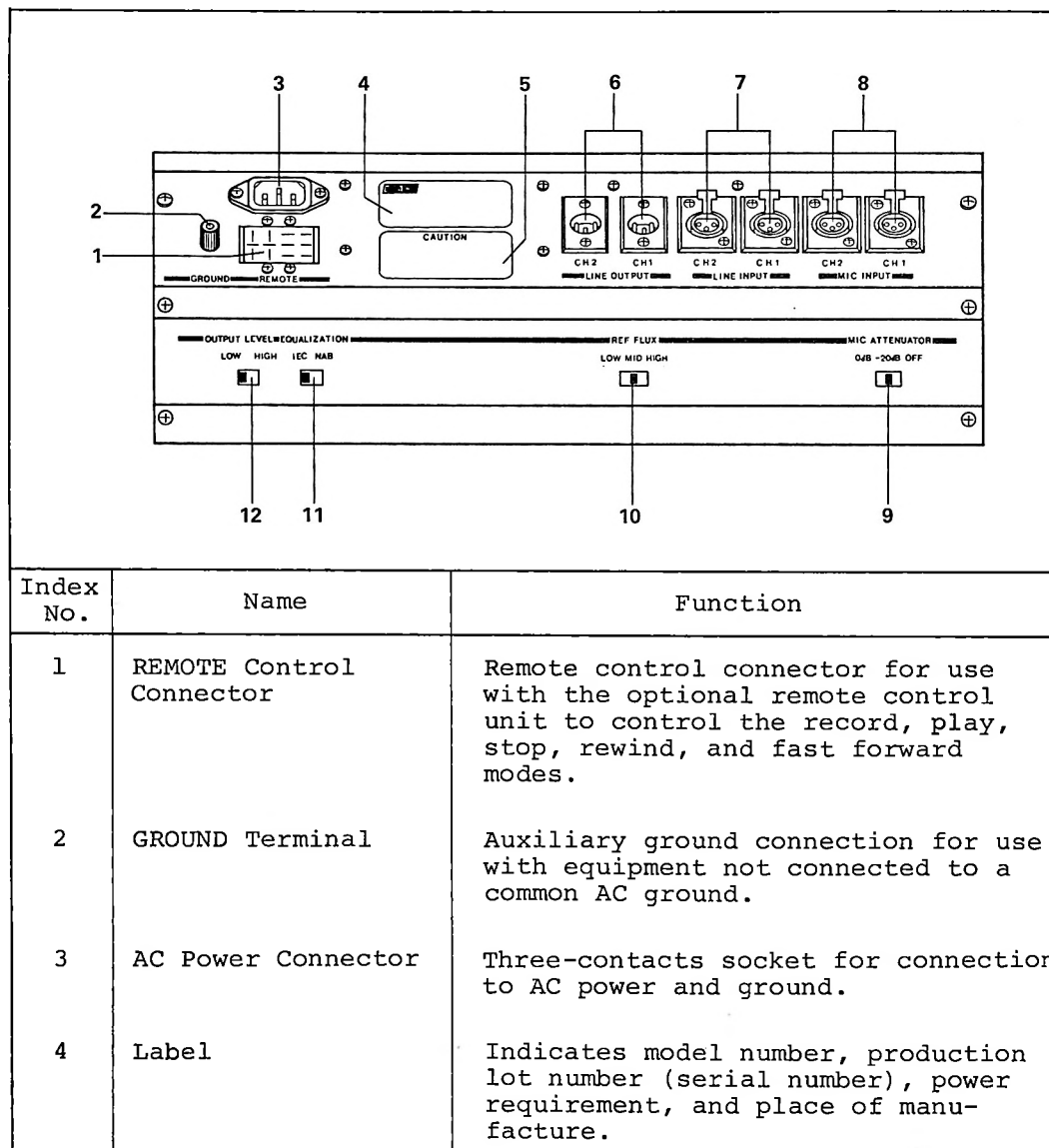

- | | | |
|---|------------------------------|--|
| 5 | CAUTION Label | Precautions for preventing fire and shock. |
| 6 | LINE OUTPUT Connector | Male XLR-type connector.
Active balanced output (Floating type).
Source impedance: 5 ohms
Load impedance: 600 ohms or greater.
Level: +4 dBm or -10 dBm at 0 VU switchable by the OUTPUT LEVEL switch. |
| 7 | LINE INPUT Connector | Female XLR-type connector.
Active balanced input (Floating type).
Input impedance: 10 kohms
Minimum input : -15 dBm
Maximum input before clipping: +30 dBm
Optional transformer balanced input.
Input impedance: 10 kohms
Minimum input : -15 dBm
Maximum input before clipping: +30 dBm |
| 8 | MICROPHONE Input Connector | Female XLR-type connector.
Active balanced input (Floating type).
Applicable microphone impedance: 150-10 kohms.
Minimum input: -70 dBm or -50 dBm switchable by means of the MIC ATTENUATOR switch. |
| 9 | MICROPHONE ATTENUATOR Switch | Used to adjust the sensitivity of the microphone amplifier in accordance with the microphone's input level. |

ATT	Minimum Input (Sensitivity)
0 dB	-70 dBm
-20dB	-50 dBm
OFF	Shorted to the ground

9 (Continued)

When a microphone is not used, this switch should be placed in the "OFF" position to avoid noise from the microphone amplifier being placed on the tape.

10 RECORD LEVEL
Selector Switch

This switch is used for setting the recording level: "High", "Medium", and "Low". Located on the Amplifier front panel are 3 LED Record Level Selector Indicator displays which indicate the position of the switch. (185/250/320)

Position	Flux	Relative Level	Test Tape	Recording tape to be used
Low	185 nWb/m*	0 dB	Ampex Operat-	Scotch 177 Ampex 641
Medium	250 nWb/m*	+2.6 dB	MRL NAB Reference Flux	Scotch 206, 207, 226, 250 Ampex 406, 407, 456
High	320 nWb/m**	+3.8 dB	BASF or MRL IEC Standard	IEC Equaliza- tion

* Short circuit flux

** Open circuit flux

RECORD LEVELS FOR DIN STEREO VERSION DIFFER FROM ABOVE. REFER TO PAGE 1-9.

11 EQUALIZER Selector
Switch

The two-position EQUALIZER selector switch is used to select either LEC or NAB equalization.

The equalizer of this unit has five settings. These have already been adjusted before shipment. These settings may be changed, but it is necessary to tune them finely.

- 1 NAB 15 ips (3180 + 50 μ sec)
- 2 NAB 7.5 ips (3180 + 50 μ sec)
- 3 IEC 15 ips (∞ + 35 μ sec)
- 4 IEC 7.5 ips (∞ + 70 μ sec)
- 5 Both NAB and IEC 3.75 ips
(3180 + 90 μ sec)

11	(Continued)	Located on the amplifier front panel are 2 LED EQ Selection Indicator displays which indicate the position of this switch (NAB or IEC).
12	LINE OUTPUT LEVEL Selector Switch	A two-position output level switch used to select either the +4 dBm or -10 dBm output standard reference level (SRL).

2.5.1 AC POWER CONNECTION

The MX-5050BII Series is factory set to operate at the line voltage and frequency indicated on the packing case and on the rear connector panel of the equipment. AC power is connected by means of a three-wire power cable which also provides a common ground connection.

If a change of line voltage and/or frequency is desired to accommodate different power requirements, please refer to followings or contact your nearest Otari dealer.

VOLTAGE CONVERSION PROCEDURE:

Remove the back panel (refer to Fig. 5-1 for access information). From the top of the unit near the supply reel motor, please note the small P.C.B. assembly with the various voltage listings, i.e. 100/117/220/240 (refer to Fig. 2-3). Unsolder the wire from its present setting and resolder it to the desired position. Replace the back panel.

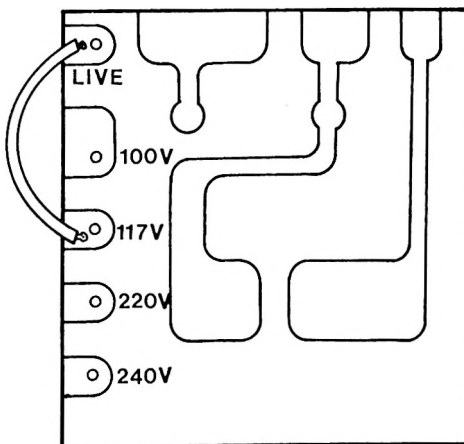

Fig. 2-3 Voltage Selection Terminal

2.5.2 SIGNAL CONNECTIONS

The microphone input (female), line input (female) and line output (male) connectors are XLR-type connectors. To wire the mating plugs, refer to Fig. 2-4 and proceed as follows.

LINE AND MIC INPUT CONNECTOR WIRING:

For balanced inputs, wire the male XLR-connector as follows:

- (1) Connect the signal leads of a two-conductor shielded cable to pin 3 (high) and pin 2 (low) of the connector.
- (2) Connect the cable shield to pin 1.

For unbalanced inputs using two-conductor shielded cable, wire the male XLR-connector as follows:

- (1) Connect the signal leads of a cable to pin 3 (high) and pin 2 (low) of the connector.
- (2) Connect the cable shield to pin 1 of the connector.
- (3) Connect a jumper from pin 1 to pin 2 of the connector.

For unbalanced inputs using single-conductor shielded cable, wire the male XLR-connector as follows:

- (1) Connect the center conductor of the single-conductor shielded cable to pin 3 of the connector.
- (2) Connect the cable shield to pins 1 and 2.

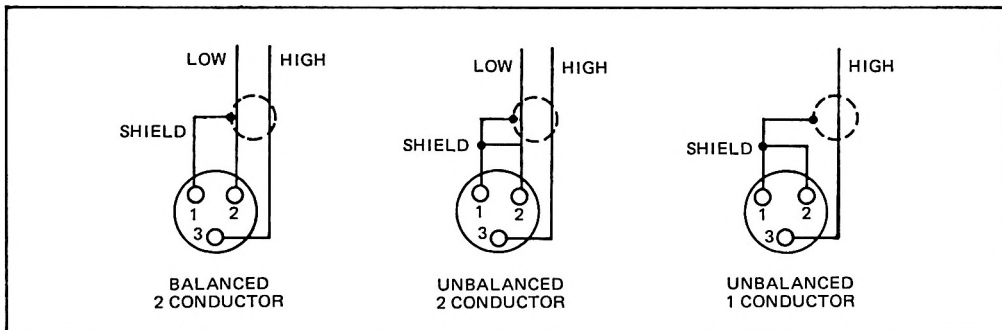

Fig. 2-4 Input/Output Assembly Connector Wiring

LINE OUTPUT CONNECTOR WIRING:

For balanced outputs, wire the female XLR-connector as follows:

- (1) Connect the signal leads of a two-conductor shielded cable to pin 3 (high) and pin 2 (low) of the connector.
- (2) Connect the cable shield to pin 1.

For unbalanced outputs using two-conductor shielded cable, wire the female XLR-connector as follows:

- (1) Connect the signal leads of the cable to pin 3 (high) and pin 2 (low) of the connector.
- (2) Connect the cable shield to pin 1 of the connector.
- (3) Connect a jumper from pin 1 to pin 2 of the connector.

For unbalanced outputs using single-conductor shielded cable, wire the female XLR-type connector as follows:

- (1) Connect the center conductor cable to pin 3 of the connector.
- (2) Connect the cable shield to pin 2 of the connector.
- (3) Connect a jumper between pins 1 and 2 of the connector.

UNBALANCED CONNECTION:

MX-5050BII series have active balanced input and output circuits. However both balanced and unbalanced connections will operate with no problems.

TRANSFORMER BALANCE CIRCUITS:

If you prefer "transformer type balanced circuits" optional accessories ZA-53T (input) and ZA-53S (output) are available. Contact your nearest OTARI dealer or OTARI for further details.

SECTION III. OPERATION

This section of the manual provides a description of all operating controls and indicators and their use in the system, and step-by-step procedures for the various modes of operation.

3.1 CONTROLS AND INDICATORS

Table 3-1 Tape Transport Controls and Indicators

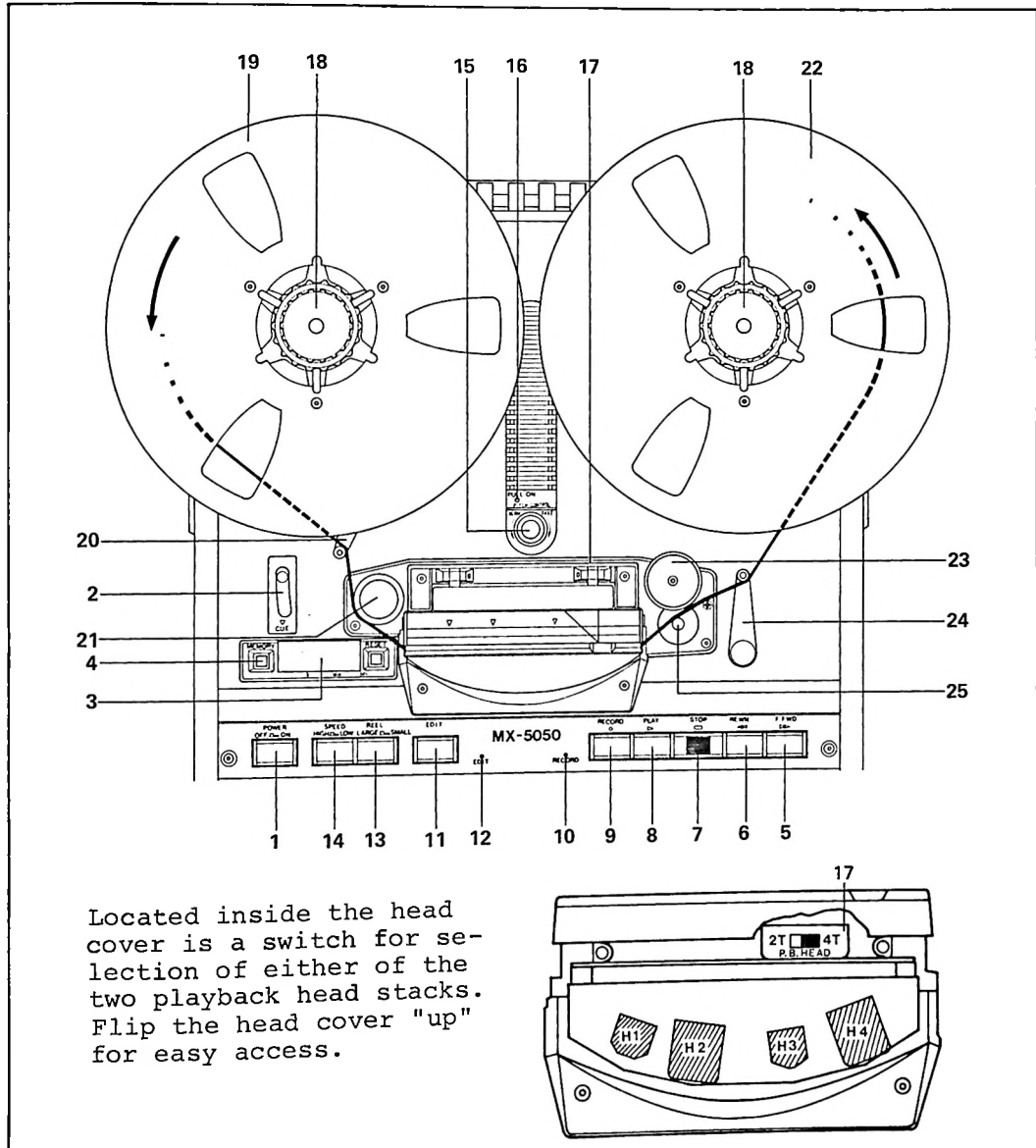

Located inside the head cover is a switch for selection of either of the two playback head stacks. Flip the head cover "up" for easy access.

Index No.	Name	Function
1	POWER Pushbutton Switch	In the depressed position, power is applied to the equipment, and the VU meters illuminate.
2	CUE Lever	In the up position, the system operates normally. In the fast forward and rewind modes, moving the lever downward permits variable control of the tape lifter to enable audio monitoring. The lever locks in the full down position.
3	Elapsed Time Indicator	A C.P.U. controlled LED display of elapsed tape time in hours, minutes, and seconds, ± 9 hr. 59 min. 59 sec. max. The pushbutton resets the display to (0.00.00).
4	MEMORY Pushbutton Switch	Depress this switch and the MX-5050B will enter the STOP mode when the elapsed time indicator displays (-0.00.00) in the rewind mode.
5	F. FWD Pushbutton Switch	Used to select the fast forward mode to run the tape from left to right at high speed. This mode may be entered into from any other mode except the edit mode.
6	REWIND Pushbutton Switch	Used to select the rewind mode to run the tape from right to left at high speed. This mode may be entered into from any other mode except the edit mode.
7	STOP Pushbutton Switch	Used to stop the tape transport and cancel the existing mode of operation.
8	PLAY Pushbutton Switch	Used to select the play mode, or used in conjunction with the RECORD pushbutton switch.

8 (Continued)

Pressing the PLAY pushbutton during the fast forward or rewind modes stops the tape, then automatically starts the play mode.

9 RECORD Pushbutton Switch

Used in conjunction with the PLAY pushbutton switch and the RECORD channel selector. With the desired channel pushbutton switches depressed, simultaneously pressing the PLAY and RECORD pushbuttons initiates the record mode and the red indicator illuminates. In the play mode, when the RECORD pushbutton is pushed, the unit enters the record mode. (This is called "Punch in".) In the record mode, when the PLAY pushbutton is pushed, the unit enters the reproduce mode. (This is called "Punch out".) Punch in and Punch out are used for overdubbing in conjunction with the sel. rep. function.

10 Record Indicator (red)

Used to indicate the record mode.

Transport record indicator	Amplifier record indicator	Transport	Recording
dark	dark	non rec. mode	x
blinks	illuminated	non rec. mode	x (ready)
remains illuminated	dark	rec. mode	x
	illuminated	rec. mode	o

Blinking means that the amplifier is in the record-ready mode. Recording is being carried out when the record indicators of both the amplifier and the transport remain illuminated.

11 EDIT Pushbutton Switch

Used to initiate the edit mode to aid in cutting out unwanted tape.

11	(Continued)	When the EDIT pushbutton is depressed the green indicator illuminates and power is disconnected to the takeup reel. When the play pushbutton switch is then depressed it causes the supply reel to rotate and tape to spill off on the takeup side of the transport. Other operations are halted.
12	EDIT Indicator (green)	Illuminates when the EDIT pushbutton switch is depressed.
13	Large/Small REEL Pushbutton Switch	An alternate-action pushbutton switch used to select the supply and takeup-reel tape tension for either large or small reel-diameter hubs. Place the pushbutton in the "in" (Small position) for reels with EIA hubs (2-1/4 inch hubs). Place the pushbutton in the "out" (Large position) for reels with NAB hubs (4-1/2 inch diameter hubs). (THE SAME SIZE REELS SHOULD BE USED ON BOTH TURNTABLES.)
14	HIGH/LOW Speed Pushbutton Switch	An alternate-action pushbutton switch used to select operating speeds. (15/7.5 ips) When machine is converted to a low speed version, this switch selects tape speeds of 7-1/2 ips or 3-3/4 ips. Refer to page 5-1 for conversion procedure.
15	PITCH CONTROL	Used to control tape speed. The capstan's speed can be controlled within $\pm 7\%$ of the selected speed. When the PITCH CONTROL knob is pulled out and turned clockwise, capstan speed increases. When pulled out and turned counterclockwise, capstan speed decreases. PITCH CONTROL FUNCTIONS IN BOTH THE RECORD AND PLAY MODES.
16	PITCH CONTROL Indicator (red)	Lights when the PITCH CONTROL switch is pulled out (Variable).

17	Reproduce Head Selector Switch	Used to select the appropriate reproduce head stack to conform to the type of tape to be reproduced. (Refer to Sec. 1.1.3.)
18	NAB Hub Reel Hold Down Knobs	Used to attach EIA or NAB hub reels to the reel table. (Refer to Sec. 3.2.1.)
19	Supply Reel	Used to supply tape for reproduction or recording.
20	Tension Arm	Used to eliminate tape tension fluctuations.
21	TACHO Pulse Generator Roller	Used to generate the pulses for the elapsed time indicator.
22	Takeup Reel	Used to take up tape.
23	Pinch Roller	Used to correctly transmit the rotation of the capstan to the tape.
24	Tension Arm with Safety Switch	Used to eliminate tape tension fluctuations. When tape is exhausted, supply and takeup reel rotation is automatically stopped by the safety switch attached to the tension arm.
25	Capstan Shaft	The shaft used to keep speed constant while in the reproduce and record modes.

Table 3-2 shows the location and function of each control and indicator on the record/reproduce electronics control panel.

Table 3-2 Record/Reproduce Electronics Controls and Indicators

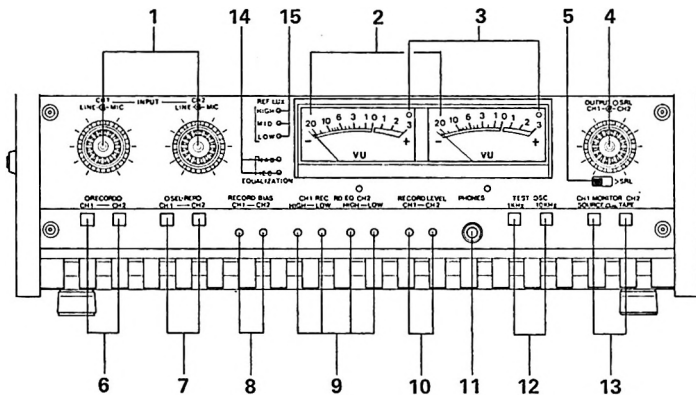

Index No.	Name	Function
1	LINE/MIC INPUT Level Control	Used to control the recording level line input (outside knob) and microphone (inside knob) of the corresponding channel.
2	VU Meters	Indicate the record and playback level of the corresponding channel depending on the mode of operation and position of the MONITOR SOURCE/TAPE switch (Index No. 13 in this table). The meters are illuminated when the recorder is turned on.
3	Peak Indicators (red)	Used to show signal peaks. When the input signal level exceeds the standard level by 15 dB, the peak indicator lights. At a frequency of 700 Hz, the magnetic flux at the standard level is 185 nWb/m. When the peak indicator lights, the level is 1040 nWb/m. This trigger level may be adjusted.

4 OUTPUT Level Controls

Used to control the playback level of the corresponding channel. (Control is deactivated when the SRL switch is in the "SRL" position.)

5 SRL Switch and Indicator (red)

In the "SRL (Standard Reference Level)" position, the red indicator is illuminated. The playback level is then determined by an internal preset potentiometer. The SRL can be selected by the Record level switch on the rear panel as follows:

RECORD LEVEL	Standard Reference Level	
	Flux Level	Based on
L	185 nWb/m	Ampex Operating level
M	250 nWb/m	MRL reference fluxivity of 250 nWb
H	320 nWb/m	BASF or MRL IEC reference level

In the normal position, the reproduce level is controlled by the OUTPUT controls of the corresponding channel.

DO NOT TURN THIS SWITCH OFF UNLESS YOU TURN THE LINE OUTPUT LEVEL CONTROLS (INDEX NO. 4 IN THIS TABLE) DOWN TO THE MINIMUM LEVEL WHILE A SIGNAL IS BEING OUTPUT TO OTHER EQUIPMENT, TO PREVENT POSSIBLE DAMAGE.

6 RECORD Selector Switch and Indicator (red)

Used to select channels for recording, and used in conjunction with the PLAY and RECORD pushbutton switches (Index Nos. 8 and 9 of Table 3-1). In the "out" position this switch prevents activation of the channel record mode.

6	(Continued)	In the "in" position it permits the channel record mode to be entered into and the red indicator is illuminated.
7	SEL/REP Selector Switch and Indicator	In the SEL. REP. (Selective Reproduction) "out" position, the signal on the tape is reproduced normally. In the SEL/REP "in" position, the green indicator is illuminated and the signal on the tape is reproduced by the record head (rather than by the reproduce head) to permit recording on one channel to synchronize with the other channel.
8	RECORD BIAS Adjustment Control	Used to adjust the amplitude of the bias current in accordance with the tape being used for optimum performance. Used in conjunction with the Test OSC function (Index No. 12 in this table).
9	RECORD EQ Adjustment Control	Used to adjust record equalization of corresponding channels and speed modes (HIGH or LOW).
10	RECORD LEVEL Adjustment Control	Used to make fine adjustments when different types of tape are to be used.
11	PHONES Jack	Receptacle for headphones. Used to monitor the input or output signal as selected by the Monitor SOURCE/TAPE selector switch (Index No. 13 in this table). (Load impedance: 8 ohms or greater)
12	TEST OSC Push-button Switch	When the left button is held down, a 1 kHz Test tone is generated and fed to the line input circuit. The right button (which locks down) generates a 10 kHz tone. These tones are used for cue tone recording and Record Bias adjustment (Index No. 8 of the table).

13	MONITOR SOURCE/ TAPE Switch	In the "out" (SOURCE) position, the input signal is fed to the LINE OUT connectors, the PHONES jack, the VU meters, and the peak indicators. In the "in" (Tape) position, the signal being reproduced is fed to the LINE OUT connectors, the PHONES jack, VU meters, and the peak indicators.
14	EQ Selection Indicator	Located on the amplifier front panel are 2 LED EQ Selection Indicator Displays which indicate the position of the NAB or IEC EQ switch which is located on the back of the unit.
15	Record Level Selection Indicator	Located on the front amplifier front panel are 3 LED Record Level Selector Indicator Displays which indicate the position of the Record Level Selector switch which is located on the back of the unit.

3.2 OPERATING INFORMATION

3.2.1 USE OF THE REEL HOLD DOWN KNOBS

NAB hub reel hold down knobs are used as follows:

When an EIA hub (2-1/4 inch diameter hub) is used;

- (1) Remove the NAB reel hold down knob by turning the inner knob counterclockwise.
- (2) Place the reel on the reel table.
- (3) Place the reel hold down knob on the reel and fix it by turning the inner knob clockwise.

When an NAB hub (4-1/2 inch diameter hub) reel is used;

- (1) Place the reel hold down knob on the reel table and lock it by turning the inner knob clockwise.
- (2) Place the NAB hub reel on the reel table and fix it by pulling and turning the outer knob.

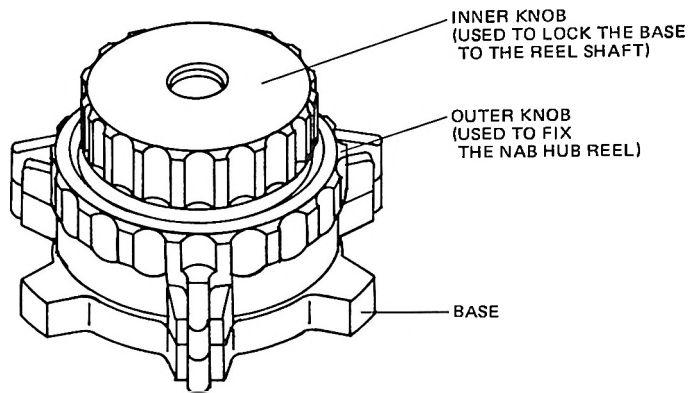

Fig. 3-1 Reel Hold Down Knobs

3.2.2 PRE-OPERATING PROCEDURE

After the equipment has been installed, as described in Sec. 2 of this manual, and the operator has become familiar with all the operating controls and indicators, described in Tables 3-1 and 3-2, prepare the recorder for operation as follows.

- (1) Place the POWER switch in the "on" position. The VU meter lights will illuminate.
- (2) If metal reels are to be used, use reel-adjusting discs (shims) between the reels and the turntables. Place a reel of tape on the supply (left-hand) turntable. Note that the reel must turn counterclockwise as tape is pulled off the reel. Place the same size empty reel on the takeup (right-hand) turn-table.
- (3) Thread the tape as shown in Fig. 3-2, and place the end of the tape in the slot of the empty reel.
- (4) Set the HIGH/LOW SPEED switch to the desired tape speed.
- (5) Set the LARGE/SMALL REEL switch to conform to the size of the reel hub diameter being used. Place the switch to the "out" (LARGE position) for NAB hubs (4-1/2 inch diameter) or to the "in" (SMALL position) for EIA hubs (2-1/4 inch diameter). (THE SAME SIZE REELS SHOULD BE USED ON BOTH TURN-TABLES.)

- (6) Set the reproduce head selector switch (Index No. 17 in Table 3-1) to the appropriate position as determined by the track format of the tape to be reproduced.
- (7) If desired, connect a headset or monitor speaker/amplifier to the PHONE jack.

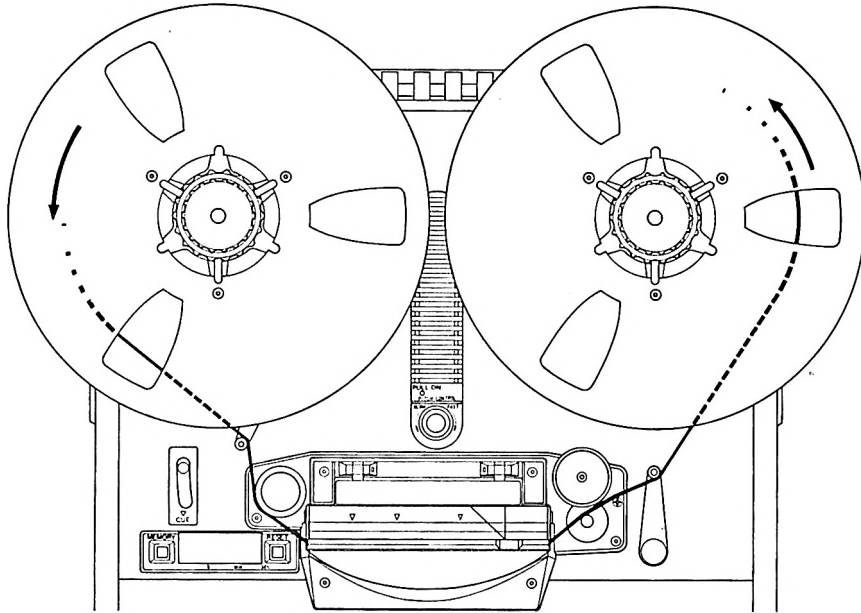

Fig. 3-2 Tape Threading

3.2.3 REPRODUCTION

To reproduce, proceed as follows:

- (1) Perform all steps in the pre-operating procedure.
- (2) Set the channel RECORD selector switch(es) to the "out" position.
- (3) Set the reproduce head selector switch to its appropriate position.
- (4) Set the channel MONITOR selector switches to their TAPE "in" positions.
- (5) Press the PLAY pushbutton to begin reproducing the pre-recorded tape.

- (6) Adjust the channel OUTPUT level control(s) for the desired output level or set the SRL switch to the "SRL" position.
- (7) When the desired program has been reproduced, press the STOP pushbutton.

3.2.4 NORMAL RECORDING

To record normally, proceed as follows:

- (1) Perform all steps in the pre-operating procedure.
- (2) Set the desired RECORD selector switches to the "in" position for the channel(s) selected for recording. The corresponding red indicator(s) will illuminate to indicate the selected channel(s). Simultaneously the tape transport RECORD indicator will begin to blink.
- (3) Set the corresponding MONITOR SOURCE/TAPE switch to the "out" (SOURCE) position.
- (4) Adjust the corresponding LINE/MIC INPUT level control(s) so that the VU meter(s) indicates 0 for most audio peaks. (It is advisable to adjust the channel input levels so that the peak indicator lamps, located in the VU meter housings, blink occasionally.)
- (5) Push the elapsed time indicator pushbutton to reset the display to (0.00.00).
- (6) Press the PLAY and RECORD pushbuttons simultaneously to start recording on the selected channel(s). The tape transport RECORD indicator will cease blinking and instead will remain illuminated.
- (7) While recording, the input signal of each channel can be compared with the signal reproduced on each channel by pressing the MONITOR switch to the "in" (TAPE) position.
- (8) After recording is completed, but while still in the record mode, once again press the PLAY pushbutton to enter directly into the play mode without stopping the tape transport (punch out).
After punching out, if desired, press the RECORD pushbutton to enter directly into the record mode without stopping the tape transport (punch in). If further recording is not necessary, press the STOP pushbutton to stop tape motion and deactivate the record mode.

3.2.5 RECORDING WITH SELECTIVE REPRODUCTION

The selective reproduction function causes the reproduced audio to be derived from the record head rather than from the reproduce head. This permits a recording to be made on another channel synchronized (in phase) with the channel being reproduced. To record with selective reproduction, proceed as follows.

- (1) Perform all steps in the pre-operating procedure.
- (2) Perform all steps in the normal recording procedure for the channel to be recorded.
- (3) Rewind the tape to the point where selective reproduction is to begin.
- (4) Set the selective reproduction (SEL/REP) switch to the "in" position for the channel to be monitored while the recording is being made.
- (5) Set the RECORD selector switch to the "in" position for the channel to be recorded.
- (6) Set the MONITOR selector switch to the "in" (Tape) position for the channel being monitored.
- (7) Set the MONITOR selector switch to the "out" (Source) position for the channel to be recorded.
- (8) Adjust the LINE/MIC INPUT level control so that the VU meter indicates 0 for most audio peaks. (It is advisable to adjust the channel output levels so that the peak indicator lamps, located in the VU meter housings, blink occasionally.)
- (9) Press the PLAY pushbutton to start tape motion. At the point where overdub is desired press the RECORD pushbutton to start recording on the selected channel(s).
- (10) When recording is complete, press the STOP pushbutton to stop tape motion and deactivate the record mode, or punch-out by pressing the PLAY pushbutton.

- NOTES:
1. If this unit is a full-track model, the SEL. REP. function is not included.
 2. The pitch control is used to finely adjust one track with another track(s). It can be used in both the Record and Reproduce modes.
 3. The SEL. REP. mode has priority over the Record mode in this unit. (While the SEL. REP. pushbutton(s) is (are) pushed, the corresponding channel(s) can not enter the record mode.)

3.2.6 FAST WINDING

For fast-winding operations, and for editing or cueing, press the F. FWD. or REWIND pushbutton as appropriate. These pushbuttons can be pressed alternately without having to press the STOP pushbutton between fast-winding operations. These modes may be entered into from any other mode except the edit mode. Pressing PLAY during a fast-winding mode causes the tape to automatically come to a stop and then enter into the play mode. In a fast-winding mode, the tape lifters are automatically actuated and lift the tape away from the heads. To monitor the tape in a fast-winding mode, the position of the tape lifters can be varied by operation of the CUE lever. Thus the distance of the tape from the heads may be varied to control the signal level from the tape.

3.2.7 EDITING AND SPLICING TAPE

For editing and splicing operations, the CUE lever can be used in fast-winding modes to quickly locate the desired program material. In addition, there is an EDIT mode of operation, used as follows:

Depressing the EDIT pushbutton while in the play mode removes power from the takeup reel and causes the tape to be spilled off on the takeup side of the transport. This mode is used to facilitate cutting out unwanted tape. The edit mode can also be entered into from the stop mode by pressing the PLAY pushbutton while the EDIT pushbutton is in its depressed position.

The tape-splicing block (Fig. 3-3) mounted on the head cover can be used to hold the tape for ease in cutting the tape with a single-edged razor blade and applying splicing tape. Use 7/32-inch wide splicing tape (3M Co., No. 41). Never use cellophane tape. The tape splicing block has the following features:

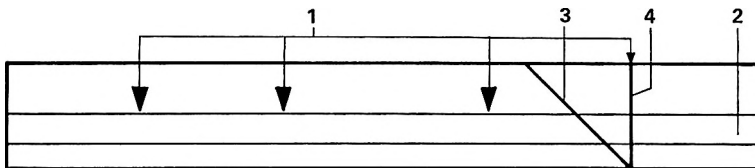

Fig. 3-3 Tape Splicing Block

- 1 Head-stack indicator marks: Indicates location of the individual head stacks.
- 2 Tape-guide channel: Holds the tape for ease of cutting and splicing.
- 3 45° cutting guide : Used to guide tape cutter for a diagonal cut.
- 4 90° cutting guide : Used to guide tape cutter for a vertical cut.

SECTION IV
PREVENTIVE MAINTENANCE AND ADJUSTMENTS

This section provides information on preventive maintenance, cleaning demagnetizing, lubrication and electronic adjustment procedures which should be carried out periodically to maintain optimum performance. Also refer to Sections V and VI for more details on adjustments.

4.1 TEST AND MAINTENANCE EQUIPMENT REQUIREMENTS

Table 4-1 Test and Maintenance Items

Item	Suggested Model	Used for
Head Cleaner	Otari ZA-51B	Cleaning the heads.
Isopropyl Alcohol	Any (Otari Cleaning Kit ZA-51B contains the above cleaning materials.)	Cleaning the tape guides, capstan, and capstan pinch roller.
Head Demagnetizer	Any	Demagnetizing the heads and tape guides.
Lubricating Oil	Otari Lubricating Oil PZ9E003	Lubricating the capstan of the DC servo control motor.
Reproduction Alignment Tape	NAB 3-3/4 ips: MRL 21F101 7-1/2 ips: MRL 21T204 15 ips: MRL 21J205 IEC 7-1/2 ips: MRL 21T302 15 ips: MRL 21J303	Setting the operating standard reference levels, and adjusting frequency response. (Refer to page 5-10.)

Audio Oscillator 20 to 20 kHz	Hewlett-Packard 204C or 209D	Setting record equalization
AC Voltmeter	Hewlett-Packard 400L or 400FL	Setting record and playback frequency response

4.2 PREVENTIVE MAINTENANCE

For optimum performance, cleaning and demagnetizing should be performed after every eight hours of operation, and lubrication should be carried out at the recommended times as indicated below.

4.2.1 CLEANING

Oxide particles from the magnetic tape tend to collect on components in the tape path and degrade the performance of the recorder. The heads and all other components in the tape path must be cleaned after every eight hours of operation, or more frequently if visual inspection indicates cleaning is required. To clean the head assembly, proceed as follows:

- (1) Lift the head cover as illustrated in Fig. 4-1.
- (2) Clean each head stack thoroughly with a cotton-tipped applicator dampened with head cleaner.

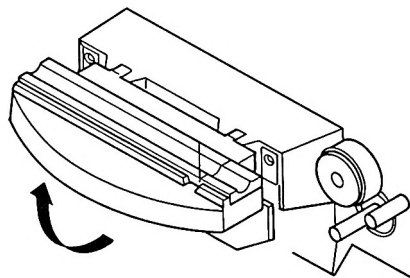

Fig. 4-1 Lifting the Head Cover

CAUTION: WHEN CLEANING THE HEADS, USE ONLY THE RECOMMENDED SOLVENT (HEAD CLEANER) TO AVOID DAMAGING THE HEADS. KEEP THE HEAD CLEANER AWAY FROM PLASTIC FINISHES AND THE CAPSTAN PINCH ROLLER. DO NOT USE METAL TOOLS THAT CAN SCRATCH THE HEADS.

- (3) Use isopropyl alcohol to clean all tape guiding components including the capstan shaft and the rubber capstan pinch roller.

4.2.2 DEMAGNETIZING

The heads and tape guiding components in the tape path should be demagnetized after every eight hours of operation. These components can acquire permanent magnetization that increases signal noise and distortion, and partially erase high frequencies on recorded tape. Use a hand-held demagnetizer to demagnetize all components in the tape path as follows:

(1) Turn the unit's power off and remove any recorded tape near the transport. The tape could be partially erased by the demagnetizer.

(2) Lift the head cover as illustrated in Fig. 4-1.

(3) Cover the demagnetizer tips with adhesive tape to prevent scratching the head stacks.

(4) With the demagnetizer held away from the transport, connect the demagnetizer to a power source.

(5) Move the demagnetizer tips slowly close to the head, lightly touch the face of one head stack and slowly move the tips up and down the stack several times. Then slowly withdraw the demagnetizer as shown in Fig. 4-2.

(6) Repeat step (5) for each head stack.

(7) Repeat the procedure in step (5) for each guide and other metallic parts in the tape path.

(8) Move the demagnetizer slowly away from the transport at least three feet, and then disconnect the power from the demagnetizer.

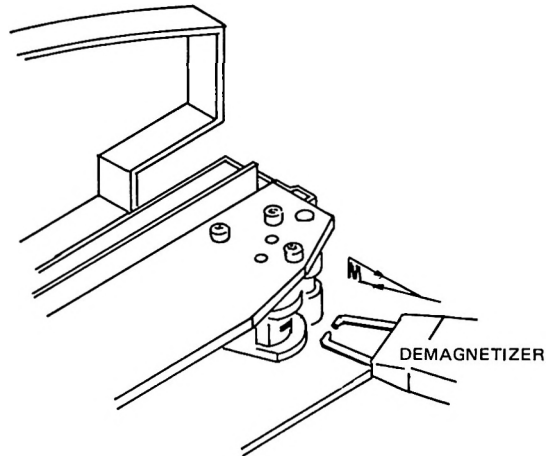

Fig. 4-2 Demagnetizing

4.2.3 LUBRICATION

The only component requiring lubrication is the capstan.

Lubricate the capstan every four months, or after each 1,000 hrs. of operation (whichever occurs first), or as required using the recommended lubricating oil (Table 4-1). For lubrication, proceed as follows, referring to Fig. 4-3:

- (1) Remove the pinch roller cap by turning the cross-head screw counterclockwise.
- (2) Remove the pinch roller from the pinch roller shaft.
- (3) Remove two screws attaching the head housing cover to the tape deck. Remove the head housing cover.
- (4) Remove three screws that hold the lower head cover (skirt) to the deck panel. Remove the cover.
- (5) Remove the metal dust cap from the capstan shaft by turning it counterclockwise.
- (6) The felt collar should now be visible. Apply two or three drops of oil onto this felt collar. Please do not over-lubricate.
- (7) Wipe off any excess oil and replace the dust cap. Also replace pinch roller and pinch roller cap after replacing lower head cover (skirt) and head housing cover.

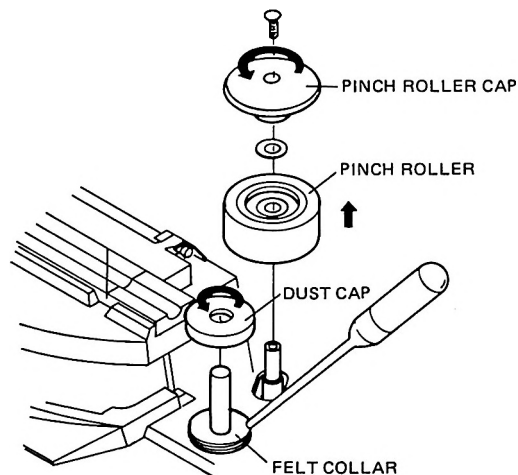

Fig. 4-3 Lubrication

4.3 ELECTRONIC TRIMMING

Electronic trimming consists of setting the record bias, and setting the record equalization and record level. Note that the reproduction adjustments must be performed before making the recording adjustments. These electronic adjustments should be performed at regularly scheduled intervals, and when changing from one type of recording tape to another.

4.3.1 RECORD BIAS ADJUSTMENT

For optimum performance, biasing should be done using the type of tape that will normally be used. To set the bias level, carry out the following procedure for each channel.

- (1) Thread bulk-erased tape on to the recorder.
- (2) Set the SRL calibration switch to the SRL position. Set the SPEED switch to the "7-1/2" position.
- (3) Start the tape in the record mode.
- (4) Press the 1 kHz TEST OSC pushbutton and set the record level control for a 0 reading on the VU meters.
- (5) Adjust the RECORD BIAS adjustment trim pot for a maximum reading on the VU meters.

4.3.2 RECORD LEVEL ADJUSTMENT

- (1) Set the Record level switch to the "H", "M", or "L" position according to the tape being used or the equalization standard.
- (2) Thread bulk-erased tape on to the recorder.
- (3) Set the SRL calibration switch to the "SRL" position and the Monitor switch to the "SOURCE" position.
- (4) While pressing the 1 kHz TEST OSC pushbutton, adjust the line input levels so that the VU meters indicate 0 VU.
- (5) Change the mode of the Monitor switch from "SOURCE" to "TAPE".
- (6) Start the tape in the record mode, and adjust the appropriate RECORD LEVEL adjustment trim pot so that the VU meter indicates 0 VU.

4.3.3 RECORD EQUALIZATION ADJUSTMENT

Set the record equalization for each speed and each channel as follows:

- (1) Thread bulk-erased tape on to the recorder.
- (2) Connect an audio oscillator to the INPUT of the recorder and set the oscillator's frequency to 1 kHz.
- (3) Set the SRL switch to the "SRL" position.
- (4) Start the tape in the record mode.
- (5) For the 15 ips tape speed, adjust the record levels so that the VU meters indicate 0 VU. For the 3-3/4 and 7-1/2 ips tape speeds, set the record levels so that the VU meters indicate -10 VU. Next, set the SRL switch to its normal position and adjust the OUTPUT level controls so that the VU meters indicate 0 VU.
- (6) Change the audio oscillator's output to 10 kHz.
- (7) As a preliminary setting, adjust the appropriate low or high speed equalizer so that the VU meters indicate 0 VU.
- (8) Check the response above and below 10 kHz and trim the record equalizer for the response desired.

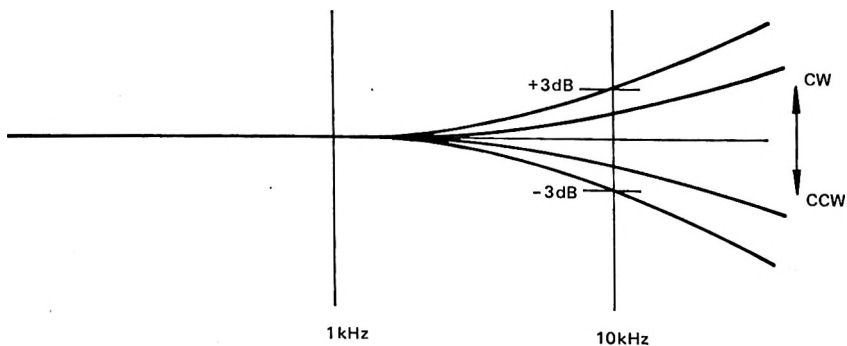

Fig. 4-4 Record Equalization Adjustment

SECTION V. AMPLIFIER ADJUSTMENTS

This section provides informations on amplifier adjustment in detail. Before starting adjustment, read through all informations described here to have complete adjustment and performance.

5.1 ACCESS TO THE AMPLIFIER

Here the access to the amplifier is described and also rear and side board panel removal is illustrated. Please refer to the illustrations on next pages.

- (1) Remove the 4 screws marked "A" from the bottom panel and remove the bottom panel marked "B".
- (2) Remove the 2 screws marked "C" in Fig. 5-1, also remove the 2 screws marked "D". Then pull the amplifier section up and rotate it toward you.
- (3) Referring to Fig. 5-3, the location of all the pots and switches are illustrated and are explained in the list following. This list would give you the convenience in adjusting the amplifier.

5.2 AMPLIFIER P.C.B. ASSEMBLY LAYOUT

Figure 5-3 is the major parts layout on the amplifier P.C.B. assembly with the parts list following on next page. They may give you the necessary location information of the parts to adjust the amplifier.

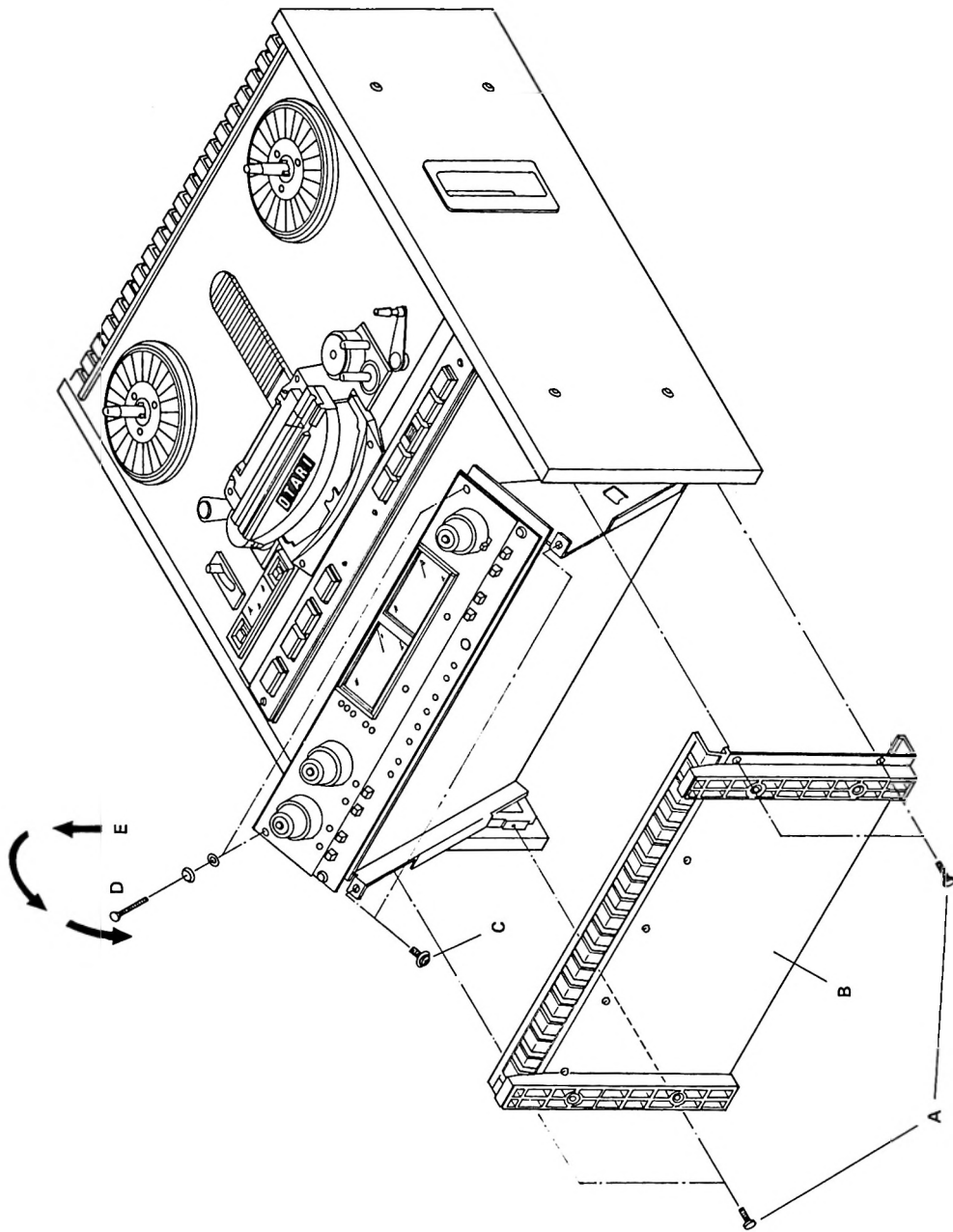

Fig. 5-1 Access to the Amplifier

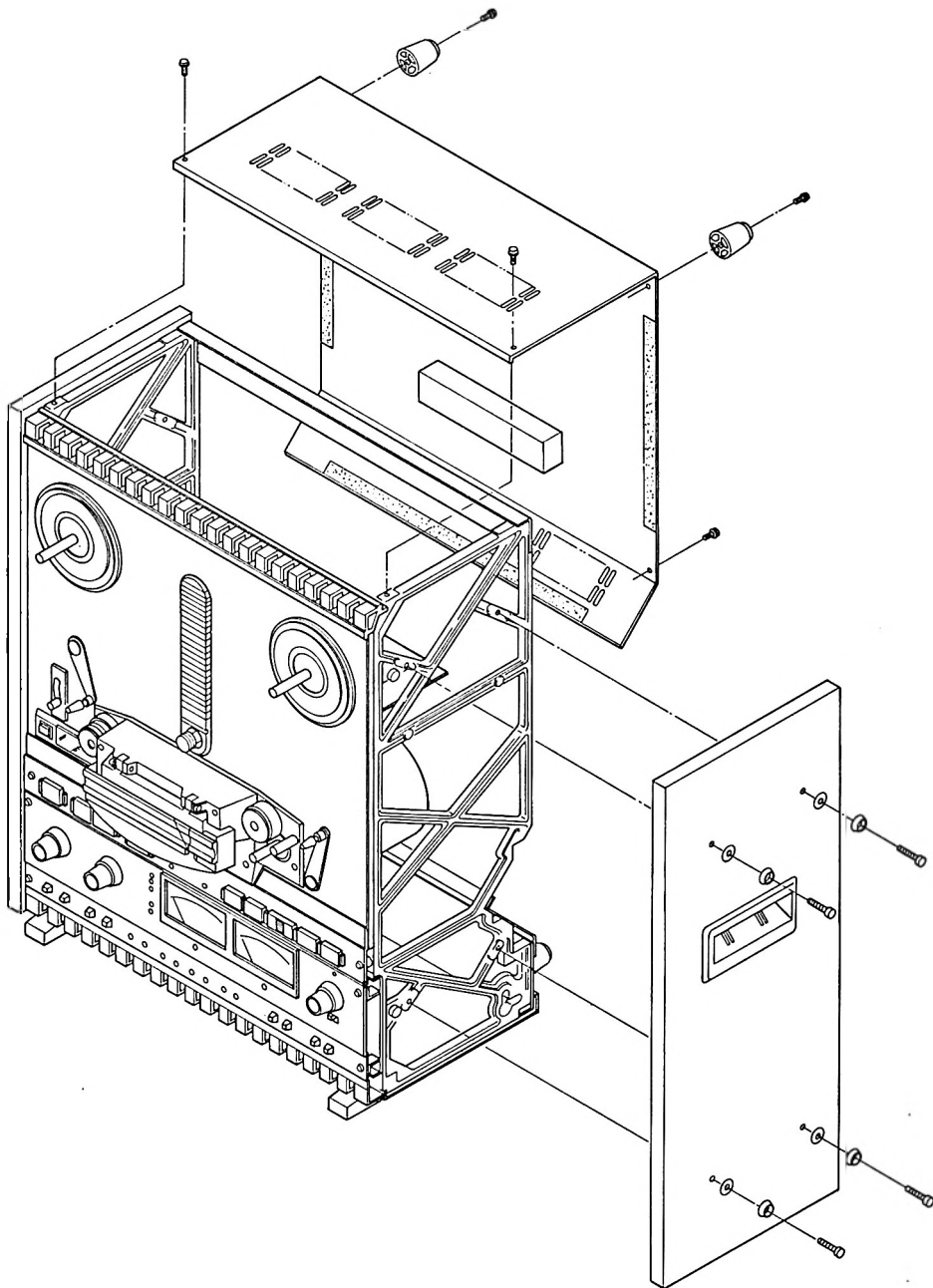

Fig. 5-2 Rear Panel and Side Board Removal

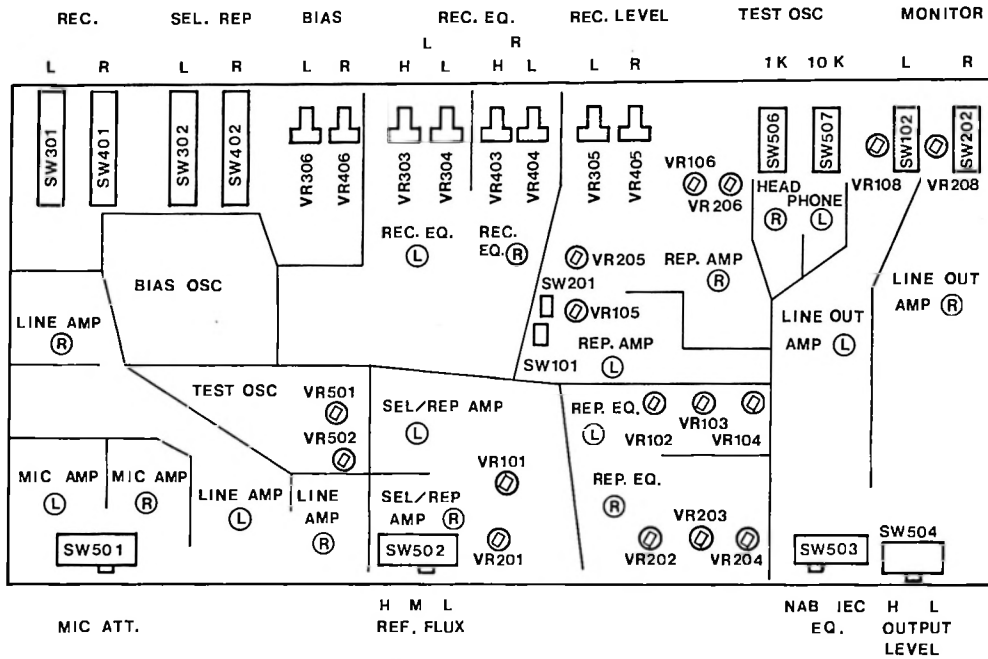

Fig. 5-3 Pattern Layout (bottom view)

LIST OF THE MAIN PARTS FOR ADJUSTMENT OF AMPLIFIER

<u>Ref. No.</u>		<u>Ref. No.</u>	
SW301	RECORD Selection LCH	VR106	SRL LEVEL (REP) LCH
SW401	RECORD Selection RCH	VR206	SRL LEVEL (REP) RCH
SW302	SEL/REP Selection LCH	VR108	SOURCE LEVEL LCH
SW402	SEL/REP Selection RCH	VR208	SOURCE LEVEL RCH
SW506	TEST OSC 1 kHz	VR501	10 kHz TEST OSC LEVEL
SW507	TEST OSC 10 kHz	VR502	1 kHz TEST OSC LEVEL
SW102	MONITOR Selection LCH	VR101	SEL/REP SRL ADJ. LCH
SW202	MONITOR Selection RCH	VR201	SEL/REP SRL ADJ. RCH
SW501	MIC ATTENUATOR	VR205	LOW COMP. Pot RCH
SW502	RECORD LEVEL Selection	SW201	LOW COMP. Selection RCH
SW503	EQ (NAB or IEC) Selection	VR105	LOW COMP. Pot LCH
SW504	OUTPUT LEVEL Selection	SW101	LOW COMP. Selection LCH
VR306	BIAS Adjustment Pot LCH	VR102	REPRODUCE EQ Pot 15 ips LCH
VR406	BIAS Adjustment Pot RCH	VR103	REPRODUCE EQ Pot 7.5 ips LCH
VR303	RECORD EQ Pot LCH High Speed	VR104	REPRODUCE EQ Pot 3-3/4 ips LCH
VR304	RECORD EQ Pot LCH Low Speed	VR202	REPRODUCE EQ Pot 15 ips RCH
VR403	RECORD EQ Pot RCH High Speed	VR203	REPRODUCE EQ Pot 7.5 ips RCH
VR404	RECORD EQ Pot RCH Low Speed	VR204	REPRODUCE EQ Pot 3-3/4 ips RCH
VR305	RECORD LEVEL LCH		
VR405	RECORD LEVEL RCH		

5.3 BLOCK DIAGRAM AND CIRCUIT DESCRIPTION

Block diagram of the amplifier is illustrated at Fig. 5-4. Refer to this illustration and schematics on the last section of this manual for more understanding circuit descriptions.

5.3.1 REPRODUCE CIRCUIT

Please refer to A1062 Rec & REPRO AMP schematics on last section of this manual. All descriptions are made with the circuit terms in the schematics.

The reproduce head is connected to #9-4 and #9-3 and the signal reproduced goes to the input stage of EQ amplifier through Q105, which is the gate switching "Sel-Rep" signal and "Reproduce" signal. Sel-Rep signal comes through brake contact of the record relay to sel-rep amplifier. Sel-Rep amplifier is composed by Q101, Q102 and Q103 amplifiers and VR101 is for sel-rep level adjusting. Q104 is the same switching gate as Q105 in reproduce circuit. IC501 is an EQ amplifier with many resistors inserted to the NF circuits by means of FET switching (Q106 ~ Q111).

IC101-1/2, VR105 and SW101 are for low frequency compensation circuit. The equalized reproduced signal is transferred to the other half of IC101 through VR106, NORMAL-SRL switch and MONITOR switch. VR106 is SRL adjusting potentiometer and VR107 is output level adjusting potentiometer on the front amplifier panel. Reproduce signal line is grounded through R139 and Q112 at hot end of VR106. The base of Q112 is driven by FAST command, which mutes the audio signal during FAST WINDing.

The audio signal selected by monitor switch is supplied to PEAK indicator circuit and pre-output amplifier. The amplitude gain of this amplifier is decided by R147 ~ R149 and two transistors to which control command is running through record level selecting switch, SW502-b.

The output of pre-output amplifier goes to phones amplifier circuit and active balance line out circuit. And also it is connected to emitter of Q115 which is final stage of power-on muting circuit. IC102, IC103 and Q117 ~ Q120 are for active balance circuit which is connected to the output XLR connector.

5.3.2 RECORD CIRCUIT

There are two input circuits in the record amplifier. One is MIC INPUT and the other is LINE INPUT. Both are active balance circuits. MIC input signal is output to VR301 which is MIC level potentiometer on the Amplifier front panel. Also LINE input signal is output to VR302 which is LINE level potentiometer on the panel. Q301 and Q302 are inserted before the VR302. Both

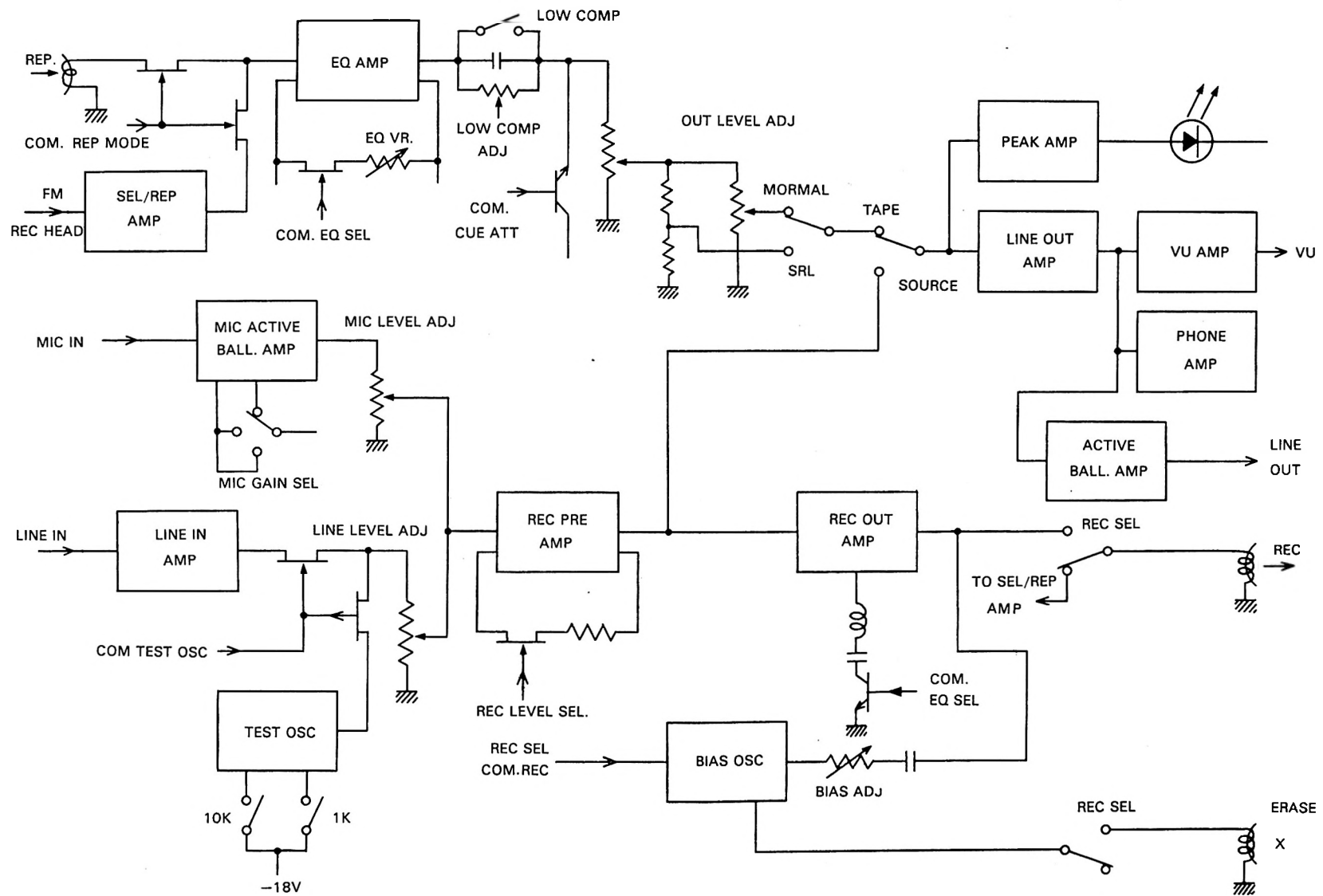

Fig. 5-4 Block Diagram

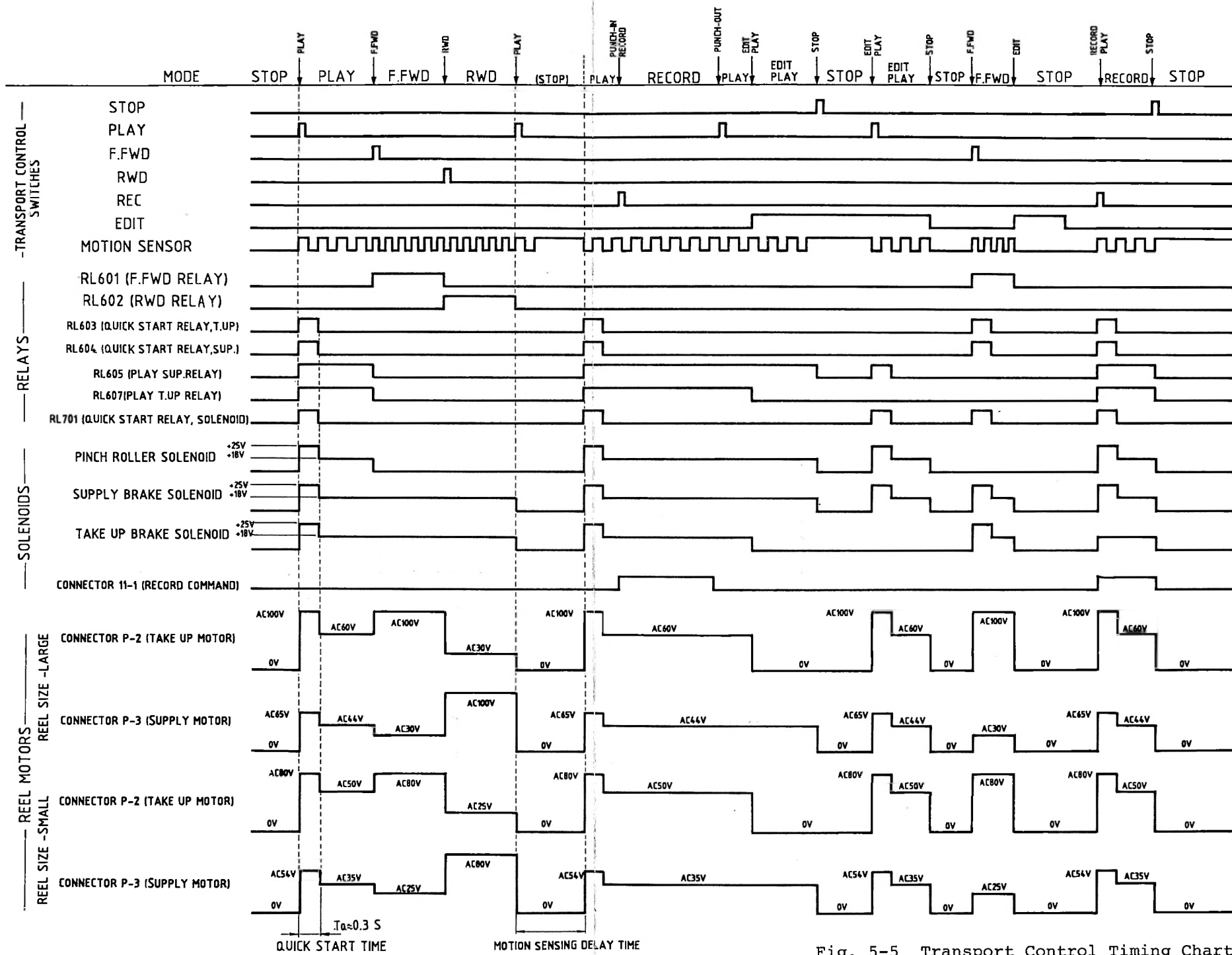

Fig. 5-5 Transport Control Timing Chart

transistors are switching gates to feed 1 kHz or 10 kHz sine-wave signal to the line amplifier. Then both input signals are mixed together at the input stage of line pre-amplifier IC505. Its gain is also controlled by record level selecting switch SW502-b.

IC302 with 3 FET's Q305 ~ 306 makes half of the record EQ circuit and VR305 is for record level adjustment. Then record signal is supplied to other half of the record EQ circuit composed with IC302, Q313 ~ Q317 and many EQ components. The output of the record EQ circuit is fed to the output stage of BIAS oscillator through bias trap circuit composed with L301 and other CRs.

Bias circuit is composed by Q509, Q510 and T501. Full output of bias circuit is fed to erase head and its tapped output is fed to record head through VR306 and C320. VR306 is a bias adjusting potentiometer. L302 is a dummy load for the compensation in the case of single channel recording. DC voltage for bias oscillation circuit is fed through voltage control circuit, Q504 ~ 508. Those are for click-less recording. IC506 and many C-R components are for sine-wave test oscillator circuit.

5.4 TRANSPORT CONTROL TIMING CHART

Fig. 5-5 is a transport control timing chart of MX-5050BII. All control timings are shown in the chart including record command.

5.5 AMPLIFIER ADJUSTMENT

Here amplifier adjustment is well described in order from test tape selection to record EQ adjustment. There are short descriptions on amplifier adjustment and locations and functions of each potentiometer and other stuffs for adjustment at Section IV. So please refer to Section IV also.

5.5.1 TEST TAPE SELECTION

MX-5050BII Series are adjusted with the standard test tapes listed in the table below. We recommend you to use the same type of standard test tapes.

Table 5-1 Reproduce Alignment Test Tape

Tape Speed	Equalization	MRL Catalog Number	Reference Level
15 ips	NAB	21J205	250 nwb/m *1
7 $\frac{1}{2}$ ips	NAB	21T204	250 nwb/m *1
3 $\frac{3}{4}$ ips	NAB(=IEC)	21F101	200 nwb/m *1
15 ips	IEC	21J303	320 nwb/m *2
7 $\frac{1}{2}$ ips	IEC	21T302	320 nwb/m *2

*1 Short circuit flux density

*2 Open circuit flux density which corresponds to 290 nwb/m in short circuit flux density

5.5.2 HEAD ALIGNMENT

- (1) Figure 5-6 shows head assembly of the MX-5050BII. Each head unit is supported with three screws and springs to the head mounting plate.

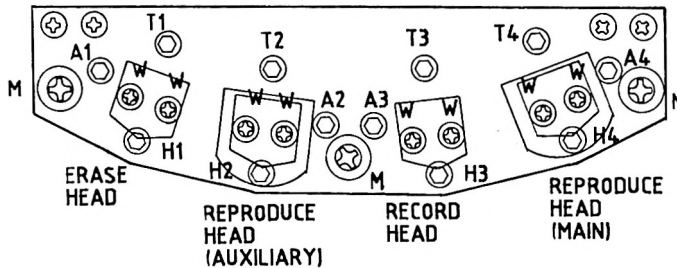

Fig. 5-6

- (2) When replacing a whole head stack, take out three screws marked M in the figure.
- (3) When replacing only a head unit, take out three screws marked T_n, A_n and H_n of the head.
- (4) When new head unit or new head stack is mounted, first roughly adjust the height of the head with the tape thread as illustrated in Fig. 5-7. To adjust the height turn three screws by same amount.

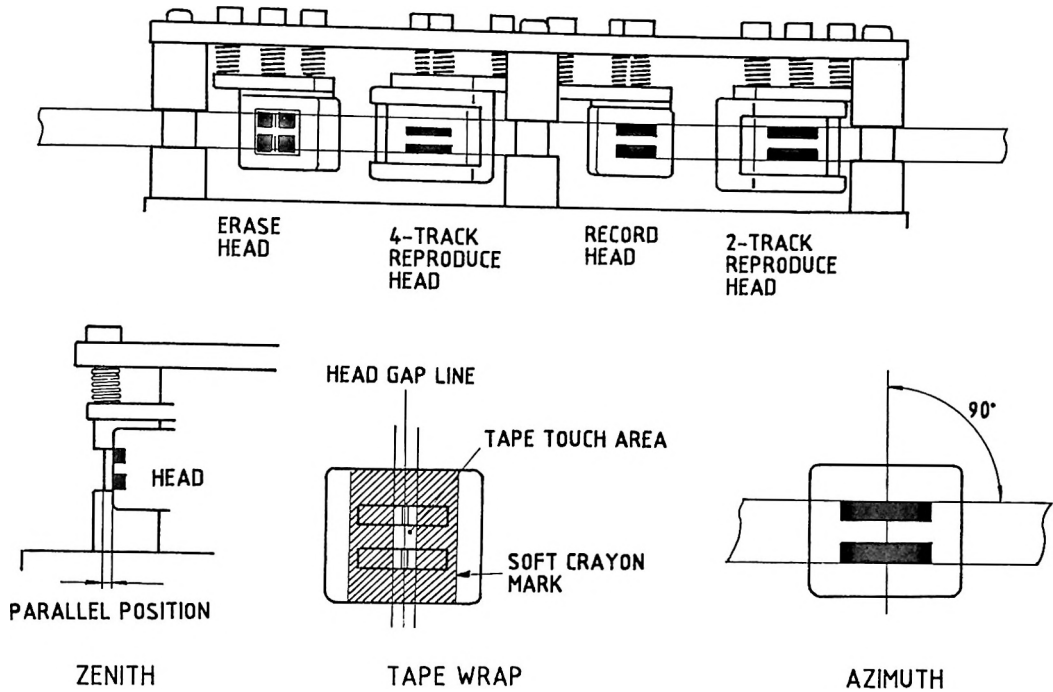

Fig. 5-7

- (5) Then paint the head face with a soft crayon or marking pen, run the tape for about ten seconds, and check the trace of the tape. If head adjustment is correct, the shape of tape touch area on the head should be rectangular and should be equal shape to the head gap line as illustrated Fig. 5-7.
- (6) To have those results, adjust and check the zenith, tape wrap and azimuth of the head with five screws as explained on the Table 5-2.

Table 5-2

Height Adjustment	"A", "T" and "H"	Turn the screws by same amount.
Zenith	"T" or "H"	Check the height at the same time.
Azimuth	"A"	Refer to 5.5.3.
Tape wrap	"W"	Loose both screws, and twist the head. Then tighten the screw again.

(7) Through steps (1) to (7), head mounting is roughly adjusted. Following adjustments are necessary whenever the head or head assembly is replaced. So refer to next 5.5.3 for further fine adjustment with a test tape and a blank tape.

1. Reproduce head replacement
 - A. Reproduce EQ adjustment
 - B. SRL adjustment
2. Record head replacement
 - A. Record bias adjustment
 - B. Overall frequency response adjustment
 - C. Record level adjustment
3. Erase head replacement
 - Erase current measuring

5.5.3 REPRODUCE EQUALIZATION ADJUSTMENT

- (1) Prepare the tape deck for reproducing the test tape as instructed in Table 5-3. Thread low speed test tape first. Head azimuth adjustment should be done at lower speed of the machine.

Table 5-3

Switch	Switch Position	Note
RECORD SELECTOR	OFF	
SEL-REPRO	OFF	
MONITOR	TAPE	both channel
REF FLUX	MID	for 250 nwb/m test tape
EQUALIZATION	NAB	or IEC
SRL SWITCH	ON (SRL)	
OUTPUT LEVEL	HIGH	for +4 dBm OUTPUT
TAPE SPEED	LOW	

- (2) Put the tape deck in PLAY mode and reproduce reference level section of the test tape and adjust VR106 (SRL LEVEL) to read 0 VU on the VU meter.
- (3) Observe the line output with a dual trace oscilloscope during reproducing 10 kHz or higher frequency section of

the tape. Adjust A4 screw to have correct phase shift as illustrated below.

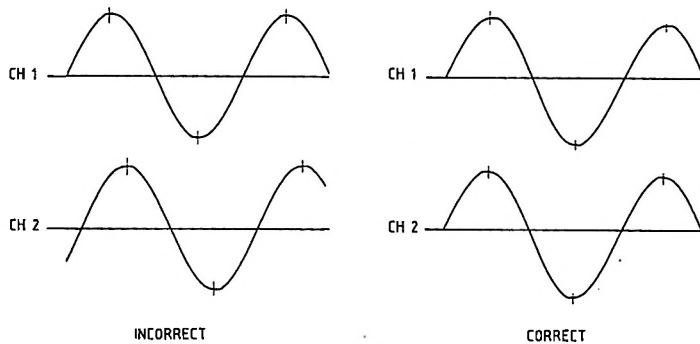

Fig. 5-8

- (4) When correct phase shift adjustment has been done, then adjust VR103 to have flat frequency response. After this adjustment, reproduce reference level section again and check if 0VU adjustment held at step (2) is drifted or not. If drifted adjust VR106 again.
- (5) Do the same steps (3) and (4) at higher speed with high-speed test tape.

5.5.4 BIAS ADJUSTMENT

Figure 5-9 shows the variation of the frequency response by the bias set and the Record EQ adjustment control, and Fig. 5-10 shows the characteristics of the output and distortion vs. bias current.

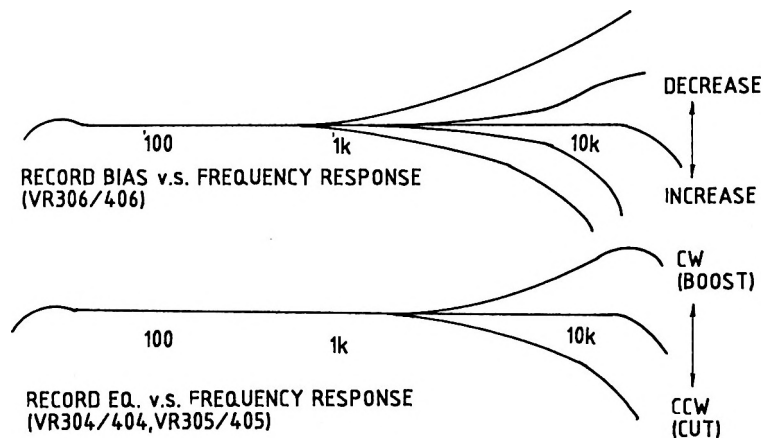

Fig. 5-9

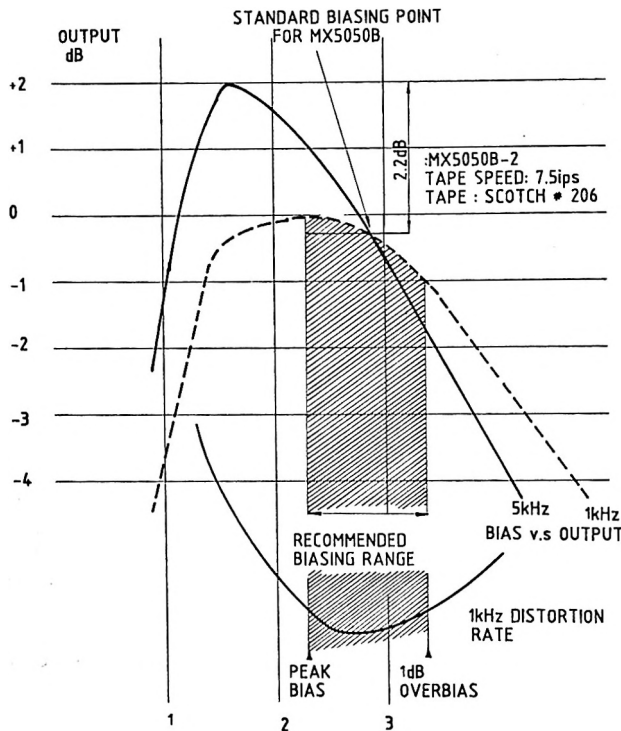

Fig. 5-10

The amount of the bias current relates to the distortion and the overall frequency response. So overall frequency response may be adjusted with both the record EQ and the bias current adjustment for a flat frequency response. Normally record bias should be set between the peak bias and some amount of over bias at 1 kHz for lower distortion and high maximum output.

- (1) Feed 1 kHz, 0 dBm signal to input of the recorder. Monitor the input and adjust input level control knob to read 0 VU on the VU meter. Then set the MONITOR switch to the TAPE position. Select SRL position of the SRL switch.
- (2) Put the machine in RECORD mode at 15 ips.
- (3) Turn down (counterclockwise) the bias control potentiometer once and gradually turn it up clockwise. The VU meter reading will increase. Find out the peak point of the output level as explained with Fig. 5-10.
- (4) Feed 10 kHz signal and adjust screw A3 to have same phase relation as explained previously at reproduce head adjustment.

- (5) When head adjustment has been completed, adjust VR303 (L ch in 15 ips) to have 0 VU reading on the VU meter.
- (6) Change input signal frequency from 30 Hz to 20 kHz and check if frequency response is within specification. Adjust Record EQ pot and bias if necessary.
- (7) Do the same steps for the record frequency response at lower tape speed. In this case input signal level should turn down by 10 dB, so recording should be held at -10 VU output.

5.5.5 RECORD LEVEL, MONITOR LEVEL ADJUSTMENT

- (1) Set SRL select switch to SRL.
- (2) Feed -15 dBm, 1 kHz sine-wave signal to input. Turn the input level control knob all the way up.
- (3) Put the machine into Record mode and monitor off the tape.
- (4) Adjust VR305 to have 0 VU reading on the VU meter.
- (5) Then select the "SOURCE" position of the monitor switch.
- (6) Adjust VR108 to have 0 VU reading.

5.5.6 PEAK INDICATOR TRIGGER LEVEL ADJUSTMENT

Peak indicators are triggered at the recorded flux level of 520 nWb/m. This point is 9 dB above 185 nWb/m (RECORD LEVEL switch in "L" position), 6.4 dB above 250 nWb/m (RECORD LEVEL switch in "M" position), and 5.2 dB above 320 nWb/m (RECORD LEVEL switch in "H" position as shown in Fig. 5-11.

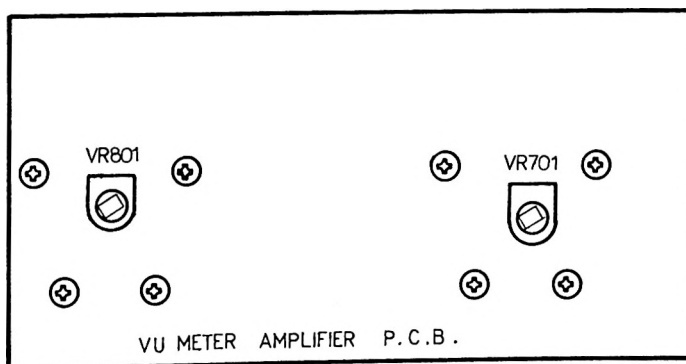

Fig. 5-11 VU Meter Amplifier P.C.B.

For peak indicator trigger level adjustment, proceed as follows:

- (1) Set the RECORD switch to the "L" position, connect the audio oscillator to the LINE INPUT terminals, and feed a 0 dBm signal.
- (2) Set the MONITOR switch to the SOURCE position and adjust the LINE INPUT controls for a 0 dB indication on the VU meter.
- (3) Shift the feeding level of the audio oscillator to +9 dBm.
- (4) Turn the VR701/801 adjustment controls on the VU meter amplifier P.C.B. fully counterclockwise and then clockwise until each peak indicator in the VU meter illuminates.

SECTION VI
TAPE TRANSPORT MAINTENANCE AND REPLACEMENT PROCEDURE

Tape transport maintenance includes procedures for adjusting the supply and take-up reel brakes, the capstan pinch roller pressure and the capstan speed adjustment.

6.1 TRANSPORT ACCESS

To access to the recorder transport, proceed as follows:

- (1) Remove the power cable and place the recorder in an upright position.
- (2) Remove the rear cover by removing the six cross-recessed screws on the panel (two screws are with studs).
- (3) Open the control printed circuit board by removing six cross-recessed screws marked "OPEN".

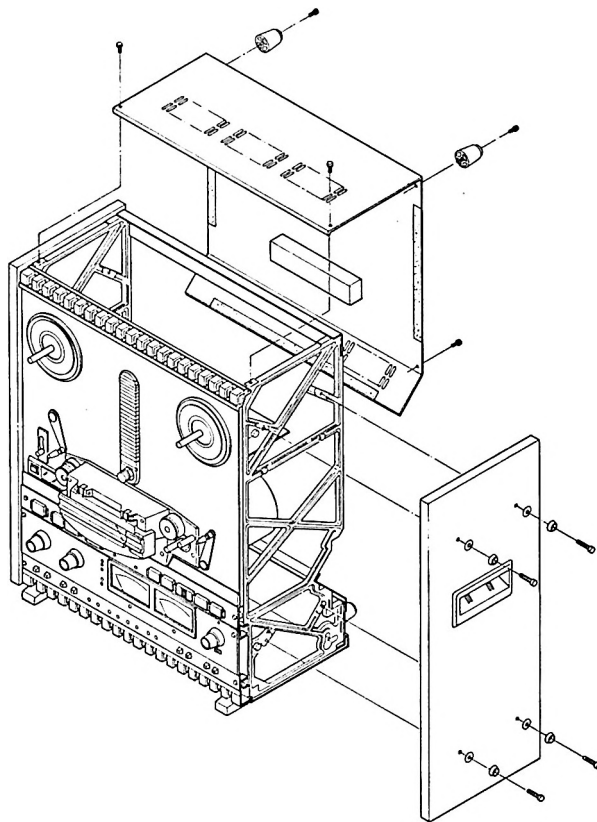

Fig. 6-1 Rear Panel and Side Board Removal

- (4) Remove the two side panels by removing the four hex-socket screws on each panel.

6.2 BRAKE ADJUSTMENT

The brake system on each reel stops reel rotation when the stop mode is entered into or when power is removed. The brakes are checked and adjusted with the power removed. Since the brake force is different for each direction of rotation (brake differential), and there is a single adjustment, the force is checked and adjusted for the best compromise force in each direction.

In the following steps, an empty 10¹/₂ inch diameter NAB reel (4¹/₂ inch diameter hub) is used with string wrapped on the reel. A spring scale is attached to a small loop formed in the free end of the string.

If 10¹/₂ inch diameter NAB reel (4¹/₂ inch diameter hub) is not available, a 7 inch diameter reel (2¹/₄ inch diameter hub) may be used but all readings must be multiplied by a factor of 2.

Proceed as follows:

Refer to Table 6-1 for the breaking force specifications.

- (1) Place an empty 10¹/₂ inch diameter NAB reel on the supply reel turntable. Secure with a hold-down knob.
- (2) Wind string by few turns counterclockwise on the hub. Tie a loop in the free end of the string.
- (3) Insert the hook of a 0-16 ounce or 0-32 ounce spring scale through the loop and hold the spring scale upright as shown in Fig. 6-2.
- (4) Pull on the scale slowly to make the reel rotate counterclockwise (direction "B" in Fig. 6-2). While being sure the string does not rub against either flange, note the scale reading. The reading should be 7.9 to 9.7 ounces (225 to 275 grams).
- (5) Wind the string in a clockwise direction on the supply reel.
- (6) Repeat steps (3) and (4) to make the reel rotate clockwise (direction "A" in Fig. 6-2). The reading should be 3.6 to 4.5 ounces (100 to 125 grams).
- (7) If the readings were low in both directions, remove the brake spring (shown in Fig. 6-3) from the existing anchor hole on the brake lever and install the spring in the next hole located farther away from the brake solenoid.
- (8) If the readings were high in both directions, move the spring anchor point closer to the brake solenoid.

- (9) If the brake spring was moved, repeat steps (2) through (6) to check the results.
- (10) Repeat the brake adjustment procedure on the take-up reel. Note that a high braking force is present when the take-up reel is rotated clockwise. The braking force specifications are the same as for the supply reel.

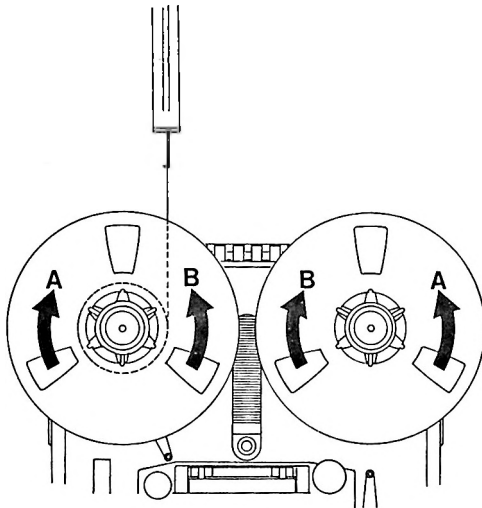

Table 6-2 Braking Force Specifications

A	3.6 to 4.5 ounces (100 to 125 grams)
B	7.9 to 9.7 ounces (225 to 275 grams)

Fig. 6-2 Brake Measurement

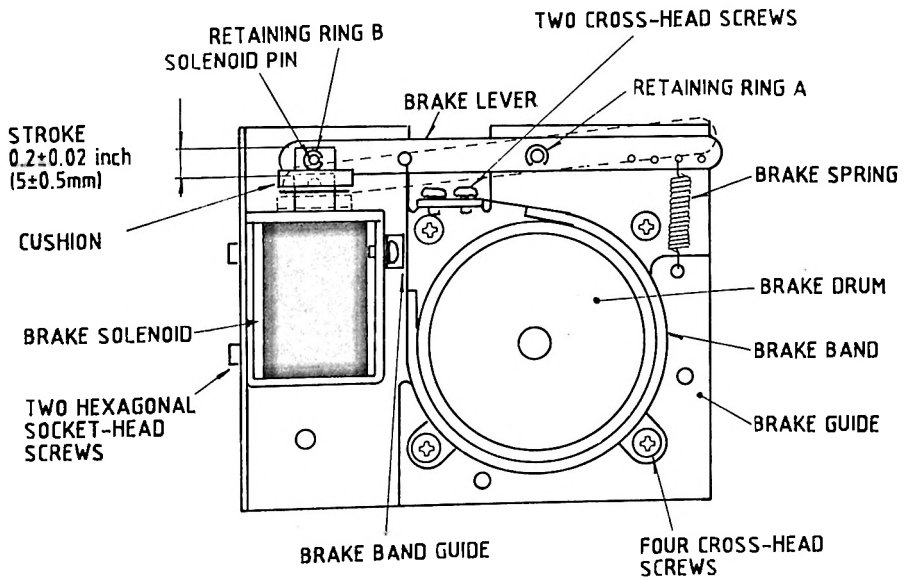

Fig. 6-3 Brake Assembly Location

6.3 CAPSTAN PINCH ROLLER PRESSURE ADJUSTMENT

The capstan pinch roller's pressure against the capstan is determined by the capstan solenoid spring. This force is adjusted by means of the nut shown in Fig. 6-5. The nut is adjusted to obtain a force of 6.4 ~ 7.0 pounds. The resistance of the solenoid coil rises with the temperature and causes the solenoid's force to decrease. Therefore, do not adjust the pinch roller's pressure until the recorder has been operated in the play mode for at least 30 minutes. The following procedure should be adhered to.

- (1) Use adhesive tape to hold the takeup-tension-arm safety switch in an upright position so that the safety switch is not activated.
- (2) Tie string together to form a continuous loop. Place one end of the loop around the capstan pinch roller shaft.
- (3) Press the PLAY push-button. The pinch roller will move to make contact with the capstan and both will rotate.
- (4) Hook a 0 to 10 pound spring scale to the other end of the cord and pull the cord taut, straight to the center of the capstan as is shown in Fig. 6-4. Do not let the cord come into contact with the rotating pinch roller.

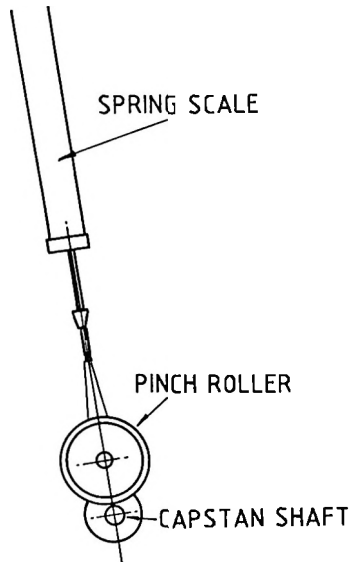

Fig. 6-4 Pinch Roller Pressure Measurement

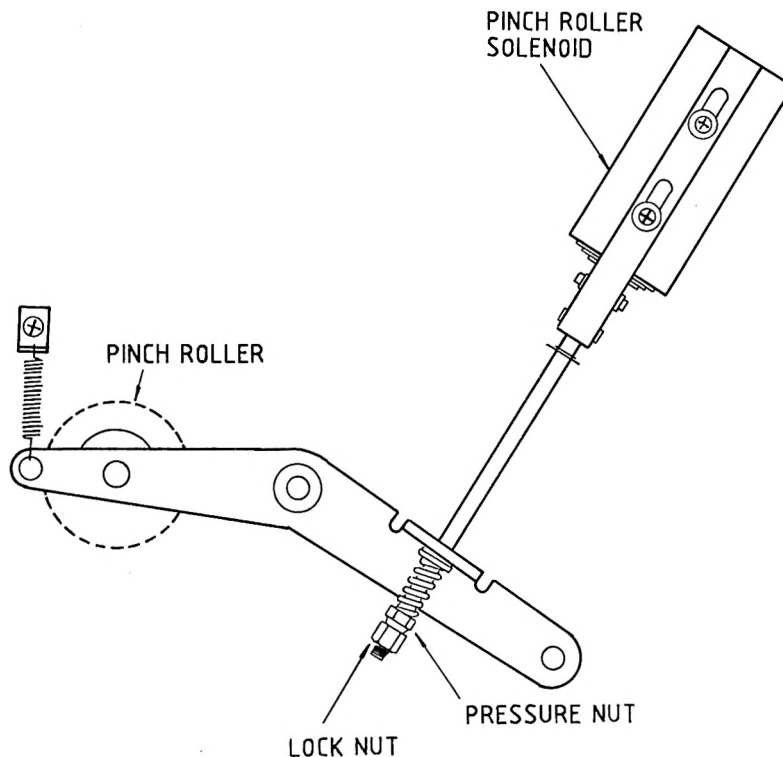

Fig. 6-5 Pinch Roller Pressure Adjustment

- (5) Pull on the scale and note the scale reading when the pinch roller just loses contact to the capstan (the pinch roller stops rotating). The scale reading should be 6.4 ~ 7.0 pounds.
- (6) If a proper scale reading was not obtained in step (5), loosen the locknut and adjust the pressure nut as required. (Turning the pressure nut towards the spring increases pinch roller pressure.) Tighten the locknut.
- (7) After adjustment has been completed, check that the solenoid bottoms within the solenoid coil (the pinch roller can easily be pushed away from capstan). If the solenoid does not bottom, loosen the locknut and turn the pressure nut away from the spring until the solenoid bottoms. Recheck the pressure adjustment and tighten the locknut.

6.4 SPEED CONVERSION AND SPEED ADJUSTMENT

The MX-5050BII series units can be operated at 3 tape speeds. The "high" setting is for 15 and $7\frac{1}{2}$ ips, and the "low" setting is for $7\frac{1}{2}$ and $3\frac{3}{4}$ ips. The conversion procedure requires only that you switch the speed selection switch and adjust the tape speed.

We also recommend that you re-adjust the amplifier to obtain optimum performance.

- (1) Remove the 6 screws attaching the rear panel to the tape deck. Remove the panel.
- (2) Remove the 4 allen screws that hold the right side panel to the frame. Remove the panel.
- (3) The speed selection switch is located on the big P.C.B. Ass'y as illustrated Fig. 6.6.
- (4) Slide the switch to L for $7\frac{1}{2}$ and $3\frac{3}{4}$ or H for 15 and $7\frac{1}{2}$ ips.
- (5) Put a speed reference tape for the speed selected on the transport.
- (6) Play the tape and measure the frequency of the output signal with a frequency counter.
- (7) Adjust the appropriate pot on the servo P.C.B. Ass'y near the capstan motor, as illustrated Fig. 6-7, to obtain the reference speed frequency.
- (8) Re-install the side and rear panels.

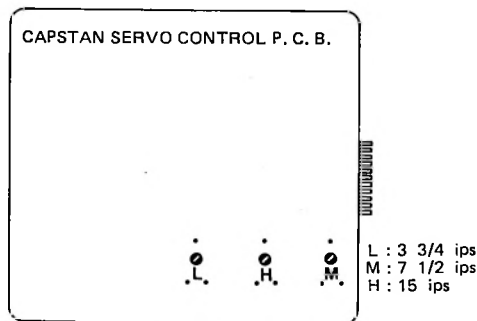
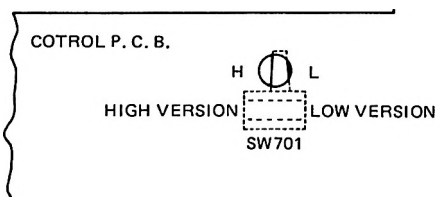

Fig. 6-6 Location of Tape Speed Conversion Switch

Fig. 6-7 Capstan Servo Control P.C.B.

6.5 REEL MOTOR ASSEMBLY REPLACEMENT

6.5.1 REEL TABLE HEIGHT ADJUSTMENT AND REPLACEMENT

The reel table may be removed by removing the three cross-head screws accessible from the front of the transport. To adjust the reel table height, loosen the two hexagonal socket-head screws shown in Fig. 6-8, adjust the height and retighten the screws.

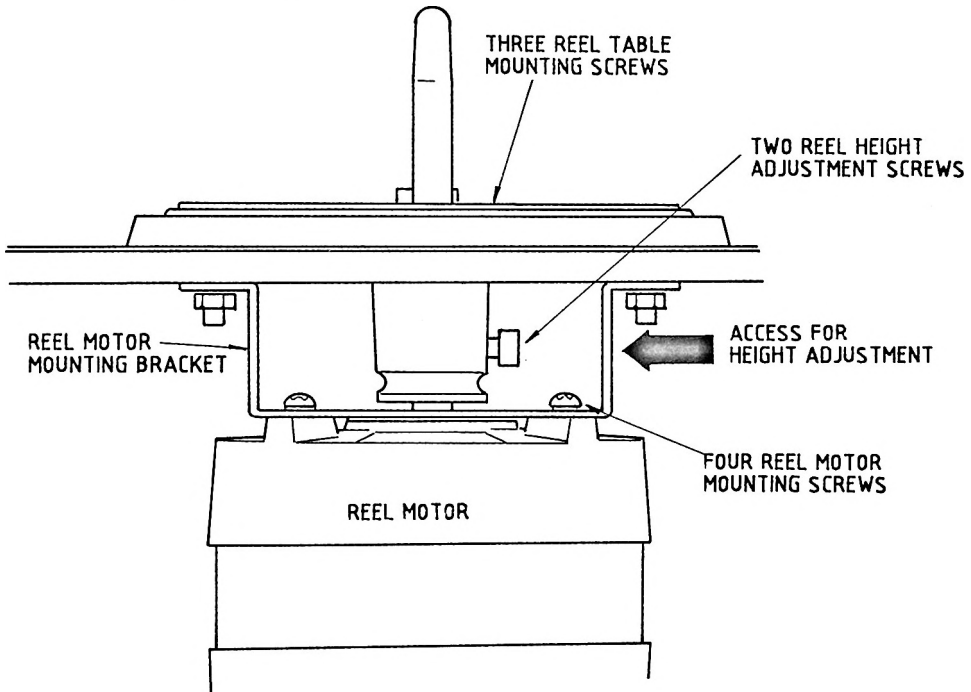

Fig. 6-8 Reel Motor Mounting

6.5.2 REEL MOTOR REPLACEMENT

To replace the supply or takeup motor proceed as follows:

- (1) Loosen the two hexagonal socket-head screws on the reel shaft holder (Fig. 6-8) and remove the reel table and holder.
- (2) Tag and unsolder the motor leads attached to the printed circuit board.

- (3) Remove the four motor mounting cross-head screws, accessible from the front of the transport.
- (4) Remove two capscrews holding brake drum on to the reel motor shaft and take out the brake drum.
- (5) Remove the brake assembly by removing the four brake assembly mounting screws on the bottom of the reel motor as shown in Fig. 6-9.

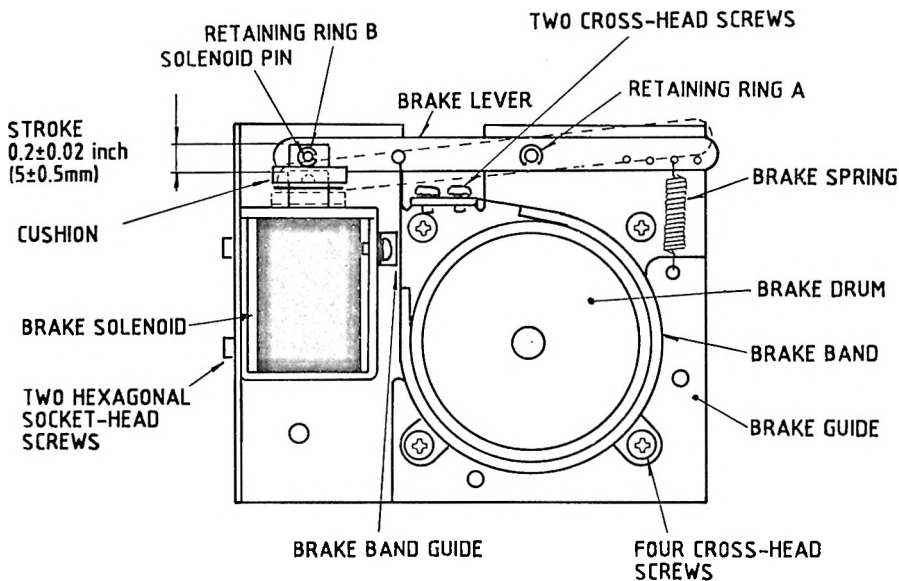

Fig. 6-9 Brake Assembly

6.5.3 BRAKE BAND AND SOLENOID REPLACEMENT

When a new brake band or new brake solenoid is installed (Fig. 6-9), it is necessary to position the brake guide and/or brake solenoid to ensure that is uniform brake band clearance around the brake drum when the solenoid is energized.

Also, the brake solenoid plunger must bottom in the solenoid housing when the solenoid is energized.

When the solenoid is de-energized, the brake band should uniformly contact the drum surface.

After installation, perform the brake adjustment procedure in page 6-3 of this manual.

After completion of the adjustments, place the recorder in the play mode for 30 minutes.

Then press the STOP and PLAY push-buttons to ensure that the solenoid bottoms when it is hot.

To replace the brake band, proceed as follows:

The brake band is replaced together with the brake lever as assembly.

- (1) Remove the retaining ring "A" and "B", and remove the brake spring.
- (2) Remove the two cross-head screws, and replace the brake band and brake lever.

To replace the brake solenoid, proceed as follows:

- (1) Remove the brake spring.
- (2) Remove retaining ring B on the solenoid pin and remove the solenoid pin.
- (3) Remove the solenoid housing and plunger by removing the two hexagonal socket screws.
- (4) Install a new solenoid housing and plunger and adjust the solenoid for 0.2 ± 0.02 inch plunger stroke by loosening two hexagonal socket-head screws.

6.6 POWER TRANSFORMER REPLACEMENT

To replace the power transformer (refer to EXPLODED VIEW 3), proceed as follows:

- (1) Tag and unsolder all transformer leads.
- (2) Remove the four M4 nuts that secure the transformer to the transport.
- (3) Install a new transformer in the reverse order of removal, and resolder the leads to the terminals on the transformer.

6.7 CAPSTAN MOTOR REPLACEMENT

The capstan motor should be replaced along with the servo control printed circuit board assembly. To replace the capstan motor proceed as follows:

- (1) Remove the pinch roller cap by turning the cross-head screw counterclockwise.
- (2) Remove the pinch roller from the pinch roller shaft.
- (3) Remove two screws attaching the head housing cover to the tape deck. Remove the head housing cover.
- (4) Remove three screws that hold the lower head cover (skirt) to the deck panel. Remove the cover.

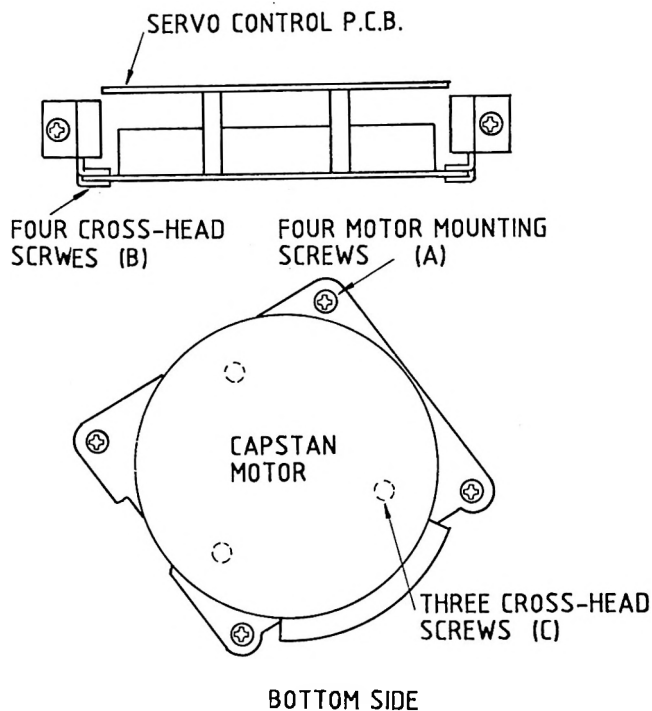

Fig. 6-10 Location of DC Servo Capstan Motor

- (5) Remove the metal dust cap from the capstan shaft by turning it counterclockwise.
- (6) Remove the connector on the servo control printed circuit board assembly located above the capstan.
- (7) Remove the servo control printed circuit board assembly and its mounting plate by turning the four M3 cross-head screws (B) on the mounting plate.
- (8) Remove the capstan mounting plate and capstan motor by removing the four M4 cross-head screws (A) on the mounting plate.
- (9) Remove the capstan motor by removing the three M4 cross-head screws (C) on the mounting plate and install a new capstan assembly in the reverse order of removal.

6.8 PINCH ROLLER REPLACEMENT

To replace the pinch roller assembly proceed as follows:

- (1) Remove the pinch roller cap by removing the screw on it.

NOTE: There are polyslider washers on both sides of the pinch roller.

- (2) Install a new pinch roller, the polyslider washers, and pinch roller cap in the reverse order.

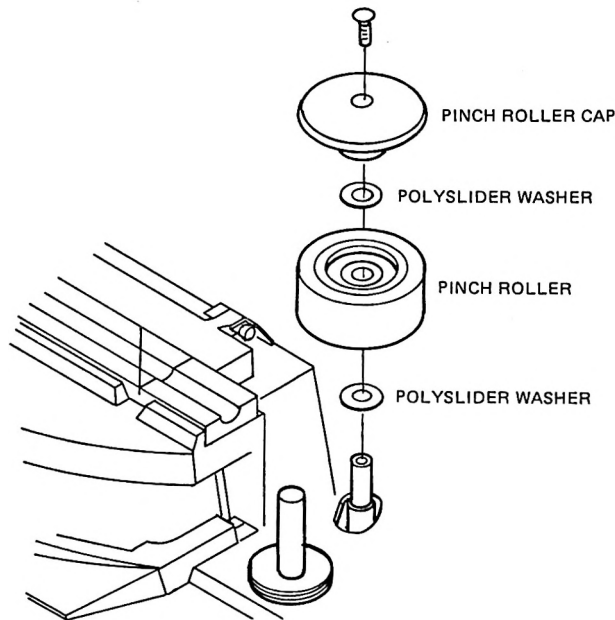

Fig. 6-11 Pinch Roller Removal

6.9 HEAD ASSEMBLY REPLACEMENT

This section provides a description of the head assembly, the procedure for changing the head stack, and the adjustment procedure for adjusting head azimuth (tilt), head height, head zenith (perpendicularity), and tape wrap (racking).

These adjustments are required whenever a head stack is replaced.

6.9.1 DESCRIPTION

The head assembly is mounted on three tape-guide posts and secured in place by the three screws labeled "M" in Fig. 6-12. The insulating shield for the head assembly printed circuit board is secured by the screws labeled "S".

Each head stack is secured to a bracket by the screws labeled "W" with a spacer between the bracket and the head stack. Each bracket is suspended from the head base by the three spring-

loaded screws labeled "H", "A", and "T". Screws labeled "W" are used to adjust tape wrap. Screws labeled "H", "A", and "T" are used to adjust height, azimuth, and zenith.

A head stack may be removed and re-lapped (face resurfaced) if the amount of wear is small and only an indication of poor head-to-tape contact is evident.

Poor contact is the result of improper adjustment and is evidenced by loss of high frequency response of the record or reproduce head stack, difficulty in achieving bias peak (record stack), and insufficient erase stack erasure.

6.9.2 HEAD STACK REPLACEMENT

To change a head stack, proceed as follows:

- (1) Remove the AC power cord and lift the head cover.
- (2) Remove the three screws labeled "M" and pull the head assembly out from the head connector.
- (3) Tag and unsolder (use a low wattage pencil type iron to prevent damage) the leads at the rear terminal of the head stack.
- (4) Remove the head stack by removing the two screws labeled "A", "T", and "H".
- (5) Install a new head stack and solder the leads.
- (6) As a preliminary adjustment, measure the distance between the head base and the bracket at a point near spring-loaded screws "A", "T", and "H".
If necessary adjust the screws for equal spacing.
- (7) Paint the head face with a soft crayon, run the tape for about ten seconds, and check the crayon rubbed away by the tape. If tape wrap is incorrect, adjust the wrap by loosening the screws labeled "W" as shown in Fig. 6-12.

Head alignment and the following adjustments are necessary whenever the head is replaced.

- 1) In the case of reproduce head replacement
 - A. Reproduce equalization adjustment
 - B. SRL adjustment
- 2) In the case of record head replacement
 - A. Record bias adjustment
 - B. Overall frequency response adjustment
 - C. Record level adjustment

3) In the case of erase head replacement

A. Record bias adjustment

(8) Refer to previous section, Section V for more details on those adjustments.

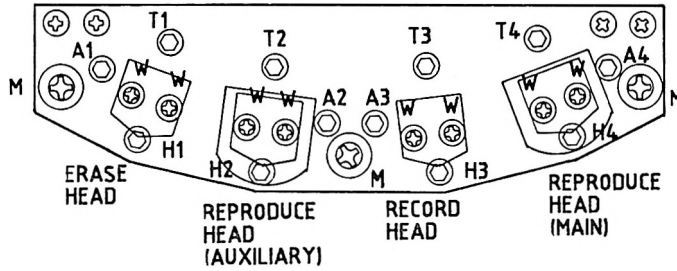

Fig. 6-12 Head Assembly

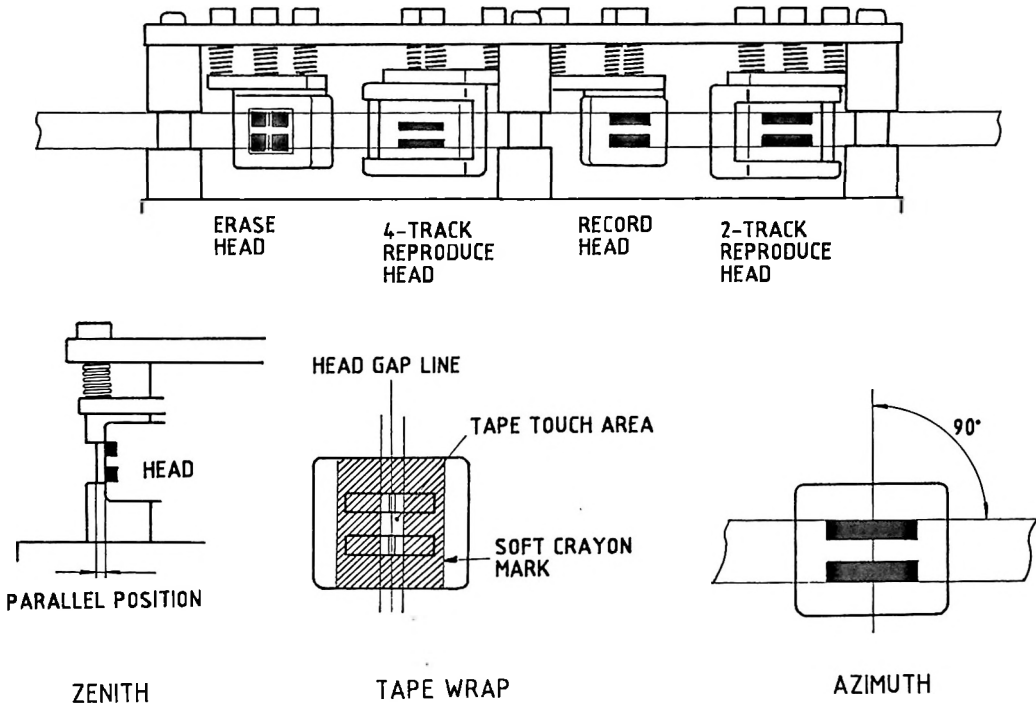

Fig. 6-13 Head Alignment

SECTION VII. PERFORMANCE TESTING

Performance testing should be made at regularly scheduled intervals (every 150 hours or every month) to ensure that the recorder is performing within specifications. These tests should also be performed whenever the recorder appears to be malfunctioning and following repairs to the equipment that may affect performance.

If the performance test is not successful, proceed to the applicable electronic and mechanic alignment procedure. Refer to previous sections for alignment.

This section provides general test methods for a tape recorder, but space is not enough to describe on all of methods. So please refer to any other published books. Also talk to OTARI or OTARI representative.

7.1 GENERAL NOTICE

It is important to clean and demagnetize the head and tape guiding components before performing the test and alignment procedures. The voltages indicated in this section are for the MX-5050BII-2 model and are at a 1 kHz frequency at reference recording level of 250 nWb/m (The RECORD LEVEL switch on the back panel is in the 'M' position). In the case of IEC equalization, the reference record level is 320 nWb/m (RECORD LEVEL switch is in the 'H' position) that is 1.2 dB above 250 nWb/m. The test equipment listed in Table 4-1 is required for completion of the performance and alignment procedures.

7.2 TEST TAPES

Test tapes are precisely recorded under controlled conditions and must be correctly handled and stored to retain accuracy. Handle the test tapes as follows:

- (1) Clean and demagnetize the head and tape guiding components before installing the test tape.
- (2) Never store test tapes in areas where there are temperature or humid extremes.
- (3) Never run the test tapes on speeds other than a normal play run (never use the rewind or fast forward mode). This is further explained below.

During the alignment procedure, the rewind and fast forward modes should not be used.

After alignment, wind the tape completely on the takeup reel, interchange reels, thread the tape, and place the equipment in the play mode to wind the tape back on its original reel.

After extensive use, high frequency tones may be drop as much as 2 dB. In addition, flutter indication may rise even though actual flutter remains unchanged.

Flutter increase is caused by demagnetization of the recorded signal from repeated plays, tape deformation due to tape tension, changes in temperature and humidity, and increased dropout resulting from tape wear.

7.3 TEST CONDITIONS

The test conditions specified in the following steps are to be met prior to performing the tests. After these test conditions are met, continue with the following procedures for checking overall signal-to-noise, overall distortion, crosstalk, and flutter.

- (1) Clean and demagnetize the heads.
- (2) Use high quality low-noise tape such as Ampex 456, or Scotch 246, 250, or an equivalent, and bulk erase the blank tape.
- (3) Turn the power on and allow the unit to warm up for 20 minutes.
- (4) Be sure the head cover is installed for all tests.

7.4 PERFORMANCE TESTS

Before performance testing, an SRL check, reproduce frequency response check, record level check, source level check, an overall frequency response check, and a SEL. REP level check are necessary. Refer to Section V. AMPLIFIER ADJUSTMENTS, in this manual for checking procedures.

For performance testing, at first proceed as follows.

Demagnetize and clean the heads and all guiding components.

- (1) Set the REEL switch to the appropriate position, and set the EDIT switch to the "out" non-edit position.
- (2) Set the LINE OUT switch to 'H', set each RECORD switch to the appropriate position, set each SEL. REP switch to the "out" position, and set each MONITOR switch to the "out" SOURCE position.
- (3) Thread a reel of bulk-erased tape onto the transport, set the SRL switch to the SRL position, and push the PITCH CONTROL knob to its fixed position.

7.4.1 OVERALL SIGNAL-TO-NOISE RATIO

The overall signal-to-noise test requires an ASA "A" weighted filter for weighted measurement and a noise filter for unweighted measurement to attenuate noise outside of the audible frequency band. The filter may be built into a small aluminum box as is shown in Fig. 7-1.

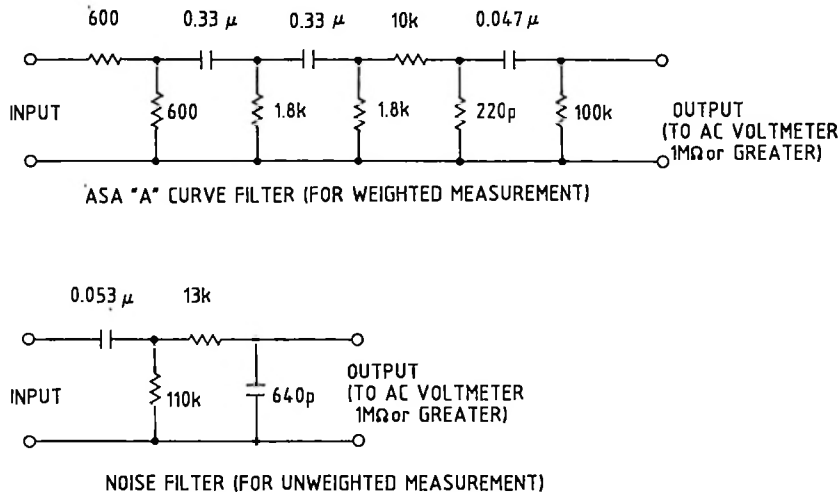

Fig. 7-1 Filter Schematics

The signal-to-noise ratio depends on the SRL calibration, reproduce equalization, bias calibration, and record equalization. Proceed as follows:

- (1) Connect the filter to CH-1 LINE OUT and connect an ac voltmeter to the output of the filter.
- (2) Set the reproduce head selector switch on the head assembly to the appropriate position.
- (3) Set the SRL switch to the "SRL" position and set the RECORD LEVEL switch to the "M" (250 nWb/m) position.
- (4) Hold the TEST OSC push-button depressed and adjust the CH-1 INPUT LINE control for a 0 VU indication on the VU meter. Note the ac voltmeter indication; the ac voltmeter will not read +4 dBm due to the insertion loss of the filter. Release TEST OSC push-button.
- (5) Depress the CH-1 MONITOR switch to the "in" TAPE position, and set the CH-1 INPUT LINE and CH-1 INPUT MIC controls to their full counterclockwise positions. Reset the TAPE TIMER to "0000".

- (6) Start the record mode and record for one minute. Rewind the tape to the "0000" indication on the timer.
- (7) Reproduce the recorded portion and read the noise level on the ac voltmeter.
- (8) The signal-to-noise ratio is determined by calculating the difference in readings obtained in step (2) and step (5) plus 6.4 dB (peak recording level - 520 nWb/m - is 6.4 dB above SRL-250 nWb/m).
- (9) Repeat steps (1) through (6) for the other channels as required, and change the tape speed to check all signal-to-noise ratios.

Table 7-1 Signal-to-Noise Specifications

Tape Speed	1/2 Track		1/4 Track		Full Track	
	Weighted	Unweighted	Weighted	Unweighted	Weighted	Unweighted
15 ips	66/66 dB	64/62 dB	62/62 dB	60/58 dB	68/62 dB	66/60 dB
7 1/2 ips	68/64 dB	66/62 dB	63/62 dB	61/58 dB	68/62 dB	66/60 dB
3 3/4 ips	66/64 dB	64/62 dB	62/62 dB	60/58 dB	66/62 dB	64/60 dB

Note: 65 dB / 63 dB indicates NAB/IEC equalization.

If signal-to-noise specifications are not met, check and adjust the following items.

- 1) SRL calibration
- 2) RECORD BIAS adjustment
- 3) Reproduce equalization
- 4) Record equalization
- 5) Record and/or reproduce electronics
- 6) Head magnetization
- 7) Magnetic flux of a motor, a soldering iron or a transformer near the recorder.

7.4.2 OVERALL DISTORTION TEST

For accurately checking distortion it is necessary to use an audio oscillator with less than 0.1% distortion and a wave analyzer with an adjustable bandwidth capability. A wave analyzer with too narrow bandwidth may make it difficult to measure harmonics due to flutter components within the transport. Instruments that measure total harmonic distortion will be affected by tape and modulation noise in addition to harmonic

distortion. To measure overall harmonic distortion proceed as follows:

- (1) Connect a wave analyzer to CH-1 LINE OUTPUT and connect an audio oscillator to CH-1 LINE INPUT.
- (2) Set the MONITOR switches to their "in" TAPE positions, set the audio oscillator frequency to 1000 Hz, set the SRL switch to the "SRL" position, and set the RECORD LEVEL switch to the "M" (250 nWb/m) position.
- (3) Set the wave analyzer frequency to 1000 Hz, the bandwidth to 100 Hz, and the mode selector switch to AFC.
- (4) Start the record mode and adjust the CH-1 INPUT LINE control for a 0 VU reading on the VU meter.
- (5) Adjust the fine tuning control on the wave analyzer and adjust the analyzer input level control for a full scale reading of 100%.
- (6) Change the wave analyzer tuning control to 2000 Hz and measure the second harmonic content. The second harmonic content should not exceed 0.1%.
- (7) Change the wave analyzer tuning control to 3000 Hz and measure the third harmonic content. Third harmonic distortion is dependent upon the type of tape used, and the accuracy of the RECORD BIAS setting. A typical reading for low noise high output tape is 0.4%.

If distortion specifications are not met, check and adjust the following items.

- 1) SRL calibration
- 2) RECORD BIAS adjustment
- 3) Head magnetization
- 4) Record and/or reproduce electronics

7.4.3 CROSSTALK TEST

It is important that blank or well bulk-erased tape should be used for the crosstalk test. To measure crosstalk between channels proceed as follows:

- (1) Follow the procedure in the Overall Distortion Test, steps (1) through (5).
- (2) Connect a wave analyzer from the output of CH-1 to CH-2 LINE OUTPUT.
- (3) Measure the crosstalk in dB.

crosstalk should not exceed that shown in Table 7-2. If crosstalk specifications are not met, record and reproduce head alignment (height and tape contact) is incorrect or the record or reproduce head is defective.

Table 7-2 Crosstalk Specifications

Track	Crosstalk
1/2 Track	55 dB
1/4 Track	50 dB
1/2 Track DIN	45 dB

7.4.4 ERASURE TEST

It is important that blank tape should be used in the erasure test. To measure depth of erase, proceed as follows:

- (1) Follow the procedure in the Overall Distortion Test, steps (1) through (5). A 1000 Hz signal is being recorded at SRL.
- (2) Set the SRL switch to the off position and adjust the OUTPUT control for a -10 VU reading on the VU meter.
- (3) Adjust the INPUT LINE control for a 0 VU reading on the VU meter, a 1000 Hz signal is being recorded at 10 dB above SRL. Continue recording for a few minutes.
- (4) Disconnect the audio oscillator.
- (5) Rewind and reproduce the recorded section. The VU meter reading should be 0 VU. Check the wave analyzer and readjust it as necessary for a full scale reading of 100%.
- (6) Press the RECORD push-button to place the recorder in the record mode. As the tape is being erased, adjust the percent scale on the wave analyzer to read the residual 1000 Hz tone.
- (7) Repeat the same procedure for the other channels.
- (8) The depth of erase should be more than 75 dB (70 dB for DIN version).

If erasure specifications are not met, check and adjust the following items.

- 1) Erase and/or record head alignment (height, tape contact)

- 2) Erase head wear
- 3) Erase head surface cleanliness
- 4) Bias oscillator adjustment.

7.4.5 TAPE SPEED MEASUREMENT

A flutter test tape is used for measuring tape speed. Since tape tension affects tape speed, it is important for accurate measurement that the flutter test tape used is attached to the end of a full reel of blank tape as shown in Fig. 7-2, and is used with the REEL push-button set to the appropriate reel size. Proceed as follows:

- (1) Place the PITCH CONTROL in the fixed position and set all RECORD switches to their off "out" positions.
- (2) Connect a flutter meter to LINE OUT and set the MONITOR switch to the TAPE position.
- (3) Set the SPEED switch to "HIGH" and use the test tape at its appropriate speed.
- (4) Attach the test tape to a 10-1/2 inch NAB reel as shown in Fig. 7-2, place the test tape on the supply reel table, thread the tape, and set the REEL switch to the LARGE position.
- (5) Place the recorder in the play mode and note the reading on the frequency counter. The reading should be between 2994 and 3006 Hz (3000 Hz \pm 0.2 %).
- (6) Repeat the procedure at a point towards the end of the reel, for a 7 inch EIA reel, and for low tape speeds.
- (7) If adjustment is necessary, refer to Section 6.4.

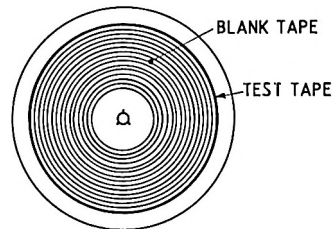

Fig. 7-2 Test Tape Loading

If speed accuracy is not within \pm 0.2%, check and adjust the following items.

- 1) Pinch roller wear and pressure
- 2) Brakeshoe for brake drum contact
- 3) Tape tension
- 4) Power correctness
- 5) Pinch roller and capstan cleanliness
- 6) Servo control circuit for capstan motor
- 7) Capstan motor.

7.4.6 FLUTTER AND WOW TEST

It is recommended that these checks should be made with reference flutter test tapes which are recorded with precise equipment to produce less than 0.03% rms flutter. Flutter meters are sensitive to amplitude modulation that results from poor head-to-tape contact or from signal dropout. Therefore, clean the heads before starting a flutter and wow test.

The following method is used with a test tape:

It is important that the flutter test tape used is attached to the end of a full reel of blank tape as shown in Fig. 7-2, and is used with the REEL push-button set to the appropriate reel size.

- (1) Place the PITCH CONTROL to the fixed position and set all RECORD switches to the off "out" position.
- (2) Connect a flutter meter to the LINE OUT of the inner track channel and its MONITOR switch should be in the TAPE position.
- (3) Set the selector switch of the flutter meter to the NAB weighted position, set the SPEED switch to H1, and use the test tape at an appropriate speed.
- (4) Attach the test tape to a 10-1/2 inch NAB reel as shown in Fig. 7-2, place the test tape on the supply reel table, thread the tape, and set the REEL switch to the H position.
- (5) Place the recorder in the play mode and note the reading on the flutter meter. The reading should be as shown in Table 7-3.
- (6) Repeat the procedure at a point towards the end of the reel, a 7 inch EIA reel, and at low tape speeds.

The following method is used when a test tape is not available:

- (1) Connect the oscillator signal output of the flutter meter to an inner channel (not an edge channel) LINE INPUT of the recorder.
- (2) Connect the same channel's LINE OUTPUT of the recorder to the signal input of the flutter meter.
- (3) Set the SPEED switch to "HIGH", set the SRL switch to the SRL position, set the MONITOR switch to the TAPE position, start the record mode, and adjust the appropriate INPUT LINE control.
- (4) Rewind and reproduce the recorded portion, and note the flutter and wow on the flutter meter.

- (5) Check the flutter and wow at a low tape speed, and check it at a point towards the end of the reel.

Table 7-3 Flutter and Wow Specifications

Tape Speed	Flutter and Wow
15 ips	0.06 %
7.5 ips	0.08 %
3-3/4 ips	0.12 %

Flutter and wow can be caused by any element in the tape path. Excessive flutter and wow may be traced by observing the flutter component on an oscilloscope screen connected to the demodulator output of the flutter meter. If the fluctuation rate observed on the oscilloscope coincides with the rotational elements, such as the supply or takeup reel, capstan or pinch roller, the problem source may be easily traced. Other sources of excessive flutter and wow are:

- 1) Defective capstan servo control
- 2) Damaged capstan motor
- 3) Capstan needs lubrication
- 4) Incorrect tape tension
- 5) Brakeshoe is contacting brake drum.
- 6) Defective tape reels or tape
- 7) Pinch roller is worn or has insufficient pressure, or the pinch roller solenoid is not bottomed.
- 8) Dirty pinch roller and capstan

SECTION VIII
P.C.B. ASSEMBLIES AND PARTS LISTS

The following P.C.B. pattern layout drawings and parts list are provided for service reference. Parts list includes only main parts or the parts difficult to obtain in the field. Also the lists include the parts which should be replaced with the exact same parts supplied by OTARI to maintain the performance. Many diodes, transistors, and ICs are well described in the schematics attached to the machine, so to find out the correct parts number of those parts you need to, refer to the schematics.

PB-16EB REC & PB AMP P.C.B. ASSEMBLY [1]:

<u>No.</u>	<u>Description</u>	<u>Parts No.</u>	<u>Notes</u>
	P.C.B.	PB9A482D	
C521	Capacitor	CGP3103M	0.01 μ F/630V
C318, 418	Capacitor	CGP3182M	0.0018 μ F/630V
C557	Capacitor	C3221147	500V 220pF
	Capacitor	C110013M	Low Leakage 16V 10 μ F
	Capacitor	C110052M	Bi-polar 16V 10 μ F
	Capacitor	C133063M	Bi-polar 25V 33 μ F
	Capacitor	C3101139	Silvered Mica 250V 100pF
	Capacitor	C3330127	Silvered Mica 250V 33pF
	Capacitor	C3470131	Silvered Mica 250V 47pF
L301, 401	Inductor	IN19045	820 μ H
L102, 202	Inductor	IN19072	3.3MH
L101, 201	Inductor	IN19056	6.8MH
L302, 402	Inductor	IN29018	680 μ H
	Heat Sink	KZ1A049	
	Buss Bar	PZ4E003	
VR502	Potentiometer	RV213002	1k Ω
VR104, 204	Potentiometer	RV214005	10k Ω
VR101, 201, 202 102, 103, 203 108, 208	Potentiometer	RV253016	5k Ω
VR306, 406 305, 405	Potentiometer	RV253084	5k Ω
VR501	Potentiometer	RV254003	50k Ω
VR303, 304 403, 404	Potentiometer	RV254085	50k Ω
RL301, 401 501	Relay	RY2DC058	
RL57, 257	Resistor	R8BJ151M	1W 150 Ω
RL84,185,186,187 284,285,286,287	Resistor	R8BJ180M	1W 18 Ω
T501	Oscillator Coil	TF41002A	
SW506, 507 102, 202	Switch	WH12022	TEST OSC TAPE MONITOR
SW301, 302 401, 402	Switch	WH14020	SEL/REP - REPRO REC - READY
SW101, 201	Switch	WH31016	LOW COMP.
SW504	Switch	WH32003	OUTPUT LEVEL
SW502	Switch	WH32020	REC LEVEL
SW503	Switch	WH34014	EQ SELECT
SW501	Switch	WH34019	MIC ATT
		PZ1G091	
		C110165M	Bi-polar 25V 100 μ F
VR106, 206	Potentiometer	RV24B086	SRL 4.7k Ω
VR105, 205	Potentiometer	RV24C087	LOW COMP 47k Ω

PB-16EB REC & PB AMP P.C.B. ASSEMBLY [1]:

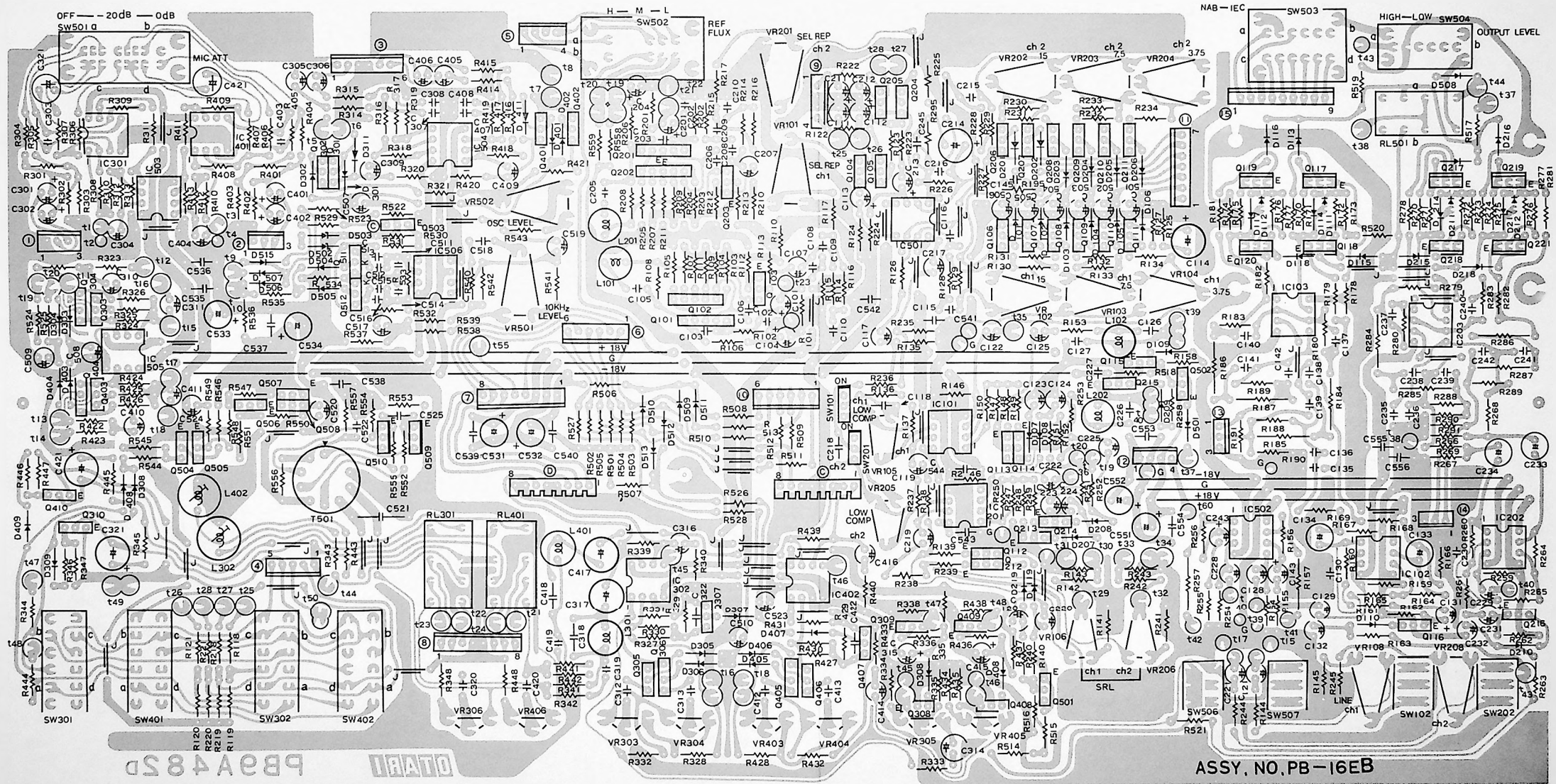

COMP SIDE
ASS'Y NO PB-46Q

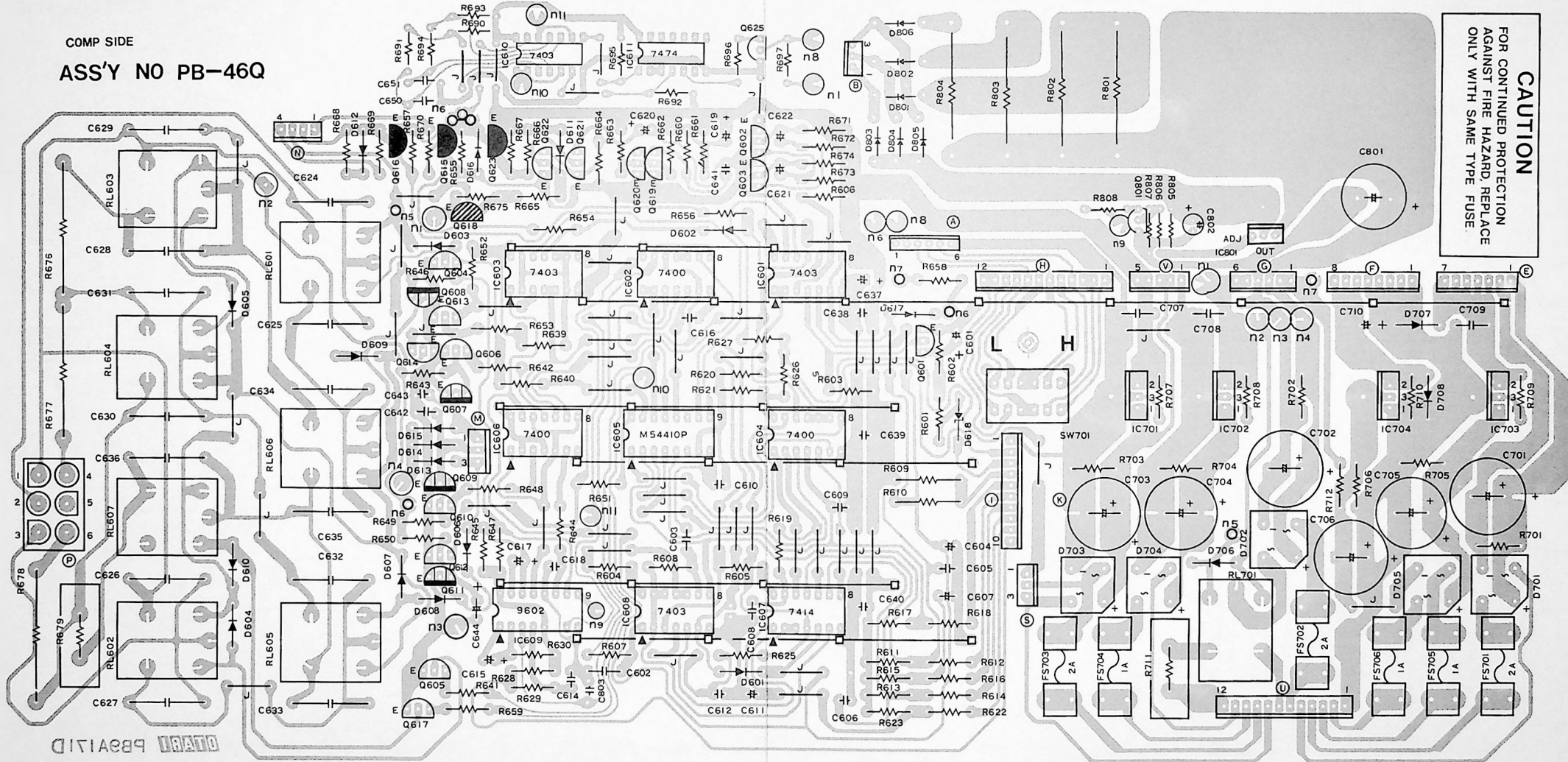

PB-46Q CONTROL P.C.B. ASSEMBLY [2]:

<u>No.</u>	<u>Description</u>	<u>Parts No.</u>	<u>Notes</u>
	P.C.B.	PB9A171D	
C607, 611 621, 622	Capacitor	C11R067M	Bi-polar 50V 1 μ F
C604	Capacitor	C110052M	Bi-polar 16V 10 μ F
C615, 617	Capacitor	C147010M	LOW LC 10V 47 μ F
FS704,705,706	Fuse	FH7F010	125V 1A
FS201,,702,703	Fuse	FH7F020	125V 2A
	Heat Sink	PZ4B015	
	Buss Bar	PZ4E003	
RL601 ~ 7, 701	Relay	RY1DC029	
SW801	Switch	WH34008	SPEED SELECT
R676, 677, 678	Resistor	R8DJ180M	3W 18 Ω
R801, 802	Resistor	R8DJ510M	3W 51 Ω
R803, 804	Resistor	R8DJ560M	3W 56 Ω
R610	Resistor	R1DJ152	1/2W 1.5k Ω
R609	Resistor	R1DJ222	1/2W 2.2k Ω
R679	Resistor	R93-002K	5W 100 Ω
R711	Resistor	R93-003K	5W 1 Ω
D701 ~ 705	Diode	PNS2VB20	
C624 ~ 636	Spark Killer	CZ20001W	0.1 μ F + 120 Ω

SECTION IX
EXPLODED VIEW DRAWINGS AND PARTS LISTS

The followings are the exploded view drawings and parts lists. Parts list titles are followed by a key number which refers to the corresponding exploded view drawing number.

When ordering parts, give a full description, using both the part number and the name of the part. If there seems to be a discrepancy between the drawings herein and your machine, contact OTARI.

OVERALL [1]:

<u>Ref. No.</u>	<u>Description</u>	<u>Parts No.</u>	<u>Notes</u>
1- 1	Reel Ass'y	KW-4J	See 7-21
2	Head Ass'y	KH-41I	See 7-6
3	Pinch Roller Ass'y	KP-4N	See 7-12
4	Tension Ass'y	KA-4Y	See 7-15
5	Capstan Ass'y	KC-4X	See 7-11
6	Control Switch Ass'y	CB-252	See 7-17
7	Side Panel Ass'y	K105601	
8	Rear Cover Ass'y	K106801	
9	Swing Arm Ass'y	KA-4X	See 7-15
10	Roller Ass'y, Tachometer	KI-4J	See 7-15
11	Tape Timer Ass'y	SR-50	See 7-15
12	PCB Ass'y, Amp	A1062	
13	Panel Ass'y, Lower	K106802	
	Panel, Bottom	K102906	
	Bracket	K102909	
	Bracket	K102910	
	Bracket	K102907	
	Foot Bottom	CY4011-A	
	Escutcheon, Ventilation	CY5001A	
14	Foot	CY4013	

OVERALL [1]:

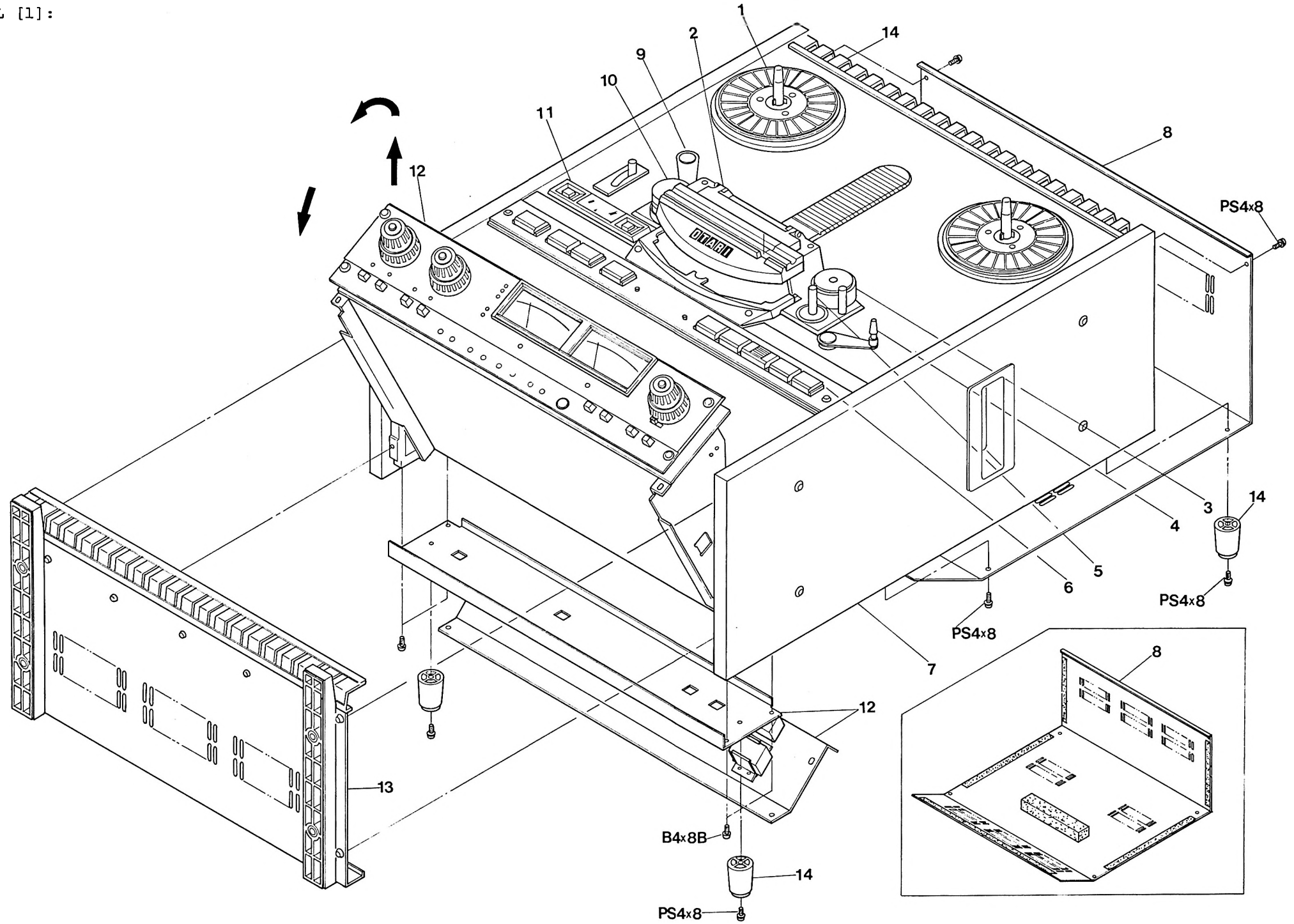

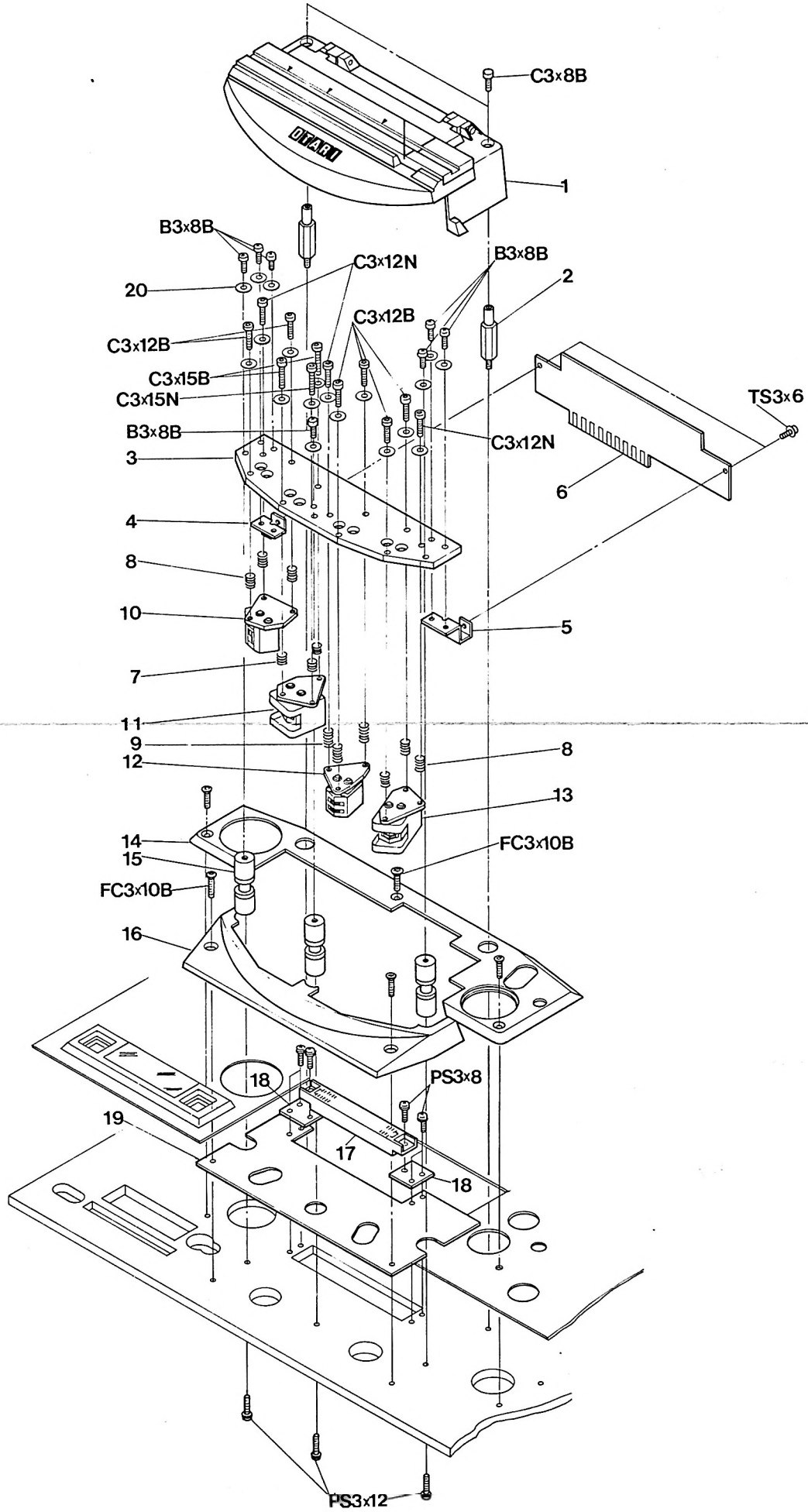

KH-41I HEAD ASSEMBLY [2]:

<u>Ref. No.</u>	<u>Description</u>	<u>Parts No.</u>	<u>Notes</u>	<u>Ref. No.</u>	<u>Description</u>	<u>Parts No.</u>	<u>Notes</u>
2- 1	Head Cover	KH-4Y-A		13	Head Ass'y, Repro (4T)	GH4P069C	NAB 2T 2CH, 4T 2CH, DIN STEREO
2	Stand Off	KH4Y009					
3	Base, Head Ass'y	KH0C047					
4	Bracket, Head PCB	KH41I01			Head, Reproduce Shield, Head	GH4P069- KH0B028-	
5	Bracket, Head PCB	KH41I02			Plate, Mounting	KH0D017-	
6	PCB Ass'y, Head	PB-78I		*	Head Sub Ass'y	KH-41IA	NAB 2T 2CH
7	Spring, Head	GS2019			Head Sub Ass'y	KH-41QA	DIN STEREO
8	Spring, Head	GS2016			Head Sub Ass'y	KH-41TA	NAB 4T 2CH
9	Spring, Head	GS2015			Head Sub Ass'y	KH-41OA	Full Track Mono
10	Head Ass'y, Erase	GH4E082B	NAB 2T 2CH, DIN STEREO	14	Escutcheon, Head Ass'y, Rear	KH0F038	
	Head, Erase	GH4E082-		15	Guide, Tape	KG0D00C	
	Plate, Mounting	KH0D017-		16	Escutcheon, Head Ass'y, Front	KH0F037	
	Head Ass'y, Erase	GH4E058A	NAB 4T 2CH	17	Connector	CN314002	
	Head, Erase	GH4E058-		18	Bracket, Connector	KH4Y004	
	Plate, Mounting	KH0D017-		19	Shield, Head		KH4Y001A
	Head Ass'y, Erase	GH4E012B	Full Track	20	Washer, Polyslide	F524-3	
	Head, Erase	GH4E012-					
	Plate, Mounting	KH0D017-					
	Spacer	KH0D059-					
11	Head Ass'y, Repro (2T)	GH4P027A	NAB 2T 2CH, 4T 2CH				
	Head, Reproduce	GH4P027-					
	Shield, Head	KH0B028-					
	Plate, Mounting	KH0D017-					
	Head Ass'y, Repro	GH4P099C	DIN STEREO				
	Head, Reproduce	GH4P099-					
	Shield, Head	KH0B028-					
	Plate, Mounting	KH0D017-					
	Head Ass'y, Repro	GH4P112C	Full Track				
	Head, Reproduce	GH4P112-					
	Shield, Head	KH0B028-					
	Plate, Mounting	KH0D017-					
12	Head Ass'y, Record	GH4R005B	NAB 2T 2CH				
	Head, Record	GH4R005-					
	Plate, Mounting	KH0D017-					
	Head Ass'y, Record	GH4R100D	DIN STEREO				
	Head, Record	GH4R100A					
	Shield, Head	KH0B028-					
	Plate, Mounting	KH0D017-					
	Head Ass'y, Record	GH4R033B	NAB 4T 2CH				
	Head, Record	GH4R033-					
	Plate, Mounting	KH0D017-					
	Head Ass'y, Record	GH4R111C	Full Track				
	Head, Record	GH4R111-					
	Plate, Mounting	KH0D017-					

T5067 TAPE DECK ASSEMBLY [3]:

<u>Ref. No.</u>	<u>Description</u>	<u>Parts No.</u>	<u>Notes</u>
3- 1	Deck Skin	T5064-A	
2	Guide, Fixed	KG6E003	
3	Deck Plate	T506701	
4	Panel, Transport Control	T506702	
5	Bracket, Transport Control	T506705	
6	Bracket, Deck Plate, Rear	K102911	
7	Transformer, Power	TF11073	
8	Cable Tie	PZ1G053	
9	PCB Ass'y, Edit/Record LED	PB-83E	
10	Cushion	PZ1B051	
11	Cushion	PZ1B052	
12	Bracket, Frame, Rear	T506104	
13	Frame, Side	KZ1A050	
14	Bracket, PCB	T506704	
15	Bracket, PCB	T506703	
16	PCB Ass'y, Control	PB-46Q	
17	Protector Strip, Bracket	PZ1G027	
18	Bracket, PCB	T506706	
19	Bracket	T506711	
20	Bracket	T506710	
21	Cushion	PZ1C031	
22	Shaft	KZ9P160B	
23	Collar	KZ9P030B	
24	Collar	KA6A021	
25	Washer, Nylon	KZ6C011	
26	Spacer	KZ9C060B	
27	Bracket	KZ3A068	
28	Washer, Decoration	KZ6C051	

T5067 TAPE DECK ASSEMBLY [3] :

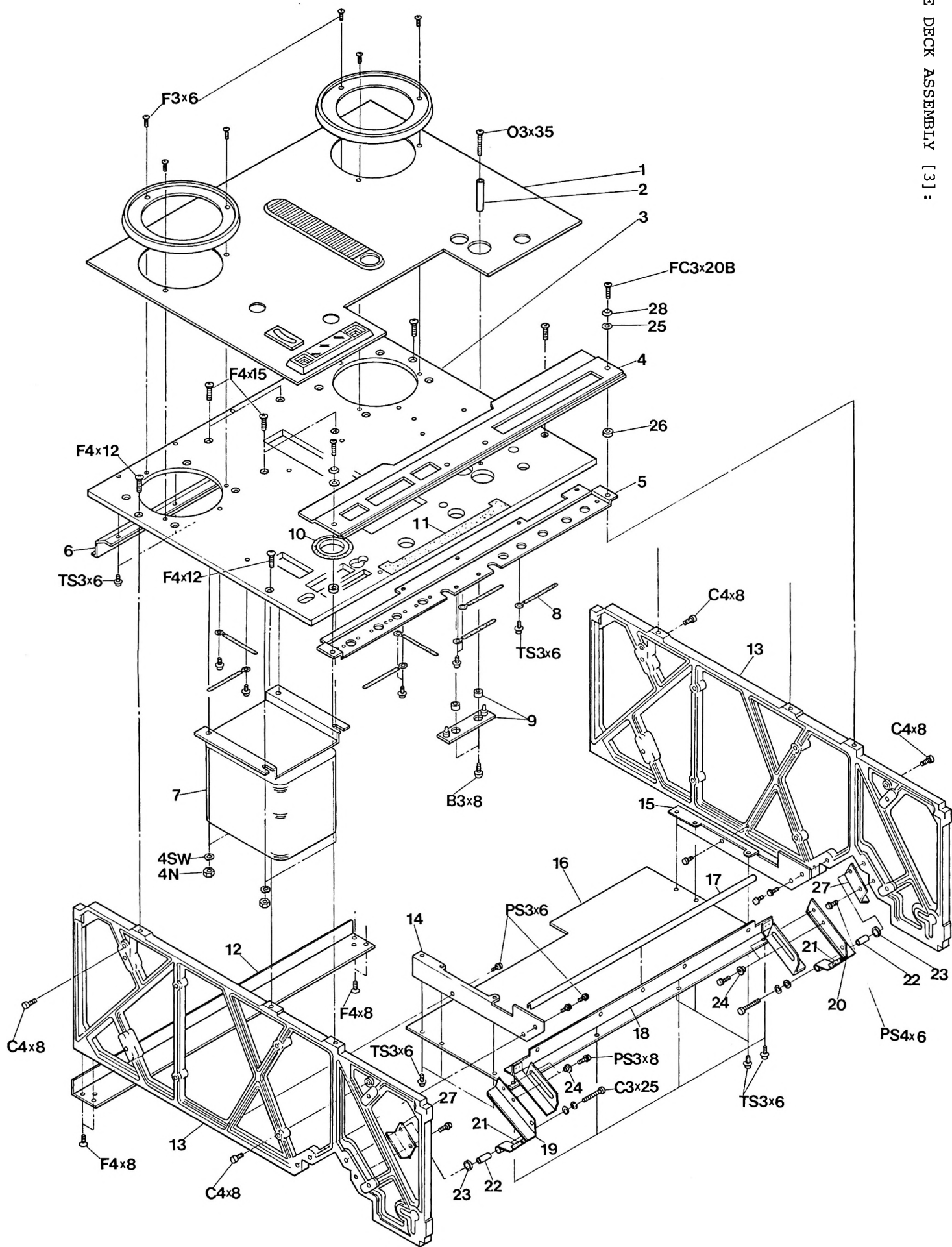

KC-4X CAPSTAN ASSEMBLY [4]:
KP-4N PINCH ROLLER ASSEMBLY [4]:
KP-4L SHIFTER ASSEMBLY [4]:

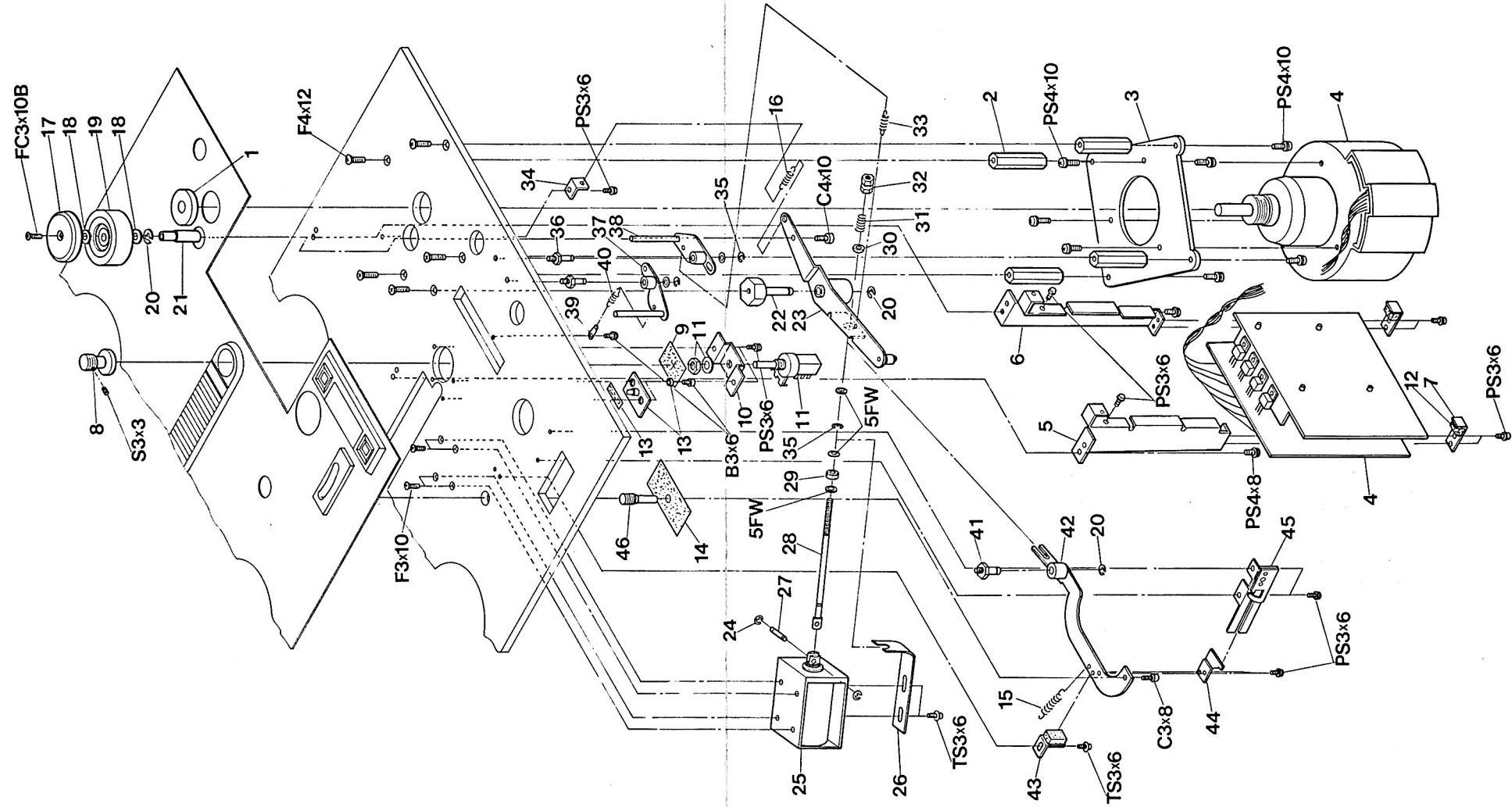

KC-4X CAPSTAN ASSEMBLY [4]:
 KP-4N PINCH ROLLER ASSEMBLY [4]:
 KP-4L LIFTER ASSEMBLY [4]]:

<u>Ref. No.</u>	<u>Description</u>	<u>Parts No.</u>	<u>Notes</u>
4- 1	Cap, Capstan Dust	KCB011A	
2	Stand Off	KZ9I455A	
3	Base, Capstan Motor	KC4H001	
4	Motor, DC Capstan	MR5A021	
5	Bracket, Capstan Drive PCB	KC4X001	
6	Bracket, Capstan Drive PCB	KC4X002	
7	Bracket	KZ3A107	
8	Knob	KN1024A	
9	Cushion, Felt Bracket	PZ1B037	
10	Bracket	KC4H002	
11	Potentiometer	RV252009	
12	Cushion	PZ1C011	
13	PCB Ass'y, Pitch Control LED	PB-83C	
14	Cushion, Felt	PZ1B001	
15	Spring	GS1033	
16	Spring	GS1011	
17	Cap, Pinch Roller	KP0C020	
18	Washer, Polyslide	F523-6	
19	Pinch Roller	KP0A007	
20	Retaining Ring, E-Type	F74TE20	
21	Shaft, Pinch Roller	KP0B010	
22	Shaft, Pinch Roller Arm	KP4L001	
23	Arm, Pinch Roller	KP-4N-A	
24	Retaining Ring, E-Type	F74TE09	
25	Solenoid, Pinch Roller	GP1B10	
26	Stopper, Solenoid Plunger	KZ2A016	
27	Pin, Solenoid Plunger	KZ5A003	
28	Link, Solenoid	KZ6A022	
29	Cushion	PZ1C021	
30	Washer	KP0G004	
31	Spring	GS2003	
32	Nut, Adjustment	F517-4	
33	Spring	GS1028-A	
34	Bracket, Spring Anchor	KZ3A023	
35	Retaining Ring, E-Type	F74TE15	
36	Shaft, Lifter Arm	KR4B001	
37	Lifter, Left	KR0B005	
38	Lifter, Right	KR0B006	
39	Bracket, Spring	CN7B-002	
40	Spring	GS1087	
41	Shaft, Cue Arm	KR4B007	
42	Arm, Lifter	KR4C001	
43	Bracket, Lifter Stopper	KR-4L-A	
44	Cue Arm Catch	KR4C003	
45	Cue Arm Lock	KR-4C-A	
46	Cue Lever	KR4F002A	

KA-4X SWING ARM ASSEMBLY [5]:
 KI-4J TACHOMETER ROLLER ASSEMBLY [5]:
 SR-50 TAPE TIMER ASSEMBLY [5]:

<u>Ref. No.</u>	<u>Description</u>	<u>Parts No.</u>	<u>Notes</u>
5- 1	Cap, Swing Arm	KA0C005	
2	Swing Arm	KA0A017A	
3	Shaft, Swing Arm	KA4J001	
4	Washer, Polyslide	F524-5	
5	Holder, Swing Arm	KA0B008	
6	Guide, Swing Arm	KG4D007	
7	Nut	KZ6D004	
8	Collar	KA0E005	
9	Actuator, Swing Arm	KA-4K-B	
10	Switch	WH51027	
11	Magnet Ass'y, Swing Arm	KA-4K-A	
12	Spring	GS1048	
13	Bracket, Spring	KZ3A024	
14	Collar	KA0E017	
15	Bracket, Stop	KA4X001	
16	Spring	GS1025	
17	Sub Ass'y, Tachometer Roller	KI-4J-A	
	Roller	KI-4J-B	
	Holder	KI0B014	
	Washer	KI0H024	
	Nut, Holder	KI0H025	
	Bearing	BA1Z022	
18	Collar, Tach Disc	KI4F001A	
19	Tach Disc	KI4G003	
20	PCB Ass'y, Direction	PB-82M	
21	Bracket	KI4G002	
22	Cushion	SR5K002	
23	PCB Ass'y, Timer	PB-82L	
24	Knob	KN2067	
25	Cushion, Felt	PZ1B053	
26	Bracket	SR5K001	
27	Switch, Push	WH12149	
28	Bracket	KZ3A106	
29	PCB Ass'y, Timer Drive	PB-46R	

KA-4X TENSION ARM ASSEMBLY [5]:
 KI-4J IMPEDANCE ROLLER ASSEMBLY [5]:
 SR-50 TAPE TIMER ASSEMBLY [5]:

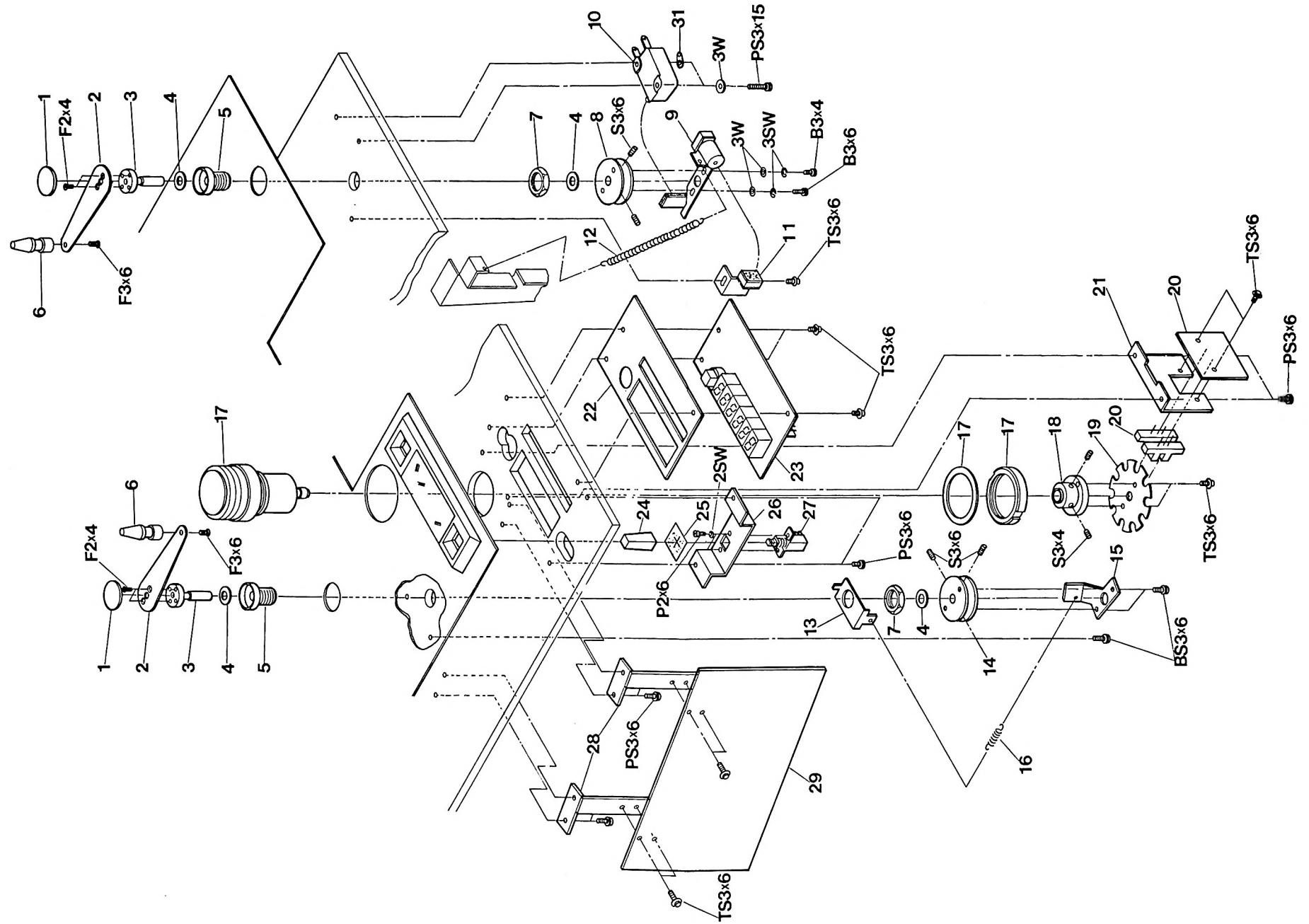

CB-252 CONTROL SWITCH ASSEMBLY [6]:

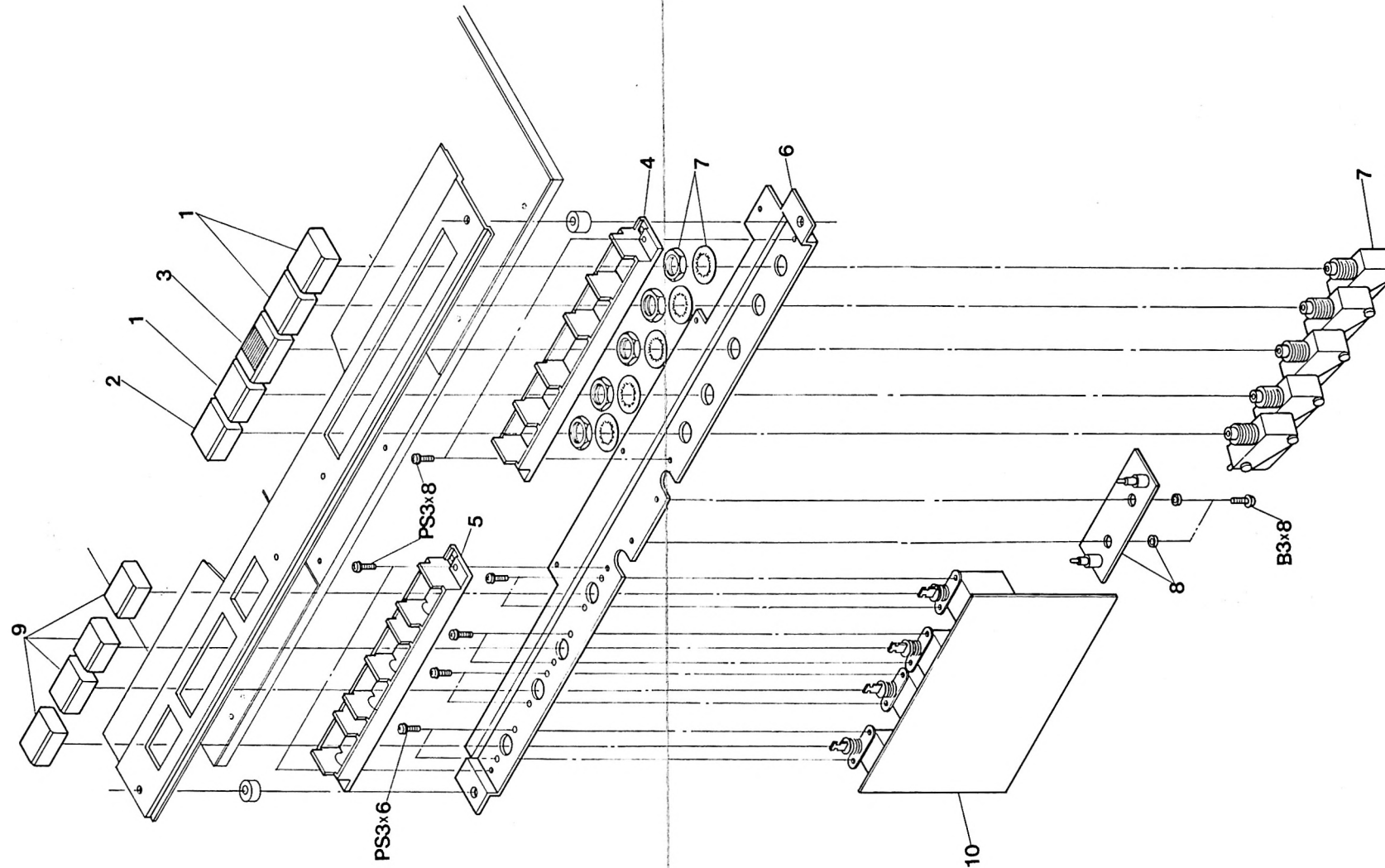

CB-252 CONTROL SWITCH ASSEMBLY [6]:

<u>Ref. No.</u>	<u>Description</u>	<u>Parts No.</u>	<u>Notes</u>
6- 1	Knob	KN2069	
2	Knob	KN2070	
3	Knob	KN2071	
4	Guide, Switch	CB20602	
5	Guide, Switch	CB20701	
6	Bracket, Transport Control	T506705	
7	Switch	WH11007	
8	PCB Ass'y, LED	PB-83E	
9	Knob	KN2072	
10	Assembly, Switch	PB-78HB	
	Switch	WH12008	

KW-4J REEL ASSEMBLY [7]:

<u>Ref. No.</u>	<u>Description</u>	<u>Parts No.</u>	<u>Notes</u>
7- 1	Reel Drive Nail	KW0E038	
2	Reel Table	KW4J002 ... (a)	
3	Drum	KW0B017 ... (b)	
	Reel Drive Nail	KW0E038 ... (c)	
		(b)+(c) Ass'y	KW0B017S
		(a)+(b)+(c) Ass'y	KW4J001
4	Escutcheon, Reel	KW0H007A	
5	Bracket, Reel Motor	KW0G016	
6	Motor, Reel	MR1C012	
7	Capacitor, Reel Motor	CZ10023	
	PCB, Capacitor	PB9A179	
8	Bracket, Capacitor	KW4B003	
9	Bracket, Capacitor	KW4B004	
10	Base, Brake	KW0G013	
11	Base, Brake	KW0G012	
12	Retaining Ring, E-Type	F74TE09	
13	Brake Band Ass'y	KW-4E-A	
	Lever, Brake	KW0D014	
	Pin, Brake Band	F63316	
	Brake Band	KW-4E-A	
14	Spring	GS1024	
15	Guide, Brake Band	KZ3A047	
16	Pin, Solenoid Plunger	KZ5A003	
17	Guide, Brake Band	KW4B001	
18	Brake Drum	KW0A012	
19	Solenoid	GP1F02	
20	Cushion	PZ1B049	
21	Retaining Ring, E-Type	F74TE15	

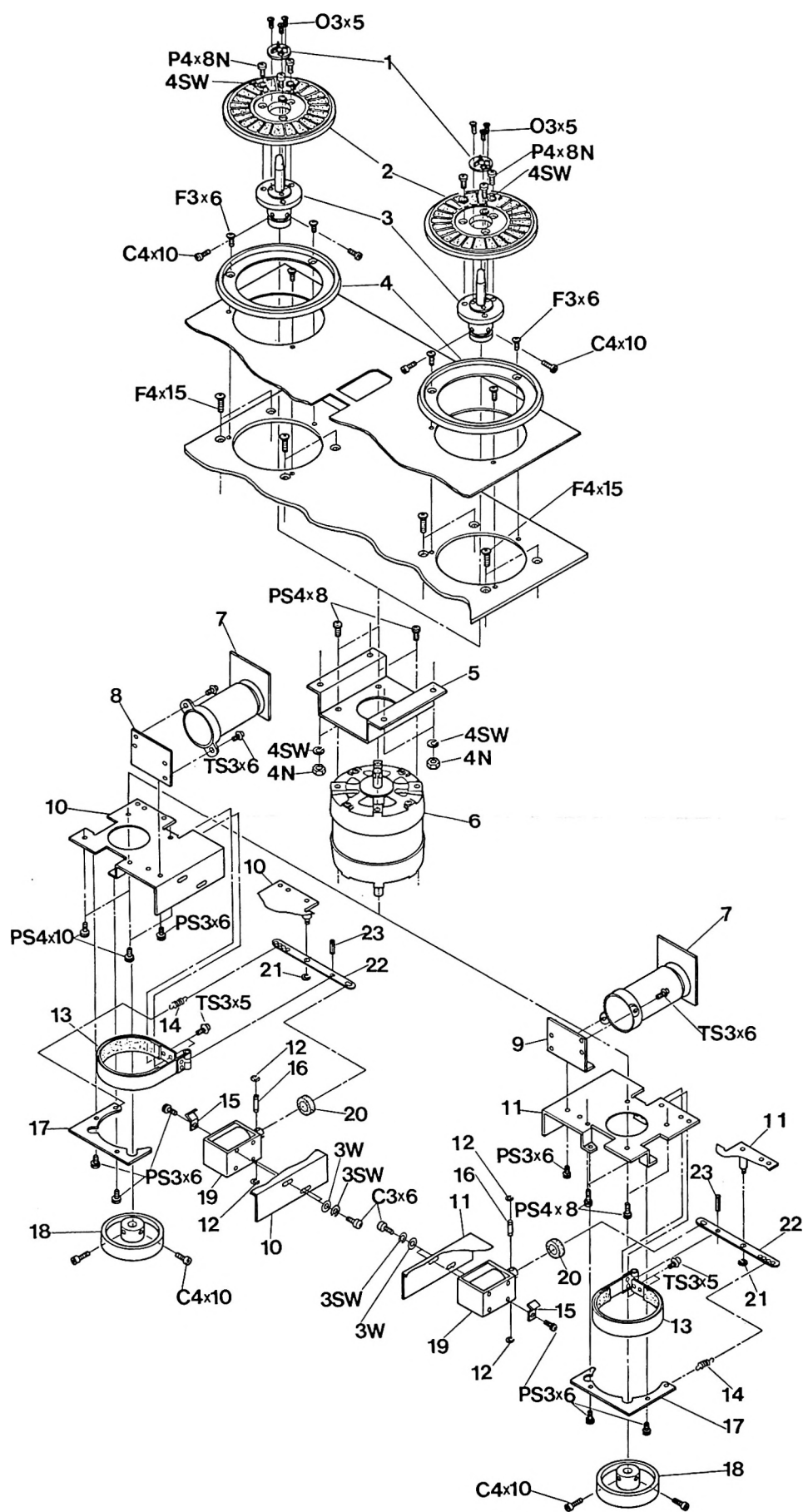

CB-705 CONNECTOR PANEL ASSEMBLY [8]:

<u>Ref. No.</u>	<u>Description</u>	<u>Parts No.</u>	<u>Notes</u>
8- 1	Panel, Connector	CB70501	
2	Connector, XL-Type Receptacle	CN103046	
3	Connector, XL-Type Plug	CN103045	
4	Connector, AC	CN603012	
5	Connector, Remote Control	CN7C-006	
6	Connector, Terminal Ground	CN901040	
7	Panel, Rear	A106204	

CB-705 CONNECTOR PANEL ASSEMBLY [8]:

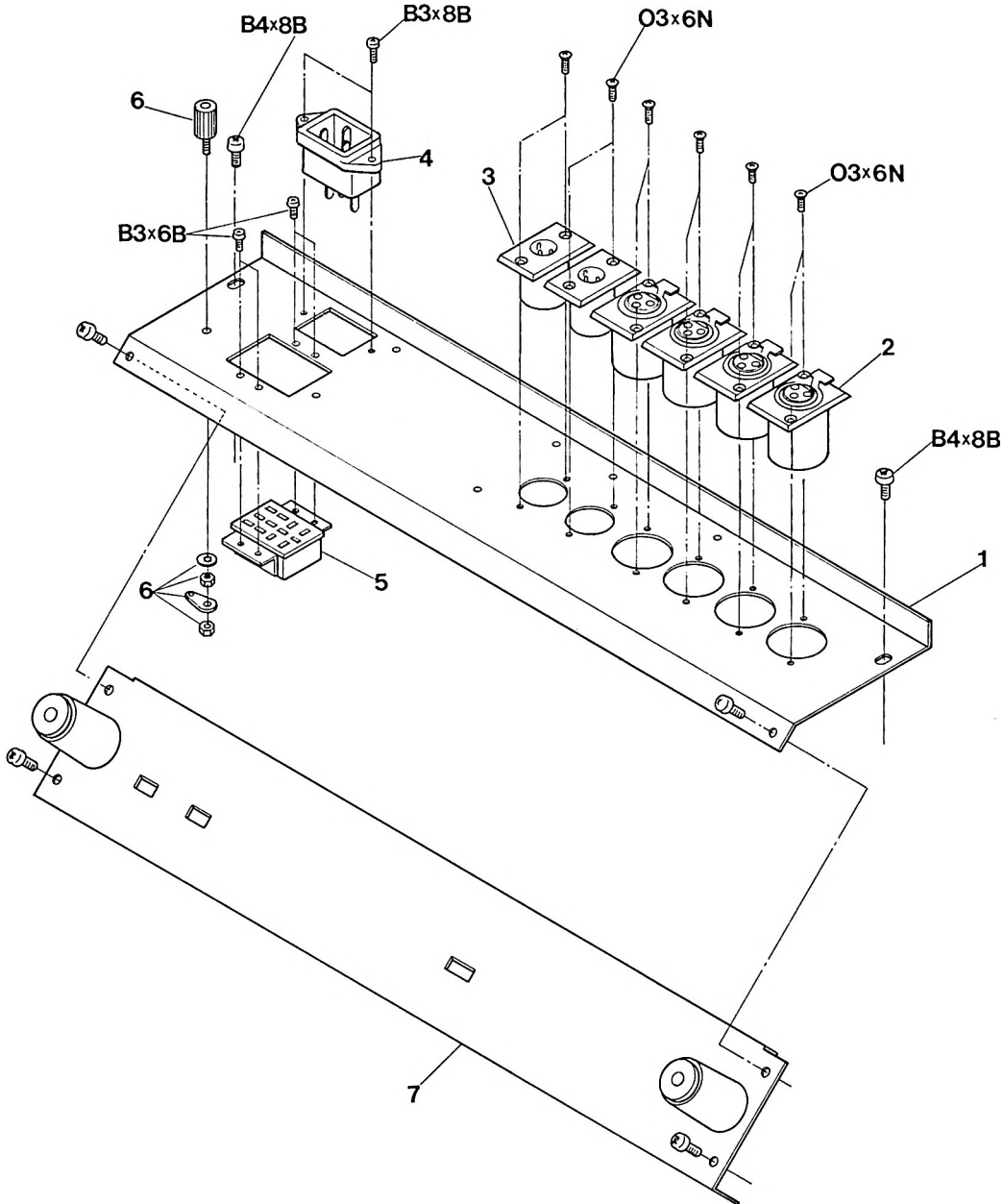

A1062 REC REPRO AMP ASSEMBLY [9]:

<u>Ref. No.</u>	<u>Description</u>	<u>Parts No.</u>	<u>Notes</u>
9- 1	Knob, Cap	KN1058	
2	Knob, Cap	KN1052	
3	Knob	KN1065	
4	Knob	KN1063	
5	Panel, VU Meter	A1062	
6	Base, VU Meter	A106201	
7	Frame, Amp.	A102807	
8	Frame, Amp.	A102808	
9	Bracket, Amp. Rear	A106206	
10	VU Meter	ME11005	
11	Cushion, Felt	PZ1B013	
12	Cushion, Felt	PZ1B012	
13	Cushion, Felt	PZ1B010	
14	Knob, Yellow	KN1060	
15	Knob, Black	KN1061	
16	Knob, Orange	KN1076	
17	Potentiometer	RV224083	
18	Connector, Phone	CN602144	
19	Switch	WH340013	
20	PCB Ass'y, Audio	PB-16EB	
21	PCB Ass'y, VU Amp	PB-16D	
22	Washer, Nylon	KZ6C017	
23	PCB Ass'y, LED	PB-83BB	
24	PCB Ass'y, LED	PB-81J	
25	PCB Ass'y, LED	PB-83AB	
26	PCB Ass'y, LED	PB-83CAA	
27	PCB Ass'y, REC EQ	PB-81Q	
28	Screw	FC3x8B	
29	Screw	FC3x25B	
30	Washer, Decoration	KZ6C051	
31	Washer, Nylon	KZ6C011	
32	Collar	A102809	

A1062 REC & REPRO AMP. ASSEMBLY [9]:

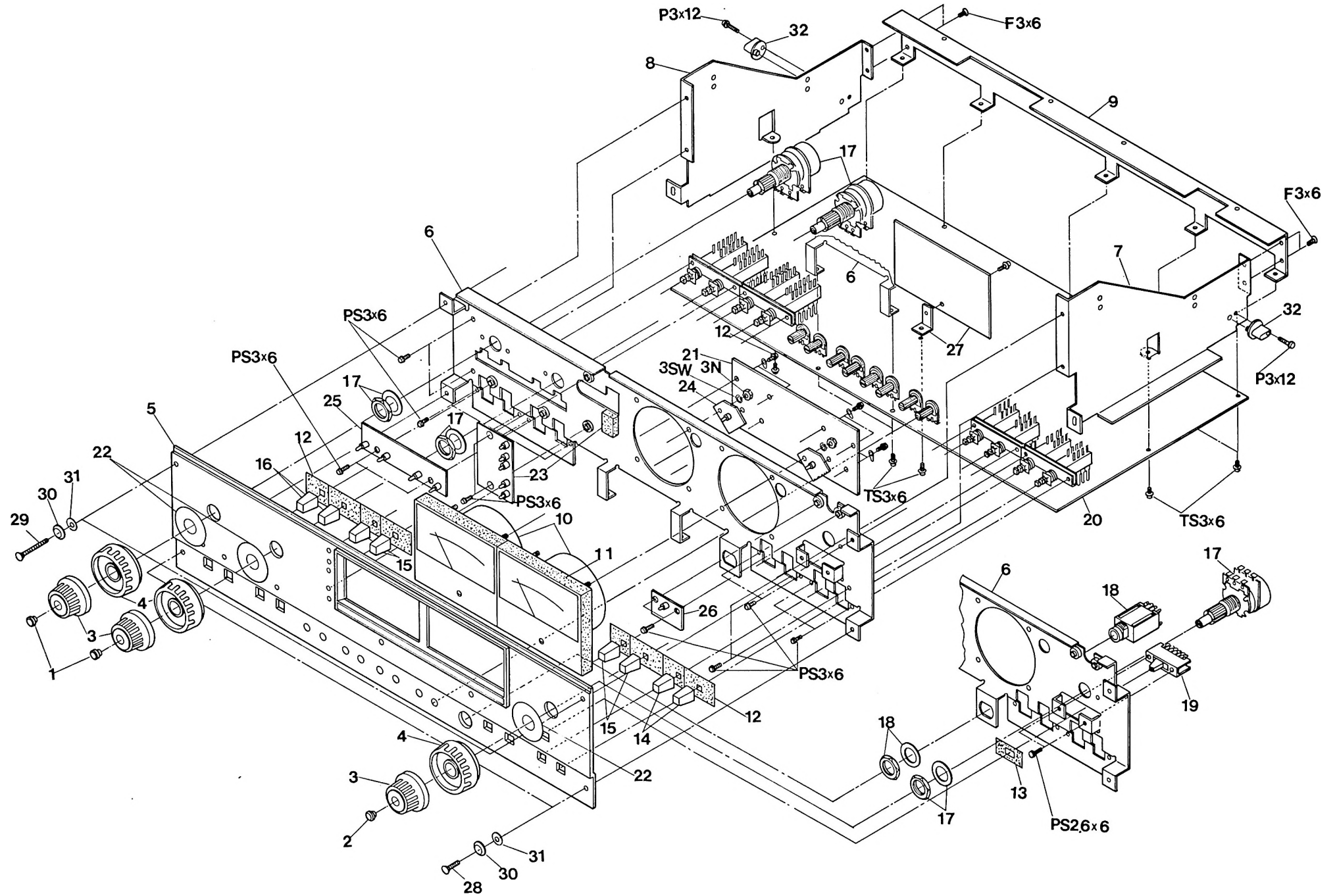

SECTION X
CIRCUIT DIAGRAMS

A10620B REC & REPRO AMP.

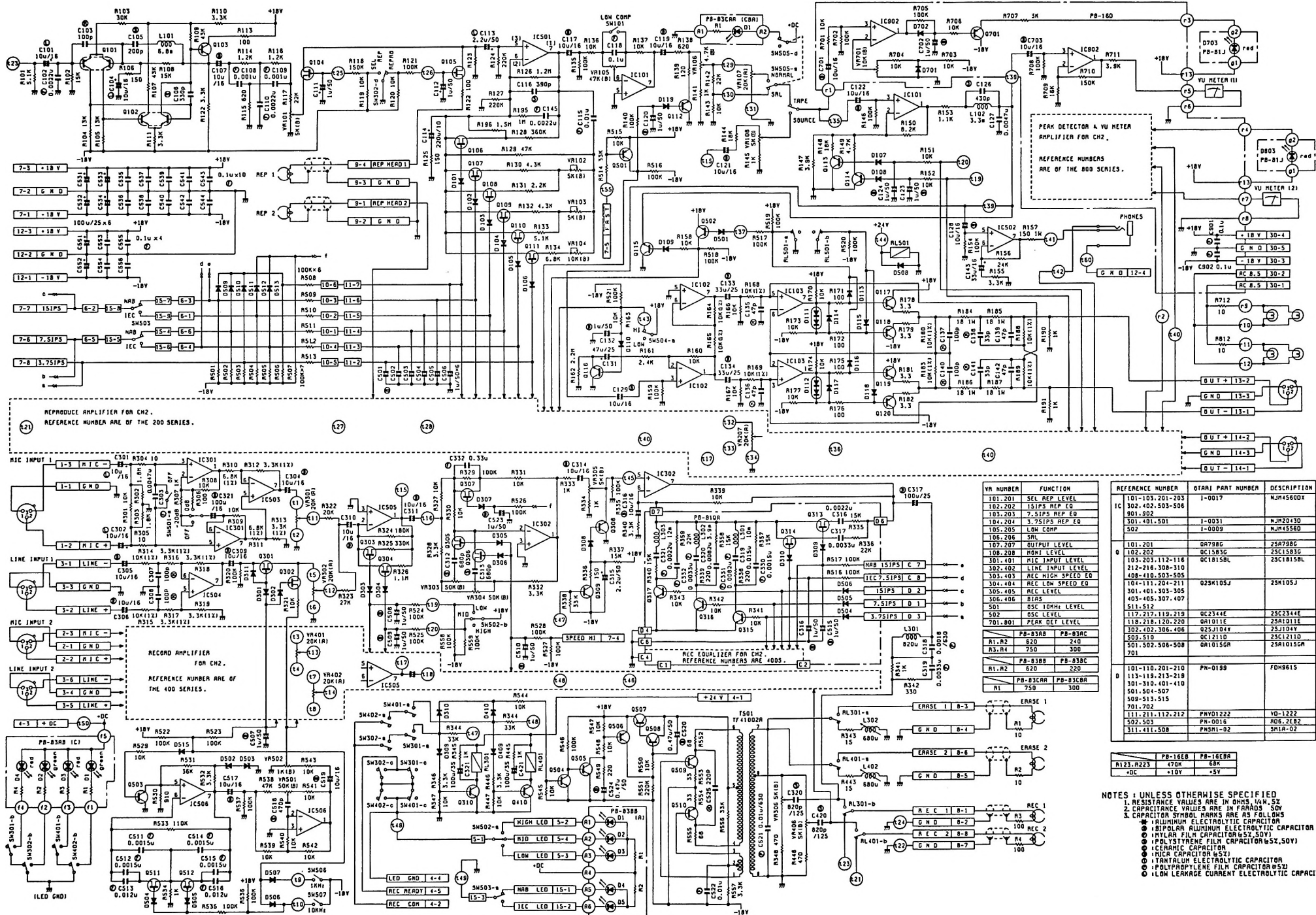

PN NUMBER	FUNCTION
101-201	SEL REP LEVEL
102-202	15IPS REP EQ
103-203	7.5IPS REP EQ
104-204	3.75IPS REP EQ
105-205	LOW COMP
106-206	SRL
107-207	OUTPUT LEVEL
108-208	REMI LEVEL
301-401	MIC INPUT LEVEL
302-402	LINE INPUT LEVEL
303-403	REC HIGH SPEED EQ
304-404	REC LOW SPEED EQ
305-405	REC LEVEL
306-406	BIAS
501	OSC 10KHZ LEVEL
502	OSC LEVEL
701-801	PEAK DET LEVEL
PB-83AB PB-83AC	
AL.R2	620 240
AS.R4	750 300
PB-83BB PB-83BC	
AL.R2	620 230
PB-83CAR PB-83CB	
AL.R2	750 300

REFERENCE NUMBER	QFARI PART NUMBER	DESCRIPTION
101-103, 201-203	I-0017	NJM45600X
302, 402, 503-506		
901, 902		
301-401, 501	I-0031	NJM20430
502	I-0009	NJM45580
101-201	00798G	25M798G
102-202	0C1583C	25C1583C
103-203, 112-116	0C1815BL	25C1815BL
212-216, 300-310		
408-410, 503-505		
104-111, 204-211	025K105J	25K105J
301, 401, 303-305		
403-405, 307, 407		
511, 512		
117-217, 119, 219	0C2344E	25C2344E
118, 218, 120, 220	0A1011E	25A1011E
102, 402, 306, 406	025J104Y	25J104Y
509, 510	0C12110	25C12110
501, 502, 504-507	0A1015GR	25A1015GR
508, 513, 515		
701, 702		
111, 211, 112, 212	PNV01222	VD-1222
502, 503	PN-0016	808-2E82
311, 411, 508	PN81-02	5M1A-02
PB-16EB PB-16EBRA		
R123, R223	470R	68K
+DC	+18V	+5V

NOTES 1 UNLESS OTHERWISE SPECIFIED
 1. RESISTANCE VALUES ARE IN OHMS, 1/4W, 5%
 2. CAPACITANCE VALUES ARE IN FARADS, 50V
 3. CAPACITOR SYMBOL MARKS ARE AS FOLLOWS
 * ALUMINUM ELECTROLYTIC CAPACITOR
 @ BIPOLAR ALUMINUM ELECTROLYTIC CAPACITOR
 @ MYLAR FILM CAPACITOR (5% 50V)
 @ POLYSTYRENE FILM CAPACITOR (5% 50V)
 @ CERAMIC CAPACITOR
 @ MICR. CAPACITOR (5%)
 @ TANTALUM ELECTROLYTIC CAPACITOR
 @ POLYPROPYLENE FILM CAPACITOR (5%)
 @ LOW LEAKAGE CURRENT ELECTROLYTIC CAPACITOR

AL0680C REC & REPRO AMP.

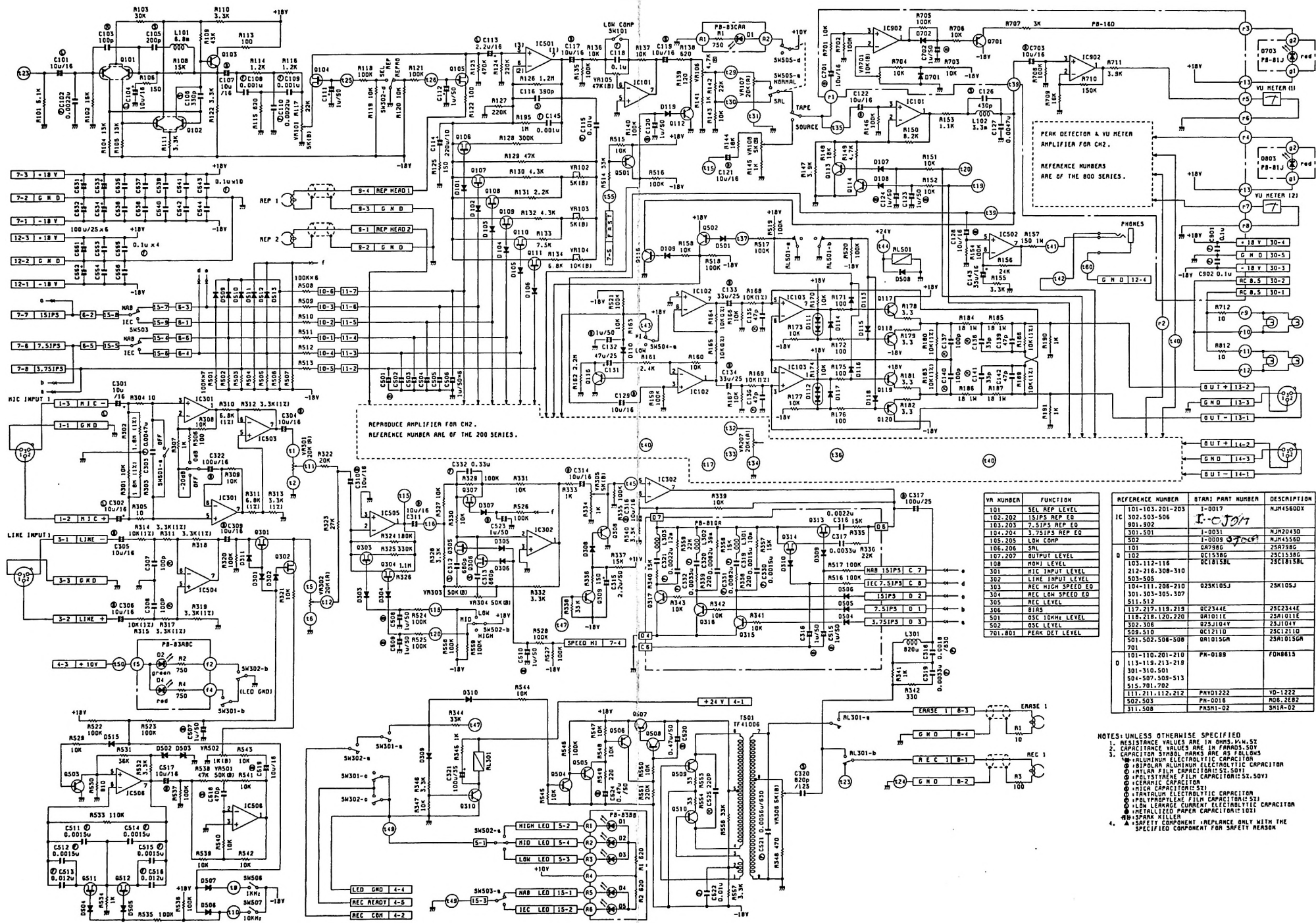

VAR NUMBER	FUNCTION
101	SEL REF LEVEL
102-202	ISIPS REP ED
103-203	7.5IPS REP ED
104-204	3.75IPS REP ED
502	LW COMP
101	SRL
107-207	OUTPUT LEVEL
108	MONI LEVEL
301	MIC INPUT LEVEL
302	LINE INPUT LEVEL
303	REC HIGH SPEED ED
304	REC LOW SPEED ED
305	REC LEVEL
306	BIAS
501	OSC 10KHZ LEVEL
502	OSC LEVEL
701-801	PEAK DET LEVEL

REFERENCE NUMBER	QTY	PART NUMBER	DESCRIPTION
101-103, 201-203	1	0017	NJM45600X
302, 503-506	1	0017	NJM45500X
801, 902	1	0017	NJM45500X
301, 501	1	0031	NJM20430
105, 205	1	0009	NJM45500X
101	1	0017	NJM45600X
102	1	0017	NJM45600X
103, 112-116	1	0017	NJM45600X
212-216, 308-310	1	0017	NJM45600X
303-505	1	0017	NJM45600X
104-111, 206-210	1	023K105J	23K105J
301, 303-305, 307	1	0017	NJM45600X
511-513	1	0017	NJM45600X
117, 217, 118, 218	1	023K44E	23K44E
118, 218, 120, 220	1	023K101E	23K101E
302, 306	1	023J104Y	23J104Y
509, 510	1	023J110	23J110
501, 502, 506-508	1	023K105G	23K105G
701	1	0017	NJM45600X
101-110, 201-210	1	PA-018B	FORN613
113-119, 213-219	1	0017	NJM45600X
301-310, 501	1	0017	NJM45600X
504-507, 509-513	1	0017	NJM45600X
515, 701-702	1	PHY01222	YD-1222
113, 211, 112, 212	1	PA-001B	MOB. 2E82
502, 503	1	PA-018	SMIA-02
311, 508	1	PA-018	SMIA-02

- NOTES: UNLESS OTHERWISE SPECIFIED
1. RESISTANCE VALUES ARE IN OHMS, K, M, S.
 2. CAPACITANCE VALUES ARE IN FARADS, S.
 3. CAPACITOR SYMBOL MARKS ARE AS FOLLOWS:
 * ALUMINUM ELECTROLYTIC CAPACITOR
 * POLYPROPYLENE FILM CAPACITOR
 * POLYESTER FILM CAPACITOR
 * POLYETHYLENE TEREPHTHALATE FILM CAPACITOR
 * POLYBUTYLENE TEREPHTHALATE FILM CAPACITOR
 * POLYVINYLIDENE FLUORIDE FILM CAPACITOR
 * METALLIZED PAPER CAPACITOR
 * CERAMIC CAPACITOR
 * TANTALUM CAPACITOR
 * TANTALUM ELECTROLYTIC CAPACITOR
 * POLYPROPYLENE FILM CAPACITOR
 * POLYESTER FILM CAPACITOR
 * POLYETHYLENE TEREPHTHALATE FILM CAPACITOR
 * POLYBUTYLENE TEREPHTHALATE FILM CAPACITOR
 * METALLIZED PAPER CAPACITOR
 * CERAMIC CAPACITOR
 * TANTALUM CAPACITOR
 * TANTALUM ELECTROLYTIC CAPACITOR
 4. SAFETY COMPONENT (REPLACE ONLY WITH THE SPECIFIED COMPONENT FOR SAFETY REASON)

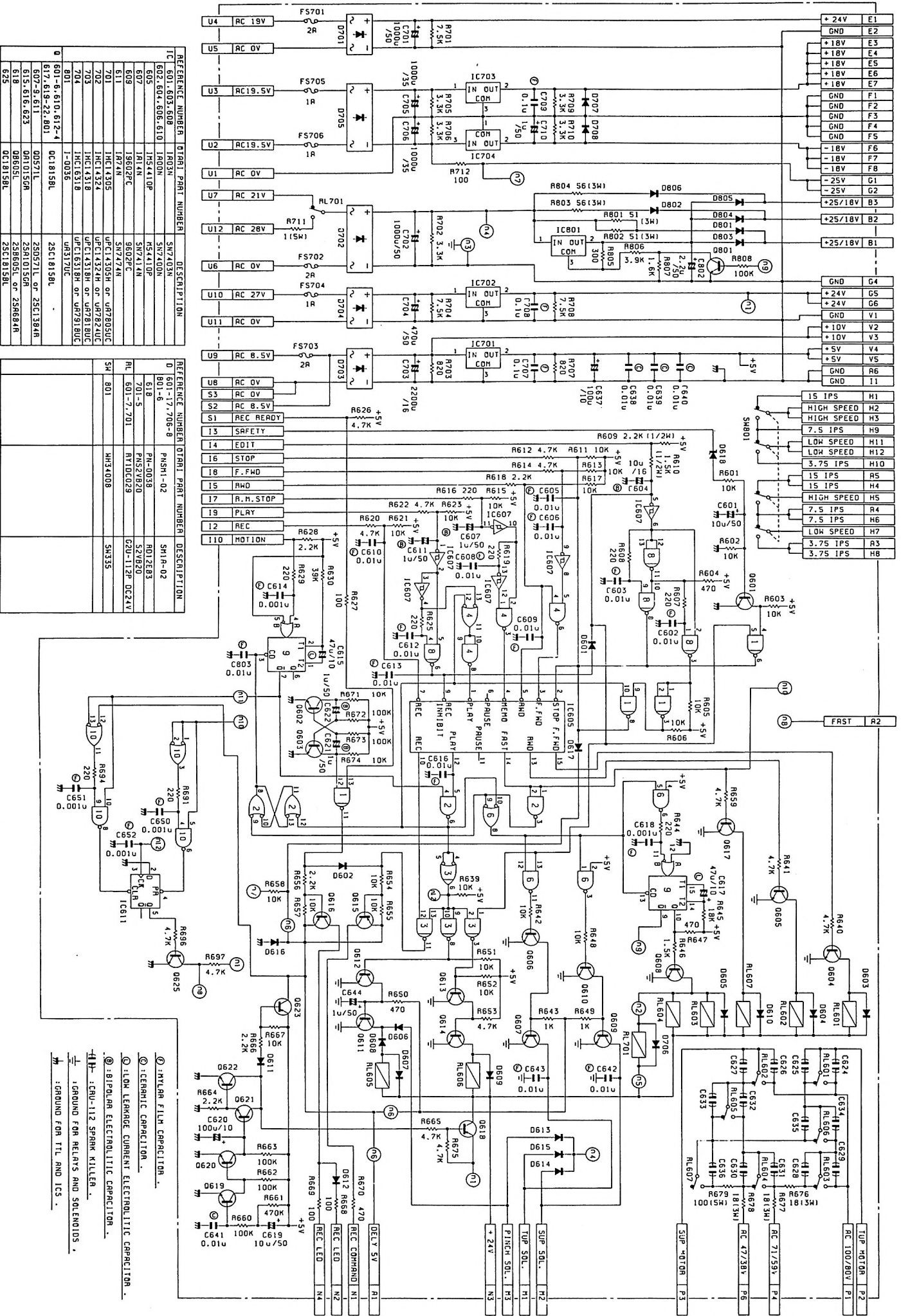

REFERENCE NUMBER	PART NUMBER	DESCRIPTION
IC 601-603, 608	1K03M	5V7403N
602, 604, 606, 610	1K00N	5V7400N
605	1K5410P	5V7410P
607	1K14N	5V7414N
609	1S602PC	9602PC
611	1K74N	5V7474N
701	1K1430S or 1K78050C	5V7430S or 1K78050C
702	1K14324 or 1K78240C	5V74324 or 1K78240C
703	1K14318 or 1K78180C	5V74318 or 1K78180C
704	1K16318 or 1K79180C	5V76318 or 1K79180C
801	1-0036	1-0036
801	28C1815BL	28C1815BL
801-6, 810, 812-4	28S0571L or 28C1384R	28S0571L or 28C1384R
817, 819-22, 801	08571L	08571L
807-9, 811	0810150R	0810150R
815, 816, 823	08605L or 28R684R	08605L or 28R684R
818	08605L	08605L
819	28C1815BL	28C1815BL
825	28C1815BL	28C1815BL

REFERENCE NUMBER	PART NUMBER	DESCRIPTION
D 601-17, 706-8	PH5H-02	5H1A-02
801-6	PH-0038	8012E83
618	PHS2V820	S2V820
701-5	RT1DC029	GD2-112P DC24V
RL 601-7, 701	SM335	SM335
801	HM34008	HM34008

- ⊙: MYLAR FILM CAPACITOR.
- ⊙: CERAMIC CAPACITOR.
- ⊙: LOW LEAKAGE CURRENT ELECTROLYTIC CAPACITOR.
- ⊙: BIPOLAR ELECTROLYTIC CAPACITOR.
- ⊙: 112 SPRINK KILLER.
- ⊙: GROUND FOR TTL AND ICS.

PB-46R TIMER DRIVE P.C.B. ASSEMBLY

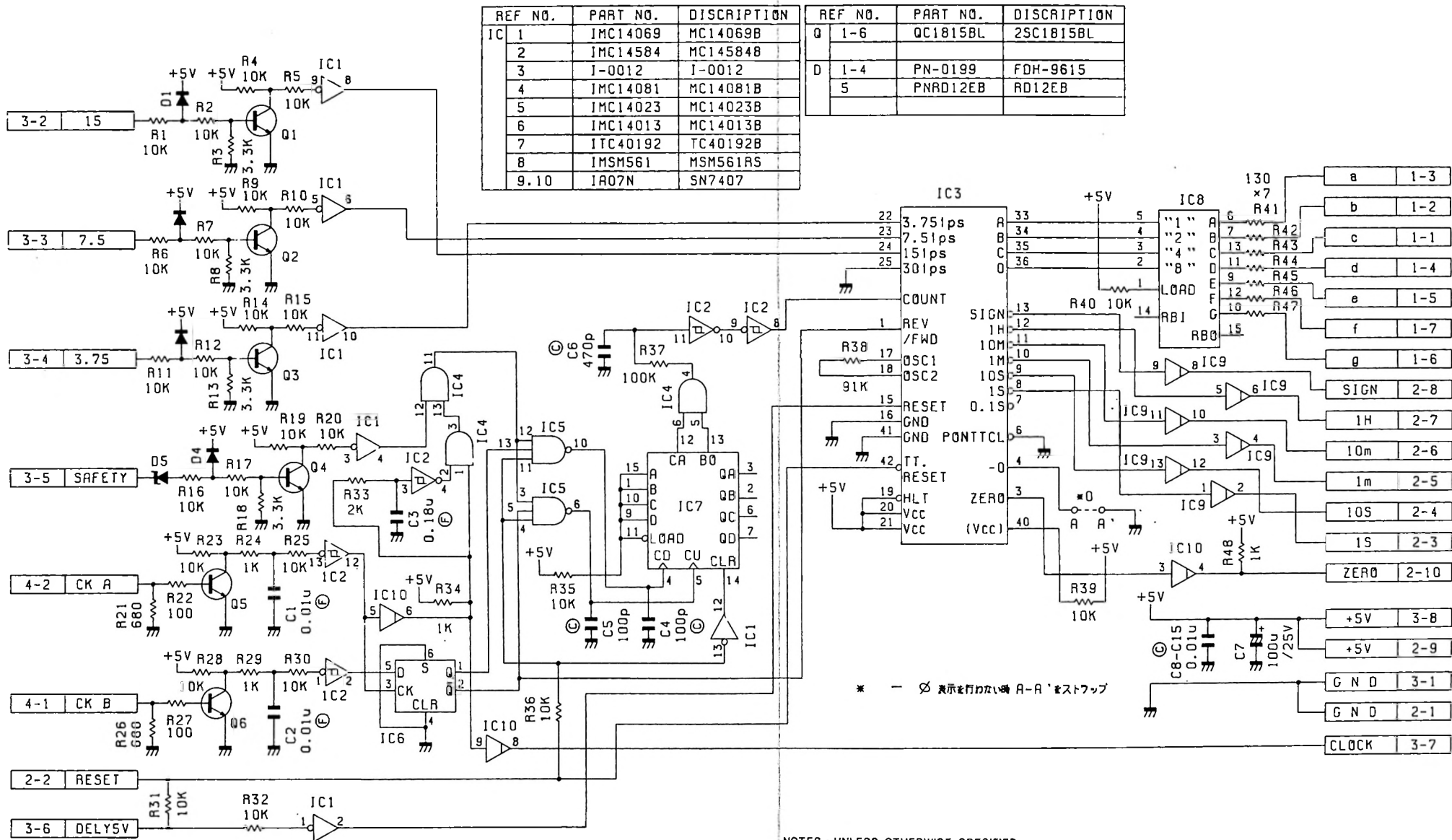

REF NO.	PART NO.	DISCRIPTION	REF NO.	PART NO.	DISCRIPTION
IC 1	IMC14069	MC14069B	Q 1-6	QC1815BL	2SC1815BL
2	IMC14584	MC14584B			
3	I-0012	I-0012	D 1-4	PN-0199	FDH-9615
4	IMC14081	MC14081B	5	PNRD12EB	RD12EB
5	IMC14023	MC14023B			
6	IMC14013	MC14013B			
7	ITC40192	TC40192B			
8	IMSM561	MSM561RS			
9,10	1A07N	SN7407			

NOTES : UNLESS OTHERWISE SPECIFIED

- RESISTANCE VALUES ARE IN OHMS, ±W, 5%.
- CAPACITANCE VALUES ARE IN FARADS, 50V.
- CAPACITOR SYMBOL MARKS ARE AS FOLLOWS.
 -B- : ALUMINUM ELECTROLYTIC CAPACITOR.
 ⊖ : BIPOLAR ALUMINUM ELECTROLYTIC CAPACITOR.
 ⊕ : MYLAR FILM CAPACITOR (±5%, 50V)
 ⊙ : POLYSTYRENE FILM CAPACITOR (±5%, 50V)
 ⊗ : CERAMIC CAPACITOR.
 ⊘ : MICA CAPACITOR (±5%)

- ⊕ : TANTALUM ELECTROLYTIC CAPACITOR.
 ⊖ : POLYPROPYLENE FILM CAPACITOR (±5%)
 ⊙ : LOW LEAKAGE CURRENT ELECTROLYTIC CAPACITOR.
 ⊗ : METALLIZED PAPER CAPACITOR (±10%)
 ⊕ : SPARK KILLER.
 ⚠ : SAFETY COMPONENT ; REPLACE ONLY WITH THE SPECIFIED COMPONENT FOR SAFETY REASON.

* - ⊕ 表示を行わない時 A-A' をストップ

WIRING DIAGRAM TRANSPORT

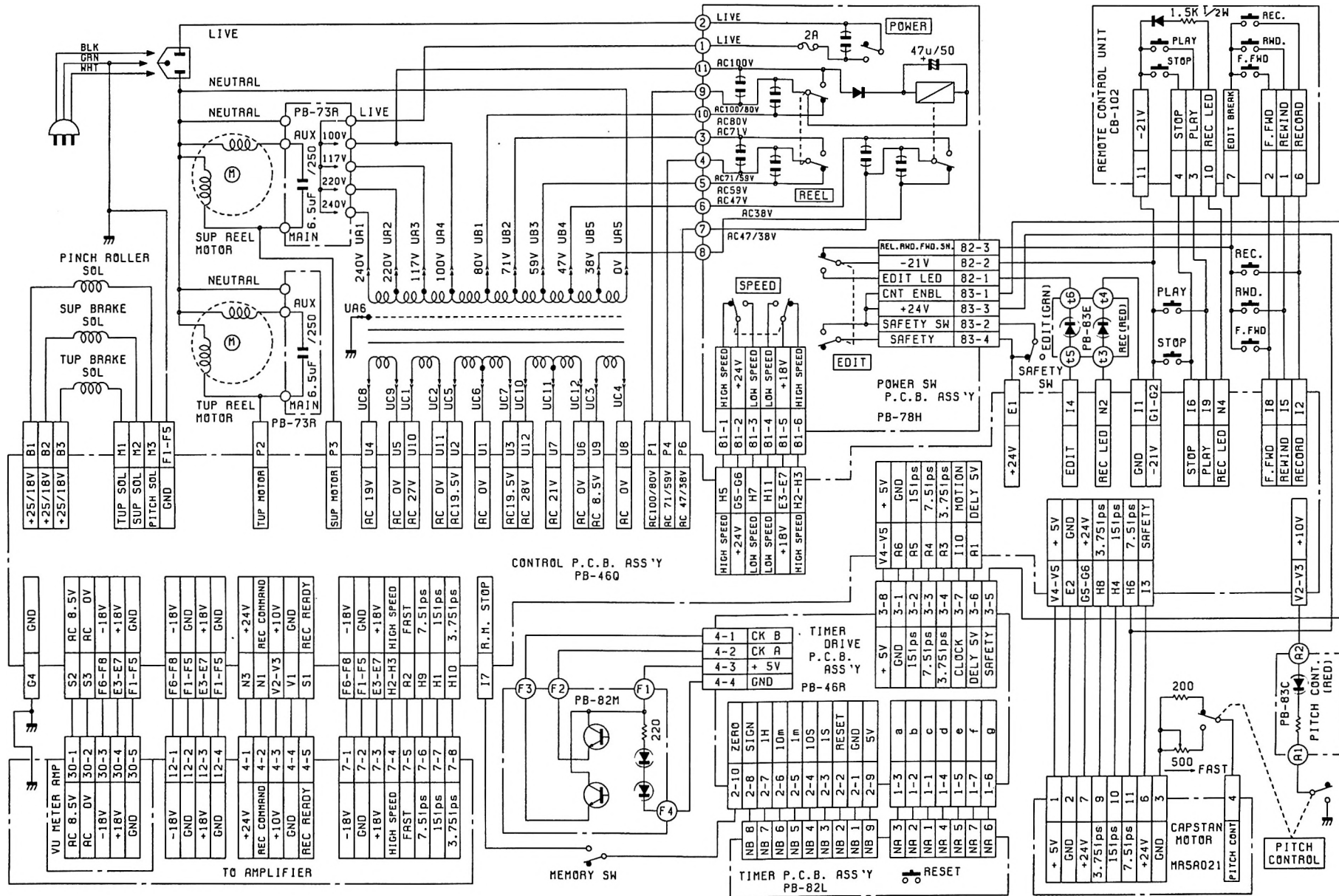

NOTES: UNLESS OTHERWISE SPECIFIED
 1. RESISTANCE VALUES ARE IN OHMS, %4, %5
 2. CAPACITANCE VALUES ARE IN FARADS, 50V
 3. CAPACITOR SYMBOL MARKS ARE AS FOLLOWS
 (A) ALUMINUM ELECTROLYTIC CAPACITOR
 (B) BIPOLAR ALUMINUM ELECTROLYTIC CAPACITOR
 (C) MYLAR FILM CAPACITOR (±5%, 50V)
 (D) POLYSTYRENE FILM CAPACITOR (±5%, 50V)
 (E) CERAMIC CAPACITOR
 (F) MICA CAPACITOR (±5%)

4. (G) TANTALUM ELECTROLYTIC CAPACITOR
 (H) POLYPROPYLENE FILM CAPACITOR (±5%)
 (I) LOW LEAKAGE CURRENT ELECTROLYTIC CAPACITOR
 (J) METALLIZED PAPER CAPACITOR (±10%)
 (K) SPARK KILLER
 (L) SAFETY COMPONENT: REPLACE ONLY WITH THE SPECIFIED COMPONENT FOR SAFETY REASON