

Frequency counters
PM 6667 and PM 6668

Instruction manual

9499 463 10399
801115

S&i
Scientific & Industrial equipment division



PHILIPS

Frequency counters

PM 6667 and PM 6668

Instruction manual

9499 463 10399
801115

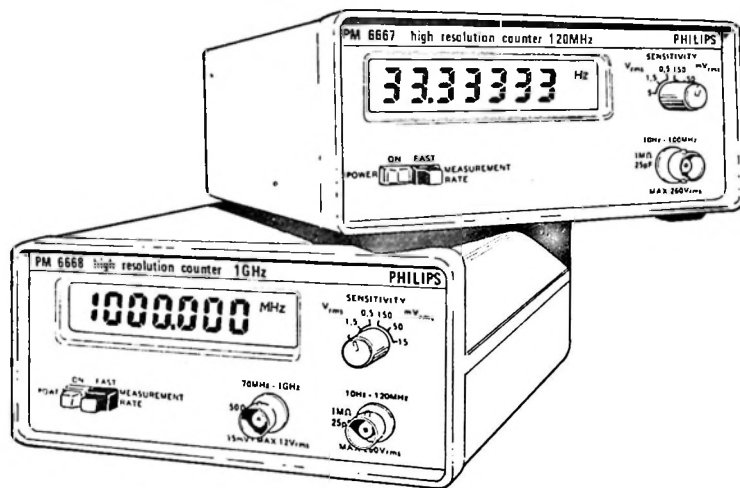

Operating manual	2
Gebrauchsanleitung	8
Notice d'emploi	14
Bruksanvisning	20
Istruzioni per l'uso	26
Gebruiksaanwijzing	32
Service manual	40



PHILIPS

1. Introduction

The PM 6667 and PM 6668 are microcomputer based frequency counters, spanning a frequency range of 10 Hz ... 120 MHz (PM 6667) and 10 Hz ... 1 GHz (PM 6668).

The use of the microcomputer allows a new approach in frequency measurements, that eliminates the traditional ± 1 cycle error. By making a multiple period measurement and computing the reciprocal value, these counters perform high resolution frequency measurements on low frequency signals.

Another microcomputer feature in these counters is the automatic range selection. The measuring result is always displayed with maximum resolution without overflow and with proper indication of Hz, kHz, MHz and decimal point.

There is choice between two measurement rates; NORMAL

with 7-digits resolution every second or FAST with 6 or 7-digits resolution every 200 ms. The fast mode is used for measuring changing frequencies as with tuning.

The following options are available: a more stable time base version with TCXO (/02 version), a rechargeable battery unit PM 9601 that can be mounted inside the counter, an impact resistant (ABS) protective carrying case PM 9602 and a 19" rack/panel mount adapter PM 9603.

The 7-digit liquid crystal (LCD) display contains also the unit and decimal-point indicators.

After you switch on the counter, a self test is executed. Should an error be detected, it is shown on the display by a diagnostic code.

WARNING

Before connecting the instrument to the line voltage, read the safety regulations on page 5.

2. Technical specification

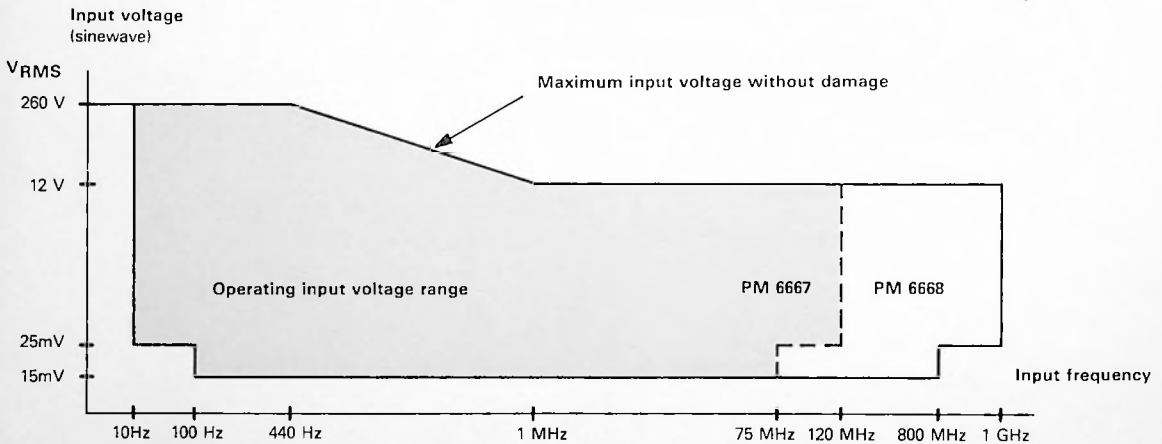

Frequency range

PM 6667: 10Hz ... 120MHz

PM 6668: 10Hz ... 1GHz

RF-input: (PM 6668 only)

15mVRMS sinewave;
70MHz ... 800MHz

25mVRMS sinewave;
800MHz ... 1GHz

triggering on any waveform and duty cycle.

Coupling: AC

Input impedance

LF-input: $1M\Omega // \approx 25pF$

RF-input: 50Ω nominal with VSWR < 2 (PM 6668 only)

Input sensitivity

(in 15mVRMS position)

LF-input: 15mVRMS sinewave;
100Hz ... 75MHz

25mVRMS sinewave;
10Hz ... 120MHz

45mV_{p-p} for pulses with a pulse duration of $\geq 7ns$

(see input voltage characteristics)

Input attenuation

LF-input: x 1 to x 300 in 6 positions

RF-input: automatic attenuation

Trigger level

A fixed (+, 0 or -) voltage is automatically applied to ensure proper

Max. input voltage without damage

DC: 300V

AC: 260VRMS at $\leq 440Hz$, falling to 12VRMS at 1 MHz (see input voltage characteristics above)

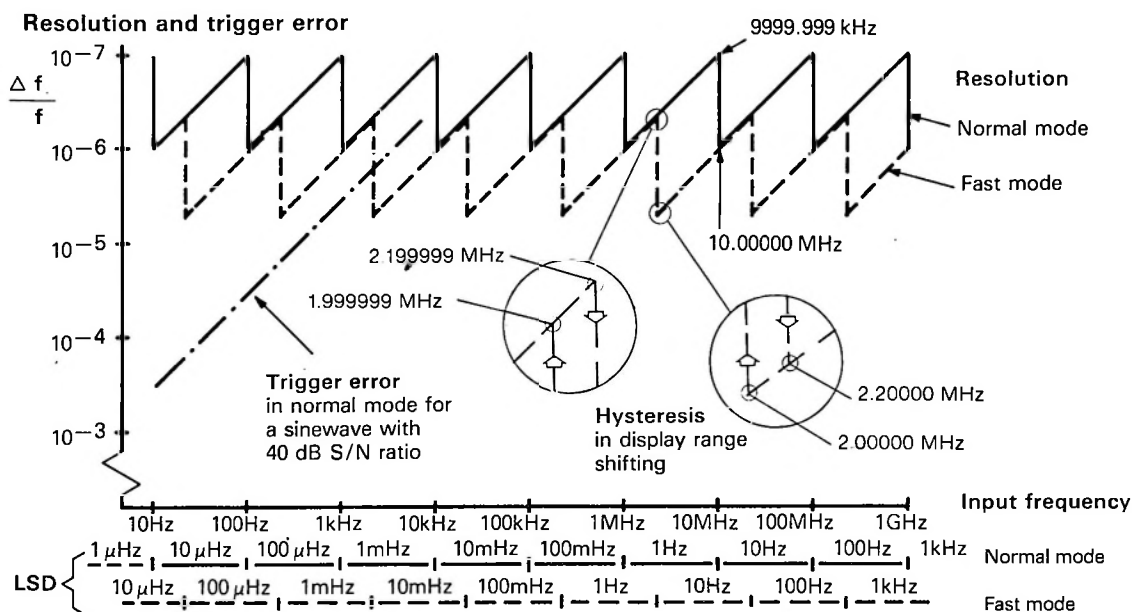

Measurement rate

Normal, (out): approx 1 measurement/s
Fast, (in): approx 5 measurements/s;
 at frequencies below 100Hz, the measurement rate gradually slows down to one measurement per second to reduce the trigger error influence.

Display

7 digits, 11.5 mm, liquid crystal display with unit indication of Hz, kHz, MHz and LO BAT.

Inaccuracy (relative frequency error)

$\pm \frac{\text{LSD}}{\text{input frequency}} \pm \text{rel. trigger error}$
 $\pm \text{time base error}$

Rel. trigger error:

For any waveshape:

Measurement rate
 $\text{Signal slope (V/s)} \times \text{peak-to-peak noise voltage}$

Time base characteristics

Time base version	/01 (standard)	/02 (TCXO)
X-tal frequency	10MHz	10MHz
Ageing	$\leq 5 \times 10^{-7}/\text{month}$	$\leq 1 \times 10^{-7}/\text{month}$
Temperature stability		
0 ... 50°C, ref. to +25°C	$\leq 1 \times 10^{-5}$	$\leq 1 \times 10^{-6}$
20 ... 30°C, ref. to +25°C	$\leq 3 \times 10^{-6}$ (typical)	$\leq 3 \times 10^{-7}$ (typical)

For sinewaves:

Measurement rate
 $\frac{\text{Measurement rate}}{\text{Input frequency} \times \pi \times \text{S/N ratio}}$

Example: for S/N ratio of 100 (40dB) and sample rate of 1 measurement/s, the trigger error is

3×10^{-3}
 $\frac{\text{input frequency}}$

Resolution

For the least significant digit (LSD) and relative resolution see graph above

Ext. reference input

Frequency: 10MHz
 Input voltage range: 0.5V_{RMS}...12V_{RMS}
 Input impedance: approx. 2kΩ

Power requirements

115/230V, ±15%, 50 ... 60Hz; 15VA
 or by built-in optional battery pack PM 9601 or by external 12V battery.

Safety

According to IEC 348 and CSA 556 B.

Line interference

Below class II CENELEC/CISPR

Dimensions and weight

Width: 160 mm (6,3 in)
 Height: 77 mm (3 in)
 Depth: 180 mm (7,1 in)
 Weight: 1,2 kg (2,6 lb)

Environmental conditions

Temperature:

Storage: -40°C ... +70°C
 Operating: 0°C ... +45°C

Altitude/barometer pressure:

Storage: 15000 m (50000ft)
 /15.2kN/m²
 Operating: 5000 m (15000 ft)
 /53.3kN/m²

Humidity:

10% ... 90% RH, (26°C dew point)

Vibration test: according IEC 68 Fc
Bump test: according IEC 68 Eb
Handling test: according IEC 68 Ec
Transport test: according NLN - L88

3. Accessories

3.1. Standard accessories

(Supplied with the instrument)

- Line power cord.
- Instruction manual.

3.2. Optional accessories

(To be ordered separately)

- PM 9601 Battery unit.
- PM 9602 Carrying case.
- PM 9603 19" rack/panel mount adapter.
- PM 9665 B 50kHz low pass filter, BNC—BNC.
- PM 9236 15 MHz, 10 M ohm attenuator probe set.
- PM 8935 250MHz, 10 M ohm attenuator probe set.
- Battery jack (see section 5 and 7.5 in this manual).

4. Battery unit PM 9601

4.1. General information

The PM 9601 is a rechargeable battery unit for inside mounting in the counters PM 6667 and PM 6668.

The unit contains a standard 6V, sealed battery of solid gel lead acid type. It further contains the charging and over-charge protection circuitry.

The battery unit is fixed with four screws in the metal inner-frame of the cabinet (see the installation instructions).

The battery is of a standard type and is available from variety of battery manufacturers. To obtain spare batteries, contact directly your battery supplier who stores fresh and fully charged batteries:

Manufacturer	Country of origin	Type	Capacity
Sonnenschein*	W-Germany	3GX3S	3 Ah
Varta*	W-Germany	Accu Pb30704063	3 Ah
Gold Gelyte	USA	Pb 626-1	2.6 Ah
Elpower	USA	Ep 626A-6	2.6 Ah
SAFT*	France	PA 601	4 Ah
Kono	Japan	6-26k	2.6 Ah

* recommended brand

WARNING

The capacity of rechargeable batteries degrades when the batteries are not used or recharged frequently. Read therefore carefully the instructions for storage!

4.2. Recharging

The battery is automatically recharged when the counter is connected to the line voltage and the power switch is in OFF position.

When "LO BAT" is indicated on the display, about 15 minutes of operation remain before recharging is needed.

The counter automatically switches over to internal battery supply if line voltage fails.

To prevent unwanted discharging of the batteries when the counter is not used, always use the power switch to turn off the counter, not the line power cord.

Recharging time (typical at 20°C) 10h to 90% of full capacity, 5h to 70% of full capacity.

4.3. Storing

Avoid storage of completely discharged batteries.

When the instrument is not in use, set power switch in OFF position but keep the instrument connected to the line voltage. The battery will then be kept fully charged and always ready for use. If the instrument can not be connected to the line voltage or when the battery pack is stored outside the instrument, recharging during 5 to 10h every 3 months is recommended.

If longer storage periods are needed, remove the fuse in the battery unit and store the battery cool and dry.

WARNING

Permanent use and storage at high temperatures adversely affects the life of the battery.

Prolonged storage and operation above +40°C and charging above +35°C should be avoided.

For storage at -40°C, the battery must be charged to at least 75% of its full capacity.

Other environmental conditions are the same as for the main instrument.

Additional weight for battery pack: 0.75 kg.

Fuse: 1.6A fast action.

5. External battery

An external 12V battery can be used to power the counter. Replace rear BNC connector by a battery jack as described in section 7.5. of this manual.

NOTE

The battery jack including the plug can be obtained free of charge from:

Philips Elektronikindustrier AB
Div. I
Supply Center
S-175 88 JÄRFÄLLA
Sweden

Please indicate the type number and the serial number of your instrument.

6. Safety regulations

(in accordance with IEC 348)

Before connecting the instrument to the line voltage, visually check the cabinet, controls and connectors etc. to ascertain that no damage has occurred in transit.

If any defects are apparent, do not connect instrument to the mains (line). The instrument must be disconnected from all voltage sources, and any high voltage points discharged before any maintenance or repair work is carried out.

If adjustments or maintenance of the operating instrument with covers removed is inevitable, it must be carried out only by a skilled person who is aware of the hazard involved.

NOTE

All parts on the primary side of the transformer are CSA approved and should be replaced only by original parts.

7. Installation

7.1. Line connection

Before connecting the instrument to the line, make sure it is set to the local line voltage. On delivery, the instrument is set to 115V or 230V $\pm 15\%$, which is indicated on the rear of the instrument. If the instrument has to be set to another voltage than indicated, contact your local service organization.

The service manual contains setting instructions.

7.2. Grounding

The instrument is grounded via the three-core line power cord plugged into an outlet with protective ground contact.

No other way of safety grounding is allowed.

7.3. Internal and external standard

The counter can be set to external or internal standard by setting the jumper connector DV 101 as shown in the figure below.

At delivery the counter is set to internal standard.

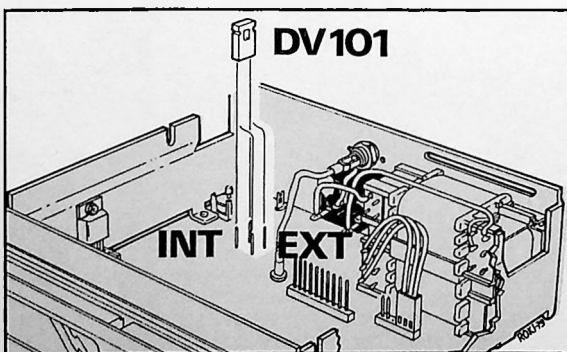

7.4. Internal battery unit PM 9601

- Remove housing of counter.
- Remove the upper screening plate.
- Remove +5V regulator IC 112 (see figure below).
- Place battery unit as shown in figure below. Keep wires from battery to p.c. board along the edges of the battery.
- Mount the new screening plate as shown in figure below and secure it to the sidewalls of the counter with 2 screws.
- Secure unit with screws to sidewalls of counter.

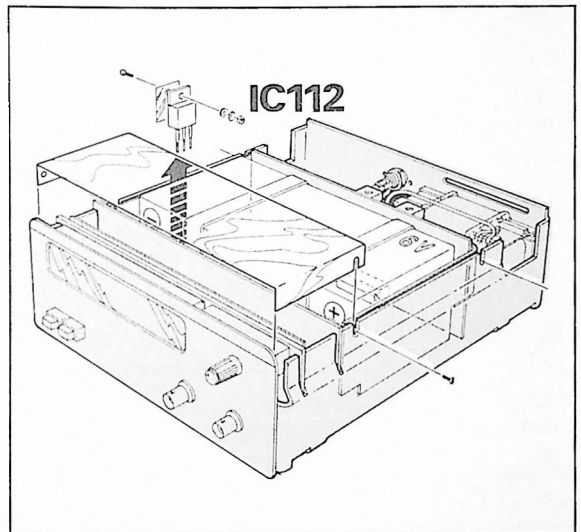

7.5. External Battery Jack

The rear BNC connector for External Standard can be replaced by a battery jack for External Battery supply. The jack fits to DIN 45323.

Proceed as follows to change from BNC connector to battery jack:

- Loosen coaxial cable from p.c. board and unsolder central lead from BNC connector.
- Replace BNC connector with battery jack and connect the two-pole connector so it fits the polarity of your battery plug. See figure below.

The two pins connector (p/o BU 107) is diode-protected to prevent damage if the input polarity is shifted.

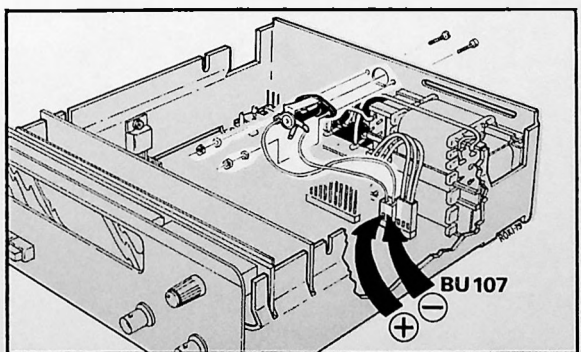

8. Controls & connectors

POWER ON

Turns counter on/off. CAUTION: This is a secondary power switch. Even in the POWER OFF position, the counter contains live conductors and parts. The line cord has to be removed to fully unpower the counter.

In case of line power failure the counter automatically switches over to battery supply.

MEASUREMENT RATE

Sets measurement rate to one of two speeds. NORMAL (released) or FAST (depressed).

NORMAL rate means about 1 measurement/s and FAST rate about 5 measurements/s. The measurement rate in the FAST position will be reduced at lower frequencies down to about 1 measurement/s at 10Hz.

SENSITIVITY

Sets input sensitivity in 6 steps from 15mV_{RMS} to 5 V_{RMS}.

NOTE: to reduce the influence from noise and interference, never set to higher sensitivity than necessary.

LF input

A high-ohmic (1Mohm), AC-coupled input for signals with frequencies from 10Hz to 120MHz. An auto-trigger circuit ensures correct triggering on both sinewaves and pulses with any duty factor.

RF input (PM 6668 only)

A low-ohmic (50 ohm), AC-coupled input for sinewave signals with frequencies from 70MHz to 1GHz.

The microcomputer of the counter detects the presence of an RF signal and selects this input automatically when the input frequency is high enough for counting. This makes it possible to connect the same signal to both inputs via a T-piece. See figure below.

The counter will then switch automatically between the two inputs when the signal frequency is changing, e.g. when measuring a frequency sweep.

More information on the input signal is given in the Technical Specifications.

EXTERNAL STANDARD or BATTERY

BNC input for external time base standard or, as optional extra, battery jack for external battery.

Line voltage receptacle

Input for line voltage. Always use the three-core line power cord supplied with the counter.

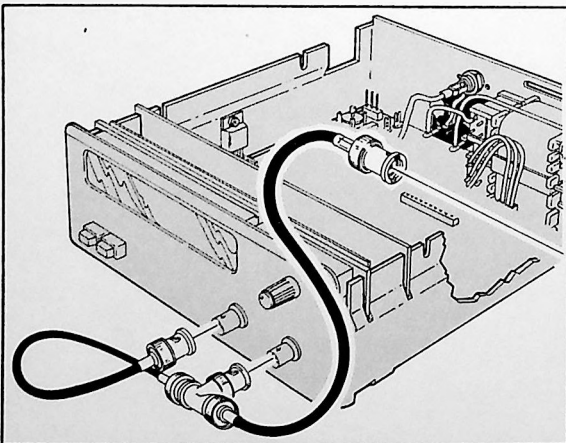
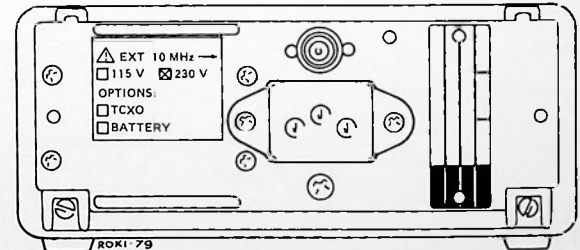
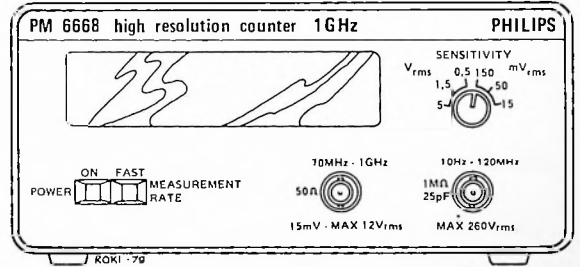
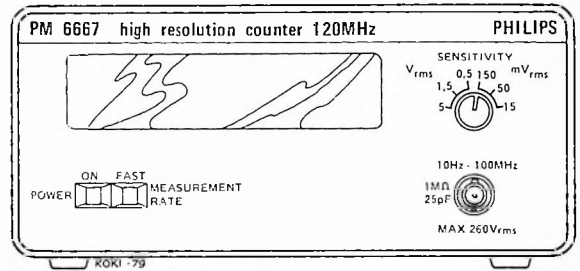



PHILIPS

Gebrauchsanleitung

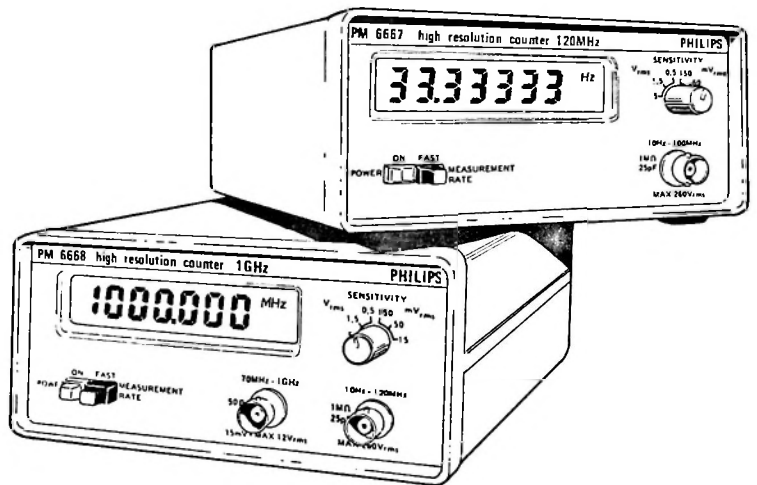

1. Einleitung

PM 6667 und PM 6668 sind mikrocomputergesteuerte Frequenzzähler für den Messbereich von 10 Hz ... 120 MHz (PM 6667) und 10 Hz ... 1 GHz (PM 6668).

Dank des Mikrocomputers eröffnen sich neue Möglichkeiten der Frequenzmessung. Der bisher übliche ± 1 Digit Fehler wird eliminiert. Durch Vielfachperiodenmessung und Berechnung des reziproken Werts ermöglichen diese Zähler die Messung von niedrigfrequenten Signalen mit hoher Auflösung.

Ein weiterer Vorteil des Mikrocomputers ist die automatische Bereichswahl. Die Messergebnisse werden immer mit maximaler Auflösung ohne Überlauf und mit korrekter Angabe der Dimension (Hz, kHz, MHz) und des Dezimalpunkts angezeigt.

Es kann zwischen zwei Messgeschwindigkeiten gewählt werden: NORMAL mit 7-stelliger Auflösung jede Sekunde oder FAST mit 6- oder 7-stelliger Auflösung alle 200 ms. Die

schnelle Betriebsart FAST wird zur Messung wechselnder Frequenzen etwa beim Abgleichen verwendet.

Folgendes Zubehör ist zusätzlich lieferbar: Eine stabilere Zeitbasis mit TCXO* (Bauart/02), eine Batterie-Ladeeinheit PM 9601 zum Einbau im Zähler, eine schlagfeste Tragtasche PM 9602 und ein 19"-Einbau-Adapter PM 9603.

Die 7-stellige LCD-Anzeige gibt Dimension und Dezimalpunkt, sowie den Ladezustand der eingebauten Batterien an.

Nach dem Einschalten nimmt der Zähler eine Eigenkontrolle vor. Werden dabei Fehler festgestellt, leuchtet auf dem Anzeigefeld ein diagnostischer Code auf.

WARNUNG

Lesen Sie die Sicherheitsvorschriften auf Seite 11, bevor Sie das Gerät ans Netz anschliessen!

* TCXO = Temperaturkompensierter Kristalloszillator

2. Technische Daten

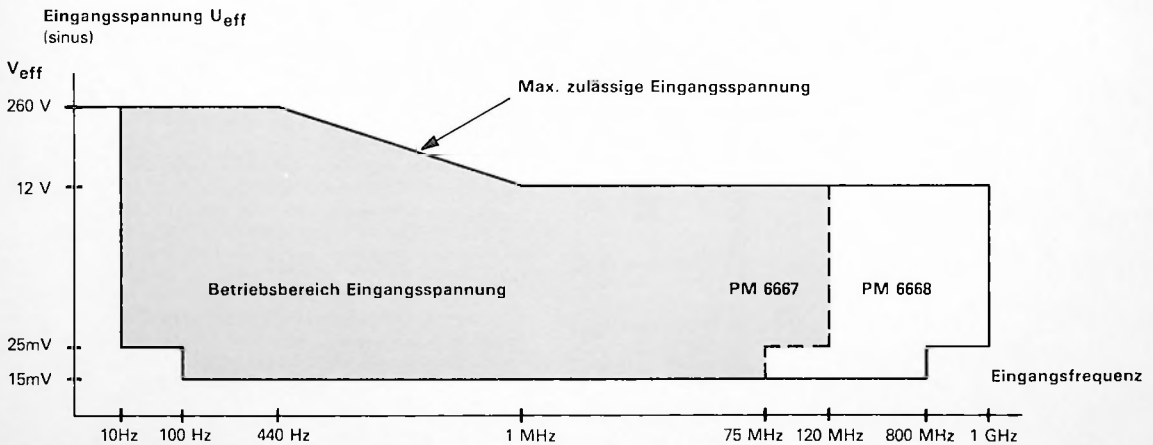

Frequenzbereich

PM 6667: 10Hz ... 120MHz

PM 6668: 10Hz ... 1GHz

Eingangsempfindlichkeit

(in Stellung 15mV_{eff})

NF-Eingang: 15mV_{eff} sinus;
100Hz ... 75MHz

25mV_{eff} sinus;
10Hz ... 120MHz

45mV_{SS} für Impulse mit
einer Dauer von ≥ 7 ns

HF-Eingang: (nur PM 6668)

15mV_{eff} sinus;
70MHz ... 800MHz

25mV_{eff} sinus;
800MHz ... 1GHz

(siehe Eingangsspannungs-
Charakteristik)

Eingangsabschwächung

NF-Eingang: 6 Schaltstellungen von x 1
bis x 300

HF-Eingang: Automatische Abschwächung

Triggerpegel

Eine feste Spannung (+, 0 oder -) sorgt automatisch für korrekte Triggerung bei jeder Signalform und jedem Tastverhältnis.

Kopplung: AC

Eingangsimpedanz

NF-Eingang: 1M Ω // \approx 25pF

HF-Eingang: 50 Ω Nennwert bei Stehwellenverhältnis VSWR < 2
(nur PM 6668)

Auflösung und Triggerfehler

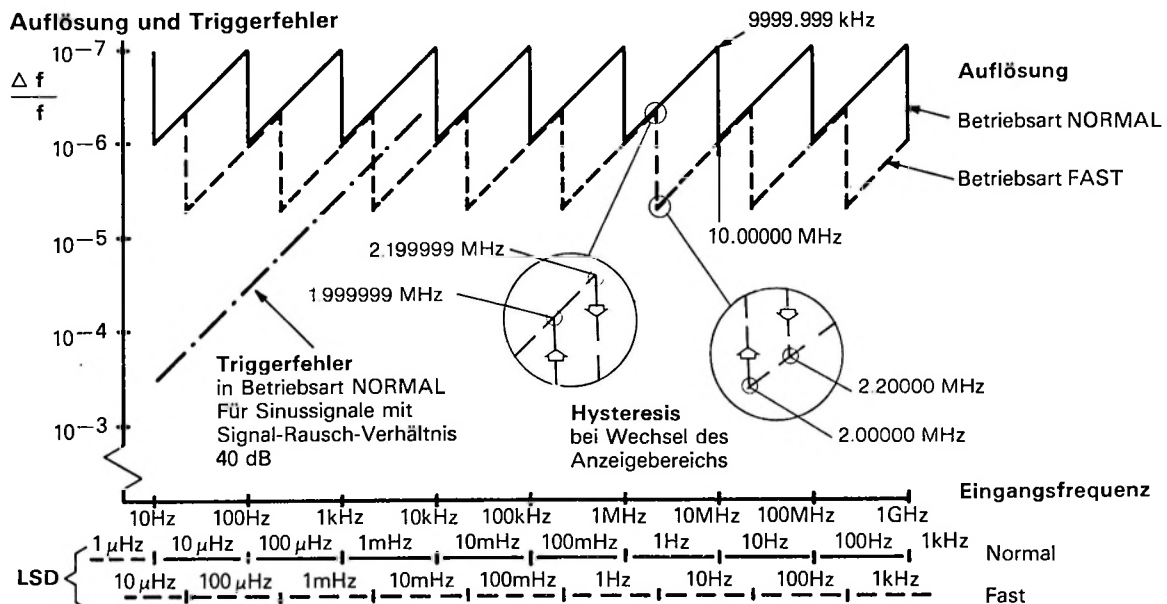

Maximal zulässige Eingangsspannung

DC: 300V
 AC: $U_{eff} = 260V$ (bei $\leq 440Hz$), fallend auf 12V (bei 1 MHz) (siehe Eingangsspannungscharakteristik)

Messgeschwindigkeit

Normal: ca. 1 Messung/s
 Fast: ca. 5 Messungen/s. Bei Frequenzen von unter 100Hz verringert sich die Messgeschwindigkeit allmählich bis auf eine Messung je Sekunde, um den Einfluss des Triggerfehlers auszugleichen.

Anzeige

7 digits (Ziffernhöhe 11,5 mm), Flüssigkristalle mit Anzeige von Dimension (Hz, kHz, MHz) und Batterieladestatus (LO BAT).

Fehlergrenze (relativer Frequenzfehler)

$$\pm \frac{LSD^*}{\text{Eingangsfrequenz}} \pm \text{Rel. Triggerfehler}^{**} \pm \text{Zeitbasisfehler}$$

* Digit niedrigster Wertigkeit = LSD = Least Significant Digit

** Rel. Triggerfehler:

Für beliebige Signalformen:

$$\frac{\text{Messgeschwindigkeit}}{\text{Signallanke (V/s)}} \times \frac{\text{Spitzenwert der Rauschspannung}}{\text{Spitzenwert der Rauschspannung}}$$

Für Sinussignale:

Messgeschwindigkeit

$$\text{Eingangsfrequenz} \times \pi \times S/N^{***}$$

*** Signal/Rauschverhältnis

Beispiel: Bei einem Signal-Rausch-Verhältnis (S/N) von 100 (40dB) und einer Messgeschwindigkeit von 1 Messung/s beträgt der Triggerfehler:

$$3 \times 10^{-3}$$

Eingangsfrequenz

Auflösung

Digit niedrigster Wertigkeit (LSD) und relative Auflösung (siehe Diagramm).

Externer Referenzeingang

Frequenz: 10 MHz

Eingangsspannung U_{eff} : 0,5V...12V

Eingangsimpedanz: ca. 2kΩ

Speisung

115/230V, $\pm 15\%$, 50...60Hz; 15VA oder durch wahlweise eingebaute Batterieeinheit PM 9601 oder durch externe 12V-Batterie.

Zeitbasischarakteristik

Zeitbasis	/01 (Standard)	/02 (TCXO)*
Kristallfrequenz	10MHz	10MHz
Alterung	$\leq 5 \times 10^{-7}$ /Monat	$\leq 1 \times 10^{-7}$ /Monat
Temperaturstabilität		
0...50°C, bez. auf +25°C	$\leq 1 \times 10^{-5}$	$\leq 1 \times 10^{-6}$
20...30°C, bez. auf +25°C	$\leq 3 \times 10^{-6}$ (typisch)	$\leq 3 \times 10^{-7}$ (typisch)

* TCXO = Temperaturkompensierter Kristalloszillator

Sicherheitsvorschriften

Nach IEC 348 und CSA 556 B.

Netzstörungen

Niedriger als Klasse II
 CENELEC/CISPR

Abmessungen und Gewicht

Breite: 160 mm
 Höhe: 77 mm
 Tiefe: 180 mm
 Gewicht: 1,2 kg

Umgebungsbedingungen

Temperatur

Lagerung: $-40^{\circ}C \dots +70^{\circ}C$
 Betrieb: $0^{\circ}C \dots +45^{\circ}C$

Höhe/Luftdruck

Lagerung: 15000 m/15,2 kN/m²
 Betrieb: 5000 m/53,3 kN/m²

Feuchtigkeit

10% ... 90% rel. Luftfeuchtigkeit (Taupunkt 26°C)

Vibration:

Stoßfestigkeit: entspr. IEC 68 Eb
 Handierung: entspr. IEC 68 Ec
 Transport: entspr. NLN - L88

3. Zubehör

3.1. Mitgeliefertes Standardzubehör

- Netzkabel
- Betriebsanleitung

3.2. Wahlweises Zubehör (gesondert zu bestellen)

- PM 9601 Batterie-/Ladeeinheit
- PM 9602 Tragtasche
- PM 9603 19"-Einbau-Adapter
- PM 9665 B 50-kHz-Tiefpassfilter, BNC—BNC
- PM 9236 1:10 Tastkopf 15 MHz, 10 MOhm
- PM 8935 1:10 Tastkopf 250 MHz, 10 MOhm
- Batteriebuchse (siehe Abschnitt 5 und 7.5 dieser Betriebsanleitung)

4. Batterieeinheit PM 9601

4.1. Allgemeines

Die PM 9601 ist eine wiederaufladbare Batterie-/Ladeeinheit zum Einbau in die Zähler PM 6667 und PM 6668.

Die Einheit enthält gasdichte 6V Bleiakkumulatoren sowie Steuerkreise für Ladung und Überladungsschutz.

Die Batterie-/Ladeeinheit wird mit vier Schrauben am metallenen Innenrahmen des Gehäuses befestigt (siehe Montageanleitung).

Es können Standardakkus verschiedener Hersteller verwendet werden. Ersatzakkus erhalten Sie im Fachhandel:

Hersteller	Ursprungsland	Typ	Kapazität
Sonnenschein*	Westdeutschland	3GX3S	3 Ah
Varta*	Westdeutschland	Accu Pb30704063	3 Ah
Gold Gelyte	USA	Pb 626-1	2,6 Ah
Elpower	USA	Ep 626A-6	2,6 Ah
SAFT*	Frankreich	PA 601	4 Ah
Kono	Japan	6-26k	2,6 Ah

* Empfohlene Marke

WARNUNG

Wiederaufladbare Batterien verlieren an Kapazität, wenn sie nicht benutzt oder nur selten wiederaufgeladen werden. Beachten Sie daher genau die Lagerungsvorschriften!

4.2. Wiederaufladung

Die Batterie wird automatisch wiederaufgeladen, wenn der Zähler ans Netz angeschlossen ist und der Netzschalter auf OFF steht.

Erscheint auf der Anzeige "LO BAT", bleiben noch 15 Minuten Betriebszeit, bevor die Batterie wiederaufgeladen werden muss.

Bei Ausfall der Netzspannung schaltet der Zähler automatisch auf die interne Batterie um.

Zum Abschalten des Geräts immer den Netzschalter benutzen, nicht das Netzkabel! Dadurch vermeidet man eine unerwünschte Entladung der Batterie ausser Betrieb.

Wiederaufladedauer (typischer Wert bei 20°C) 10h auf 90% der vollen Kapazität, 5h auf 70% der vollen Kapazität.

4.3. Lagerung

Vermeiden Sie es, völlig entladene Batterien zu lagern.

Wenn das Gerät ausser Betrieb ist, Netzschalter auf OFF stellen, das Netzkabel jedoch stecken lassen. Die Batterie bleibt dann immer voll aufgeladen und betriebsbereit. Falls das Gerät nicht ans Netz angeschlossen werden kann oder die Batterie ausserhalb des Geräts gelagert wird, empfehlen wir eine 5—10stündige Aufladung alle 3 Monate.

Bei längerer Lagerung die Sicherung aus der Batterieeinheit herausnehmen und die Batterie kühl und trocken lagern.

WARNUNG

Ständige Verwendung und Lagerung bei hohen Temperaturen beeinträchtigt die Lebensdauer der Batterie.

Längerdauernder Betrieb und Lagerung bei über +40°C sowie Ladung bei über +35°C sollten vermieden werden.

Zur Lagerung bei -40°C ist die Batterie auf mindestens 75% der vollen Kapazität aufzuladen.

Im übrigen gelten dieselben Umgebungsbedingungen wie für den Zähler selbst.

Gewicht der Batterieeinheit: 0,75 kg.

Sicherung: 1,6 A flink.

5. Externe Batterie

Für den Betrieb des Zählers kann eine externe 12V-Batterie verwendet werden. Dazu ist der rückwärtige BNC-Anschluss wie in Abschnitt 7.5 beschrieben durch eine Batteriebuchse zu ersetzen.

ZUR BEACHTUNG

Batteriebuchse und zugehöriger Stecker sind kostenlos erhältlich von:

Philips GmbH
z. Hd. Herrn Köbisch
Abtlg. VGE
Postfach 310 320
3500 Kassel

Bitte geben Sie Typennummer und Seriennummer Ihres Geräts an.

6. Sicherheitsvorschriften

(nach IEC 348)

Vor dem Anschluss des Geräts an das Netz sind Gehäuse, Bedienungsorgane, Buchsen usw. auf etwaige Transportschäden zu überprüfen.

Werden Schäden bemerkt, darf der Zähler nicht ans Netz angeschlossen werden. Das Gerät muss von sämtlichen Spannungsquellen getrennt werden und alle etwaigen Hochspannungskapazitäten sind zu entladen, bevor Wartungs- bzw. Reparaturarbeiten vorgenommen werden.

Abgleich- oder Wartungsarbeiten, bei denen das Gerät angeschlossen und geöffnet sein muss, dürfen nur von Fachpersonal ausgeführt werden, das sich der bestehenden Gefahr bewusst ist.

ZUR BEACHTUNG

Sämtliche Teile auf der Primärseite des Transformators sind CSA-geprüft und sollten nur durch Originalteile ersetzt werden.

7. Inbetriebnahme

7.1. Netzanschluss

Überprüfen Sie vor Anschluss des Geräts, dass es auf die örtliche Netzspannung eingestellt ist. Bei Lieferung ist der Zähler auf 115V oder 230V $\pm 15\%$ eingestellt – abzulesen auf der Geräterückseite. Muss eine andere Spannung eingestellt werden, wenden Sie sich bitte an Ihre Servicedienststelle. Das Service-Handbuch enthält die notwendigen Anleitungen.

7.2. Interner und externer Standard

Durch Umstecken der Verbindung DV101 lässt sich der Zähler auf (siehe Abbildung unten) externen oder internen Standard einstellen.

Bei Lieferung ist der Zähler auf internen Standard eingestellt.

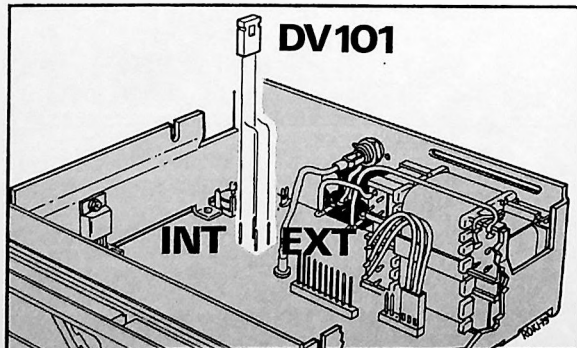

7.3. Erdung

Das Gerät ist über das 3adrige Netzkabel geerdet, das an eine Schutzkontakt-Steckdose anzuschließen ist.

Keine andere Form der Sicherheitserdung ist erlaubt.

7.4. Einbau der Batterie-/Ladeeinheit PM 9601

- Zählerdeckel abnehmen.
- Obere Schutzplatte abnehmen.
- +5V-Regler IC 112 ausbauen (siehe Abbildung unten).
- Batterieeinheit wie auf der Abbildung unten gezeigt einsetzen. Drähte von der Batterie zur Leiterplatte an den Batteriekanten entlang führen.
- Neue Abdeckung wie auf der Abbildung gezeigt aufstecken und mit zwei Schrauben seitlich am Chassis befestigen.
- Einheit seitlich am Chassis festschrauben.

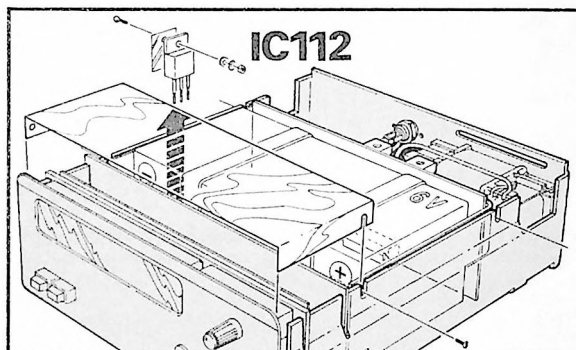

7.5. Buchse für externe Batterie

Der rückwärtige BNC-Anschluss für externen Standard kann durch eine Buchse für externe Batterieversorgung ersetzt werden. Die Buchse passt für DIN 45323.

Um den BNC-Anschluss gegen die Batteriebuchse auszutauschen, geht man wie folgt vor:

- Koaxialkabel von der Leiterplatte losmachen und den Mittelleiter vom BNC-Anschluss ablöten.
- BNC-Anschluss gegen Batteriebuchse austauschen und den zweipoligen Verbindungsstift so anschließen, wie es der Polarität Ihres Batteriesteckers entspricht. Vgl. Abbildung unten.

Der zweipolige Verbindungsstift (p/o BU 107) ist diodengeschützt, um Beschädigungen durch falsche Polarität zu verhindern.

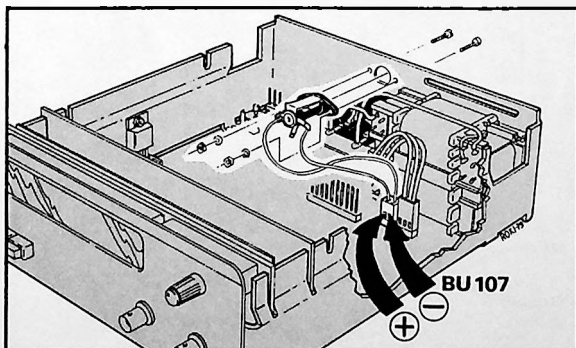

8. Bedienungsorgane und Anschlüsse

POWER ON

Ein-/Ausschaltung des Zählers. ACHTUNG: Es ist dies kein vollständiger Netzschalter. Auch in Stellung POWER OFF hat der Zähler spannungsführende Teile und Leiter. Um das Gerät völlig vom Netz zu trennen, muss das Netzkabel gezogen werden.

Bei Netzausfall schaltet der Zähler automatisch auf Batterie- speisung um.

MEASUREMENT RATE

Einstellung auf eine von zwei Messgeschwindigkeiten: NORMAL (Taste gelöst) oder FAST (Taste gedrückt).

NORMAL bedeutet etwa 1 Messung/s und FAST etwa 5 Messungen/s. Die Messgeschwindigkeit in Stellung FAST verringert sich bei niedrigen Frequenzen bis auf etwa 1 Messung/s bei 10 Hz.

SENSITIVITY

Einstellung der Empfindlichkeit in 6 Stufen von 15mV_{eff} bis 5V_{eff} .

ZUR BEACHTUNG: Nie auf höhere Empfindlichkeit als notwendig einstellen, um Rausch- und Störeinflüsse so gering wie möglich zu halten.

NF-Eingang

Hochohmiger (1 MOhm), AC-gekoppelter Eingang für Signale mit einer Frequenz von 10 Hz bis 120 MHz. Ein **Auto-Triggerkreis** gewährleistet korrekte Triggerung bei Sinus- signalen und Impulsen mit beliebigem Tastverhältnis.

HF-Eingang (PM 6668)

Niedrigohmiger (50 Ohm), AC-gekoppelter Eingang für Sinus- signale mit einer Frequenz von 70 MHz bis 1 GHz.

Der Mikrocomputer des Zählers registriert das Vorhanden- sein von HF-Signalen und wählt automatisch diesen Ein- gang, wenn die Frequenz genügend hoch ist. Dadurch ist es möglich, dasselbe Signal über ein T-Stück an beide Ein- gänge zu legen. Siehe Abbildung unten.

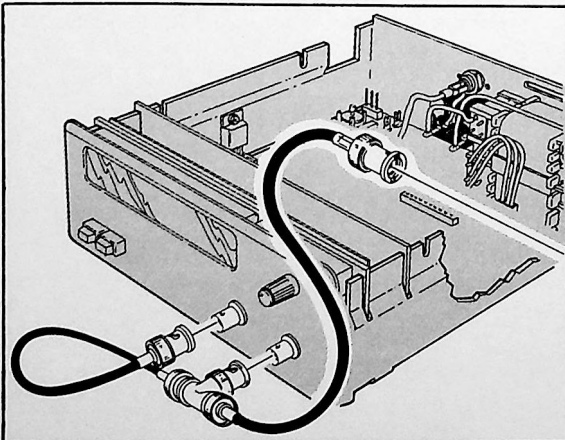

Bei wechselnder Frequenz, wie z.B. der Messung von Fre- quenzhuben, schaltet der Zähler dann selbsttätig zwischen den beiden Eingängen um.

Weitere Einzelheiten über das Eingangssignal finden Sie im Abschnitt "Technische Daten".

EXTERNER STANDARD oder BATTERIE

BNC-Anschluss für externe Zeitbasis oder — als wahlweiser Zusatz — Buchse für externe Batterie.

Netzeingang

Anschluss der Netzspannung. Immer das mitgelieferte 3adrige Netzkabel verwenden.

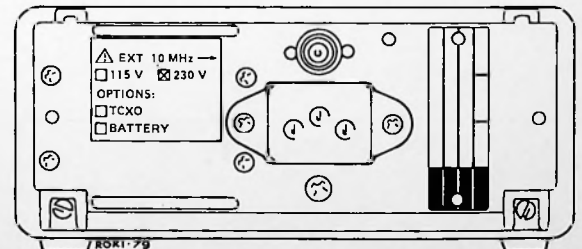
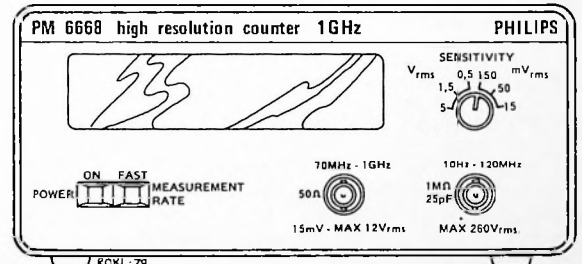
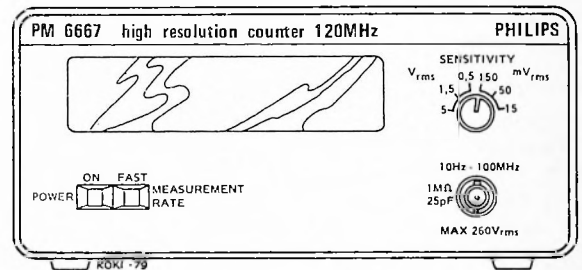



PHILIPS

Notice d'emploi

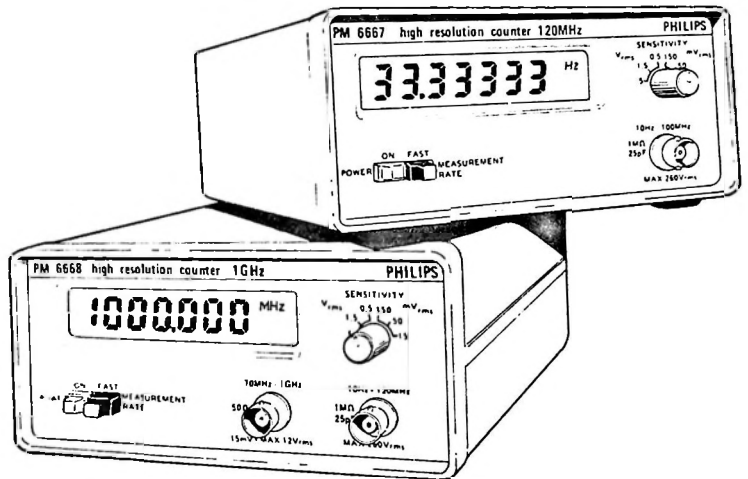

N.V. PHILIPS' GLOEILAMPENFABRIEKEN — EINDHOVEN — THE NETHERLANDS — 1980

Printed in Sweden

1. Introduction

Le PM 6667 et le PM 6668 sont des fréquencemètres à micro-processeur offrant une gamme de fréquence respectivement de 10 Hz ... 120 MHz (PM 6667) et de 10 Hz ... 1 GHz (PM 6668).

En mesure de fréquence, l'utilisation du micro-calculateur permet d'éliminer l'erreur traditionnelle de ± 1 cycle. En effectuant une mesure en période multiple et en calculant la valeur réciproque, ces compteurs fournissent une très haute résolution même sur des signaux en basse fréquence.

L'avantage de l'utilisation du micro-calculateur dans ces compteurs est la sélection automatique de gammes. Le résultat d'une mesure est toujours affiché avec un maximum de résolution, sans dépassement et avec l'indication appropriée de l'unité: Hz, kHz, MHz et point décimal.

Il offre le choix entre deux cadences de mesure: NORMAL,

avec une résolution de 7 chiffres par seconde, ou RAPIDE (fast) avec une résolution de 6 à 7 chiffres toutes les 200 ms. Le mode rapide est utilisé pour l'observation des fréquences variables et pour les réglages de ces fréquences.

Les options suivantes sont offertes: une base de temps plus stable, avec TCXO (version 02), un bloc batterie rechargeable PM 9601 (monté à l'intérieur de l'appareil), une malette de transport PM 9602 et un adaptateur PM 9603 pour montage sur panneau ou rack 19".

Le cadran à 7 chiffres à cristal liquide contient les voyants de l'unité de mesure et la virgule décimale.

Après la mise en marche, l'appareil effectue un programme d'auto-contrôle. Au cours de celui-ci, si une erreur apparaît, elle est aussitôt détectée et affichée suivant le code de diagnostic.

AVERTISSEMENT

Avant de brancher l'appareil au secteur, lire attentivement les mesures de sécurité décrites en page 17.

2. Caractéristiques techniques

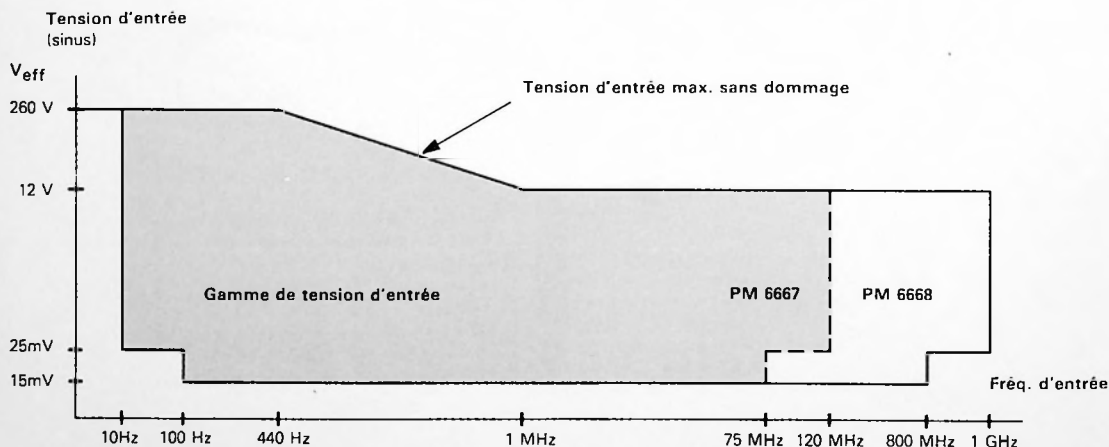

Gamme de fréquence

PM 6667: 10Hz ... 120MHz
PM 6668: 10Hz ... 1GHz

Sensibilité d'entrée

(en position 15mV_{eff})

Entrée BF: 15mV_{eff} (sinus)
100Hz ... 75MHz

25mV_{eff} (sinus)
10Hz ... 120MHz

45mVc à c pour impulsions de largeur ≥ 7 ns

Entrée RF: (PM 6668 seulement)

15mV_{eff} (sinus)
70MHz ... 800MHz

25mV_{eff} (sinus)
800MHz ... 1GHz

(voir caractéristiques des tensions d'entrées)

Atténuation d'entrée

Entrée BF: x 1 à x 300 en 6 positions

Entrée RF: atténuation automatique

Niveau de déclenchement

Fixe (+, 0 ou -) la tension est appliquée automatiquement pour assurer le déclenchement, quels que soient la forme et le rapport cyclique du signal.

Couplage: CA

Impédance d'entrée

Entrée BF: 1M Ω // \approx 25pF nominal
Entrée RF: 50 Ω nominal avec un TOS < 2 (PM 6668 seulement)

Résolution et erreur de déclenchement

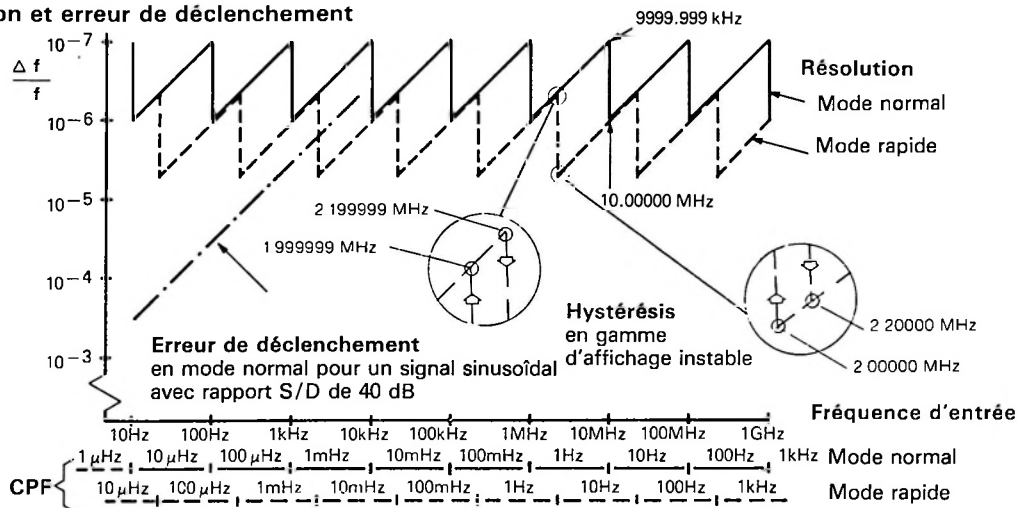

Tension d'entrée max.

CC: 300V

CA: 260V_{eff} de 10Hz à 440Hz, descend régulièrement jusqu'à 12V_{eff} à 1 MHz (voir caractéristiques de la tension d'entrée ci-dessus).

Cadence de mesure

Normale (sortie): approx 1 mesure/s
Rapide (entrée): approx 5 mesures/s*

* aux fréquences inférieures à 100Hz, la cadence de mesure descend graduellement en dessous de 1 mesure/s pour réduire l'erreur due au déclenchement.

Affichage

Affichage à cristaux liquides de 7 chiffres de 11,5 mm avec indication de l'unité: Hz, kHz, MHz et "LO-BAT".

Précision (erreur relative de fréquence)

$\pm \frac{\text{CPF}}{\text{Fréquence d'entrée}} \pm$ err. relat. de déclench. **

\pm erreur de base de temps

** Erreur relative de déclenchement:

Pour toutes formes d'ondes:

$\frac{\text{Cadence de mesure}}{\text{Pente du signal (V/s)}} \times \text{tension de bruit c. à c.}$

Pour ondes sinusoïdales:

$\frac{\text{Cadence de mesure}}{\text{Fréquence d'entrée} \times \pi \times \text{rapport S/B}}$

Exemple: pour un rapport S/B de 100 (40dB) et une cadence de mesure de 1 par Sec.

L'erreur de déclenchement est de:

$$3 \times 10^{-3} \text{ fréquence d'entrée}$$

Résolution

Pour le chiffre de poids le plus faible (CPF), la résolution relative est donnée par le graphique ci-haut.

Entrée référence extérieure

Fréquence: 10MHz
Gamme de tension: 0,5V_{eff}...12V_{eff}
Impédance: approx. 2kΩ

Alimentation

115/230V, $\pm 15\%$, 50 ... 60Hz, 15VA ou par batterie extérieure 12V, ou par bloc batterie interne (option) type PM 9601.

Dimensions et poids

Largeur: 160 mm
Hauteur: 77 mm
Profondeur: 180 mm
Poids: 1,2 Kg

Caractéristiques des bases de temps

Version	/01 (standard)	/02 (TCXO)
Fréquence du cristal	10MHz	10MHz
Stabilité/temps	$\leq 5 \times 10^{-7}$ /mois	$\leq 1 \times 10^{-7}$ /mois
Stabilité/température		
0 ... 50°C réf. à 25°C	$\leq 1 \times 10^{-5}$	$\leq 1 \times 10^{-6}$
20 ... 30°C réf. à 25°C	$\leq 3 \times 10^{-6}$ (typiques)	$\leq 3 \times 10^{-7}$ (typiques)

Conditions d'environnement

Température:

Stockage: $-40^{\circ}\text{C} \dots +70^{\circ}\text{C}$
Fonctionnement: $0^{\circ}\text{C} \dots +45^{\circ}\text{C}$

Pression barométrique/altitude:

Stockage: 15000 m
/15,2kN/m²
Fonctionnement: 5000 m
/53,3kN/m²

Humidité:

10% ... 90% RH
(point de rosée 26°C)

Vibrations:

conforme IEC 68 Fc
Chocs: conforme IEC 68 Eb
Manutention: conforme IEC 68 Ec
Transport: conforme NLN - L88

Alimentations:

115/230V, $\pm 15\%$ 50 ... 60 Hz, 15 VA ou par unité de batterie incorporée, en option.

Sécurité

Conforme aux normes IEC 348 et CSA 556 B.

Interférences Secteur

Inférieures à la classe II CENELEC/CISPR.

3. Accessoires

3.1. Accessoires standards (fournis avec l'appareil)

- Un cordon secteur.
- Une notice d'emploi.

3.2. Accessoires en option (à commander séparément)

- Une unité de batterie PM 9601.
- Une malette de protection PM 9602.
- Un adaptateur de montage PM 9603 sur panneau/rack 19".
- Une sonde d'atténuation 10 Mohm, 15 MHz, PM 9236.
- Une sonde d'atténuation 10 Mohm, 250 MHz, PM 8935.
- Une fiche batterie (voir sections 5 et 7.5 de ce manuel).
- Un filtre passe-bas, 50KHz BNC—BNC, PM 9665 B.

4. Unité de batterie PM 9601

4.1. Généralités

La PM 9601 est une unité de batterie rechargeable, pouvant être montée à l'intérieur des compteurs PM 6667 et PM 6668.

Cette unité contient une batterie normale et étanche de 6V, au gel d'acide de plomb. Elle contient en plus, un circuit de protection de charge et de surcharge.

L'unité de batterie est mise en place avec quatre vis, sur un panneau métallique à l'intérieur du coffret. (Voir les instructions de montage.) La batterie étant standard, est disponible sur le marché et chez de nombreux fabricants. Pour obtenir des batteries de rechange, contacter directement votre fournisseur, qui dispose de batteries fraîches et chargées à point.

Fabricant	Pays d'origine	Type	Capacité
Sonnenschein*	Allemagne Féd.	3GX3S	3 Ah
Varta*	Allemagne Féd.	Accu Pb30704063	3 Ah
Gold Gelyte	Etats-Unis	Pb 626-1	2.6 Ah
Elpower	Etats-Unis	Ep 626A-6	2.6 Ah
SAFT*	France	PA 601	4 Ah
Kono	Japon	6-26k	2.6 Ah

* Marque recommandée

AVERTISSEMENT

La capacité des batteries rechargeables se dégrade quand les batteries ne sont pas utilisées ou rechargées fréquemment. Lire alors attentivement les instructions de stockage du fabricant.

4.2. Recharge

La batterie est rechargée automatiquement pendant que le compteur est branché au secteur, même si l'appareil n'est pas en fonctionnement.

Quand l'affichage indique la tension basse (LO BAT), il reste encore 15 minutes de charge avant qu'une recharge soit nécessaire.

En cas d'une panne secteur, la batterie alimente automatiquement le compteur.

Pour prévenir toute décharge indésirable des batteries pendant que le compteur reste hors d'usage, se servir toujours du commutateur de tension pour interrompre l'alimentation, et non le cordon secteur.

Temps de recharge (typique à 20°C): 90% de la capacité totale en 10 heures, et 70% de la capacité totale en 5 heures.

4.3. Stockage

Eviter le stockage de batteries complètement déchargées. Quand l'appareil reste hors d'usage, mettre le commutateur de tension en position fermée "OFF" mais laisser l'appareil branché au secteur. La batterie sera alors chargée à point et toujours prête à l'usage. Au cas où la batterie est stockée à l'extérieur de l'appareil, ou quand l'appareil ne peut pas être branché au secteur, il est recommandé de recharger la batterie durant 5 à 10 heures tous les trois mois.

En cas d'une plus longue période de stockage, retirer le fusible dans l'unité de batterie et tenir la batterie au frais et au sec.

AVERTISSEMENT

L'usage permanent et le stockage sous de hautes températures, affectent défavorablement la longévité de la batterie.

Eviter le stockage et l'usage prolongés sous une température supérieure à +40°C et ainsi que la charge sous une température supérieure à +35°C. Pour le stockage à une température de -40°C, la batterie doit être chargée au moins à 75% de sa capacité totale.

Les autres conditions d'environnement sont identiques à celles du compteur.

Poids additionnel de l'unité de batterie: 0.75 Kg.

Fusible: 1.6A action rapide.

5. Batterie externe

Une batterie externe peut être utilisée pour alimenter le compteur. Remplacer le connecteur BNC à l'arrière par une fiche batterie comme décrit à la section 7.5. de ce manuel.

NOTE

Pour obtenir gratuitement une fiche batterie, écrire à:

SA. Philips Industrielle et Commerciale
Division Sciences et Industrie
105 Rue de Paris
93002 BOBIGNY
Tel. 830 11 11

Indiquer s.v.p., les numéros de type et de série de votre appareil.

6. Mesures de sécurité

(conformes à la norme IEC 348)

Avant de brancher l'appareil au secteur, examiner attentivement le coffret, les organes de commande et les connecteurs etc., afin de s'assurer que l'appareil n'a subi aucun dommage durant le transport ou le stockage.

Un défaut quelconque étant constaté, ne pas brancher l'appareil au secteur. Débrancher l'appareil de toute source d'alimentation et décharger tout point de connexion sous haute tension avant d'entreprendre l'entretien ou la réparation.

S'il est inévitable d'enlever les capots du compteur pour procéder à des ajustements ou à une maintenance de l'appareil en opération, alors confier le travail à un personnel qualifié et au courant des risques impliqués.

NOTE

Toutes les pièces se trouvant sur le coté primaire du transformateur sont reconnues par la CSA, et en cas de besoins devront être remplacées seulement par des pièces détachées d'origine. Le manuel d'entretien fournit les instructions utiles au réglage de la tension.

7. Installation

7.1. Raccordement secteur

Avant de brancher l'appareil au secteur, s'assurer qu'il est adapté à la tension secteur locale. A la livraison l'appareil est adapté à une gamme de 115V ou 230V $\pm 15\%$ selon l'indication sur le panneau arrière. Si l'appareil doit être adapté à une autre gamme de tension, contacter alors votre agent local.

7.2. Mise à la terre

L'appareil est mis à la terre par le cordon secteur à trois conducteurs, enfiché dans une prise secteur comportant une terre. Il est interdit d'avoir recours à d'autres méthodes de mise à la terre.

7.3. Etalon interne et externe

Le compteur peut être adapté à un étalon interne ou externe en utilisant le connecteur amovible DV 101, comme dans l'illustration ci-dessous.

A la livraison, le compteur est adapté à un étalon interne.

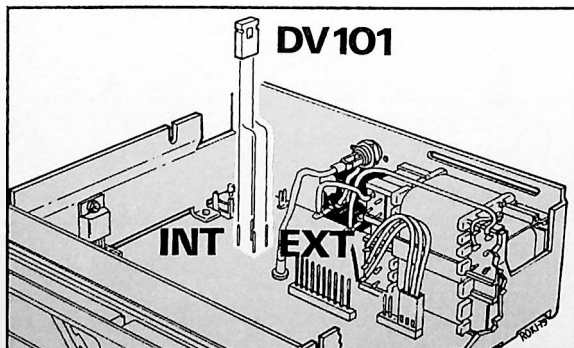

7.4. Unité de batterie interne PM 9601

- Enlever le capot du compteur.
- Enlever le panneau de blindage supérieur.
- Enlever le régulateur +5V IC 112 (voir ci-dessous).
- Placer ensuite l'unité de batterie comme dans la figure ci-dessous. Placer les conducteurs allant de la batterie jusqu'à la plaquette cuivrée sur les bords de la batterie.
- Monter le nouveau panneau de blindage comme indiqué dans la figure ci-dessous et en assurer la fixation aux panneaux latéraux du compteur avec 2 vis.
- Assurer enfin la mise en place de l'unité, aux panneaux latéraux du compteur avec des vis.

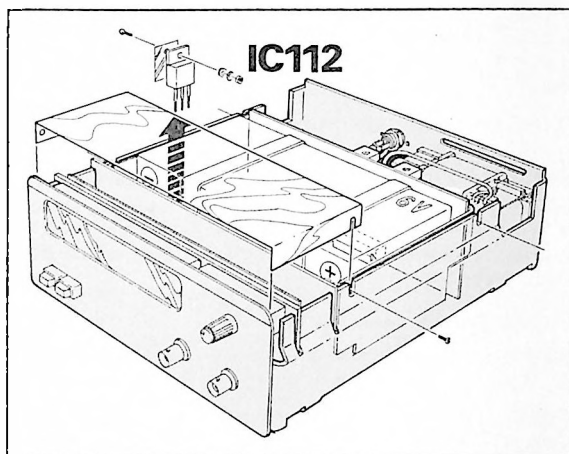

7.5. Fiche batterie externe

Le connecteur BNC à l'arrière, pour étalon externe, peut être remplacé par une fiche batterie pour alimentation batterie externe. La fiche correspond à la norme DIN 45323.

Pour remplacer le connecteur BNC par une fiche batterie, procéder comme suit:

- Détacher le câble coaxial de la plaquette cuivrée, et désolder le conducteur central du connecteur BNC.
- Remplacer le connecteur BNC par une fiche batterie, et enficher le connecteur à double-pôles de façon à ce qu'il coïncide avec la polarité de votre fiche batterie. Voir la figure ci-dessous.

Le connecteur à deux pôles (p/o BU 107) contient une diode de protection contre tout changement de polarité.

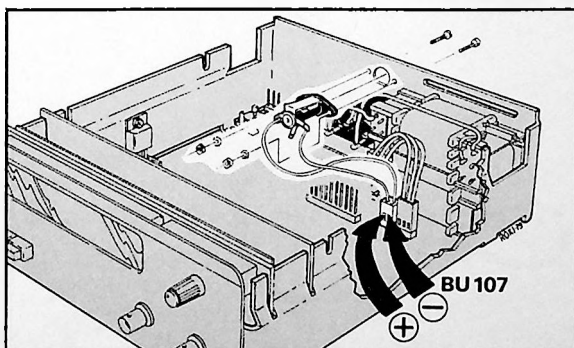

8. Organes de commande et Connecteurs

POWER ON

Permet la mise en route (ON) et la mise hors service (OFF) du compteur. ATTENTION: C'est un commutateur secondaire d'alimentation. Même en position POWER OFF le compteur contient toujours des conducteurs et pièces sous tension. Pour interrompre complètement l'alimentation du compteur, débrancher le cordon secteur. En cas d'une panne secteur, la batterie alimente automatiquement le compteur.

MODE DE MESURE (measurement rate)

Réglage du mode de mesure sur un des deux cadences de mesure NORMAL (position relâchée) ou FAST (rapide, position enfoncée). NORMAL signifie 1 mesure/seconde et FAST (rapide) signifie 5 mesures/seconde. En mode FAST (rapide) la vitesse diminuera jusqu'à 1 mesure/seconde aux fréquences basses telle que 10Hz.

SENSITIVITY (sensibilité)

Réglage de la sensibilité d'entrée en 6 gammes; de $15mV_{eff}$ à $5V_{eff}$.

NOTE: Pour réduire toute influence de bruits et d'interférences, ne jamais augmenter la sensibilité inutilement.

Entrée RF (PM 6668 seulement)

Une entrée à basse impédance (50 ohm) et à couplage capacitif, pour les signaux dont les fréquences sont de 70MHz à 1GHz.

Le micro-ordinateur du compteur détecte la présence d'un signal RF et le sélectionne automatiquement, quand le signal d'entrée est suffisamment important pour le comptage. En conséquence il est possible de coupler simultanément le même signal aux deux entrées, par un connecteur-T (voir la figure ci-dessous).

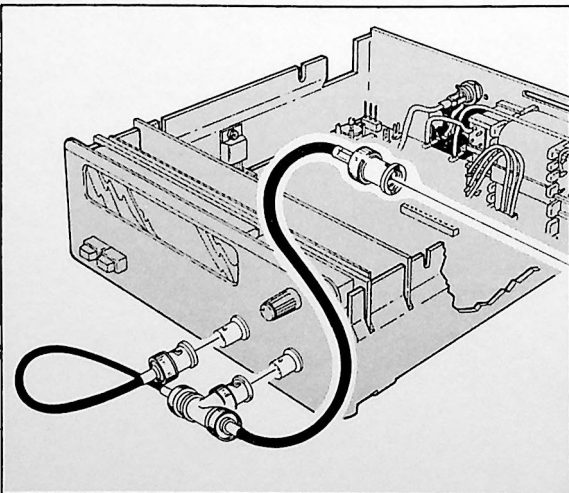

Le compteur sélectionnera alors automatiquement, l'une des deux entrées, selon le changement de fréquences, ex. — pour la mesure en balayage fréquences.

Pour de plus amples détails sur le signal d'entrée, voir Caractéristiques Techniques.

Entrée BF

Une entrée à haute impédance (1 Mohm) et à couplage capacitif, pour les signaux dont les fréquences sont de 10Hz à 120MHz. Un circuit à auto-déclenchement assure le déclenchement correct sur les sinusoïdales et les impulsions, quelque soit le rapport cyclique.

ETALON EXTERNE ou BATTERIE

Entrée BNC pour étalon base de temps externe, ou comme option supplémentaire, fiche batterie pour batterie externe.

Douille tension secteur

Entrée tension secteur. Se servir toujours du cordon secteur à trois conducteurs fourni avec le compteur.

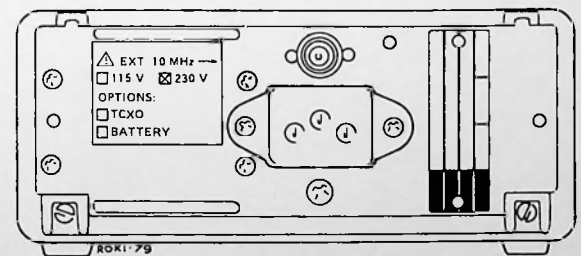
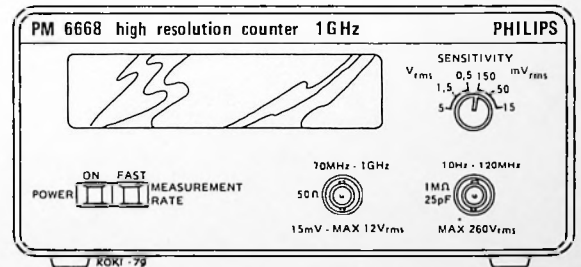
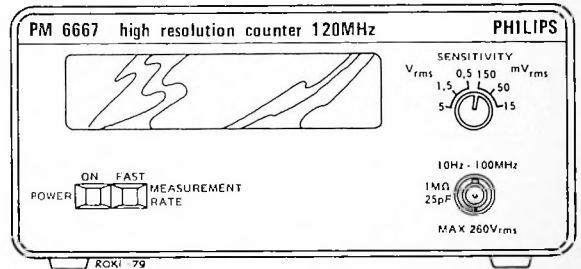



PHILIPS

Bruksanvisning

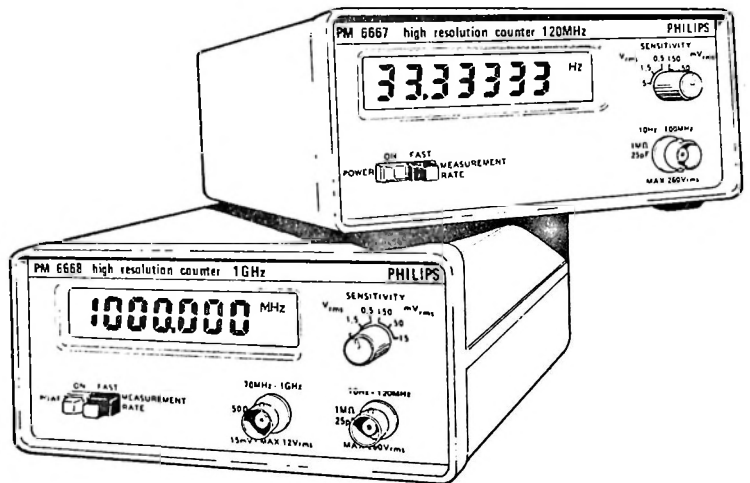

1. Inledning

PM 6667 och PM 6668 är mikrodatobaserade frekvensräknare för frekvensområdet 10 Hz ... 120 MHz (PM 6667) och 10 Hz ... 1 GHz (PM 6668).

Mikrodatorn i dessa räknare öppnar nya möjligheter för frekvensmätningar. Felmarginalen är nämligen ± 0 , mot traditionellt ± 1 . Genom att mäta ett multipelt periodantal och beräkna reciprokvärdet möjliggörs frekvensmätningar med hög upplösning även vid lågfrekventa signaler.

Ytterligare en fördel med PM 6667 och PM 6668 är automatisk inställning på rätt mätområde. Mätresultaten visas alltid med maximal upplösning utan överlopp, och med korrekt angivelse av Hz, kHz, MHz samt decimaltecken.

Det finns två mätastigheter att välja mellan: NORMAL med 7-siffrig upplösning varje sekund eller FAST med 6-siffrig eller 7-siffrig upplösning varje 200 ms. Driftsättet

FAST används för mätning av växlande frekvenser vid bl a tuning.

Följande extra tillbehör kan levereras: en stabilare tidsbas med TCXO (/02 version), ett laddningsbart batteri PM 9601 för montering i räknarna, en slagtälig bärväska PM 9602 och 19"-adapter för stativ- och panelmontage.

Räknarnas 7-siffriga display anger även mätenhet och decimaltecken.

Efter inkoppling genomför räknaren en självkontroll. Ev fel som därvid upptäcks indikeras med hjälp av en diagnostisk kod (Error 1–6).

OBS!

Läs igenom säkerhetsbestämmelserna på sida 23 innan instrumentet ansluts till nätspänningen!

2. Teknisk specifikation

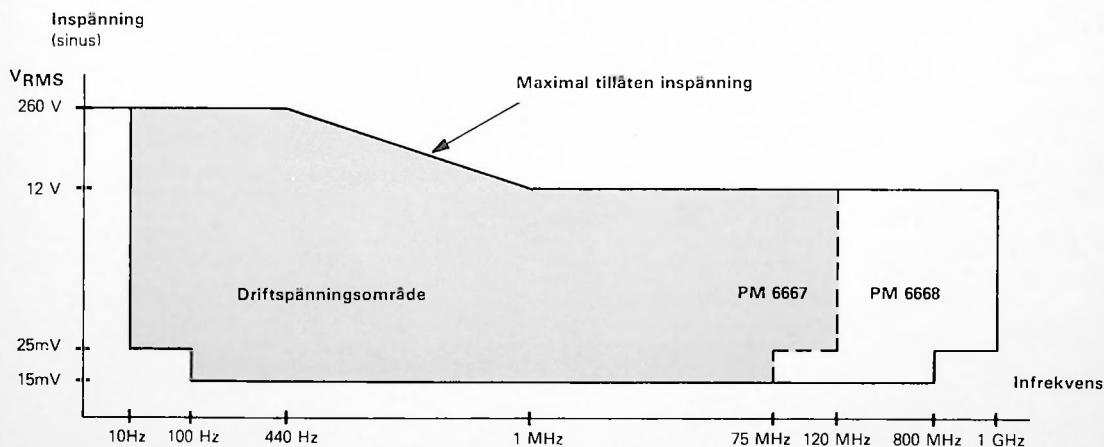

Frekvensområde

PM 6667: 10Hz ... 120MHz
PM 6668: 10Hz ... 1GHz

Ingångskänslighet

(vid inställning på 15mV_{eff})

LF-ingång: 15mV_{eff} sinus;
100Hz ... 75MHz

25mV_{eff} sinus;
10Hz ... 120MHz

45mV_{t-t} för pulser med
pulstid ≥ 7 ns

HF-ingång: 15mV_{eff} sinus;
(PM 6668) 70MHz ... 800MHz

25mV_{eff} sinus;
800MHz ... 1GHz

(se inspänningskaraktistik ovan)

Ingångsdämpning

LF-ingång: x 1 till x 300 i 6 steg
HF-ingång: automatisk dämpning

Triggnivå

En fast spänning (+, 0 eller -) ger automatiskt korrekt trigging vid god-

tyckliga kurvformer och pulsförhållanden (pulskvoter).

Koppling: AC

Ingångsimpedans

LF-ingång: 1M Ω // \approx 25pF

HF-ingång: 50 Ω nominellt med VSWR < 2 (endast PM 6668)

Max. tillåten inspänning

DC: 300V

AC: 260V_{eff} vid \leq 440Hz, minskande till 12V_{eff} vid 1 MHz (se inspänningskaraktistik ovan)

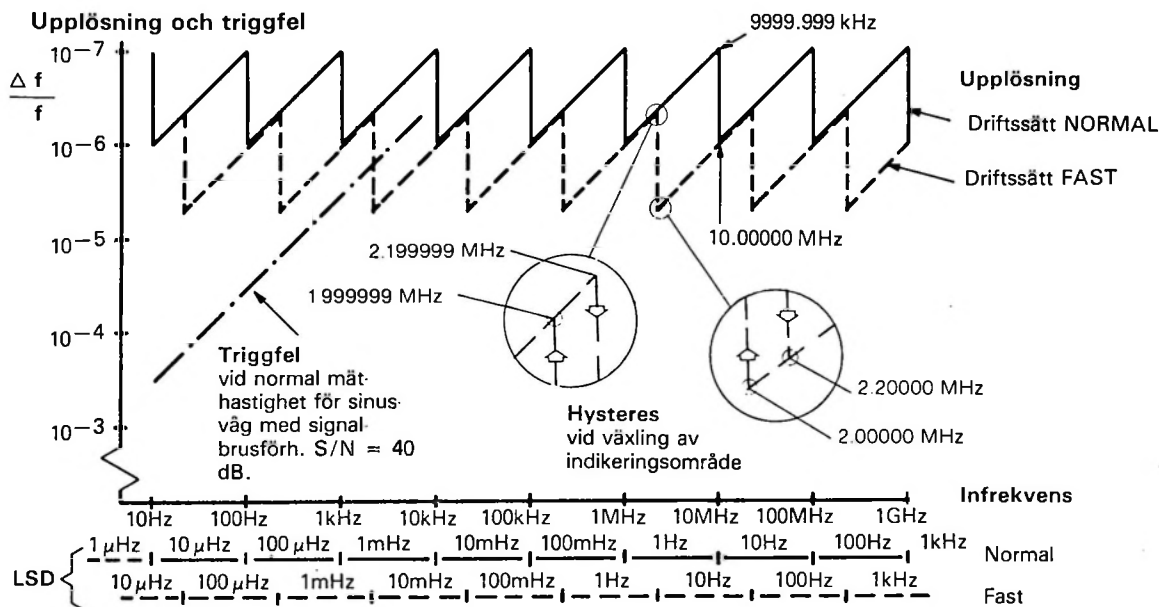

Mäthastighet

Normal: ca 1 mätning/s

Fast: ca 5 mätningar/s; vid frekvenser lägre än 100 Hz minskar mät-hastigheten stegvis ned till en mätning per sekund för att reducera triggelets inverkan.

Indikering

Flytande kristalldisplay (LCD), 7 siffror, höjd 11,5 mm. Indikering av mät-enheter Hz, kHz och MHz samt LO BAT (urladdat batteri).

Max mätfel (relativt frekvensfel)

$$\pm \frac{\text{LSD}}{\text{infrekvens}} \pm \text{rel. trigggfel} \pm \text{tidsbasfel}$$

Rel. trigggfel:

För godtyckliga vågformer:

Mäthastighet

Signalens flankbranthet V/s
x topp-till-topp brusspänning

För sinusformade signaler:

Mäthastighet

Infrekvens x π x S/N

Exempel: vid S/N (signal-brusförhållande) = 100 (40 dB) och 1 mätning/s är triggelet lika med

$$3 \times 10^{-3}$$

infrekvens

Upplösning

Betr minst signifikanta siffran (LSD, least significant digit) och relativ upplösning, se diagrammet ovan.

Extern referensgång

Frekvens: 10 MHz
Inspänning: 0,5V_{eff}...12V_{eff}
Ingångsimpedans: ca. 2kΩ

Nätanslutning, effektförbrukning

115/230V, ±15%, 50 ... 60Hz; 15VA eller genom inbyggt batteri, PM 9601, eller externt 12V-batteri.

Säkerhet

Enl IEC 348 och CSA 556 B.

Nätstörningar

Bättre än klass II CENELEC/CISPR

Tidsbaskarakteristik

Tidsbas	/01 (standard)	/02 (TCXO)
Extern frekvens	10 MHz	10 MHz
Åldring	$\leq 5 \times 10^{-7}$ /månad	$\leq 1 \times 10^{-7}$ /månad
Temperaturstabilitet		
0 ... 50°C, i förh. till 25°C	$\leq 1 \times 10^{-5}$	$\leq 1 \times 10^{-6}$
20 ... 30°C, i förh. till 25°C	$\leq 3 \times 10^{-6}$ (typiskt)	$\leq 3 \times 10^{-7}$ (typiskt)

Dimensioner och vikt

Längd: 160 mm
Höjd: 77 mm
Djup: 180 mm
Vikt: 1,2 kg

Omgivningsfaktorer

Temperatur:

Lagring: -40°C ... +70°C
Drift: 0°C ... +45°C

Höjd/lufttryck:

Lagring: 15000 m
/15,2kN/m²
Drift: 5000 m
/53,3kN/m²

Fuktighet:

10% ... 90% rel luftfuktighet (daggpunkt 26°C)

Vibrationsprov: enl IEC 68 Fc

Slagprov: enl IEC 68 Eb

Hanteringsprov: enl IEC 68 Ec

Transportprov: enl NLN - L88

3. Tillbehör

3.1. Standardtillbehör (följer med instrumentet)

- Nätkabel.
- Instruktionshäfte.

3.2. Extra tillbehör (att beställas separat)

- PM 9601 batterienhet.
- PM 9602 bärväska.
- PM 9603 19" adapter för rackmontage.
- PM 9665 B 50kHz-lågpassfilter, BNC—BNC.
- PM 9236 15 MHz, 10 Mohm-testprob (mätkropp).
- PM 8935 250MHz, 10 Mohm-testprob.
- Batterijack (se avsnitt 5 och 7.5 i detta instruktionshäfte).

4. Batterienhet PM 9601

4.1. Allmänt

PM 9601 är en laddningsbar batterienhet avsedd att monteras i räknarna PM 6667 och PM 6668.

Enheten innehåller ett 6 V gastätt blybatteri samt styrkretsar för laddning och skydd mot överladdning.

Batterienheten fästs med fyra skruvar på instrumentets inre metallram. (Se monteringsanvisningarna)

Batteriet är av standardtyp och det går att använda ett flertal olika märken. Färska och fullt uppladdade reservbatterier finns att köpa i fackhandeln.

Tillverkare	Ursprungs-land	Typ	Kapacitet
Sonnenschein*	V-tyskland	3GX3S	3 Ah
Varta*	V-tyskland	Accu Pb30704063	3 Ah
Gold Gelyte	USA	Pb 626-1	2.6 Ah
Elpower	USA	Ep 626A-6	2.6 Ah
SAFT*	Frankrike	PA 601	4 Ah
Kono	Japan	6-26k	2.6 Ah

* rekommenderat märke

OBS!

Kapaciteten hos laddningsbara batterier avtar om batterierna inte används kontinuerligt eller omladdas med jämna mellanrum. Läs därför noga igenom lagringsföreskrifterna.

4.2. Laddning

Batteriet laddas automatiskt när instrumentet är anslutet till nätet och huvudbrytaren står på OFF.

När displayet visar "LO BAT" finns det kapacitet kvar för 15 minuters drift innan batteriet behöver laddas om.

Vid nätspänningsbortfall kopplar räknaren automatiskt om till batteridrift.

Använd alltid huvudbrytaren för att stänga av instrumentet, inte nätkabeln! På så sätt undviker man att batteriet laddar ur när räknaren inte används.

Laddningstid (typiskt värde vid 20°C) upp till full kapacitet är 10 timmar, upp till 70% kapacitet 5 timmar.

4.3. Lagring

Undvik att lagra helt urladdade batterier.

När instrumentet inte används, ställ huvudbrytaren på OFF men låt instrumentet vara anslutet till nätet. Batteriet är då hela tiden fullt uppladdat och driftklart. Ifall instrumentet ej kan vara anslutet till nätet, eller om batterienheten lagras utanför instrumentet, rekommenderar vi att batteriet laddas om var 3:e månad under 5—10 timmar.

Om batteriet skall lagras under längre tid, ta bort säkringen i batterienheten och förvara batteriet på sval och torr plats.

OBS!

Ständig användning och lagring vid höga temperaturer minskar batteriets livslängd.

Långvarig lagring och drift över +40°C samt laddning vid över +35°C bör undvikas.

Före lagring vid —40°C skall batteriet laddas upp till minst 75% av den fulla kapaciteten.

Övriga omgivningsfaktorer är desamma som för själva räknaren.

Vikt: 0,75 kg.

Säkring: 1,6A snabb.

5. Externt batteri

Räknaren kan även drivas med externt batteri. Byt i så fall BNC-intaget på baksidan mot ett batterijack (se beskrivning i avsnitt 7.5 i detta instruktionshäfte).

ANM

Batterijacket inkl stickpropp kan beställas kostnadsfritt hos:

Philips Elektronikindustrier AB
Div. I Supply Center Service
175 88 JÄRFALLA

V.g. ange instrumentets typnummer och serienummer.

6. Säkerhetsbestämmelser

(enl IEC 348)

Innan ni ansluter instrumentet till nätet: se över instrumenthuset, kontroller, anslutningar osv och kontrollera att inga transportskador finns.

Om skador upptäcks får instrumentet inte anslutas till nätet. Det skall skiljas från samtliga spänningskällor innan några reparations- eller underhållsarbeten företas.

Ändringar eller reparationer som måste utföras när instrumentet är i drift och skyddslocken borttagna, får endast utföras av kunnig fackman som är medveten om riskerna.

OBS!

Samtliga delar på transformatorns primärsida är godkända av CSA och bör endast ersättas med originalreservdelar.

7. Handhavande

7.1. Nätanslutning

Kontrollera först att instrumentet är inställt på den lokala nätspänningen. Inställningen vid leverans (115 V eller 220 V \pm 15%) finns angiven på instrumentets baksida. Om räknaren behöver inställas på en annan spänning än den angivna, kontakta er serviceorganisation.

Dessutom innehåller servicehandboken detaljerade anvisningar.

7.2. Jordning

Instrumentet är skyddsjordat via 3-ledarnät-kabeln som skall anslutas till vägguttag med jorddon.

Ingen annan form av skyddsjordning är tillåten.

7.3. Intern och extern standard

Genom omkoppling av jumpern DV 101 kan räknaren ställas in på antingen extern eller intern standard. (Se fig. nedan.)

Vid leverans är räknaren inställd på intern standard.

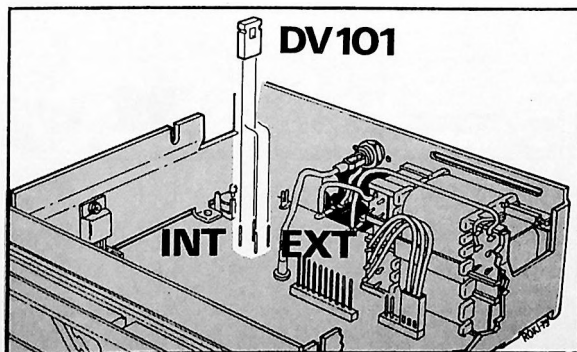

7.4. Montering av intern batterienhet PM 9601

- Ta bort instrumentkåpan.
- Ta bort övre skyddslocket.
- Ta bort +5V-regulatorn IC 112 (se fig. nedan).
- Sätt i batterienheten som på bilden nedan. Placera ledningarna från batteriet till kretskortet utmed batteriets kanter.
- Sätt på det nya skyddslocket som bilden visar och fäst det på instrumentets sidoväggar med 2 skruvar.
- Skruva fast batterienheten på instrumentets sidor.

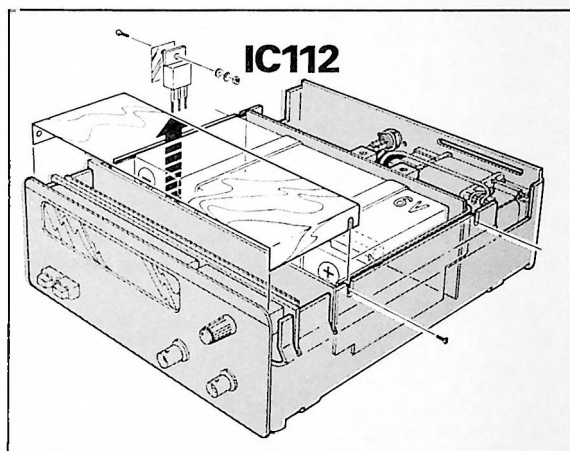

7.5. Jack för externt batteri

Det bakre BNC-intaget för extern standard kan bytas ut mot ett batterijack för anslutning till ett externt batteri. Jacket passar DIN 45323.

Gör så här för att ersätta BNC-intaget med batterijack:

- Lösgör koaxialkabeln från kretskortet och löd loss innerledaren från BNC-kontakten.
- Byt ut BNC-kontakten mot batterijacket och anslut den tvåpoliga kontakten så att den stämmer överens med polariteten på den yttre spänningskällan.

Den 2-poliga kontakten (p/o BU 107) är diodskyddad för att förhindra skada om instrumentet ansluts med fel polaritet.

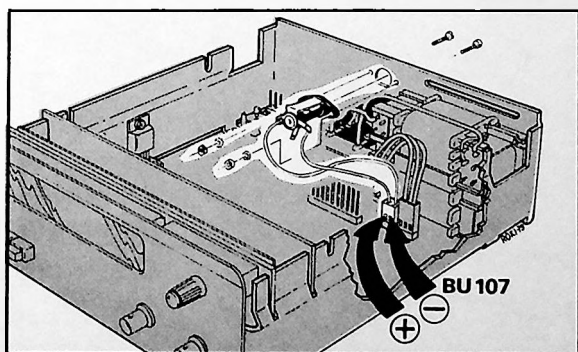

8. Kontroller och ingångar

POWER ON

För till- och fränkoppling. OBS! Detta är en sekundär huvudbrytare. Instrumentet har därför spänningsförande delar även när huvudbrytaren står i fränkopplat läge POWER OFF. För att skilja instrumentet helt från nätet skall nätkabeln dras ur.

Vid nätspänningsbortfall kopplar räknaren automatiskt om till batteridrift.

MEASUREMENT RATE

Inställning på en av två mätastigheter: NORMAL eller FAST (tryckknappen intryckt).

NORMAL innebär ca 1 mätning/s och FAST ca 5 mätningar/s. Mätastigheten med driftsättet FAST minskar vid lägre frekvenser och är ca 1 mätning/s vid 10 Hz.

SENSITIVITY

Inställning av ingångskänsligheten i sex steg mellan 15mV_{eff} och 5 V_{eff}.

ANM. Välj aldrig högre känslighet än nödvändigt för att så mycket som möjligt reducera inverkan av brus och störningar.

HF-ingång (PM 6668)

Lågohmig (50 ohm), AC-kopplad ingång för sinussignaler med frekvenser 70MHz till 1GHz.

Räknarens mikrodator registrerar förekomsten av ev HF-signaler och väljer automatiskt denna ingång om infrekvensen är tillräckligt hög och med tillräcklig impedans. Samma signal kan därför påföras båda ingångarna med hjälp av ett T-stycke. Se fig. nedan.

Räkaren kopplar sedan automatiskt om mellan LF- och HF-ingångarna när frekvensen växlar som t ex vid mätning av frekvenssväp.

Mera information om ingångssignalen finns i avsnitt 2, tekniska specifikationer.

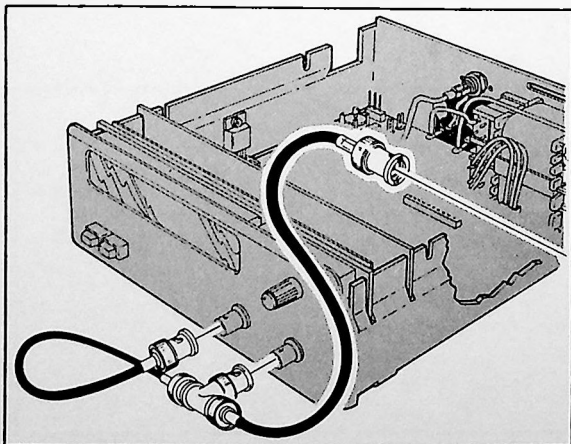

LF-ingång

Höghögig (1 Mohm), AC-kopplad ingång för signaler med frekvenser 10Hz till 120MHz. Ingången har auto-triggkrets som ger korrekt trigging på både sinusvågor och pulser med godtycklig pulskvot.

EXTERN STANDARD eller BATTERI

BNC-ingången för extern tidsbas eller — som extra tillbehör — jack för externt batteri.

Nätanslutning

Nätspänningsingång. Använd alltid 3-ledarnätkabeln som levereras tillsammans med instrumentet.

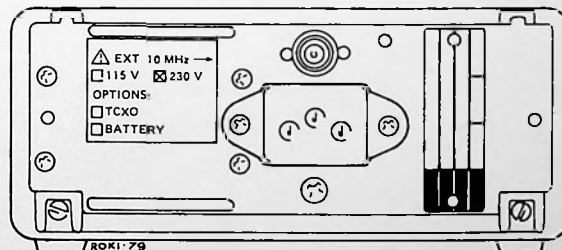
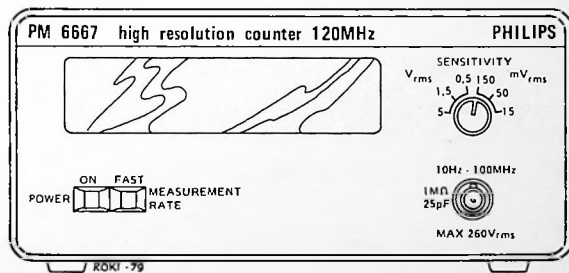
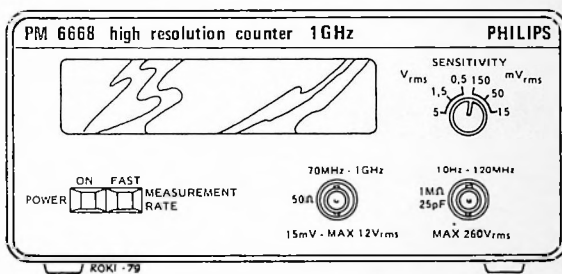



PHILIPS

Istruzioni per l'uso

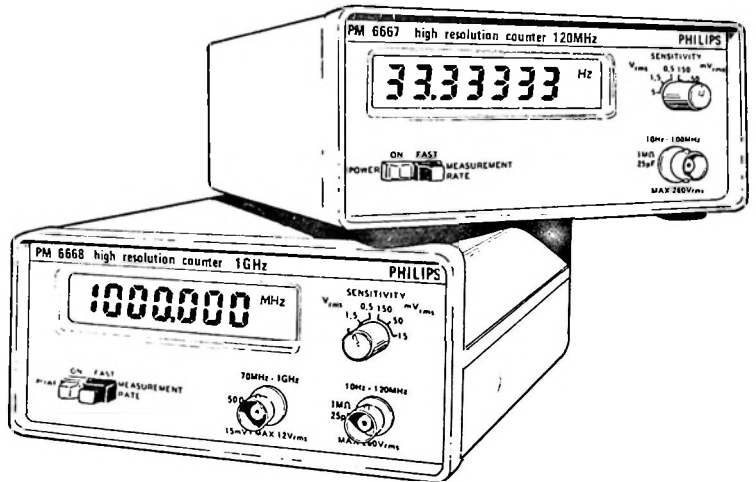

1. Introduzione

I PM 6667 e PM 6668 sono due contatori di frequenza basati su microprocessore, per misure di frequenza da 10 Hz ... a 120 MHz (PM 6667) e da 10 Hz ... 1 GHz (PM 6668).

L'impiego del microprocessore consente un nuovo sistema nelle misure di frequenze che elimina il tradizionale errore di ± 1 ciclo. Eseguendo la misura di un multiplo del periodo e calcolandone il valore reciproco, questi contatori realizzano misure di frequenze con elevatissima risoluzione su segnali di bassa frequenza.

Altra prerogativa di questi contatori è la selezione automatica della gamma e che il risultato quindi viene sempre rappresentato automaticamente, con la massima risoluzione possibile senza fuori-scala e con la relativa indicazione di Hz, kHz, MHz e punto decimale.

Si può scegliere tra due cadenze di misura: NORMAL, una al secondo con risoluzione sempre di 7 cifre oppure FAST, cinque al secondo, con risoluzione di 6 o 7 cifre; questo mo-

do viene usato per misurare frequenze che cambiano, per esempio in fase di tarature.

Sono disponibili le seguenti opzioni: una versione con base tempi più stabile con TCXO (versione/02), un'unità PM 9601 con batteria ricaricabile montabile entro il contatore, una valigetta PM 9602 in materiale antiurto (ABS) ed un adattatore PM 9603 per montaggio su rack 19".

L'indicatore a 7 cifre a cristalli liquidi (LCD) è completo di unità di misura e punto decimale. Ogni volta che si accende il contatore viene eseguita una routine di prova e, se vi fosse un guasto, apparirà sul display un'indicazione secondo un codice diagnostico.

ATTENZIONE

Prima di collegare lo strumento alla rete, leggere le norme di sicurezza a pag. 29.

2. Specifica tecnica

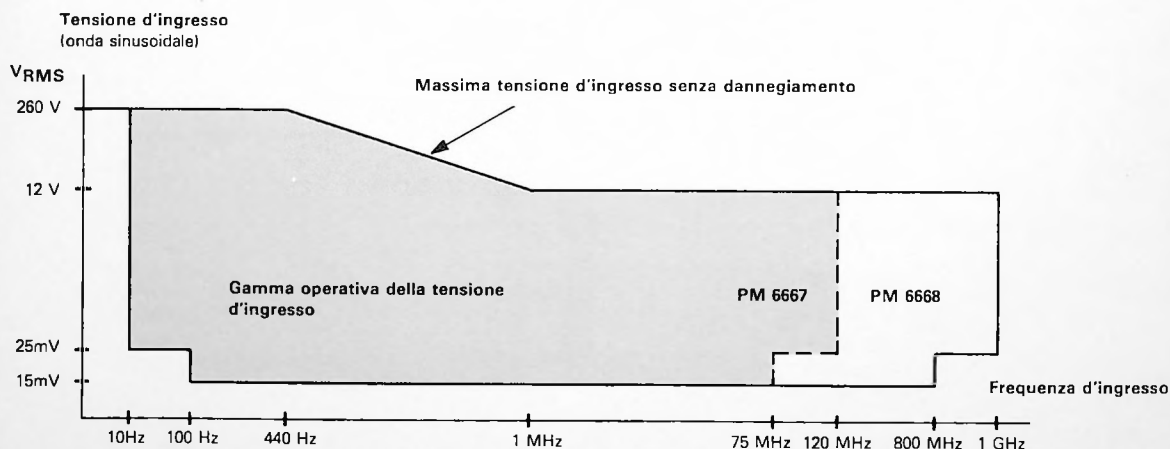

Gamma di frequenza

PM 6667: 10Hz ... 120MHz
PM 6668: 10Hz ... 1GHz

Sensibilità d'ingresso

(posizione 15mV_{eff})

Ingresso BF: 15mV_{eff} sinusoidale;
100Hz ... 75MHz

25mV_{eff} sinusoidale;
10Hz ... 120MHz

45mV_{p-p} per impulsi
con una durata ≥ 7 ns

Ingresso RF: (solo PM 6668)

15mV_{eff} sinusoidale;
70MHz ... 800MHz

25mV_{eff} sinusoidale;
800MHz ... 1GHz

(vedere caratteristiche di tensione
d'ingresso)

Attenuazione d'ingresso

Ingresso BF: x 1 a x 300 in 6 posi-
zioni

Ingresso RF: attenuazione automatica

Livello di trigger

Una tensione fissa (+, 0 o -) viene applicata automaticamente in modo di assicurare un trigger adeguato per ogni forma d'onda e per ogni rapporto ciclico.

Accoppiamento: AC

Impedenza d'ingresso

Ingresso BF: $1M\Omega // \approx 25pF$

Ingresso RF: 50 Ω nominale con
VSWR < 2
(solo PM 6668)

Risoluzione ed errore di trigger

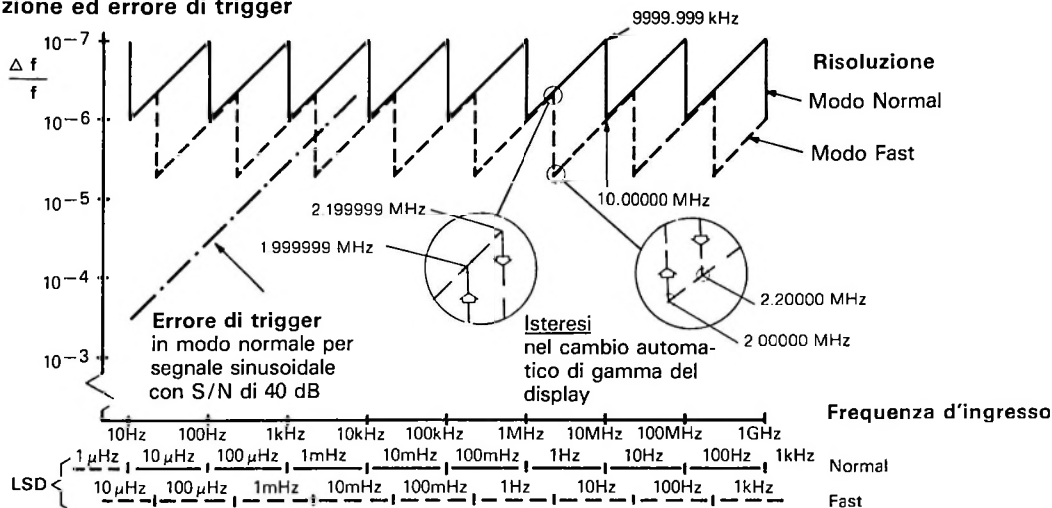

Tensione massima d'ingresso senza danno

DC: 300V

AC: $260V_{\text{eff}}$ a $f \leq 440\text{Hz}$ scendendo a $12V_{\text{eff}}$ a 1 MHz (vedi caratteristiche di tensione di ingresso alla pagina precedente).

Cadenza di misura

Normal: (out) ca. 1 misura/sec.

Fast: (in) ca. 5 misure/sec.*

* con frequenze inferiori ai 100 Hz la cadenza di misura rallenta gradualmente fino ad una misura per secondo in modo da ridurre l'influenza dell'errore di trigger.

Display

7 cifre, 11,5 mm; display a cristalli liquidi con indicazione unità Hz, kHz, MHz e LO BAT.

Imprecisione (errore relativo di frequenza)

$\pm \frac{\text{LSD}}{\text{Frequenza d'ingresso}} \pm \text{errore relativo di trigger}^{**}$

\pm Errore base dei tempi

** Errore relativo di trigger:

Per ogni forma d'onda:

Misure per secondo
 Pendenza segnale (V/s) \times tensione rumore
 piccolo piccolo.

Per onde sinusoidali:

Misure per secondo
 Frequenza ingresso $\times \pi \times$ S/N

Esempio: per un rapp. S/N di 100 (40dB) ed una cadenza di misura di una misura/sec.

L'errore di trigger è:

$$3 \times 10^{-3}$$

frequenza d'ingresso

Risoluzione

Per la cifra meno significativa (LSD) e relativa risoluzione, vedi grafico qui sopra.

Ingresso standard esterno

Frequenza: 10MHz
 Tensione: $0,5V_{\text{eff}} \dots 12V_{\text{eff}}$
 Impedenza d'ingresso: ca. 2k Ω

Alimentazione richiesta

115/230V, $\pm 15\%$, 50 ... 60Hz; 15VA oppure da alimentatore a batteria ricaricabile incorporato (PM 9601 opzionale) oppure una alimentazione esterna di 12 V c.c.

Sicurezza

Secondo IEC 348 e CSA 556B.

Interferenze linea

Nei limiti di classe II CENELEC/CISPR

Caratteristiche base di tempo

Versione base di tempo	/01 (standard)	/02 (TCXO)
Frequenza	10MHz	10MHz
Invecchiamento	$\leq 5 \times 10^{-7}$ /mese	$\leq 1 \times 10^{-7}$ /mese
Stabilità temperatura		
0 ... 50°C relativo a 25°C	$\leq 1 \times 10^{-5}$	$\leq 1 \times 10^{-6}$
20 ... 30°C relativo a 25°C	$\leq 3 \times 10^{-6}$ (tipico)	$\leq 3 \times 10^{-7}$ (tipico)

Ingombro e peso

Larghezza: 160 mm (6,3")

Altezza: 77 mm (3")

Profondità: 180 mm (7,1")

Peso: 1,2 Kg (2,6lb.)

Condizioni ambientali

Temperatura:

Immagazzinaggio: $-40^{\circ}\text{C} \dots +70^{\circ}\text{C}$

Funzionamento: $0^{\circ}\text{C} \dots +45^{\circ}\text{C}$

Altitudine/pressione barometrica:

Immagazzinaggio: 15000 m/(50000 ft)

/15,2kN/m²

Funzionamento: 5000 m/(15000 ft)

/53,3kN/m²

Umidità:

10% ... 90% RH
 (punto di rugiada 26°C)

Prova

vibrazione: secondo IEC 68 Fc
 Prova urto: secondo IEC 68 Eb

Prova

maneggevolezza: secondo IEC 68 Ec
 Prova trasporto: secondo NLN - L88

3. Accessori

3.1. Accessori standard (consegnati con lo strumento)

- Cavo alimentazione rete.
- Manuale con istruzioni.

3.2. Accessori a richiesta (da ordinare separatamente)

- Alimentatore a batterie PM 9601.
- Valigetta per trasporto PM 9602.
- Pannello adattatore per montaggio a rack 19" PM 9603.
- Filtro passa basso 50 kHz, BNC-BNC, PM 9665B.
- Sonda attenuata 10 Mohm, 15 MHz, PM 9236.
- Sonda attenuata 10 Mohm, 250 MHz, PM 8935.
- Presa a jack (vedi sezione 5 e 7.5 di questo manuale).

4. Alimentatore a batterie ricaricabili PM 9601

4.1. Informazioni Generali

Il PM 9601 è un alimentatore a batterie ricaricabili per montaggio all'interno dei contatori PM 6667 e PM 6668.

L'unità contiene una batteria a 6 V ermetica a "Solid gel" (vedi tabella) ed il relativo circuito per la ricarica controllata e protetta.

L'unità viene fissata con quattro viti nel contenitore metallico interno (vedi istruzioni di montaggio).

La batteria è di tipo standard ed è reperibile presso numerosi fabbricanti di batterie. Per ottenere batterie di ricambio contattare direttamente il Vs. abituale fornitore che ha normalmente batterie fresche e cariche:

Fabbricante	Nazione di origine	Tipo	Capacità
Sonnenschein*	Germania		
	Fed.	3GX3S	3 Ah
Varta*	Germania		
	Fed.	Accu Pb30704063	3 Ah
Gold Gelyte	Stati Uniti	Pb 626-1	2.6 Ah
Elpower	Stati Uniti	Ep 626A-6	2.6 Ah
SAFT*	Francia	PA 601	4 Ah
Kono	Giappone	6-26K	2.6 Ah

* raccomandata

ATTENZIONE

La capacità delle batterie ricaricabili degrada qualora non vengano usate e ricaricate frequentemente. Leggere quindi attentamente le istruzioni per la tenuta a magazzino.

4.2. Ricarica

La batteria si ricarica automaticamente quando il contatore è collegato alla rete e l'interruttore di accensione è su "OFF".

Dal momento in cui appare sul display la scritta "LO BAT" si hanno ancora 15 minuti di funzionamento prima della necessità di ricarica.

Il contatore commuta automaticamente la propria alimentazione sulla batteria interna qualora manchi tensione dalla rete.

Per evitare che le batterie si scarichino quando il contatore non viene utilizzato, usare sempre l'interruttore per spegnere il contatore e non la spina di rete.

Tempo di ricarica (tipico a 20°C): 10 ore al 90% della piena capacità, 5 ore al 70%.

4.3. Immagazzinaggio

Evitare l'immagazzinaggio di batterie totalmente scaricate. Quando il contatore non viene utilizzato, commutare in posizione "OFF" ma mantenere lo strumento collegato alla rete. La batteria rimarrà allora caricata e sempre pronta all'uso. Se l'apparecchio non può essere collegato alla rete o se l'alimentatore a batterie è immagazzinato al di fuori dello strumento, si raccomanda di ricaricarlo per 5 o 10 ore ogni 3 mesi.

Se le batterie devono essere tenute a magazzino per lunghi periodi, togliere il fusibile e immagazzinare l'alimentatore in luogo fresco e secco.

ATTENZIONE

Lunghi periodi di immagazzinaggio o di uso a temperature elevate compromettono la durata della batteria.

L'immagazzinaggio prolungato e il funzionamento a temperature superiori ai 40°C così come la carica a temperature superiori ai 35°C dovrebbero essere evitati.

In caso di immagazzinaggio a temperature inferiori ai -40°C, la batteria deve essere caricata almeno al 75% della piena capacità. Le altre condizioni ambientali sono uguali a quelle valide per lo strumento.

Peso addizionale per l'alimentatore a batterie: 0,75 Kg.

Fusibile: 1,6A ad azione rapida.

5. Batteria esterna

Una batteria esterna a 12 V può essere utilizzata come alimentazione per il contatore. Sostituisce nel retro dello strumento il connettore BNC con un innesto a jack per batterie come illustrato alla sezione 7.5 di questo manuale.

NOTA

Il jack per batteria e relativa spina può essere ordinata gratuitamente alla:

Philips Elektronikindustrier AB
Div. I Supply Center Service
S-175 88 JÄRFALLA
SVEZIA

Vogliate indicare il numero di tipo e serie dello strumento in causa.

6. Norme di sicurezza

(Secondo IEC 348)

Prima di collegare lo strumento alla rete, verificare visualmente i comandi, connettori ecc. per accertarsi dell'assenza di qualunque danno che avrebbe potuto prodursi durante il trasporto.

Se si riscontrassero difetti evidenti, non collegare lo strumento alla rete.

Prima di qualunque manutenzione o riparazione lo strumento deve essere scollegato da ogni fonte di tensione ed ogni punto ad alta tensione deve essere scaricato.

Regolazioni e manutenzioni dello strumento in funzionamento con il coperchio rimosso, possono essere eseguite soltanto da tecnici specializzati che conoscano i pericoli che esistono.

NOTA

Tutte le componenti che si trovano al primario del trasformatore sono a norme CSA ed all'occorrenza devono essere usati soltanto ricambi originali.

7. Installazione

7.1. Collegamento rete

Prima di collegare lo strumento alla rete, assicurarsi che sia predisposto per la tensione di rete locale. Alla consegna, l'apparecchio è predisposto per 115V o 230V \pm 15%, secondo quanto indicato sul retro dello strumento. Se occorre cambiare la tensione, rivolgersi all'organizzazione di Servizio locale. Il Manuale di Servizio contiene le istruzioni per il cambio di tensione.

7.2. Messa a terra

L'apparecchio è messo a terra attraverso il cordone di alimentazione a tre conduttori inserito in una presa con contatto di terra protetto. Non viene autorizzato nessun altro modo di messa a terra.

7.3. Standard interno ed esterno

Il contatore può essere impostato sullo standard interno ed esterno inserendo il connettore DV 101 come indica la figura in basso.

All'atto della consegna, il contatore è impostato per lo standard interno.

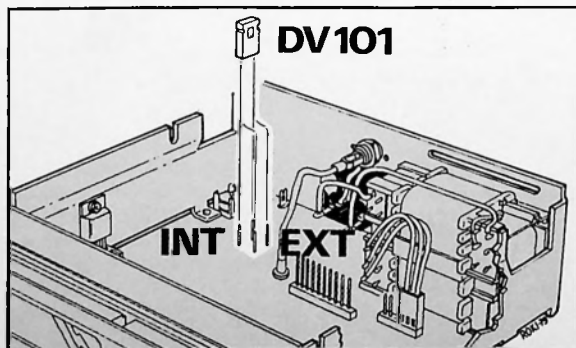

7.4. Alimentatore a batteria PM 9601

- Togliere il cofano del contatore.
- Togliere la piastra superiore di schermaggio.
- Levare il regolatore 5V IC 112 (vedi fig. qui sotto).
- Inserire l'alimentatore a batteria come qui sotto. Tenere i fili dalla batteria alla piastra stampata lungo i lati della batteria.
- Montare la nuova piastra di schermaggio come da fig. qui sotto e fissarla ai lati del contatore per mezzo di due viti.
- Fissare l'alimentatore per mezzo delle viti ai lati del contatore.

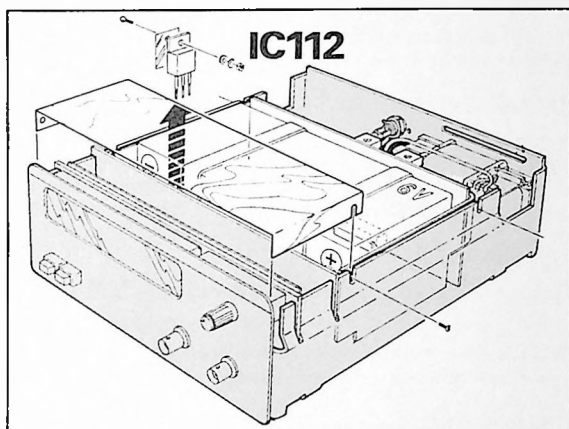

7.5. Jack per batteria esterna

Il contatore BNC sul retro, che serve per lo standard esterno potrà essere sostituito da una presa a jack per alimentazione da batteria esterna.

Procedere come segue per la sostituzione del BNC con il jack per batteria:

- staccare il cavo coassiale dalla piastra stampata e dissaldare il conduttore centrale del BNC.
- sostituire il BNC con il jack per batteria e collegare il conduttore in modo che coincida con la polarità della presa batteria.

Vedi qui sotto.

La spina doppia (BU 107) è protetta con diodi per evitare danni in caso di inversione della polarità di batteria.

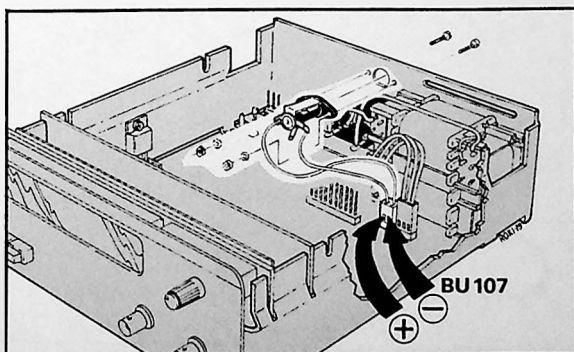

8. Comandi e connettori

POWER ON

Serve per accendere o spegnere lo strumento. ATTENZIONE si tratta di un commutatore sul secondario, e quindi anche in posizione "POWER OFF" all'interno dello strumento vi sono punti sotto tensione e componenti cariche. Per togliere completamente tensione si deve staccare il cavo di alimentazione dalla rete.

In caso di mancanza di tensione di rete, il contatore è automaticamente commutato su alimentazione da batteria.

MEASUREMENT RATE

Serve per variare la cadenza della misura: NORMAL oppure FAST. In NORMAL si esegue 1 misura al secondo, in FAST 5 misure al secondo, ridotte automaticamente per frequenze molto basse sino ad 1 misura al secondo per 10 Hz.

SENSITIVITY

Regola in 6 passi la sensibilità d'ingresso da $15mV_{eff}$ a $5V_{eff}$.

NOTA: Per ridurre l'influenza di disturbi e interferenze non posizionare mai su sensibilità superiori a quella necessaria.

Ingresso RF solo sul PM 6668

Ingresso accoppiato in AC a bassa impedenza (50 ohm) per segnali a frequenze da 70 MHz a 1 GHz.

Il microprocessore del contatore rivela la presenza di un segnale RF e sceglie automaticamente questo ingresso appena che la frequenza di entrata è sufficientemente alta per la misura. Questo rende possibile il collegamento simultaneo, mediante un raccordo a T, dello stesso segnale alle due entrate. (Vedi figura qui sotto.) Il contatore commuterà automaticamente sull'uno o sull'altro dei due ingressi nel momento in cui la frequenza di un segnale cambia; per esempio nel caso di una frequenza spazzolata.

Più informazioni sul segnale in ingresso sono date nella sezione 2, Specifica Tecnica.

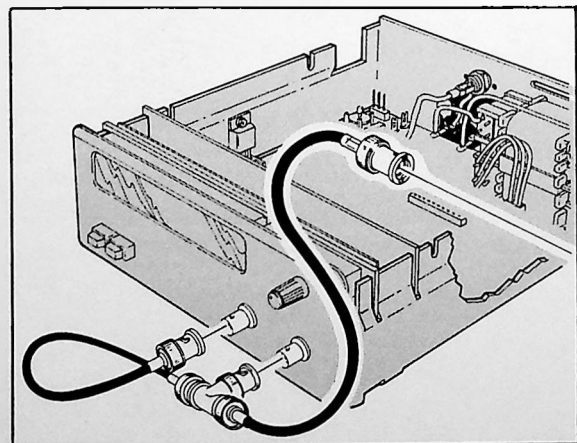

Ingresso Bassa Frequenza

Ingresso accoppiato in AC ad alta impedenza (1 Mohm) per segnali a frequenze da 10 Hz a 120 MHz. Un circuito auto-trigger automaticamente assicura un triggering corretto per ogni tipo di segnale sia impulsivo sia sinusoidale con qualsiasi ciclo di carico.

STANDARD ESTERNO O BATTERIA

Ingresso BNC per lo standard esterno o a scelta, come accessorio opzionale, presa a jack per batteria esterna.

Presenza tensione rete

Utilizzare sempre il cordone a tre conduttori che viene fornito con il contatore.

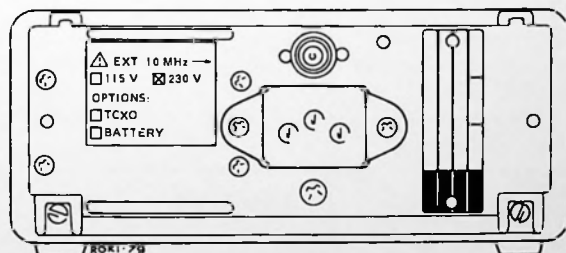
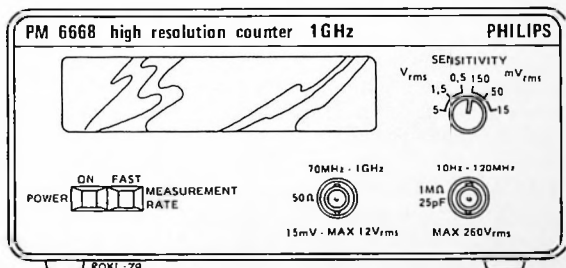
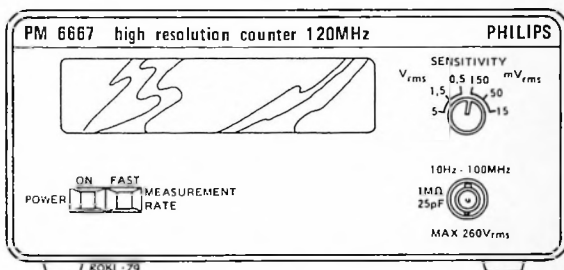



PHILIPS

Gebruiksaanwijzing

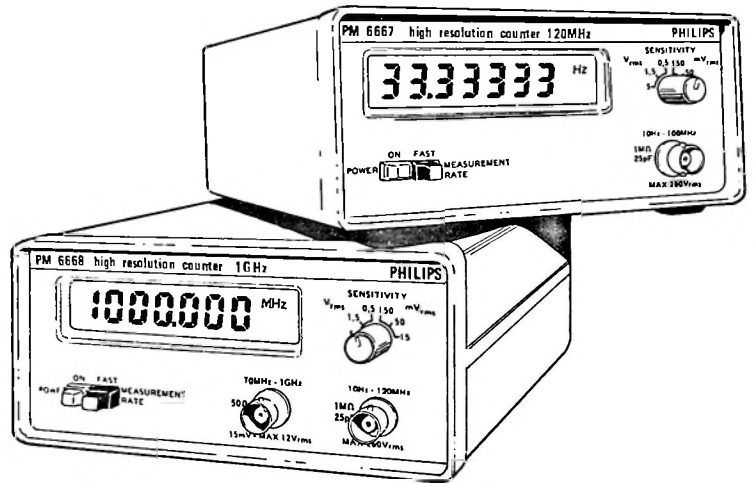

1. Inleiding

De PM 6667 en de PM 6668 zijn frequentiemeters die uitgerust zijn met een microcomputer en een meetbereik hebben van 10 Hz ... 120 MHz (PM 6667) en 10 Hz ... 1 GHz (PM 6668).

De toepassing van de microcomputer maakt een nieuwe aanpak van frequentiemetingen mogelijk waarbij de traditionele fout van ± 1 periode wordt vermeden. Door het uitvoeren van een meervoudige periode meting en het berekenen van de reciproke waarde daar van, kunnen met deze teller lage frequenties worden gemeten met zeer grote resolutie. Een ander voordeel van de microcomputer in deze tellers is de automatische keuze van het meetgebied.

Het meetresultaat wordt altijd weergegeven met maximale resolutie zonder overschrijding van het meetbereik en met de juiste aanduiding van Hz, kHz, MHz en komma.

Men kan kiezen tussen twee meetsnelheden: NORMAL d.w.z. 7 cijfers per seconde of FAST d.w.z. 6 of 7 cijfers per 200 ms. De snelle manier wordt toegepast voor het meten

van wisselende frequenties, zoals bij het afregelen van circuits.

Verder zijn nog de volgende opties beschikbaar: een model met stabilere tijdsbasis TCXO (/02 versie) met oplaadbare accu PM 9601, die aan de binnenkant van de teller kan worden aangebracht, een stootvast (ABS) draagkoffertje PM 9602 en een adaptor PM 9603 voor montage in een 19" rack of paneel.

De 7-cijferige vloeibare kristallen display (LCD) bevat eveneens indicators voor eenheden en komma.

Nadat de teller is ingeschakeld, voert deze zelf een controle uit. Ingeval er ergens een fout is ontdekt, wordt deze door een diagnostische code aangeduid.

WAARSCHUWING:

Voor dat de teller op de netspanning wordt aangesloten, dient men eerst de veiligheidsvoorschriften op bladzijde 35 te lezen.

2. Technische specificaties

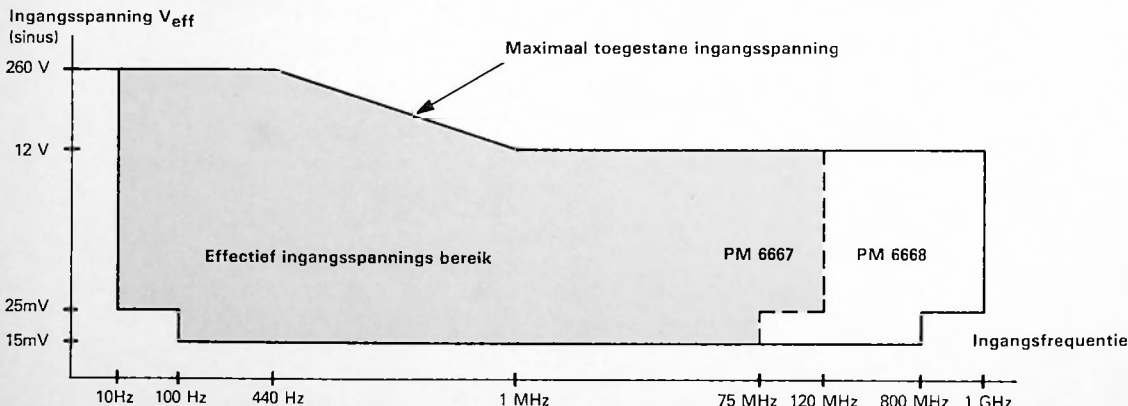

Frequentiebereik

PM 6667: 10Hz ... 120MHz
PM 6668: 10Hz ... 1GHz

RF-ingang: (alleen PM 6668)

15mV_{eff} sinus;
70MHz ... 800MHz

25mV_{eff} sinus;
800MHz ... 1GHz

(zie ingangsspannings diagram)

Maximaal toegestane ingangsspanning (zonder beschadiging)

Gelijkspanning: 300V
Wisselspanning: 260V_{eff} bij ≤ 440 Hz, afnemend tot 12V_{eff} bij 1 MHz (zie bovenstaande eigenschappen betr. ingangsspanning)

Ingangsgevoeligheid (in 15mV_{eff} positie)

LF-ingang: 15mV_{eff} sinus;
100Hz ... 75MHz

25mV_{eff} sinus;
10Hz ... 120MHz

45mV_{p-p} voor impulsen met een impulsduur van ≥ 7 ns

Ingangsdemping

LF-ingang: x 1 tot x 300 in 6 standen
RF-ingang: automatische demping

Trigger niveau

Een vaste spanning (+, 0 of -) wordt automatisch toegevoerd voor het juiste triggeren op elke signaalvorm en werkcyclus.

Koppeling: wisselspannings gekoppeld.

Ingangsimpedantie

LF-ingang: 1M Ω // ≈ 25 pF
RF-ingang: 50 Ω nominaal met staande golf verhouding < 2 (alleen voor de PM 6668)

Oplossend vermogen en trigger fout

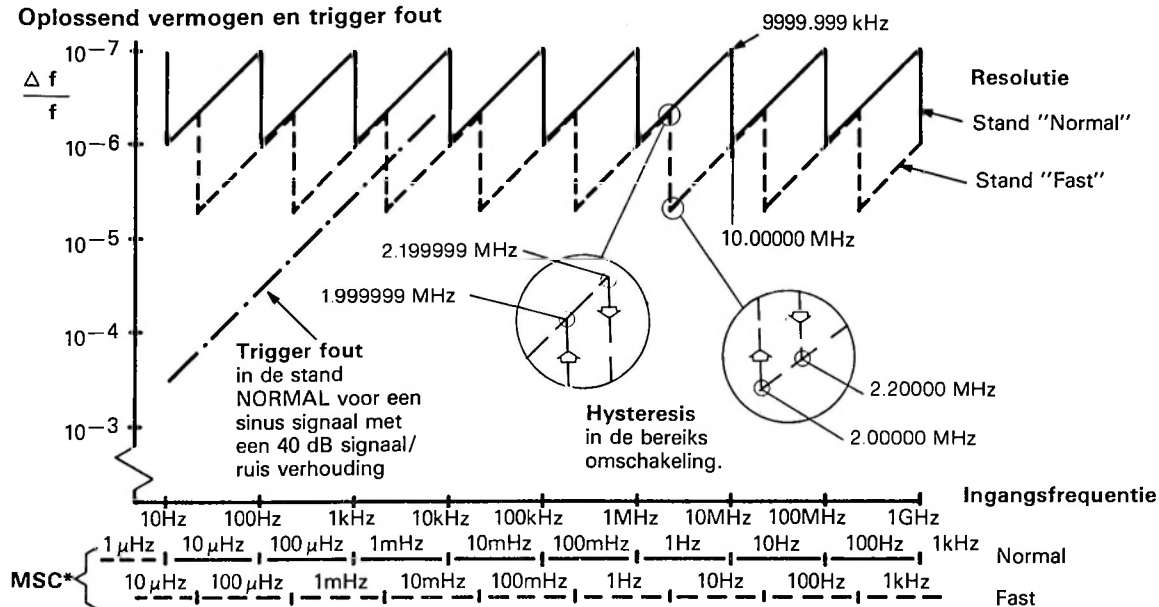

Meetsnelheid

Normal (Normaal), (uit): ongeveer 1 meting/seconde

Fast (Snel), (in): ongeveer 5 metingen/seconde. Bij frequenties onder 100 Hz, neemt de meetsnelheid geleidelijk af tot één meting per seconde om de invloed van de trigger fout te beperken.

Display

7 cijfers, 11,5 mm, vloeibare kristallen display met aanduiding Hz, kHz, MHz en LO BAT (lege accu).

Onnauwkeurigheid (relatieve frequentie fout)

$$\pm \frac{\text{MSC}^*}{\text{ingangsfrequentie}} \pm \text{Rel. trigger fout}$$

$$\pm \text{tijdbasis fout}$$

Rel. trigger fout:

Voor iedere signaalvorm:

$$\frac{\text{meetsnelheid}}{\text{helling v.h. signaal (V/s)}} \times \text{piek tot piek ruisspanning}$$

Voor sinus signalen

$$\frac{\text{meetsnelheid}}{\text{ingangsfrequentie} \times \pi \times \text{signaal/ruis verhouding}}$$

* minst significante cijfer.

Voorbeeld: Bij een signaal/ruis verhouding van 100 (40dB) en een gekozen snelheid van 1 meting/sec. draagt de triggerfout:

$$\frac{3 \times 10^{-3}}{\text{ingangsfrequentie}}$$

Oplossend vermogen

Wat het minst significante cijfer (MSC) en het oplossend vermogen betreft, zie bovenstaande grafiek.

Externe referentie ingang

Frequentie: 10 MHz
Ingangsspanning bereik: 0,5V_{eff}...12V_{eff}
Ingangsimpedantie: ongeveer 2kΩ

Voedings spanning

115/230V, ±15%, 50 ... 60Hz; 15VA of de ingebouwde accu (accessoire) PM 9601 of een externe 12 V gelijkspanning.

Veiligheid

Overeenkomstig IEC 348 en CSA 566 B.

Tijdbasis eigenschappen

Tijdbasis versii	/01 (standaard)	/02 (TCXO)
X-tal frequentie	10MHz	10MHz
Oudering	≤ 5 × 10 ⁻⁷ /maand	≤ 1 × 10 ⁻⁷ /maand
Temperatuurbestendigheid	0...50°C, cal, temp +25°C	≤ 1 × 10 ⁻⁶
20...30°C, cal, temp +25°C	≤ 3 × 10 ⁻⁶ (typisch)	≤ 3 × 10 ⁻⁷ (typisch)

Netstoring

Lager dan klasse II CENELEC/CISPR.

Afmetingen en gewicht

Breedte: 160 mm
Hoogte: 77 mm
Lengte: 180 mm
Gewicht: 1,2 kg

Omgevingscondities

Temperatuur:

Opslag: -40°C ... +70°C
Werking: 0°C ... +45°C

Hoogte/barometer druk:

Opslag: 15000 m/15,2 kN/m²
Werking: 5000 m/53,3 kN/m²

Vochtigheid:

10% ... 90% relatieve vochtigheid (dauwpunt 26°C)

Trillingsproef: voldoet aan IEC 68 Fc

Stootproef: voldoet aan IEC 68 Eb

Hanteringsproef: voldoet aan IEC 68 Ec

Transportproef: voldoet aan NLN-L88

3. Accessoires

3.1. Standaard accessoires (meegeleverd met het apparaat)

- Netsnoer
- Instructiehandboek

3.2. Opties

(afzonderlijk te bestellen)

- PM 9601 oplaadbare accu-eenheid
- PM 9602 draagkoffertje
- PM 9603 hulpstuk voor montage in 19" rek of paneel
- PM 9665 B 50 kHz laagdoorlaat filter, BNC—BNC
- PM 9236 15 MHz, 10 Mohm verzwakkersonde
- PM 8935 250 MHz, 10 Mohm verzwakkersonde
- Batterijsteker (zie par. 5 en 7.5 in dit handboek).

4. Accu-eenheid PM 9601

4.1. Algemene gegevens

De PM 9601 is een oplaadbare accu, die in de tellers PM 6667 en PM 6668 gemonteerd kan worden. De eenheid bevat een gasdichte 6 V batterij van het lood-zuurgelei type. Verder bevat deze het laadcircuit alsmede een beveiliging tegen overbelasting.

De accu-eenheid wordt met vier schroeven in het metalen binnenframe van de kast gemonteerd (zie installatievoorschriften).

Het is een standaard accu, die bij diverse accufabrikanten verkrijgbaar is. Voor reserveaccu's neemt U rechtstreeks contact op met Uw acculeverancier, die nieuwe opgeladen accu's in voorraad heeft.

Fabrikant	Land van herkomst	Type	Capaciteit
Sonnenschein*	West Duits-land	3GX3S	3 Ah
Varta*	West Duits-land	Accu Pb 30704063	3 Ah
Gold Gelyte	Verenigde Staten	Pb 626-1	2.6 Ah
Elpower	Verenigde Staten	Ep 626A-6	2.6 Ah
SAFT*	Frankrijk	PA 601	4 Ah
Kono	Japan	6-26k	2.6 Ah

* aanbevolen merk

WAARSCHUWING

De capaciteit van oplaadbare accu's neemt af als de accu's niet worden gebruikt of niet herhaaldelijk worden opgeladen. Lees daarom nauwkeurig de aanwijzingen voor opslag.

4.2. Opladen

De accu wordt automatisch opgeladen zodra de teller op de netspanning wordt aangesloten, en de schakelaar in de OFF-stand staat.

Als 'LO BAT' oplicht, dan werkt de accu nog ongeveer 15 minuten voordat deze opnieuw moet worden opgeladen.

De teller schakelt automatisch over op de interne accu-voeding als de netspanning uitvalt.

Om ongewenste ontlading van de batterijen te voorkomen als de teller niet wordt gebruikt, moet men altijd de aan/uit schakelaar (en niet het netsnoer) gebruiken om de teller uit te schakelen.

De oplaadtijd bedraagt bij 20°C: 10 uur tot 90% van de volledige capaciteit, 5 uur tot 70% van de volledige capaciteit.

4.3. Opslag

Vermijd de opslag van lege accu's.

Als het apparaat niet in gebruik is zet dan de schakelaar in de OFF-stand, maar houd het wel op de netspanning aangesloten. De batterij blijft dan opgeladen en is altijd klaar voor gebruik. Als het apparaat niet op de netspanning kan worden aangesloten of als de batterijen buiten het apparaat zijn opgeslagen, dan is het aan te bevelen om de batterijen om de drie maanden gedurende 5 tot 10 uren op te laden.

Als het apparaat langer opgeslagen moet blijven, verwijder dan de zekering uit de batterijhouder en bewaar de batterij koel en droog.

WAARSCHUWING

Permanent gebruik en opslag bij hoge temperatuur heeft een negatieve invloed op de levensduur van de accu.

Langdurige opslag en gebruik boven +40°C alsmede opladen boven +35°C moet vermeden worden. Voor opslag bij -40°C moet de accu tot minstens 75% van de totale capaciteit worden opgeladen.

De overige omgevingsvoorwaarden zijn dezelfde als voor de teller.

Bijkomend gewicht voor batterijeenheid: 0,75 kg.

Zekering: 1,6 A snel.

5. Externe Batterij

Een externe 12 V batterij kan men gebruiken als krachtbron voor de teller. Vervang de BNC-aansluiting aan de achterkant door een batterijbus, zoals beschreven in par. 7.5. van dit handboek.

OPMERKING

De batterijbus met plug is kosteloos verkrijgbaar bij:

Philips Elektronikindustri AB
Div. I. Supply Center
S-175 88 Järfälla Sweden

Geef daarbij het typenummer en het volgnummer van uw apparaat aan.

6. Veiligheidsvoorschriften

(in overeenstemming met IEC 348)

Voordat men het apparaat op de netspanning aansluit, moet men de kast, regelorganen, aansluitingen, enz. controleren, om er zeker van te zijn dat zich tijdens vervoer geen beschadigingen hebben voorgedaan. Als blijkt dat er gebreken zijn, sluit het apparaat dan niet op het net aan. Het apparaat moet van alle spanningsbronnen losgekoppeld worden, voordat reparatie- of onderhoudswerkzaamheden worden uitgevoerd.

Reparaties of onderhoudswerkzaamheden te verrichten terwijl het apparaat in werking is en de kappen eraf zijn, mogen alleen verricht worden door ervaren personen die zich bewust zijn van de daaraan verbonden gevaren.

OPMERKING

Alle onderdelen aan de primaire zijde van de transformator zijn CSA goedgekeurd en mogen slechts door originele onderdelen vervangen worden.

7. Installatie

7.1. Aansluiting op het net

Voordat men het apparaat op het net aansluit, moet men controleren of het op de juiste plaatselijke netspanning is ingesteld. Bij aflevering wordt het apparaat afhankelijk van bestemming op 115V of 230V $\pm 15\%$ afgesteld, hetgeen achter op het apparaat staat aangegeven. Als het apparaat op een andere spanning moet worden afgesteld dan staat aangegeven, moet U contact opnemen met Uw plaatselijke serviceorganisatie. In het servicehandboek staan de afstelvoorschriften.

7.2. Aarding

Het apparaat wordt geaard via het drieadrig netspanningsnoer dat in een geaard stopcontact wordt gestoken.

Een andere manier van aarden is niet toegestaan.

7.3. Interne en externe tijdstandaard

De teller kan men instellen op externe of interne standaard door brugverbinding DV 101 aan te brengen als aangegeven in de onderstaande figuur.

Bij aflevering wordt de teller op de interne standaard afgesteld.

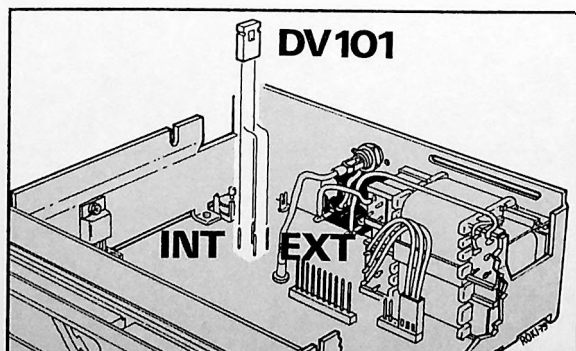

7.4. Interne batterijeenheid PM 9601

- Verwijder het tellerhuis.
- Verwijder de bovenste afschermplaat.
- Verwijder de +5V regelaar IC 112 (zie onderstaande figuur).
- Plaats batterijeenheid zoals aangegeven in onderstaande figuur. Leg de draden van de batterij naar de printplaat langs de zijkanten van de batterij.
- Bevestig de nieuwe afschermplaat zoals aangegeven in onderstaande figuur, en zet deze met twee schroeven aan de zijwanden van de teller vast.
- Schroef de houder tegen de zijwanden van de teller.

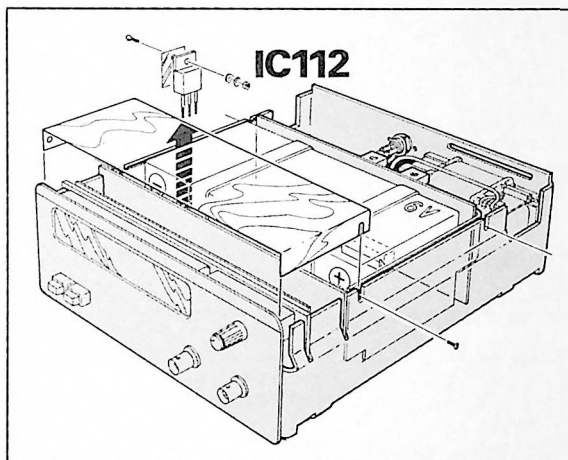

7.5. Externe stekkerbus voor batterij

De BNC-bus aan de achterkant van de externe standaard kan men vervangen door een bus voor externe batterijvoeding. De bus komt overeen met DIN 45323.

Ga bij het vervangen van de BNC-bus door de bus voor batterijvoeding als volgt te werk:

- Maak de coaxkabel los van de printplaat en soldeer de centrale verbinding van de BNC-bus los.
- Vervang de BNC-bus door de batterijbus en sluit de tweepolige bus zodanig aan dat deze overeenkomt met de polariteit van Uw batterijplug. Zie onderstaande figuur.

De tweepensaansluiting (p/o BU 107) wordt met een diode beschermd om schade te voorkomen als de inganspolariteit wordt verwisseld.

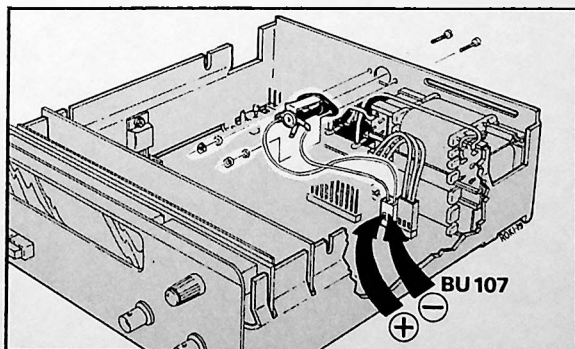

8. Regelingen en aansluitingen

Inschakelen

Schakel de teller in/uit. **VOORZICHTIG:** Dit is een secundaire schakelaar. Zelfs in de POWER-OFF stand, bevat de teller spanning voerende delen. Het netsnoer moet verwijderd worden om de teller volledig uit te schakelen.

Als de netspanning uitvalt, schakelt de teller automatisch op batterijvoeding over.

Meetsnelheid

Stel de meetsnelheid in op een van de twee snelheden. **NORMAL** (niet ingedrukt) of **FAST** (ingedrukt).

NORMAL (normaal) houdt in: ongeveer één meting per seconde en **FAST** (snel) ongeveer 5 metingen per seconde. De meetsnelheid in de snelstand wordt bij lagere frequenties tot ongeveer één meting per seconde bij 10 Hz teruggebracht.

Gevoeligheid

Stel de ingangsgevoeligheid in met keuze uit zes bereiken van 15 mV_{eff} tot 5 V_{eff}.

N.B.: Om de invloed van ruis en stringen te verminderen, dient u nooit een hogere gevoeligheid te kiezen dan strikt noodzakelijk is.

RF-ingang (alleen PM 6668)

Een laagohmige (50 ohm), wisselspannings gekoppelde ingang voor sinussignalen met frequenties van 70 MHz tot 1 GHz.

De microcomputer van de teller signaleert de aanwezigheid van een RF-signaal en kiest deze ingang automatisch. Indien geen RF signal gesignaleerd wordt, wordt met het LF kanaal gemeten. Hierdoor kan men hetzelfde signaal aan beide ingangen aansluiten met een T-verbinding. Zie onderstaande figuur.

De teller schakelt dan automatisch tussen de twee ingangen als de signaalfrequentie verandert, bijvoorbeeld als er een frequentiezwaaai gemeten wordt. Meer gegevens over het ingangssignaal worden in de technische specificaties gegeven.

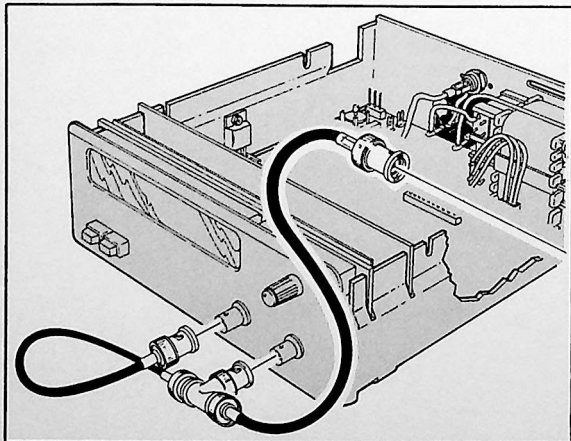

LF-ingang

Een hoogohmige (1 Mohm), wisselspannings gekoppelde ingang voor signalen met frequenties van 10 Hz tot 120 MHz. Een **auto-trigger circuit** zorgt ervoor dat op alle signaal vormen (zowel sinus als smalle pulsen) op de juiste wijze getriggerd wordt.

EXTERNE STANDAARD of BATTERIJ

BNC-ingang voor externe tijdbasisstandaard, of, als extra, batterijbus voor externe batterij.

Netspanningsaansluiting

Ingang voor netspanning. Gebruik altijd het drieadrig netsnoer dat met de teller meegeleverd wordt.

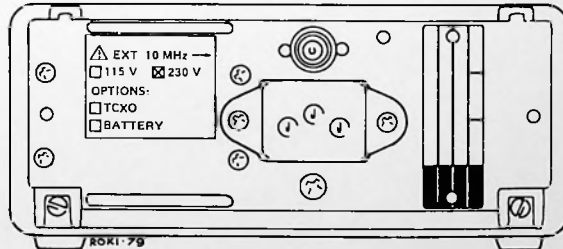
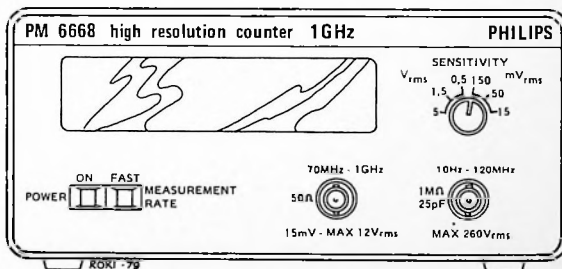
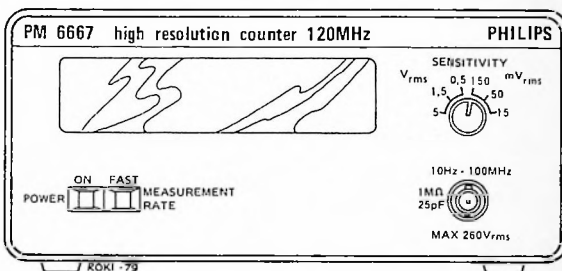

Service part

Line voltage setting	41
Technical description	41
Performance check	42
Adjustments	44
Replacing parts	45
Trouble-shooting, circuits diagrams and spare parts	46

Service part

9. Line voltage setting

The instrument can be set to 115V or 230V. On delivery, the instrument is set to the line voltage as indicated at the rear of the instrument.

The instrument is protected by a thermal fuse located in the line transformer.

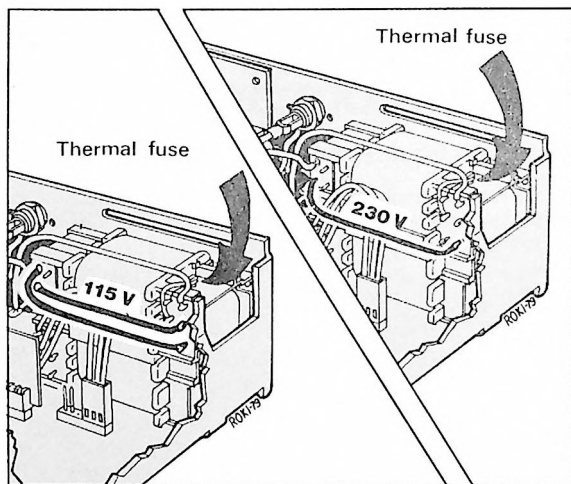

10. Technical description

10.1. Principles of the computing reciprocal counter

Fig 10.1 and 10.2 illustrate the difference between a conventional counter and a computing reciprocal counter.

In the conventional counter the input cycles are totaled in the decimal counting unit during a well defined time, the gate time e.g. 1 s or 0.1 s.

With a high frequency at input, more counts are accumulated than with a low frequency and hence the relative resolution will increase with increased frequency.

The computing reciprocal counter, however, has two counting registers, one totalizing the number of input cycles (Event counter) and the other one (Time counter) totalizes, during the same time, the number of 10MHz cycles from the reference oscillator.

The correct frequency is then computed by the microcomputer

$$(\mu C) \text{ as } f_{\text{displayed}} = \frac{\text{Event counts}}{\text{Time counts} \times 10^{-7}}$$

The resolution is depending on the 10MHz clock frequency together with the measuring time, and in PM 6667 and PM 6668 this means a resolution of ± 1 Hz in 10MHz (i.e. a relative resolution of 10^{-7}) with measurement rate in normal mode (1s measuring time).

Conventional frequency counter

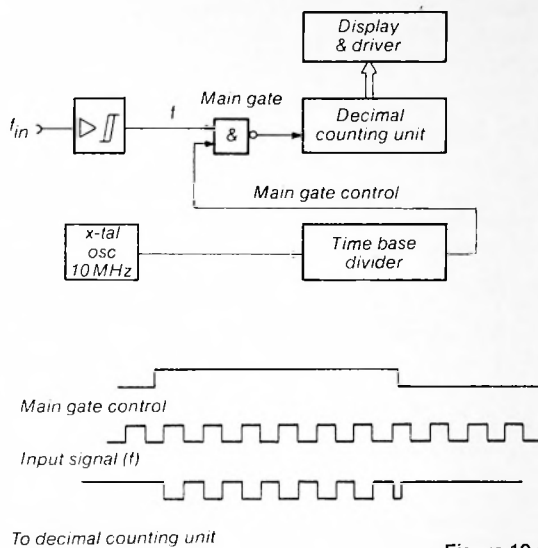
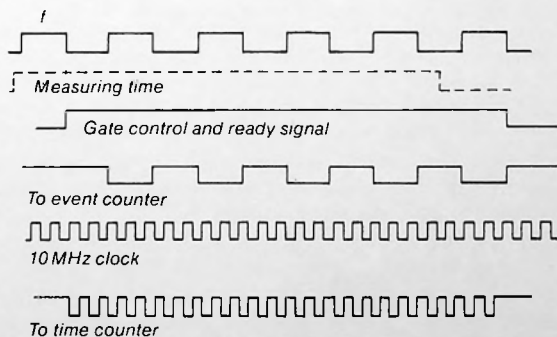
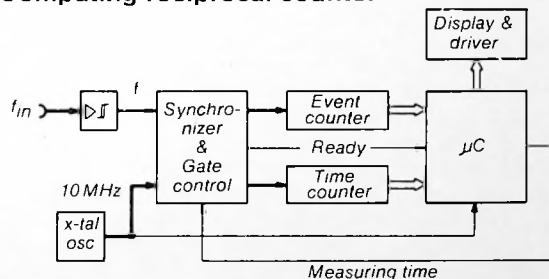

Figure 10.1.

Computing reciprocal counter



$$f_{\text{displayed}} = \frac{\text{Event counts}}{\text{Time counts} \times 10^{-7}}$$

Figure 10.2.

The resolution is hence not affected by the fact that the input signal is prescaled before being gated in the main gate.

The traditional \pm one count error will be only one cycle of the 10 MHz reference frequency since the signal to be measured is controlling the main gate (just like in a conventional period measurement).

10.2. Block diagram description

See figure 10.3.

In PM 6667 and PM 6668 the LF input frequency is first divided by 10 before the gating takes place. In the RF input (PM 6668 only) the division factor is 256.

This, however, does not influence the measurement resolution of $\frac{10^{-7}}{\text{measuring time (s)}}$

These dividers are actually parts of the period averaging and are compensated for by the μC .

The LF input circuit contains a traditional FET input circuit and a 6-position step attenuator. Next, a special patented AUTO TRIGGER circuit takes care of all possible duty factors and polarities. The AUTO TRIGGER circuit automatically offsets the trigger circuit to compensate for the DC offset caused by variations in the duty factor of the input signal. The principle of operation of the AUTO TRIGGER circuit is illustrated in figures 10.4.

Two Schmitt triggers "A" and "B" (fig. 10.4) are used in the trigger circuit. "A" has a zero-offset hysteresis band. "B" has two locations of the hysteresis band, B_{HI} and B_{LO} . The offset of the hysteresis band (B_{HI} or B_{LO}) is controlled by the output state of Schmitt trigger A.

Assuming that the hysteresis offset is B_{LO} and the input signal intersects point (1), the output of trigger "A" goes high. This makes that the hysteresis band will be offset to position B_{HI} . The subsequent pulses will then trigger the Schmitt trigger B correctly at points (2), (3) and (4) etc.

The first pulse in the pulse train is, as we see, used to correct the offset of Schmitt trigger B if that is necessary due to a wrong position of the offset in the initial state.

At negative polarity of the input signal the triggering sequence is the same but hysteresis band B_{LO} is now used. At cross-over point (7), trigger "B" will switch over to B_{LO} . The Schmitt trigger B will then trigger at points (8), (9) and (10) etc.

At symmetrical input waveforms the Schmitt triggers will operate as shown in fig. 10.4.

The central part of the counter is the microcomputer (μC). It controls the SYNCHRONIZER & GATE CONTROL by the "measuring time"-signal. When this signal goes high the next input cycle opens the input gates (synchronous with the input signal). After elapsed measuring time the next input cycle will close the input gates (again synchronous with the input signal).

The counting registers incorporated in the μC are used for the main part of the TIME COUNTER. However, the 8-bit counter outside the μC forms the fastest part.

The EVENT COUNTER consists of a 2-bit binary counter followed by two quad decades forming an 8-decade counter.

The driving circuitry for the liquid crystal display (LCD) is based upon a special driving circuit. Three such circuits are used as serial to parallel converters. The display information is transmitted on one line and is then stored in the shift registers of the LCD driver. The driver also contains the necessary oscillator and driver systems to drive the LCD in a proper AC mode.

The LCD contains 7 digits, 11.5 mm high, decimal point and unit indications.

The HF input of the PM 6668 has a PIN diode arrangement to attenuate high amplitudes and to provide also an overload protection. The integrated amplifier (similar to the amplifier at the LF-input) is followed by a detector and the divide-by-256 circuit. The DC output from the detector is fed to a comparator, which generates an output signal "HF disable" to the μC . The μC generates a return signal "LF enable" which is high if no HF signal is present. When the frequency of the HF signal is high enough, the "LF enable" signal goes low, enabling the HF channel. Hence, the HF signal will be counted automatically if it is available simultaneously with an LF signal.

Both counter models operate from a single 5V power supply. An optional built-in battery supply is available.

11. Performance check

11.1. Test equipment

- 1 RF-millivoltmeter or a 50 ohm input oscilloscope or any other level meter ranging up to 120 MHz for PM 6667 and to 1 GHz for PM 6668.
- Sinewave generator with a 50 ohm output 10 Hz ... 120 MHz (PM 6667), 10 Hz ... 1 GHz (PM 6668).
- 1 BNC T-piece.
- 3 Coaxial cables with 50 ohm impedance.

11.2. Low frequency input

(1 M ohm)

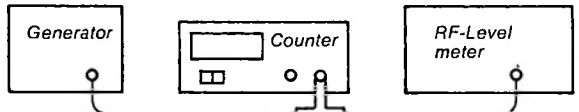

Use as short cables as possible!

- Set the sinewave generator to a voltage of 15 mV_{RMS} and with a sensitivity setting on the counter of 15 mV_{RMS}. Check that counter correctly displays any value in the range 100 Hz ... 75 MHz.
- Adjust sinewave generator output to 25 mV and check that counter displays correct values at 10 Hz and at 120 MHz.

11.3. High frequency input

(50 ohm, PM 6668 only)

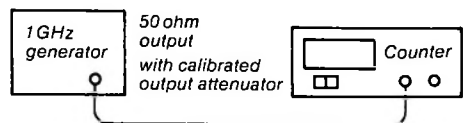

- Set signal generator to a voltage of 15 mV_{RMS} (-24 dB) and check that counter correctly displays any value in the range 70 MHz ... 800 MHz.
- Set the generator output to 25 mV_{RMS} (-19 dB) and check that counter displays correct value at 1 GHz.

Block diagram PM 6667 and PM 6668

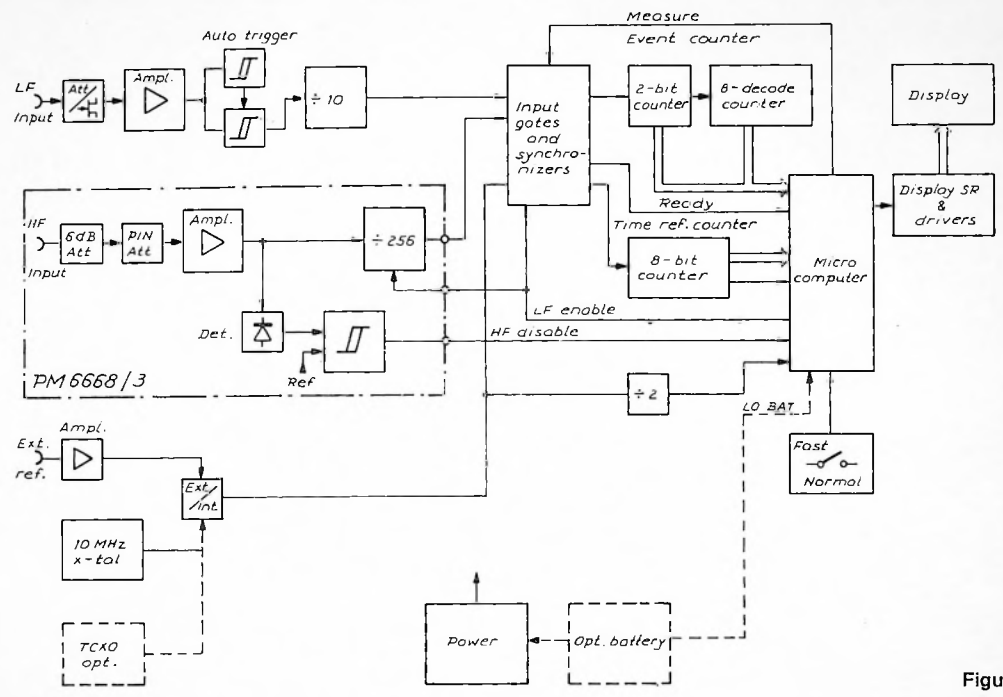

Figure 10.3.

Auto trigger operation (patented)

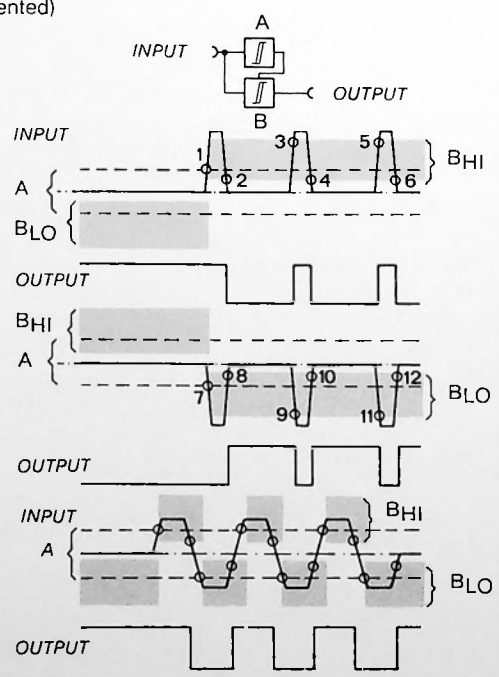

Figure 10.4.

Traditional trigger operation

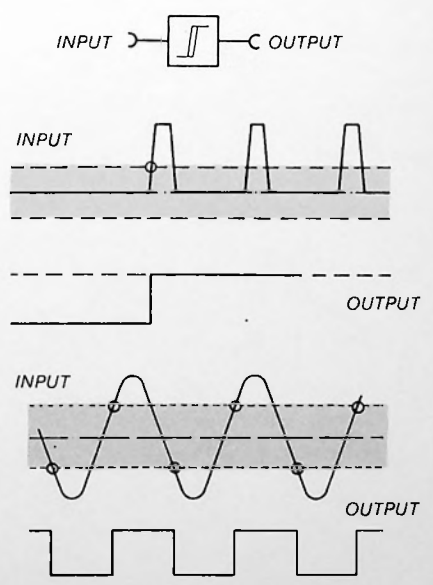

Figure 10.5.

12. Adjustments

12.1. Frequency adjustment of standard oscillator (Models PM 6667/01, PM 6668/01)

Equipment required:

10MHz reference signal, inaccuracy $\leq 1 \times 10^{-6}$

Note: adjustment should preferably be made at an ambient temperature of +25°C (+77°F) after 1h warm up.

- Remove housing.
- Connect reference signal to LF input.
- Adjust C110 to read 10MHz ± 10 Hz on display.

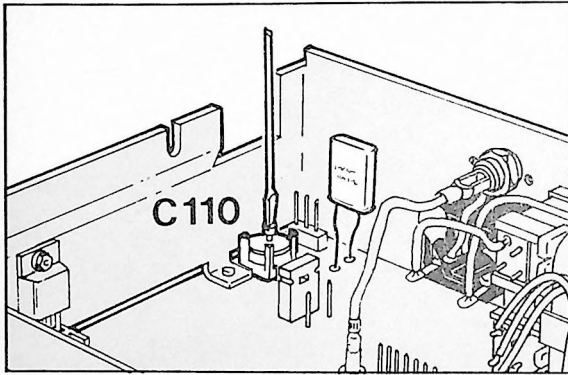

12.3. DC balance adjustment

Equipment required:

LF sinewave generator and LF oscilloscope.

- Connect sinewave generator (set to approx. 1 kHz and 30mVRMS) to LF input of counter.
- Connect oscilloscope between pin 7 of IC103 and ground.
- Adjust R104 until displayed square-wave has a duty-factor of 0.5.
- Decrease input amplitude to 15mVRMS and fine-adjust R104 for a dutyfactor of 0.5 on oscilloscope display.

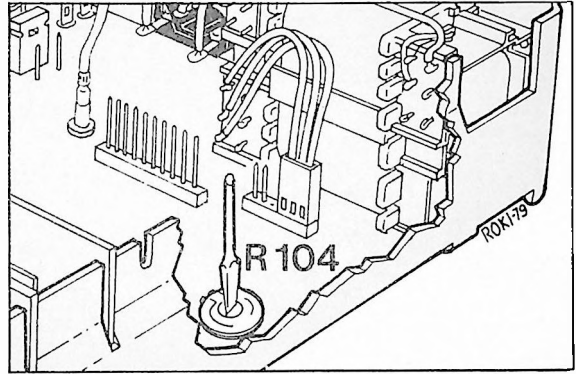

12.2. Frequency adjustment of TCXO (Models PM 6667/02, PM 6668/02)

Equipment required:

10MHz reference signal, inaccuracy $\leq 1 \times 10^{-7}$.

Note: adjustment should preferably be made at an ambient temperature of +25°C (+77°F) after 1h warm up.

- Remove housing.
- Connect reference signal to LF input.
- Adjust C106 to read 9999.999kHz on display.

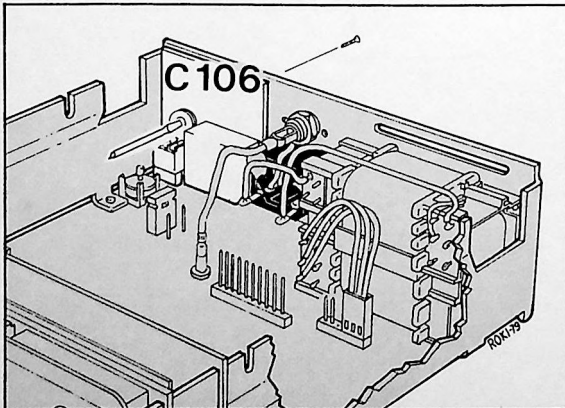

12.4. RF enable adjustment (PM 6668 only)

Equipment required: 1GHz signal generator

- Connect signal generator to RF input of counter.
- Set signal generator to 70MHz and 15mVRMS.
- Check that counter displays a stable 70 MHz read-out.
- If there is no read-out, adjust R317.
- Set signal generator to 500MHz and 800MHz. Check read-out at each frequency and adjust R317 if required.
- Set signal generator to 1000MHz, 25mVRMS and check read-out.
- Repeat the procedure and readjust if required.

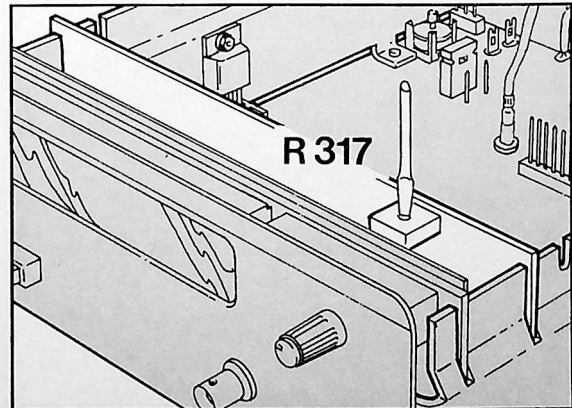

12.5. Battery unit adjustment

Equipment required:

Digital voltmeter

- Connect voltmeter between pin 2 of IC 103 and ground.
- Adjust R117 until voltage is $+2V \pm 50mV$.
- Remove fuse VL101.
- Connect voltmeter to plus pole of battery and ground and adjust R116 until voltage is $+6.9V \pm 50mV$. (at $+20 \dots +25^{\circ}C$)
- Reinstall fuse.

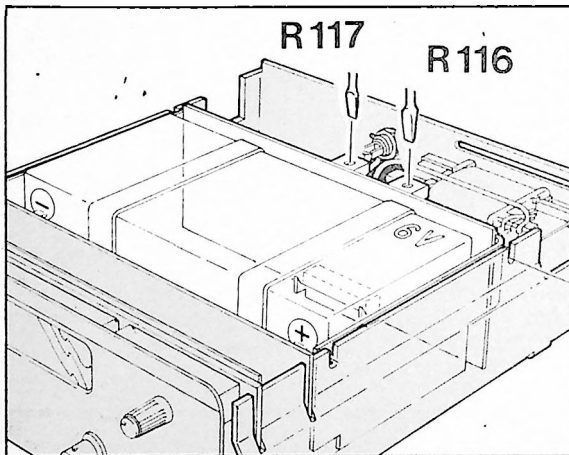

13.2. Fuse replacement

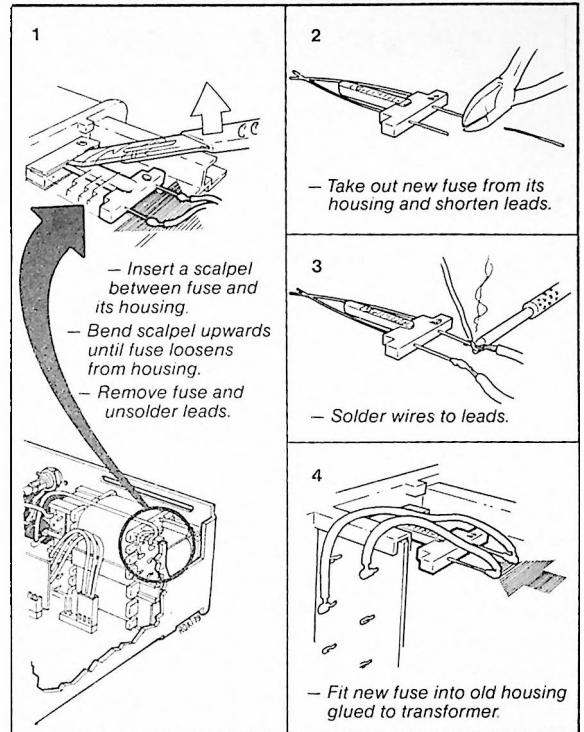

13. Replacing parts

13.1. Battery replacement

- Loosen the four side-wall screws and remove battery unit.
- Remove screws at holding brackets.
- Detach fast-on connectors.
- Pull up battery.

Note: Check that the plus pole of the new battery is at the right-hand side (viewed from battery connector side).

See figure below.

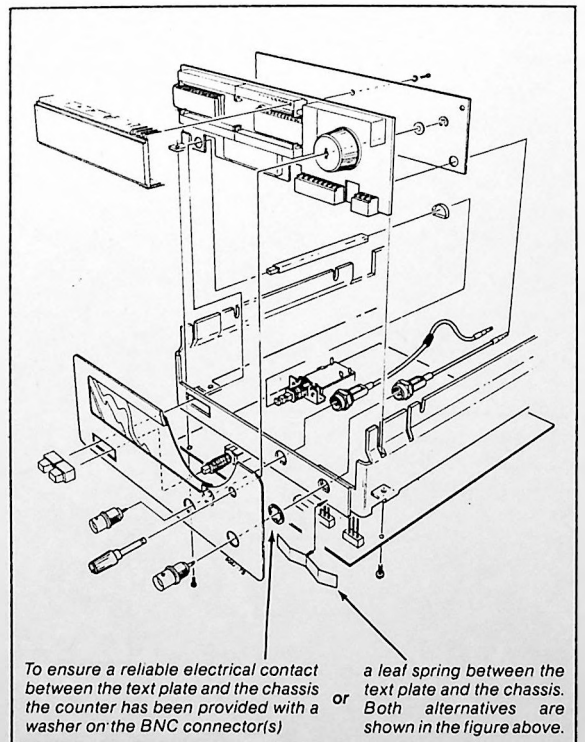
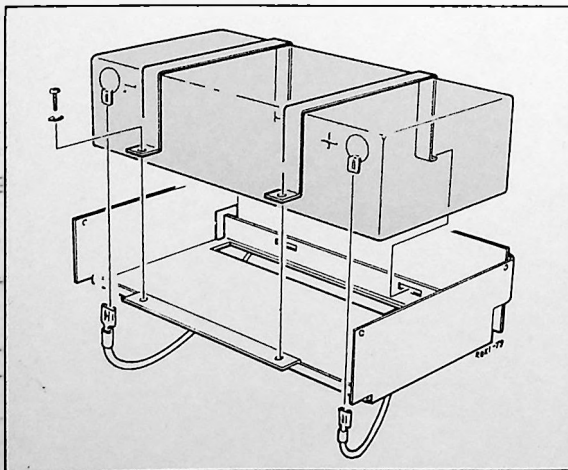

14. Trouble-shooting circuit diagrams and spare parts

General

The PM 6667 and PM 6668 are provided with a built-in self-diagnosis routine that is performed when the counter is switched on. If certain faults are present, this is shown on the display as one of six error codes, i.e. "Error 1" through "Error 6".

The fault-finding diagrams Error 1... 6 make it possible to isolate the fault to the microprocessor, certain IC's or other sources.

"Conventional" faults occurring in, e.g., the power supply or the input circuitry are normally not generating an "Error" indication.

If the counter does not operate properly, switch off the power and then switch on again. Check whether an error code is displayed. If not, trouble-shoot in the conventional way (measure DC voltages, check waveforms etc.). If an error code is displayed, check the relevant diagram.

The "Error" indication can be removed as follows:

- Ensure that an input signal is connected.
- Press or release the MEASUREMENT RATE button once or a couple of times.

Unless the fault has been remedied, the "Error" code is displayed again as soon as the counter has been switched off and then on again.

Self-check at Power On

Once Power On has been switched on, the μC performs a self-check including a diagnosis routine. The self-check consists of three parts:

- 1 Test of program memory by means of software signature analysis of the μC .
- 2 Test of data memory.
- 3 A test that the μC can set the external logic to zero.

All segments, decimal points and units are visible on the display during the test. This makes it possible for the operator of the counter to check the function of the display.

If the test fails during the test of program memory or data memory, the code Error 1 will be displayed.

If, however, the test that the μC can set the external logic to zero fails, there will be an Error code between 2 and 6 depending on where the faulty part is.

NOTE: The diagrams illustrate the faults that are most likely to occur in the microcomputer circuitry. Other fault combinations may be possible which also generate an "Error" code or a non-sense display read-out.

Always check the DC supply voltage before any replacements are made!

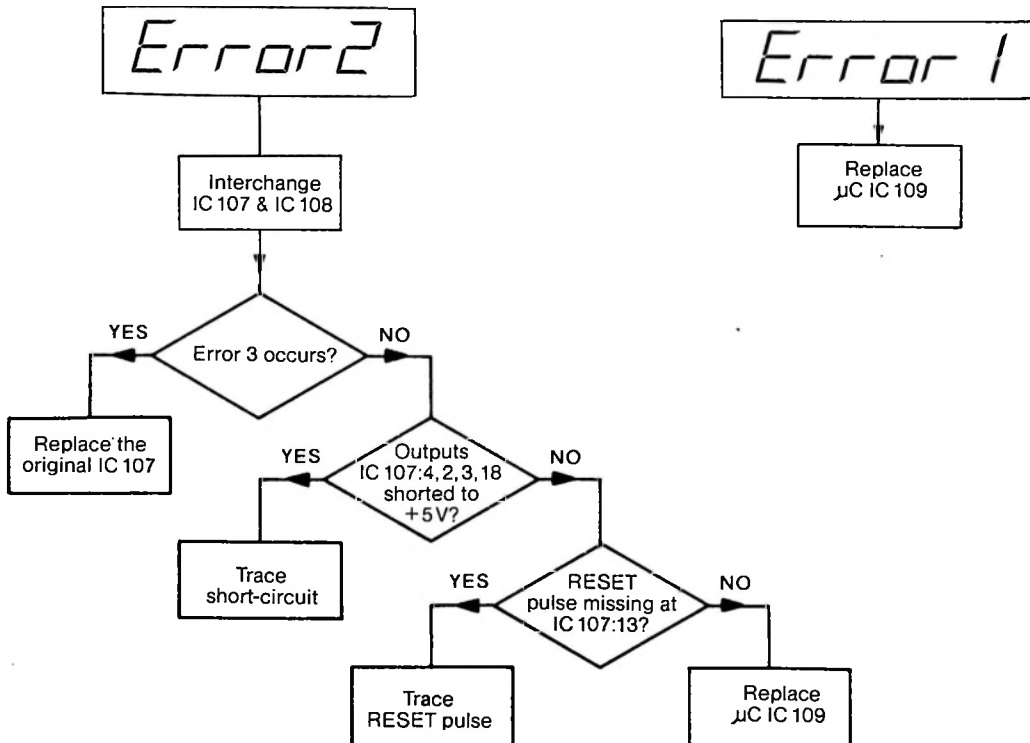

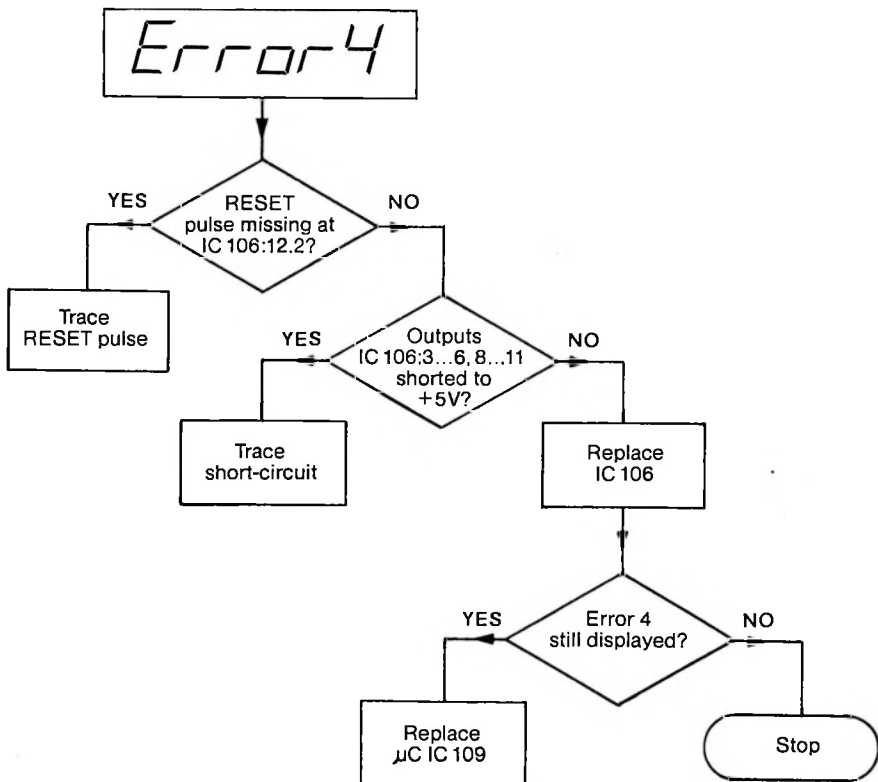
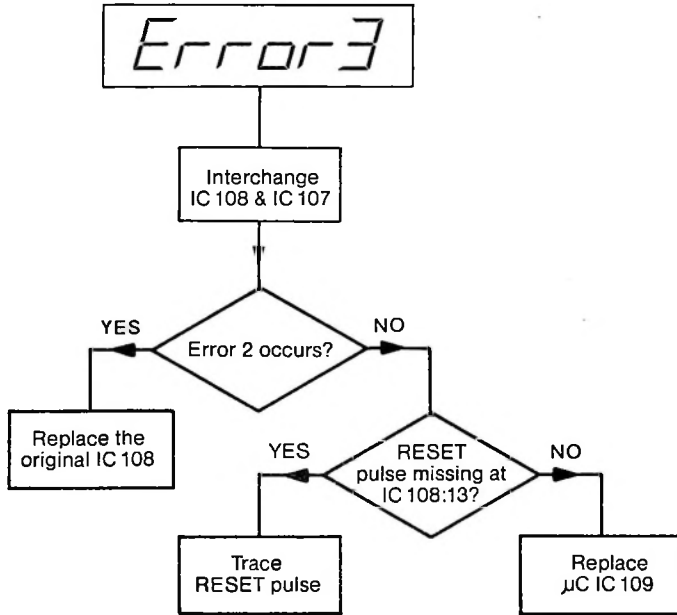

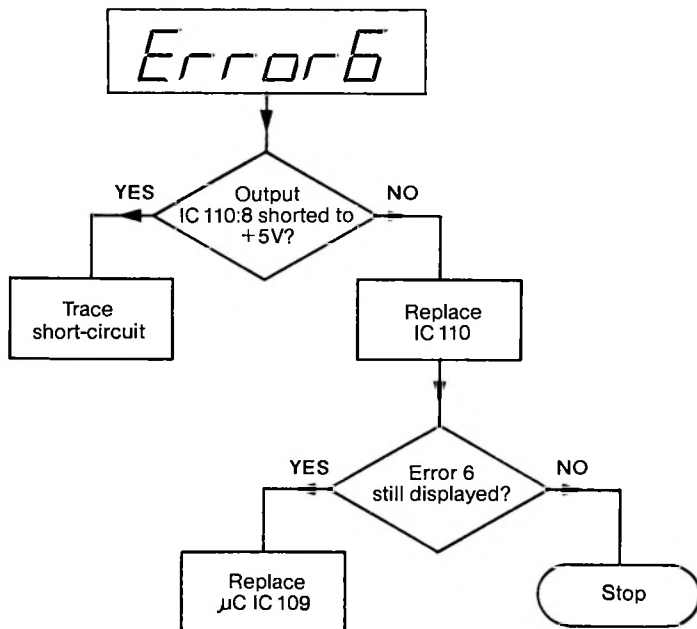
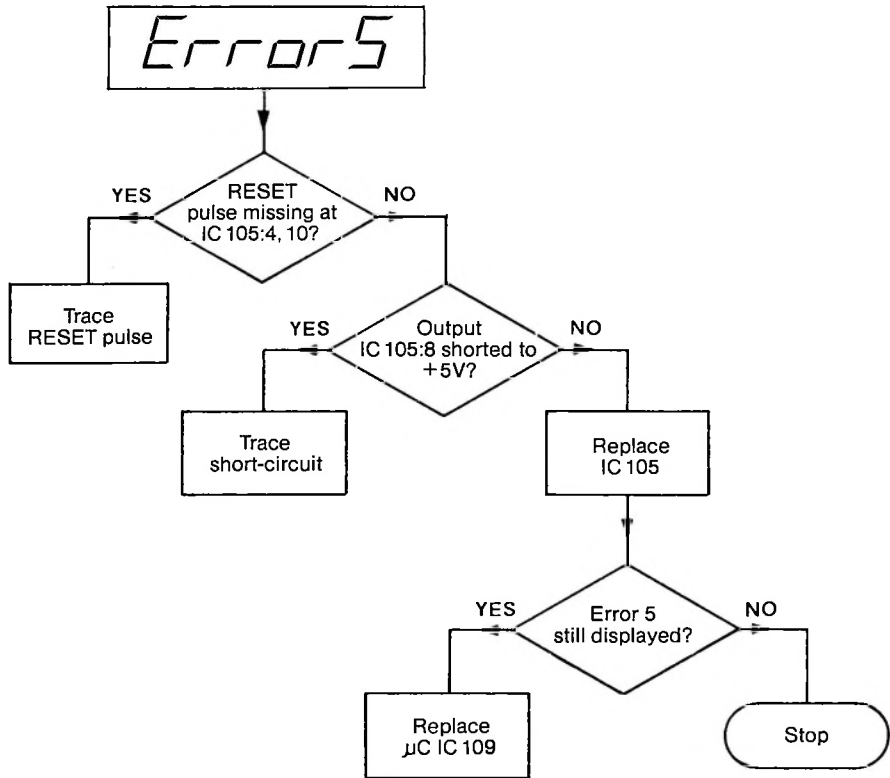

The Microcomputer

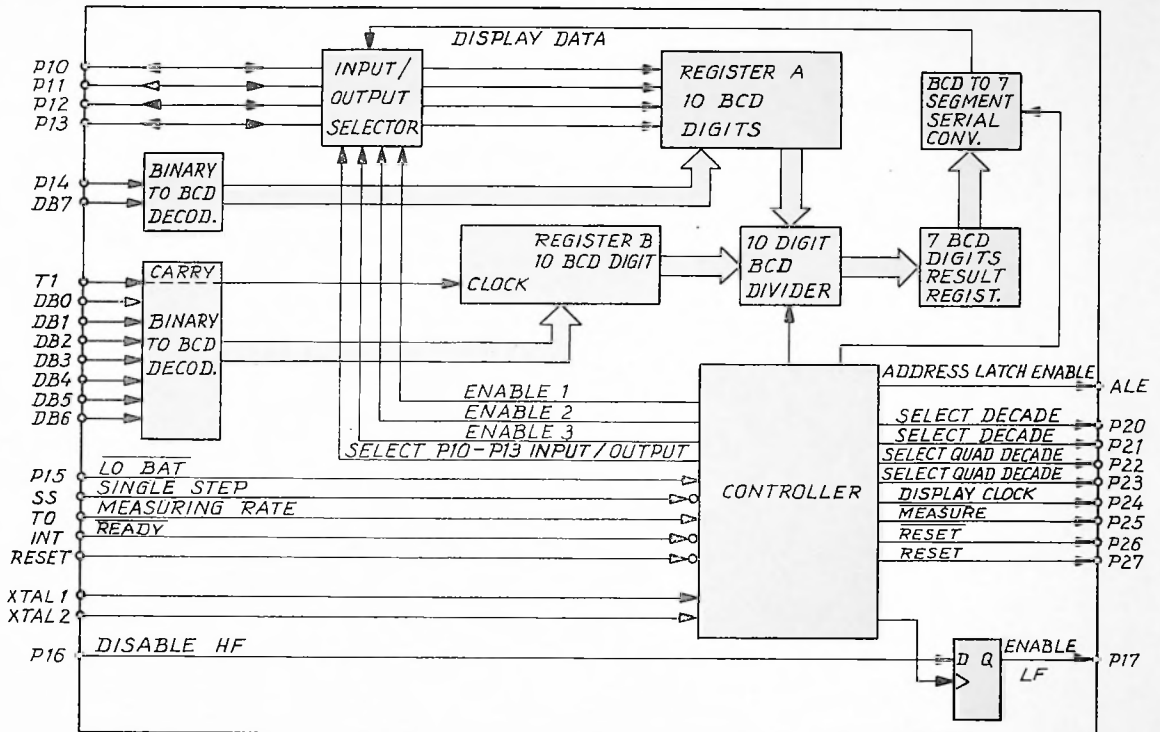

Application block diagram.

How the result is calculated and the presentation is done

By programming the μC with a program that controls measurements, performs calculations and presents the result on the display, the μC has got an application with well specified functions. This application of the 8048 μC is illustrated in the "Application block diagram of the μC ". This description is based upon this illustration, the "Functional diagram" and the "Signal path diagram".

The Controller performs all communication of control signals, internally in the μC as well as externally with the rest of the logics in the counter.

The pins P10—P13 can be used both as inputs as well as outputs. The mode in which they shall work is decided by the controller and executed by the "Input/output selector".

After elapsed measuring time the result of the event signal is kept in the Event counter, IC 105, 107, 108 and 110.

The result in the two divide-by-2 counters IC105 and IC110 are transferred to P14 and DB7. It is converted from binary notation to BCD code and stored in "Register A".

The result in the two Quad decades IC107 and IC108 are transferred to the pins P10—P13. The controller sets them to be inputs. The controller also sets the pins P20—P23 so that the μC

can read the content in every single decade within each Quad decade. The result is stored in Register A together with the result from the two divide-by-2 counters.

The Timer Counter has two registers. One register with 256 bits, ≈ 2.5 digits, in IC 106 to take care of the 10 MHz signals. The other one in the "10 BCD digit Register B". The carry signal from IC106:8 has a frequency of 10 MHz divided by 256. The carry signal is connected to T1 and is counted and registered in Register B. After elapsed measuring time the result in IC106 is transferred via T1 and DB0—DB6 to the Register B after it has been decoded from binary notation to BCD code in the "Binary to BCD decoder".

The results in Register A and Register B are divided in the "10 digit BCD divider". After this calculation only the 7 most significant digits are stored in the "7 digit result register".

In the "BCD to 7 segment serial converter" the 7 BCD digits are transferred into 7 segment information in serial form. In this block the decimal point, units and LO BAT are added.

Via the "Input/output selector" the pins P10—P13, are set in output mode, the 64 bits display Data signal, the Enable1, 2 and 3 signals are transferred to the display driver circuits IC201, 202 and 203. To complete the necessary information to the display the controller sends out the "Display clock" signal on port P24.

The μC needs a clock signal

The external clock signal needed for the μC is a 5MHz signal taken from the 10MHz reference signal and divided by two in IC 110.

This 5MHz clock signal has nothing to do with the resolution and accuracy specification but it must always be present to get the μC running. It is important that the internal oscillator is operating since it can not be replaced with an external reference signal. The internal reference oscillator is either a standard crystal oscillator or an optional TCXO.

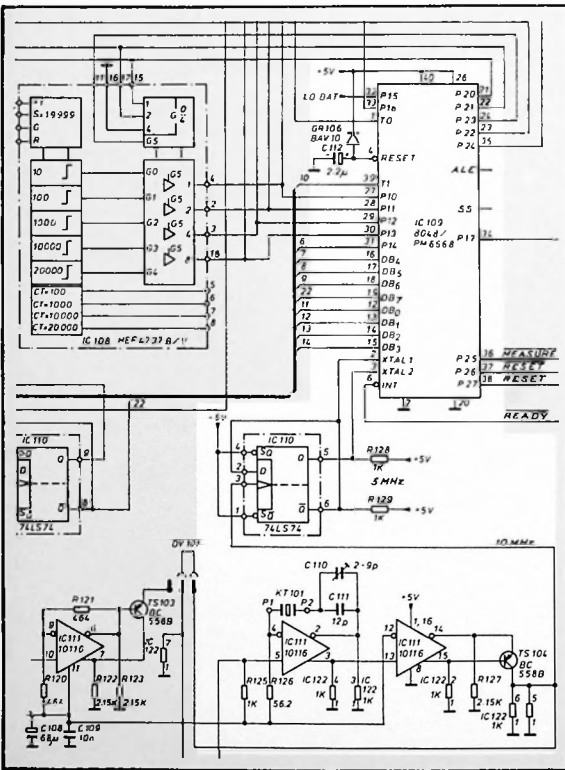

Five important pins on the μC IC 109

- Check that there is a 5 MHz signal on pin 2 and 3.
- If there is a 5 MHz signal on pin 2 and 3, there should be a 333.3 kHz pulse train on pin 11 having TTL levels.
- If there is no signal on pin 11, check that pin 4 is high. After POWER ON has been switched on and the +5V supply voltage has reached the +4.75V level, the capacitor C 112 will keep pin 4 low ($< +0.8\text{V}$) during at least 50 ms.
- If there is no signal on pin 11 and pin 4 is high, check that pin 5 is high. This is a single step input that makes the program stop when level is low.

Timing Diagram

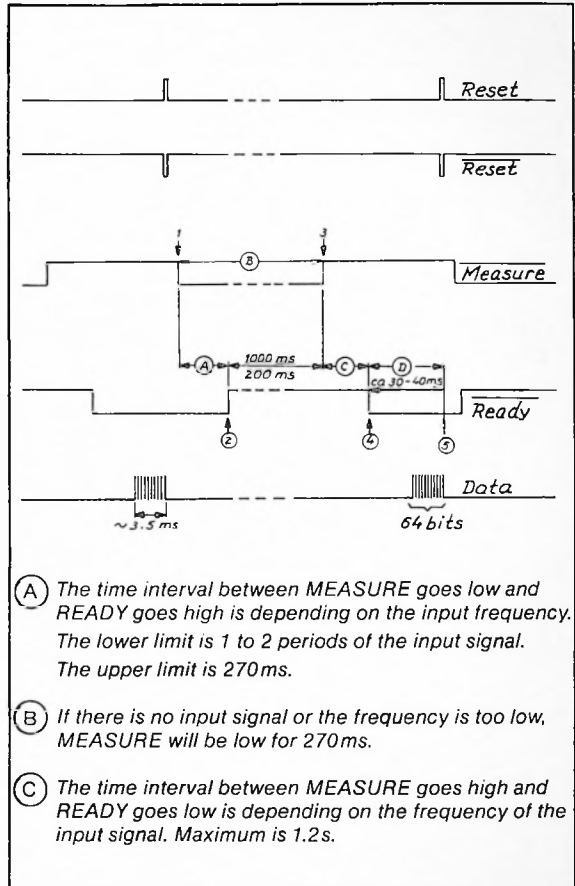

A new measurement cycle starts when MEASURE goes low ①, waiting for an event signal to occur. If no event signal occurs within 270 ms (A) the MEASURE goes high again. During the time MEASURE is low the μC is ready to start a new measurement cycle. If, however, an event signal occurs during the 256 ms waiting time, this will clock MEASURE to be a high READY signal ② at IC 105:2, 3, 6. The time when READY is high is the actual measuring time. During this time event signals are counted in the Event counter and the 10MHz reference signal is counted by the Time counter. Depending on whether FAST or NORMAL MEASUREMENT RATE is chosen, the μC sets the time for MEASURE to go high ③. The Synchronizer and Gate control ensure that only whole periods of the event signals are counted in the Event counter. The time interval ③ between MEASURE going high ③ and READY going low ④ is therefore depending on the input frequency. The time interval ③ is maximum 1.2 s. The time interval ④ between READY going low ④ and the 64 bits data are transferred to the display ⑤ is the computing time of 30–40 ms. During the computing time the result is calculated and transferred in serial form to the display.

Wrong display read-out

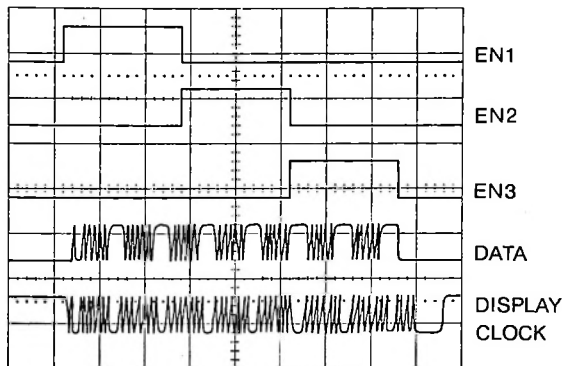

TTL levels 500 μ s/div.

Presentation of the zeros on the display.

- Step 1. Check the Data, Clock and Enable Signals to the Display PCB, according to the photo.
- Step 2. If step 1 is correct but there is still no read-out, check the Display PCB.
- Step 3. If step 1 is false, check the "Five important pins on the μ C".
- Step 4. If step 1 and the Display PCB is correct and there is still no significant read-out, the trouble is most likely found in the logic circuits on PCB 1.

How to measure on the Liquid Crystal Display

An LCD is working in an AC mode. IC 201, containing the Backplane oscillator, works in a master mode. IC 202 and IC 203 are slaves. The frequency of the Backplane oscillator is set to approximately 60 Hz by C 207.

As long as the segments are not visible the segment input and the back-plane are oscillating in the same phase and with the same frequency. When, however, the segments are visual (black) the segment input is oscillating 180° out of phase to the back-plane. This requires a two channel oscilloscope when trouble shooting the LCD. One channel is applied to the backplane BU 204:1 or 10 and is used as the trigger channel. The other channel is then used for fault finding the information flow from the display drivers to the LCD.

If the Backplane oscillator stops oscillating or a DC voltage is applied across the Backplane (BPD) and one or more segments for a longer time the LCD might be damaged.

Input Amplifier

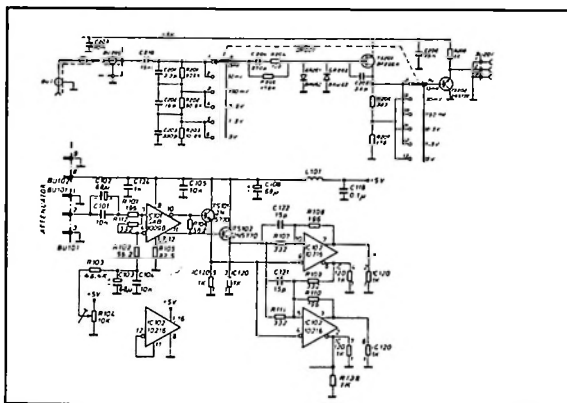

The input amplifier is divided into two parts on different PCB:s. The input network, the six-step sensitivity control and the impedance converter are located on U2. The amplifier and the auto-trigger are located on U1.

The sensitivity control consists of two parts. One three-step attenuator in the high impedance part and a two-step gain control of the impedance converter TS 201.

IC 101 is an integrated amplifier with fixed gain. The amplification is controlled by means of R 106 and R 112. R 112 is factory selected. To obtain higher amplification equal to more sensitivity, R 106 can be increased. The recommended minimum value of R 106 is 562 Ohms.

TS 101 and TS 102 acts as interface between IC 101 and the auto-trigger.

A description of the Auto Trigger is found in chapter 10.2. Block diagram description.

Synchronizer and Gate control

The μ C controls the timing of every measurement cycle via the Synchronizer and Gate control. This circuit synchronizes the start and stop of the event and time reference signals so that only whole periods of the event signal are counted. (See fig. 10.2).

The signal path through the Event and Time counters are indicated with blue in the signal path diagram.

The μ C reads the content in the Event counter and the Time counter after the measuring time has elapsed. This is indicated by the red signals in the signal path diagram. It calculates the result and converts it to a 64 bit serial information including clock and enable signals needed for correct presentation on the 7 digit LCD.

Signal path through the Event counter

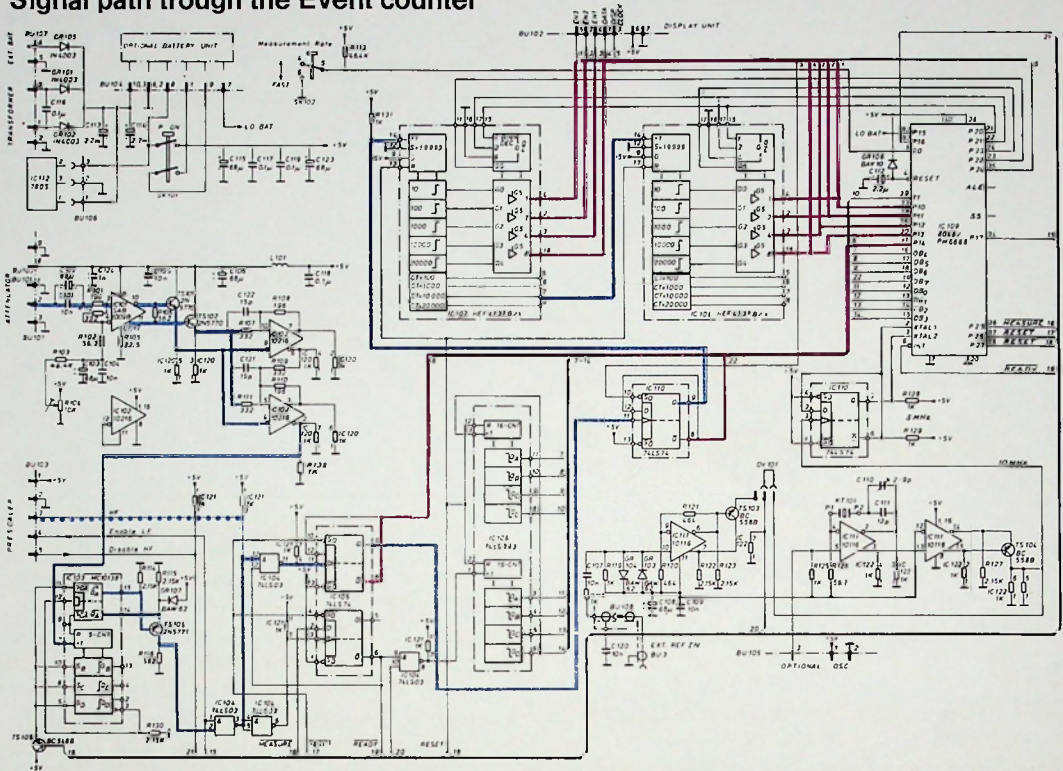

Signal path through the Time counter

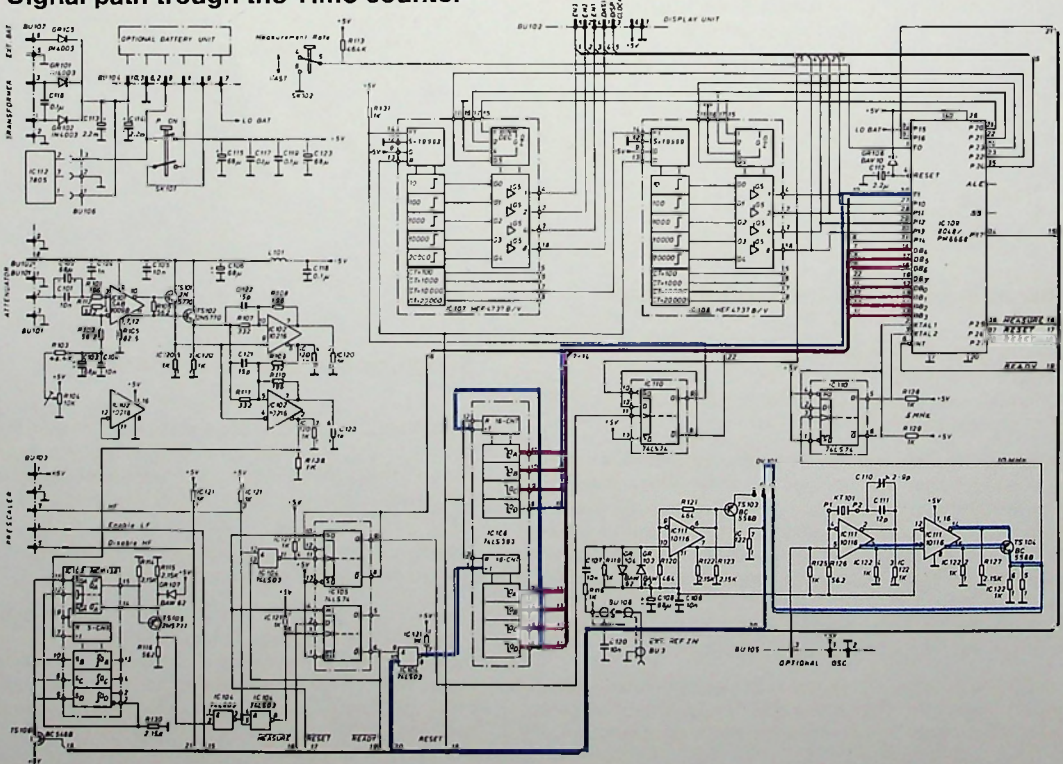

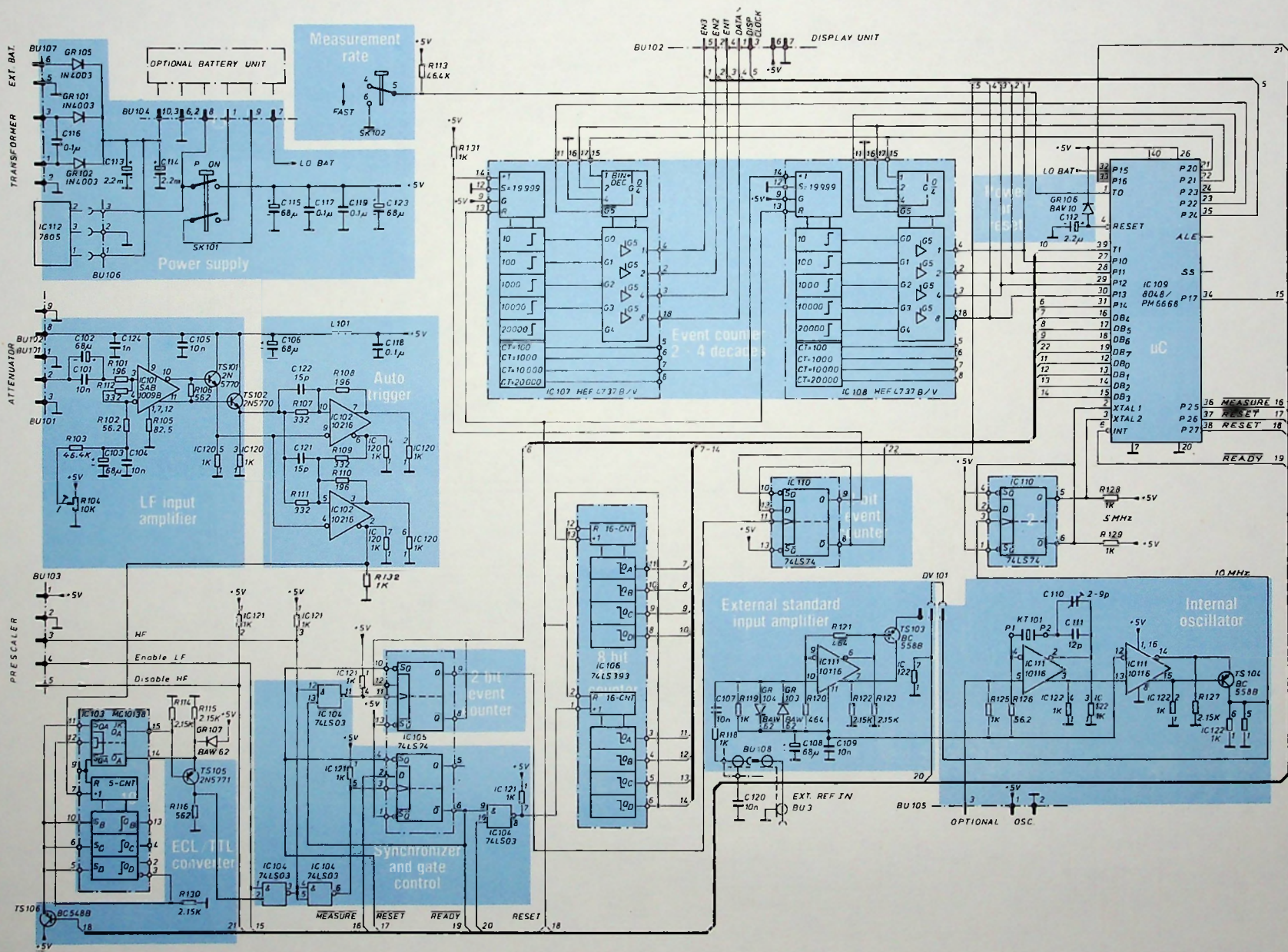

Functional block diagram Unit 1 53

Basic board Unit 1

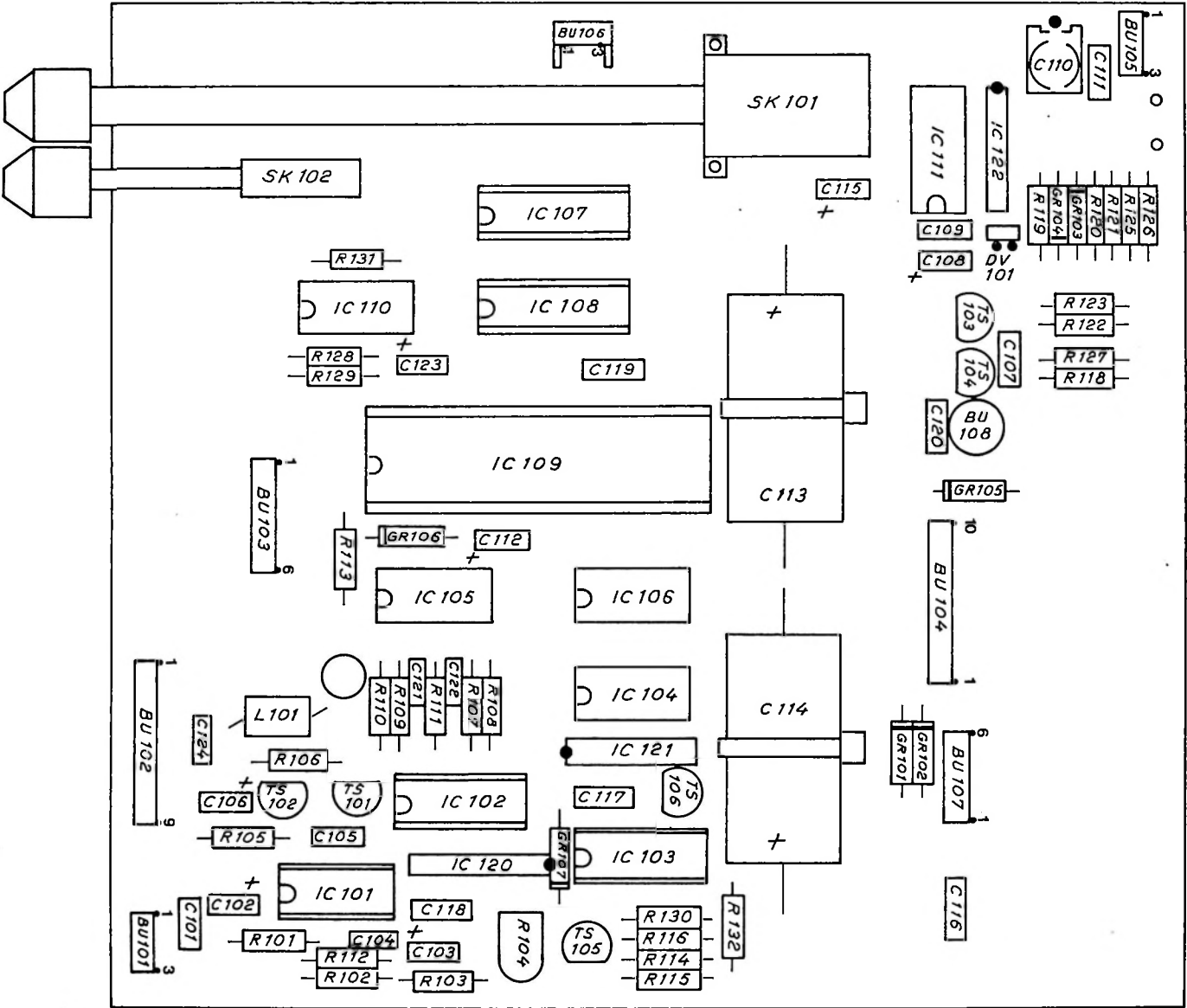

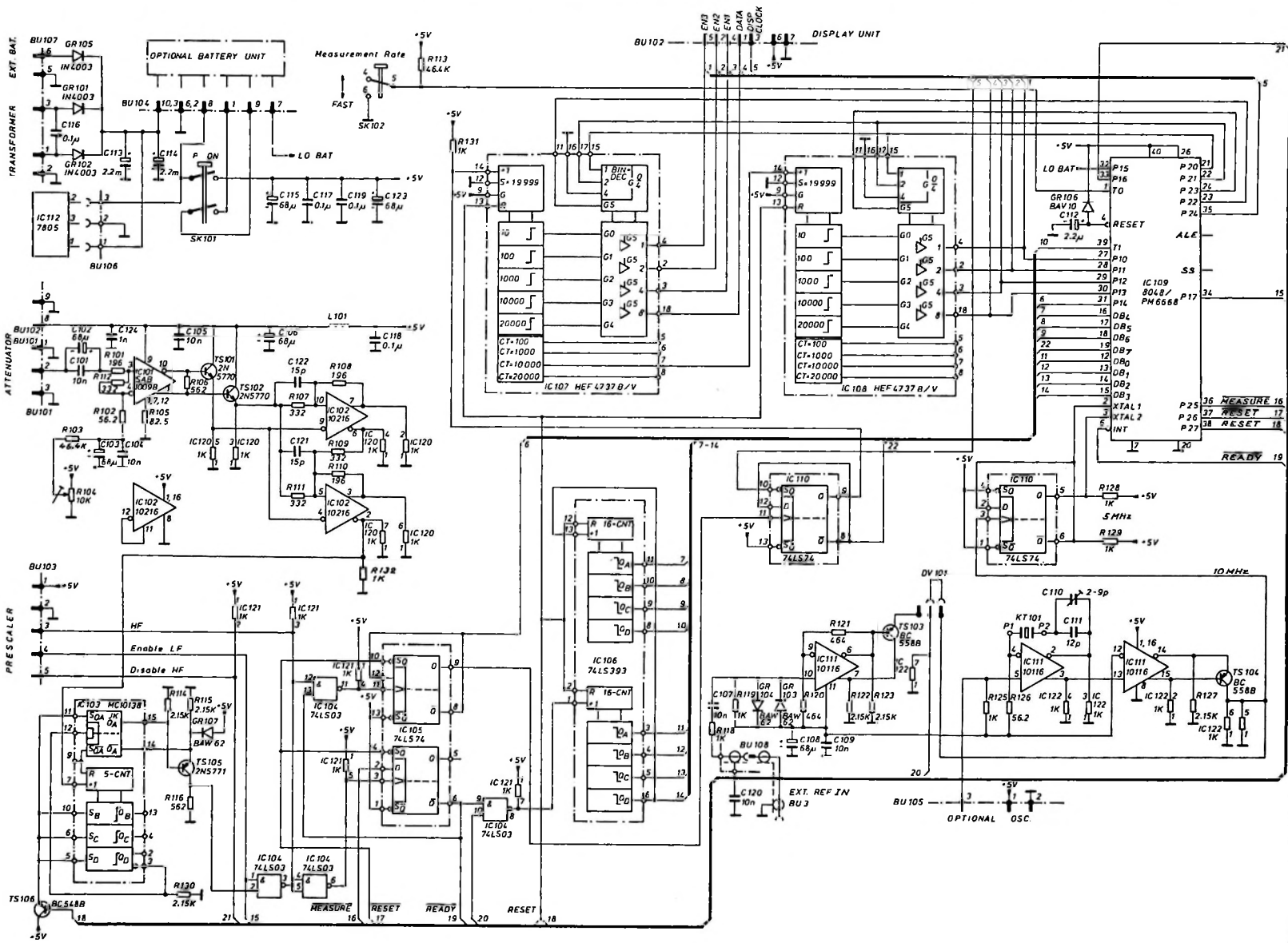

Basic board Unit 1

Input amplifier and display drivers Unit 2

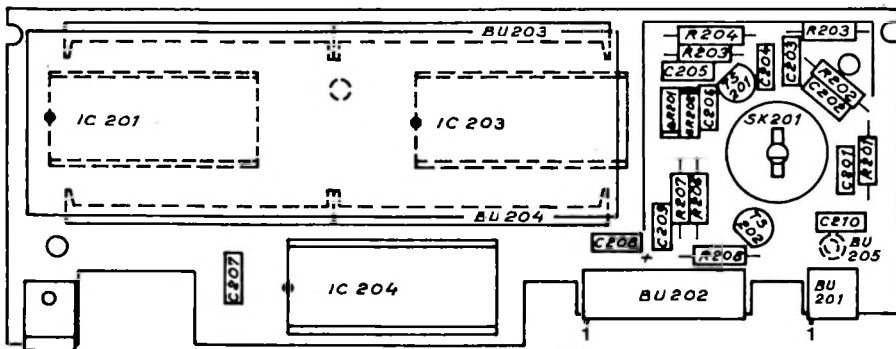
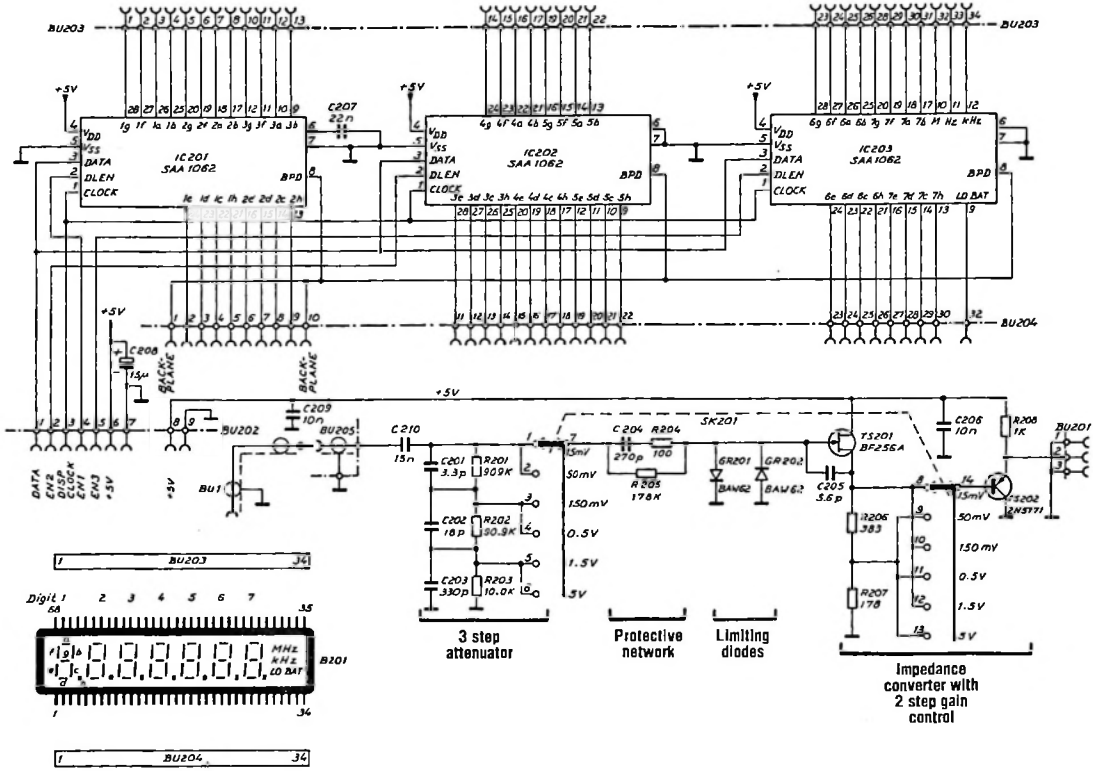

Prescaler Unit 3

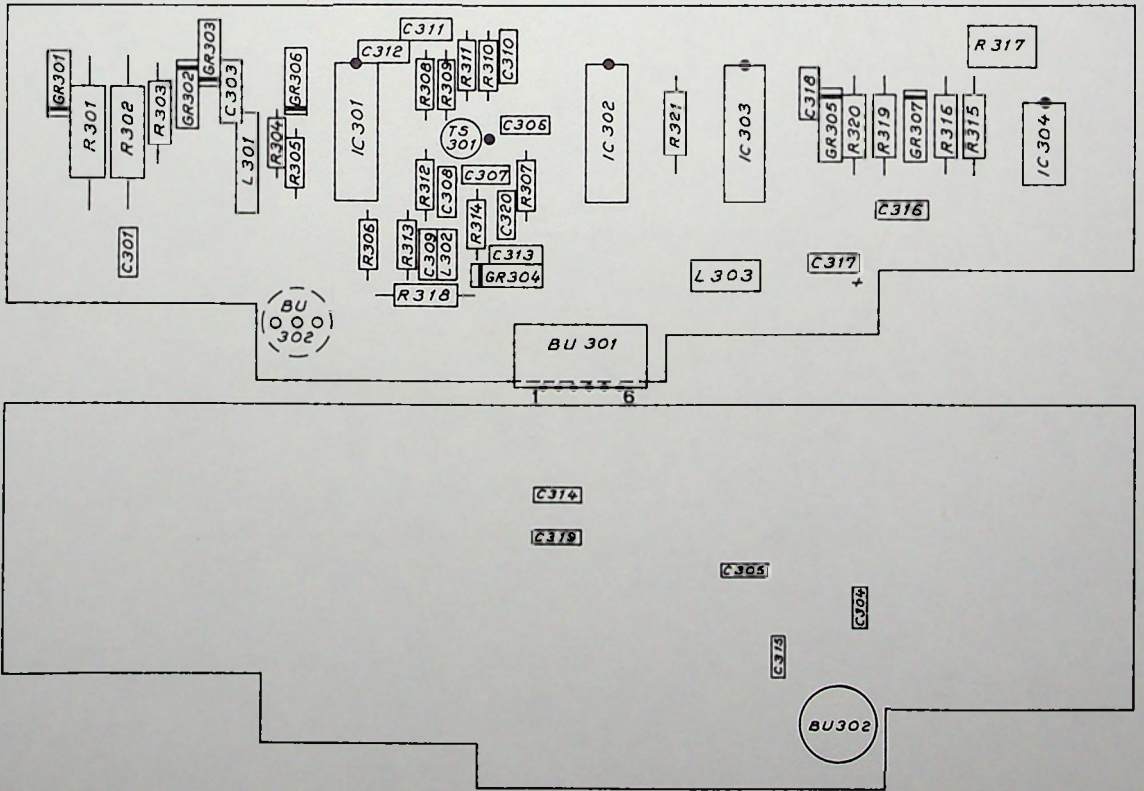
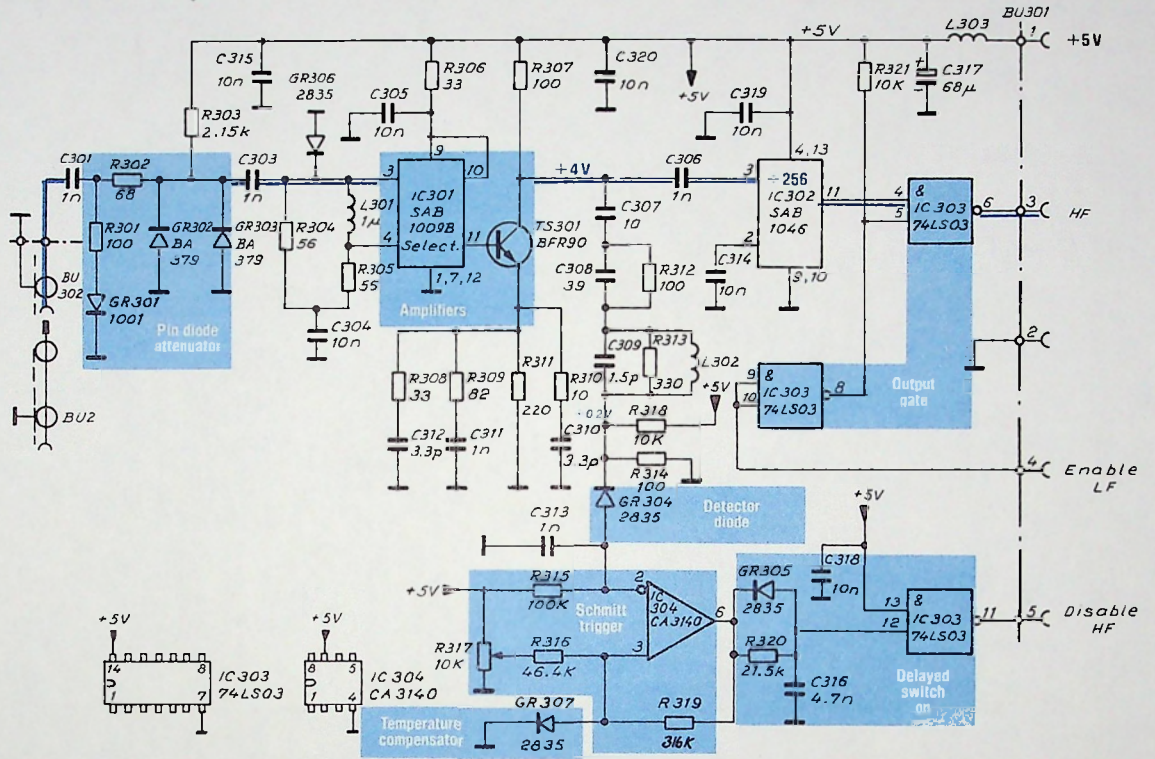

Optional battery unit PM 9601

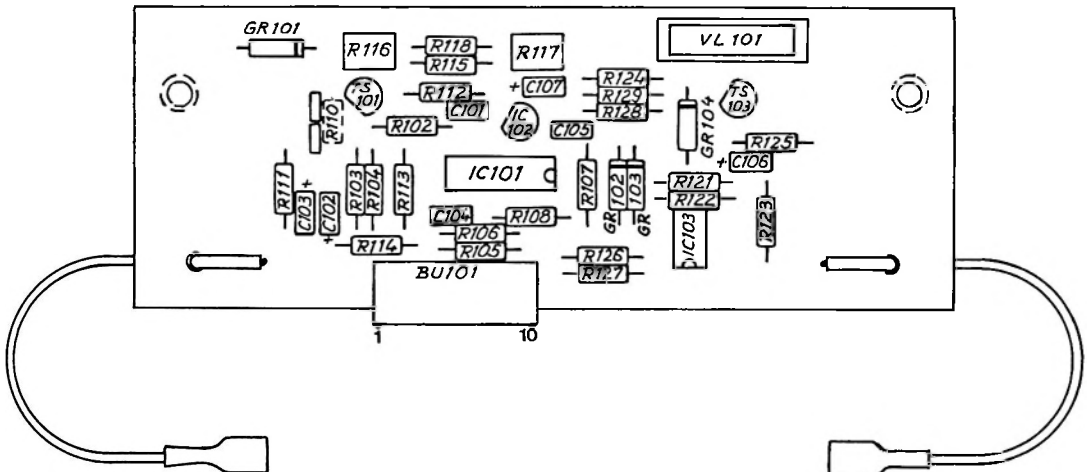
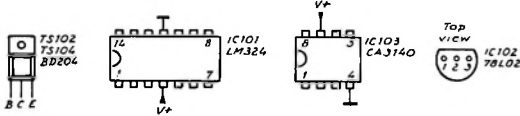
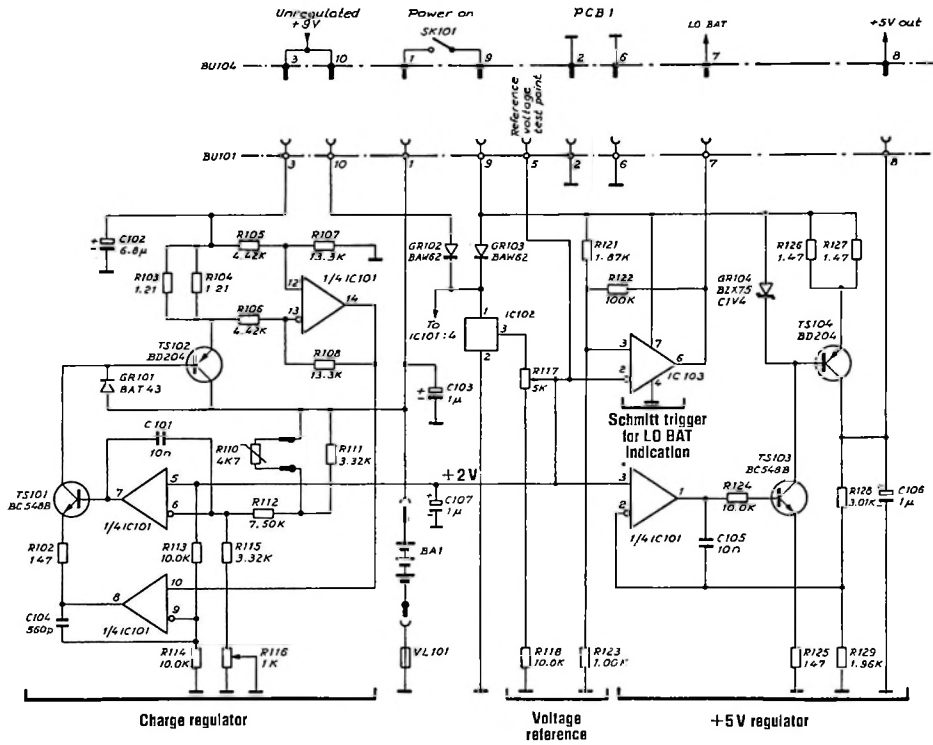

TCXO / 02

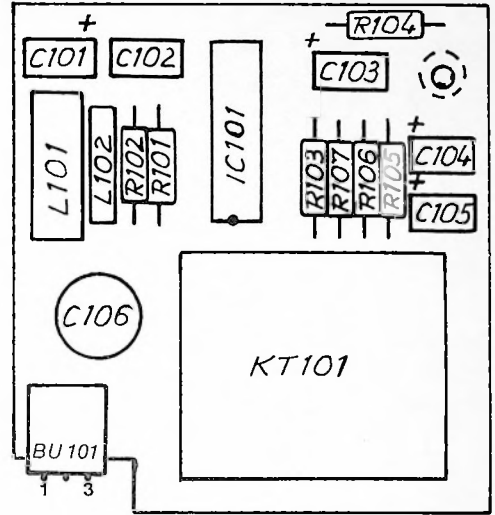
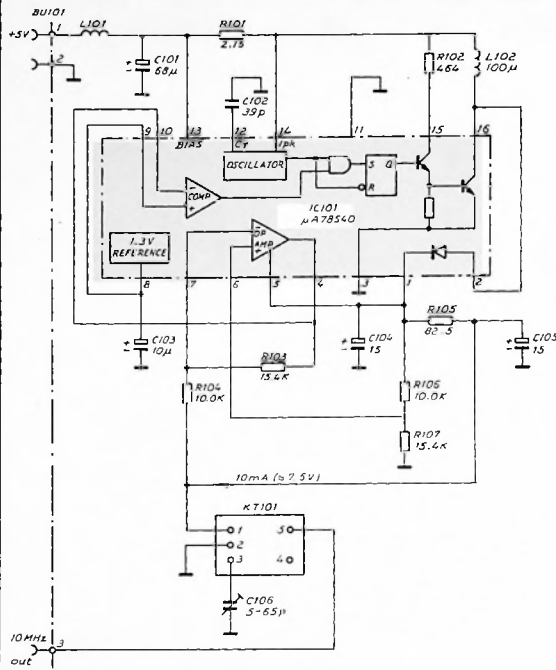

External battery jack and mains transformer

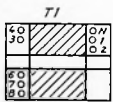

Mains voltage	Interconnect.
230V	2-3
115V	1-3, 2-4

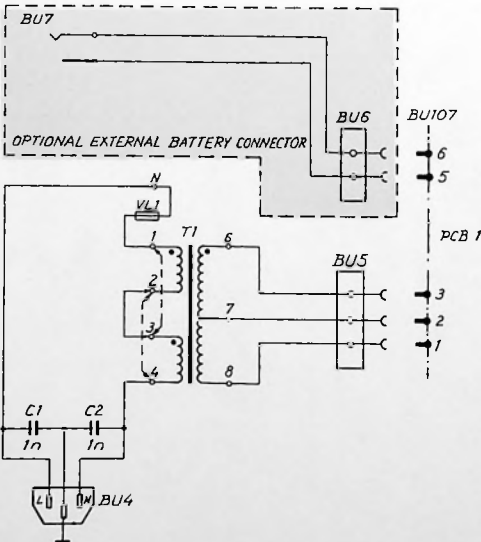

Lacquered Metal Film
Manufacturer: Philips
Type: MR30

P at 70°C: 0.5 W
 Tolerance: 1 %

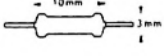

Ω	Ordering Number
909k	5322 116 54408

Ceramic Potentiometers
Manufacturer: Beckman
Type: Cermet 72X

P at 70°C: 0.5 W
 Tolerance: 10%

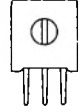

Ω	Ordering number
1 k	5322 101 14299
5 k	5322 101 14301
10 k	5322 101 14254

Carbon Film
Manufacturer: Philips
Type: CR16

P at 70°C: 0.2 W
 Tolerance up to 220 k: 5 %
 Tolerance from 270 k: 10 %

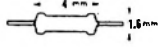

Ω	Ordering Number
10	4822 111 30349
22	5322 111 30396
33	4822 111 30067
56	5322 111 30074
82	4822 111 30352
100	4822 111 30324
220	4822 111 30327
330	4822 111 30328

Power Metal Film
Manufacturer: Philips
Type: PR52

P at 70°C: 2.5 W
 Tolerance: 5 %

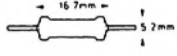

Ω	Ordering Number
68	5322 116 54396
100	5322 116 54392

Ceramic Potentiometers
Manufacturer: Philips
Type: Cermet Preset

Lin/Log: Lin
 P at 70°C: 0.5 W
 Tolerance: 20 %

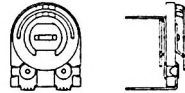

Ω	Ordering Number
10k	5322 100 10113

Lacquered Metal Film
Manufacturer: Philips
Type: MR25

P at 70°C: 0.4 W
 Tolerance: 1 %

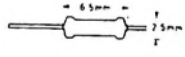

Ω	Ordering Number
1.21	5322 116 55603
1.47	5322 116 55604
2.15	5322 116 55415
56.2	5322 116 54446
82.5	5322 116 54462
147	5322 116 50766
178	5322 116 54492
196	5322 116 50676
332	5322 116 54513
383	5322 116 54518
464	5322 116 50536
562	5322 116 54009
1 k	5322 116 54549
1.87 k	5322 116 50728
1.96 k	5322 116 55605
2.15 k	5322 116 50767
3.01 k	5322 116 50524
3.32 k	5322 116 54005
4.42 k	5322 116 50556
6.81 k	5322 116 54012
7.5 k	5322 116 54608
10 k	5322 116 54619
13.3 k	5322 116 55276
15.4 k	5322 116 50479
21.5 k	5322 116 50451
46.4 k	5322 116 50557
90.9 k	5322 116 54694
100 k	5322 116 54696
332 k	5322 116 54731

Carbon Film
Manufacturer: Philips
Type: CR25

P at 70°C: 0.33 W
 Tolerance up to 1 M: 5 %
 Tolerance from 1.2 M: 10 %

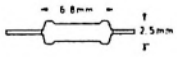

Ω	Ordering Number
1M	4822 110 63187
10M	4822 110 63214

NTC Thermistor
Manufacturer: Elcoma
Type: 2322 642 1

P at 55°C: 0.5 W
 Tolerance: 5 %



Ω	Ω	Ω	Ordering
at 25°C	at 0°C	at 50°C	Number
4.7 k	15 k	1.5 k	4822 116 30114

Power Metal Film
Manufacturer: Philips
Type: PR37

P at 70°C: 1.6 W
 Tolerance: 5 %

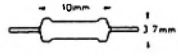

Ω	Ordering Number
100	4822 116 51098

Standard Networks
Manufacturer: Koa Denko
Type: RK 1/8 B

P at 70°C: $R_n \times 125 \text{ mW}$
 Tolerance: 10 %
 Max voltage: 200 V

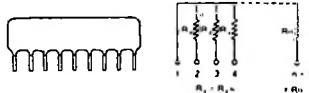

Ω	Length	Ordering Number
1kx6	19.5	5322 111 94015

capacitors capacitors

Aluminium Electrolytic
Manufacturer: Philips
Type 2222 030...033
Tolerance: $-10+50\%$ 

Capacitance, μF	Voltage, V	Ordering Number
2200	25	4822 124 20788

Ceramic Chip
Manufacturer: Philips
Type 2222 852

Voltage: 50 V



Capacitance, pF	Tolerance, %	Ordering Number
10000	20	5322 122 34098

Ceramic Disc
Manufacturer: Philips
Type: 2212 660

Rated ac voltage: 250 V

Tolerance: 20 %

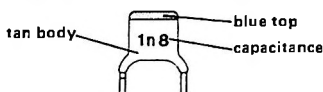

Capacitance, pF	Ordering Number
1000	4822 122 44019

Miniature Ceramic Plate
Manufacturer: Philips
Type: 2222 640
Voltage: 100 V
Tolerance: $-20+50\%$ 

Capacitance, pF	Ordering Number
10000	5322 122 34041

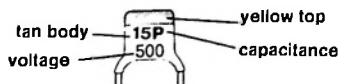
Miniature Ceramic Plate
Manufacturer: Philips
Type: 2222 655
Voltage: 500 V
Tolerance: 10%

Capacitance, pF	Ordering Number
1000	4822 122 31175

capacitors capacitors

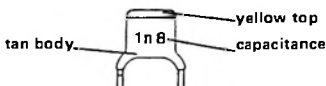
Miniature Ceramic Plate
Manufacturer: Philips
Type: 2222 630
Voltage: 100 V
Tolerance: 10 %

Capacitance, pF	Ordering Number
330	4822 122 31165
560	4822 122 30126
1000	4822 122 31175

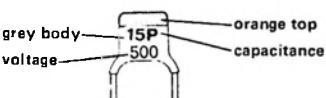
Miniature Ceramic Plate
Manufacturer: Philips
Type: 2222 650
Voltage: 500 V
Tolerance: 2 %

Capacitance, pF	Ordering Number
3.3	4822 122 31217

Film Dielectric Trimmers
Manufacturer: Philips
Type: 2222 809 090

Voltage: 300 V

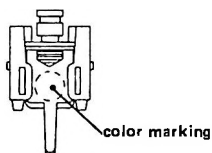

Capacitance, pF	Ordering Number	Colour Marking
2-9	5322 125 54024	White dot

Film Dielectric Trimmers
Manufacturer: Elcoma
Type: 2222 808

Voltage: 250 V

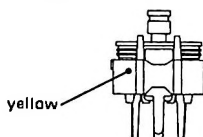

Capacitance, pF	Ordering Number	Colour Marking
5.5-65	4822 125 50017	Yellow

capacitors capacitors

Metallized Polyester and Polycarbonate Film
Manufacturer: Philips
Type: 2222 344

Tolerance: 10 %

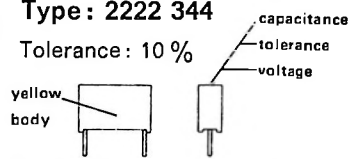

Capacitance, nF	Voltage, V	Ordering Number
4.7	630	5322 121 44225
10	400	5322 121 44291
22	250	5322 121 40308
100	100	5322 121 40323

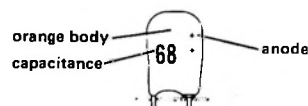
Solid Aluminium Electrolytic
Manufacturer: Philips
Type: 2222 122
Tolerance: $-10+50\%$ 

Capacitance, μF	Voltage, V	Ordering Number
1	25	5322 124 14075
2.2	16	4822 124 10204
6.8	25	5322 124 14081
10	6.3	5322 124 14066
15	6.3	4822 124 20941
15	16	5322 124 14036
68	6.3	5322 124 14079

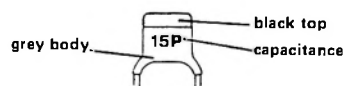
Miniature Ceramic Plate
Manufacturer: Philips
Type: 2222 638
Voltage: 100 V
Tolerance: 0.25 pF or 2 %

Capacitance, pF	Ordering Number
1.5	4822 122 30105
3.3	4822 122 31041
5.6	4822 122 31047
6.8	4822 122 31049
10	4822 122 31054
12	4822 122 31056
15	4822 122 31058
18	4822 122 31061
22	4822 122 31063
33	4822 122 31067
39	4822 122 31049

Transistors

Type	Ordering number
BD 204	4822 130 41043
BRF 90	5322 130 44179
BF 256A	5322 130 44418
BC 458B	4822 130 40937
BC 558B	5322 130 44197
2N 5770	5322 130 44435
2N 5771	5322 130 44845

Diodes

Type	Ordering number
BAT 43	5322 130 34969
BAV 10	5322 130 30594
BAW 62	5322 130 30613
BA 379	5322 130 34364
HSCH 1001	5322 130 34877
1N 4003	5322 130 30208
BZX 75C1V4	5322 130 34047
HP 5082-2835	5322 130 34283

Integrated circuits

Type	Ordering number
SAB 1009BP	5322 209 86202
SAB 1046P	5322 209 86199
SAA 1062	5322 209 86204
GZF 1201P	5322 209 84722
HEF 4737VP	5322 209 14511
CA 3140E	5322 209 86201
MC 7805CT	5322 209 84454
µA 78S40	5322 209 86513
µA 78L26AC	5322 209 86515
µC 8048	5322 209 14702
µC 10116P	5322 209 85798
LM 324	5322 209 86514
MC 10138P	5322 209 86203
MC 74LS03N	5322 209 85265
MC 74LS74N	5322 209 84986
MC 74LS393	4822 209 80447

IC holders

Description	Ordering number
3 pins	5322 265 64028
14 pins	5322 255 44082
16 pins	5322 255 44111
18 pins	5322 255 44133
28 pins	5322 255 44047
40 pins	5322 255 44217

Sockets and connectors

Item	Description	Ordering number
BU 1	BNC for LF input	5322 267 10004
BU 2	BNC for RF input	5322 267 10004
BU 3	BNC for Ext. std input	5322 267 10004
BU 4	Line voltage input	5322 265 30066
BU 6	2 pole for external battery jack	} see section 5 in this manual
BU 7	Battery jack for external battery	
BU 101	3 pole for display board	5322 265 34105
BU 101	10 pole for PM 9601	5322 267 54195
BU 101	3 pole for TCXO	5322 267 44111
BU 102	9 pole for display board	5322 265 64028
BU 103	5 pole for prescaler board	5322 265 44057
BU 104	10 pole for internal battery	5322 265 64028
BU 105	3 pole for TCXO	5322 265 34105
BU 106	3 pole for IC 112	5322 265 64028
BU 107	5 pole for mains trafo and external battery	5322 265 44057
BU 108	Miniature BNC for Ext. Std.	5322 267 34043
BU 201	3 pole for basic board	5322 267 44111
BU 202	9 pole for basic board	5322 267 54194
BU 203	2 x 17 pole for LCD	5322 267 54193
BU 204	2 x 17 pole for LCD	5322 267 54193
BU 205	Miniature BNC for LF input	5322 267 34043
BU 301	5 pole for basic board	5322 267 44112
BU 302	Miniature BNC for HF input	5322 267 34043

Switches

Item	Description	Ordering number
SK 101	Line	5322 276 14358
SK 102	Measurement time	5322 276 14388
SK 201	Sensitivity	5322 273 44017
DV 101	Jumper for Ext./Int. Std.	5322 263 64007

Miscellaneous

Item	Ordering number
Window	5322 459 44002
Display	5322 130 94021
Extension bar	5322 535 94648
Mains transformer	5322 146 14188
Crystal 10 MHz	5322 242 74163
Thermal fuse	4822 252 20007
1.6A fuse	4822 253 20022
Fuse holder	5322 256 34104

Inductances

Item	Ordering number
L 101	5322 158 10052
L 102	5322 158 10243
L 301	5322 158 10311
L 302	5322 157 34019
L 303	5322 158 10052

Knobs and cover for knobs

Item	Ordering number
Line knob	5322 414 26019
Measurement knob	5322 414 14011
Sensitivity knob	5322 414 34091
Cover for sensitivity knob	5322 414 74015

Feet

Item	Ordering number
Front	5322 462 44434
Rear	5322 462 44435

Cabinet

Item	Ordering number
Handle	5322 498 54101
Spring for handle	5322 492 64745
Housing	5322 447 94581

Textplates

Instrument	Ordering number
PM 6667	5322 455 94004
PM 6668	5322 455 94005

Coding system of failure reporting for quality assessment of T & M instruments

(excl. potentiometric recorders)

The information contents of the coded failure description is necessary for our computerized processing of quality data.

Since the reporting of repair and maintenance routines must be complete and exact, we give you an example of a correctly filled-out PHILIPS SERVICE Job sheet.

① Country	② Day Month Year	③ Typenumber /Version	④ Factory/Serial no.
3 2	1 5 0 4 7 5	0 P M 3 2 6 0 0 2	D O 0 0 7 8 3

CODED FAILURE DESCRIPTION

⑤ Nature of call	⑥ Location	⑦ Component/sequence no.	⑧ Category
<input type="checkbox"/> Installation		T S 0 6 0 7	5
<input type="checkbox"/> Pre sale repair		R 0 0 6 3 1	2
<input type="checkbox"/> Preventive maintenance	0 0 2 1	9 9 0 0 0 1	4
<input checked="" type="checkbox"/> Corrective maintenance			
<input type="checkbox"/> Other			

⑦ Job completed

⑧ Working time Hrs

Detailed description of the information to be entered in the various boxes:

- ① Country: 3 2 = Switzerland
- ② Day Month Year 1 5 0 4 7 5 = 15 April 1975
- ③ Type number/Version 0 P M 3 2 6 0 0 2 = Oscilloscope PM 3260, version 02 (in later oscilloscopes this number is placed in front of the serial no)
- ④ Factory/Serial number D O 0 0 7 8 3 = DO 783 These data are mentioned on the type plate of the instrument
- ⑤ Nature of call: Enter a cross in the relevant box
- ⑥ Coded failure description

Location

<input type="checkbox"/>	<input type="checkbox"/>	<input type="checkbox"/>	<input type="checkbox"/>
--------------------------	--------------------------	--------------------------	--------------------------

These four boxes are used to isolate the problem area. Write the code of the part in which the fault occurs, e.g. unit no or mechanical item no of this part (refer to "PARTS LISTS" in the manual).

Example: 0001 for Unit 1
000A for Unit A
0075 for item 75

If units are not numbered, do not fill in the four boxes; see Example Job sheet.

Component/sequence no.

<input type="checkbox"/>	<input type="checkbox"/>	<input type="checkbox"/>	<input type="checkbox"/>	<input type="checkbox"/>	<input type="checkbox"/>
--------------------------	--------------------------	--------------------------	--------------------------	--------------------------	--------------------------

These six boxes are intended to pinpoint the faulty component. A. Enter the component designation as used in the circuit diagram. If the designation is alpha-numeric, the letters must be written (starting from the left) in the two left-hand boxes and the figures must be written (in such a way that the last digit occupies the right-most box) in the four right-hand boxes. B. Parts not identified in the circuit diagram:

- 990000 Unknown/Not applicable
990001 Cabinet or rack (text plate, emblem, grip, rail, graticule, etc.)
990002 Knob (incl. dial knob, cap, etc.)
990003 Probe (only if attached to instrument)
990004 Leads and associated plugs
990005 Holder (valve, transistor, fuse, board, etc.)
990006 Complete unit (p.w. board, h.t. unit etc.)
990007 Accessory (only those without type number)
990008 Documentation (manual, supplement, etc.)
990009 Foreign object
990099 Miscellaneous

Category

<input type="checkbox"/>

- 0 Unknown, not applicable (fault not present, intermittent or disappeared)
1 Software error
2 Readjustment
3 Electrical repair (wiring, solder joint, etc.)
4 Mechanical repair (polishing, filing, re-machining, etc.)
5 Replacement (of transistor, resistor, etc.)
6 Cleaning and/or lubrication
7 Operator error
8 Missing items (on pre-sale test)
9 Environmental requirements are not met

- ⑦ Job completed: Enter a cross when the job has been completed.
- ⑧ Working time: Enter the total number of working hours spent in connection with the job (excluding travelling, waiting time, etc.), using the last box for tenths of hours.

1 2 = 1,2 working hours (1 h 12 min.)

Sales and service all over the world

- Alger:** Bureau de Liaison Philips,
13 Rue Med-El-Mansour Benkara (Ex Rue
Ferrando), El Biar, Alger, tel. 789336
- Argentina:** Philips Argentina S.A.,
Casilla Correo 3479, (Central), 1000 Buenos Aires;
tel. 70-7741 al 7749/70-2325/2905/6488
- Australia:** Philips Scientific & Industrial
Equipment Division, Centre Court,
25 - 27 Paul Street, P.O. Box 119,
North Ryde/NSW 2113; tel. 888-8222
- Bangla Desh:** Philips Bangla Desh Ltd.
P.O. Box 62; Ramna, Dacca; tel. 283332
- België/Belgique:** S.A. M.B.L.E.,
Philips Scientific and Industrial Equipment
Division;
80 Rue des Deux Gares, 1070 Bruxelles;
tel. 2 - 523.00.00
- Bolivia:** Industrias Bolivianas Philips S.A.
Cajón Postal 2964, La Paz;
tel.: 50029/55270/55604
- Brasil:** Philips Do Brasil Ltda;
Avenida 9 de Julho 5229; Caixa Postal 8681;
CEP 01407 - São Paulo (S.P.);
tel. 282-5722/282-1611
Service Centre:
Dépto. S&I - As. Técnica
Rua Navarro de Andrade, 152,
Caixa Postal 8147
CEP 05418 - São Paulo (S.P.);
tel. 280 7233
- Burundi:** Philips S.A.R.L.,
B.P. 900, Bujumbura; tel. 2082
- Canada:** Philips Test and Measuring Instruments Inc.;
6 Leswyn Road,
Toronto (Ontario) M6A1K2;
tel. (416) 789-7188
- Chile:** Philips Chilena S.A.;
Division Profesional, Avda. Santa Maria 0760;
Casilla 2687, Santiago de Chile; tel. 770038
- Colombia:** Industrias Philips de Columbia S.A.,
Calle 13 no. 51-03, Apartado Aereo 4282,
Bogotá; tel. 611877/600600
- Costa Rica:** Philips de Costa Rica Ltda.
Apartado Postal 4325, San José; tel. 210111
- Denmark:** Philips Elektronik-Systemer A/S
Aid. for Industri og Forskning; Strandlodvej 4,
P.O. Box 1919, 2300 København S;
tel. 01-57-2222; telex 31201
- Deutschland (Bundesrepublik):** Philips GmbH,
Unternehmensbereich Elektronik für
Wissenschaft und Industrie,
Postfach 310 320; 35 Kassel-Bettenhausen,
Miramstrasse 87; tel. 561-5011
- Ecuador:** Philips Ecuador S.A., Casilla 343,
Quito; tel. 239080
- Egypt:** Resident Delegate Office of Philips Industries,
P.O. Box 1687, Cairo; tel. 78457-57739
- Eire:** Philips Electrical (Ireland) Ltd.,
Newstead, Clonskeagh, Dublin 14; tel. 693355
- El Salvador:** Philips de El Salvador S.A.,
Apartado Postal 885, San Salvador;
tel. 217441/229066
- España:** Philips Ibérica S.A.E.,
Dpto Aparatos de Medida, Martínez Villergas 2,
Apartado 2065, Madrid 27;
tel. 404-2200/3200/4200
Service Centre:
Dpto Tco. de Instrumentación,
Calle de Albasanz 75, Madrid 17;
tel. 204-7100
- Ethiopia:** Philips Ethiopia (Priv. Ltd. Co.),
P.O.B. 2565;
Addis Ababa; tel. 448300
- Finland:** See Suomi
- France:** S.A. Philips Industrielle et Commerciale,
Division S&I
105 Rue de Paris, 93 002 Bobigny;
tel. 830-11-11
- Ghana:** Philips (Ghana) Ltd.,
P.O.B. M 14, Accra; tel. 66019
- Great Britain:** Pye Unicam Ltd., York Street,
Cambridge CB1-2PX; tel. (223) 358866
Service Centre:
Beddington Lane, Croydon, Surrey CR9-4EN;
tel. (684) 3670
- Greece:** See Hellas
- Guatemala:** Philips de Guatemala S.A.,
Apartado Postal 238, Ciudad de Guatemala,
Zona 9; tel. 320777
- Hellas:** Philips S.A. Hellénique,
54 Avenue Syngrou, P.O. Box 153,
Athens 403; tel. 9215311
- Hong Kong:** Philips Hong Kong Ltd.,
P.O.B. 2108, St. George's Building, 21st floor,
Hong Kong city; tel. 5-249246
Service Centre:
17 Yuk Yat Strat, 1st floor
Tai Chiap Factory Building
Tokwawan - Kowloon
Tel. 3-655221
- India:** Peico Electronics & Electricals Ltd.,
S&I Equipment, Shivsagar Estate,
Block "A", Dr. Annie Besant Road
P.O.B. 6598, Worli, Bombay 4000 18 (WBI);
tel. 370071/391431
- Indonesia:** P.T. Philips Development Corporation
Jalan Let. Jen. M.T. Kav. 17,
P.O.B. 2287, Jakarta-Selatan; tel. 583831/32
- Iran:** Philips Iran Ltd., P.O.B. 1297, Teheran;
tel. 372081/5
- Iraq:** Philips Iraq W.L.L., Munir Abbas Building,
4th floor; South Gate, P.O. box 5749, Baghdad;
tel. 80409/98844
- Island:** Heimilsteaki SF, Sættún 8, Reykjavík;
tel. 24000
- Islas Canarias:** Philips Ibérica S.A.E.,
Triana 132, Las Palmas; Casilla 39-41,
Santa Cruz de Tenerife
- Italia:** Philips S.p.A., Sezione S&I/T&M;
Viale Elvezio 2, 20052 Monza; tel. 36351,
telex Mi 35290
- Japan:** See Nippon
- Kenya:** Philips (Kenya) Ltd., P.O.B. 30554,
Nairobi; tel. 557999
- Kuwait:** Delegate Office of Philips Industries,
P.O. Box 3801, Kuwait; tel. 428678
- Malaysia:** Philips Malaysia Sdn Bhd.,
P.O. Box 2163, Petaling Jaya, Kuala Lumpur;
Selangor, W. Malaysia; tel. 774411
- México:** Philips Mexicana S.A. de C.V.,
Div. Científico Industrial, Durango 167,
Apartado Postal 24-328, México 7 (D.F.);
tel. 525 15 40
- Morocco:** S.A.M.T.E.L., 2 Rue de Bapaume,
Casablanca; tel. 243050-243052
- Nederland:** Philips Nederland B.V.,
Hooftgroep PPS, Boschdijk 525, Gebouw VB,
5600 VB Eindhoven; tel. 793333
- Ned. Antillen:** Philips Antillana N.V.,
Postbus 523, Willemstad; Curaçao;
tel. 37575-35464
- New Zealand:** Philips Electrical Industries of N.Z. Ltd.,
Scientific and Industrial Equipment Division;
Wakefield Street 181-195,
P.O.B. 2097, Wellington C1; tel. 859 859
- Nigeria:** Associated Electronic Products (Nigeria) Ltd.,
6 Ijora Causeway, P.O.B. 1921, Lagos; tel. 845414/7
- Nippon:** Nihon Philips Corporation,
Shuwa Shinagawa Building,
26-33 Takanawa 3 - Chome, Minato-Ku,
P.O. Box 13; Tokyo 108; tel. (03) 448-5574/5511
- Norge:** Norsk A.S. Philips,
Industri og Forskning, Essendrops gate 5,
Postboks 5040, Oslo 3; tel. 463890
Service Centre:
Postboks 1 Manglerud, Oslo 6; tel. 294010
- Österreich:** Oesterreichische Philips Industrie GmbH,
Abteilung Industrie Elektronik,
Breitenfurterstrasse 219, A-1230 Wien;
tel. (222) 841611/15
- Pakistan:** Philips Electrical Co. of Pakistan Ltd.,
El-Markaz, M.A. Jinnah Road, P.O.B. 7101,
Karachi 3; tel. 70071
- Paraguay:** Philips del Paraguay S.A.,
Casilla de Correo 605, Asunción;
tel. 48045/46919
- Perú:** Philips Peruana S.A.,
Av. Alfonso Ugarte 1268
Apartado Aereo 1841, Lima 100; tel. 326070
- Philippines:** Philips Industrial Development Inc.,
2246 Pasong Tamo, P.O.B. 911,
Makati Rizal; tel. 868951/868959
- Portugal:** Philips Portuguesa S.A.R.L.,
Av. Eng. Duarte Pacheco 6, Apartado 1331, Lisboa;
tel. 683121/9
Service Centre:
Oureta, Serviços Técnicos Profissionais; tel. 2180071
2795 Linda-a-Velha
- Saudi Arabia:** Messrs. A. Rajab and A. Siltalah,
P.O. Box 203, Jeddah - Saudi Arabia; tel. 27392/5.
- Schweiz-Suisse-Svizzera:** Philips A.G.,
Allmendstrasse 140, Postfach, CH-8027 Zürich;
tel. 01-432211/432629
- Singapore:** Philips Singapore Private Ltd.,
P.O. Box 340, Toa Payoh Central Post Office;
Singapore 12; tel. 538811
- South Africa:** South African Philips (Pty) Ltd.,
2 Herb Street, New Doornfontein, P.O.B. 7703,
Johannesburg 2000; tel. 614-0411
- South-Korea:** Philips Electronics (Korea) Ltd.,
P.O. Box 3680, Seoul; tel. 794 4202
- Suomi:** Oy Philips Ab.,
Kaivokatu 8,
P.O. Box 10255,
00101 Helsinki 10; tel. 17271
- Sverige:** Svenska A.B. Philips,
Philips Industrietelefonik, Lidingsövägen 50,
Fack, S11584 Stockholm; tel. 635000
- Syria:** Philips Moven-Orient S.A., Rue Fardost 79,
Immeuble Kassas and Sadate, B.P. 2442, Damas;
tel. 118605-221650
- Taiwan:** Philips Taiwan Ltd.,
San Min Building, P.O. Box 22978, Taipei;
tel. 5713231
- Tanzania:** Philips (Tanzania) Ltd.,
Box 20104, Dar es Salaam; tel. 29571/4
- Thailand:** Philips Electrical Co. of Thailand Ltd.,
283 Silom Road, P.O. Box 961, Bangkok;
tel. 233-6330
- Tunisia:** S.T.I.E.T., 32 bis, Rue Ben Ghedhahem,
Tunis; tel. 244268
- Türkiye:** Türk Philips Ticaret A.S.,
Posta Kutusu 504, Beyoglu,
Istanbul 1; tel. 435910
- Uruguay:** Industrias Philips del Uruguay S.A.,
Avenida Uruguay 1287, Casilla de Correo 294,
Montevideo; tel. 915641/44
- U.S.A.:** Philips Test and Measuring Instruments Inc.,
85, Mc Kee Drive, Mahwah, New Jersey 07430;
tel. (201) 529-3800
- Venezuela:** Industrias Venezolanas Philips S.A.,
Apartado Aereo 1167, Caracas 107;
tel. 2393811/353533
- Zaire:** Philips S.Z.R.L., B.P. 1798, Kinshasa;
tel. 31208
- Zambia:** Philips Electrical Zambia Ltd.,
Professional Equipment Division, P.O.B. 553;
Kitwe; tel. 25267/78
- For information on change of address:
N.V. Philips' Gloeilampenfabrieken
Test and Measuring Instruments Dept.
Eindhoven - The Netherlands
- For countries not listed:
N.V. Philips S&I Export Dept.
Test and Measuring Instruments Dept.
Eindhoven - The Netherlands

Standard symbols for logic elements

Circuit	I.E.C.	DIN norm 40700	American standard	Boolean function
AND				$X = AB$
OR				$X = A + B$
NAND				$X = \overline{AB}$
NOR				$X = \overline{A + B}$
NAND with one inverting input				$X = \overline{A}B$
NOR with one inverting input				$X = \overline{\overline{A} + B}$
INHIBIT GATE				$X = (A + B)\overline{C}$
EXCLUSIVE OR				$X = A\overline{B} + \overline{A}B$
COMPARATOR				$X = AB + \overline{A}\overline{B}$
Distributed AND				
Distributed OR				
DELAY				
FLIP-FLOP				