



B R O A D C A S T
TRANSMISSION
LINE

E Q U I P M E N T
for
TELEVISION

VHF COAXIAL LINE & FITTINGS

UHF COAXIAL LINE & FITTINGS

LINE ACCESSORIES

DIRECTIONAL COUPLERS

GASSING EQUIPMENT

POWER SWITCHING

BROADCAST TRANSMISSION LINE EQUIPMENT CATALOG

(Second Edition)

PRICE \$1.00



RADIO CORPORATION OF AMERICA

Broadcast & Television Equipment • Camden, N. J.

Page

Universal Coaxial Line 5

VHF Coaxial Line 25

Line Accessories 41

Power Switching 57

Directional Couplers 60

Quick Reference Data 62

Index 63

ABOUT THIS CATALOG

This Catalog is devoted solely to information on RCA Television Transmission Line equipment designed especially for television station and closed circuit use. Other RCA Broadcast Equipment Catalogs contain similar information on TV camera, film, terminal, audio and test equipments, AM, FM and TV transmitters and antennas.

The information contained in this catalog is intended to serve as a buying guide for the users of this type of equipment. In the belief that broadcast engineers want facts, rather than generalities, the content has purposely been kept brief and factual. Readers who desire more information or individual bulletins on particular equipment items are invited to write to the RCA Broadcast Representative in the RCA Regional Office nearest them (see opposite page).

OTHER RCA TECHNICAL PRODUCTS

The RCA equipment described in this catalog is specifically designed for broadcast station and closed circuit use. In similar manner RCA builds electronic equipment for many other industries. These include: two-way radio and microwave radio communication equipment; a complete line of equipment for theatres; optical and magnetic film recording equipment; sound systems of all types; 16mm projectors and magnetic recorders; high-fidelity components for home music systems; industrial inspection equipment; scientific equipment, such as the electron microscope; industrial television systems; intercoms; tape recorders; TV Eye; Antenaplex systems; and many types of custom-built equipment for industry and the military services. Information, and catalogs or bulletins, describing these may be obtained from RCA Regional Offices.

HOW TO ORDER

The RCA Television Transmission Line Equipment shown in this catalog is sold directly through RCA Broadcast Representatives, who are familiar with broadcast equipment and related problems. One or more of these RCA Repre-

sentatives are located in each of the RCA Regional Offices listed below. Orders for equipment shown in this catalog, or requests for additional information, should be directed to the nearest one of these offices.

PRICES

The prices of the various equipment units shown in this catalog are given in a separate price list. Prices are listed in the order in which they are shown in the catalog. To determine the price of any equipment first note the page

on which it is shown in the catalog, then consult the price list in accordance with this page number. Equipments are identified by type and MI (Master Item) numbers which are used to identify apparatus on invoices and packing slips.

YOU CAN LOCATE YOUR NEAREST RCA REPRESENTATIVE FROM THIS LIST

REGIONAL OFFICES

Front and Cooper Streets
CAMDEN 2, NEW JERSEY
Woodlawn 3-8000



36 West 49th Street
NEW YORK 20, NEW YORK
Judson 6-3800



7901 Freeway #183
DALLAS 35, TEXAS
Fleetwood 2-3911



1600 Keith Building
CLEVELAND 15, OHIO
Cherry 1-3450

200 Berkeley Street
BOSTON 16, MASSACHUSETTS
Hubbard 2-1700



1121 Rhodes-Haverty Building
134 Peachtree Street, N.W.
ATLANTA 3, GEORGIA
Jackson 4-7703



1006 Grand Avenue
KANSAS CITY 6, MISSOURI
Harrison 1-6480



1560 North Vine Street
HOLLYWOOD 28, CALIFORNIA
Hollywood 9-2154

420 Taylor Street
SAN FRANCISCO 2, CALIFORNIA
Ordway 3-8027



1186 Merchandise Mart Plaza
CHICAGO 54, ILLINOIS
Delaware 7-0700



1625 K Street, N.W.
WASHINGTON 6, D. C.
District 7-1260



2250 1st Avenue, South
SEATTLE 4, WASHINGTON
Main 8350

UNIVERSAL COAXIAL TRANSMISSION LINE

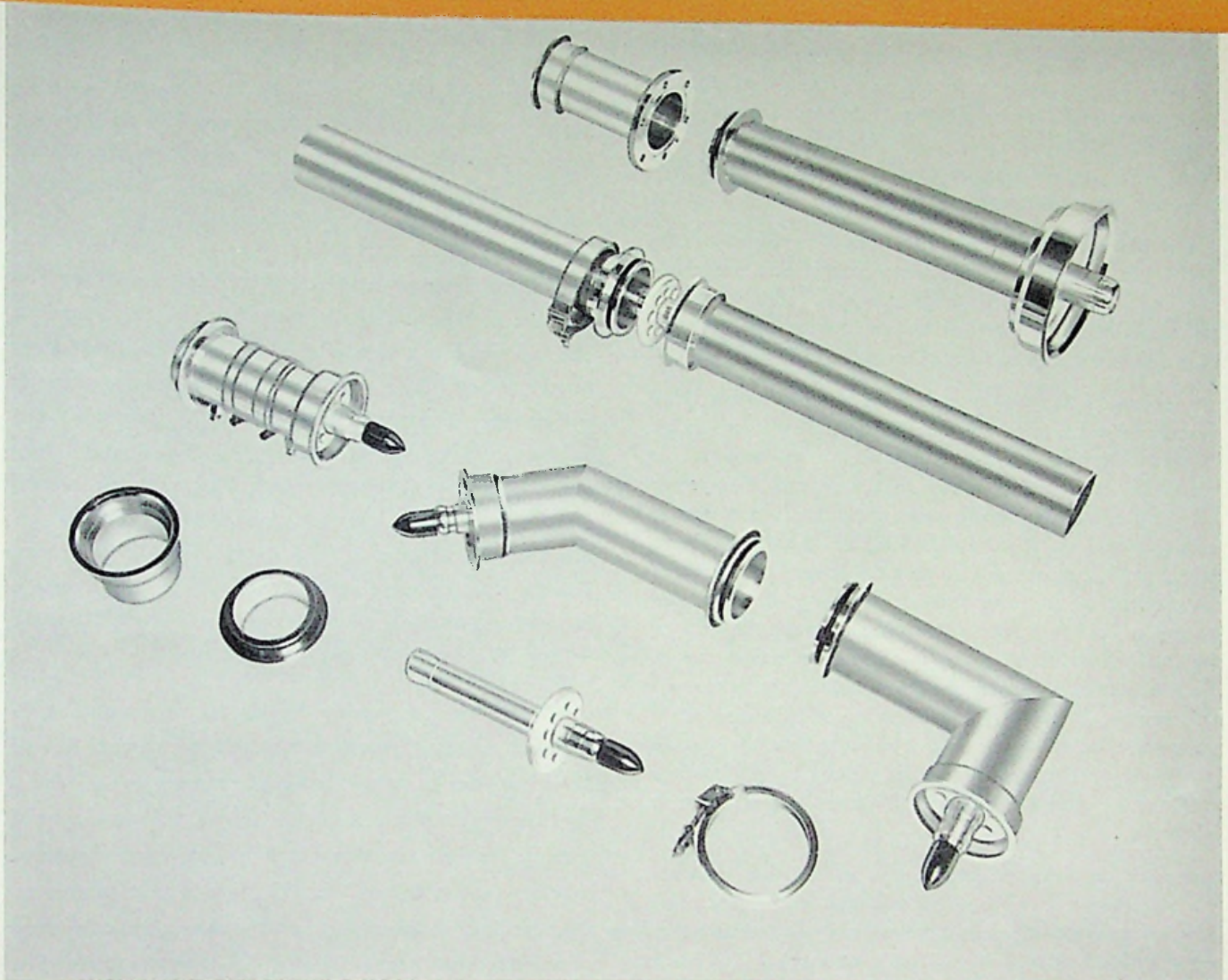

FEATURES

- Maximum stability provided by low-loss Teflon dielectric
- Minimum attenuation—maximum efficiency—low standing wave ratio
- Special Teflon insulators permit the line to be cut at any reasonable point along its length
- New quick connect flange
- Positive contact and positive alignment—no centering pins required
- Excellent power handling capability
- Complete line of fittings and accessories for installation versatility

USES

RCA's Universal Coaxial Transmission Line is a high efficiency Teflon insulated coaxial cable designed to transfer r-f energy from a source to a load in the most efficient manner. To provide a wide choice of desired efficiencies and power handling capabilities it is made available in three sizes: $3\frac{1}{8}$ "—50 ohm, $6\frac{1}{8}$ "—75 ohm, and $9\frac{3}{8}$ "—75 ohm. This type line can be used for both VHF and UHF television applications.

Universal transmission line is available in standard lengths of 20 feet, and also in $19\frac{1}{2}$ foot sections for those channels requiring the shorter length. Special Teflon insulators allow the universal line to be cut at any reasonable point along its length when installation plans demand.

The choice of the transmission lines used to connect the visual and aural transmitters to the filterplexers or bridge diplexer and the filterplexer output to the antenna is based on both the required efficiency and the power handling capability. A line size should be chosen having efficiency which will permit the desired effective radiated power, with some reserve, so that the transmitter need not be used at the extreme limit of its rating. A large size having a very low attenuation may increase the cost of the installation not only because of the increased cost of the line, but also because the windload on the tower will be increased by the larger projected area with a resulting increase in the tower cost. The line layout should also be made with a minimum number of elbows to both reduce cost and to keep the number of connections down to a minimum.

Pressurization must be used in the line so that moisture will not enter. It is necessary to maintain only a very small pressure to keep the line interior clean and dry. Either dry nitrogen, or dehydrated air may be used. Dry nitrogen is recommended for UHF line installations. The mating flanges are kept pressure-tight through the use of "O" rings.

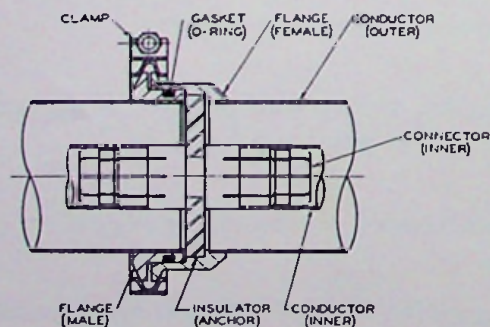

Cut-away drawing showing flanged connector assembly of Transmission Line.

DESCRIPTION

RCA's Universal Coaxial Transmission Line employs conductors which are made of high-conductivity, hard-drawn copper tubing. It has the inherent advantages of "flat" characteristic impedance of 50 or 75 ohms across a wide range of frequencies. This is made possible by development of a special Teflon undercut support insulator having a characteristic impedance equal to the air dielectric portion of the line over the useful operating range.

The Teflon insulator is "Electrically Transparent" and introduces no discontinuity or "bump" at the support points. This transparent characteristic avoids a standing wave pattern between insulators; consequently the line may be cut at any reasonable point along its length without changing operating impedance. The revolutionary construction of special undercut Teflon support and anchor insulators contributes many factors assuring efficiency of the line. Attenuation is held to an absolute minimum. Voltage standing wave ratio is extremely low. The power-handling capability is excellent over the UHF or VHF band as may be seen in the power rating curves.

Universal Line is extremely flexible for any type run. It comes in straight flanged sections with a complete line of fittings. All flange connections are inherently swivel adapting it to any rotational angle. Quick and positive assembly is made through use of a Marman type clamp requiring only one bolt to tighten. The "O" ring is held captive on the male flange, preventing damage due to mis-alignment or dropping during assembly. The "O" ring is held between cylindrical surfaces and removed from the electrical contact surfaces so that a damaged ring cannot prevent electrical contact. This new male-female quick connect flange provides positive alignment by coaxial cylindrical surfaces which eliminates centering pins. The lines make use of an anchor insulator bullet assembly which supports the inner conductor in place on vertical runs. The bullet is made in one piece and uses spring expanders to make positive electrical contact with the inner conductor.

A complete line of fittings and accessories is available from RCA as a single source to provide "matched" equipment for any desired installation. Line pressurizing equipment and tower mounting accessories are also available.

OUTLINE DRAWINGS . . . 3 1/8" UNIVERSAL LINE

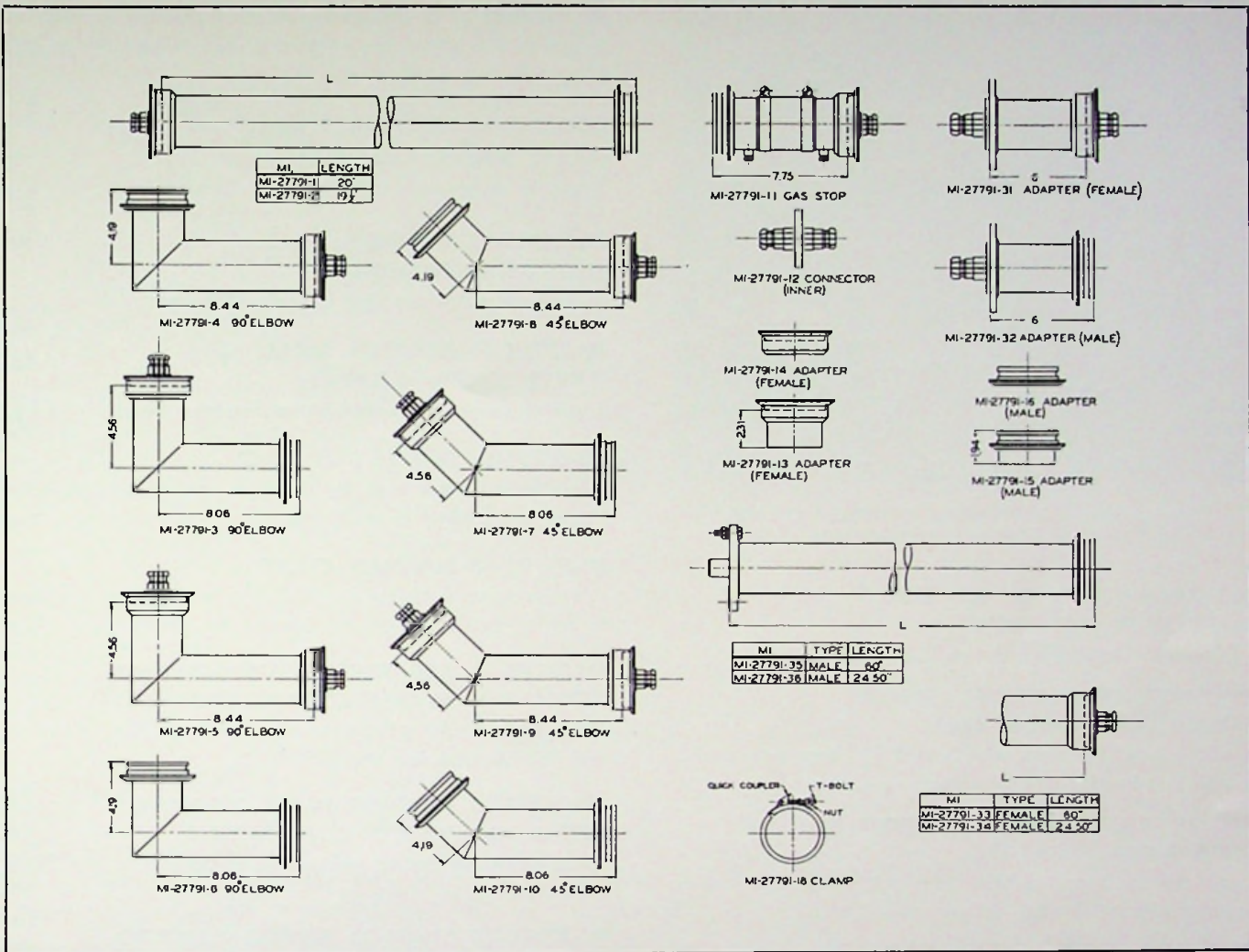

3 1/8" UNIVERSAL LINE

MI-27791-1 TRANSMISSION LINE

This line is supplied in 20 foot length with flanges silver-soldered to ends. The outer conductor is 3.125" O.D. with an inner conductor of 1.315" O.D. centered by special low loss Teflon insulators. The line is designed to allow removal of the inner conductor for inspection. It is supplied with a single anchor insulator connector (MI-27791-12), one "O" ring (MI-27791-17) and one Marman Clamp (MI-27791-18).

MI-27791-2 TRANSMISSION LINE

Same as MI-27791-1 except 19 1/2 feet in length. (See table for channels requiring 19 1/2 foot sections.)

MI-27791-3 COUPLING, 90° ELBOW (FEMALE OUTER, SHORT LEG)

A 90° elbow, supplied with one "O" ring, one anchor insulator connector and one Marman clamp.

MI-27791-4 COUPLING, 90° ELBOW (MALE OUTER, SHORT LEG)

A 90° elbow supplied with one "O" ring, one anchor insulator connector and one Marman clamp.

MI-27791-5 COUPLING, 90° ELBOW (FEMALE OUTER, BOTH LEGS)

A 90° elbow supplied with two anchor insulator connectors, and two Marman clamps.

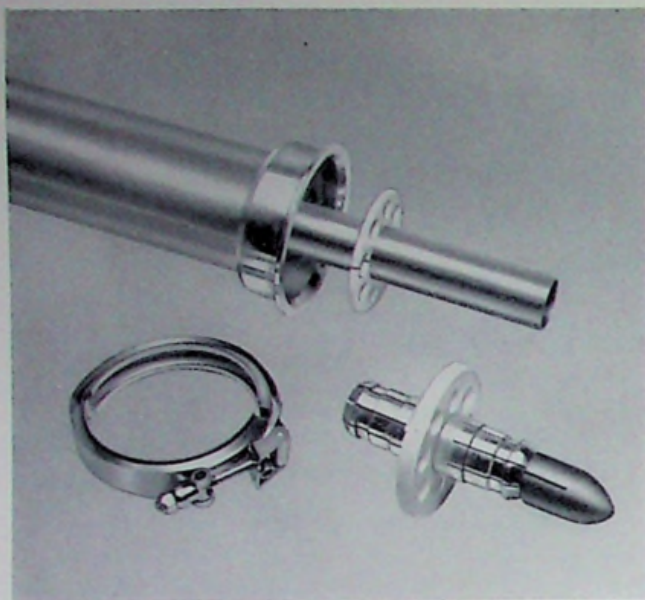

Close up view of RCA Universal Transmission Line with Marman Clamp and Inner Connector

**MI-27791-6 COUPLING, 90° ELBOW
(MALE OUTER, BOTH LEGS)**

A 90° elbow supplied with two "O" rings.

**MI-27791-7 COUPLING, 45° ELBOW
(FEMALE OUTER, SHORT LEG)**

A 45° elbow supplied with one "O" ring, one anchor insulator connector and one Marman clamp.

**MI-27791-8 COUPLING, 45° ELBOW
(MALE OUTER, SHORT LEG)**

A 45° elbow supplied with one "O" ring, one anchor insulator connector and one Marman clamp.

**MI-27791-9 COUPLING, 45° ELBOW
(FEMALE OUTER, BOTH LEGS)**

A 45° elbow supplied with two anchor insulator connectors and two Marman clamps.

**MI-27791-10 COUPLING, 45° ELBOW
(MALE OUTER, BOTH LEGS)**

A 45° elbow supplied with two "O" rings.

MI-27791-11 GAS STOP

A stop designed for insertion between two flanged sections of line to seal a gas section from an ungas section. The stop is supplied with two 1/8" pipe plugs at the gas connections, one "O" ring, one anchor insulator connector, and one Marman clamp. The gas stop can be pressurized from either side.

MI-27791-12 CONNECTOR, INNER

This anchor insulator bullet assembly consists of a Teflon insulator and two spring expanders to make positive electrical contact with the inner conductor.

**MI-27791-13 ADAPTOR, FEMALE
(SOFT SOLDER ASSEMBLY)**

An adaptor for mechanically adapting the end of field-cut length of line where the original silver soldered flange has been removed in shortening the line.

**MI-27791-14 ADAPTOR, FEMALE
(SILVER SOLDER ASSEMBLY)**

Same as above only installed with silver solder.

**MI-27791-15 ADAPTOR, MALE
(SOFT SOLDER ASSEMBLY)**

A male adaptor installed by soft-soldering.

**MI-27791-16 ADAPTOR, MALE
(SILVER SOLDER ASSEMBLY)**

Same as above, only installed with silver solder.

MI-27791-17 GASKET ("O" RING)

A synthetic rubber ring for 3/8" line used to seal the gas in the pressurized coaxial line.

MI-27791-18 MARMAN CLAMP

A stainless steel clamp for 3/8" line which uses one bolt to firmly secure sections of coaxial line or fittings.

**MI-27791-31 ADAPTOR (FEMALE OUTER TO
RETMA 3/8"—50 OHM COAXIAL LINE)**

This female fitting adapts the new Universal line to standard RETMA type line (MI-19089).

**MI-27791-32 ADAPTOR (MALE OUTER TO
RETMA 3/8"—50 OHM COAXIAL LINE)**

Same as above except male outer to connect to MI-19089 type line.

**MI-27791-33 ADAPTOR (FEMALE OUTER TO
3/8"—51.5 OHM COAXIAL LINE)**

This special type female fitting adapts the new Universal line to special lines MI-19113 or MI-19313 for use on channels 2 through 6 only. Specify channel when ordering.

**MI-27791-34 ADAPTOR (FEMALE OUTER TO
3/8"—51.5 OHM COAXIAL LINE)**

Same as above only for use on channels 7 through 13 only. Specify channel when ordering.

**MI-27791-35 ADAPTOR (MALE OUTER TO
3/8"—51.5 OHM COAXIAL LINE)**

A male outer fitting to adapt the new Universal line to special lines MI-19113 or MI-19313 for use on channels 2 through 6 only. Specify channel when ordering.

**MI-27791-36 ADAPTOR (MALE OUTER TO
3/8"—51.5 OHM COAXIAL LINE)**

Same as above only for use on channels 7 through 13 only. Specify channel when ordering.

3 1/8" TRANSMISSION LINE TOWER LAYOUT

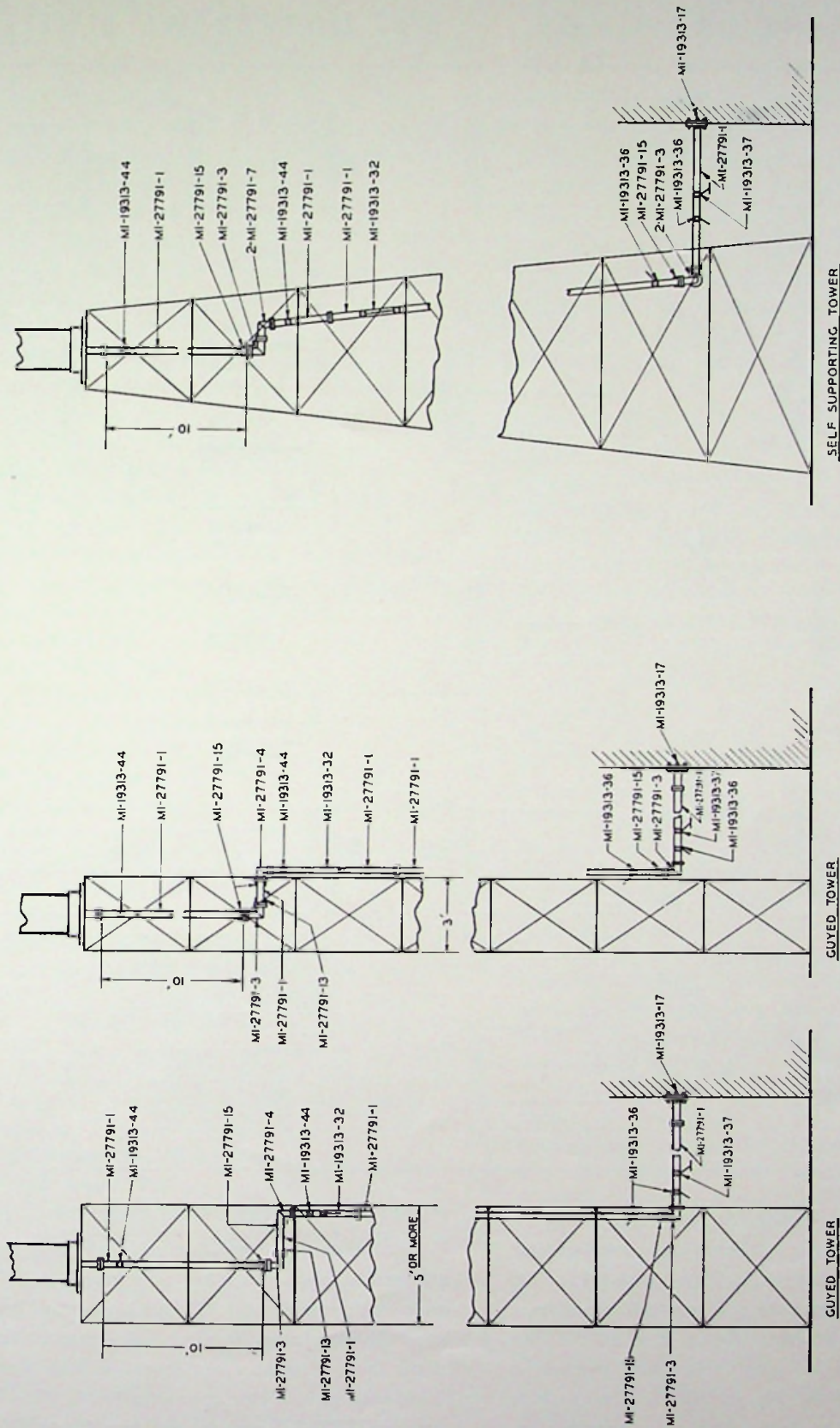

LEGEND

- 27791-1 3 1/8" T/L 20' Long
- 27791-3 3 1/8" 90° Miter Elbow, Female Outer Short Leg
- 27791-4 3 1/8" 90° Miter Elbow, Male Outer Short Leg
- 27791-7 3 1/8" 45° Miter Elbow, Female Outer Short Leg
- 19313-13 Adaptor, Female, Soft Solder
- 27791-15 Adaptor, Male, Soft Solder
- 19313-32 3 1/8" Spring Hanger (Direct Mounting)
- 19313-44 3 1/8" Fixed Hanger (Direct Mounting)
- 19313-17 3 1/8" Horizontal Anchor (Single)
- 19313-36 Lateral Brace
- 19313-37 3 1/8" Swivel Hanger (Single)

OUTLINE DRAWINGS . . . 6 1/8" UNIVERSAL LINE

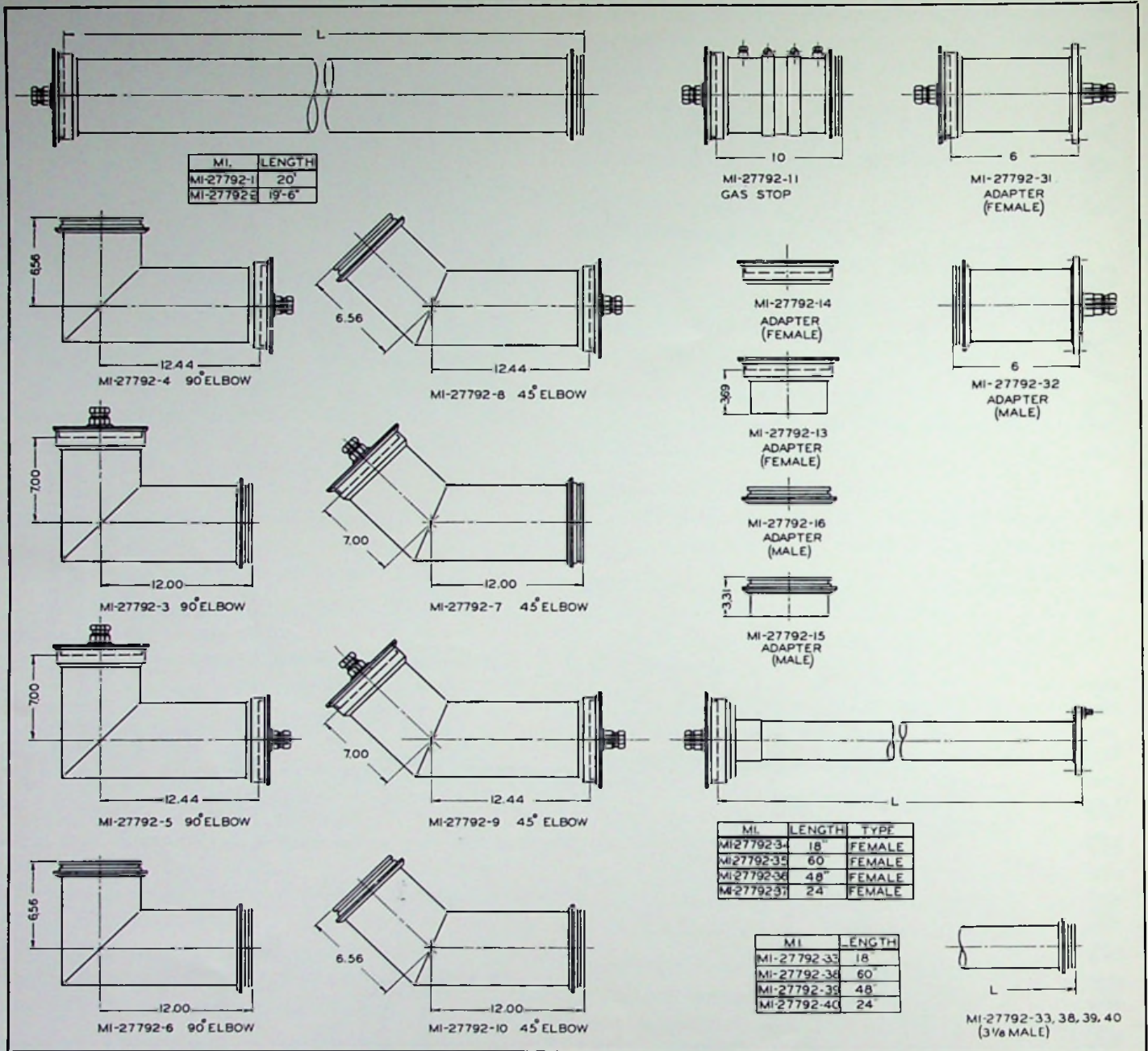

6 1/8" UNIVERSAL LINE

The basic design of RCA 6 1/8" Universal Transmission Line, MI-27792, is the same as the 3 1/8" line (MI-27791). The main differences are size and the characteristic impedance. The size and characteristic impedance of 6 1/8"—75 ohm line contribute to very low attenuation and provide a higher power-handling capability. Included in this brochure are comparative curves to show electrical characteristics.

MI-27792-1 TRANSMISSION LINE

This line is supplied in 20-foot lengths with flanges silver-soldered to ends. The outer conductor is 6.125" O.D. with an inner conductor of 1.711" O.D. centered by special low loss Teflon insulators. The line is designed to allow removal of the inner conductor for inspection. It is supplied with a single anchor insulator connector (MI-27992-12), one "O" ring (MI-27792-17) and one Marman Clamp (MI-27792-18).

MI-27792-2 TRANSMISSION LINE

Same as MI-27792-1 except supplied in 19½-foot length. (See table for channels requiring 19½-foot sections.)

MI-27792-3 COUPLING, 90° ELBOW (FEMALE OUTER, SHORT LEG)

A 90° elbow fitting supplied with one "O" ring, one anchor insulator connector and one Marman clamp.

MI-27792-4 COUPLING, 90° ELBOW (MALE OUTER, SHORT LEG)

A 90° elbow fitting supplied with one "O" ring, one anchor insulator connector and one Marman clamp.

MI-27792-5 COUPLING, 90° ELBOW (FEMALE OUTER, BOTH LEGS)

A 90° elbow fitting supplied with two anchor insulator connectors, and two Marman clamps.

MI-27792-6 COUPLING, 90° ELBOW (MALE OUTER, BOTH LEGS)

A 90° elbow fitting supplied with two "O" rings.

MI-27792-7 COUPLING, 45° ELBOW (FEMALE OUTER, SHORT LEG)

A 45° angle fitting supplied with one "O" ring, one anchor insulator connector and one Marman clamp.

MI-27792-8 COUPLING, 45° ELBOW (MALE OUTER, SHORT LEG)

A 45° angle fitting supplied with one "O" ring, one anchor insulator connector and one Marman clamp.

MI-27792-9 COUPLING, 45° ELBOW (FEMALE OUTER, BOTH LEGS)

A 45° angle fitting supplied with two anchor insulator connectors and two Marman clamps.

MI-27792-10 COUPLING, 45° ELBOW (MALE OUTER, BOTH LEGS)

A 45° angle fitting supplied with two "O" rings.

MI-27792-11 GAS STOP

Similar to 3⅜" gas stop, MI-27791-11 for use with 6⅛" line.

MI-27792-12 CONNECTOR, INNER

Anchor insulator bullet assembly for use with 6⅛" O.D. coaxial line consisting of a Teflon insulator with two spring expanders to make positive electrical contact with the inner conductor.

MI-27792-13 ADAPTOR, FEMALE (SOFT SOLDER ASSEMBLY)

An adaptor for mechanically adapting the end of field-cut length of 6⅛" line where the original silver-soldered flange has been removed in shortening the line.

MI-27792-14 ADAPTOR, FEMALE (SILVER SOLDER ASSEMBLY)

Same as above only installed with silver solder.

MI-27792-15 ADAPTOR, MALE (SOFT SOLDER ASSEMBLY)

A male adaptor installed by soft-soldering.

MI-27792-16 ADAPTOR, MALE (SILVER SOLDER ASSEMBLY)

Same as above, only installed with silver solder.

MI-27792-17 GASKET ("O" RING)

A long-life synthetic rubber gasket for use between flanges to make flanged joints pressure-tight.

MI-27792-18 MARMAN CLAMP

Similar to MI-27791-18 except larger for use with 6⅛" O.D. Universal Transmission line.

MI-27792-31 ADAPTOR (FEMALE OUTER TO RETMA 6⅛"—75 OHM COAXIAL LINE)

This female fitting adapts the new Universal 6⅛" line to standard RETMA type 6⅛" O.D. coaxial transmission line (MI-19387).

MI-27792-32 ADAPTOR (MALE OUTER TO RETMA 6⅛"—75 OHM COAXIAL LINE)

Similar to above only with male outer adaptor.

MI-27792-33 ADAPTOR (FEMALE OUTER TO UNIVERSAL 3⅜"—50 OHM COAXIAL WITH MALE OUTER)

This female fitting adapts the new Universal 6⅛" line to the 3⅜" Universal line, MI-27791, for channels 14 to 83.

MI-27792-34 ADAPTOR (FEMALE OUTER TO RETMA 3⅜"—50 OHM COAXIAL LINE)

A similar female fitting to adapt the 6⅛" Universal to 3⅜" O.D. standard line, for channels 14 to 83.

MI-27792-35 ADAPTOR (FEMALE OUTER TO 3⅜"—51.5 COAXIAL LINE)

A similar female fitting to adapt the 6⅛" Universal line to 3⅜"—51.5 ohm coaxial line, MI-19113 and MI-19313, for channels 2 and 3.

MI-27792-36 ADAPTOR (FEMALE OUTER TO 3⅜"—51.5 OHM COAXIAL LINE)

A similar female fitting to adapt the 6⅛" Universal line to 3⅜"—51.5 ohm coaxial line, MI-19113 and 19313, for channels 4, 5 and 6.

MI-27792-37 ADAPTOR (FEMALE OUTER TO 3⅜"—51.5 OHM COAXIAL LINE)

A similar female fitting to adapt the 6⅛" Universal line to 3⅜"—51.5 ohm coaxial line, MI-19113 and 19313, for channels 7 through 13.

MI-27792-38 ADAPTOR (FEMALE TO UNIVERSAL 3⅜"—50 OHM COAXIAL MALE, MI-27791)

A female fitting to adapt the 6⅛" Universal line to 3⅜" Universal line for channels 2 and 3 only.

MI-27792-39 ADAPTOR (FEMALE TO UNIVERSAL 3⅜"—50 OHM COAXIAL MALE, MI-27791)

Similar to above only for use on channels 4-6 only.

MI-27792-40 ADAPTOR (FEMALE TO UNIVERSAL 3⅜"—50 OHM COAXIAL MALE, MI-27791)

Similar to MI-27792-38 except specified for channels 7-13 inclusive.

6 1/8" TRANSMISSION LINE TOWER LAYOUT

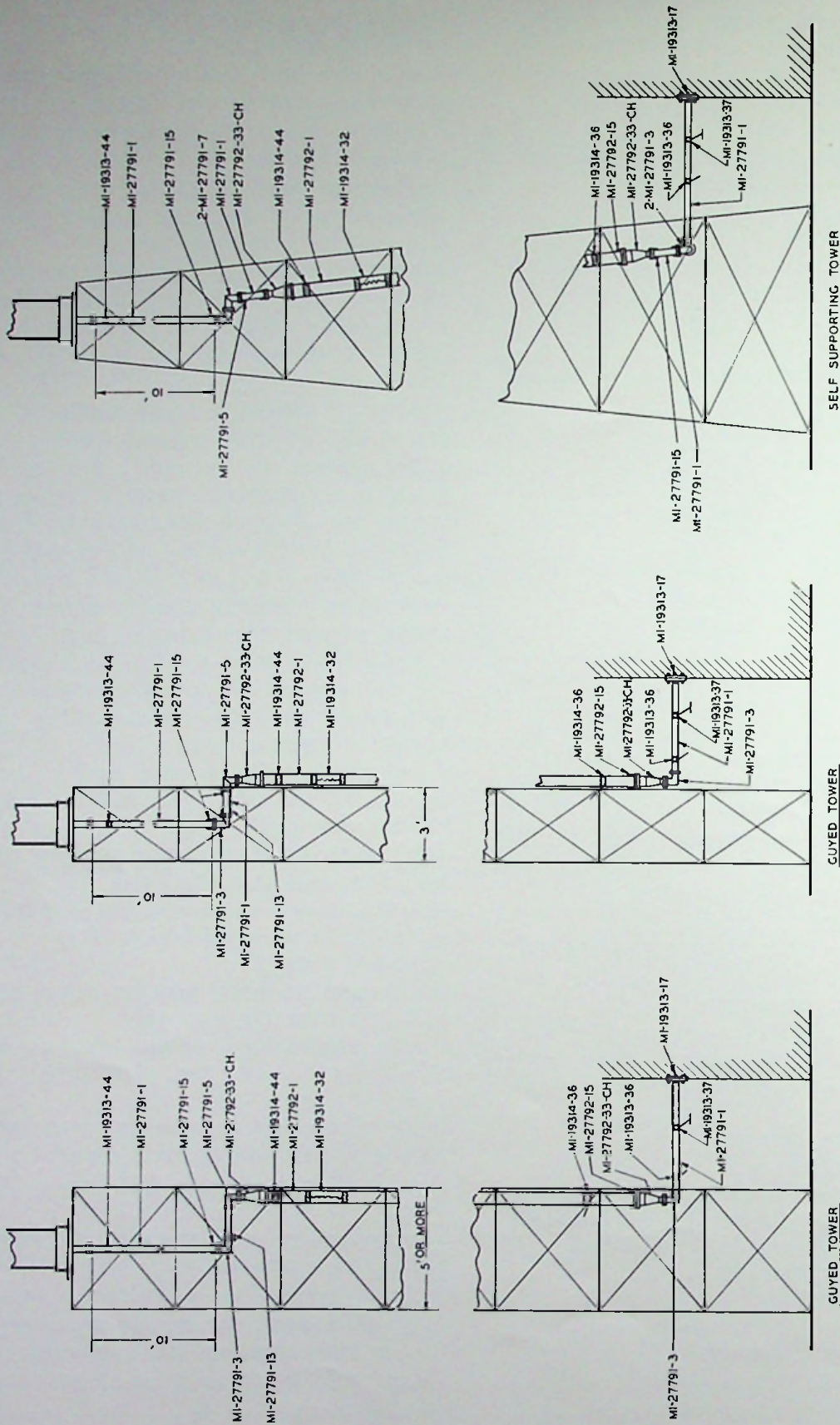

LEGEND

- 27791-1 3 1/8" T/L 20' Long (50 Ohm)
- 27791-3 3 1/8" 90° Miter Elbow, Female Outer Short Leg
- 27791-5 3 1/8" 90° Miter Elbow, Female Outer Both Legs
- 27791-7 3 1/8" 45° Miter Elbow, Female Outer Short Leg
- 27791-13 Adaptor, Female, Soft Solder
- 27791-15 Adaptor, Male, Soft Solder
- 27792-15 Adaptor, Male, Soft Solder
- 27792-1 6 1/8" T/L 20' Long (75 Ohm)
- 27792-4-CM 6 1/8" Reducer Transformer (50 Ohm to 75 Ohm)
- 19313-44 3 1/8" Fixed Hanger (Direct)
- 19313-36 3 1/8" Lateral Brace
- 19313-37 3 1/8" Swivel Hanger (Single)
- 19313-17 3 1/8" Horizontal Anchor (Single)
- 19314-32 6 1/8" Spring Hanger (Direct Mounting)
- 19314-36 6 1/8" Lateral Brace
- 19314-44 6 1/8" Fixed Hanger (Direct Mounting)

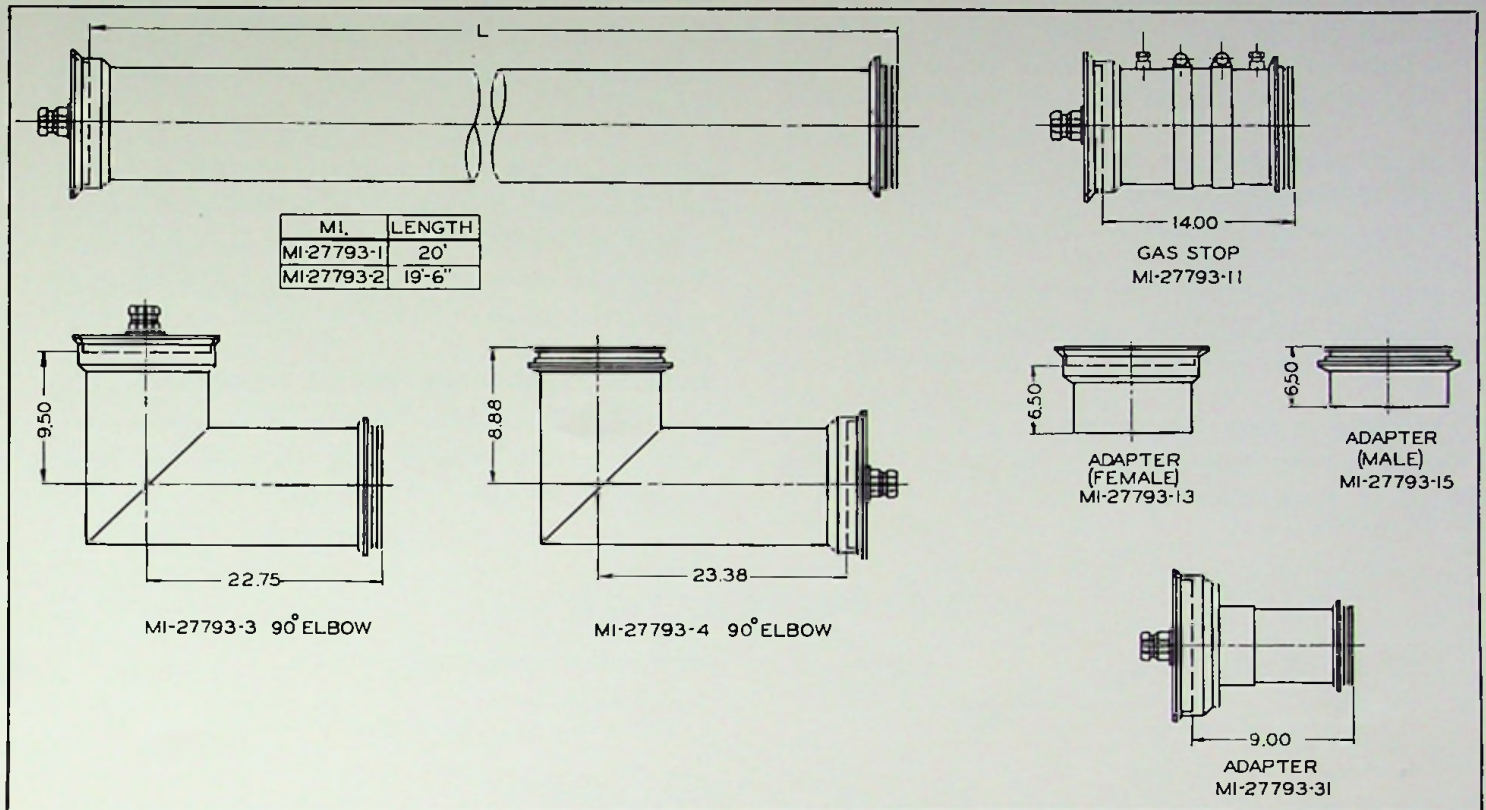
OUTLINE DRAWINGS . . . 9³/₁₆" UNIVERSAL LINE

 9³/₁₆" UNIVERSAL LINE

For highest power handling capability and extremely low attenuation, RCA provides the 9³/₁₆" Universal Transmission Line, MI-27793. It is similar to the smaller 3¹/₈" and 6¹/₈" Universal Line, the main differences being size, characteristic impedance, and power rating. Comparative curves are represented in the graphs.

MI-27793-1 TRANSMISSION LINE

This line is supplied in 20-foot lengths with flanges silver-soldered to ends. The outer conductor is 9.166" O.D. with an inner conductor of 2.580" O.D. centered by special low loss Teflon insulators. The inner conductor can be removed for inspection. It is supplied with a single anchor insulator connector (MI-27993-12), one "O" ring (MI-27793-17) and one Marman Clamp (MI-27993-18).

MI-27793-2 TRANSMISSION LINE

Same as MI-27793-1 except supplied in 19¹/₂-foot length. (See table for channels requiring 19¹/₂-foot sections.)

MI-27793-3 COUPLING, 90° ELBOW (FEMALE OUTER, SHORT LEG)

A 90° elbow fitting supplied with one "O" ring, one anchor insulator connector and a Marman clamp.

MI-27793-4 COUPLING, 90° ELBOW (MALE OUTER, SHORT LEG)

A 90° elbow fitting supplied with one "O" ring, one anchor insulator connector and one Marman clamp.

MI-27793-11 GAS STOP

Similar to gas stops used with MI-27791 and MI-27792 coaxial line, for use with 9³/₁₆" line.

MI-27793-12 CONNECTOR, INNER

Anchor insulator bullet assembly for use with 9³/₁₆" O.D. coaxial line consisting of a Teflon insulator with two spring expanders to make positive electrical contact with the inner conductor.

MI-27793-13 ADAPTOR, FEMALE (SOFT SOLDER ASSEMBLY)

A female adaptor for mechanically adapting the end of field-cut length of 9³/₁₆" line where the original silver soldered flange has been removed in shortening the line.

MI-27793-14 ADAPTOR, FEMALE (SILVER SOLDER ASSEMBLY)

Same as above only installed with silver solder.

**MI-27793-15 ADAPTOR, MALE
(SOFT SOLDER ASSEMBLY)**

A male adaptor for mechanically adapting the end of field-cut length of 9³/₁₆" line where the original silver soldered flange has been removed in shortening the line.

**MI-27793-16 ADAPTOR, MALE
(SILVER SOLDER ASSEMBLY)**

Same as above, only installed with silver solder.

MI-27793-17 GASKET ("O" RING)

A long-life synthetic rubber gasket for use between flanges to make flanged joints pressure-tight.

MI-27793-18 MARMAN CLAMP

Similar to MI-27791-18 except larger for use with 9³/₁₆" O.D. Universal transmission line.

MI-27793-31 ADAPTOR (FEMALE OUTER TO 6¹/₈"—75 OHM UNIVERSAL LINE (MI-27792) WITH MALE OUTER)

This female fitting adapts the new Universal 9³/₁₆" line to smaller Universal line 6¹/₈"—75 ohms having male outer connector.

MI-27793-32 ADAPTOR (FEMALE OUTER TO 6¹/₈"—75 OHMS UNIVERSAL LINE (MI-27792) WITH FEMALE OUTER)

A similar female fitting to adapt to 6¹/₈" line having female outer conductor.

MI-27793-33 ADAPTOR (FEMALE OUTER TO 6¹/₈"—75 OHM RETMA LINE (MI-19387)

A similar female fitting to adapt Universal 9³/₁₆" line to standard RETMA type 6¹/₈" transmission line.

SPECIFICATIONS

Electrical Specifications

	3 ¹ / ₈ " Line MI-27791	6 ¹ / ₈ " Line MI-27792	9 ³ / ₁₆ " Line MI-27793
Characteristic Impedance	50 ohms	75 ohms	75 ohms
Frequency Range.....	0-1000 mc	0-890 mc	0-632 mc
VSWR*	1.1/1 or less	1.1/1 or less	1.1/1 or less
Attenuation and Efficiency	See curves and tables	See curves and tables	See curves and tables
Power Rating	See curves	See curves	See curves
Velocity of Propagation	99.8%	99.8%	99.8%

* VSWR of transmission line run terminated in its characteristic impedance.

Mechanical Specifications

Standard Length (see table below)	20' and 19 ¹ / ₂ '	20' and 19 ¹ / ₂ '	20' and 19 ¹ / ₂ '
Outer Conductor:			
O.D.	3.125"	6.125"	9.166"
I.D.	3.027"	5.981"	9.000"
Inner Conductor:			
O.D.	1.315"	1.711"	2.580"
I.D.	1.231"	1.661"	2.516"
Weight (per section approx.)	56 lbs.	130 lbs.	220 lbs.

Channel Selection Table of Lengths

CHANNELS REQUIRING 20-FOOT SECTIONS

2, 3, 4	51, 52
5, 6, 7, 8	56, 57
9, 11, 12, 13	60, 61
14, 15	64, 65
18, 19	68, 69
22, 23, 24	72, 73
27, 28	76, 77
31, 32	80, 81
35, 36	
39, 40	
43, 44	
47, 48	

CHANNELS REQUIRING 19¹/₂-FOOT SECTIONS

10	53, 54, 55
16, 17	58, 59
20, 21	62, 63
25, 26	66, 67
29, 30	70, 71
33, 34	74, 75
37, 38	78, 79
41, 42	32, 83
45, 46	
49, 50	

SPECIFICATIONS

Optional and Accessory Equipment

Hanger, dual, grounded, direct, short length, spring	MI-19113-14
Hanger, dual, grounded, direct, short length, fixed	MI-19113-15
Hanger, insulated, direct, long length, spring	MI-19113-48
Hanger, insulated, direct, long length, fixed	MI-19113-49
Extension Kit (for making grounded long hangers of short length)	MI-19113-16
Horizontal Anchor (single line)	MI-19313-17
Horizontal Anchor (dual line)	MI-19313-18
Line Spreader	MI-19313-19
Hanger (grounded, flat, short length)	MI-19313-20
Hanger (grounded, flat, long length)	MI-19313-21
Hanger (insulated, flat, long length)	MI-19313-22
Hanger (grounded, round, short length 1" to 2 1/4")	MI-19313-23
Hanger (grounded, round, long length 1" to 2 1/4")	MI-19313-24
Hanger (insulated, round, long length 1" to 2 1/4")	MI-19313-25
Hanger (grounded, round, short length 2 1/4" to 5")	MI-19313-26
Hanger (grounded, round, long length 2 1/4" to 5")	MI-19313-27
Hanger (insulated, round, long length 2 1/4" to 5")	MI-19313-28
Hanger (grounded, angle, short length)	MI-19313-29
Hanger (grounded, angle, long length)	MI-19313-30
Hanger (insulated, angle, long length)	MI-19313-31
Hanger (grounded, direct, short length)	MI-19313-32
Hanger (grounded, direct, long length)	MI-19313-33
Hanger (insulated, direct, long length)	MI-19313-34
Roller Assembly	MI-19313-35
Lateral Brace	MI-19313-36
Hanger (swivel, for single line)	MI-19313-37
Hanger (swivel, for dual line)	MI-19313-38
Clamp (adjustable 3 1/2" max.)	MI-19313-39
Hanger (fixed, flat)	MI-19313-40
Hanger (fixed, round 1" to 2 1/4")	MI-19313-41

Hanger (fixed, round 2 1/4" to 5")	MI-19313-42
Hanger (fixed, angle)	MI-19313-43
Hanger (fixed, direct)	MI-19313-44
Hanger (fixed, direct, long length)	MI-19313-47

Large Size Hangers

	For 6 1/8" Line	For 9 3/16" Line
Hanger (grounded, direct)	MI-19314-32	MI-27900-32
Hanger (insulated, direct)	MI-19314-34	MI-27900-34
Roller Assembly	MI-19314-35	MI-27900-35
Lateral Brace	MI-19314-36	MI-27900-36
Hanger (fixed, direct)	MI-19314-44	MI-27900-44
Horizontal Anchor (single)	MI-19314-48	MI-27900-48
Horizontal Anchor (dual)	MI-19314-49	MI-27900-49
Hanger, Horizontal Spring (single)	MI-19314-50	MI-27900-50
Hanger, Horizontal Spring (dual)	MI-19314-51	MI-27900-51

Gassing Equipment

Accessory Kit for Gassing (dehydrating, single line)	MI-19315-20
Regulator for Nitrogen Gassing (2 stage)	MI-19315-21
Regulator for Nitrogen Gassing (single stage)	MI-19315-22
Accessory Kit for Nitrogen Gassing (single line)	MI-19315-24
Directional Coupler for 3 1/8"—50 ohm line	MI-27385
Directional Coupler for 6 1/8"—75 ohm line	MI-27387
Directional Coupler for 3 1/8"—50 ohm inside line	MI-27386

Other Accessories

Automatic Dehydrators to supply 1 CFM or 3 CFM of dry air are available.
 Unflanged 3 1/8"—50 ohm Teflon Transmission Line and Fittings (for ungassed VHF internal installations only) MI-27912

POWER TRANSMISSION TABLES

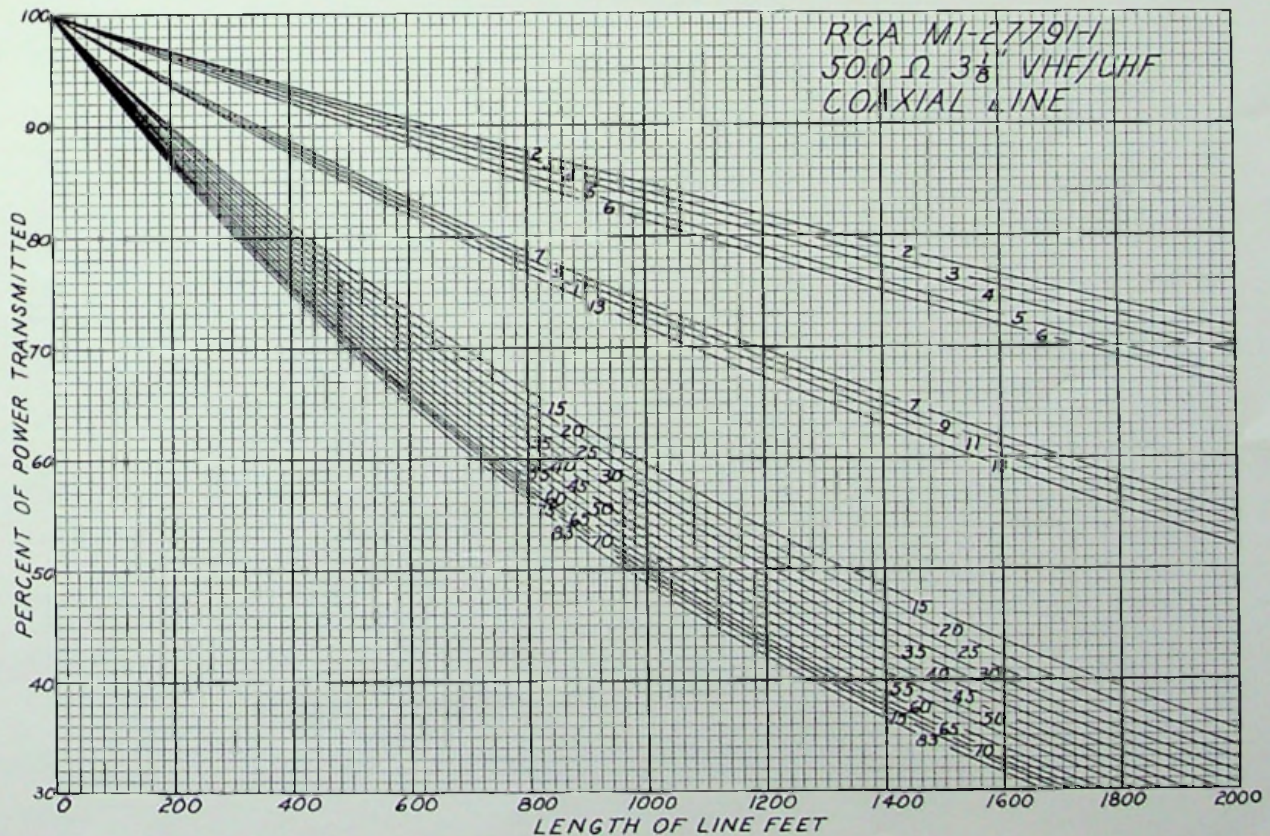

POWER TRANSMISSION TABLES

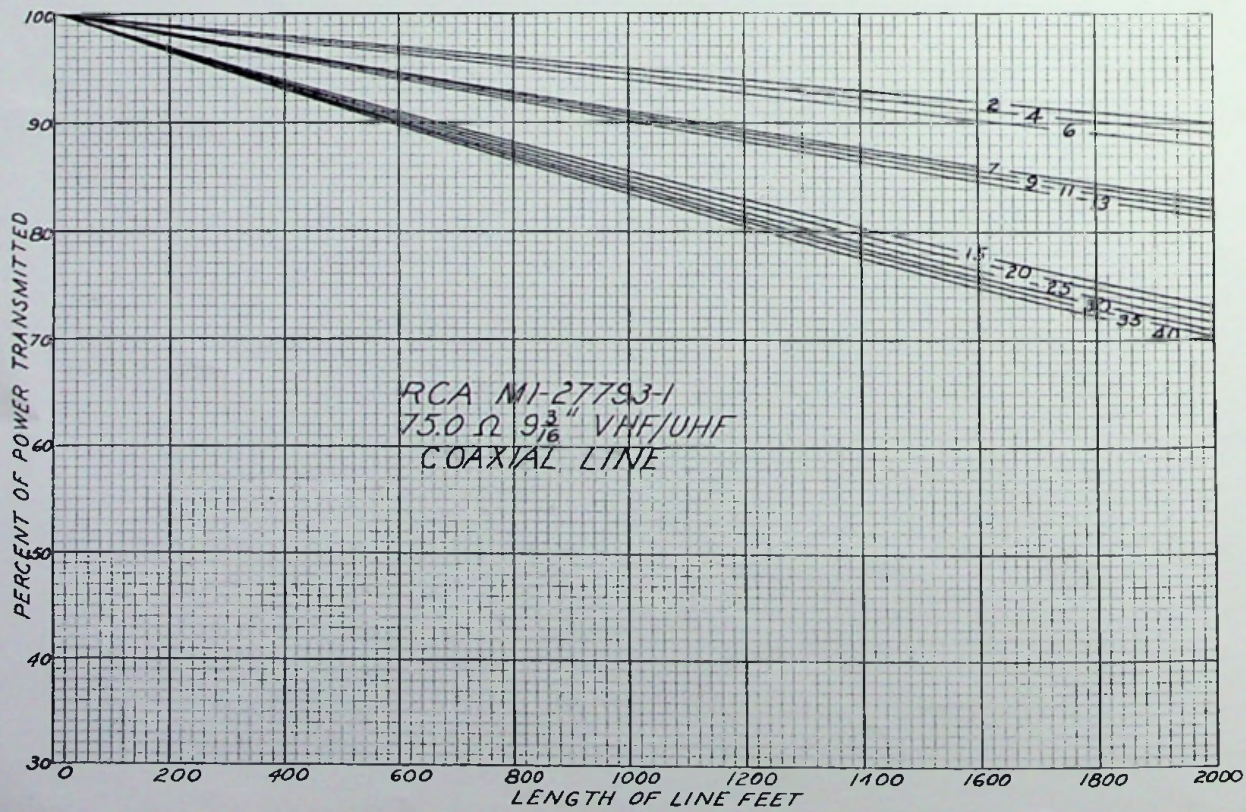
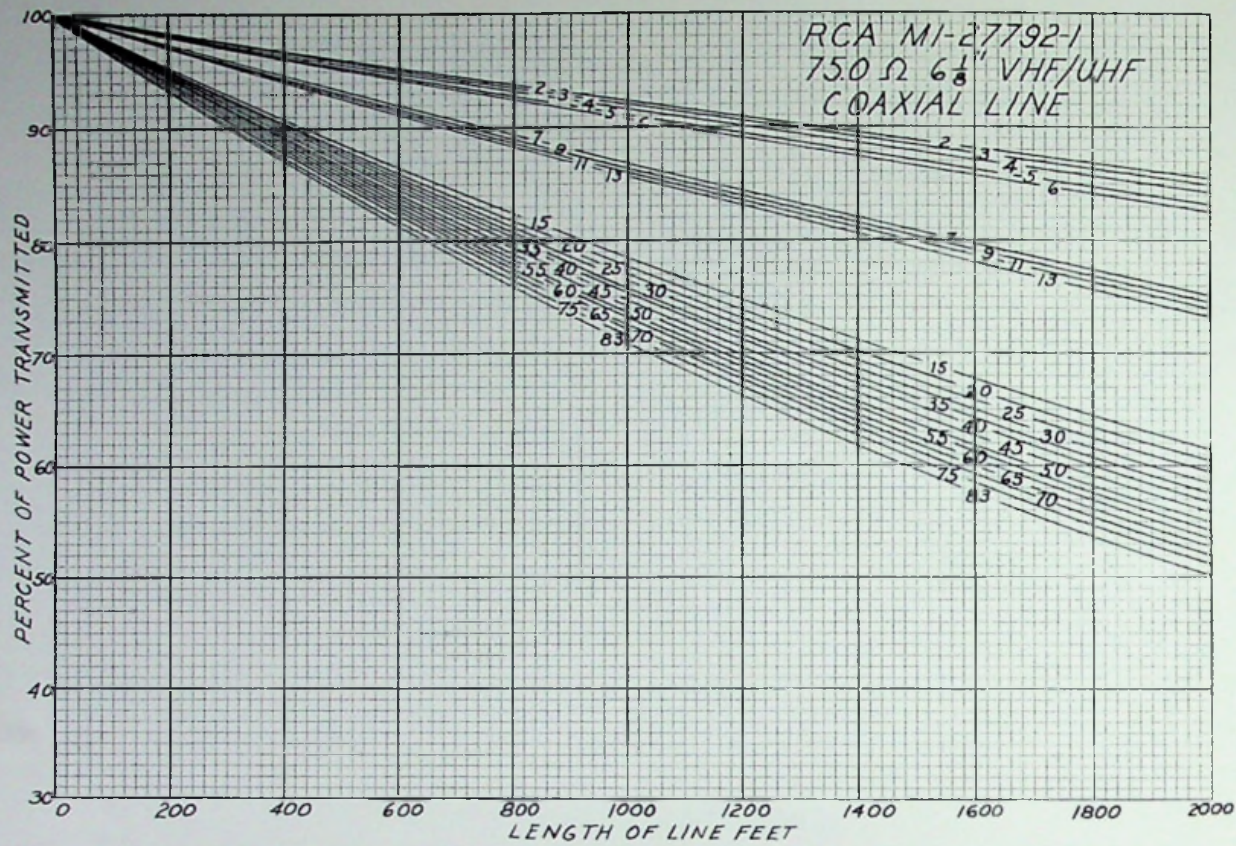

3 1/8" TEFLON UNIVERSAL TRANSMISSION LINE, MI-27791

ATTENUATION AND POWER RATING CURVES

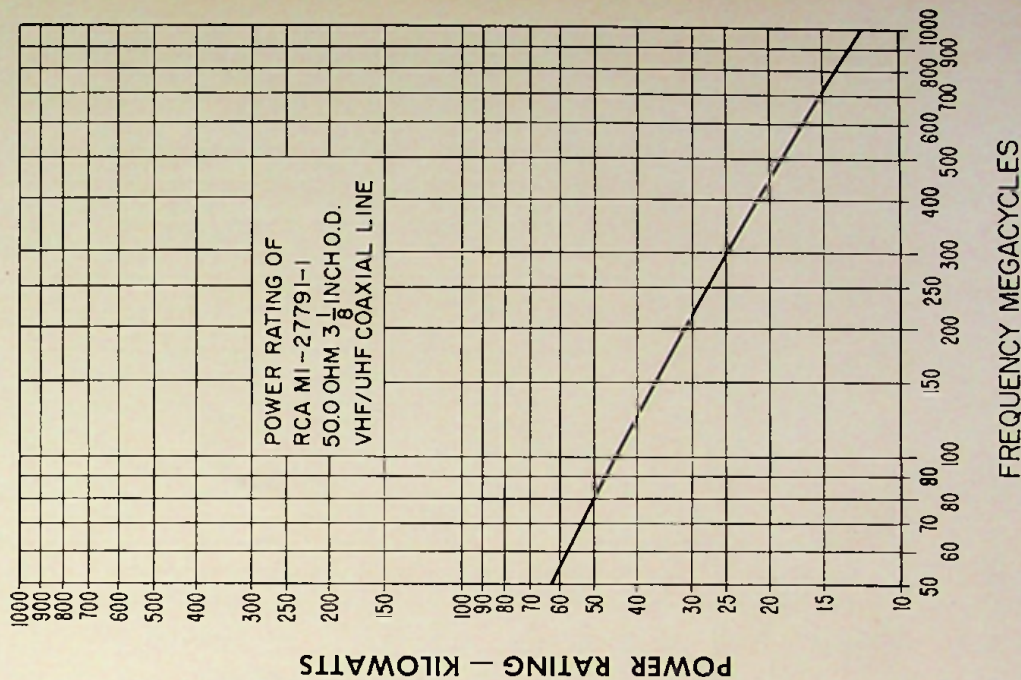
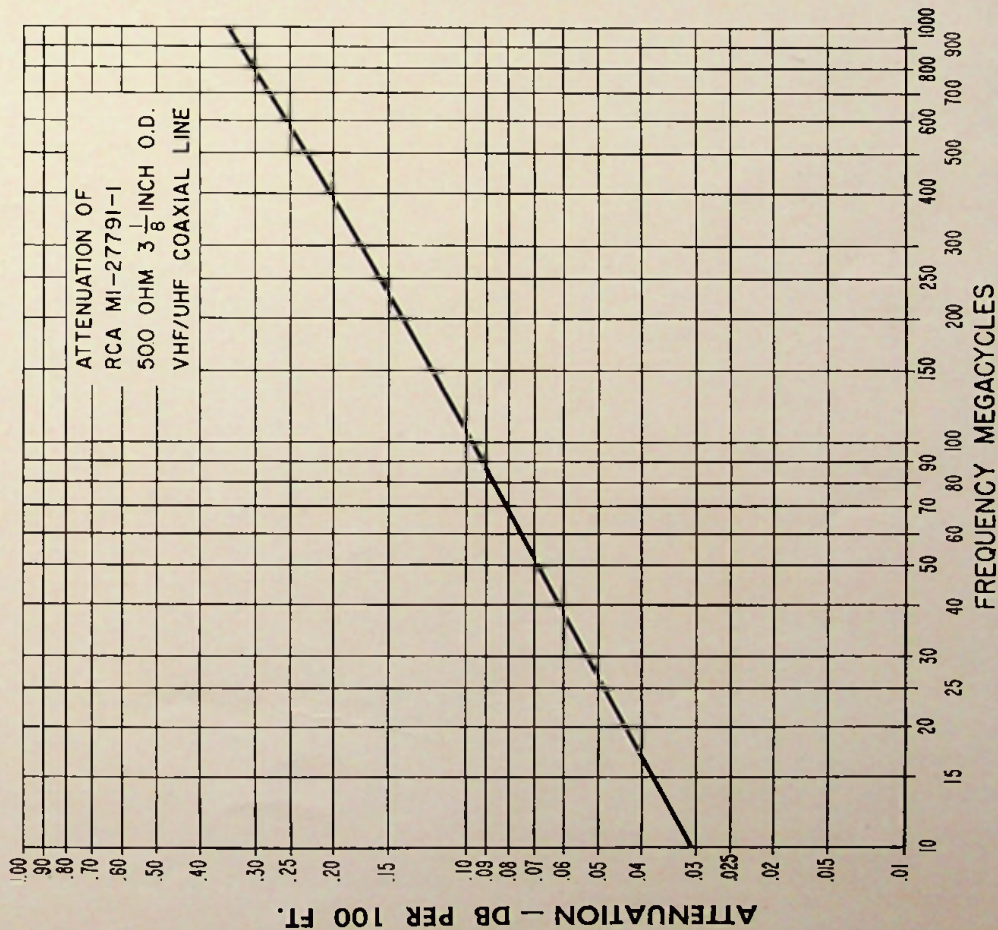

6 1/8" TEFLON UNIVERSAL TRANSMISSION LINE, MI-27792

ATTENUATION AND POWER RATING CURVES

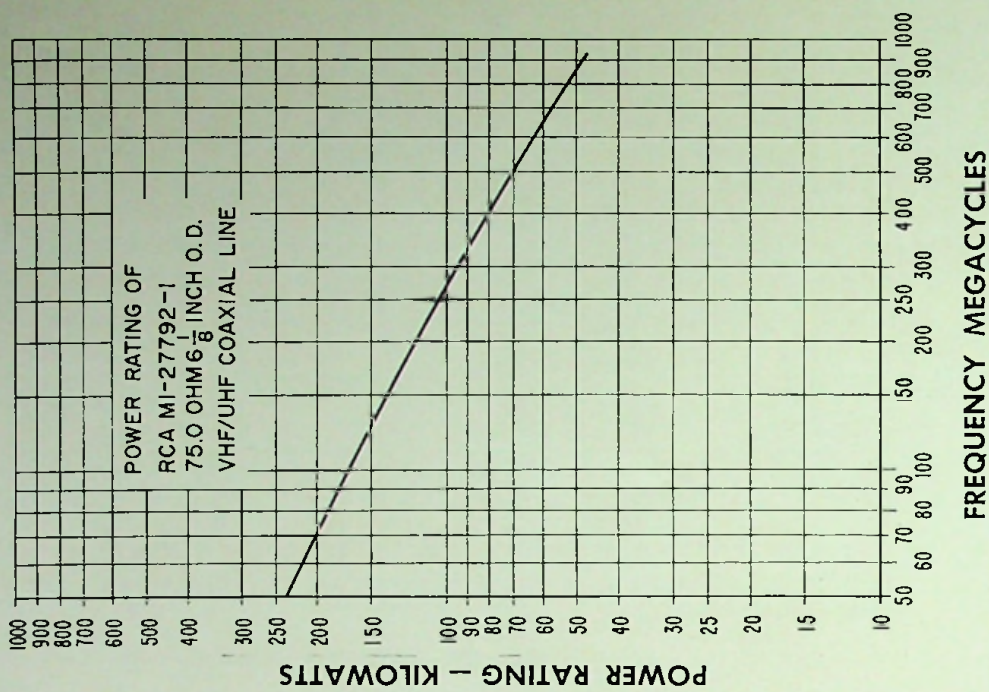
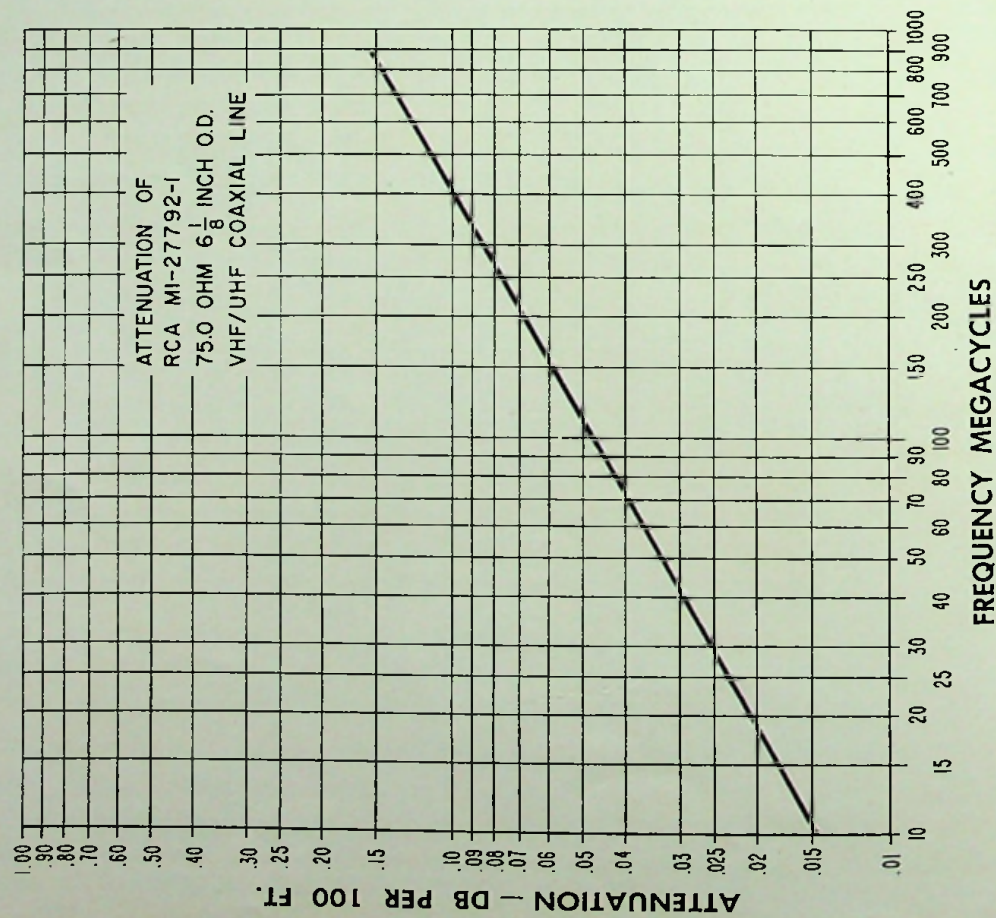

9³/₁₆" TEFLON UNIVERSAL TRANSMISSION LINE, MI-27793

ATTENUATION AND POWER RATING CURVES

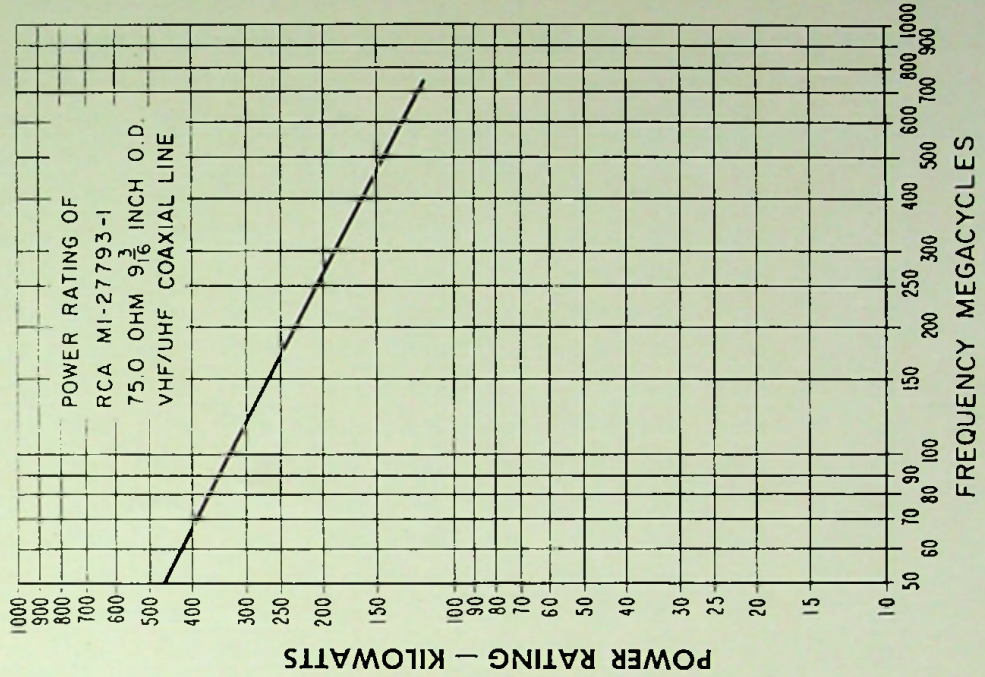
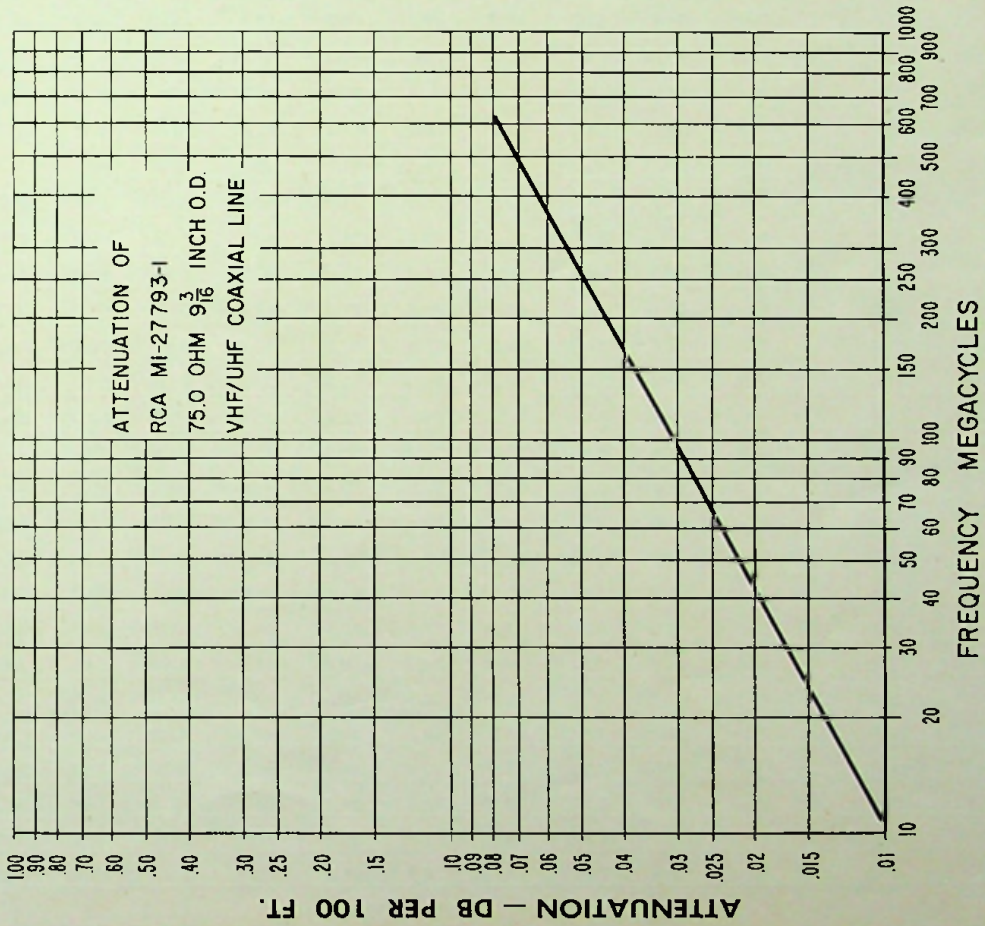

3/8" TEFLON UNIVERSAL TRANSMISSION LINE, MI-27791 — EFFICIENCY IN PER CENT

CHANNEL	DB LOSS PER 100 FT.	LENGTH IN FEET												
		100	200	300	400	500	600	700	800	900	1000	1200	1400	1600
2	.0723	98.3	96.7	95.1	93.6	92.0	90.5	89.8	87.5	86.1	84.7	81.9	79.2	76.6
3	.0762	98.3	96.6	94.9	93.2	91.6	90.0	88.4	87.0	85.4	83.9	81.0	78.2	75.5
4	.080	98.2	96.4	94.6	92.9	91.2	89.5	87.9	86.3	84.7	83.2	80.2	77.3	74.5
5	.086	98.0	96.1	94.4	92.4	90.6	88.9	87.1	85.4	83.6	82.1	78.9	75.9	72.8
6	.089	98.0	96.0	94.0	92.1	90.3	88.4	86.6	84.9	83.2	81.5	78.2	75.1	72.0
7	.130	97.0	94.2	91.4	88.7	86.1	83.6	81.1	78.7	76.4	74.1	69.9	65.8	62.0
8	.132	97.0	94.1	91.3	88.5	85.9	83.4	80.9	78.4	76.1	73.8	69.5	65.3	61.5
9	.134	97.0	94.0	91.1	88.3	85.7	83.1	80.7	78.1	75.7	73.4	69.2	64.9	61.0
10	.136	96.9	94.0	90.9	88.1	85.5	82.9	80.4	77.8	75.4	73.1	68.8	64.5	60.6
11	.138	96.9	93.8	90.9	88.1	85.3	82.6	80.1	77.6	75.1	72.8	68.3	64.1	60.2
12	.141	96.8	93.7	90.7	87.8	85.0	82.3	79.7	77.1	74.7	72.3	67.7	63.5	59.5
13	.143	96.8	93.6	90.6	87.7	84.8	82.1	79.4	76.8	74.4	71.9	67.4	63.1	59.1
14	.223	95.0	90.2	85.7	81.4	77.4	73.5	69.8	66.3	63.0	59.8	54.0	48.7	44.0
15	.225	95.0	90.2	85.6	81.3	77.2	73.3	69.6	66.1	62.7	59.6	53.7	48.4	43.7
16	.227	94.9	90.1	85.5	81.1	77.0	73.1	69.4	65.8	62.5	59.3	53.4	48.1	43.3
17	.229	94.9	90.0	85.4	81.0	76.8	72.9	69.1	65.6	62.2	59.0	53.1	47.8	43.0
18	.231	94.8	89.9	85.3	80.8	76.7	72.7	68.9	65.3	62.0	58.8	52.8	47.5	42.7
19	.233	94.8	89.8	85.1	80.7	76.5	72.5	68.7	65.1	61.7	58.5	52.5	47.2	42.4
20	.234	94.8	89.8	85.1	80.6	76.4	72.4	68.6	65.0	61.6	58.3	52.4	47.0	42.2
21	.235	94.7	89.7	85.0	80.5	76.3	72.3	68.5	64.9	61.5	58.2	52.2	46.9	42.1
22	.237	94.7	89.7	84.9	80.4	76.1	72.1	68.3	64.6	61.2	57.9	52.0	46.6	41.8
23	.239	94.6	89.6	84.8	80.2	75.9	71.9	68.0	64.4	60.9	57.7	51.7	46.3	41.5
24	.240	94.6	89.5	84.7	80.2	75.9	71.8	67.9	64.3	60.8	57.5	51.5	46.1	41.3
25	.242	94.6	89.5	84.6	80.0	75.7	71.6	67.7	64.0	60.6	57.3	51.2	45.8	41.0
26	.243	94.6	89.4	84.6	80.0	75.6	71.5	67.6	63.9	60.4	57.2	51.1	45.7	40.9
27	.245	94.5	89.3	84.4	79.8	75.4	71.3	67.4	63.7	60.2	56.9	50.8	45.4	40.6
28	.247	94.5	89.3	84.3	79.7	75.3	71.1	67.2	63.5	60.0	56.6	50.5	45.1	40.3
29	.249	94.4	89.2	84.2	79.5	75.1	70.9	67.0	63.2	60.0	56.4	50.3	44.8	40.0
30	.250	94.4	89.1	84.1	79.4	75.0	70.8	66.8	63.1	59.6	56.2	50.1	44.7	39.8
31	.252	94.4	89.0	84.0	79.3	74.8	70.6	66.6	62.9	59.3	56.0	49.8	44.4	39.5
32	.254	94.3	89.0	83.9	79.1	74.6	70.4	66.4	62.6	59.1	55.7	49.6	44.1	39.2
33	.255	94.3	88.9	83.9	79.1	74.6	70.3	66.3	62.5	59.0	55.6	49.4	43.9	39.1
34	.256	94.3	88.9	83.8	79.0	74.5	70.2	66.2	62.4	58.8	55.5	49.3	43.8	38.9
35	.257	94.3	88.8	83.7	78.9	74.4	70.1	66.1	62.3	58.7	55.3	49.2	43.7	38.8
36	.258	94.2	88.8	83.7	78.9	74.3	70.0	66.0	62.2	58.6	55.2	49.0	43.5	38.7
37	.260	94.2	88.7	83.6	78.7	74.1	69.8	65.8	61.9	58.3	55.0	48.8	43.3	38.4
38	.262	94.1	88.6	83.4	78.6	74.0	69.6	65.6	61.8	58.1	54.7	48.5	43.0	38.1
39	.264	94.1	88.6	83.3	78.4	73.8	69.4	65.3	61.5	57.9	54.5	48.2	42.7	37.8
40	.265	94.1	88.5	83.3	78.3	73.7	69.3	65.2	61.4	57.7	54.3	48.1	42.6	37.7
41	.266	94.1	88.5	83.2	78.3	73.6	69.3	65.1	61.3	57.6	54.2	48.0	42.4	37.5
42	.267	94.0	88.4	83.2	78.2	73.5	69.2	65.0	61.2	57.5	54.1	47.8	42.3	37.4

3/8" TEFLON UNIVERSAL TRANSMISSION LINE, MI-27791 — EFFICIENCY IN PER CENT (Cont'd)

CHANNEL	DB LOSS PER 100 FT.	LENGTH IN FEET													
		100	200	300	400	500	600	700	800	900	1000	1200	1400	1600	
43	.269	94.0	88.3	83.0	78.0	73.4	69.0	64.8	60.9	57.3	53.8	47.6	42.0	37.1	
44	.270	94.0	88.3	83.0	78.0	73.3	68.9	64.7	60.8	57.2	53.7	47.4	41.9	37.0	
45	.272	93.9	88.2	82.9	77.8	73.1	68.7	64.5	60.6	56.9	53.5	47.2	41.6	36.7	
46	.274	93.9	88.1	82.8	77.7	72.9	68.5	64.3	60.4	56.7	53.2	46.9	41.3	36.4	
47	.275	93.8	88.0	82.7	77.6	72.9	68.4	64.2	60.3	56.6	53.1	46.8	41.2	36.3	
48	.276	93.8	88.1	82.6	77.6	72.8	68.3	64.1	60.1	56.4	53.0	46.6	41.1	36.2	
49	.278	93.8	88.0	82.5	77.4	72.6	68.1	63.9	59.9	56.2	52.7	46.4	40.8	35.9	
50	.279	93.8	87.9	82.5	77.3	72.5	68.0	63.8	59.8	56.1	52.6	46.3	40.7	35.8	
51	.281	93.7	87.9	82.4	77.2	72.4	67.8	63.6	59.6	55.9	52.4	46.0	40.4	35.5	
52	.282	93.7	87.8	82.3	77.1	72.3	67.7	63.5	59.5	55.7	52.2	45.9	40.3	35.4	
53	.283	93.7	87.8	82.2	77.1	72.2	67.6	63.4	59.4	55.6	52.1	45.7	40.2	35.3	
54	.284	93.7	87.7	82.2	77.0	72.1	67.5	63.3	59.3	55.5	52.0	45.6	40.0	35.1	
55	.285	93.7	87.6	82.1	76.9	72.0	67.5	63.2	59.2	55.4	51.9	45.5	39.9	35.0	
56	.286	93.6	87.7	82.1	76.8	71.9	67.4	63.1	59.1	55.3	51.8	45.4	40.0	34.9	
57	.287	93.6	87.6	82.0	76.8	71.9	67.3	63.0	58.9	55.2	51.6	45.2	39.6	34.7	
58	.290	93.5	87.5	81.8	76.6	71.6	67.0	62.7	58.6	54.8	51.3	44.9	39.3	34.4	
59	.292	93.5	87.4	81.7	76.4	71.5	66.8	62.5	58.4	54.6	51.1	44.6	39.0	34.1	
60	.294	93.5	87.3	81.6	76.3	71.3	66.6	62.3	58.2	54.4	50.8	44.4	38.8	33.9	
61	.295	93.4	87.3	81.6	76.2	71.2	66.5	62.2	58.1	54.3	50.7	44.3	38.6	33.7	
62	.297	93.4	87.2	81.5	76.1	71.0	66.3	62.0	57.9	54.0	50.5	44.0	38.4	33.5	
63	.298	93.4	87.2	81.4	76.0	71.0	66.3	61.9	57.8	53.9	50.3	43.9	38.3	33.4	
64	.299	93.3	87.1	81.3	75.9	70.9	66.2	61.8	57.7	53.8	50.2	43.8	38.1	33.2	
65	.300	93.3	87.1	81.3	75.9	70.8	66.1	61.7	57.5	53.7	50.1	43.7	38.0	33.1	
66	.301	93.3	87.1	81.2	75.8	70.7	66.0	61.6	57.4	53.6	50.0	43.5	37.9	33.0	
67	.302	93.3	87.0	81.2	75.7	70.6	65.9	61.5	57.3	53.5	49.9	43.4	37.8	32.9	
68	.3025	93.3	87.0	81.1	75.7	70.6	65.8	61.4	57.3	53.4	49.8	43.4	37.7	32.8	
69	.303	93.3	87.0	81.1	75.6	70.6	65.8	61.4	57.2	53.4	49.8	43.3	37.7	32.7	
70	.3035	93.2	87.0	81.1	75.6	70.5	65.8	61.3	57.2	53.3	49.7	43.2	37.6	32.7	
71	.304	93.2	86.9	81.1	75.6	70.5	65.7	61.3	57.1	53.3	49.7	43.2	37.5	32.6	
72	.305	93.2	86.9	81.0	75.5	70.4	65.6	61.2	57.0	53.1	49.5	43.1	37.4	32.5	
73	.306	93.2	86.7	81.0	75.4	70.3	65.5	61.1	56.9	53.0	49.4	42.9	37.3	32.4	
74	.307	93.2	86.8	80.9	75.4	70.2	65.4	61.0	56.8	52.9	49.3	42.8	37.2	32.3	
75	.3075	93.2	86.8	80.9	75.3	70.2	65.4	60.9	56.8	52.8	49.3	42.8	37.1	32.2	
76	.308	93.2	86.8	80.8	75.3	70.1	65.3	60.9	56.7	52.8	49.2	42.7	37.1	32.2	
77	.3085	93.1	86.8	80.8	75.3	70.1	65.3	60.8	56.7	52.8	49.2	42.6	37.0	32.1	
78	.309	93.1	86.7	80.8	75.2	70.1	65.3	60.8	56.6	52.7	49.1	42.6	36.9	32.0	
79	.310	93.1	86.7	80.7	75.2	70.0	65.2	60.7	56.5	52.6	49.0	42.5	36.8	31.9	
80	.311	93.1	86.7	80.7	75.1	70.0	65.1	60.6	56.4	52.5	48.9	42.3	36.7	31.8	
81	.312	93.1	86.6	80.6	75.0	69.8	65.0	60.5	56.3	52.4	48.8	42.2	36.6	31.7	
82	.3125	93.1	86.6	80.6	75.0	69.8	64.9	60.4	56.2	52.3	48.7	42.2	36.5	31.6	
83	.313	93.0	86.6	80.6	75.0	69.7	64.9	60.4	56.2	52.2	48.6	42.1	36.5	31.6	

6 1/8" TEFLON UNIVERSAL TRANSMISSION LINE, MI-27792 — EFFICIENCY IN PER CENT

CHANNEL	DB LOSS PER 100 FT.	LENGTH IN FEET												
		100	200	300	400	500	600	700	800	900	1000	1200	1400	1600
2	.0339	99.2	98.5	97.7	96.9	96.2	95.4	94.7	94.1	93.2	92.5	91.1	89.6	88.3
3	.0355	99.2	98.4	97.6	96.8	96.0	95.2	94.4	93.7	92.9	92.1	90.7	89.2	87.7
4	.0372	99.1	98.3	97.5	96.6	95.8	95.0	94.2	93.4	92.6	91.8	90.2	88.7	87.2
5	.040	99.1	98.2	97.3	96.4	95.5	94.6	93.8	92.9	92.0	91.2	89.5	87.9	86.3
6	.0417	99.0	98.1	97.2	96.2	95.3	94.4	93.5	92.6	91.7	90.8	89.1	87.4	85.8
7	.0615	98.6	97.1	95.9	94.5	93.1	91.8	90.5	89.4	88.0	86.7	84.4	82.0	79.7
8	.0625	98.6	97.1	95.8	94.4	93.0	91.7	90.4	89.1	87.8	86.6	84.1	81.7	79.4
9	.0635	98.6	97.0	95.7	94.3	92.9	91.6	90.2	88.9	87.6	86.4	83.9	81.5	79.1
10	.0645	98.5	97.1	95.6	94.2	92.8	91.5	90.1	88.8	87.5	86.2	83.7	81.2	78.9
11	.0655	98.5	97.0	95.6	94.1	92.7	91.4	90.0	88.6	87.4	86.0	83.5	81.0	78.6
12	.0665	98.5	97.0	95.5	94.1	92.6	91.2	89.8	88.5	87.1	85.8	83.2	80.7	78.3
13	.0675	98.5	96.9	95.4	94.0	92.5	91.1	89.7	88.3	86.9	85.6	83.0	80.4	78.0
14	.105	97.6	95.3	93.0	90.8	88.6	86.5	84.4	82.4	80.4	78.5	74.8	71.3	67.9
15	.106	97.6	95.2	92.9	90.7	88.5	86.4	84.3	82.3	80.3	78.4	74.6	71.1	67.7
16	.107	97.6	95.2	92.9	90.6	88.4	86.3	84.2	82.1	80.1	78.2	74.4	70.8	67.4
17	.1075	97.6	95.2	92.8	90.6	88.4	86.2	84.1	82.0	80.0	78.1	74.3	70.7	67.3
18	.108	97.5	95.2	92.8	90.5	88.3	86.1	84.0	82.0	80.0	78.0	74.2	70.6	67.2
19	.109	97.5	95.1	92.8	90.5	88.2	86.0	83.9	81.8	79.8	77.8	74.0	70.4	66.9
20	.1095	97.5	95.1	92.7	90.4	88.2	86.0	83.8	81.7	79.7	77.7	73.9	70.3	66.8
21	.110	97.5	95.1	92.7	90.4	88.1	85.9	83.8	81.7	79.6	77.6	73.8	70.2	66.7
22	.111	97.5	95.0	92.6	90.3	88.0	85.8	83.6	81.5	79.4	77.5	73.6	70.0	66.4
23	.112	97.5	95.0	92.6	90.2	87.9	85.7	83.5	81.4	79.3	77.3	73.4	69.7	66.2
24	.113	97.4	94.9	92.5	90.1	87.8	85.5	83.3	81.2	79.1	77.1	73.2	69.5	65.9
25	.1135	97.4	94.9	92.5	90.1	87.8	85.5	83.3	81.1	79.0	77.0	73.1	69.4	65.8
26	.1140	97.4	94.9	92.4	90.0	87.7	85.4	83.2	81.1	79.0	76.9	73.0	69.3	65.7
27	.1145	97.4	94.9	92.4	90.0	87.7	85.4	83.1	81.0	78.9	76.8	72.9	69.1	65.6
28	.115	97.4	94.8	92.4	90.0	87.6	85.3	83.1	80.9	78.8	76.7	72.8	69.0	65.5
29	.116	97.4	94.8	92.3	89.9	87.5	85.2	83.0	80.8	78.6	76.6	72.6	68.8	65.2
30	.117	97.3	94.8	92.3	90.0	87.4	85.1	82.8	80.6	78.5	76.4	72.4	68.6	65.0
31	.1175	97.3	94.7	92.2	89.7	87.3	85.0	82.7	80.5	78.4	76.3	72.3	68.5	64.9
32	.118	97.3	94.7	92.2	89.7	87.3	85.0	82.7	80.5	78.3	76.2	72.2	68.4	64.7
33	.1185	97.3	94.7	92.1	89.7	87.2	84.9	82.6	80.4	78.2	76.1	72.1	68.3	64.6
34	.119	97.3	94.7	92.1	89.6	87.2	84.8	82.6	80.3	78.1	76.0	72.0	68.2	64.5
35	.120	97.3	94.6	92.1	89.5	87.1	84.7	82.4	80.2	78.0	75.9	71.8	67.9	64.3
36	.1205	97.3	94.6	92.0	89.5	87.0	84.7	82.3	80.1	77.9	75.8	71.7	67.8	64.2
37	.121	97.3	94.6	92.0	89.5	87.0	84.6	82.3	80.0	77.8	75.7	71.6	67.7	64.0
38	.1215	97.2	94.6	91.9	89.4	86.9	84.5	82.2	79.9	77.7	75.6	71.5	67.6	63.9
39	.122	97.2	94.5	91.9	89.4	86.9	84.5	82.2	80.0	77.7	75.5	71.4	67.5	63.8
40	.123	97.2	94.5	91.9	89.3	86.8	84.4	82.0	79.7	77.5	75.3	71.2	67.3	63.6
41	.1235	97.2	94.5	91.8	89.2	86.7	84.3	82.0	79.6	77.4	75.2	71.0	67.1	63.4
42	.124	97.2	94.5	91.8	89.2	86.7	84.3	81.9	79.6	77.3	75.2	71.0	67.1	63.3

6 1/8" TEFLON UNIVERSAL TRANSMISSION LINE, MI-27792 — EFFICIENCY IN PER CENT (Cont'd)

CHANNEL	DB LOSS PER 100 FT.	LENGTH IN FEET												
		100	200	300	400	500	600	700	800	900	1000	1200	1400	1600
43	.1245	97.2	94.4	91.8	89.2	86.6	84.2	81.8	79.5	77.3	75.1	70.9	66.9	63.2
44	.125	97.2	94.4	91.7	89.1	86.6	84.1	81.8	79.4	77.2	75.0	70.8	66.8	63.1
45	.126	97.1	94.4	91.7	89.0	86.5	84.0	81.6	79.3	77.0	74.8	70.5	66.6	62.9
46	.1265	97.1	94.3	91.6	89.0	86.4	84.0	81.6	79.2	76.9	74.7	70.0	66.5	62.7
47	.127	97.1	94.3	91.6	89.0	86.4	83.9	81.5	79.1	76.9	74.6	70.4	66.4	62.6
48	.128	97.1	94.3	91.5	88.9	86.3	83.8	81.4	79.0	76.7	74.0	70.2	66.2	62.4
49	.129	97.1	94.2	91.5	88.8	86.2	83.7	81.2	78.9	76.5	74.3	70.0	66.0	62.2
50	.130	97.1	94.2	91.4	88.7	86.1	83.6	81.1	78.7	76.4	74.1	69.8	65.8	61.9
51	.1305	97.0	94.2	91.4	88.7	86.1	83.5	81.0	78.6	76.3	74.0	69.7	65.7	61.8
52	.131	97.0	94.1	91.4	88.6	86.0	83.4	81.0	78.6	76.2	74.0	69.6	65.6	61.7
53	.132	97.0	94.1	91.3	88.5	85.9	83.3	80.8	78.4	76.1	73.8	69.4	65.3	61.5
54	.1325	97.0	94.1	91.3	88.5	85.9	83.3	80.8	78.3	76.0	73.7	69.3	65.2	61.4
55	.133	97.0	94.1	91.2	88.5	85.8	83.2	80.7	78.3	75.9	73.6	69.3	65.1	61.3
56	.1335	97.0	94.0	91.2	88.4	85.8	83.2	80.6	78.1	75.8	73.5	69.1	65.0	61.2
57	.134	97.0	94.0	91.2	88.4	85.7	83.1	80.6	78.1	75.8	73.5	69.1	64.9	61.0
58	.1345	96.9	94.0	91.1	88.3	85.7	83.0	80.5	78.0	75.7	73.4	69.0	64.8	60.9
59	.135	96.9	94.0	91.1	88.3	85.6	83.0	80.4	78.0	75.6	73.3	68.9	64.7	60.8
60	.136	96.9	93.9	91.0	88.2	85.5	82.9	80.3	77.8	75.4	73.1	68.7	64.5	60.6
61	.1365	96.9	93.9	91.0	88.2	85.5	82.8	80.3	77.8	75.4	73.0	68.6	64.4	60.5
62	.137	96.9	93.9	91.0	88.1	85.4	82.8	80.2	77.7	75.3	72.9	68.5	64.3	60.4
63	.1375	96.9	93.9	90.9	88.1	85.4	82.7	80.1	77.6	75.2	72.9	68.4	64.2	60.3
64	.138	96.9	93.8	90.9	88.1	85.3	82.6	80.1	77.6	75.1	72.8	68.3	64.1	60.2
65	.1385	96.9	93.8	90.0	88.0	85.3	82.6	80.0	77.5	75.0	72.7	68.2	64.0	60.0
66	.139	96.9	93.8	90.8	88.0	85.2	82.5	79.9	77.4	75.0	72.6	68.1	63.9	60.0
67	.140	96.8	93.8	90.8	87.9	85.1	82.4	79.8	77.3	74.8	72.4	67.9	63.7	59.7
68	.141	96.8	93.7	90.7	87.8	85.0	82.3	79.7	77.1	74.7	72.3	67.7	63.5	59.5
69	.1415	96.8	93.7	90.7	87.8	85.0	82.2	79.6	77.1	74.6	72.2	67.6	63.4	59.4
70	.142	96.8	93.7	90.7	87.7	84.9	82.2	79.5	77.0	74.5	72.1	67.5	63.3	59.3
71	.1425	96.8	93.7	90.6	87.7	84.9	82.1	79.5	76.9	74.4	72.0	67.5	63.2	59.2
72	.143	96.8	93.6	90.6	87.7	84.8	82.1	79.4	76.8	74.4	71.9	67.4	63.1	59.1
73	.1435	96.7	93.6	90.6	87.6	84.8	82.0	79.4	76.8	74.3	71.9	67.3	63.0	58.9
74	.144	96.7	93.6	90.5	87.6	84.7	82.0	79.3	76.7	74.2	71.8	67.2	62.9	58.8
75	.145	96.7	93.5	90.5	87.5	84.6	81.9	79.2	76.6	74.1	71.6	67.0	62.7	58.6
76	.1455	96.7	93.5	90.4	87.5	84.6	81.8	79.1	76.5	74.0	71.5	66.9	62.6	58.5
77	.146	96.7	93.5	90.4	87.4	84.5	81.7	79.0	76.4	73.9	71.4	66.8	62.5	58.4
78	.1465	96.7	93.5	90.4	87.4	84.5	81.7	79.0	76.3	73.8	71.4	66.7	62.4	58.3
79	.147	96.7	93.5	90.3	87.3	84.4	81.6	79.0	76.3	73.8	71.3	66.6	62.3	58.2
80	.1475	96.7	93.4	90.3	87.3	84.4	81.6	78.8	76.2	73.7	71.2	66.5	62.2	58.1
81	.148	96.7	93.4	90.3	87.3	84.3	81.5	78.8	76.1	73.6	71.1	66.4	62.1	58.0
82	.149	96.6	93.4	90.2	87.2	84.2	81.4	78.6	76.0	73.5	71.0	66.3	61.9	57.8
83	.1495	96.6	93.3	90.2	87.1	84.2	81.3	78.6	75.9	73.4	70.9	66.2	61.8	57.7

9³/₁₆" TEFLON UNIVERSAL TRANSMISSION LINE, MI-27793 — EFFICIENCY IN PER CENT

CHANNEL	DB LOSS PER 100 FT.	LENGTH IN FEET													
		100	200	300	400	500	600	700	800	900	1000	1200	1400	1600	
2	.0226	99.5	99.0	98.5	97.9	97.4	96.9	96.4	95.9	95.4	94.9	93.9	93.0	92.0	
3	.0234	99.5	98.9	98.4	97.9	97.3	96.8	96.3	95.8	95.3	94.8	93.7	92.7	91.7	
4	.025	99.3	98.9	98.3	97.7	97.2	96.6	96.1	95.5	94.9	94.4	93.3	92.3	91.2	
5	.0268	99.4	98.8	98.2	97.6	97.0	96.4	95.8	95.2	94.6	94.0	92.9	91.7	90.6	
6	.0278	99.4	98.7	98.1	97.5	96.9	96.2	95.6	95.0	94.4	93.8	92.6	91.4	90.3	
7	.0408	99.1	98.1	97.2	96.3	95.4	94.5	93.6	92.8	91.9	91.0	89.3	87.7	86.0	
8	.0413	99.0	98.1	97.2	96.3	95.4	94.5	93.6	92.7	91.8	90.9	89.2	87.5	85.9	
9	.042	99.0	98.1	97.1	96.2	95.3	94.4	93.5	92.6	91.7	90.8	89.0	87.3	85.7	
10	.0428	99.0	98.0	97.1	96.1	95.2	94.3	93.3	92.4	91.5	90.6	88.8	87.1	85.4	
11	.0435	99.0	98.0	97.0	96.1	95.1	94.2	93.2	92.3	91.4	90.5	88.7	86.9	85.2	
12	.0441	99.0	98.0	97.0	96.0	95.0	94.1	93.1	92.2	91.3	90.3	88.5	86.7	85.0	
13	.0448	99.0	98.0	97.0	96.0	95.0	94.0	93.0	92.1	91.1	90.2	88.4	86.6	84.8	
14	.0678	98.5	96.9	95.4	93.9	92.5	91.1	89.6	88.3	86.9	85.5	82.9	80.4	77.9	
15	.068	98.4	96.9	95.4	93.9	92.5	91.0	89.6	88.2	86.9	85.5	82.9	80.3	77.8	
16	.0685	98.4	96.9	95.4	93.9	92.4	91.0	89.5	88.1	86.8	85.4	82.8	80.2	77.7	
17	.069	98.4	96.9	95.3	93.8	92.4	90.9	89.5	88.1	86.7	85.3	82.6	80.1	77.6	
18	.0696	98.4	96.8	95.3	93.8	92.3	90.8	89.4	88.0	86.6	85.2	82.5	79.9	77.4	
19	.070	98.4	96.9	95.4	93.8	92.2	90.8	89.4	87.9	86.5	85.1	82.4	79.9	77.3	
20	.0704	98.4	96.8	95.3	93.7	92.2	90.7	89.3	87.8	86.4	85.0	82.3	79.7	77.2	
21	.0709	98.4	96.8	95.2	93.7	92.2	90.7	89.2	87.8	86.3	84.9	82.2	79.6	77.0	
22	.0715	98.4	96.8	95.2	93.6	92.1	90.6	89.1	87.7	86.2	84.8	82.1	79.4	76.8	
23	.072	98.4	96.7	95.1	93.6	92.0	90.5	89.0	87.6	86.1	84.7	82.0	79.3	76.7	
24	.0724	98.3	96.7	95.1	93.5	92.0	90.5	89.0	87.5	86.1	84.6	81.9	79.2	76.6	
25	.0727	98.3	96.7	95.1	93.5	92.0	90.4	88.9	87.5	86.0	84.6	81.8	79.1	76.5	
26	.073	98.3	96.7	95.1	93.5	91.9	90.4	88.9	87.4	86.0	84.5	81.7	79.0	76.4	
27	.0735	98.3	96.7	95.0	93.5	91.9	90.3	88.8	87.3	85.9	84.4	81.6	78.9	76.3	
28	.074	98.3	96.6	95.0	93.4	91.8	90.3	88.8	87.3	85.8	84.3	81.5	78.8	76.1	
29	.0745	98.3	96.6	95.0	93.4	91.8	90.2	88.7	87.2	85.7	84.2	81.4	78.6	76.0	
30	.075	98.3	96.6	94.9	93.3	91.7	90.2	88.6	87.1	85.6	84.1	81.3	78.5	75.9	
31	.0755	98.3	96.6	94.9	93.3	91.7	90.1	88.5	87.0	85.5	84.0	81.2	78.4	75.7	
32	.076	98.3	96.6	94.9	93.2	91.6	90.0	88.5	86.9	85.4	83.9	81.1	78.3	75.6	
33	.0763	98.3	96.5	94.9	92.2	91.6	90.0	88.4	86.9	85.4	83.9	81.0	78.2	75.5	
34	.0766	98.3	96.5	94.8	93.2	91.6	90.0	88.4	86.8	85.3	83.8	80.9	78.1	75.4	
35	.0768	98.3	96.5	94.8	93.2	91.5	89.9	88.4	86.8	85.3	83.8	80.9	78.1	75.4	
36	.077	98.2	96.5	94.9	93.2	91.6	89.9	88.4	86.9	85.5	83.8	80.9	78.1	75.3	
37	.0773	98.2	96.5	94.8	93.1	91.5	89.9	88.3	86.7	85.2	83.7	80.8	77.9	75.2	
38	.0777	98.2	96.5	94.8	93.1	91.4	89.8	88.2	86.7	85.1	83.6	80.7	77.8	75.1	
39	.078	98.2	96.5	94.8	93.1	91.4	89.8	88.2	86.6	85.1	83.6	80.6	77.8	75.0	
40	.0783	98.2	96.5	94.7	93.0	91.4	89.8	88.1	86.6	85.0	83.5	80.5	77.7	74.9	

VHF COAXIAL TRANSMISSION LINE

FEATURES

- Provides efficient transfer of power for TV application up to 220 mc
- Maximum stability provided by low loss dielectrics
- Minimum attenuation—maximum efficiency—low standing wave ratio
- Excellent power handling capability
- Alignment pins in each flange assure precise, accurate assembly
- Complete line of fittings and accessories for installation versatility

USES

RCA coaxial transmission line provides an efficient means of transferring r-f power to VHF television antennas. It is manufactured in various sizes and types to accommodate many different power and installation requirements.

RCA transmission line equipment features the high efficiency with which it transmits r-f energy. This line is supplied in convenient lengths with flanges silver soldered to the ends. Thus, line sections can be easily bolted together. A specially designed connector which compensates for line expansion and contraction is used for joining the inner conductors. Mating flanges are automatically sealed for pressure by insertion of a neoprene O-ring gasket before assembly.

NOTE: Transmission Lines MI-19112 and MI-19113 give satisfactory operation on channels 2 to 6; however, they are not recommended for channels 7 to 13 or when the transmission line run exceeds 500 feet.



1 $\frac{5}{8}$ " 51.5-OHM HARD COPPER LINE AND FITTINGS, MI-19112

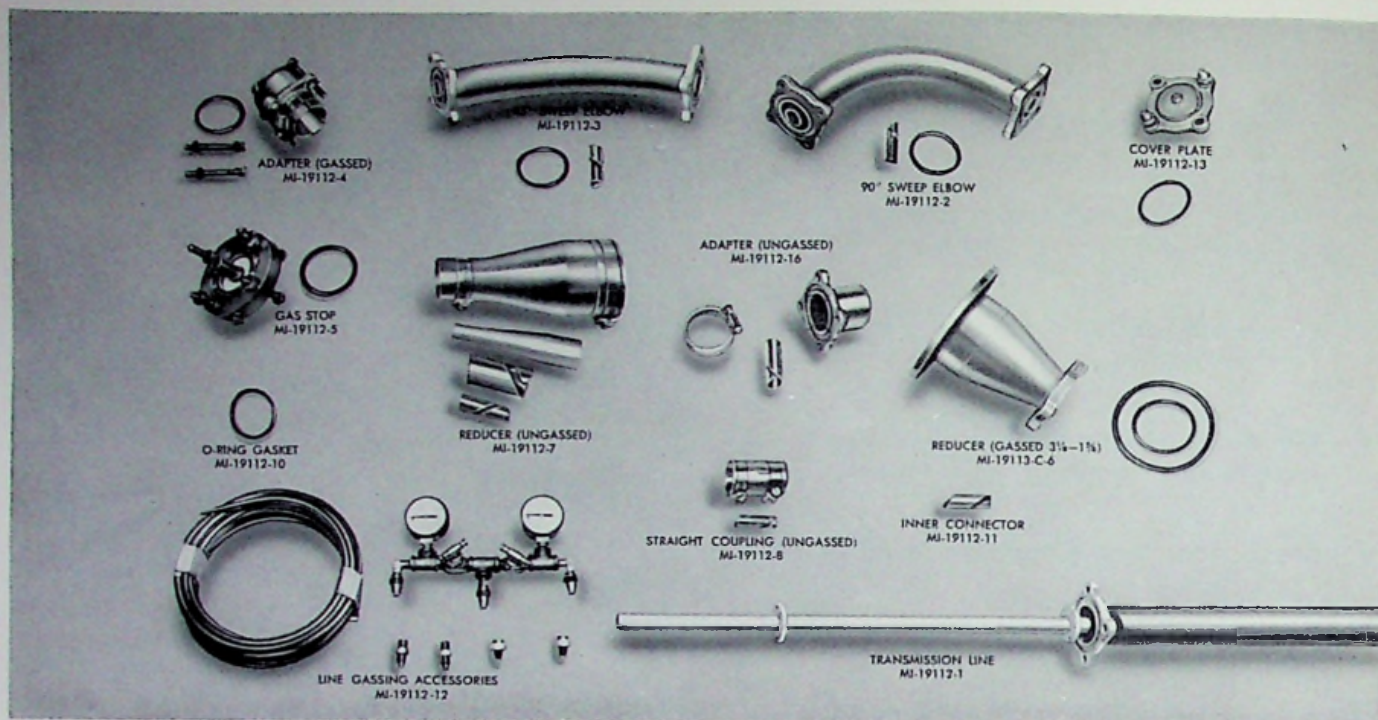

DESCRIPTION

RCA 1 $\frac{5}{8}$ " Steatite Transmission Line, Type MI-19112, is a hard-tempered copper line with a nominal impedance of 51.5 ohms. Because of its low impedance and good efficiency at VHF frequencies, this type line is widely used in TV as well as AM and FM installations.

MI-19112-1 TRANSMISSION LINE

This line is supplied in 20-foot lengths† with flanges silver-soldered to ends. The outer conductor is 1 $\frac{5}{8}$ " diameter with an inner conductor of $\frac{5}{8}$ " diameter using special low loss insulators spaced 12" apart. The outer conductor is designed to allow for removing inner conductor for inspection. Maximum power rating is 10 kw at 100 mc. Line includes solderless inner connector, O-ring gasket, and silicon copper hardware.

MI-19112-1-F TRANSMISSION LINE

Same as MI-19112-1 except one flange is omitted.

MI-19112-1-NF TRANSMISSION LINE

Same as MI-19112-1 except both flanges are omitted.

*MI-19112-2 COUPLING, 90° ELBOW

Elbow with one fixed flange and opposite flange that swivels to take care of any angle. Inner conductor is supported by insulators spaced 12" apart. There is also a support for the inner conductor in the center of

the elbow. Furnished with inner connector, O-ring gasket and silicon copper hardware.

*MI-19112-2-F COUPLING, 90° ELBOW

Same as MI-19112-2 except the fixed flange is omitted.

*MI-19112-2-NF COUPLING, 90° ELBOW

Same as MI-19112-2 except both flanges are omitted.

*MI-19112-3 COUPLING, 45° ELBOW

Same as MI-19112-2 except 45°.

*MI-19112-3-F COUPLING, 45° ELBOW

Same as MI-19112-3 except the fixed flange is omitted.

*MI-19112-3-NF COUPLING, 45° ELBOW

Same as MI-19112-3 except both flanges are omitted.

MI-19112-4 ADAPTER, FOR GASSED LINE

Used for adapting a flange type line to an unflanged line. Tools needed are wrenches for the flange hardware and screwdriver for tightening clamp. Furnished with inner connector, O-ring gasket and hardware.

MI-19112-5 GAS STOP

To be inserted between two flanged sections of line to seal a gassed section from an un-gassed section of line.

*MI-19112-6 REDUCER COUPLING

Flanged coupling used for reducing from 3 $\frac{1}{8}$ " 51.5-ohm to 1 $\frac{5}{8}$ " 51.5-ohm gassed line. Complete with inner conductor and connectors, O-ring gaskets and hardware.

† May be ordered in lengths less than 20 feet. When line is to be used for television, it should be in multiples of feet. If length is not in multiples of feet, it is necessary to make up the difference by using .647 diameter conductor MI-19112-9. When ordering specify the MI-number and length required.

* Supplied as replacement part only. Do not order for new installations.

OUTLINE DIMENSIONS . . . 1 $\frac{5}{8}$ " 51.5-OHM LINE AND FITTINGS

(MI-19112)

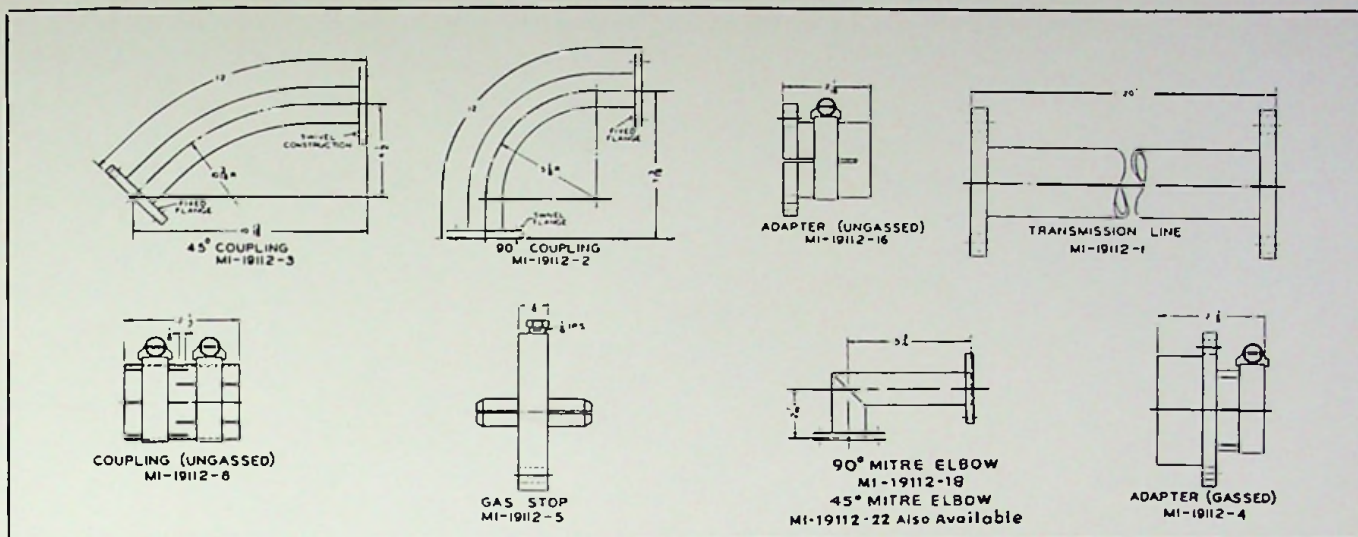

*MI-19112-7 REDUCER COUPLING

Used for reducing from 3 $\frac{1}{8}$ " 51.5-ohm to 1 $\frac{5}{8}$ " 51.5-ohm ungasged line. Complete with outer and inner conductor and connectors and stainless steel clamps.

MI-19112-8 STRAIGHT COUPLING

Used for coupling two sections of 1 $\frac{5}{8}$ " 51.5-ohm unflanged lines. (Not to be used for gassed line.) Consists of outer and inner connectors, stainless steel clamps.

MI-19112-9 SPECIAL INNER CONDUCTOR

Used for splicing lengths of line which are cut at points between the supporting insulators (these are spaced 12"). Inner conductor as supplied is .645 O.D. x .569 I.D. x 12 feet long. The special inner conductor will fit inner connector MI-19112-11.

MI-19112-10 O-RING GASKET

A long-life synthetic rubber gasket for use between the flanges to make flanged joints pressure tight.

MI-19112-11 INNER CONNECTOR

A specially designed solderless inner connector for joining inner conductors of 1 $\frac{5}{8}$ " 51.5-ohm line.

MI-19112-12 LINE GASSING ACCESSORIES

Consists of indicators, couplings, 25 ft. of $\frac{1}{4}$ " O.D. copper tubing and fittings. For indicating line pressure.

MI-19112-13 EMERGENCY COVER PLATE

Used to cap 1 $\frac{5}{8}$ " line to keep moisture out during installation, or for other temporary capping of the line.

MI-19112-16 ADAPTER

An adapter (ungassed) to couple a flanged to an unflanged line. Furnished complete with inner connector, hardware and clamp.

MI-19112-18 COUPLING, 90° MITRE ELBOW

For use where tower structure configuration or space limitations prevent use of the MI-19112-2 sweep elbow—or wherever desirable. Constructed with Teflon dielectric insulators. Excellent VSWR characteristics.

* Supplied as replacement part only. Do not order for new installations.

MI-19112-18-F COUPLING, 90° MITRE ELBOW

Same as MI-19112-18 except one flange is omitted (on the long leg).

MI-19112-18-NF COUPLING, 90° MITRE ELBOW

Same as MI-19112-18 except both flanges are omitted.

MI-19112-19 HARDWARE KIT

Consists of four bolts, four nuts and four lockwashers for 1 $\frac{5}{8}$ " line.

MI-19112-20 FLANGE, FIXED

The same flange which is used as an integral part of MI-19112 Transmission Line. Used for adapting the end of a field-cut-length of line where the original silver-soldered flange has been removed in shortening the line. Installation is made by silver soldering.

MI-19112-21 FLANGE, SWIVEL

Similar to the flange MI-19112-20 except flange is free to rotate.

MI-19112-22, 22-F, 22-NF 45° MITRE ELBOW

Similar to MI-19112-18, 18-F, 18-NF except 45°.

MI-19112-58 REDUCER, 1 $\frac{5}{8}$ " UNGASSED

A cone reducer with a special built-in connector at one end and a type "N" 51.5 ohm jack at the other. Supplied with special integral outer connector and special clamp.

MI-19112-59 REDUCER, 1 $\frac{5}{8}$ " GASSED

Similar to MI-19112-58 with flange and "O" ring for use on gassed coaxial line.

MI-19112-60 ADAPTER, FOR UNGASSED LINE

Serves similar purpose to MI-19112-4 except installed by soft soldering. Made in one piece—bolts not included. Used on ungasged coaxial line.

3/8" 51.5-OHM HARD COPPER LINE AND FITTINGS, MI-19113

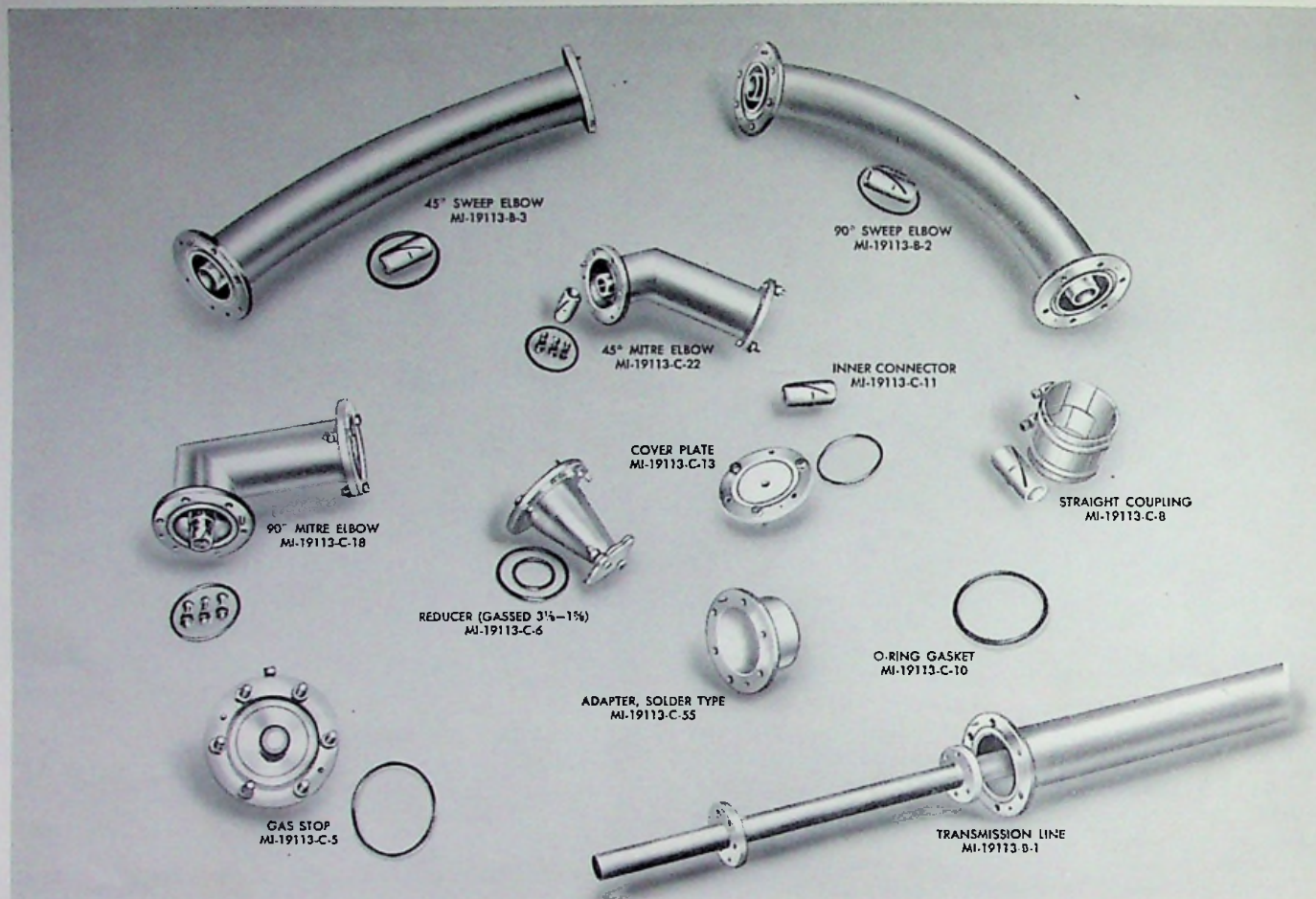

DESCRIPTION

RCA 3/8" 51.5 ohm Steatite Transmission Line, Type MI-19113, is a hard-tempered copper line designed for use in Television installations. This type line has excellent VSWR characteristics on Channels 2-6.** Its efficiency on these channels is greatly attributed to the use of a low loss dielectric. Components are ruggedly and precisely constructed. Mitre Elbows are fabricated with thick-wall tubing and Teflon dielectric inner conductor supports. A complete line of fittings and accessories provide installation versatility.

MI-19113-B-1 TRANSMISSION LINE

This line is supplied in 20-foot lengths* with flanges silver soldered to ends. The outer conductor is 3/8" O.D.

* May be ordered less than 20 feet. For television installations line sections should be in multiples of 1 foot whenever possible. Otherwise, the Special Conductor MI-19113-9 should be used to join these sections. When ordering transmission line, specify the MI-number and the length required.

** Recommended for Channels 2-6 only.

with an inner conductor of 1.200 diameter which is supported by Steatite insulators. The outer conductor is designed to allow for removing the inner conductor for inspection. Includes solderless inner connector, O-ring gasket, and silicon copper hardware.

MI-19113-B-1-F TRANSMISSION LINE

Same as MI-19113-B-1 except one flange is omitted.

MI-19113-B-1-NF TRANSMISSION LINE

Same as MI-19113-B-1 except both flanges are omitted.

*MI-19113-B-1-SF TRANSMISSION LINE

Same as MI-19113-B-1 except one of the two flanges is a swivel flange.

*MI-19113-B-2 COUPLING (90° Sweep Elbow)

Elbow with one fixed flange and opposite flange that swivels to take care of any angle. Inner conductor is supported by insulators spaced 12" apart. There is also a teflon insulator for support in the center of the elbow. Furnished with inner connector, O-ring gasket and silicon copper hardware.

* Supplied as replacement part only. Do not order for new installations.

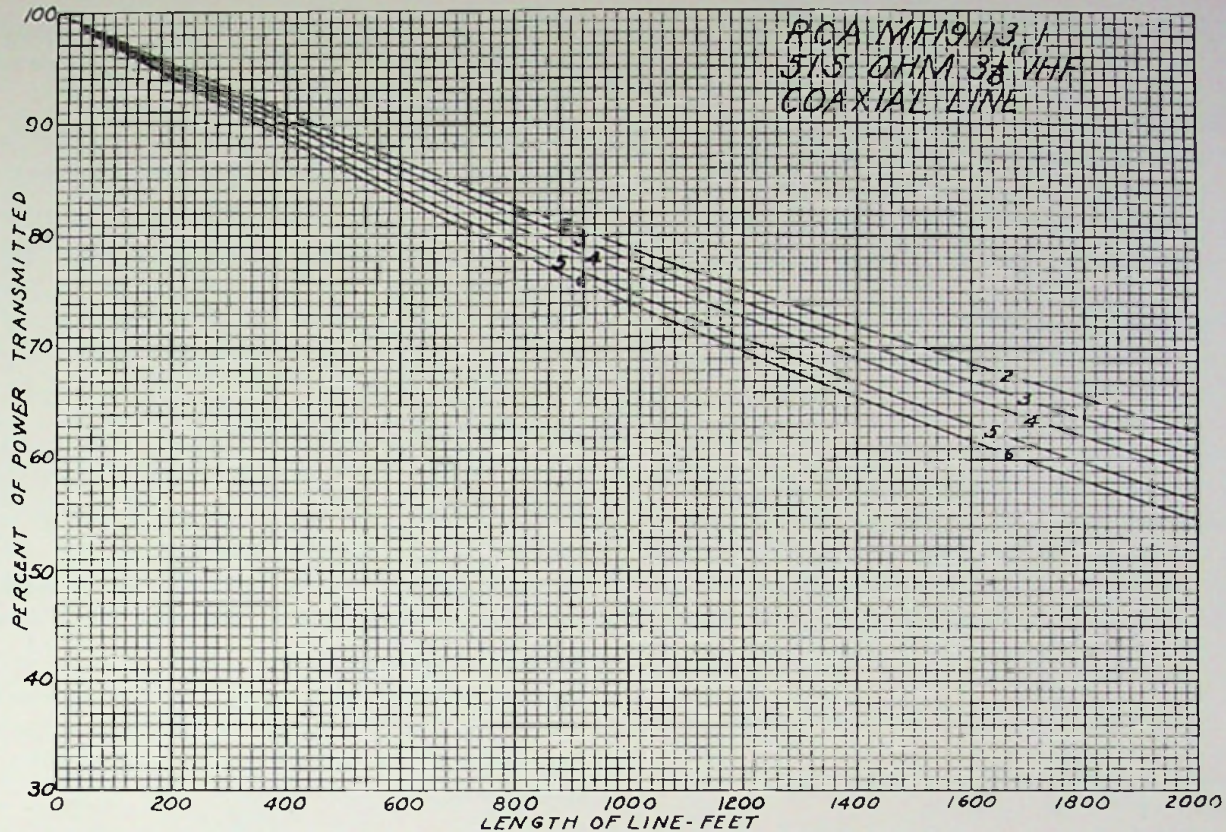
***MI-19113-B-2-F COUPLING (90° Sweep Elbow)**

Same as MI-19113-B-2 except the solid flange is omitted.

***MI-19113-B-2-NF COUPLING (90° Sweep Elbow)**

Same as MI-19113-B-2 except both flanges are omitted.

***MI-19113-B-3 COUPLING (45° Sweep Elbow)**

Same as MI-19113-B-2 except 45°.

***MI-19113-B-3-F COUPLING (45° Sweep Elbow)**

Same as MI-19113-B-3 except the solid flange is omitted.

***MI-19113-B-3-NF COUPLING (45° Sweep Elbow)**

Same as MI-19113-B-3 except both flanges are omitted.

MI-19113-C-4 ADAPTER, FOR GASED LINE

Used for adapting a flange type line to an unflanged line. The only tools necessary for installation are wrenches for the flange hardware and screwdriver for tightening clamp. Furnished with inner connector, "O" ring gasket and hardware.

MI-19113-C-5 GAS STOP

To be inserted between two flanged sections of line to seal a gassed section from an ungassed section of line.

MI-19113-C-6 REDUCER COUPLING

Flanged coupling used for reducing from 3/8" 51.5-ohm line to 1/8" 51.5 ohm line. Complete with inner conductor and connectors. O-ring gaskets and hardware.

MI-19113-C-7 REDUCER COUPLING

Used for reducing from 3/8" 51.5 ohm to 1/8" 51.5 ohm ungassed line. Complete with outer and inner conductor and connectors and stainless steel clamps.

MI-19113-C-8 STRAIGHT COUPLING

Used for coupling two sections of 3/8" 51.5-ohm unflanged lines. (Not to be used for gassed line.) Consists of outer and inner connectors with stainless steel clamps.

MI-19113-C-9 SPECIAL INNER CONDUCTOR

Used for splicing lengths of line which are cut at points between the supporting insulators (these are spaced 12"). Inner conductor as supplied is 1.282 O.D. x 1.136 I.D. x 12 feet long. The special inner conductor will fit inner connector MI-19113-C-11.

MI-19113-C-10 O-RING GASKET

A long-life synthetic rubber gasket for use between the flanges to make flanged joints pressure tight.

MI-19113-C-11 INNER CONNECTOR

A specially designed solderless inner connector for joining inner conductors of 3/8" 51.5-ohm Steatite (MI-19113) line.

MI-19113-C-13 COVER PLATE

Used to cap the end of 3/8" line to keep moisture out during installation, or for other temporary capping of the line.

MI-19113-C-17 END SEAL

Except for size and impedance this end seal is similar to MI-19112-17. The overall length is 4 1/2".

* Supplied as replacement part only. Do not order for new installations.

MI-19113-C-18 COUPLING, 90° MITRE ELBOW

A 90° Mitre Elbow having unequal-length legs with swivel flanges which provide any rotational angle. Inner conductor is supported by Teflon insulators. Furnished with two connectors, "O" ring gasket and silicon copper hardware.

MI-19113-C-18-F COUPLING, 90° MITRE ELBOW

Same as MI-19113-C-18 except the flange is omitted from the short leg.

MI-19113-C-18-NF COUPLING, 90° MITRE ELBOW

Same as MI-19113-C-18 except both flanges are omitted.

MI-19113-C-19 HARDWARE KIT

Consists of six bolts, six nuts and six lockwashers for 3 1/8 inch line.

MI-19113-C-20 FLANGE, FIXED

The same flange which is used as an integral part of MI-19113 Transmission Line. Used for adapting the end of a field-cut-length of line where the original silver-soldered flange has been removed in shortening the line. Installation is made by silver soldering.

MI-19113-C-21 FLANGE, SWIVEL

Similar to the flange MI-19113-C-20 except flange is free to rotate.

MI-19113-C-22 COUPLING, 45° MITRE ELBOW

Same as MI-19113-C-18 except 45°.

*MI-19113-C-22-F COUPLING, 45° MITRE ELBOW

Same as MI-19113-C-22 except the flange is omitted from the short leg.

* Supplied as replacement part only. Do not order for new installations.

*MI-19113-C-22-NF COUPLING, 45° MITRE ELBOW

Same as MI-19113-C-22 except both flanges are omitted.

MI-19113-C-51 CUT-OFF GAUGE

A specially-designed tool for cutting and dressing the end of the 1.282 O.D. inner conductor to insure a precision cut.

MI-19313-B-53 TRANSFORMER, 51.5 OHM TO 50.5 OHM, CHANNEL 7-13

Used for correct impedance match for Steatite line when used on Channels 7 to 13. Supplied with same hardware as MI-19113-B-1.

MI-19113-C-54 CUT-OFF GAUGE

Similar to MI-19113-C-51 except for use on 1.200 O.D. inner conductor.

MI-19113-C-55 ADAPTER, SOLDER-TYPE

Serves similar purpose to MI-19113-C-4 except installed by soft soldering. Made in one piece—bolts not included.

MI-19113-C-58 REDUCER

A cone reducer with a special built-in connector at one end and a type "N" 51.5 ohm jack at the other. Supplied with special integral outer connector and special clamp.

MI-19113-C-60 ADAPTER, FLANGED

Adapts unflanged piece of line to flanged section. Not pressure tight so use only with ungasged line. Adapter is 2 inches long.

ATTENUATION—3 1/8" LINE

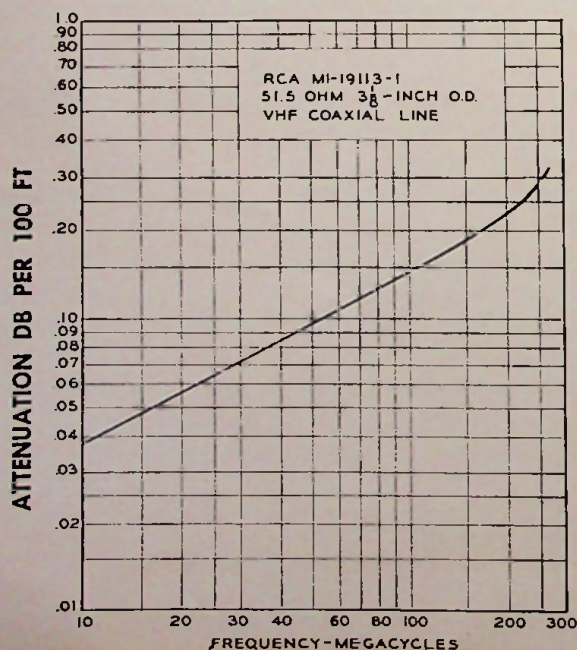

POWER RATING—3 1/8" LINE

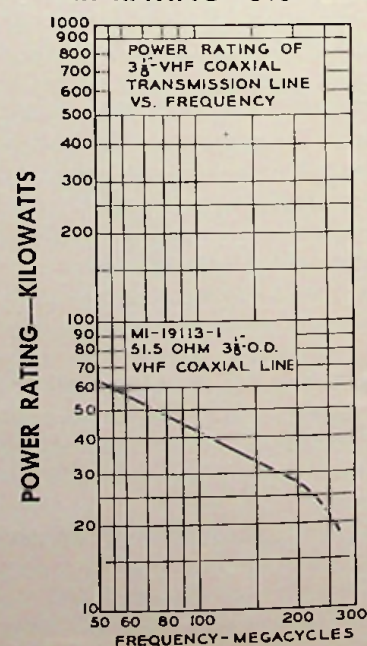

OUTLINE DIMENSIONS . . . 3 1/8" 51.5-OHM LINE AND FITTINGS

(MI-19113)

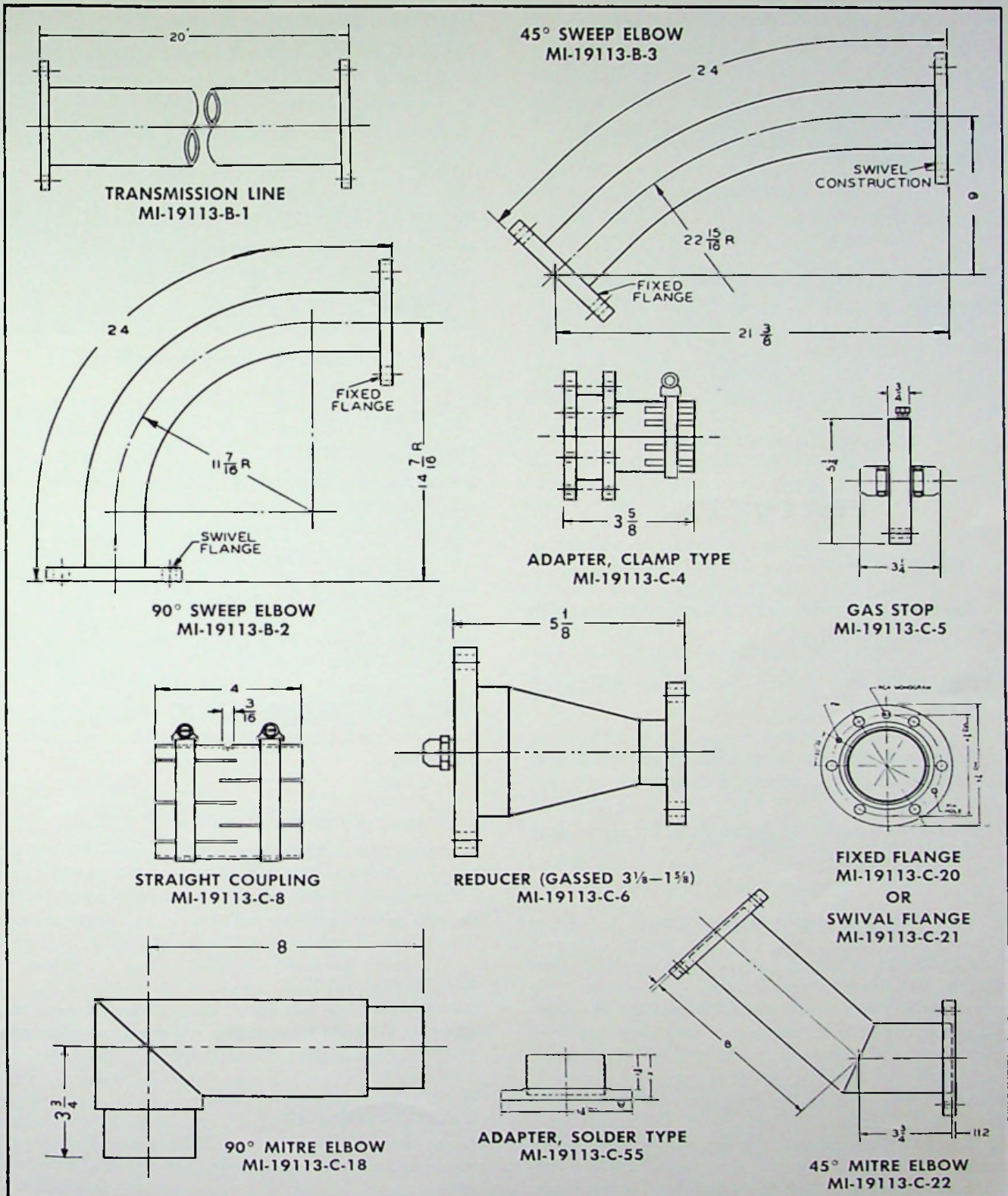

UNFLANGED 3 $\frac{1}{8}$ " 50 OHM TRANSMISSION LINE, MI-27912



3 $\frac{1}{8}$ " 50 ohm Straight Coupling.

FEATURES

- Teflon VHF line . . . developed by RCA
- Especially recommended for interior use in TV installations
- Minimum attenuation—maximum efficiency—low VSWR
- Mitre elbows for versatile installation and convenience in crowded locations
- Maximum stability provided by low loss Teflon dielectric

DESCRIPTION

RCA 3 $\frac{1}{8}$ " 50 ohm unflanged Teflon Transmission Line, Type MI-27912, is a hard-tempered copper line designed for interior use in VHF television installations. This type line has excellent VSWR characteristics and operates very efficiently at VHF Channels 2-13. Its high efficiency is greatly attributed to the use of low loss Teflon dielectric. Components are ruggedly and precisely constructed. Mitre Elbows are fabricated with thick-wall tubing. A complete line of fittings and accessories provide installation versatility. Outline dimensions for the MI-27912 components are same as MI-19113-C unflanged components.

MI-27912-1 TRANSMISSION LINE

This line is supplied in 20-foot lengths unflanged. The outer conductor is 3 $\frac{1}{8}$ " O.D. with an inner conductor of 1.315" diameter which is supported by Teflon insulators. The outer conductor is designed to allow for removing the inner conductor for inspection.

MI-27912-2 COUPLING, 90° MITRE ELBOW

A 90° Mitre Elbow having unequal length legs without flanges. The inner conductor is supported by Teflon insulators.

MI-27912-3 COUPLING, 45° MITRE ELBOW

Same as MI-27912-2 except 45°.

MI-27912-4 COUPLING

Special coupling consisting of an outer sleeve, inner connector and two adjustable clamps for joining sections of line, elbows and other line fittings.

MI-27912-5 INNER CONNECTOR

A specially designed solderless inner connector for joining the 1.315" inner conductor of MI-27912 Teflon line.

MI-27912-6 ADJUSTABLE CLAMP

A stainless steel clamp used to secure 3 $\frac{1}{8}$ " unflanged line and fittings.

MI-27912-7 ADAPTER

A clamp type adapter consisting of a female adapter, inner conductor, and adjustable clamp. It is used to adapt unflanged 3 $\frac{1}{8}$ " Teflon transmission line to MI-27791 Universal Coaxial Transmission Line.

MI-27912-8 ADAPTER

Similar to MI-27912-7 except consisting of a male outer adapter and adjustable clamp only, and used to adapt MI-27912 Transmission Line to MI-27791 Universal line.

MI-27912-9 REDUCER

An unflanged cone reducer with a special built-in connector at one end and a type "N" 50 ohm jack at the other.

6 1/8" 51.5-OHM HARD COPPER LINE AND FITTINGS, MI-19314

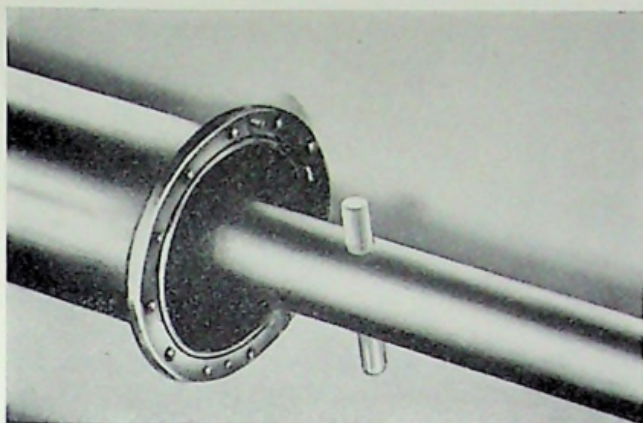

6 1/8" STEATITE TRANSMISSION LINE, MI-19314-C-1

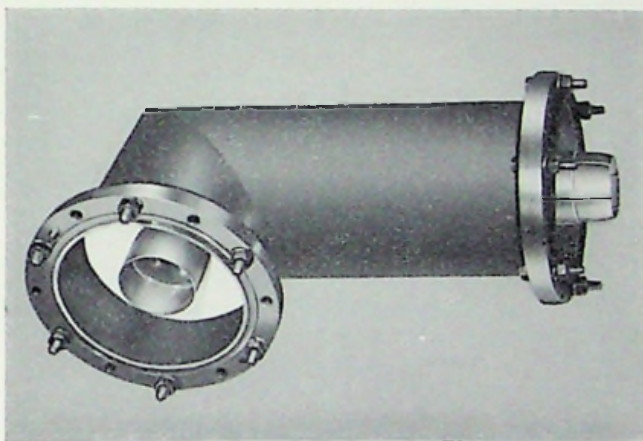

90° MITRE ELBOW, MI-19314-C-1B

DESCRIPTION

RCA 6 1/8" Steatite Coaxial Transmission Line, Type MI-19314-C is a hard-tempered copper line with an impedance of 51.5 ohms. This transmission line has an improved pin centering device and the anchor pin is locked into bosses for positive anchoring of the inner conductor. This permits shipment of the inner conductor assembled inside of the outer conductor. Maximum power 166 kw at 100 mc with 90% efficiency. Attenuation 0.056 db maximum per 100 feet at 100 mc. This line is supplied with 2 1/2" diameter inner conductor. The inner conductor is supported by ceramic pin-type insulators spaced 12 inches apart and alternately staggered 60 degrees. The large size and low impedance of this line adapts it for use in very high power TV installations. It is particularly suitable for use where the transmission line run is exceptionally long. For use on VHF Channels 2-13.

MI-19314-C-1A TRANSMISSION LINE

A 10-foot length of 6 1/8" 51.5 ohm line with no flanges. For use within the transmitter building.

MI-19314-C-1B TRANSMISSION LINE

A 19-foot length of 6 1/8" 51.5 ohm line with two fixed flanges for use on Channel 10 only.

MI-19314-C-1C TRANSMISSION LINE

Same as MI-19314-C-1B only supplied with 20-foot lengths for use on Channels 2-9 and 11-13 inclusive.

MI-19314-C-1D TRANSMISSION LINE

Similar to MI-19314-C-1C except 20-foot lengths with one fixed and one swivel flange.

MI-19314-C-1E TRANSMISSION LINE

Similar to MI-19314-C-1B except 19-foot lengths with one fixed and one swivel flange.

MI-19314-C-1F TRANSMISSION LINE

Similar to MI-19314-C-1C except 20-foot lengths with one fixed flange only.

MI-19314-C-4 REDUCER COUPLING

For connecting 6 1/8" diameter line to 3 1/8" diameter line. Flange type complete with inner conductor, O-ring gasket and hardware.

MI-19314-C-5 INNER CONNECTOR

A connector to couple the 2 1/2" diameter inner conductors of 6 1/8" line.

MI-19314-C-7 STRAIGHT COUPLING

Used for coupling two sections of 6 1/8" 51.5 ohm unflanged line. (Not to be used for gassed line.) Consists of outer and inner connectors with stainless steel clamps.

MI-19314-C-8 COVER PLATE

Used to cap the end of 6 1/8" line to keep moisture out during installation, or for other temporary capping of the line.

MI-19314-C-9 "O" RING GASKET

A long-life synthetic gasket for use between the flanges to make flanged joints pressure tight.

MI-19314-C-10 HARDWARE KIT

Consists of twelve bolts, twelve nuts and twelve lock-washers for 6 1/8" line.

MI-19314-C-11 FLANGE, FIXED

The same flange which is used as an integral part of MI-19314-C-1 Transmission Line. Used for adapting the end of a field-cut-length of line where the original silver-soldered flange has been removed in shortening the line. Installation is made by silver soldering.

OUTLINE DIMENSIONS . . . 6 1/8" 51.5-OHM LINE AND FITTINGS
(MI-19314)

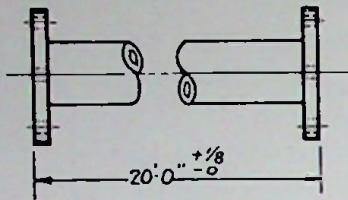

TRANSMISSION LINE
MI-19314-C-1C

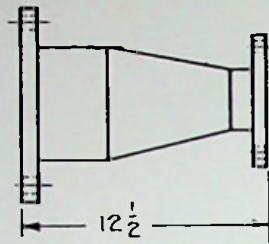

REDUCER (GASSED) 6 1/8-3 1/8
MI-19314-C-4

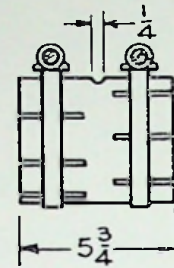

STRAIGHT COUPLING
MI-19314-C-7

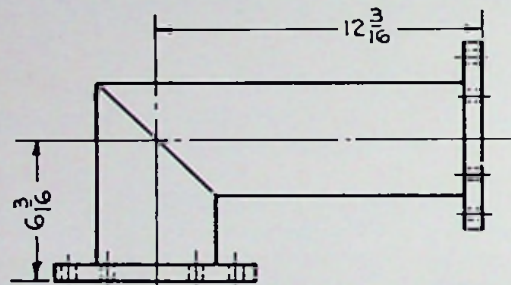

90° MITRE ELBOW
MI-19314-C-18

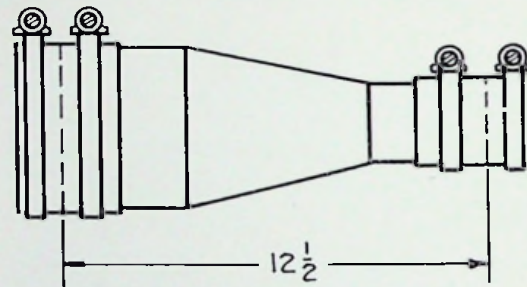

REDUCER (UNGASSED) 6 1/8-3 1/8
MI-19314-C-13

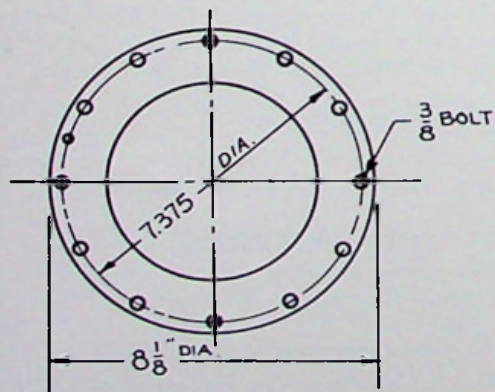

FIXED FLANGE
MI-19314-C-11
OR
SWIVEL FLANGE
MI-19314-C-12

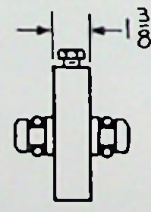

GAS STOP
MI-19314-C-52

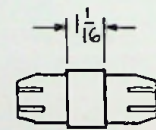

INNER CONNECTOR
MI-19314-C-5

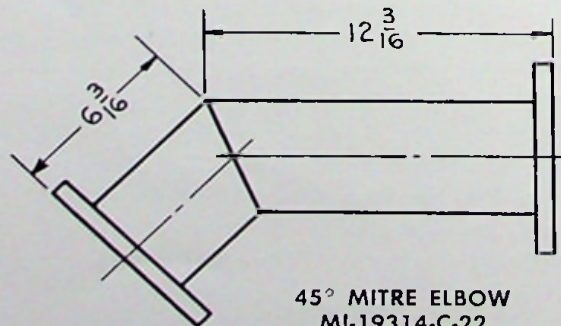

45° MITRE ELBOW
MI-19314-C-22

MI-19314-C-12 FLANGE, SWIVEL

Similar to the MI-19314-C-11 flange except free to rotate.

MI-19314-C-13 REDUCER COUPLING (Ungassed)

Used for reducing from $6\frac{1}{8}$ " 51.5 ohm Steatite line to $3\frac{3}{8}$ " 51.5 Teflon ungassed line. Outer conductor is made in one piece with a precisely supported inner conductor—provides excellent VSWR characteristic.

MI-19314-C-14 ADAPTER, SOLDER TYPE

Used for adapting the end of a field-cut-length of line where the original silver-soldered flange has been removed in shortening the line. Installation is made by soft soldering.

MI-19314-C-16 CUT-OFF GAUGE

A specially designed tool for cutting and dressing the end of a 2.500 diameter inner conductor.

MI-19314-C-18 COUPLING, 90° MITRE ELBOW

A 90° Mitre Elbow having unequal-length legs with swivel flanges providing any rotational angle. Inner conductor is supported by Teflon insulators. Furnished with two connectors, "O" ring gasket and silicon copper hardware.

MI-19314-C-18-F COUPLING, 90° MITRE ELBOW

Same as MI-19314-C-18 except with flange omitted on short leg.

MI-19314-C-18-NF COUPLING, 90° MITRE ELBOW

Same as MI-19314-C-18 except both flanges are omitted.

MI-19314-C-22 COUPLING, 45° MITRE ELBOW

A 45° Mitre Elbow having unequal-length legs with swivel flanges providing any rotational angle. Inner conductor is supported by Teflon insulators. Furnished with two connectors, "O" ring gasket and silicon copper hardware.

MI-19314-C-22-F COUPLING, 45° MITRE ELBOW

Same as MI-19314-C-22 except with flange omitted on short leg.

MI-19314-C-22-NF COUPLING, 45° MITRE ELBOW

Same as MI-19314-C-22 except both flanges are omitted.

MI-19314-C-23 SPECIAL INNER CONDUCTOR

Used for splicing lengths of line which are cut at points between the supporting insulators (these are spaced 12"). Inner conductor as supplied is 2.532" O.D. x 12 feet long. The special inner conductor will fit inner connector MI-19314-C-5.

MI-19314-C-39 HOSE CLAMP

Stainless steel clamp adjustable to $6\frac{1}{8}$ " maximum.

MI-19314-C-52 GAS STOP

To be inserted between two flanged sections of line to seal a gassed section from an ungassed section of line.

MI-19314-C-53 TOOL KIT

Kit consisting of one Forked Spreader and one $\frac{3}{16}$ " hex "T" wrench 12 $\frac{3}{4}$ " long for adjusting anchor pin assembly of MI-19314 Steatite Coaxial Transmission Line.

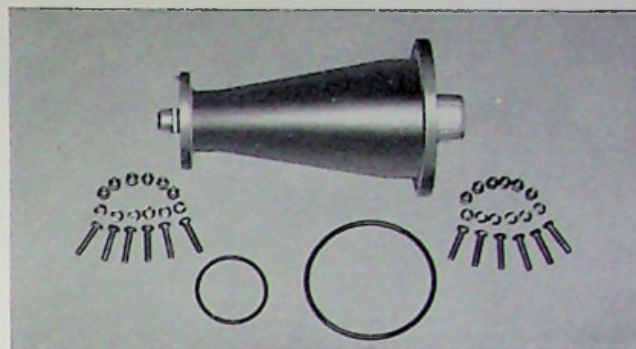

REDUCER COUPLING, MI-19314-C-4

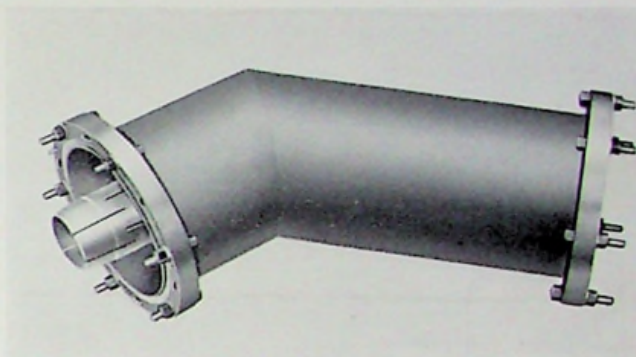

45° MITRE ELBOW, MI-19314-C-22

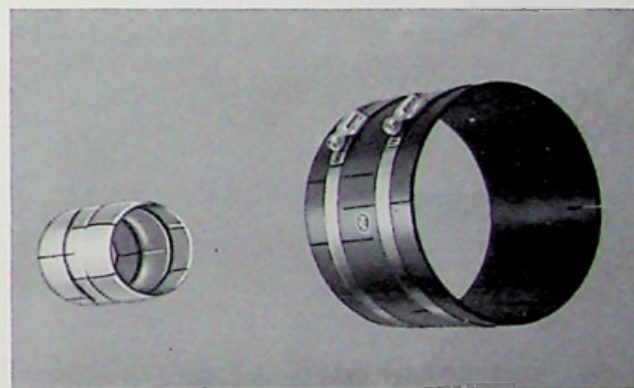

STRAIGHT COUPLING, MI-19314-C-7

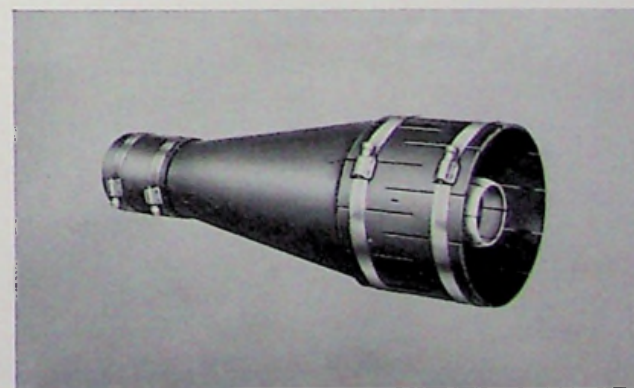

REDUCER COUPLING, MI-19314-C-13

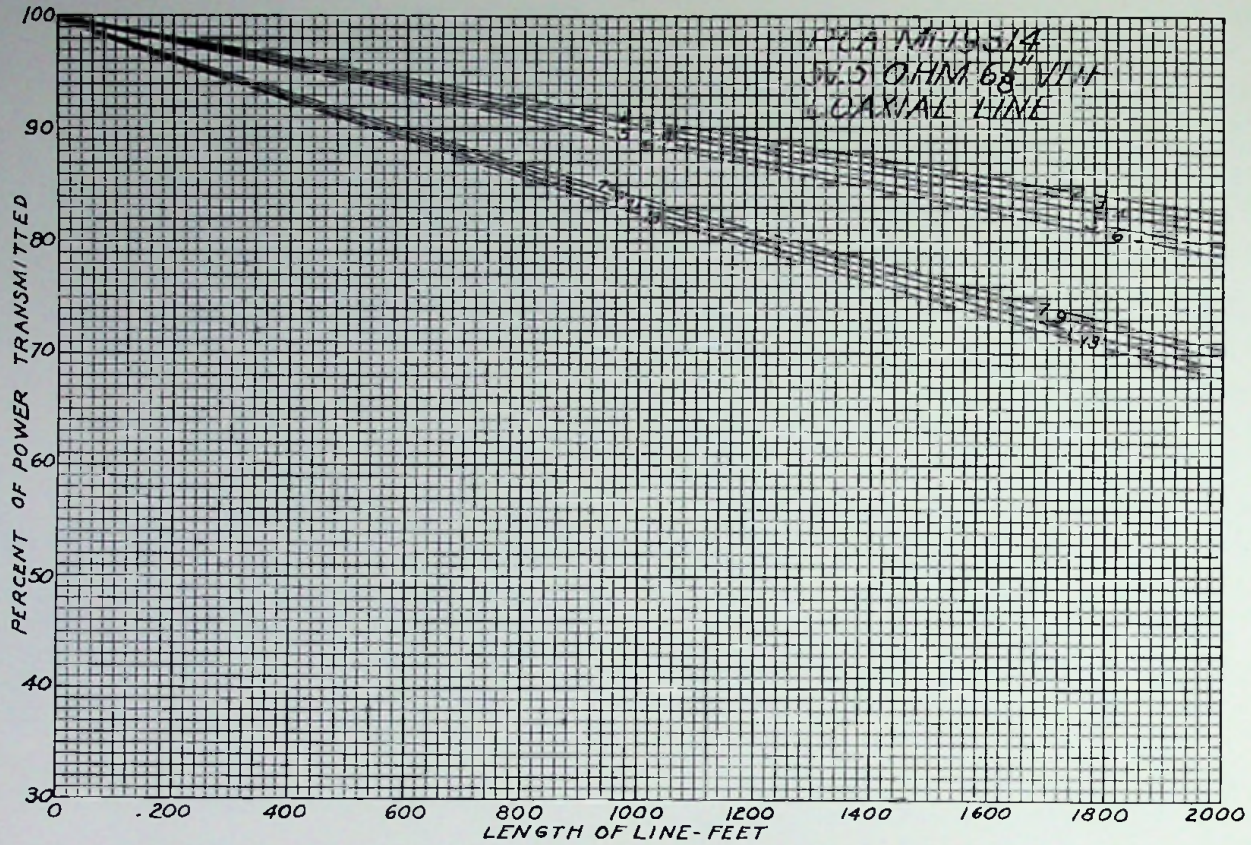

ATTENUATION—6 1/8" LINE

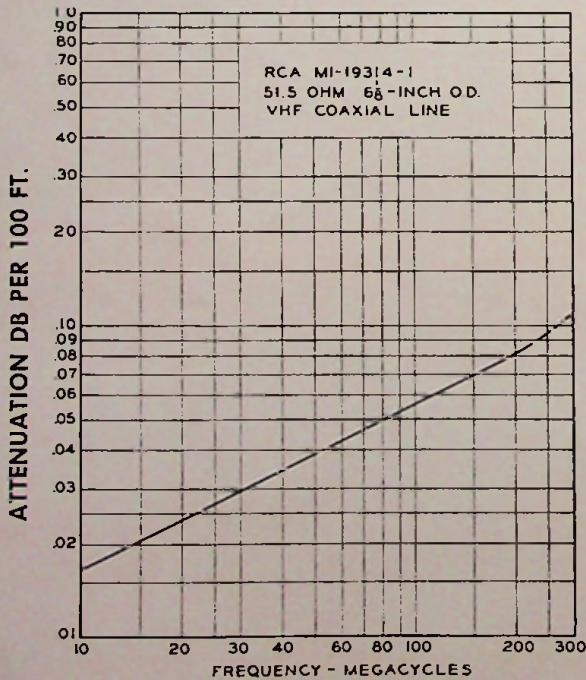

POWER RATING—6 1/8" LINE

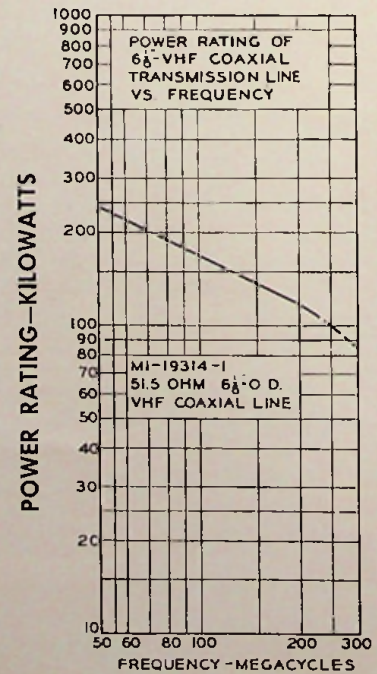

EFFICIENCY CURVES ON RCA 1⁵/₈" VHF COAXIAL TRANSMISSION LINE

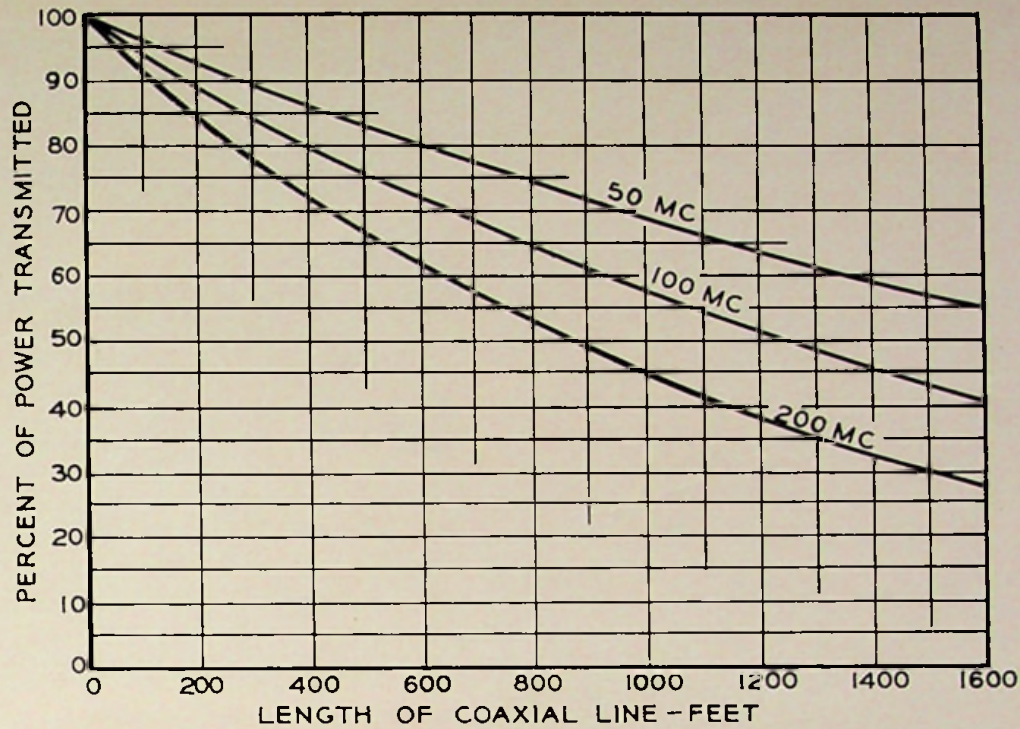

3¹/₈" 51.5 OHM HARD COPPER VHF TRANSMISSION LINE, MI-19113

CHANNEL	DB LOSS PER 100 FT.	LENGTH IN FEET												
		100	200	300	400	500	600	700	800	900	1000	1200	1400	1600
2	.1018	97.7	95.4	93.2	91.1	88.9	86.9	84.9	82.9	81.0	79.1	75.5	72.0	68.7
3	.1081	97.5	95.2	92.8	90.5	88.3	86.1	84.0	82.0	79.9	78.0	74.2	70.6	67.2
4	.1146	97.4	94.9	92.4	90.0	87.6	85.4	83.1	81.0	78.9	76.8	72.9	69.1	65.6
5	.1246	97.2	94.4	91.8	89.2	86.6	84.2	81.8	79.5	77.2	75.1	70.9	66.9	63.2
6	.1306	97.0	94.2	91.4	88.7	86.0	83.5	81.0	78.6	76.3	74.0	69.7	65.6	61.8

6¹/₈" 51.5 OHM HARD COPPER VHF TRANSMISSION LINE, MI-19314

CHANNEL	DB LOSS PER 100 FT.	LENGTH IN FEET												
		100	200	300	400	500	600	700	800	900	1000	1200	1400	1600
2	.0415	99.1	98.1	97.2	96.3	95.3	94.4	93.5	92.6	91.8	90.9	89.2	87.5	85.8
3	.0437	99.0	98.0	97.0	96.1	95.1	94.1	93.2	92.3	91.3	90.4	88.6	86.9	85.1
4	.0459	99.0	97.9	96.9	95.9	94.9	93.9	92.9	91.9	90.9	90.0	88.1	86.2	84.5
5	.0494	98.9	97.8	96.7	95.6	94.5	93.4	92.3	91.3	90.3	89.3	87.2	85.3	83.4
6	.0514	98.8	97.7	96.5	95.4	94.2	93.1	92.1	91.0	89.9	88.8	86.8	84.7	82.8
7	.0761	98.3	96.6	94.9	93.2	91.6	90.0	88.5	86.9	85.4	83.9	81.0	78.3	75.6
8	.0774	98.2	96.5	94.8	93.1	91.5	89.9	88.3	86.7	85.2	83.7	80.7	77.9	75.2
9	.0788	98.2	96.4	94.7	93.0	91.3	89.7	88.1	86.5	84.9	83.4	80.4	77.6	74.8
10	.0801	98.2	96.4	94.6	92.9	91.2	89.5	87.9	86.3	84.7	83.2	80.2	77.2	74.4
11	.0815	98.2	96.3	94.5	92.8	91.0	89.4	87.7	86.1	84.5	82.9	79.8	76.9	74.1
12	.0828	98.1	96.3	94.4	92.7	90.9	89.2	87.5	85.9	84.2	82.6	79.6	76.6	73.7
13	.0840	98.1	96.2	94.4	92.6	90.8	89.0	87.3	85.7	84.0	82.4	79.3	76.3	73.4

INSTALLATION AND LAYOUT OF TRANSMISSION LINES

Before ordering transmission line or fittings, it is recommended that a dimensioned layout be made of the tower or supporting structure (with antenna mounted), the routing of the transmission line between the tower and transmitter room, and routing of the lines within the transmitter room. This layout will give an idea as to what elbows and fittings will be needed and the length of line required. Reference to layout chart will aid in determining list of items to be ordered. The standard lengths of transmission are 19½' and 20 feet. Shorter lengths may be obtained by ordering the desired length with flanges soldered on at the factory, or a 20-foot section may be cut and a soft solder adaptor used. The RCA MI-19113 lines have a rolled groove in one end of each of the outer conductors to prevent the inner conductor from moving in one direction. The opposite end is free to permit removal of the inner conductor and insulators, for inspection. The rolled groove supports the end insulator and also the inner conductor when the line is in a vertical position, and this end should always be placed in the lower position to prevent the inner conductor from dropping out. For horizontal runs, rolled groove is placed at alternate joints so that for each two adjacent sections the line is locked in position by the opposing rolled grooves. RCA MI-19312 are similarly installed, but the inner conductor on this line cannot be removed without the aid of special tools. Removal is not recommended.

All RCA lines and fittings that are to be used outdoors should use the flange type line. The unflanged lines may be used inside buildings where gassing may not be necessary or where changes in transmission line connections are frequently made for tests. An O-ring gasket is supplied which fits into a groove of each mating flange of the flanged line. Also included are bolts, lock washers, and nuts made of silicon copper for each coupling. Care must be exercised when placing the gasket in the groove to avoid pinching the gasket. If the gasket is not assembled properly, a pressure leak may result. It is suggested that additional gaskets, bolts, and O-rings should be ordered to replace damage and loss during installation.

The gassed lines should be brought inside the building and connected to a gas stop. Assemble the gas stop with the pipe plug toward the gassed line. From the gas stop to a transmitter, flanged or unflanged line may be used.

There is a wide choice of hangers for supporting the transmission line. See tables, photos and drawings in the Transmission Line and Accessories catalog . . . B.5050. For longer runs, the roller assembly, MI-19312-35, MI-19313-35 or MI-19314-35, is recommended. If it is necessary to run a line through a wall or building, make a hole large enough to clear the diameter of a transmission line flange and mount MI-19312-17 or -18, MI-19313-17 or -18, MI-19314-48 or MI-19314-52 horizontal anchors on both sides of the wall securing same with bolts. A detailed

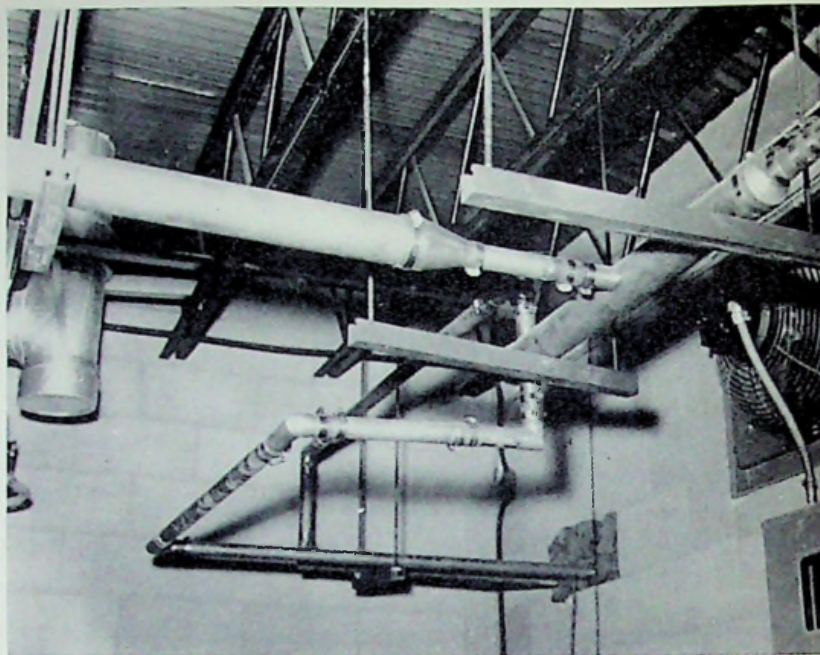

View at rear of transmitter showing typical mounting of diplexer and phasing section utilizing 1½" transmission line for construction of phasing section and 3½" Teflon line in balance of installation.

description for each type hanger is given in the hanger section catalog B.5050.

Do not make up an installation in rainy or stormy weather unless the ends of the transmission line and fittings are protected from moisture. If it is necessary to stop work on an installation, cover both ends of the line to keep water out. If water gets into the line in cold weather, it may freeze and crack the line. This is very important since water can be trapped in low sections of line or antenna harnesses and it is difficult to purge from the line with the result that high standing wave ratios may be set up that will permanently damage the line or antenna. Even at normal temperature, if water gets in the line it is difficult to dry out the line by gas or air pressure. A cover plate, MI-19112-13, MI-19113-13 or MI-19314-8, may be used for closing off the line temporarily. After the complete installation, open up a bleeder valve at the antenna end and apply dry gas or dry air under pressure until all moisture has been blown out after which the bleeder valve must be closed. It is advisable to measure the insulation resistance with a voltohmyst and bleed the line until 80 megohms or more resistance is obtained. Care should be exercised not to drop the transmission line as the insulators may break. Do not bend the line more than that listed in the upper portion of the layout chart.

TV INSTALLATIONS

Bridge diplexers are usually used with TV Super Turnstile Antennas and two transmission lines are used. One line is a quarter wave longer than the other. The quarter wave extra length in one line is usually installed inside the building near the diplexer unit. It is very important to keep the lines exactly the same length to the point of the phasing section. This includes all of the elements in the system such as elbows, reducers, etc. A typical TV installation and a material list appears on the following page. In TV is mandatory that the MI-19113 and MI-19314 transmission lines, if cut, must be cut at the 1-foot interval marks placed on the outer conductor of the line; or if cut at other points, that a special inner conductor be utilized. These precautions are necessary to avoid an increase in standing wave ratio. It is also important that after receipt, the inner conductor be withdrawn and checked for bends and insulators checked for transportation damage. A broken insulator will make a noticeable change in the standing wave ratio. The routing of the TV lines should be designed to keep the number of elbows and reducers at a minimum for the purpose of obtaining lowest possible standing wave ratios.

Typical VHF Transmission Line run from diplexer through building wall to exterior tower. ▶

Exterior transmission line run where ice deflecting canopy safeguards horizontal run against possible falling ice. Transmission line runs to tower should be short as possible and number of elbows held to a minimum. ▼

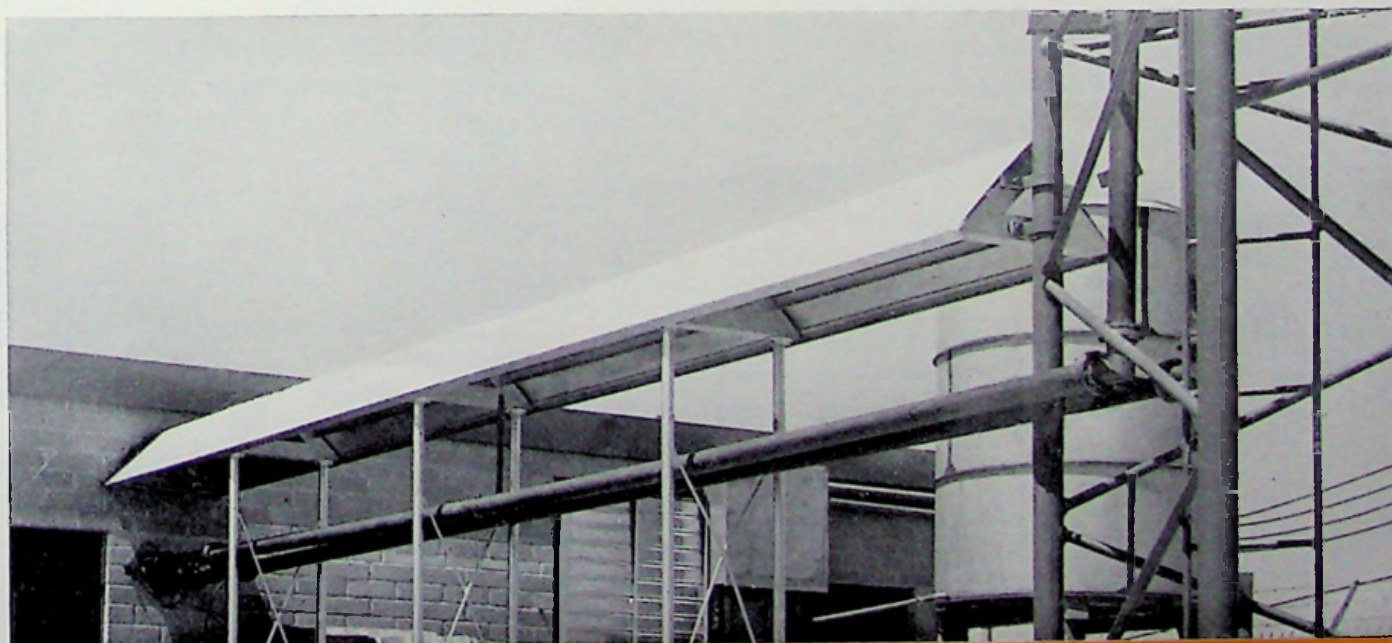
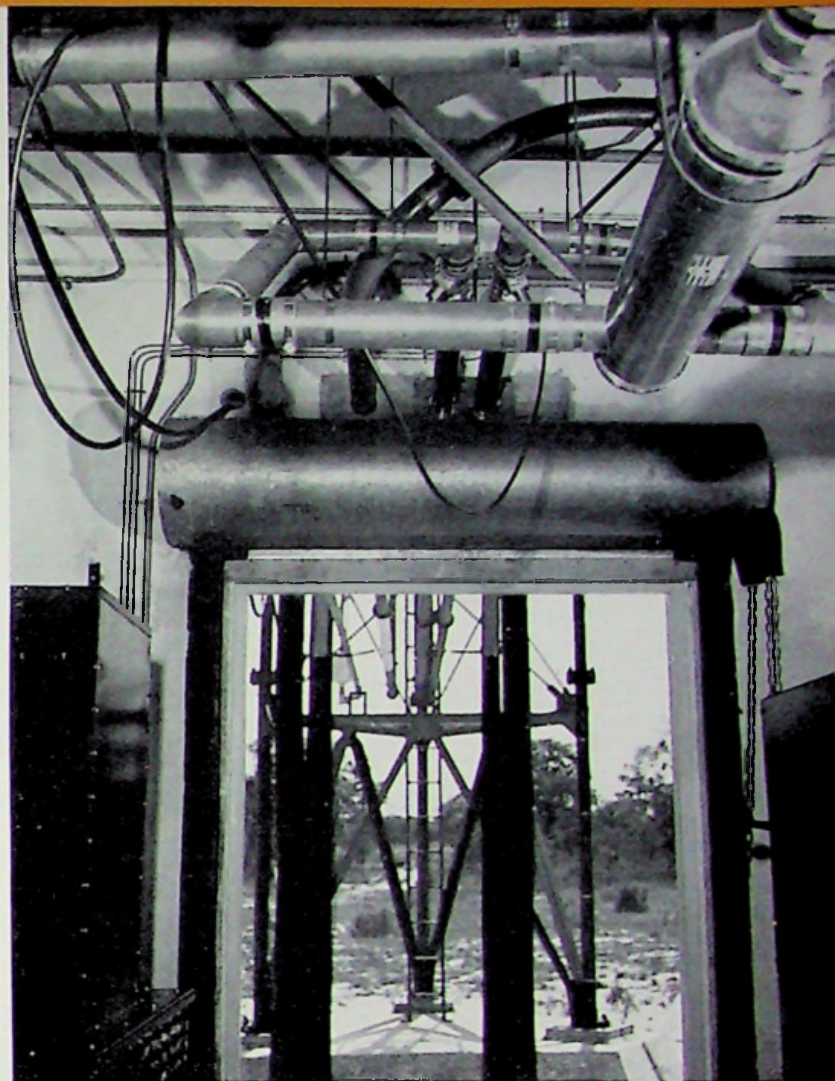

INSTALLATION AND LAYOUT OF TRANSMISSION LINES

TYPICAL DUAL LINE INSTALLATION OF VHF TV TRANSMISSION LINE ON TOWER

Refer to Table Below for Symbol Designations

SYMBOL	DESCRIPTION	1 5/8 DIA. MI NO.	3 1/8 DIA. STEATITE	6 1/8 DIA. MI NO.
A	TRANSMISSION LINE	19112-1	19113-B-1	19314-C-1C
B	90° ELBOW	19112-2	19113-C-18	19314-C-18
C	REDUCER 3 1/8 TO 1 5/8	19112-6	19113-C-6	
C	REDUCER 6 1/8 TO 3 1/8			19314-C-4
D	GAS STOP	19112-5	19113-C-5	19314-C-52
E	ADAPTER	19112-4	19113-C-4	19314-C-4
F	GASSING ACCESSORIES	19112-12	19113-C-12	19112-12
G	FIXED HANGER	19112-15	19113-15	
H	SPRING HANGER	19112-14	19113-14	
J	LATERAL BRACE	19312-36	19313-36	19314-36
K	HORIZONTAL ANCHOR	19312-18	19313-18	19314-19
M	ROLLER ASSEMBLY	19312-35	19313-35	19314-35
N	SWIVAL HANGER	19312-38	19313-38	
P	45° ELBOW	19112-3	19113-C-22	19314-C-22
R	DEHYDRATOR		ON APPLICATION	

WHEN SHAPE OF TOWER CHANGES ADD HANGER SUPPORTS TO TOWER THE FOLLOWING BENDS ARE MAX. 12" BEND FOR 20' SECTION 1 5/8 LINE

6" BEND FOR 20' SECTION 3 1/8 LINE

1" BEND FOR 20' SECTION 6 1/8 LINE

INSTALL VERTICAL LINE SECTIONS WITH ROLLED GROOVES AT LOWER END TO SUPPORT INNER CONDUCTOR

SPACE SPRING HANGERS APPROX. 10 FEET APART

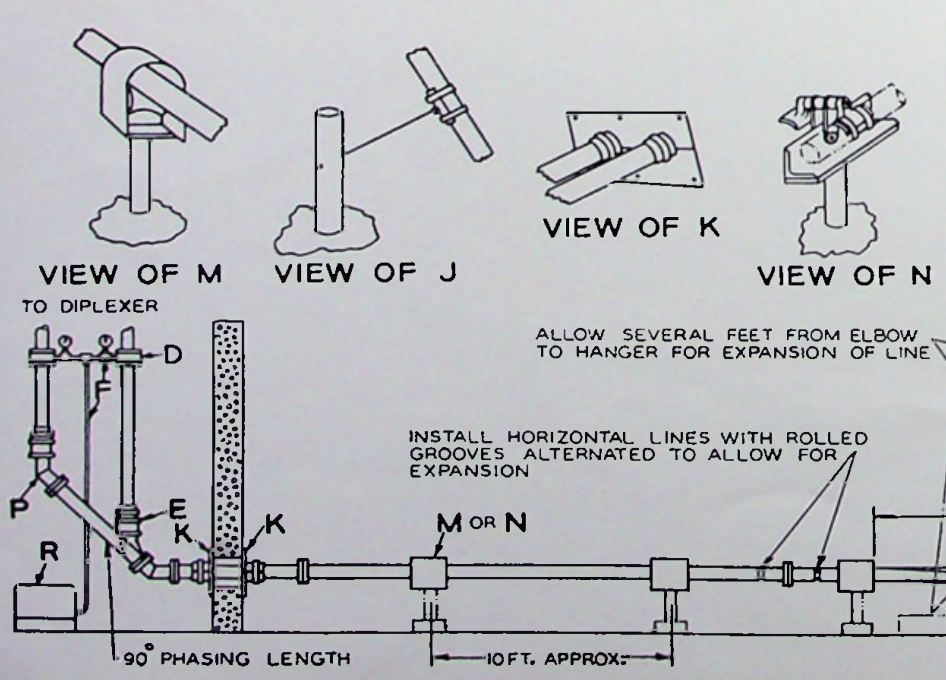
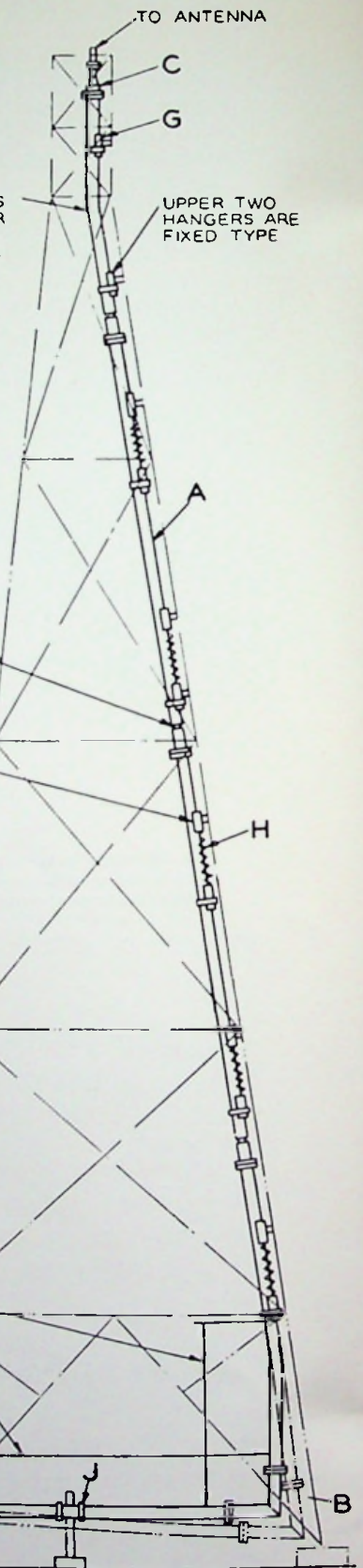

TV TRANSMISSION LINE HANGERS

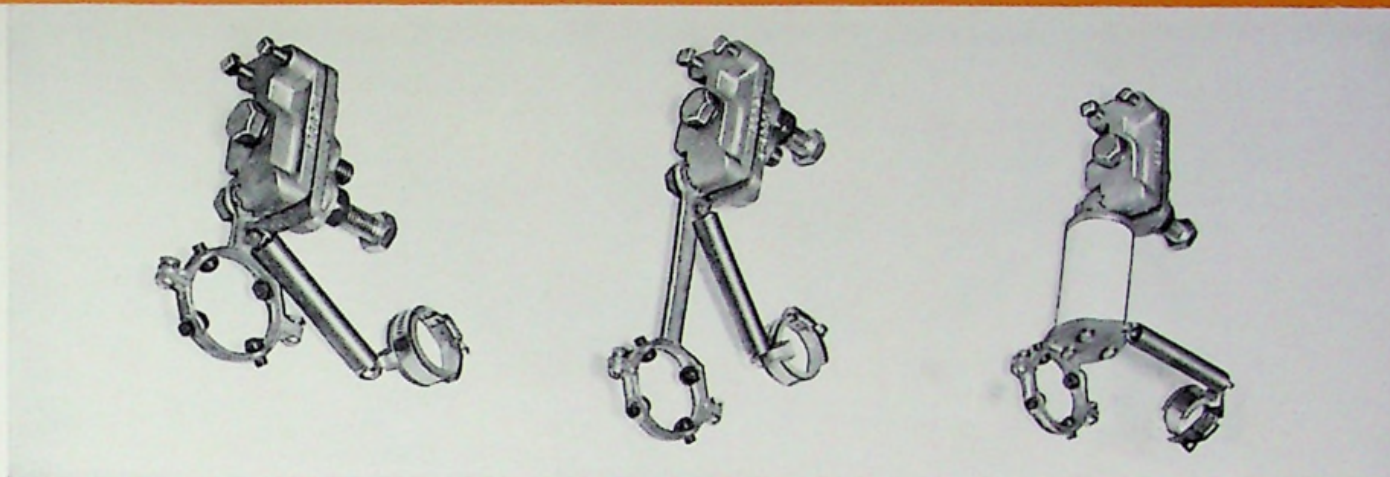

FEATURES

- Hangers available for any Television transmission line mounting requirements
- Designed for maximum ease of installation
- Materials used for construction resist deterioration from weather
- Sturdy rugged construction assures permanent, reliable installation
- Other accessories such as horizontal roller supports, horizontal anchors, lateral braces, indoor hanger kits, etc., afford a complete "matched" installation

USES

RCA's complete line of Television Transmission Line Hangers offers maximum flexibility, efficiency and economy in meeting modern needs in supporting transmission line runs whether on the tower or in the horizontal run from transmitter to tower. Installation engineers have carefully selected a representative line of fixed and expansion type hangers including special miscellaneous type accessories and convenient indoor mounting kits needed for a workable and versatile transmission system.

Hangers are available for any television transmission line mounting requirement of either VHF or UHF broadcast stations. The hangers are designed for maximum ease of installation, and all materials used for construction resist deterioration from weather conditions. Their sturdy, rugged construction assures permanent, reliable installation.

DESCRIPTION

RCA has a complete line of hangers designed for 1 $\frac{5}{8}$ "", 3 $\frac{1}{8}$ "", 6 $\frac{1}{8}$ " and 9 $\frac{3}{16}$ " diameter TV transmission lines. There are hangers for mounting both single and dual lines either vertically or horizontally to flat members, pipes, or angular members. These hangers consist of several general types, i.e., spring suspended expansion hangers (which permit differential thermal expansion of the line and tower), swivel hangers which provide for either horizontal or vertical mounting of the line, and lateral braces and direct mounting anchors. Of these there are short hangers for close mounting, long hangers to provide additional clearance, and insulated as well as noninsulated types. The direct mounting type of hanger requires drilling of a hole in the mounting surface, but no drilling is required for the other types.

FIXED HANGERS FOR SINGLE LINE



(CLAMP ON ROUND MEMBERS)

- MI-19312-41-1 $\frac{5}{8}$
- MI-19312-42-3 $\frac{1}{8}$
- MI-19313-41-3 $\frac{1}{8}$
- MI-19313-42-3 $\frac{1}{8}$



(MOUNT THROUGH HOLE)

- MI-19314-44-6 $\frac{1}{8}$
- MI-27900-44-9 $\frac{3}{8}$



(MOUNT THROUGH HOLE)

- MI-19312-44-1 $\frac{5}{8}$
- MI-19312-47-1 $\frac{5}{8}$
- MI-19313-44-3 $\frac{1}{8}$
- MI-19313-47-3 $\frac{1}{8}$



(CLAMP ON ANGULAR MEMBERS)

- MI-19312-43-1 $\frac{5}{8}$
- MI-19313-43-3 $\frac{1}{8}$



(CLAMP ON FLAT MEMBERS)

- MI-19312-40-1 $\frac{5}{8}$
- MI-19313-40-3 $\frac{1}{8}$

FIXED HANGERS FOR DUAL LINES



(MOUNT THROUGH HOLE)

- MI-19112-15-1 $\frac{5}{8}$
- MI-19113-15-3 $\frac{1}{8}$

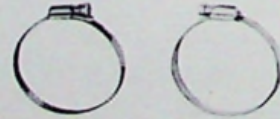

(MOUNT THROUGH HOLE)

- MI-19112-49-1 $\frac{5}{8}$
- MI-19113-49-3 $\frac{1}{8}$



DESCRIPTION (Cont.)

A convenient line of inside hanger kits designed to meet special mounting requirements greatly simplifies indoor station installations. Hanger Kits MI-27700 and MI-27701 are designed for overhead mounting of 3 1/8" and 6 1/8" line respectively. MI-27702 is a bracket type kit for wall mounting of transmission line. Other kits meet special mounting requirements from metal beams, concrete type walls or ceilings, etc.

The instructions supplied with each spring-suspension hanger should be closely followed for proper installation.

The practice is to space the hangers at approximate 10-foot intervals. The line section at the tower top is firmly secured by two fixed hangers, and the lower sections are suspended by spring hangers to allow for differential thermal expansion.

Descriptive information on individual fixed, expansion and miscellaneous type hangers is provided in the following tables where other pertinent information, including ordering information is set forth. Pictures of each type hanger and outline drawing keyed to the tables should be consulted.

DESCRIPTIONS AND SPECIFICATIONS FOR FIXED HANGERS

ITEM	DIMENSIONS (inches)			GROUNDED OR INSULATED	LINE SIZE AND CAPACITY	STOCK IDENTIFICATION
	A	B	C			
<p>FIXED HANGERS, CLAMP ON ROUND MEMBERS</p> <p>For fastening 1 line to round member. Supplied with 1 hose clamp and pivot bolt to compensate for line misalignment. SEE OUTLINE DIMENSION "A"</p>	<p>4 3/8 - 5 5 1/16 - 6 7/16 5 1/8 - 5 3/4 5 13/16 - 7 3/16</p>	<p>1 - 2 1/4 2 1/4 - 5 1 - 2 1/4 2 1/4 - 5</p>		<p>grounded grounded grounded grounded</p>	<p>1 3/8 (1) 1 3/8 (1) 3 1/8 (1) 3 1/8 (1)</p>	<p>MI-19312-41 MI-19312-42 MI-19313-41 MI-19313-42</p>
<p>FIXED HANGERS, MOUNT THROUGH HOLE</p> <p>For direct mounting of 1 line. Requires mounting hole. Mounting bolt and hose clamp supplied. Type with B dimension may be suspended by moving mounting bolt to other hole. SEE OUTLINE DIMENSION "B"</p>	<p>5 3/8 7 3/8</p>		<p>3/8 3/8</p>	<p>grounded grounded</p>	<p>6 1/8 (1) 9 1/8 (1)</p>	<p>MI-19314-44 MI-27900-44</p>
<p>FIXED HANGER, MOUNT THROUGH HOLE</p> <p>For direct mounting. Requires mounting hole. Similar to preceding Type "B" but has pivot bolt to compensate for line misalignment. SEE OUTLINE DIMENSION "C"</p>	<p>3 13/16 7 3/4 4 9/16 8 3/8</p>		<p>3/8 1/2 1/2 1/2</p>	<p>grounded grounded grounded grounded</p>	<p>1 3/8 (1) 1 3/8 (1) 3 1/8 (1) 3 1/8 (1)</p>	<p>MI-19312-44 MI-19312-47 MI-19313-44 MI-19313-47</p>
<p>FIXED HANGER, MOUNT THROUGH HOLE</p> <p>For direct mounting of two lines. Requires mounting hole. Complete with hose clamps. SEE OUTLINE DIMENSION "D"</p>	<p>3 3/4 3 3/4 5 1/2 5 1/2</p>	<p>2 1/2 5 3 1/2 5</p>	<p>1/2 1/2 1/2 1/2</p>	<p>grounded insulated grounded insulated</p>	<p>1 3/8 (2) 1 3/8 (2) 3 1/8 (2) 3 1/8 (2)</p>	<p>MI-19112-15 MI-19112-49 MI-19113-15 MI-19113-49</p>
<p>FIXED HANGERS, CLAMP ON FLAT MEMBER</p> <p>For fastening 1 line to flat members. Uses adjustable vise-like clamp. Pivot bolt compensates for line misalignment. Complete with hose clamp. SEE OUTLINE DIMENSION "E"</p>	<p>4 9/16 5 3/16</p>	<p>adjustable adjustable</p>		<p>grounded grounded</p>	<p>1 3/8 (1) 3 1/8 (1)</p>	<p>MI-19312-40 MI-19313-40</p>
<p>FIXED HANGER, CLAMP ON ANGLE MEMBERS</p> <p>For clamping 1 line to structural angle members. Pivot bolt compensates for line misalignment. Complete with hose clamps. SEE OUTLINE DIMENSION "F"</p>	<p>4 3/4 5 1/2</p>	<p>1 - 7 1 - 7</p>		<p>grounded grounded</p>	<p>1 3/8 (1) 3 1/8 (1)</p>	<p>MI-19312-43 MI-19313-43</p>

EXPANSION HANGERS FOR SINGLE LINE

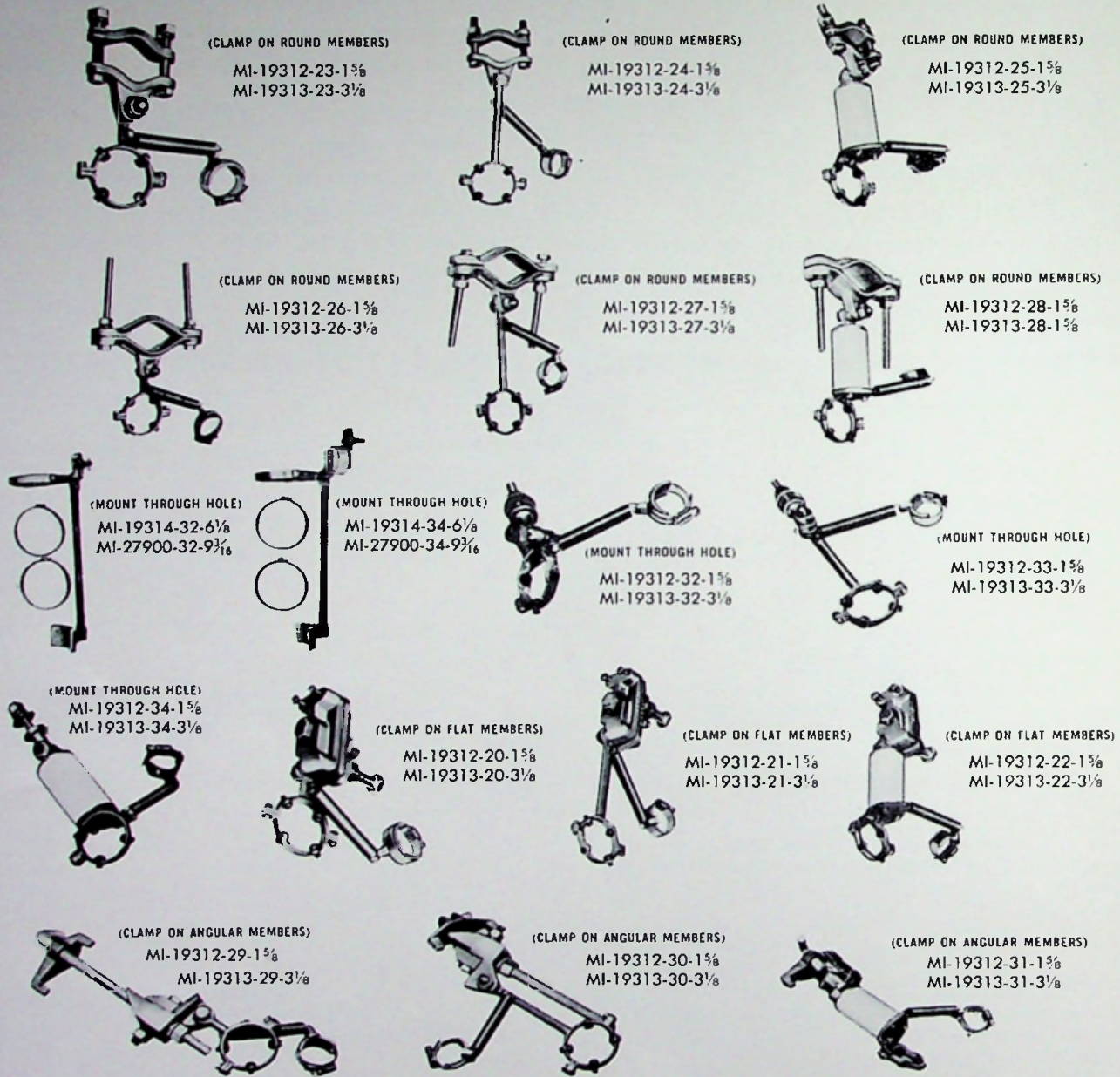

EXPANSION HANGERS FOR DUAL LINES

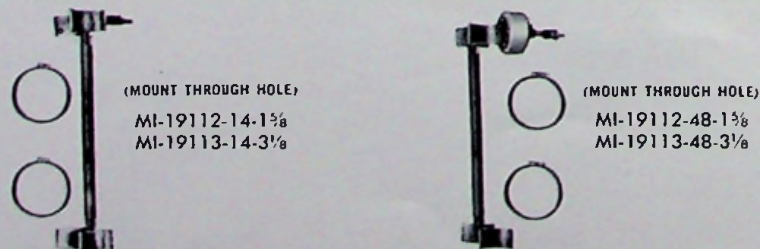

DESCRIPTION AND SPECIFICATIONS FOR EXPANSION HANGERS

ITEM	DIMENSIONS (inches)			GROUNDED OR INSULATED	LINE SIZE AND CAPACITY	RCA REFERENCE NO.
	A	B	C			
<p>EXPANSION HANGERS, CLAMP ON ROUND MEMBERS Spring suspended hanger for clamping single line to round member. Complete with hose clamps and pivot bolt to compensate for line misalignment. Spring must be preloaded at installation. SEE OUTLINE DIMENSION "G"</p>	4 3/8 - 5	1 - 2 1/4		grounded	1 3/8 (1)	MI-19312-23
	7 7/8 - 8 1/2	1 - 2 1/4		grounded	1 3/8 (1)	MI-19312-24
	5 1/8 - 6 3/8	2 1/4 - 5		grounded	1 3/8 (1)	MI-19312-26
	8 3/8 - 9 1 3/8	2 1/4 - 5		grounded	1 3/8 (1)	MI-19312-27
	8 1 1/8 - 9 5/8	1 - 2 1/4		insulated	1 3/8 (1)	MI-19312-25
	8 3/8 - 9 1 3/8	2 1/4 - 5		insulated	1 3/8 (1)	MI-19312-28
	5 1/8 - 5 3/4	1 - 2 1/4		grounded	3 3/8 (1)	MI-19313-23
	8 1 1/8 - 9 5/8	1 - 2 1/4		grounded	3 3/8 (1)	MI-19313-24
	5 1 3/8 - 7 3/8	2 1/4 - 5		grounded	3 3/8 (1)	MI-19313-26
	9 3/8 - 10 3/4	2 1/4 - 5		grounded	3 3/8 (1)	MI-19313-27
	8 1 1/8 - 9 5/8	1 - 2 1/4		insulated	3 3/8 (1)	MI-19313-25
	9 3/8 - 10 3/4	2 1/4 - 5		insulated	3 3/8 (1)	MI-19313-28
	<p>EXPANSION HANGERS, MOUNT THROUGH HOLE Spring-suspended hanger for mounting through single hole. Complete with hose clamp. Spring must be preloaded at installation. SEE OUTLINE DIMENSION "H"</p>	5 3/8	1" max.	3/8	grounded	6 3/8 (1)
6 3/8		1" max.	3/8	grounded	9 3/8 (1)	MI-27900-32
8 1/8		1" max.	3/8	insulated	6 3/8 (1)	MI-19314-34
11 3/8		1" max.	1/2	insulated	9 3/8 (1)	MI-27900-34
<p>EXPANSION HANGERS, MOUNT THROUGH HOLE Spring-suspended for mounting through single hole. Similar to preceding type "H" but has pivot bolt to compensate for line misalignment. Spring must be preloaded at installation. SEE OUTLINE DIMENSION "I"</p>	4 1/4		1/2	grounded	1 3/8 (1)	MI-19312-32
	7 3/4		1/2	grounded	1 3/8 (1)	MI-19312-33
	7 3/4		1/2	insulated	1 3/8 (1)	MI-19312-34
	5		1/2	grounded	3 3/8 (1)	MI-19313-32
	8 3/8		1/2	grounded	3 3/8 (1)	MI-19313-33
	8 3/8		1/2	insulated	3 3/8 (1)	MI-19313-34
<p>EXPANSION HANGERS, MOUNT THROUGH HOLE For spring-suspension of two lines. Requires mounting hole. Complete with hose clamps. Spring preloaded at installation. SEE OUTLINE DIMENSION "J"</p>	3 3/4	2 3/32	1/2	grounded	1 3/8 (2)	MI-19112-14
	3 3/4	5	1/2	insulated	1 3/8 (2)	MI-19112-48
	5 1/2	3 3/8	1/2	grounded	3 3/8 (2)	MI-19113-14
	5 1/2	5	1/2	insulated	3 3/8 (2)	MI-19113-48
<p>EXPANSION HANGERS, CLAMP ON FLAT MEMBERS Spring-suspended hanger for fastening 1 line to flat members. Uses adjustable vise-like clamp. Pivot bolt compensates for line misalignment. Complete with hose clamp. Spring must be preloaded at installation. SEE OUTLINE DIMENSION "K"</p>	4 3/8			grounded	1 3/8 (1)	MI-19312-20
	8 1/8			grounded	1 3/8 (1)	MI-19312-21
	8 3/8			insulated	1 3/8 (1)	MI-19312-22
	5 3/8			grounded	3 3/8 (1)	MI-19313-20
	8 3/8			grounded	3 3/8 (1)	MI-19313-21
	8 3/8			insulated	3 3/8 (1)	MI-19313-22
<p>EXPANSION HANGERS, CLAMP ON ANGLE MEMBERS Spring-suspended hanger for clamping 1 line to structural angles. Pivot bolt compensates for line misalignment. Complete with hose clamp. Spring must be preloaded at installation. SEE OUTLINE DIMENSION "L"</p>	4 3/4	7" max.		grounded	1 3/8 (1)	MI-19312-29
	8 1/4	7" max.		grounded	1 3/8 (1)	MI-19312-30
	8 1/4	7" max.		insulated	1 3/8 (1)	MI-19312-31
	5 1/2	7" max.		grounded	3 3/8 (1)	MI-19313-29
	9 1/8	7" max.		grounded	3 3/8 (1)	MI-19313-30
	9 1/8	7" max.		insulated	3 3/8 (1)	MI-19313-31
<p>EXPANSION HANGERS, SPECIAL 3-POINT SPRING SUSPENSION See under Miscellaneous Accessories.</p>						

MISCELLANEOUS ACCESSORIES

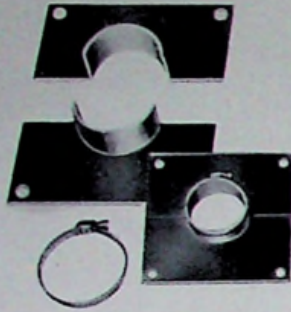

HORIZONTAL ANCHOR FOR SUPPORTING SINGLE LINE
 MI-19312-17-1 $\frac{5}{8}$
 MI-19313-17-3 $\frac{3}{8}$
 MI-19314-48-6 $\frac{1}{8}$
 MI-27900-48-9 $\frac{3}{16}$

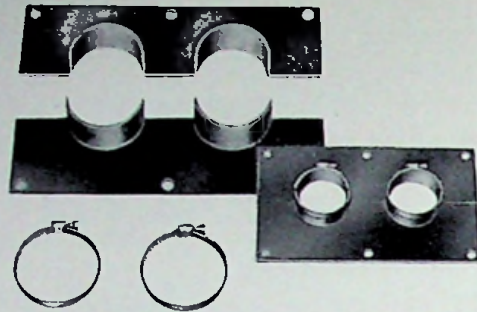

HORIZONTAL ANCHOR FOR SUPPORTING DUAL LINES
 MI-19312-18-1 $\frac{5}{8}$
 MI-19313-18-3 $\frac{3}{8}$
 MI-19314-49-6 $\frac{1}{8}$
 MI-27900-49-9 $\frac{3}{16}$

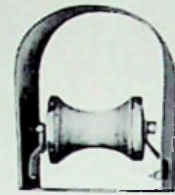

HORIZONTAL ROLLER ASSEMBLY
 MI-19312-35-1 $\frac{5}{8}$
 MI-19313-35-3 $\frac{3}{8}$
 MI-19314-35-6 $\frac{1}{8}$
 MI-27900-35-9 $\frac{3}{16}$

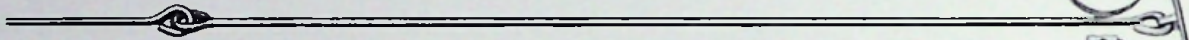

LATERAL BRACE
 MI-19312-36-1 $\frac{5}{8}$
 MI-19313-36-3 $\frac{3}{8}$
 MI-19314-36-6 $\frac{1}{8}$
 MI-27900-36-9 $\frac{3}{16}$

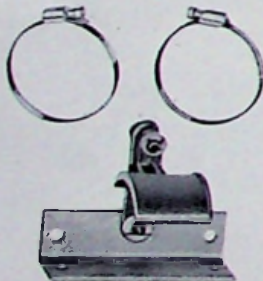

SWIVEL HANGER FOR SUPPORTING SINGLE LINE
 MI-19312-37-1 $\frac{5}{8}$
 MI-19313-37-3 $\frac{3}{8}$



SWIVEL HANGER FOR SUPPORTING DUAL LINES
 MI-19312-38-1 $\frac{5}{8}$
 MI-19313-38-3 $\frac{3}{8}$



LINE SPREADER
 MI-19312-19-1 $\frac{5}{8}$
 MI-19313-19-3 $\frac{3}{8}$



THREE-POINT EXPANSION HANGER FOR SINGLE LINE
 MI-19314-50-6 $\frac{1}{8}$
 MI-27900-50-9 $\frac{3}{16}$

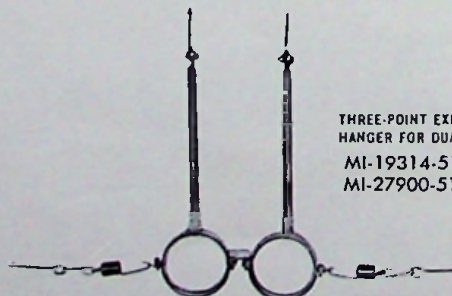

THREE-POINT EXPANSION HANGER FOR DUAL LINES
 MI-19314-51-6 $\frac{1}{8}$
 MI-27900-51-9 $\frac{3}{16}$

DESCRIPTIONS AND SPECIFICATIONS FOR MISCELLANEOUS ACCESSORIES

ITEM	DIMENSIONS (inches)						GROUNDED OR INSULATED	LINE SIZE AND CAPACITY	RCA REFERENCE NO.
	A	B	C	D	E	F			
HORIZONTAL ANCHOR, SINGLE Supports single line at point of entry through a wall. Furnished split in 2 pieces to facilitate installation. Hose clamp anchors line. One anchor required on each side of wall. Mounting bolts not supplied. SEE OUTLINE DIMENSION "M"	6 8 11 3/4 16	4 3/8 6 3/8 10 1/4 8	3 4 5 1/8 6 3/4	3/16 1/8 3/4 1 1/4			grounded grounded grounded grounded	1 3/8 (1) 3 1/8 (1) 6 1/8 (1) 9 3/8 (1)	MI-19312-17 MI-19313-17 MI-19314-48 MI-27900-48
HORIZONTAL ANCHOR, DUAL Same as Type "M" except supports 2 lines. SEE OUTLINE DIMENSION "N"	9 3/4 13 1/2 20 1/2 28	6 8 11 3/4 16	8 3/8 12 3/8 19 25 1/2	4 7/8 6 7/8 10 1/4 13 1/2	4 3/16 6 1/16 9 1/2 12 3/4	3 3/4 5 1/2 8 3/4 12 1/2	grounded grounded grounded grounded	1 3/8 (2) 3 1/8 (2) 6 1/8 (2) 9 3/8 (2)	MI-19312-18 MI-19313-18 MI-19314-49 MI-27900-49
HORIZONTAL ROLLER ASSEMBLY For supporting single horizontal line. Revolving roller permits line expansion. Hood protects roller. Dual lines require two assemblies. Mounting bolts not furnished. SEE OUTLINE DIMENSION "O"	2 1/16 5 3/16 7 7/8 10 3/8	1 13/16 3 5 1/2 7 1/4	3 1/16 4 3/4 8 11 5/8	6 8 12 20			grounded grounded grounded grounded	1 3/8 (1) 3 1/8 (1) 6 1/8 (1) 9 3/8 (1)	MI-19312-35 MI-19313-35 MI-19314-35 MI-27900-35
LATERAL BRACE For maintaining single line at fixed distance from tower or building. Mounts through single hole. Complete with two hose clamps. SEE OUTLINE DIMENSION "P"	8 8 7 3/4 7 3/4	38 1/2 38 1/2 38 3/4 38 3/4	1/2 1/2 3/8 3/8				grounded grounded grounded grounded	1 3/8 (1) 3 1/8 (1) 6 1/8 (1) 9 3/8 (1)	MI-19312-36 MI-19313-36 MI-19314-36 MI-27900-36
LINE SPREADER For maintaining spacing between two lines. Asbestos-lined surfaces hold lines without scoring. Two hose clamps supplied. SEE OUTLINE DIMENSION "Q"	3 3/4 5 1/2							1 3/8 (2) 3 1/8 (2)	MI-19312-19 MI-19313-19
SWIVEL HANGERS For use in horizontal runs to accommodate uneven terrain or line misalignment. Will also take care of some line expansion. Angle support may be mounted horizontally or vertically. Angle support pivots on one pin and support, casting pivots on another pin. For single or dual lines, as noted. Complete with hose clamps. SEE OUTLINE DIMENSION "R"	— 3 3/4 — 6 1/2	2 1/32 2 1/32 2 1/32 2 1/32	1 1/8 1 1/8 1 1/8 1 1/8	5 5 5 5	3/32 3/32 7/16 7/16	1/2 1/2 1/2 1/2	grounded grounded grounded grounded	1 3/8 (1) 1 3/8 (2) 3 1/8 (1) 3 1/8 (2)	MI-19312-37 MI-19312-38 MI-19313-37 MI-19313-38
3-POINT EXPANSION HANGER, SINGLE For horizontal suspension of single line. Fastened at three points with eye bolts and springs. SEE OUTLINE DIMENSION "S"	28 29 1/2	16 3/4 18 3/8					grounded grounded	6 1/8 (1) 9 3/8 (1)	MI-19314-50 MI-27900-50
3-POINT EXPANSION HANGER, DUAL Same as Type "S" but accommodates 2 lines. SEE OUTLINE DIMENSION "T"	28 29 1/2	16 3/4 18 3/8	8 3/4 14				grounded grounded	6 1/8 (2) 9 3/8 (2)	MI-19314-51 MI-27900-51
EXTENSION KIT Extends the mounting of grounded dual hangers to align with insulated dual hangers. SEE OUTLINE DIMENSION "U"	4 1/2	7 1/2	1/2						MI-19113-16

OUTLINE DIMENSIONS OF FIXED AND EXPANSION HANGERS

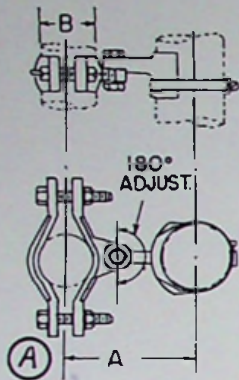

(WITH PIVOT. CLAMP ON ROUND MEMBERS)

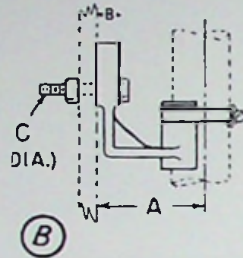

(MOUNT THROUGH HOLE)

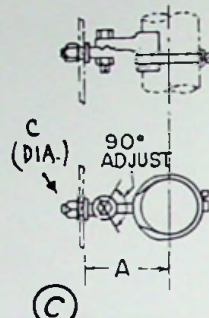

(WITH PIVOT. MOUNT THROUGH HOLE)

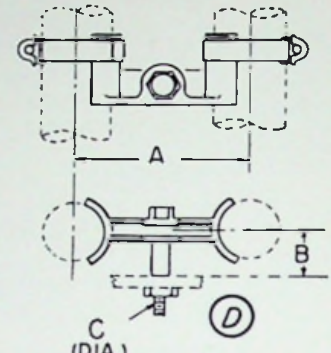

(MOUNT THROUGH HOLE)

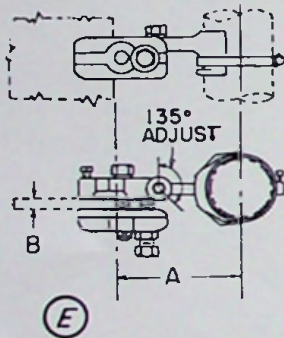

(WITH PIVOT. CLAMP ON FLAT MEMBERS)

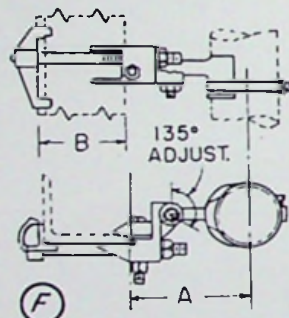

(WITH PIVOT. CLAMP ON ANGLES)

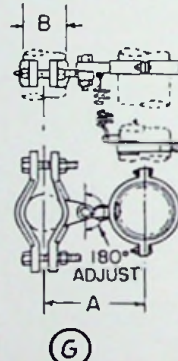

(WITH PIVOT. CLAMP ON ROUND MEMBERS)

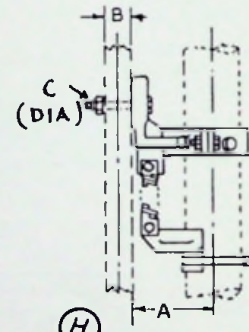

(MOUNT THROUGH HOLE)

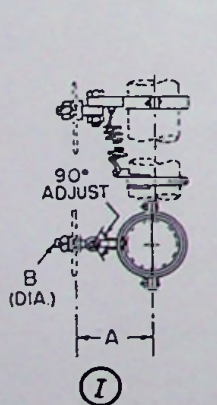

(WITH PIVOT. MOUNT THROUGH HOLE)

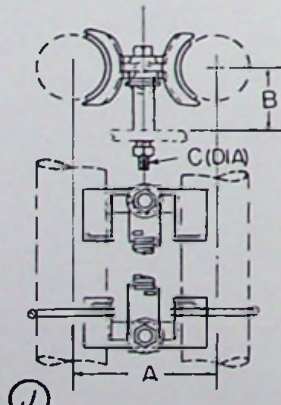

(MOUNT THROUGH HOLE)

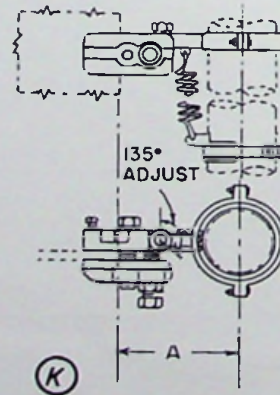

(WITH PIVOT. CLAMP ON FLAT MEMBERS)

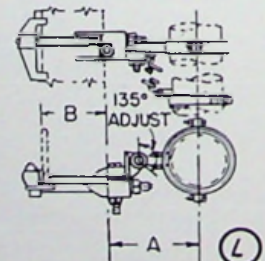

(WITH PIVOT. CLAMP ON ANGLES)

OUTLINE DIMENSIONS OF MISCELLANEOUS ACCESSORIES

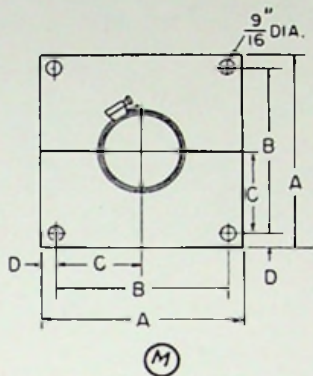

(HORIZONTAL ANCHOR, SINGLE)

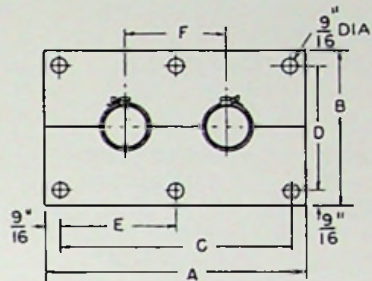

(HORIZONTAL ANCHOR, DUAL)

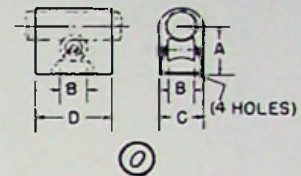

(HORIZONTAL ROLLER ASSY.)

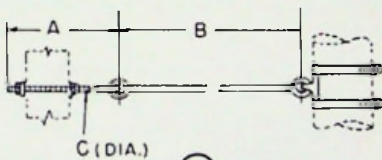

(LATERAL BRACE)

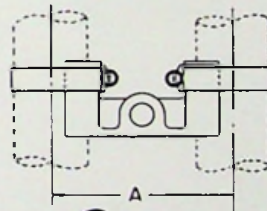

(LINE SPREADER)

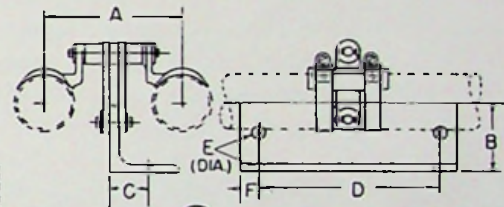

(SWIVEL HANGERS)

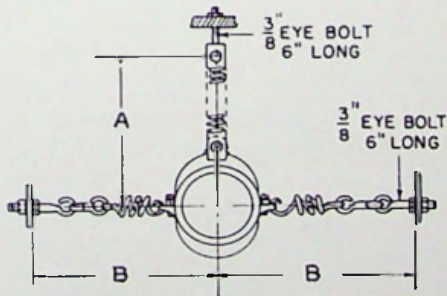

(3-POINT HANGER, SINGLE)

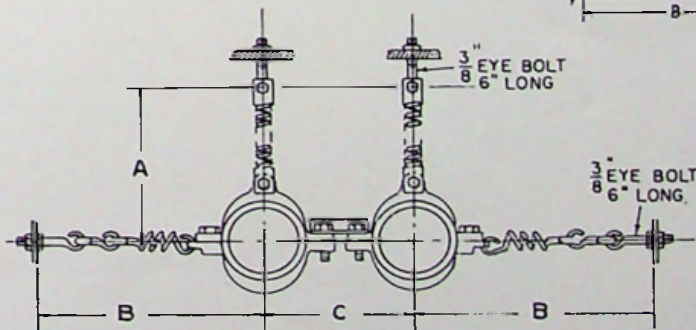

(3-POINT HANGER, DUAL)

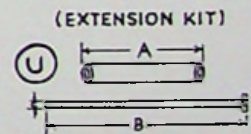

(EXTENSION KIT)

RCA SPECIAL INDOOR HANGER KITS

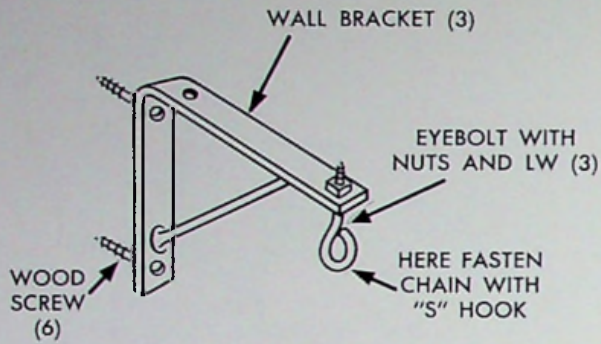

MI-27702 FOR 3/8" & 6/8"

BOLT WITH NUT AND LW (6) (FASTEN TO WALL BKT)

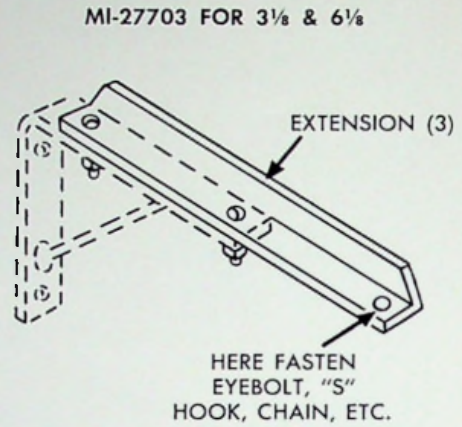

MI-27703 FOR 3/8" & 6/8"

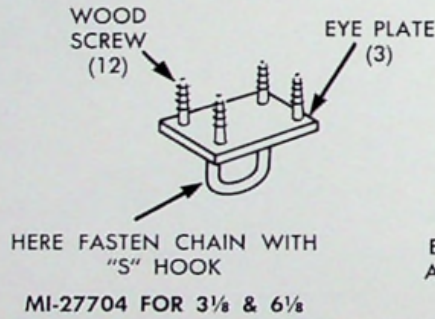
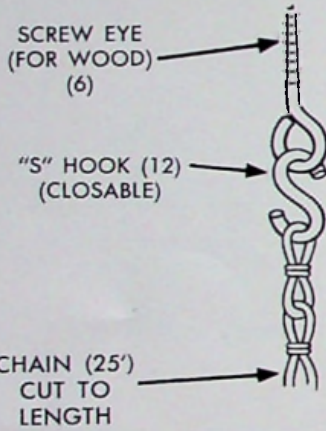

MI-27704 FOR 3/8" & 6/8"

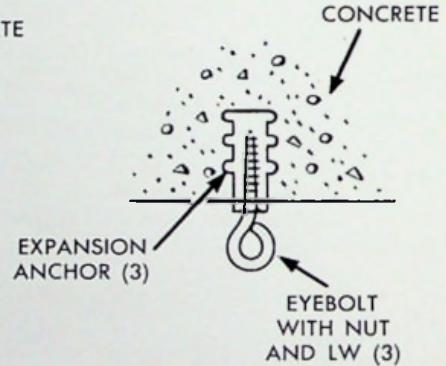

MI-27706 FOR 3/8" & 6/8"

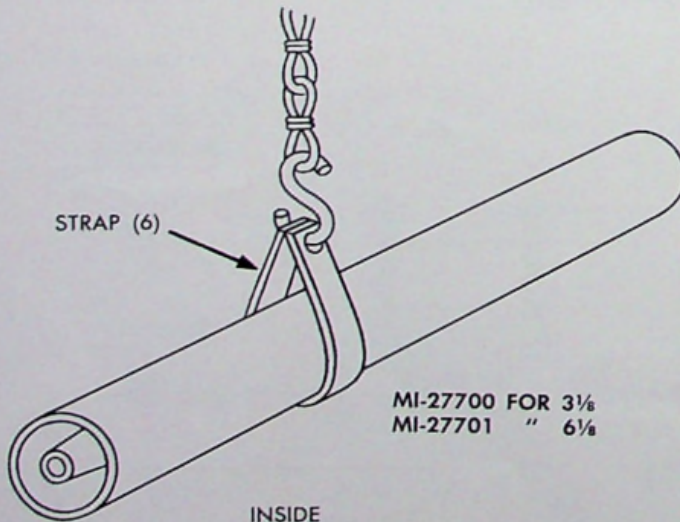

MI-27700 FOR 3/8" MI-27701 " 6/8"

INSIDE HANGERS AND VARIOUS FASTENERS

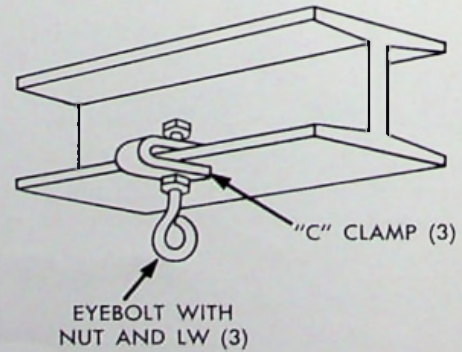

MI-27705 FOR 3/8" & 6/8"

DESCRIPTIONS AND SPECIFICATIONS FOR RCA SPECIAL INDOOR HANGER KITS

ITEM	LINE SIZE AND CAPACITY	STOCK IDENTIFICATION
Inside Hanger Kit for 3 1/8" Line, attaches to line for ceiling support. Kit consists of stainless steel straps, 25-feet of chain and mounting hardware suitable for supporting line at six points. Tensile strength of chain 260 pounds.	3 1/8"	MI-27700
Inside Hanger Kit for 6 1/8" Line, same as MI-27700 Kit except suitable for supporting larger transmission line.	6 1/8"	MI-27701
Inside Hanger Wall Bracket Kit, for supporting line from wall of building. Kit contains three heavy duty brackets 1 1/2" wide with 7 1/2" arms and mounting hardware for supporting line at three points.	3 1/8" or 6 1/8"	MI-27702
Inside Wall Bracket Extension Kit, containing three heavy duty angle extensions and hardware for use with MI-27702 to extend line out from wall of building. Extension angles are 12" long, 1/8" thick and 1 1/4" x 1 1/4" on side.	3 1/8" or 6 1/8"	MI-27703
Inside Hanger Plate Mounting Kit, for attaching MI-27700 or MI-27701 to plaster or wood surface. Contains three steel eye plates and mounting hardware sufficient for three supporting points.	3 1/8" or 6 1/8"	MI-27704
Inside Hanger "I" Beam Mounting Kit, consisting of hardware for attaching MI-27700 or MI-27701 to "I" beam at three supporting points.	3 1/8" or 6 1/8"	MI-27705
Inside Hanger Concrete Mounting Kit, consisting of eye bolts and expansion anchors suitable for attaching to concrete wall or ceiling MI-27700 or MI-27701 at three supporting points.	3 1/8" or 6 1/8"	MI-27706

HANGER INSTALLATION DATA

Due to the many precautions that surround transmission line installations, its assembly should be entrusted to only the most competent engineers. In using RCA fixed and expansion type hangers for single and dual runs, RCA engineers are prepared to recommend proper types for all horizontal or tower installations. The following tables on differential expansion should be taken into consideration when installing VHF or UHF transmission line.

Differential expansion between line and tower is accommodated by suspending the line from spring hangers within the tower. Two hangers at the top of the tower are fixed so that the line cannot move vertically through them. The rest of the hangers are of the spring type which permit the line to move vertically. Each hanger exerts an upward force equal to the weight of ten feet of line. The hangers are spaced at approximately ten foot intervals and hence there is no tension on the line under the average temperature condition. The line moves upward or downward in the hangers as differential expansion takes place. At the tower base the vertical movement is permitted to deflect the horizontal run as expansion takes place. In a similar manner movement of the horizontal run from the transmitter building to tower deflects the bottom few feet of the line in the tower. The amount of deflection that is permissible is limited to values which will not cause mechanical change to the line or result in change in impedance. Bending in the line should be limited to 6 inches in 20 feet for 3 1/8" line, or 1 inch in 20 feet for 6 1/8" line. Sliding type hangers are available to prevent lateral motion of line, and insulated hangers are used when the transmission line feeds an antenna mounted on an AM tower. Isolation

of the transmission line in a tower used for medium frequency broadcasting is accomplished by using insulated hangers in the tower for a distance from the base equal to a quarter wavelength at the medium frequency.

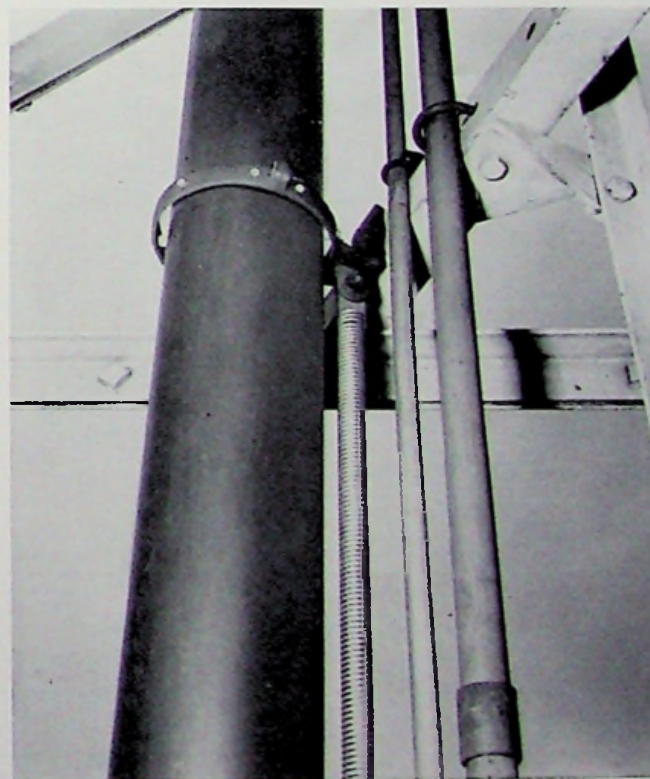

Detail view showing transmission line hangers which secure line to structural members of antenna tower. Expansion type hangers shown above or fixed hangers are most commonly used to assure permanent, reliable installation.

SPRING PRE-LOADING DIMENSIONS FOR EXPANSION HANGERS TYPE C

Hanger Installation Settings for MI-27792 6 1/8" Universal Transmission Line in Inches, 10' Average Spacing.* (For other 6 1/8" lines, increase values 1 inch.)

DISTANCE DOWN FROM LOWEST FIXED HANGER—FT.	AMBIENT TEMPERATURE DEGREES F AT TIME OF INSTALLATION				
	0-20	20-40	40-60	60-80	80-100
0-200	26 1/8	26 1/8	26 1/8	26 1/8	26 1/8
200-400	25 5/8	25 7/8	25 3/4	26 2/3	26 5/8
400-600	25 3/16	25 11/16	25 3/4	26 1/2	26 15/16
600-800	25	25 1/16	25 3/4	26 11/16	27 1/4
800-1000	24 11/16	25 3/8	25 3/4	26 7/8	27 1/16
1000-1200	24 3/8	25 1/4	25 3/4	27	27 1/2
1200-1400	24 1/16	25 1/16	25 3/4	27 1/8	28 3/16
1400-1600	23 3/4	24 13/16	25 3/4	27 5/16	28 1/2

Dimension Taken Over Spring as shown in diagram

* For every 1 ft. difference of average hanger spacing (up to 3 ft.) change the settings by 1/8 inch, adding if the spacing is greater than 10 ft., subtracting if less. Consult RCA for exceptions. (For lines other than MI-27792 Universal type, change setting by 7/8 inch.)

Hanger Installation Settings for MI-27793, 9 3/16" Universal Transmission Line in Inches, 10' Average Spacing.*

DISTANCE DOWN FROM LOWEST FIXED HANGER—FT.	AMBIENT TEMPERATURE DEGREES F AT TIME OF INSTALLATION				
	0-20	20-40	40-60	60-80	80-100
0-200	24 3/4	24 3/4	24 3/4	24 3/4	24 3/4
200-400	24 1/4	24 1/2	24 3/4	25	25 1/4
400-600	23 15/16	24 5/16	24 3/4	25 1/8	25 3/16
600-800	23 5/8	24 3/16	24 3/4	25 5/16	25 7/8
800-1000	23 5/16	24	24 3/4	25 1/2	26 3/16
1000-1200	23	23 7/8	24 3/4	25 5/8	26 1/8
1200-1400	22 11/16	23 11/16	24 3/4	25 3/4	26 13/16
1400-1600	22 3/8	23 5/16	24 3/4	25 15/16	27 1/8

Dimension Taken Over Spring as shown in diagram

* For every 1 ft. difference of average hanger spacing (up to 3 ft.) change the setting by 1/8 inch, adding if the spacing is greater than 10 ft., subtracting if less. Consult RCA for exceptions.

Hanger Installation Settings for MI-19314 or MI-19387, 6 1/8" Single Transmission Lines in Inches, 10' Average Spacing.*

DISTANCE DOWN FROM LOWEST FIXED HANGER—FT.	AMBIENT TEMPERATURE DEGREES F AT TIME OF INSTALLATION				
	0-20	20-40	40-60	60-80	80-100
0-200	26 3/4	26 3/4	26 3/4	26 3/4	26 3/4
200-400	26 1/4	26 1/2	26 3/4	27	27 1/4
400-600	25 15/16	26 5/16	26 3/4	27 1/8	27 1/16
600-800	25 5/8	26 3/16	26 3/4	27 3/16	27 7/8
800-1000	25 5/16	26	26 3/4	27 1/2	28 3/16
1000-1200	25	25 7/8	26 3/4	27 5/8	28 1/8
1200-1400	24 11/16	25 11/16	26 3/4	27 3/4	28 13/16
1400-1600	24 3/8	25 5/16	26 3/4	27 15/16	29 1/8

Dimension Taken Over Spring as shown in diagram

* For every 1 ft. difference of average hanger spacing (up to 3 ft.) change the setting by 7/8 inch, adding if the spacing is greater than 10 ft., subtracting if less. Consult RCA for exceptions.

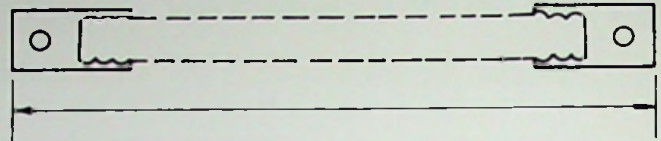

Drawing showing points of measurement used in spring pre-loading tables for RCA expansion hangers. Charts give length in inches.

SPRING PRE-LOADING DIMENSIONS FOR EXPANSION HANGERS TYPE E

Hanger Installation Settings for MI-19112, 1 5/8" Dual Transmission Line in Inches, 10' Average Spacing.*

DISTANCE DOWN FROM LOWEST FIXED HANGER—FT.	AMBIENT TEMPERATURE DEGREES F AT TIME OF INSTALLATION				
	0-20	20-40	40-60	60-80	80-100
0-200	18 5/8	18 5/8	18 5/8	18 5/8	18 5/8
200-400	18 1/8	18 3/8	18 5/8	18 7/8	19 1/8
400-600	17 3/4	18 1/4	18 5/8	19 1/16	19 1/16
600-800	17 7/16	18 1/16	18 5/8	19 3/16	19 3/4
800-1000	17 1/8	17 7/8	18 5/8	19 5/16	20 1/16
1000-1200	16 13/16	17 3/4	18 5/8	19 1/2	20 3/8

Dimension Taken Over Spring as shown in diagram

* For every 1 ft. difference of average hanger spacing, change the setting by 1/8 inch, adding if the spacing is greater than 10 ft., subtracting if less.

Hanger Installation Settings for MI-19113, 3 1/8" Dual Transmission Line in Inches, 10' Average Spacing.*

DISTANCE DOWN FROM LOWEST FIXED HANGER—FT.	AMBIENT TEMPERATURE DEGREES F AT TIME OF INSTALLATION				
	0-20	20-40	40-60	60-80	80-100
0-200	24 3/8	24 3/8	24 3/8	24 3/8	24 3/8
200-400	23 7/8	24 1/8	24 3/8	24 5/8	24 7/8
400-600	23 3/16	23 15/16	24 3/8	24 3/4	25 3/16
600-800	23 1/4	23 13/16	24 3/8	24 15/16	25 1/2
800-1000	22 13/16	23 5/8	24 3/8	25 1/8	25 13/16
1000-1200	22 5/8	23 1/2	24 3/8	25 1/4	26 1/8

Dimension Taken Over Spring as shown in diagram

* For every 1 ft. difference of average hanger spacing, change the setting by 5/8 inch, adding if the spacing is greater than 10 ft., subtracting if less.

SPRING PRE-LOADING DIMENSIONS FOR HANGERS (Outline Types "G," "I," "K," and "L")

ELEVATION AND TEMPERATURE	LINE SIZE	SPRING LENGTH, EXPANDED
All	1 5/8"	8 1/2 inches
All	3 1/8"	24 inches

DEHYDRATORS FOR COAXIAL LINE

MI-27348 SERIES

FEATURES

- Compressor inoperative during most of re-activation period . . . providing economical operation and long life
- Attractive space-saving design
- Completely accessible for quick, easy maintenance
- Simple, rugged construction
- Operates from 115 volt, 60 cycle source
- Convenient arrangement of operation indicating devices
- Choice of single or double desiccants.

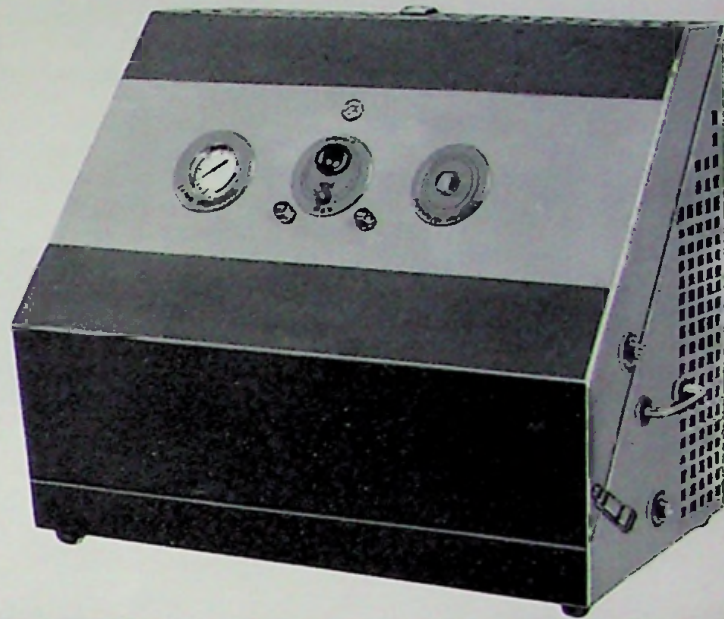

USES

It is extremely important that coaxial transmission lines feeding present day antennas be kept free of moisture. Because of their sectionalized construction, exposure to the effects of weather and temperature, and their comparative inaccessibility for maintenance, they are particularly susceptible to the entry of water, either directly or suspended in vapor drawn in by "breathing" of the line due to temperature change. Moisture in antenna systems can change the loading characteristics of the antenna and set up high standing wave ratios. The danger of arc-over is increased, with possible permanent damage to the antennas which can be corrected only by expensive rigger work and possibly a new antenna system. During sub-zero weather, the freezing water can fracture the lines.

To guard against such danger, all coaxial sections of the system should be pressurized with a moisture-free gas. Because the gas is vapor-free, condensation within the line is avoided, and the pressure acts to prevent the entry of water if small leaks develop. The pressurizing should be done only after the lines have been bled thoroughly and over a number of hours to insure that any trapped moisture has had an opportunity to be assimilated by the gas and discharged from the system.

Either nitrogen or dehydrated air is generally used to keep lines dry. The former may be procured locally in tanks. Special adapters and fittings may be secured from RCA. Except for short runs of line and very pressure tight sys-

tems, the use of nitrogen is awkward and uneconomical. Bleeding a system of re-pressurizing requires a considerable volume of gas and the constant drop in pressure due to even small leaks common to most systems is a constant drain on the source of the gas. As a consequence, the trend is toward the use of dehydrated air. Dehydrated air is obtained through the use of mechanical dehydrators. RCA makes available a wide range of such units.

DESCRIPTION

The RCA MI-27348 Series of Automatic Dehydrator Equipment for coaxial transmission lines provide a choice of single desiccant or double desiccant automatic equipments that operate from a 115 volt, 60 cycle power source. The equipments are attractively housed in space-saving cabinets with sloping panel for control and indicating devices. They are completely accessible for quick, easy maintenance.

The single-desiccant automatic dehydrator automatically reactivates the desiccant according to a set time cycle of operation. Pressure is maintained constant except during reactivation, when no pressure is applied to the line.

The disadvantage of lack of pressure during reactivation time in the above type is overcome in the fully automatic type by the use of two desiccant chambers in conjunction with an electric program timer and solenoid valve arrangement. With this type equipment, pressure is maintained constant at all times and the reactivation is automatic.

1 CFM Single Desiccant Dehydrator

This unit contains a compressor and a single desiccant chamber. A program timer is located on the compressor to stop the compressor after 10 hours of operation. The compressor will operate only when the line pressure falls below a set amount. At the completion of 10 hours of compressor running time, the compressor is turned off by the program timer and a heating unit is turned on and reactivation begins. The heating unit remains on for 5 hours. During the last 1/2 hour of this 5 hour period, the compressor blows air through the desiccant chamber and out to the atmosphere. The compressor is then turned off and the desiccant chamber cools for 5 hours. At the end of this 10 hour period, the compressor is ready to start another 10 hour running cycle. This running period need not be continuous. For example: if the compressor runs 1/2 hour per day, the reactivation cycle will not start for 20 days. A solenoid valve switches the output of the compressor from the line to the atmosphere at the start of the reactivation cycle. This allows the compressor to pass the

air through the desiccant chamber during the last 1/2 hour of the 5 hour heating cycle to the atmosphere rather than the line.

Double Desiccant Dehydrators

These units contains two desiccant chambers. After 10 hours of compressor running time, the output of the compressor is switched from the desiccant chamber being used to the opposite chamber. Reactivation then starts for the chamber previously used. The reactivation cycle is 5 hours heating and 5 hours cooling. During the last 1/2 hour of the heating cycle a solenoid valve opens and allows a portion of the compressor output to pass through the reactivating chamber to the atmosphere. Dry air is available to the line through the desiccant chamber being used at the same time that air is being passed through the reactivating chamber. Solenoid valves control the output of each chamber. These switch the outputs either to the line or to the atmosphere for reactivation or line pressurization.

SPECIFICATIONS

1 cu. ft. Double Desiccant

Power Consumption	900 watts
Compressor Output to Atmosphere.....	1 CFM
Weight	120 lbs.
Drain Connection.....	1/8" female pipe thread
Dew Points	-40° F.
Air Connection.....	Standard Schrader bicycle valve also 15' connecting hose with fittings
Maximum Operating Pressure.....	10 PSI
Serves up to.....	40,000 ft. 7/8" transmission line 10,000 ft. 1 5/8" transmission line 2,500 ft. 3 1/8" transmission line 700 ft. 6 1/8" transmission line
Stock Identification	MI-27348-1

1.5 cu. ft. Double Desiccant

Power Consumption	1700 watts
Compressor Output to Atmosphere.....	1 1/2 CFM
Weight	200 lbs.
Drain Connection.....	1/8" female pipe thread
Dew Points	-40° F.
Air Connection.....	Standard Schrader bicycle valve also 15' connecting hose with fittings
Maximum Operating Pressure.....	10 PSI
Serves up to.....	20,000 ft. 1 5/8" transmission line 5,000 ft. 3 1/8" transmission line 1,500 ft. 6 1/8" transmission line
Stock Identification	MI-27348-2

2 cu. ft. Double Desiccant

Power Consumption.....	2100 watts
Compressor Output to Atmosphere.....	2 CFM
Weight	375 lbs.
Drain Connection.....	1/8" female pipe thread
Dew Points	-40° F.
Air Connection.....	Standard Schrader bicycle valve also 15' connecting hose with fittings
Serves up to.....	40,000 ft. 1 5/8" transmission line 10,000 ft. 3 1/8" transmission line 3,000 ft. 6 1/8" transmission line
Stock Identification	MI-27348-3

1 cu. ft. Single Desiccant

Power Consumption	900 watts
Compressor Output to Atmosphere.....	1 CFM
Weight	100 lbs.
Drain Connection.....	1/8" female pipe thread
Dew Points	-40° F.
Air Connection.....	Standard Schrader bicycle valve also 15' connecting hose with fittings

Maximum Operating Pressure.....	10 PSI
Reactivation Time	10 hours
Serves up to.....	40,000 ft. 7/8" transmission line 10,000 ft. 1 5/8" transmission line 2,500 ft. 3 1/8" transmission line 700 ft. 6 1/8" transmission line
Stock Identification	MI-27348-4

Outline Dimensions of RCA Dehydrators

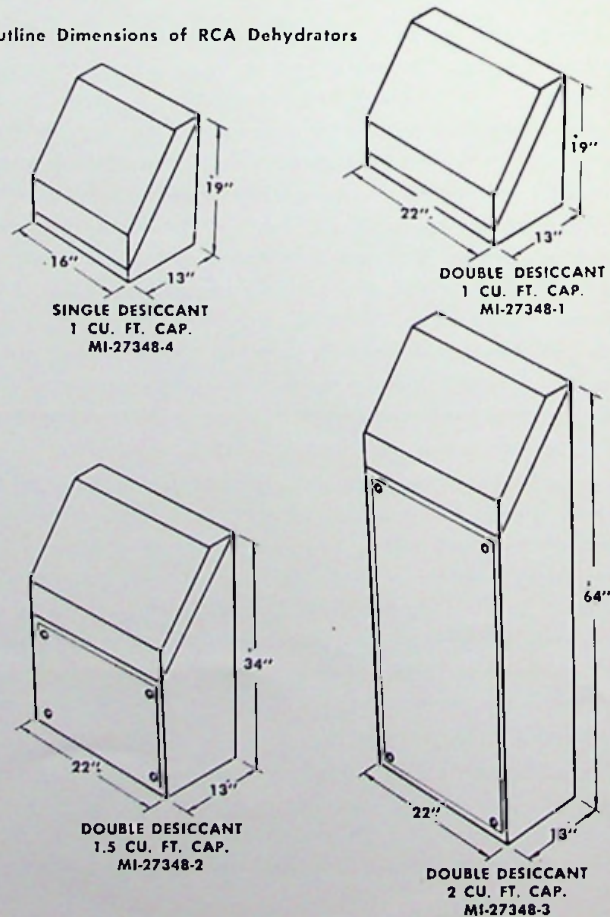

DEHYDRATOR ACCESSORIES

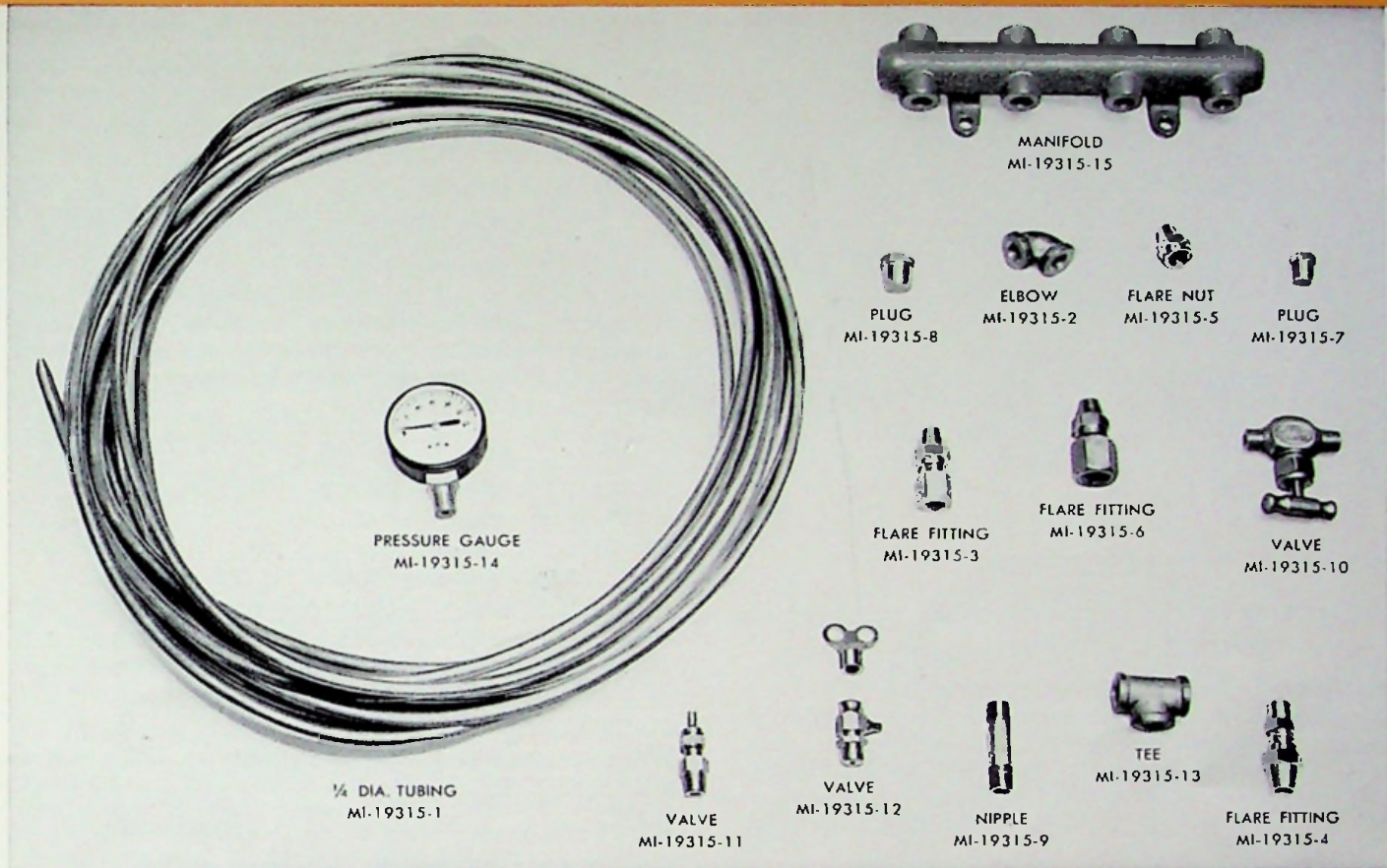

FEATURES

- Assure maximum performance and protection of pressurized TV transmission lines
- Complete line of pressure accessories for use with single, and double desiccant dehydrators or nitrogen gassing
- Feed any number of lines from one source through manifold system
- Highest quality corrosion resistant construction
- Precision gauges for gassed systems
- Packaged kits for standard systems

USES

Line gassing and dehydrator accessories are provided for use with all types of RCA Television Transmission line systems. A wide choice of fittings is available for either VHF or UHF lines incorporating double or single desiccant type dehydrators or bottled nitrogen for line pressurizing. They provide maximum performance and protection of gassed transmission line runs. Each fitting is of highest quality construction and corrosion resistant material.

As a special convenience in ordering for standard station installations, several line gassing accessory kits are available. Kit MI-19112-12 is available for use with a VHF dehydrator system, and Accessory Kit MI-19315-20 is its UHF counterpart. For bottled nitrogen systems, Kit MI-19315-24 is recommended. A choice of single or two stage regulators are offered by RCA for use on nitrogen gassed lines. The two stage regulator gives better regulation as pressure in the nitrogen bottle drops. Manifold MI-19315-15 will prove a convenient means for distributing dry air or gas from one or more sources to several transmission lines.

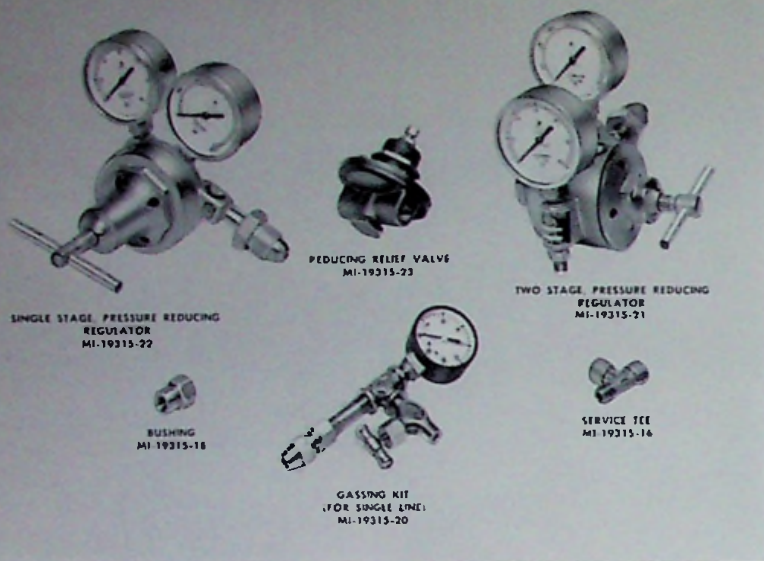

Precision gauges and accessories for gassed systems.

DESCRIPTION

The following accessories are available for air or nitrogen gassed television transmission lines:

MI-19112-12 LINE GASSING ACCESSORIES KIT

Consisting of two pressure indicators, three tee fittings, two needle valves, two elbows, five union nuts, three couplings, and 25-foot coil of type "K" 1/4" O.D. copper tubing. May be used for remotely indicating pressure of two lines fed by one pressure source or two pressure sources feeding one line.

MI-19315-1

1/4" O.D. soft drawn copper tubing. (Furnished in 50-foot coils).

MI-19315-2 FITTING

90° brass elbow. 1/8" x 1/8" IPS.

MI-19315-3 FLARE FITTING

Female for 1/4" soft drawn copper tubing. 1/8" IPS.

MI-19315-4 FLARE FITTING

Male for 1/4" soft drawn copper tubing. 1/8" IPS.

MI-19315-5 NUT

A flare fitting union nut for 1/4" soft drawn copper tubing having a 3/16"-20 thread.

MI-19315-6 FLARE FITTING

Female for 1/4" soft drawn copper tubing to 1/4" IPS.

MI-19315-7 PIPE PLUG

A specially designed brass 1/8" IPS pipe plug.

MI-19315-8 PIPE PLUG

A specially designed brass 1/4" IPS pipe plug.

MI-19315-9 NIPPLE

A brass nipple 1/8" IPS thread x 1 1/2" long.

MI-19315-10 VALVE

A precision needle valve with stainless steel needle stem having 1/8" IPS thread for inlet and outlet. When installing have arrow pointing in direction of air pressure.

MI-19315-11 VALVE

A gas admission valve with removable cap to keep foreign material from entering valve stem. Has 1/8" IPS thread.

MI-19315-12 VALVE

Used as a bleeder valve for bleeding the pressure from line. Furnished with key to open or close valve stem. Has 1/8" IPS thread.

MI-19315-13 TEE FITTING

Brass tee female 1/8" x 1/8" x 1/8" IPS.

MI-19315-14 GAUGE

Used for measuring air or gas pressure up to 30 pounds. Has 1/8" IPS connection. Has glass cover to protect scale.

MI-19315-15 MANIFOLD

Used for distributing dry air or gas from one or more sources to several transmission lines. Has two 1/4" IPS ports in ends of hollow body with eight 1/8" IPS outlets (4 on each side). Plugs may be inserted in unused ports.

MI-19315-16 SERVICE TEE

Similar to MI-19315-13 except one end of tee. Male fitting 1/8" IPS thread.

MI-19315-17 FITTING NIPPLE

1/4" IPS brass nipple, 1 1/2" O.D.

MI-19315-18 BUSHING

Brass, hexagon reducing bushing 1/4" IPS to 1/8" IPS.

MI-19315-20 KIT OF ACCESSORIES

Used to gas a single line and consisting of one each: MI-19315-1, 19315-9, 19315-13, 19315-14, 19315-3, and MI-19315-10.

MI-19315-21 REGULATOR

Two stage pressure reducing regulator for UHF nitrogen gassed lines with 60 lb. and 3000 lb. Airco Standard gauges and having 1/4" half-union take off fitting and 906-14 R.H. thread union nut to fit nitrogen bottle.

MI-19315-22 REGULATOR

Single stage pressure reducing regulator for UHF nitrogen gassed line with 60 lb. and 3000 lb. Airco Standard gauges and 906-14 R.H. thread union nut to fit nitrogen bottle.

MI-19315-23 REDUCING RELIEF VALVE

1/4" IPS inlet and outlet no bleed, soft seat.

MI-19315-24 KIT OF ACCESSORIES

For gassing single line with nitrogen and including one each of MI-19315-1, 19315-3, 19315-5, 19315-10, and 19315-21.

MI-19315-25 UNION FITTING

Flared double ended to join lengths of tubing, 1/4" O.D. threaded 3/16"-20, 1 3/16" long overall.

MI-19315-26 PLAIN PIPE COUPLING

1/8" IPS, 1 3/16" across flats, brass.

MI-19315-27 DEHYDRATOR HOSE

15-foot long 1/2" coupling hose with snap on connectors on each end capable of withstanding 100 lbs. pressure per sq. inch.

MI-19315-28 FLARING AND CUTTING TOOL KIT

Consisting of one flaring tool for 3/16", 1/4", 5/16", 3/8", 7/8", and 1 1/2" O.D. tubing and one tubing cutter for 1/8" to 1" O.D. tubing with extra wheel, contained in a steel tool box. Weight 3 lbs.

VHF AUTOMATIC COAXIAL SWITCHES

MI-27330 & MI-27335

FEATURES

- Motor driven—permits rapid remote-control R-F circuit switching in less than one second
- Useful for power cut-back, emergency transmitter or antenna switching. Avoids time loss common to manual switching systems
- Micro-switches facilitate external position indicating and high voltage interlock circuits for R-F protection during switching cycle
- 30 KW average power rating for all VHF channels

USES

The motor driven VHF coaxial switch is useful for R-F switching in emergency power cut-back systems: switching of standby transmitters or standby antennas; switching between a transmitter and divided antenna with emergency diplexer connections; or other R-F switching systems to meet individual station requirements. An additional function is rapid switching of transmitter outputs or diplexer outputs to permanently mounted R-F load-/wattmeters for maintenance periods or emergency adjustments.

The MI-27330 VHF Automatic Coaxial Switch is designed for use with 51.5 ohm transmission lines such as the RCA types MI-19113 or 19313. The MI-27335 model switch fits the unflanged 50 ohm MI-27912 transmission line.

DESCRIPTION

The Automatic Coaxial Switch is a single-pole, two-position switch for use with 3 1/8" transmission line. The switch consists of a manifold assembly with three parallel branches, the center being the common connection, a motor driven system and its associated limiting switches. This entire assembly is mounted on an aluminum base suitable for mounting in any convenient position.

Switching from one position to another is accomplished by means of a piston rod provided with alternate-conducting and insulated sections that engage conducting sleeves attached to the inner conductors of the three parallel coaxial lines. As this piston moves back and forth, adjacent coaxial lines are either electrically-interconnected or insulated from each other. Means are provided for grounding the particular input connection that is not interconnected. One end

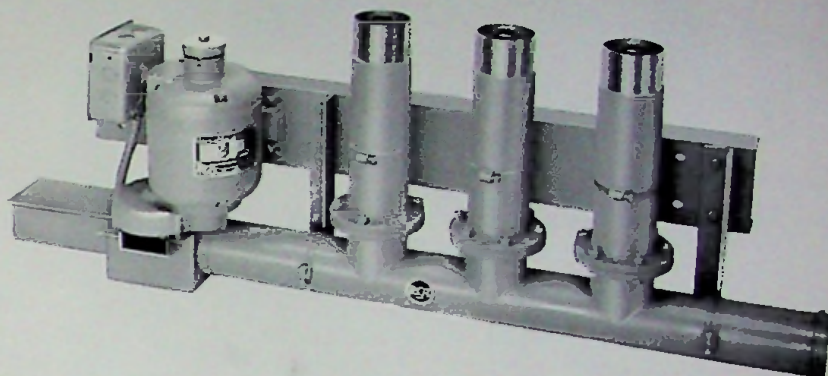

of this piston is connected to a rack which, in turn, engages a pinion gear driven by the motor. Pins mounted on this rack engage micro-switches to control the length of time voltage is applied to the drive motor. A double pole, double throw toggle switch capable of handling 11 amperes at 220 a-c is suitable for controlling the drive motor. Terminals are unflanged. Connection is made to this unflanged line by means of an MI-19313-8 coupling available as an accessory. Maximum VSWR is 1.04 to 1.0 or better at all VHF channels.

Micro-switches are available at each position in order to operate external position indicating devices, such as signal lamps. These micro-switches are also available for operation of power interlock circuits and associated functions such as the shut down of high power amplifiers in power cutback systems. Removal of R-F power is a necessary precaution during operation of the switch. Since the circuitry, control, and indicating devices and their location will vary widely in different applications, these accessory items are not provided with the switch.

SPECIFICATIONS

Mechanical

Weight.....	Approx. 107 lbs.
Length, Overall.....	48"
Width.....	9"
Height.....	16"

Electrical

Impedance.....	51.5 ohms
Maximum VSWR.....	1.04 to 1.0
Power Rating.....	30 kw average
Driving Motor.....	220 v., 1 phase, 60 cycle, 11 amps. locked rotor
Micro-Switch Contacts.....	15 amps. at 125 or 250 v.

Stock Identification:

Coaxial Switch for use with 51.5 Ohm Line.....	MI-27330
Coaxial Switch for use with 50 Ohm Line.....	MI-27335

MANUAL TRANSFER PANELS

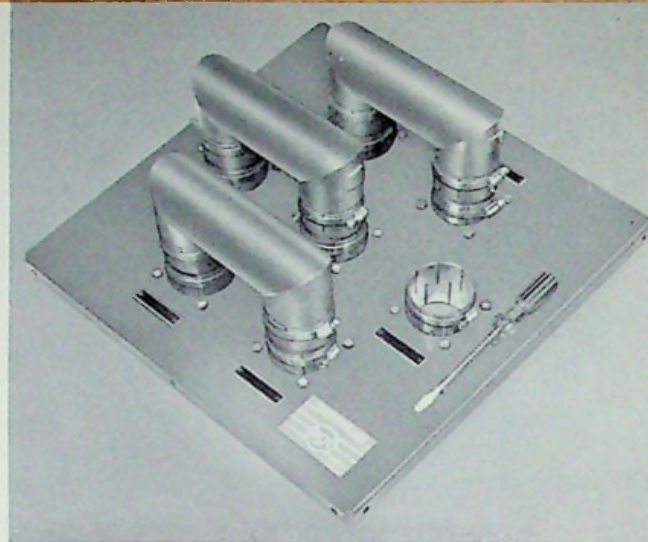
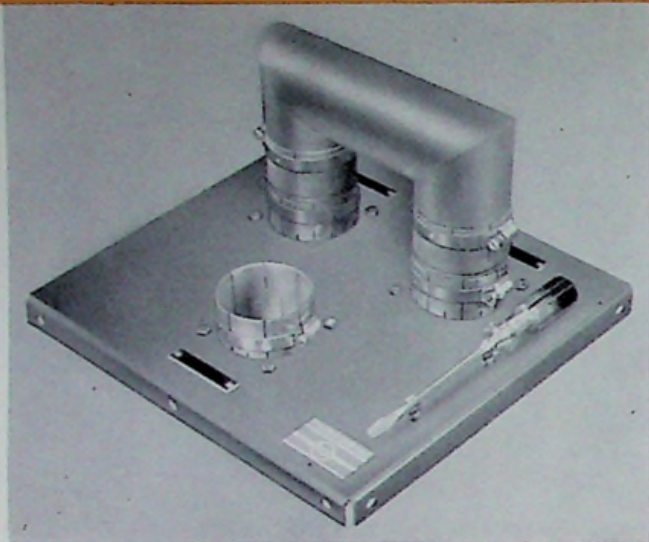

FEATURES

- Sturdy steel panel
- Affords convenient, rapid switching of r-f power circuits
- Completely avoids crosstalk
- Performs functions such as power cutback, dummy load switching, emergency or spare antenna and transmitter switching
- VSWR better than 1.02 to 1

USES

RCA Manual Transfer Panels provide a convenient and rapid means of switching the r-f power circuits which extend between the transmitter and the antenna. Functions such as power cutback, dummy load switching, emergency antenna connections, spare antenna, and spare transmitter switching are readily accomplished by means of these coaxial panels.

Electrically all manual transfer panels are similar, but mechanically they differ in construction to meet the needs of the various sizes and types of transmission lines. The summary table should be consulted for ordering purposes.

Convenient Summary of RCA Type Manual Transfer Panels

Stock Identification	Diameter	Impedance	Pole	Type Connector	For Use with RCA Line
MI-27717	3 1/8"	51.5	3	Sleeve	MI-19113-B or MI-19313
MI-27718	3 1/8"	51.5	7	Sleeve	MI-19113-B or MI-19313
MI-27719	6 1/8"	51.5	3	Sleeve	MI-19314-C
MI-27720	6 1/8"	51.5	7	Sleeve	MI-19314-C
MI-27333	3 1/8"	50	3	Flanged (RETMA) (EIA)	MI-19089
MI-27334	3 1/8"	50	7	Flanged (RETMA) (EIA)	MI-19089
MI-27710	6 1/8"	75	3	Flanged (RETMA) (EIA)	MI-19387
MI-27711	6 1/8"	75	7	Flanged (RETMA) (EIA)	MI-19387
MI-27791-50	3 1/8"	50	3	Clamp Universal	MI-27791
MI-27791-51	3 1/8"	50	7	Clamp Universal	MI-27791
MI-27792-50	6 1/8"	75	3	Clamp Universal	MI-27792
MI-27792-51	6 1/8"	75	7	Clamp Universal	MI-27792
MI-27912-50	3 1/8"	50	3	Inside, Universal	MI-27912
MI-27912-51	3 1/8"	50	7	Inside, Universal	MI-27912

The above are standard designs fitting most requirements. Other configurations to fit special switching requirements are available on special order.

Suggested Uses for Manual Transfer Panels

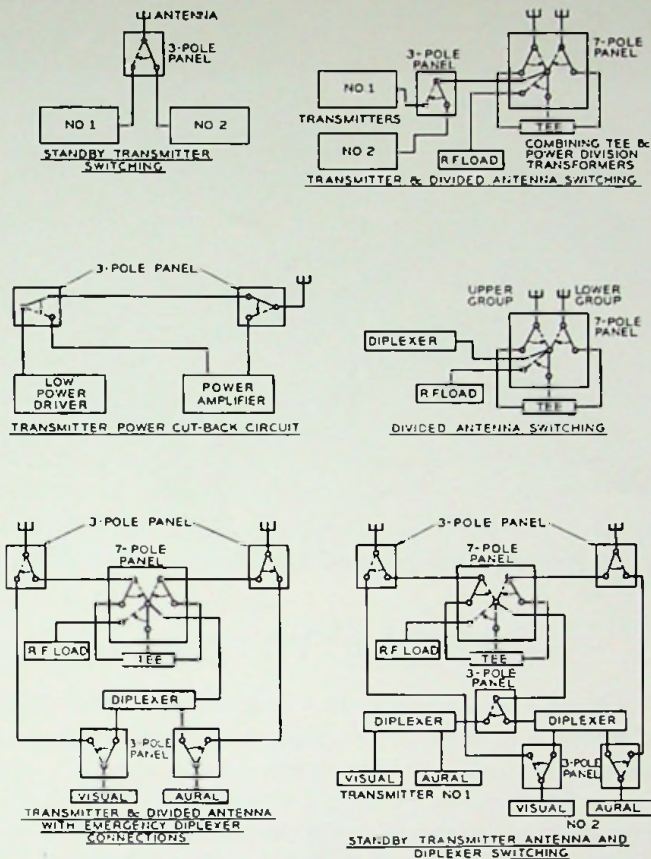

DESCRIPTION

The RCA Manual Transfer Panels utilize standard coaxial transmission line fittings which are mounted on a panel in such a way that switching functions are readily accomplished by the "patch cord" method. Fittings come in 3 1/8" or 6 1/8" diameter sizes and the switching plugs are constructed of double 3 1/8" or 6 1/8" elbows which form a "U" section. Therefore, the transmission line impedance is maintained through the panel. The panels are made up of a sturdy steel base plate reinforced with angle bends on all four sides. Holes are provided in side angles for mounting.

Two type panels are available, the 3-pole panel provided with one "U" type connector, and the 7-pole panel with three "U" type connectors. Adjustable clamps are provided for clamping the "U" type sleeve connectors to the fittings. There are different connections and impedances to suit all RCA VHF, UHF and Universal types of Transmission Line.

Manual transfer panels for coaxial lines with flange or clamp connections (as distinguished from sleeve) require at every connection an anchor connector of appropriate type. These are not provided with the connectors as some will be available in mating components. A survey must be made of additional connectors needed for each installation.

SPECIFICATIONS

Electrical:

Power rating..... Same as various Transmission Line to which they apply
 Ambient Temperature..... to 50° C
 Elevation..... 5000 ft. max. for full power rating
 VSWR..... 1.02 to 1 or better
 Impedance..... See Summary Table

Mechanical:

Dimensions..... See Outline Drawings
 Weight:
 3 Pole 3 1/8" Models..... 32 lbs. Approx.
 7 Pole 3 1/8" Models..... 67 lbs. Approx.
 3 Pole 6 1/8" Models..... 75 lbs. Approx.
 7 Pole 6 1/8" Models..... 220 lbs. Approx.

Accessory Equipment:

3 1/8" dia.—50 ohm adaptor for use with MI-27912-50 and 51..... MI-27912-52
 3 1/8" dia.—51.5 ohm adaptor for use with MI-27717 and MI-27718..... MI-27337
 6 1/8" dia.—51.5 ohm adaptor for use with MI-27719 and MI-27720..... MI-27709
 3 1/8" anchor connector for use with MI-27791-50 and 51..... MI-27791-12
 6 1/8" anchor connector for use with MI-27792-50 and 51..... MI-27792-12
 3 1/8" anchor connector for use with MI-27333 and MI-27334..... MI-19089-10
 6 1/8" anchor connector for use with MI-27710 and MI-27711..... MI-19287-10

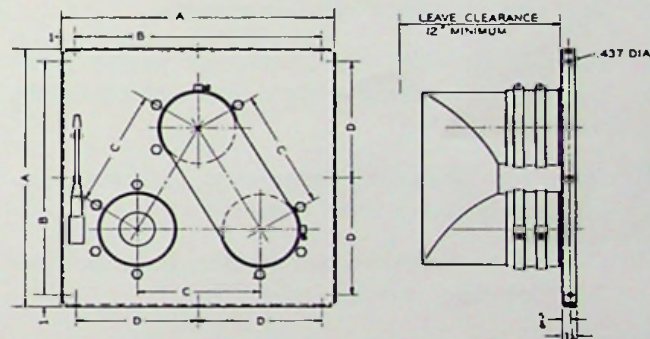

SIZE	A	B	C	D
3 1/8"	15 1/2	13 1/2	7	—
6 1/8"	25	23	13	11 1/2

Outline Dimensions, 3-Pole Panels

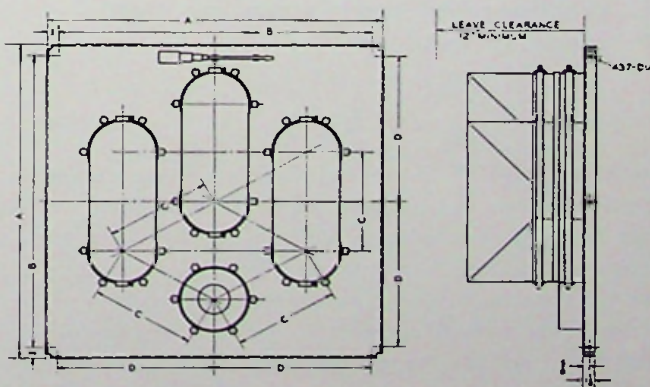

SIZE	A	B	C	D
3 1/8"	23	21	7	—
6 1/8"	38	36	13	18

Outline Dimensions, 7-Pole Panels

UHF/VHF DIRECTIONAL COUPLERS

MI-27379 - MI-27387 Inclusive

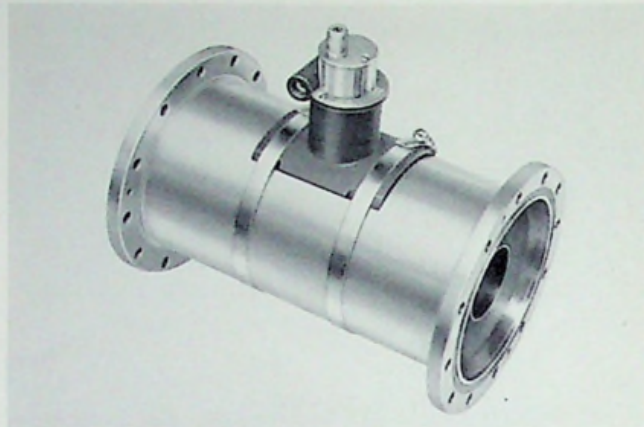
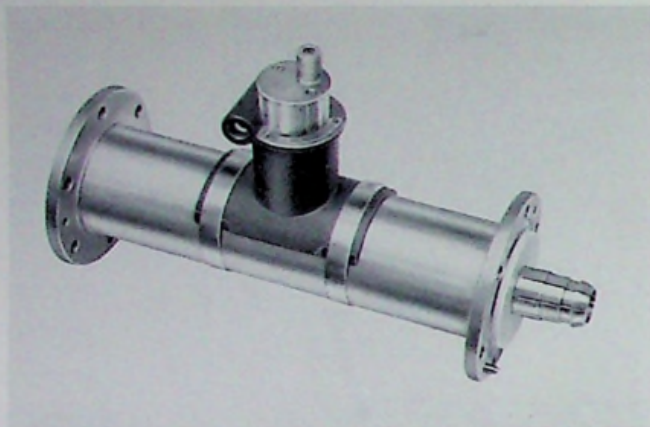

FEATURES

- Facilitates TV Transmitter tuning, operation and maintenance measurements
- Permits precise adjustment of probe position to accurately obtain correct sampling voltage
- Magnetic shielding provided to insure exclusion of undesired wave
- Choice of housing to mount in any type 3 1/8" or 6 1/8" transmission line
- Mounts like a transmission line component
- Hose clamps provide ease of mounting
- No maintenance required
- Weatherproof models are gas tight—mounted outdoors

USES

The RCA VHF/UHF Directional Couplers are designed to afford a means for coupling external monitoring equipment to the outputs of both VHF or UHF television transmitters to facilitate measurements required in conjunction with tuning, operating and maintenance of the transmitter. By installing several couplers in the output transmission lines, it is possible to couple measuring or monitoring equipment to the transmitter output at either side of the sideband filter (or Filterplexer), or at the Diplexer output.

DESCRIPTION

The Directional Coupler, which contains a coupling loop, is mounted in a section of transmission line. Angle and penetration scales on the coupler assembly enable precise adjustments to be made of the loop position. The coupler includes etched scales for accurately setting the depth of penetration of the r-f coupling loop, and the angular position of the coupling loop for calibration of the output voltage at the particular channel desired. The unit is capable of coupling adequate signal voltages with a VSWR of 1.03/1.0 or less.

The directional property of the coupler permits sampling on a transmitter output line without any of the attendant variations in frequency response observed with non-directional couplers. The monitor voltage obtained with a directional coupler in a transmitter output line is a sample voltage of the amplitude desired of either the incident or reflected wave, as chosen. In addition, the directional coupler presents a source impedance to the monitor cable essentially equal to the characteristic impedance of the monitor cable and independent of cable length.

Units such as the Sideband Response Analyzer (BW-5, or BWU-5), Demodulators (BW-4, BWU-4, WM-20) and Monitoring Diodes utilize directional couplers to provide signal sampling for these instruments. Reflectometers for VSWR and power output measurements require a coupler for incident and one for reflected wave readings.

While the Directional Couplers come mounted on appropriate transmission line sections, they may also be secured as separate accessories for those who may wish to adapt

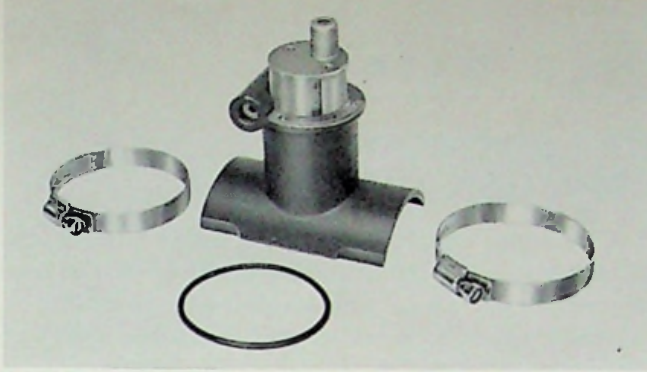

Directional Coupler (less coupler housing).

is slightly more than 4½" and the diameter approximately 1¾". The coupler has a 5/8-24 thread by ¾" deep to fit an "N" type plug connector with dust cap. They are provided with allen head locking screw (which may be on either side) and both horizontal and vertical scales to indicate angle and penetration settings. Both have a fixed composition resistor rated 50 ohms ±1% which may be renewed when necessary.

SPECIFICATIONS

Electrical

VSWR.....1.03/1.0 or less, for normal voltage coupling ranges

Mechanical

See diagrams and table.

Accessories

Directional Coupler (less 6½" Coupler Housing).....MI-27389
 Directional Coupler (less 3½" Coupler Housing).....MI-27390

them to their transmitter output lines. When proper holes are cut and mounting accessories affixed, MI-27389 may be mounted in any type 6½" transmission lines while the MI-27390 coupler is designed for all 3½" lines. The directional couplers are 4½" long and extend approximately ¾" above the coupler housing. The overall height

TABLE FOR DIRECTIONAL COUPLER SPECIFICATIONS

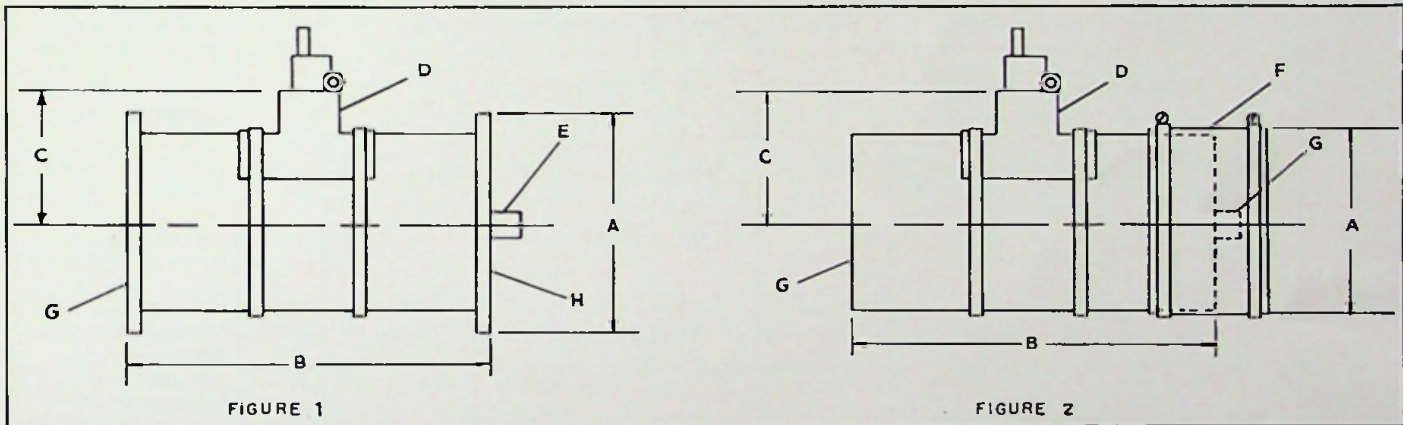

Stock Identification	MI-27379	MI-27380	MI-27381	MI-27382	MI-27383	MI-27384	MI-27385	MI-27386	MI-27387
Coupler Dwg	Fig. 1	Fig. 1	Fig. 2	Fig. 1	Fig. 1	Fig. 2	Fig. 1	Fig. 2	Fig. 1
Diameter "A"	3½"	3½"	3½"	6½"	6½"	6½"	3½"	3½"	6½"
Length "B"	12"	12"	12"	12"	12"	12"	12"	12"	12"
Depth "C"	3½/16"	3½/16"	3½/16"	5½/16"	5½/16"	5½/16"	3½/16"	3½/16"	5½/16"
Coupling "D"	MI-27390	MI-27390	MI-27390	MI-27389	MI-27389	MI-27389	MI-27390	MI-27390	MI-27389
Connector "E"	MI-19089-10	MI-19113C-11		MI-19387-10	MI-19314C-5		MI-27791-12		MI-27792-12
Coupling "F"			MI-19113C-8			MI-19314C-7		MI-27912-4	
Adapter "G"		MI-19313-11	MI-19313-11				None	None	
Flange "H"	MI-19089-11	MI-19113-20		MI-19387-11	MI-19314C-11		Universal		Universal
Impedance (Ohms)	50	51½	51½	75	51½	51½	50	50	75
TV Band	UHF	VHF	VHF	UHF	VHF	VHF	VHF or UHF	VHF	VHF or UHF
May be Pressurized	Yes	Yes	No	Yes	Yes	No	Yes	No	Yes
For Use with RCA Transmission Line	MI-19089	MI-19113 or MI-19313	MI-19113 or MI-19313	MI-19387	MI-19314C	MI-19314C	MI-27791	MI-27912	MI-27792

QUICK REFERENCE DATA

MECHANICAL AND ELECTRICAL SPECIFICATIONS OF RCA COAXIAL TRANSMISSION LINES

Each of the various types of RCA transmission line is designed for a particular application. The choice of line for an installation will depend principally upon the frequency in use and the power to be handled. Selection of the proper line will provide the most economical and efficient installation.

There is a comprehensive data table included below which should be helpful to the reader. Broadcast engineers and planners, by referring to this "Quick Reference Chart", can study the general overall characteristics and specifications

of RCA's entire complement of transmission lines. In this manner, the reader can select the particular transmission line meeting his application requirements and refer to the proper pages in this catalog for additional data and information.

For broadcast installations, the line selected should have a power rating which equals or exceeds the power output of the transmitter. If power increases are contemplated, it will be economical to install larger line than initially required, thus saving the cost of a new installation at a later time.

Catalog Page Nos.	Size	Stock Identification	Description	Impedance	O.D. of Inner Conductor (in.)	I.D. of Inner Conductor (in.)	Insulators Type—Spacing (in.)	Wt. lbs. per 100 ft.	Class of Service
7-9	3 1/8"	MI-27791	Quick disconnect flanged fittings, no solder—pressurized	50 ohm	1.315	1.231	Teflon (Wafer) —	280	VHF/UHF Television and FM installations
10-12	6 1/8"	MI-27792	Quick disconnect flanged fittings, no solder—pressurized	75 ohm	1.711	1.661	Teflon (Wafer) —	650	VHF/UHF Television and FM installations
13-14	9 1/8"	MI-27793	Quick disconnect flanged fittings, no solder—pressurized	75 ohm	2.580	2.516	Teflon (Wafer) —	1100	VHF/UHF Television and FM installations
26-27	1 5/8"	MI-19112	Flanged fittings, pressurized, no solder	51.5 ohm	.625	.569	Steatite (Wafer) 12	125	VHF Television and FM installations (up to 220 mc), AM lines
28-30	3 1/8"	MI-19113	Flanged fittings, no solder—pressurized	51.5 ohm	1.200	1.136	Steatite (Wafer) 12	250	VHF Television and FM installations (up to 108 mc), AM lines
32	3 1/8"	MI-27912	Unflanged fittings, no solder—unpressurized	50 ohm	1.315	1.231	Teflon (Wafer) 12	230	VHF Television indoor applications
33-36	6 1/8"	MI-19314-C	Flanged fittings, no solder—pressurized	51.5 ohm	2.500	2.435	Steatite (Pin Type) 12	730	VHF Television (up to 220 mc) and FM installations. For high power, high efficiency and exceptionally long runs
*	3/8"	MI-19306	Solder fittings, pressurized or unpressurized	72 ohm	.081	Solid	Steatite (Beaded) 1 3/4	16	Sampling and frequency checking in AM broadcast systems, mobile, aircraft
*	7/8"	MI-19307	Solder fittings, pressurized	72 ohm	.250	.187	Steatite (Wafer) 4	60	AM broadcast lines, phase sampling
*	7/8"	MI-19308	Flanged fittings, no solder—pressurized	72 ohm	.250	.187	Steatite (Wafer) 6	60	AM broadcast lines, phase sampling
*	7/8"	MI-19309	Flanged fittings, no solder—pressurized	51.5 ohm	.312	.250	Steatite (Wafer) 6	62	AM and FM broadcast line, phase sampling
*	7/8"	MI-19305	Solder fittings, pressurized	51.5 ohm	.312	.250	Steatite (Wafer) 6	60	AM and FM broadcast lines, phase sampling
*	1 1/8"	MI-19310	Flanged fittings, pressurized, no solder	72 ohm	.375	.312	Steatite (Wafer) 12	120	AM broadcast lines

* AM-FM Transmission Lines are listed here for convenient reference only. Refer to RCA's AM-FM Catalog for full description and other particulars.

INDEX

UNIVERSAL COAXIAL LINE

(For UHF/VHF Applications)

3/8" HARD COPPER 50-OHM UNIVERSAL TEFLON COAXIAL LINE AND FITTINGS (MI-27791 Series)

Page	Description	MI Number
7	Transmission Line, 20-ft. lengths.....	MI-27791-1
7	Transmission Line, 19 1/2-ft. lengths.....	MI-27791-2
7	Coupling, 90° Elbow (female outer, short leg).....	MI-27791-3
7	Coupling, 90° Elbow (male outer, short leg).....	MI-27791-4
7	Coupling, 90° Elbow (female outer, both legs).....	MI-27791-5
8	Coupling, 90° Elbow (male outer, both legs).....	MI-27791-6
8	Coupling, 45° Elbow (female outer, short legs).....	MI-27791-7
8	Coupling, 45° Elbow (male outer, short leg).....	MI-27791-8
8	Coupling, 45° Elbow (female outer, both legs).....	MI-27791-9
8	Coupling, 45° Elbow (male outer, both legs).....	MI-27791-10
8	Gas Stop.....	MI-27791-11
8	Connector, Inner.....	MI-27791-12
8	Adaptor, Female (soft solder assembly).....	MI-27791-13
8	Adaptor, Female (silver solder assembly).....	MI-27791-14
8	Adaptor, Male (soft solder assembly).....	MI-27791-15
8	Adaptor, Male (silver solder assembly).....	MI-27791-16
8	Gasket ("O" Ring).....	MI-27791-17
8	Marman Clamp.....	MI-27791-18
8	Adaptor (female outer to RETMA 3/8" 50-ohm coaxial line).....	MI-27791-31
8	Adaptor (male outer to RETMA 3/8" 50-ohm coaxial line).....	MI-27791-32
8	Adaptor (female outer to 3 1/8" 51.5-ohm coaxial line, channels 2 to 6).....	MI-27791-33
8	Adaptor (female outer to 3 1/8" 51.5-ohm coaxial line, channels 7 to 13).....	MI-27791-34
8	Adaptor (male outer to 3 1/8" 51.5-ohm coaxial line, channels 2 to 6).....	MI-27791-35
8	Adaptor (male outer to 3 1/8" 51.5-ohm coaxial line, channels 7 to 13).....	MI-27791-36

6/8" HARD COPPER 75-OHM UNIVERSAL TEFLON COAXIAL LINE AND FITTINGS (MI-27792 Series)

10	Transmission Line, 20-ft. lengths.....	MI-27792-1
11	Transmission Line, 19 1/2-ft. lengths.....	MI-27792-2
11	Coupling, 90° Elbow (female outer, short leg).....	MI-27792-3
11	Coupling, 90° Elbow (male outer, short leg).....	MI-27792-4
11	Coupling, 90° Elbow (female outer, both legs).....	MI-27792-5
11	Coupling, 90° Elbow (male outer, both legs).....	MI-27792-6
11	Coupling, 45° Elbow (female outer, short leg).....	MI-27792-7
11	Coupling, 45° Elbow (male outer, short leg).....	MI-27792-8
11	Coupling, 45° Elbow (female outer, both legs).....	MI-27792-9
11	Coupling, 45° Elbow (male outer, both legs).....	MI-27792-10
11	Gas Stop.....	MI-27792-11
11	Connector, Inner.....	MI-27792-12
11	Adaptor, Female (soft solder assembly).....	MI-27792-13
11	Adaptor, Female (silver solder assembly).....	MI-27792-14
11	Adaptor, Male (soft solder assembly).....	MI-27792-15
11	Adaptor, Male (silver solder assembly).....	MI-27792-16
11	Gasket ("O" Ring).....	MI-27792-17
11	Marman Clamp.....	MI-27792-18
11	Adaptor (female outer to RETMA 6/8" 75-ohm coaxial line).....	MI-27792-31
11	Adaptor (male outer to RETMA 6/8" 75-ohm coaxial line).....	MI-27792-32
11	Adaptor (female outer to Universal 3 1/8" 50-ohm coaxial with male outer).....	MI-27792-33
11	Adaptor (female outer to RETMA 3 1/8" 50-ohm coaxial line).....	MI-27792-34
11	Adaptor (female outer to 3 1/8" 51.5-ohm coaxial line, channels 2 and 3).....	MI-27792-35
11	Adaptor (female outer to 3 1/8" 51.5-ohm coaxial line, channels 4, 5 and 6).....	MI-27792-36
11	Adaptor (female outer to 3 1/8" 51.5-ohm coaxial line, channels 7 to 13).....	MI-27792-37
11	Adaptor, Female (Channel 2-4 Universal).....	MI-27792-38
11	Adaptor, Female (Channel 4-6, Universal).....	MI-27792-39
11	Adaptor, Female (Channel 7-13, Universal).....	MI-27792-40

**9 $\frac{3}{8}$ " HARD COPPER 75-OHM UNIVERSAL TEFLON COAXIAL LINE AND FITTINGS
(MI-27793 Series)**

<i>Page</i>	<i>Description</i>	<i>MI Number</i>
13	Transmission Line, 20-ft. lengths.....	MI-27793-1
13	Transmission Line, 19 $\frac{1}{2}$ -ft. lengths.....	MI-27793-2
13	Coupling, 90° Elbow (female outer, short leg).....	MI-27793-3
13	Coupling, 90° Elbow (male outer, short leg).....	MI-27793-4
13	Gas Stop	MI-27793-11
13	Connector, Inner	MI-27793-12
13	Adaptor, Female (soft solder assembly).....	MI-27793-13
13	Adaptor, Female (silver solder assembly).....	MI-27793-14
14	Adaptor, Male (soft solder assembly).....	MI-27793-15
14	Adaptor, Male (silver solder assembly).....	MI-27793-16
14	Gasket ("O" Ring).....	MI-27793-17
14	Marman Clamp	MI-27793-18
14	Adaptor (female outer to 6 $\frac{1}{8}$ " 75-ohm Universal Line with male outer).....	MI-27793-31
14	Adaptor (female outer to 6 $\frac{1}{8}$ " 75-ohm Universal Line with female outer).....	MI-27793-32
14	Adaptor (female outer to 6 $\frac{1}{8}$ " 75-ohm RETMA Line).....	MI-27793-33

VHF COAXIAL LINE

1 $\frac{5}{8}$ " HARD COPPER 51.5-OHM STEATITE COAXIAL LINE AND FITTINGS (MI-19112 Series)

26	Transmission Line, 20-ft. lengths, flanged.....	MI-19112-1
26	Transmission Line, 20-ft. lengths, 1 flange.....	MI-19112-1-F
26	Transmission Line, 20-ft. lengths, no flanges.....	MI-19112-1-NF
26	Coupling, 90° Elbow, flanged.....	MI-19112-2
26	Coupling, 90° Elbow, 1 flange.....	MI-19112-2-F
26	Coupling, 90° Elbow, no flange.....	MI-19112-2-NF
26	Coupling, 45° Elbow, flanged.....	MI-19112-3
26	Coupling, 45° Elbow, 1 flange.....	MI-19112-3-F
26	Coupling, 45° Elbow, no flanges.....	MI-19112-3-NF
26	Adaptor for Gassed Line.....	MI-19112-4
26	Gas Stop	MI-19112-5
26	Reducer Coupling (Gassed).....	MI-19112-6
27	Reducer Coupling (Ungassed).....	MI-19112-7
27	Straight Coupling	MI-19112-8
27	Special Inner Conductor.....	MI-19112-9
27	"O" Ring Gasket.....	MI-19112-10
27	Inner Connector	MI-19112-11
27	Line Gassing Accessories.....	MI-19112-12
27	Emergency Cover Plate.....	MI-19112-13
27	Adaptor	MI-19112-16
27	Coupling, 90° Mitre Elbow, flanged.....	MI-19112-18
27	Coupling, 90° Mitre Elbow, 1 flange.....	MI-19112-18-F
27	Coupling, 90° Mitre Elbow, no flanges.....	MI-19112-18-NF
27	Hardware Kit	MI-19112-19
27	Flange, Fixed	MI-19112-20
27	Flange, Swivel	MI-19112-21
27	Coupling, 45° Mitre Elbow, flanged.....	MI-19112-22
27	Coupling, 45° Mitre Elbow, 1 flange.....	MI-19112-22-F
27	Coupling, 45° Mitre Elbow, no flange.....	MI-19112-22-NF
27	Reducer, 1 $\frac{5}{8}$ " Ungassed.....	MI-19112-53
27	Reducer, 1 $\frac{5}{8}$ " Gassed.....	MI-19112-59
27	Adaptor for Ungassed Line.....	MI-19112-60

**3 $\frac{1}{8}$ " HARD COPPER 51.5-OHM STEATITE COAXIAL TRANSMISSION LINE
AND FITTINGS (MI-19113 Series)**

28	Transmission Line, 20-ft. lengths, flanged.....	MI-19113-B-1
28	Transmission Line, 20-ft. lengths, 1 flange.....	MI-19113-B-1-F
28	Transmission Line, 20-ft. lengths, no flanges.....	MI-19113-B-1-NF
28	Transmission Line, 20-ft. lengths, 1 fixed and 1 swivel flange.....	MI-19113-B-1-SF

**3/8" HARD COPPER 51.5-OHM STEATITE COAXIAL TRANSMISSION LINE
AND FITTINGS (MI-19113 Series)—(Continued)**

<i>Page</i>	<i>Description</i>	<i>MI Number</i>
28	Coupling, 90° Elbow, 1 fixed and 1 swivel flange.....	MI-19113-B-2
29	Coupling, 90° Elbow, 1 swivel flange.....	MI-19113-B-2-F
29	Coupling, 90° Elbow, no flanges.....	MI-19113-B-2-NF
29	Coupling, 45° Elbow, 1 fixed and 1 swivel flange.....	MI-19113-B-3
29	Coupling, 45° Elbow, 1 swivel flange.....	MI-19113-B-3-F
29	Coupling, 45° Elbow, no flanges.....	MI-19113-B-3-NF
29	Adaptor for Gassed Line.....	MI-19113-C-4
29	Gas Stop.....	MI-19113-C-5
29	Reducer Coupling 3/8" to 1/4" Gassed Line.....	MI-19113-C-6
29	Reducer Coupling 3/8" to 1/4" Ungassed Line.....	MI-19113-C-7
29	Straight Coupling.....	MI-19113-C-8
29	Special Inner Conductor.....	MI-19113-C-9
29	"O" Ring Gasket.....	MI-19113-C-10
29	Inner Connector.....	MI-19113-C-11
29	Cover Plate.....	MI-19113-C-13
29	End Seal.....	MI-19113-C-17
30	Coupling, 90° Mitre Elbow, Flanged.....	MI-19113-C-18
30	Coupling, 90° Mitre Elbow, 1 flange.....	MI-19113-C-18-F
30	Coupling, 90° Mitre Elbow, no flanges.....	MI-19113-C-18-NF
30	Hardware Kit.....	MI-19113-C-19
30	Fixed Flange.....	MI-19113-C-20
30	Swivel Flange.....	MI-19113-C-21
30	Coupling, 45° Mitre Elbow, flange.....	MI-19113-C-22
30	Coupling, 45° Mitre Elbow, 1 flange.....	MI-19113-C-22-F
30	Coupling, 45° Mitre Elbow, no flanges.....	MI-19113-C-22-NF
30	Cut-Off Gauge.....	MI-19113-C-51
30	Transformer, 51.5-ohm to 50-ohm, channels 7 to 13.....	MI-19113-C-53
30	Cut-Off Gauge.....	MI-19113-C-54
30	Solder-Type Adaptor.....	MI-19113-C-55
30	Reducer.....	MI-19113-C-58
30	Flanged Adaptor for Ungassed Line.....	MI-19113-C-60

**SPECIAL 3/8" HARD COPPER 50-OHM TEFLON INDOOR TYPE TRANSMISSION LINE
AND FITTINGS (MI-27912 Series)**

32	Transmission Line, 20-ft. lengths, unflanged.....	MI-27912-1
32	Coupling, 90° Mitre Elbow, no flanges.....	MI-27912-2
32	Coupling, 45° Mitre Elbow, no flanges.....	MI-27912-3
32	Coupling.....	MI-27912-4
32	Inner Connector.....	MI-27912-5
32	Adjustable Clamp.....	MI-27912-6
32	Adaptor, Female.....	MI-27912-7
32	Adaptor, Male.....	MI-27912-8
32	Reducer.....	MI-27912-9

6/8" HARD COPPER 51.5-OHM STEATITE COAXIAL LINE AND FITTINGS (MI-19314-C Series)

33	Transmission Line, 10-ft. lengths, no flanges.....	MI-19314-C-1A
33	Transmission Line, 19-ft. lengths, flanged.....	MI-19314-C-1B
33	Transmission Line, 20-ft. lengths, flanged.....	MI-19314-C-1C
33	Transmission Line, 20-ft. lengths, 1 fixed and 1 swivel flange.....	MI-19314-C-1D
33	Transmission Line, 19-ft. lengths, 1 fixed and 1 swivel flange.....	MI-19314-C-1E
33	Transmission Line, 20-Ft. length, 1 flange.....	MI-19314-C-1F
33	Reducer Coupling, 6/8" to 3/4" Gassed Line.....	MI-19314-C-4
33	Inner Connector.....	MI-19314-C-5
33	Straight Coupling.....	MI-19314-C-7
33	Cover Plate.....	MI-19314-C-8
33	"O" Ring Gasket.....	MI-19314-C-9
33	Hardware Kit.....	MI-19314-C-10
33	Fixed Flange.....	MI-19314-C-11
35	Swivel Flange.....	MI-19314-C-12
35	Reducer Coupling 6/8" to 3/4" Ungassed Line.....	MI-19314-C-13

**6 1/8" HARD COPPER 51.5-OHM STEATITE COAXIAL LINE AND FITTINGS
(MI-19314-C Series)—(Continued)**

Page	Description	MI Number
35	Solder Type Adaptor.....	MI-19314-C-14
35	Cut-Off Gauge	MI-19314-C-16
35	Coupling, 90° Mitre Elbow, flanged.....	MI-19314-C-18
35	Coupling, 90° Mitre Elbow, 1 flange.....	MI-19314-C-18-F
35	Coupling, 90° Mitre Elbow, no flanges.....	MI-19314-C-18-NF
35	Coupling, 45° Mitre Elbow, flanged.....	MI-19314-C-22
35	Coupling, 45° Mitre Elbow, 1 flange.....	MI-19314-C-22-F
35	Coupling, 45° Mitre Elbow, no flanges.....	MI-19314-C-22-NF
35	Special Inner Conductor.....	MI-19314-C-23
35	Hose Clamp	MI-19314-C-39
35	Gas Stop	MI-19314-C-52
35	Tool Kit	MI-19314-C-53

TV TRANSMISSION LINE HANGERS

Fixed Hangers

43	Fixed Hanger for 1 3/8" Single Line (Clamp on Round Member).....	MI-19312-41
43	Fixed Hanger for 1 5/8" Single Line (Clamp on Round Member).....	MI-19312-42
43	Fixed Hanger for 3 1/8" Single Line (Clamp on Round Member).....	MI-19313-41
43	Fixed Hanger for 3 1/8" Single Line (Clamp on Round Member).....	MI-19313-42
43	Fixed Hanger for 6 1/8" Single Line (Mount Through Hole).....	MI-19314-44
43	Fixed Hanger for 9 3/8" Single Line (Mount Through Hole).....	MI-27900-44
43	Fixed Hanger for 1 3/8" Single Line (Mount Through Hole).....	MI-19312-44
43	Fixed Hanger for 1 7/8" Single Line (Mount Through Hole).....	MI-19312-47
43	Fixed Hanger for 3 1/8" Single Line (Mount Through Hole).....	MI-19313-44
43	Fixed Hanger for 3 1/8" Single Line (Mount Through Hole).....	MI-19313-47
43	Fixed Hanger for 1 3/8" Dual Line (Mount Through Hole).....	MI-19112-15
43	Fixed Hanger for 1 3/8" Dual Line (Mount Through Hole).....	MI-19112-49
43	Fixed Hanger for 3 1/8" Dual Line (Mount Through Hole).....	MI-19113-15
43	Fixed Hanger for 3 1/8" Dual Line (Mount Through Hole).....	MI-19113-19
43	Fixed Hanger for 1 3/8" Single Line (Clamp on Flat Member).....	MI-19312-10
43	Fixed Hanger for 3 1/8" Single Line (Clamp on Flat Member).....	MI-19313-10
43	Fixed Hanger for 1 5/8" Single Line (Clamp on Angular Member).....	MI-19312-43
43	Fixed Hanger for 3 1/8" Single Line (Clamp on Angular Member).....	MI-19313-43

Expansion Hangers

45	Expansion Hanger for 1 5/8" Single Line (Clamp on Round Member).....	MI-19312-23
45	Expansion Hanger for 1 5/8" Single Line (Clamp on Round Member).....	MI-19312-24
45	Expansion Hanger for 1 5/8" Single Line (Clamp on Round Members).....	MI-19312-26
45	Expansion Hanger for 1 3/8" Single Line (Clamp on Round Members).....	MI-19312-27
45	Expansion Hanger for 1 3/8" Single Line (Clamp on Round Member).....	MI-19312-25
45	Expansion Hanger for 1 5/8" Single Line (Clamp on Round Member).....	MI-19312-28
45	Expansion Hanger for 3 1/8" Single Line (Clamp on Round Member).....	MI-19313-23
45	Expansion Hanger for 3 1/8" Single Line (Clamp on Round Member).....	MI-19313-24
45	Expansion Hanger for 3 1/8" Single Line (Clamp on Round Members).....	MI-19313-26
45	Expansion Hanger for 3 1/8" Single Line (Clamp on Round Members).....	MI-19313-27
45	Expansion Hanger for 3 1/8" Single Line (Clamp on Round Members).....	MI-19313-25
45	Expansion Hanger for 3 1/8" Single Line (Clamp on Round Members).....	MI-19313-28
45	Expansion Hanger for 6 1/8" Single Line (Mount Through Hole—grounded).....	MI-19314-32
45	Expansion Hanger for 9 3/8" Single Line (Mount Through Hole—grounded).....	MI-27900-32
45	Expansion Hanger for 6 1/8" Single Line (Mount Through Hole—insulated).....	MI-19314-34
45	Expansion Hanger for 9 3/8" Single Line (Mount Through Hole—insulated).....	MI-27900-34
45	Expansion Hanger for 1 5/8" Single Line (Mount Through Hole).....	MI-19312-32
45	Expansion Hanger for 1 3/8" Single Line (Mount Through Hole).....	MI-19312-33
45	Expansion Hanger for 1 3/8" Single Line (Mount Through Hole).....	MI-19312-34
45	Expansion Hanger for 3 1/8" Single Line (Mount Through Hole).....	MI-19313-32
45	Expansion Hanger for 3 1/8" Single Line (Mount Through Hole).....	MI-19313-33
45	Expansion Hanger for 3 1/8" Single Line (Mount Through Hole).....	MI-19313-34
45	Expansion Hanger for 1 3/8" Dual Line (Mount Through Hole).....	MI-19112-14
45	Expansion Hanger for 1 3/8" Dual Line (Mount Through Hole).....	MI-19112-48
45	Expansion Hanger for 3 1/8" Dual Line (Mount Through Hole).....	MI-19113-14
45	Expansion Hanger for 3 1/8" Dual Line (Mount Through Hole).....	MI-19113-48
45	Expansion Hanger for 1 3/8" Single Line (Clamp on Flat Members).....	MI-19312-20
45	Expansion Hanger for 1 5/8" Single Line (Clamp on Flat Members).....	MI-19312-21
45	Expansion Hanger for 1 5/8" Single Line (Clamp on Flat Members).....	MI-19312-22
45	Expansion Hanger for 3 1/8" Single Line (Clamp on Flat Members).....	MI-19313-20
45	Expansion Hanger for 3 1/8" Single Line (Clamp on Flat Members).....	MI-19313-21

TV TRANSMISSION LINE HANGERS—(Continued)

Page	Description	MI Number
45	Expansion Hanger for 3 $\frac{1}{8}$ " Single Line (Clamp on Flat Members).....	MI-19313-22
45	Expansion Hanger for 1 $\frac{7}{8}$ " Single Line (Clamp on Angular Members).....	MI-19312-29
45	Expansion Hanger for 1 $\frac{5}{8}$ " Single Line (Clamp on Angular Members).....	MI-19312-30
45	Expansion Hanger for 1 $\frac{7}{8}$ " Single Line (Clamp on Angular Members).....	MI-19312-31
45	Expansion Hanger for 3 $\frac{1}{8}$ " Single Line (Clamp on Angular Members).....	MI-19313-29
45	Expansion Hanger for 3 $\frac{1}{8}$ " Single Line (Clamp on Angular Members).....	MI-19313-30
45	Expansion Hanger for 3 $\frac{1}{8}$ " Single Line (Clamp on Angular Members).....	MI-19313-31

Miscellaneous Transmission Line Accessories

47	Horizontal Anchor for Supporting 1 $\frac{5}{8}$ " Single Line.....	MI-19312-17
47	Horizontal Anchor for Supporting 3 $\frac{1}{8}$ " Single Line.....	MI-19313-17
47	Horizontal Anchor for Supporting 6 $\frac{1}{8}$ " Single Line.....	MI-19314-48
47	Horizontal Anchor for Supporting 9 $\frac{3}{8}$ " Single Line.....	MI-27900-48
47	Horizontal Anchor for Supporting 1 $\frac{7}{8}$ " Dual Lines.....	MI-19312-18
47	Horizontal Anchor for Supporting 3 $\frac{1}{8}$ " Dual Lines.....	MI-19313-18
47	Horizontal Anchor for Supporting 6 $\frac{1}{8}$ " Dual Lines.....	MI-19314-49
47	Horizontal Anchor for Supporting 9 $\frac{3}{8}$ " Dual Lines.....	MI-27900-49
47	Horizontal Roller Assembly for 1 $\frac{5}{8}$ " Line.....	MI-19312-35
47	Horizontal Roller Assembly for 3 $\frac{1}{8}$ " Line.....	MI-19313-35
47	Horizontal Roller Assembly for 6 $\frac{1}{8}$ " Line.....	MI-19314-35
47	Horizontal Roller Assembly for 9 $\frac{3}{8}$ " Line.....	MI-27900-35
47	Lateral Brace for Supporting 1 $\frac{5}{8}$ " Single Line.....	MI-19312-36
47	Lateral Brace for Supporting 3 $\frac{1}{8}$ " Single Line.....	MI-19313-36
47	Lateral Brace for Supporting 6 $\frac{1}{8}$ " Single Line.....	MI-19314-36
47	Lateral Brace for Supporting 9 $\frac{3}{8}$ " Single Line.....	MI-27900-36
47	Line Spreader for 1 $\frac{7}{8}$ " Lines.....	MI-19312-19
47	Line Spreader for 3 $\frac{1}{8}$ " Lines.....	MI-19313-19
47	Swivel Hanger for Supporting 1 $\frac{7}{8}$ " Single Line.....	MI-19312-37
47	Swivel Hanger for Supporting 1 $\frac{5}{8}$ " Dual Lines.....	MI-19312-38
47	Swivel Hanger for Supporting 3 $\frac{1}{8}$ " Single Line.....	MI-19313-37
47	Swivel Hanger for Supporting 3 $\frac{1}{8}$ " Dual Lines.....	MI-19313-38
47	Three-Point Expansion Hanger for 6 $\frac{1}{8}$ " Single Line.....	MI-19314-50
47	Three-Point Expansion Hanger for 9 $\frac{3}{8}$ " Single Line.....	MI-27900-50
47	Three-Point Expansion Hanger for 6 $\frac{1}{8}$ " Dual Lines.....	MI-19314-51
47	Three-Point Expansion Hanger for 9 $\frac{3}{8}$ " Dual Lines.....	MI-27900-51
47	Extension Kit for Mounting Grounded Dual Hangers.....	MI-19113-16

Indoor Transmission Line Hangers

51	Hanger Kit for 3 $\frac{1}{8}$ " Line (attaches to line for Ceiling Support at six [6] points).....	MI-27700
51	Hanger Kit for 6 $\frac{1}{8}$ " Line (attaches to line for Ceiling Support at six [6] points).....	MI-27701
51	Hanger Wall Bracket Kit.....	MI-27702
51	Hanger Wall Bracket Extension Kit.....	MI-27703
51	Mounting Kit (for attachment to soft surfaces).....	MI-27704
51	Hanger Kit (for attachment to "I" Beam).....	MI-27705
51	Hanger Kit (for attachment to Concrete Surfaces).....	MI-27706

Dehydrator Equipment and Accessories

54	1 Cu. Ft. Double Desiccant Dehydrator.....	MI-27318-1
54	1.5 Cu. Ft. Double Desiccant Dehydrator.....	MI-27318-2
54	2 Cu. Ft. Double Desiccant Dehydrator.....	MI-27318-3
54	1 Cu. Ft. Single Desiccant Dehydrator.....	MI-27318-4
56	Dual Line Gassing Accessories Kit.....	MI-19112-12
56	50-ft. Coil of $\frac{1}{4}$ " O.D. Soft Drawn Copper Tubing.....	MI-19315-1
56	90° Elbow $\frac{1}{8}$ " x $\frac{1}{8}$ " IPS.....	MI-19315-2
56	Flare Fitting, Female.....	MI-19315-3
56	Flare Fitting, Male.....	MI-19315-4
56	Flare Fitting Union Nut, $\frac{1}{8}$ "-20 Thread.....	MI-19314-5
56	Flare Fitting, Female.....	MI-19315-6
56	Pipe Plug, $\frac{1}{8}$ " IPS.....	MI-19315-7
56	Pipe Plug, $\frac{1}{4}$ " IPS.....	MI-19315-8
56	Nipple, Brass $\frac{1}{8}$ " IPS, 1 $\frac{1}{2}$ " long.....	MI-19315-9
56	Precision Needle Valve, $\frac{1}{8}$ " IPS Thread.....	MI-19315-10
56	Gas Admission Valve.....	MI-19315-11
56	Bleeder Valve.....	MI-19315-12
56	Brass Tee Fitting, $\frac{1}{8}$ " x $\frac{1}{8}$ " x $\frac{1}{8}$ " IPS.....	MI-19315-13
56	Pressure Gauge.....	MI-19315-14

TV TRANSMISSION LINE HANGERS—(Continued)

<i>Page</i>	<i>Description</i>	<i>MI Number</i>
56	Distribution Manifold	MI-19315-15
56	Service Tee, 1/4"	MI-19315-16
56	Fitting Nipple, 1/4" IPS Brass.....	MI-19315-17
56	Brass Reducing Bushing.....	MI-19315-18
56	Kit of Gassing Accessories.....	MI-19315-20
56	Two-Stage Pressure Reducing Regulator for Nitrogen-Gassed Lines.....	MI-19315-21
56	Single Stage Pressure Reducing Regulator for Nitrogen-Gassed Lines.....	MI-19315-22
56	Reducing Relief Valve.....	MI-19315-23
56	Kit of Accessories for Gassing Single Line with Nitrogen.....	MI-19315-24
56	Flared Double-Ended Union Fitting.....	MI-19315-25
56	Plain Pipe Coupling.....	MI-19315-26
56	Dehydrator Hose with snap-on connectors.....	MI-19315-27
56	Flaring and Cutting Tool Kit.....	MI-19315-28

POWER SWITCHING

57	VHF Automatic Coaxial Switch, 51.5-ohm Line.....	MI-27330
57	VHF Automatic Coaxial Switch, 50-ohm Line.....	MI-27335
58	3/8" 3-Pole, Sleeve Type Manual Transfer Panel, 51.5-ohms.....	MI-27717
58	3/8" 7-Pole, Sleeve Type Manual Transfer Panel, 51.5-ohms.....	MI-27718
58	6/8" 3-Pole, Sleeve Type Manual Transfer Panel, 51.5-ohms.....	MI-27719
58	6/8" 7-Pole, Sleeve Type Manual Transfer Panel, 51.5-ohms.....	MI-27720
58	3/8" 3-Pole, Flange Type Manual Transfer Panel, 50-ohms.....	MI-27333
58	3/8" 7-Pole, Flange Type Manual Transfer Panel, 50-ohms.....	MI-27334
58	6/8" 3-Pole, Flange Type Manual Transfer Panel, 75-ohms.....	MI-27710
58	6/8" 7-Pole, Flange Type Manual Transfer Panel, 75-ohms.....	MI-27711
58	3/8" 3-Pole, Clamp Type Manual Transfer Panel, 50-ohms.....	MI-27791-50
58	3/8" 7-Pole, Clamp Type Manual Transfer Panel, 50-ohms.....	MI-27791-51
58	6/8" 3-Pole, Clamp Type Manual Transfer Panel, 75-ohms.....	MI-27792-50
58	6/8" 7-Pole, Clamp Type Manual Transfer Panel, 75-ohms.....	MI-27792-51
58	3/8" 3-Pole, Indoor Type Manual Transfer Panel, 50-ohms.....	MI-27912-50
58	3/8" 7-Pole, Indoor Type Manual Transfer Panel, 50-ohms.....	MI-27912-51
59	50-ohm Adaptor for use with MI-27912-50/51.....	MI-27912-52
59	51.5-ohm Adaptor for use with MI-27717 or MI-27718.....	MI-27337
59	51.5-ohm Adaptor for use with MI-27719 or MI-27720.....	MI-27709
59	3/8" Anchor Connector for use with MI-27333 and MI-27334.....	MI-19089-10
59	6/8" Anchor Connector for use with MI-27710 and MI-27711.....	MI-19287-10

DIRECTIONAL COUPLERS

61	Directional Coupler for use with MI-19089 Transmission Line.....	MI-27379
61	Directional Coupler for use with MI-19113 or MI-19313 Pressurized Transmission Line.....	MI-27380
61	Directional Coupler for use with MI-19113 or MI-19313 Non-pressurized Transmission Line.....	MI-27381
61	Directional Coupler for use with MI-19387 Transmission Line.....	MI-27382
61	Directional Coupler for use with MI-19314-C Pressurized Transmission Line.....	MI-27383
61	Directional Coupler for use with MI-19314-C Non-pressurized Transmission Line.....	MI-27384
61	Directional Coupler for use with MI-27791 Transmission Line.....	MI-27385
61	Directional Coupler for use with MI-27912 Transmission Line.....	MI-27386
61	Directional Coupler for use with MI-27792 Transmission Line.....	MI-27387
61	Directional Coupler (less 6/8" Coupler Housing).....	MI-27389
61	Directional Coupler (less 3/8" Coupler Housing).....	MI-27390
62	Quick Reference Chart	

**RCA REGIONAL
OFFICES**

Atlanta 3, Ga.

1121 Rhodes-Haverty Bldg., Jackson 4-7703

Boston 16, Mass.

200 Berkeley Street, Hubbard 2-1700

Camden 2, N. J.

Front & Cooper Streets, Woodlawn 3-8000

Chicago 54, Ill.

1186 Merchandise Mart Plaza, Delaware 7-0700

Cleveland 15, Ohio

1600 Keith Bldg., Cherry 1-3450

Dallas 35, Texas

7901 Freeway #183, Fleetwood 2-3911

Hollywood 28, Calif.

1560 N. Vine Street, Hollywood 9-2154

Kansas City 6, Mo.

1006 Grand Avenue, Harrison 1-6480

New York 20, N. Y.

36 W. 49th Street, Judson 6-3800

San Francisco 2, Calif.

420 Taylor Street, Ordway 3-8027

Seattle 4, Wash.

2250 First Avenue, South, Main 8350

Washington 6, D. C.

1625 K Street, N. W., District 7-1260



RADIO CORPORATION OF AMERICA
BROADCAST & TELEVISION EQUIPMENT **CAMDEN, NEW JERSEY**

PRICE LIST

FOR

Broadcast Transmission Line



PRICES EFFECTIVE NOVEMBER 1, 1957

Broadcast and Television Equipment
Radio Corporation of America
Commercial Electronic Products
Camden, N. J.

ORDERING INFORMATION

RCA broadcast equipment is sold directly to broadcast stations through the Commercial Electronic Products Broadcast Field Sales Representatives operating out of the convenient field offices listed below. These Broadcast specialists are available to assist you in discussing the application of broadcast equipment and related problems.

In ordering equipment, please indicate the Master Item (MI) number for each equipment. This will help us to speed the shipment to you. You will find the Master Item (MI) numbers are used to identify the equipment on the invoices and packing slips.

The Purchaser shall be responsible for all transportation charges, and shipments will normally be forwarded with shipping charges "collect." However, shipping charges can be prepaid and added to the billing invoice if your purchase order authorizes this method. We suggest that you consider the latter procedure since it eliminates the necessity of having petty cash on hand at the time of delivery. Your purchase order should specify the method of transportation desired, otherwise RCA will use its best judgment. The cheapest method of transportation is not always used as this may not always result in the most rapid delivery. Certain items, such as vacuum tubes, are usually shipped by Express because of the design of carrying container, insurance, etc.

Field Offices

Front & Cooper Streets
CAMDEN 2, NEW JERSEY
Woodlawn 3-8000

Rhodes-Haverty Bldg., Rm. 1121
134 Peachtree Street, N.W.
ATLANTA 3, GEORGIA
Jackson 4-7703

200 Berkeley Street
BOSTON 16, MASSACHUSETTS
Hubbard 2-1700

1186 Merchandise Mart Plaza
CHICAGO 54, ILLINOIS
Delaware 7-0700

1600 Keith Building
CLEVELAND 15, OHIO
Cherry 1-3450

P.O. Box 35025, Airlawn Station
(7901 Freeway #183)
DALLAS 35, TEXAS
Fleetwood 2-3911

1560 North Vine Street
HOLLYWOOD 28, CALIFORNIA
Hollywood 9-2154

1006 Grand Avenue
KANSAS CITY 6, MISSOURI
Harrison 1-6480

36 West 49th Street
NEW YORK 20, NEW YORK
Judson 6-3800

420 Taylor Street—3rd Floor
SAN FRANCISCO 2, CALIFORNIA
Ordway 3-8027

2250 First Avenue, South
SEATTLE 4, WASHINGTON
Main 8350

1625 K Street, N.W.
WASHINGTON 6, D. C.
District 7-1260

CONTENTS

Broadcast Transmission Line Price List

	<i>Page</i>
Universal Coaxial Transmission Line	4, 5
VHF Coaxial Transmission Line	5, 6, 7
Transmission Line Accessories	7, 8, 9
Power Switching	10
Directional Couplers	10

BROADCAST TRANSMISSION LINE

UNIVERSAL COAXIAL TRANSMISSION LINE

3/8" HARD COPPER 50-OHM UNIVERSAL TEFLON COAXIAL LINE AND FITTINGS (MI-27791 Series)

Page	MI Number	Description	Price
7	MI-27791-1	Transmission Line, 20-ft. lengths.....	\$ 130.00
7	MI-27791-2	Transmission Line, 19 1/2-ft. lengths.....	130.00
7	MI-27791-3	Coupling, 90° Elbow (female outer, short leg).....	76.00
7	MI-27791-4	Coupling, 90° Elbow (male outer, short leg).....	76.00
7	MI-27791-5	Coupling, 90° Elbow (female outer, both legs).....	78.00
8	MI-27791-6	Coupling, 90° Elbow (male outer, both legs).....	75.00
8	MI-27791-7	Coupling, 45° Elbow (female outer, short legs).....	76.00
8	MI-27791-8	Coupling, 45° Elbow (male outer, short leg).....	76.00
8	MI-27791-9	Coupling, 45° Elbow (female outer, both legs).....	78.00
8	MI-27791-10	Coupling, 45° Elbow (male outer, both legs).....	75.00
8	MI-27791-11	Gas Stop	45.00
8	MI-27791-12	Connector, Inner	16.00
8	MI-27791-13	Adaptor, Female (soft solder assembly).....	21.50
8	MI-27791-14	Adaptor, Female (silver solder assembly).....	5.00
8	MI-27791-15	Adaptor, Male (soft solder assembly).....	20.00
8	MI-27791-16	Adaptor, Male (silver solder assembly).....	4.25
8	MI-27791-17	Gasket ("O" Ring).....	.45
8	MI-27791-18	Marman Clamp	4.75
8	MI-27791-31	Adaptor (female outer to RETMA 3/8" 50-ohm coaxial line).....	42.00
8	MI-27791-32	Adaptor (male outer to RETMA 3/8" 50-ohm coaxial line).....	41.00
8	MI-27791-33	Adaptor (female outer to 3/8" 51.5-ohm coaxial line, channels 2 to 6).....	83.25
8	MI-27791-34	Adaptor (female outer to 3/8" 51.5-ohm coaxial line, channels 7 to 13).....	60.00
8	MI-27791-35	Adaptor (male outer to 3/8" 51.5-ohm coaxial line, channels 2 to 6).....	82.00
8	MI-27791-36	Adaptor (male outer to 3/8" 51.5-ohm coaxial line, channels 7 to 13).....	59.00

6/8" HARD COPPER 75-OHM UNIVERSAL TEFLON COAXIAL LINE AND FITTINGS (MI-27792 Series)

10	MI-27792-1	Transmission Line, 20-ft. lengths.....	\$ 325.00
11	MI-27792-2	Transmission Line, 19 1/2-ft. lengths.....	325.00
11	MI-27792-3	Coupling, 90° Elbow (female outer, short leg).....	190.00
11	MI-27792-4	Coupling, 90° Elbow (male outer, short leg).....	190.00
11	MI-27792-5	Coupling, 90° Elbow (female outer, both legs).....	190.00
11	MI-27792-6	Coupling, 90° Elbow (male outer, both legs).....	190.00
11	MI-27792-7	Coupling, 45° Elbow (female outer, short leg).....	190.00
11	MI-27792-8	Coupling, 45° Elbow (male outer, short leg).....	190.00
11	MI-27792-9	Coupling, 45° Elbow (female outer, both legs).....	190.00
11	MI-27792-10	Coupling, 45° Elbow (male outer, both legs).....	190.00
11	MI-27792-11	Gas Stop	168.00
11	MI-27792-12	Connector, Inner	36.00
11	MI-27792-13	Adaptor, Female (soft solder assembly).....	38.50
11	MI-27792-14	Adaptor, Female (silver solder assembly).....	12.00
11	MI-27792-15	Adaptor, Male (soft solder assembly).....	38.50
11	MI-27792-16	Adaptor, Male (Silver solder assembly).....	12.00
11	MI-27792-17	Gasket ("O" Ring).....	.80
11	MI-27792-18	Marman Clamp	7.50
11	MI-27792-31	Adaptor (female outer to RETMA 6/8" 75-ohm coaxial line).....	110.00
11	MI-27792-32	Adaptor (male outer to RETMA 6/8" 75-ohm coaxial line).....	110.00

Page	MI Number	Description	Price
11	MI-27792-33	Adaptor (female outer to Universal 3 1/8" 50-ohm coaxial with male outer).....	168.00
11	MI-27792-34	Adaptor (female outer to RETMA 3 1/8" 50-ohm coaxial line).....	168.00
11	MI-27792-35	Adaptor (female outer to 3 1/8" 51.5-ohm coaxial line, channels 2 and 3).....	195.00
11	MI-27792-36	Adaptor (female outer to 3 1/8" 51.5-ohm coaxial line, channels 4, 5 & 6).....	195.00
11	MI-27792-37	Adaptor (female outer to 3 1/8" 51.5-ohm coaxial line, channels 7 to 13).....	168.00
11	MI-27792-38	Adaptor, Female (Channel 2-3 Universal).....	195.00
11	MI-27792-39	Adaptor, Female (Channel 4-6, Universal).....	195.00
11	MI-27792-40	Adaptor, Female (Channel 7-13, Universal).....	168.00

**9/16" HARD COPPER 75-OHM UNIVERSAL TEFLON COAXIAL LINE AND FITTINGS
(MI-27793 Series)**

13	MI-27793-1	Transmission Line, 20-ft. lengths.....	(On application)
13	MI-27793-2	Transfission Line, 19 1/2-ft. lengths.....	(On application)
13	MI-27793-3	Coupling, 90° Elbow (female outer, short leg).....	(On application)
13	MI-27793-4	Coupling, 90° Elbow (male outer, short leg).....	(On application)
13	MI-27793-11	Gas Stop	(On application)
13	MI-27793-12	Connector, Inner	(On application)
13	MI-27793-13	Adaptor, Female (soft solder assembly).....	(On application)
13	MI-27793-14	Adaptor, Female (silver solder assembly).....	(On application)
14	MI-27793-15	Adaptor, Male (soft solder assembly).....	(On application)
14	MI-27793-16	Adaptor, Male (silver solder assembly).....	(On application)
14	MI-27793-17	Gasket ("O" Ring).....	(On application)
14	MI-27793-18	Marman Clamp	(On application)
14	MI-27793-31	Adaptor (female outer to 6 1/8" 75-ohm Universal Line with male outer).....	(On application)
14	MI-27793-32	Adaptor (female outer to 6 1/8" 75-ohm Universal Line with female outer).....	(On application)
14	MI-27793-33	Adaptor (female outer to 6 1/8" 75-ohm RETMA Line).....	(On application)

VHF COAXIAL TRANSMISSION LINE

1 5/8" HARD COPPER 51.5-OHM STEATITE COAXIAL LINE AND FITTINGS (MI-19112 Series)

26	MI-19112-1	Transmission Line, 20-ft. lengths, flanged.....	\$ 53.75
26	MI-19112-1-F	Transmission Line, 20-ft. lengths, 1 flange.....	50.10
26	MI-19112-1-NF	Transmission Line, 20-ft. lengths, no flanges.....	46.50
26	MI-19112-2	Coupling, 90° Elbow, flanged.....	32.65
26	MI-19112-2-F	Coupling, 90° Elbow, 1 flange.....	29.00
26	MI-19112-2-NF	Coupling, 90° Elbow, no flanges.....	25.50
26	MI-19112-3	Coupling, 45° Elbow, flanged.....	32.65
26	MI-19112-3-F	Coupling, 45° Elbow, 1 flange.....	29.00
26	MI-19112-3-NF	Coupling, 45° Elbow, no flanges.....	25.50
26	MI-19112-4	Adaptor for Gassed Line.....	11.75
26	MI-19112-5	Gas Stop	30.00
26	MI-19112-6	Reducer Coupling (Gassed).....	31.50
27	MI-19112-7	Reducer Coupling (Ungassed).....	18.00
27	MI-19112-8	Straight Coupling	5.00
27	MI-19112-9	Special Inner Conductor.....	5.65
27	MI-19112-10	"O" Ring Gasket.....	.30
27	MI-19112-11	Inner Connector	1.50

Page	MI Number	Description	Price
27	MI-19112-12	Line Gassing Accessories.....	17.50
27	MI-19112-13	Emergency Cover Plate.....	3.40
27	MI-19112-16	Adaptor	7.40
27	MI-19112-18	Coupling, 90° Mitre Elbow, flanged.....	51.25
27	MI-19112-18-F	Coupling, 90° Mitre Elbow, 1 flange.....	45.00
27	MI-19112-18-NF	Coupling, 90° Mitre Elbow, no flanges.....	39.00
27	MI-19112-19	Hardware Kit	1.05
27	MI-19112-20	Flange, Fixed	5.10
27	MI-19112-21	Flange, Swivel	7.25
27	MI-19112-22	Coupling, 45° Mitre Elbow, flanged.....	50.00
27	MI-19112-22-F	Coupling, 45° Mitre Elbow, 1 flange.....	42.00
27	MI-19112-22-NF	Coupling, 45° Mitre Elbow, no flanges.....	38.00
27	MI-19112-58	Reducer, 1 $\frac{5}{8}$ " Ungassed.....	44.50
27	MI-19112-59	Reducer, 1 $\frac{5}{8}$ " Gassed.....	41.00
27	MI-19112-60	Adaptor for Ungassed Line.....	8.75

3 $\frac{1}{8}$ " HARD COPPER 51.5-OHM STEATITE COAXIAL TRANSMISSION LINE AND FITTINGS (MI-19113 Series)

28	MI-19113-B-1	Transmission Line, 20-ft. lengths, flanged.....	\$ 108.00
28	MI-19113-B-1-F	Transmission Line, 20-ft. lengths, 1 flange.....	99.00
28	MI-19113-B-1-NF	Transmission Line, 20-ft. lengths, no flanges.....	93.00
28	MI-19113-B-1-SF	Transmission Line, 20-ft. lengths, 1 fixed and 1 swivel flange.....	108.50
28	MI-19113-B-2	Coupling, 90° Elbow, 1 fixed and 1 swivel flange.....	50.00
29	MI-19113-B-2-F	Coupling, 90° Elbow, 1 swivel flange.....	40.00
29	MI-19113-B-2-NF	Coupling, 90° Elbow, no flanges.....	32.00
29	MI-19113-B-3	Coupling, 45° Elbow, 1 fixed and 1 swivel flange.....	50.00
29	MI-19113-B-3-F	Coupling, 45° Elbow, 1 swivel flange.....	40.00
29	MI-19113-B-3-NF	Coupling, 45° Elbow, no flanges.....	32.00
29	MI-19113-C-4	Adaptor for Gassed Line.....	26.00
29	MI-19113-C-5	Gas Stop	44.50
29	MI-19113-C-6	Reducer Coupling 3 $\frac{1}{8}$ " to 1 $\frac{5}{8}$ " Gassed Line.....	32.00
29	MI-19113-C-7	Reducer Coupling 3 $\frac{1}{8}$ " to 1 $\frac{5}{8}$ " Ungassed Line.....	17.50
29	MI-19113-C-8	Straight Coupling	9.75
29	MI-19113-C-9	Special Inner Conductor.....	19.50
29	MI-19113-C-10	"O" Ring Gasket.....	.38
29	MI-19113-C-11	Inner Connector	1.75
29	MI-19113-C-13	Cover Plate	7.50
29	MI-19113-C-17	End Seal	40.00
30	MI-19113-C-18	Coupling, 90° Mitre Elbow, flanged.....	62.50
30	MI-19113-C-18-F	Coupling, 90° Mitre Elbow, 1 flange.....	55.00
30	MI-19113-C-18-NF	Coupling, 90° Mitre Elbow, no flanges.....	48.00
30	MI-19113-C-19	Hardware Kit	1.50
30	MI-19113-C-20	Fixed Flange	7.65
30	MI-19113-C-21	Swivel Flange	11.00
30	MI-19113-C-22	Coupling, 45° Mitre Elbow, flanged.....	62.50
30	MI-19113-C-22-F	Coupling, 45° Mitre Elbow, 1 flange.....	64.00
30	MI-19113-C-22-NF	Coupling, 45° Mitre Elbow, no flanges.....	47.00
30	MI-19113-C-51	Cut-Off Gauge	25.00
30	MI-19113-C-53	Transformer, 51.5-ohm to 50-ohm, channels 7 to 13.....	65.00
30	MI-19113-C-54	Cut-Off Gauge	25.00
30	MI-19113-C-55	Solder-Type Adaptor	25.50
30	MI-19113-C-58	Reducer	98.00
30	MI-19113-C-60	Flanged Adaptor for Ungassed Line.....	26.00

**SPECIAL 3/8" HARD COPPER 50-OHM TEFLON INDOOR TYPE TRANSMISSION LINE
AND FITTINGS (MI-27912 Series)**

Page	MI Number	Description	Price
32	MI-27912-1	Transmission Line, 20-ft. lengths, unflanged.....	(On application)
32	MI-27912-2	Coupling, 90° Mitre Elbow, no flanges.....	(On application)
32	MI-27912-3	Coupling, 45° Mitre Elbow, no flanges.....	(On application)
32	MI-27912-4	Coupling	(On application)
32	MI-27912-5	Inner Connector	(On application)
32	MI-27912-6	Adjustable Clamp	(On application)
32	MI-27912-7	Adaptor, Female	(On application)
32	MI-27912-8	Adaptor, Male	(On application)
32	MI-27912-9	Reducer	(On application)

6 1/8" HARD COPPER 51.5-OHM STEATITE COAXIAL LINE AND FITTINGS (MI-19314-C Series)

33	MI-19314-C-1A	Transmission Line, 10-ft. lengths, no flanges.....	\$ 132.00
33	MI-19314-C-1B	Transmission Line, 19-ft. lengths, flanged.....	280.00
33	MI-19314-C-1C	Transmission Line, 20-ft. lengths, flanged.....	282.00
33	MI-19314-C-1D	Transmission Line, 20-ft. lengths, 1 fixed and 1 swivel flange.....	286.00
33	MI-19314-C-1E	Transmission line, 19-ft. lengths, 1 fixed and 1 swivel flange.....	286.00
33	MI-19314-C-1F	Transmission Line, 20-ft. lengths, 1 flange.....	266.00
33	MI-19314-C-4	Reducer Coupling, 6 1/8" to 3 1/8" Gassed Line.....	125.75
33	MI-19314-C-5	Inner Connector	13.75
33	MI-19314-C-7	Straight Coupling	30.25
33	MI-19314-C-8	Cover Plate	25.00
33	MI-19314-C-9	"O" Ring Gasket.....	.95
33	MI-19314-C-10	Hardware Kit	3.20
33	MI-19314-C-11	Fixed Flange	14.35
35	MI-19314-C-12	Swivel Flange	23.00
35	MI-19314-C-13	Reducer Coupling 6 1/8" to 3 1/8" Ungassed Line.....	125.75
35	MI-19314-C-14	Solder Type Adaptor.....	41.50
35	MI-19314-C-16	Cut-Off Gauge	28.00
35	MI-19314-C-18	Coupling, 90° Mitre Elbow, flanged.....	150.25
35	MI-19314-C-18-F	Coupling, 90° Mitre Elbow, 1 flange.....	136.25
35	MI-19314-C-18-NF	Coupling, 90° Mitre Elbow, no flanges.....	121.00
35	MI-19314-C-22	Coupling, 45° Mitre Elbow, flanged.....	150.25
35	MI-19314-C-22-F	Coupling, 45° Mitre Elbow, 1 flange.....	136.25
35	MI-19314-C-22-NF	Coupling, 45° Mitre Elbow, no flanges.....	121.00
35	MI-19314-C-23	Special Inner Conductor.....	30.75
35	MI-19314-C-39	Hose Clamp95
35	MI-19314-C-52	Gas Stop	200.00
35	MI-19314-C-53	Tool Kit	200.00

TRANSMISSION LINE ACCESSORIES

FIXED HANGERS

43	MI-19312-41	Fixed Hanger for 1 3/8" Single Line (Clamp on Round Member).....	\$ 13.20
43	MI-19312-42	Fixed Hanger for 1 3/8" Single Line (Clamp on Round Member).....	13.20
43	MI-19313-41	Fixed Hanger for 3 1/8" Single Line (Clamp on Round Member).....	16.00
43	MI-19313-42	Fixed Hanger for 3 1/8" Single Line (Clamp on Round Member).....	18.50
43	MI-19314-44	Fixed Hanger for 6 1/8" Single Line (Mount Through Hole).....	16.75
43	MI-27900-44	Fixed Hanger for 9 3/16" Single Line (Mount Through Hole).....	On Application
43	MI-19312-44	Fixed Hanger for 1 3/8" Single Line (Mount Through Hole).....	8.80
43	MI-19312-47	Fixed Hanger for 1 3/8" Single Line (Mount Through Hole).....	9.05
43	MI-19313-44	Fixed Hanger for 3 1/8" Single Line (Mount Through Hole).....	10.75
43	MI-19313-47	Fixed Hanger for 3 1/8" Single Line (Mount Through Hole).....	10.75
43	MI-19112-15	Fixed Hanger for 1 3/8" Dual Line (Mount Through Hole).....	9.50
43	MI-19112-49	Fixed Hanger for 1 3/8" Dual Line (Mount Through Hole).....	12.00
43	MI-19113-15	Fixed Hanger for 3 1/8" Dual Line (Mount Through Hole).....	10.50
43	MI-19113-49	Fixed Hanger for 3 1/8" Dual Line (Mount Through Hole).....	26.50

Page	MI Number	Description	Price
43	MI-19312-40	Fixed Hanger for 1 $\frac{5}{8}$ " Single Line (Clamp on Flat Member).....	15.30
43	MI-19313-40	Fixed Hanger for 3 $\frac{1}{8}$ " Single Line (Clamp on Flat Member).....	18.00
43	MI-19312-43	Fixed Hanger for 1 $\frac{5}{8}$ " Single Line (Clamp on Angular Member)....	15.50
43	MI-19313-43	Fixed Hanger for 3 $\frac{1}{8}$ " Single Line (Clamp on Angular Member)....	15.40

EXPANSION HANGERS

45	MI-19312-23	Expansion Hanger for 1 $\frac{5}{8}$ " Single Line (Clamp on Round Member)	14.85
45	MI-19312-24	Expansion Hanger for 1 $\frac{5}{8}$ " Single Line (Clamp on Round Member)	14.85
45	MI-19312-26	Expansion Hanger for 1 $\frac{5}{8}$ " Single Line (Clamp on Round Member)	14.85
45	MI-19312-27	Expansion Hanger for 1 $\frac{5}{8}$ " Single Line (Clamp on Round Member)	14.85
45	MI-19312-25	Expansion Hanger for 1 $\frac{5}{8}$ " Single Line (Clamp on Round Member)	19.60
45	MI-19312-28	Expansion Hanger for 1 $\frac{5}{8}$ " Single Line (Clamp on Round Member)	19.60
45	MI-19313-23	Expansion Hanger for 3 $\frac{1}{8}$ " Single Line (Clamp on Round Member)	17.30
45	MI-19313-24	Expansion Hanger for 3 $\frac{1}{8}$ " Single Line (Clamp on Round Member)	17.30
45	MI-19313-26	Expansion Hanger for 3 $\frac{1}{8}$ " Single Line (Clamp on Round Member)	17.30
45	MI-19313-27	Expansion Hanger for 3 $\frac{1}{8}$ " Single Line (Clamp on Round Member)	17.30
45	MI-19313-25	Expansion Hanger for 3 $\frac{1}{8}$ " Single Line (Clamp on Round Member)	23.10
45	MI-19313-28	Expansion Hanger for 3 $\frac{1}{8}$ " Single Line (Clamp on Round Member)	23.10
45	MI-19313-32	Expansion Hanger for 6 $\frac{1}{8}$ " Single Line (Mount Through Hole).....	29.25
45	MI-27900-32	Expansion Hanger for 9 $\frac{3}{16}$ " Single Line (Mount Through Hole).....	55.00
45	MI-19314-34	Expansion Hanger for 6 $\frac{1}{8}$ " Single Line (Mount Through Hole).....	36.25
45	MI-27900-34	Expansion Hanger for 9 $\frac{3}{16}$ " Single Line (Mount Through Hole).....	87.00
45	MI-19312-32	Expansion Hanger for 1 $\frac{5}{8}$ " Single Line (Mount Through Hole).....	10.45
45	MI-19312-33	Expansion Hanger for 1 $\frac{5}{8}$ " Single Line (Mount Through Hole).....	10.45
45	MI-19312-34	Expansion Hanger for 3 $\frac{1}{8}$ " Single Line (Mount Through Hole).....	17.50
45	MI-19313-32	Expansion Hanger for 1 $\frac{5}{8}$ " Single Line (Mount Through Hole).....	16.45
45	MI-19313-33	Expansion Hanger for 3 $\frac{1}{8}$ " Single Line (Mount Through Hole).....	11.75
45	MI-19313-34	Expansion Hanger for 3 $\frac{1}{8}$ " Single Line (Mount Through Hole).....	17.60
45	MI-19112-14	Expansion Hanger for 1 $\frac{5}{8}$ " Dual Line (Mount Through Hole).....	20.50
45	MI-19112-48	Expansion Hanger for 1 $\frac{5}{8}$ " Dual Line (Mount Through Hole).....	22.50
45	MI-19113-14	Expansion Hanger for 3 $\frac{1}{8}$ " Dual Line (Mount Through Hole).....	22.50
45	MI-19113-48	Expansion Hanger for 3 $\frac{1}{8}$ " Dual Line (Mount Through Hole).....	39.00
45	MI-19312-20	Expansion Hanger for 1 $\frac{5}{8}$ " Single Line (Clamp on Flat Members)	16.50
45	MI-19312-21	Expansion Hanger for 1 $\frac{5}{8}$ " Single Line (Clamp on Flat Members)	16.50
45	MI-19312-22	Expansion Hanger for 1 $\frac{5}{8}$ " Single Line (Clamp on Flat Members)	23.00
45	MI-19313-20	Expansion Hanger for 3 $\frac{1}{8}$ " Single Line (Clamp on Flat Members)	19.75
45	MI-19313-21	Expansion Hanger for 3 $\frac{1}{8}$ " Single Line (Clamp on Flat Members)	19.75
45	MI-19313-22	Expansion Hanger for 3 $\frac{1}{8}$ " Single Line (Clamp on Flat Members)	26.50
45	MI-19312-29	Expansion Hanger for 1 $\frac{5}{8}$ " Single Line (Clamp on Angular Members).....	16.40
45	MI-19312-30	Expansion Hanger for 1 $\frac{5}{8}$ " Single Line (Clamp on Angular Members).....	16.40
45	MI-19312-31	Expansion Hanger for 1 $\frac{5}{8}$ " Single Line (Clamp on Angular Members).....	23.00
45	MI-19313-29	Expansion Hanger for 3 $\frac{1}{8}$ " Single Line (Clamp on Angular Members).....	20.00
45	MI-19313-30	Expansion Hanger for 3 $\frac{1}{8}$ " Single Line (Clamp on Angular Members).....	20.00
45	MI-19313-31	Expansion Hanger for 1 $\frac{5}{8}$ " Single Line (Clamp on Angular Members).....	27.00

MISCELLANEOUS TRANSMISSION LINE ACCESSORIES

47	MI-19312-17	Horizontal Anchor for Supporting Single Line.....	12.25
47	MI-19313-17	Horizontal Anchor for Supporting 3 $\frac{1}{8}$ " Single Line.....	30.00
47	MI-19314-48	Horizontal Anchor for Supporting 6 $\frac{1}{8}$ " Single Line.....	50.00
47	MI-27900-48	Horizontal Anchor for Supporting 9 $\frac{3}{16}$ " Single Line.....	On Application
47	MI-19312-18	Horizontal Anchor for Supporting 1 $\frac{5}{8}$ " Dual Lines.....	26.00
47	MI-19313-18	Horizontal Anchor for Supporting 3 $\frac{1}{8}$ " Dual Lines.....	44.50
47	MI-19314-49	Horizontal Anchor for Supporting 6 $\frac{1}{8}$ " Dual Lines.....	83.00
47	MI-27900-49	Horizontal Anchor for Supporting 9 $\frac{3}{16}$ " Dual Lines.....	On Application

Page	MI Number	Description	Price
47	MI-19312-35	Horizontal Roller Assembly for 1 $\frac{5}{8}$ " Line.....	7.50
47	MI-19313-35	Horizontal Roller Assembly for 3 $\frac{1}{8}$ " Line.....	13.00
47	MI-19314-35	Horizontal Roller Assembly for 6 $\frac{1}{8}$ " Line.....	39.00
47	MI-27900-35	Horizontal Roller Assembly for 9 $\frac{3}{8}$ " Line.....On Application	
47	MI-19312-36	Lateral Brace for Supporting 1 $\frac{5}{8}$ " Single Line.....	7.60
47	MI-19313-36	Lateral Brace for Supporting 3 $\frac{1}{8}$ " Single Line.....	7.75
47	MI-19314-36	Lateral Brace for Supporting 6 $\frac{1}{8}$ " Single Line.....	9.25
47	MI-27900-36	Lateral Brace for Supporting 9 $\frac{3}{8}$ " Single Line.....	10.75
47	MI-19312-19	Line Spreader for 1 $\frac{5}{8}$ " Lines.....	6.00
47	MI-19313-19	Line Spreader for 3 $\frac{1}{8}$ " Lines.....	8.25
47	MI-19312-37	Swivel Hanger for Supporting 1 $\frac{5}{8}$ " Single Line.....	7.75
47	MI-19312-38	Swivel Hanger for Supporting 1 $\frac{5}{8}$ " Dual Lines.....	12.30
47	MI-19313-37	Swivel Hanger for Supporting 3 $\frac{1}{8}$ " Single Line.....	14.75
47	MI-19313-38	Swivel Hanger for Supporting 3 $\frac{1}{8}$ " Dual Lines.....	17.00
47	MI-19314-50	Three-Point Expansion Hanger for 6 $\frac{1}{4}$ " Single Line.....	30.75
47	MI-27900-50	Three-Point Expansion Hanger for 9 $\frac{3}{8}$ " Single Line.....(On Application)	
47	MI-19314-51	Three-Point Expansion Hanger for 6 $\frac{1}{4}$ " Dual Lines.....	61.50
47	MI-27900-51	Three Point Expansion Hanger for 9 $\frac{3}{8}$ " Dual Lines.....(On Application)	
47	MI-19113-16	Extension Kit for Mounting Grounded Dual Hangers.....	2.50

INDOOR TRANSMISSION LINE HANGERS

51	MI-27700	Hanger Kit for 3 $\frac{1}{4}$ " Line (Attaches to line for Ceiling Support at six [6] points).....	8.60
51	MI-27701	Hanger Kit for 6 $\frac{1}{8}$ " Line (Attaches to line for Ceiling Support at six [6] points).....	9.50
51	MI-27702	Hanger Wall Bracket Kit.....	10.25
51	MI-27703	Hanger Wall Bracket Extension Kit.....	3.00
51	MI-27704	Mounting Kit (for attachment to soft surfaces).....	3.10
51	MI-27705	Hanger Kit (for attachment to "I" Beam).....	2.75
51	MI-27706	Hanger Kit (for attachment to Concrete Surfaces).....	1.85

DEHYDRATOR EQUIPMENT

54	MI-27348-1	1 Cu. Ft. Double Desiccant Dehydrator.....	512.00
54	MI-27348-2	1.5 Cu. Ft. Double Desiccant Dehydrator.....	990.00
54	MI-27348-3	2 Cu. Ft. Double Desiccant Dehydrator.....	1,392.00
54	MI-27348-4	1 Cu. Ft. Single Desiccant Dehydrator.....	330.00
56	MI-19112-12	Dual Line Gassing Accessories Kit.....	17.50
56	MI-19315-1	50-ft. Coil of $\frac{1}{4}$ " O.D. Soft Drawn Copper Tubing.....(ft.)	.18
56	MI-19315-2	90° Elbow, $\frac{1}{8}$ " x $\frac{1}{8}$ " IPS.....	.30
56	MI-19315-3	Flare Fitting, Female.....	.43
56	MI-19315-4	Flare Fitting, Male.....	.43
56	MI-19314-5	Flare Fitting Union Nut, $\frac{1}{16}$ "-20 Thread.....	.25
56	MI-19315-6	Flare Fitting, Female.....	.43
56	MI-19315-7	Pipe Plug, $\frac{1}{8}$ " IPS.....	.25
56	MI-19315-8	Pipe Plug, $\frac{1}{4}$ " IPS.....	.25
56	MI-19315-9	Nipple, Brass $\frac{1}{4}$ " IPS, 1 $\frac{1}{2}$ " long.....	.20
56	MI-19315-10	Precision Needle Valve, $\frac{1}{8}$ " IPS Thread.....	2.37
56	MI-19315-11	Gas Admission Valve.....	.72
56	MI-19315-12	Bleeder Valve.....	1.10
56	MI-19315-13	Brass Tee Fitting, $\frac{1}{8}$ " x $\frac{1}{8}$ " x $\frac{1}{8}$ " IPS.....	.43
56	MI-19315-14	Pressure Gauge.....	2.85
56	MI-19315-15	Distribution Manifold.....	7.55
56	MI-19315-16	Service Tee, $\frac{1}{8}$ ".....	.43
56	MI-19315-17	Fitting Nipple, $\frac{1}{4}$ " IPS Brass.....	.17
56	MI-19315-18	Brass Reducing Bushing.....	.41
56	MI-19315-20	Kit of Gassing Accessories.....	12.00
56	MI-19315-21	Two-Stage Pressure Reducing Regulator for Nitrogen-Gassed Lines	56.50
56	MI-19315-22	Single Stage Pressure Reducing Regulator for Nitrogen-Gassed Lines	41.00

Page	MI Number	Description	Price
56	MI-19315-23	Reducing Relief Valve.....	11.65
56	MI-19315-24	Kit of Accessories for Gassing Single Line with Nitrogen.....	68.00
56	MI-19315-25	Flared Double-Ended Union Fitting.....	.99
56	MI-19315-26	Plain Pipe Coupling.....	17.50
56	MI-19315-27	Dehydrator Hose with snap-on connectors..... (On Application)	
56	MI-19315-28	Flaring and Cutting Tool Kit..... (On Application)	

POWER SWITCHING

57	MI-27330	VHF Automatic Coaxial Switch, 51.5-ohm Line.....	\$ 550.00
57	MI-27335	VHF Automatic Coaxial Switch, 50-ohm Line.....	550.00
58	MI-27717	3 $\frac{1}{8}$ " 3-Pole, Sleeve Type Manual Transfer Panel, 51.5-ohms.....	290.00
58	MI-27718	3 $\frac{1}{8}$ " 7-Pole, Sleeve Type Manual Transfer Panel, 51.5-ohms.....	640.00
58	MI-27719	6 $\frac{1}{8}$ " 3-Pole, Sleeve Type Manual Transfer Panel, 51.5-ohms.....	790.00
58	MI-27720	6 $\frac{1}{8}$ " 7-Pole, Sleeve Type Manual Transfer Panel, 51.5-ohms.....	1,270.00
58	MI-27333	3 $\frac{1}{8}$ " 3-Pole, Flange Type Manual Transfer Panel, 50-ohms.....	290.00
58	MI-27334	3 $\frac{1}{8}$ " 7-Pole, Flange Type Manual Transfer Panel, 50-ohms.....	685.00
58	MI-27710	6 $\frac{1}{8}$ " 3-Pole, Flange Type Manual Transfer Panel, 75-ohms.....	780.00
58	MI-27711	6 $\frac{1}{8}$ " 7-Pole, Flange Type Manual Transfer Panel, 75-ohms.....	1,270.00
58	MI-27791-50	3 $\frac{1}{8}$ " 3-Pole, Clamp Type Manual Transfer Panel, 50-ohms (On Application)	
58	MI-27791-51	3 $\frac{1}{8}$ " 7-Pole Clamp Type Manual Transfer Panel, 50-ohms (On Application)	
58	MI-27792-50	6 $\frac{1}{8}$ " 3-Pole, Clamp Type Manual Transfer Panel, 75-ohms (On Application)	
58	MI-27792-51	6 $\frac{1}{8}$ " 7-Pole, Clamp Type Manual Transfer Panel, 75-ohms (On Application)	
58	MI-27912-50	3 $\frac{1}{8}$ " 3-Pole, Indoor Type Manual Transfer Panel, 50-ohms (On Application)	
58	MI-27912-51	3 $\frac{1}{8}$ " 7-Pole, Indoor Type Manual Transfer Panel, 50-ohms (On Application)	
59	MI-27912-52	50-ohm Adaptor for use with MI-27912-50/51..... (On Application)	
59	MI-27337	51.5-ohm Adaptor for use with MI-27717 or MI-27718.....	15.00
59	MI-27709	51.5-ohm Adaptor for use with MI-27719 or MI-27729.....	15.00
59	MI-19089-10	3 $\frac{1}{8}$ " Anchor Connector for use with MI-27333/27334.....	25.25
59	MI-19387-10	6 $\frac{1}{8}$ " Anchor Connector for use with MI-27710/27711.....	51.00

DIRECTIONAL COUPLERS

61	MI-27379	Directional Coupler for use with MI-19089 Transmission Line.....	\$ 206.20
61	MI-27380	Directional Coupler for use with MI-19113 or MI-19313 Pressurized Transmission Line.....	203.00
61	MI-27381	Directional Coupler for use with MI-19113 or MI-19313 Pressurized Transmission Line.....	189.00
61	MI-27382	Directional Coupler for use with MI-19387 Transmission Line.....	256.50
61	MI-27383	Directional Coupler for use with MI-19314-C Pressurized Transmission Line.....	253.50
61	MI-27384	Directional Coupler for use with MI-19314-C Non-pressurized Transmission Line.....	222.50
61	MI-27385	Directional Coupler for use with MI-27791 Transmission Line..... (On Application)	
61	MI-27386	Directional Coupler for use with MI-27912 Transmission Line..... (On Application)	
61	MI-27386	Directional Coupler for use with MI-27792 Transmission Line..... (On Application)	
61	MI-27389	Directional Coupler (less 6 $\frac{1}{8}$ " Coupler Housing).....	168.00
61	MI-29390	Directional Coupler (less 3 $\frac{1}{8}$ " Coupler Housing).....	160.00

BROADCAST EQUIPMENT SALES POLICY

FOREWORD

The present statement sets forth basic conditions under which RCA sells broadcast equipment as described in our catalog, and notes certain supplemental information. This statement does not apply to the sale of tubes or sound film recording equipment, for which separate standard sales and lease policies are in effect.

RCA broadcast equipment is sold directly through RCA Regional representatives, who are familiar with broadcast equipment and related problems.

CONTRACT PROCEDURE

All sales based on orders for transmitters, antennas and custom built or special apparatus and on orders over \$5,000 are made in accordance with the conditions of the RCA Standard Proposal Form for the sale of broadcast equipment and with any agreement stipulated thereon for individual customers.

PRICES

RCA broadcast equipment domestic prices are net f.o.b. factory or warehouse, which is Camden, New Jersey, for most items. These prices do not include any federal, state or local taxes based upon use or measured by sale or use and unless otherwise noted do not include federal excise tax. Any such taxes in effect at the time of shipment will be billed separately or will be included in the prices when required and will be due and payable upon delivery.

RCA's prices do not include installation or installation supervision unless specifically mentioned in a written condition or proposal. Purchaser assumes responsibility for installation and operation of the equipment as well as for obtaining all necessary licenses, permits, etc.

NOTE: The service of factory trained personnel who are specialists in the supervision of the installation of broadcast equipment and its maintenance and repair may be obtained through an order placed with the RCA Service Company, Inc. It is recommended that the advantages of this service be considered at the time of purchase of any major broadcast equipment.

In the case of orders under the Standard Proposal Form the billing prices are based on those prices effective at the date of the order to the extent indicated in the final contract. In the case of orders not under the Standard Proposal Form the billing prices are those prices in effect on the date of shipment.

RCA endeavors to keep its published prices current; however, all published prices are subject to change without notice.

Prices for items marked with a symbol (e) in the price column are estimates only and are subject to adjustment to those in effect on the date of shipment.

In the event the estimated prices quoted herein are exceeded by more than 10% and the billing price cannot be established by mutual agreement prior to shipment, such items may be cancelled without liability to RCA or Purchaser by either party giving written notice to the other.

PAYMENT

Terms of payment are subject to approval of RCA's Credit Department at Camden, New Jersey.

DELIVERY

RCA's delivery of broadcast equipment will be f.o.b. factory or warehouse, which is Camden, New Jersey for most items. The Purchaser shall be responsible for all transportation charges, and shipments will normally be forwarded with shipping charges "collect." As an accommodation, when specifically requested to do so by the Purchaser's order, RCA will prepay transportation charges and invoice them to the Purchaser as a separate item.

Delivery will be made to a carrier specified by the Purchaser, unless none is specified, in which event it will be to a common carrier selected by RCA. In the absence of specific

routing instructions from the purchaser, RCA's judgment with respect to the selection of a route will be final.

As a special service with respect to shipments overland, by inland waterways or by air we carry All Risk Transportation Insurance for the benefit of our Broadcast Equipment customers, and your interests will be amply protected in all shipments of equipment while in transit by the methods indicated above, at no additional expense to you, provided that you inspect all shipments within 15 days after receipt and report within that time in writing any shortages or damages to the carrier and to RCA.

RCA will endeavor to meet delivery schedules but it assumes no liability for damages of whatever kind for delays in delivery. No delays in delivery shall relieve the purchaser of his obligation of performance.

PATENT LICENSES

RCA broadcast equipment is licensed for radio telephone or television broadcast transmission under United States patents owned by RCA or under United States patents under which RCA is licensed.

PATENT PROTECTION

RCA, at its own expense, will defend any suit which may be brought against purchaser for infringement of United States patents by the equipment furnished when sold or used for radio telephone or television broadcast transmission, and in any such suit will satisfy any final award for such infringement. This is upon the condition that purchaser gives RCA prompt notice of such suit and full right and opportunity to conduct the defense thereof, together with full information and all reasonable cooperation, and upon the further condition that the claimed infringement does not result from the combination of the equipment furnished with other equipment, apparatus, or devices not furnished by RCA. No costs or expenses shall be incurred for the account of RCA without its written consent. If purchaser's sale or use of such equipment for radio telephone or television broadcast transmission shall be prevented by permanent injunction, RCA shall substitute for the infringing equipment or parts other equally suitable equipment or parts, or at RCA's option obtain for purchaser the right to sell or continue the use of such equipment, or at RCA's option take back such equipment and refund any sums purchaser has paid RCA therefor, less a reasonable amount for use, damage and obsolescence.

WARRANTY

Except for electronic tubes, which bear their own warranty which accompanies them at the time of their sale, RCA warrants its broadcast equipment to be free from defects in material and workmanship under normal use and service for a period of one year from the date of delivery. RCA's obligations under this warranty are limited to the repair or replacement of defective parts and the shipment of such repaired or replacement parts to the purchaser f.o.b. factory. Equipment furnished by RCA but listed as manufactured by another bears only the warranty given by such other manufacturer. No warranties other than those set forth herein are given or are to be implied with respect to broadcast equipment. In no event is RCA liable for consequential damages.

REPAIRED AND RETURNED APPARATUS

Before an apparatus is returned to RCA for repairs or adjustments shipping instructions and an identifying number should be obtained from the nearest RCA Regional Office. RCA assumes no responsibility for unauthorized returns.

EQUIPMENT MODIFICATIONS AND WITHDRAWALS

RCA reserves the right to make, without notice, modifications of the equipment described in this catalog without affecting its right to sell such equipment under orders based on the catalog description, provided, however, that the modifications shall not materially affect performance. These modifications of equipment may be made by RCA or its suppliers from time to time for reasons such as improvement in performance, simplification in design, or availability of material. RCA also reserves the right to withdraw from sale, without notice, any equipment described in our catalog.

ACCEPTANCE OF ORDER

No order shall be binding upon RCA until accepted by it in writing at Camden, New Jersey, and the banking, negotiation or other use of the down payment shall not constitute an acceptance by RCA. Orders received by Regional Offices will be forwarded promptly to RCA's Camden Office.

