

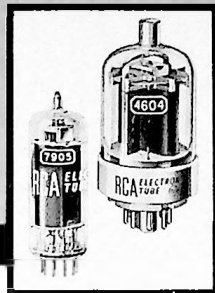

# HAM TIPS



A PUBLICATION OF THE RCA ELECTRON TUBE DIVISION

VOL. 23, NO. 1

©1963, RADIO CORPORATION OF AMERICA

WINTER, 1962-63

## A MOBILE 50-WATT TRANSMITTER FOR THE SIX- AND TWO-METER BANDS

### Part I

By M. R. Adams, WA2ELL, and P. B. Boivin, K2SKK

RCA Electron Tube Division, Harrison, N. J.

A continual increase in the number of technician-class operators is creating new peaks of activity on the six- and two-meter bands. This trend, of course, is most pronounced in metropolitan areas and is evidenced by the quantity and variety of commercial equipment now available for these bands. With the rising popularity of VHF mobile operation, many hams have been seeking new designs to help them achieve higher levels of operating convenience and economy. The use of both six and two meters by Civilian-Defense "RACES" units also makes operation on these bands attractive for emergency use. In a two-part article which will be concluded in the Spring issue, the authors report on a compact, 50-watt amateur mobile transmitter which can be conveniently mounted under an auto dashboard and has a parts-cost which they estimate at no higher than \$100. In addition to bandswitching capability for coverage of both six- and two-meter bands, this versatile performer features RCA's recently announced 4604 and 7905 "quick-heating" beam power tube types for added power economy, and incorporates a variable-frequency oscillator—an advantage seldom, if ever, encountered in today's VHF amateur mobile equipment.

The six- and two-meter frequencies are ideal for mobile installations because of the small antenna size and low power needed for good local coverage. However, the higher frequencies in these bands usually require additional tubes for multipliers and drivers. These additional tubes usually increase the standby power drain on the vehicle battery—unless they are the new quick-heating types recently announced by RCA.

The 50-watt transmitter described in this article is a six- and two-meter plate-modulated AM rig using the new RCA-4604 and -7905

quick-heating beam power tubes. With these tubes, you're on the air in less than one second after you press the microphone push-to-talk button! The only standby power needed in the rf section is that for the conventional VFO heater, which is left on for stability. The push-pull plate modulator delivers that "audio punch" that is so essential to mobile operation and not usually found in screen-grid-modulated finals. In addition, the transmitter and modulator package are designed for dashboard mounting for easy accessibility and convenience of operation.



Front view of WA2ELL's and K2SKK's mobile 50-watt transmitter. Unit measures approximately 12 inches in width, 5 inches in height, and 10 inches in depth.

### Circuit Description

Switching from the six-meter band to the two-meter band presents some problems not encountered at the lower frequencies. In the final stage, for example, the series-tuned tank circuits must be switched without adding excessive lead length on two meters, and yet some means of coupling to the antenna must be provided. Part of the multiplier string must also be switched out of operation on six meters without disrupting the series-connected heater connections on the quick-heating tubes. These and other problems are resolved in the later discussions.

### Variable-Frequency Oscillator

The VFO uses an RCA-6417 miniature beam power tube in a modified series-tuned Clapp oscillator which tunes a basic frequency of 8.0 to 9.0 megacycles. When multiplied, this basic frequency range covers both the six- and two-meter amateur bands. The 8-to-9-

megacycle frequency was chosen as the best compromise between stability and a minimum number of multiplier stages. Frequency stability of the VFO is assured by such design features as regulated screen-grid voltage on the 6417, a double bearing VFO capacitor, a ceramic coil form rigidly mounted on the main chassis, and zero-temperature-coefficient (NPO) capacitors. The plate circuit of the VFO doubles the frequency to cover a range of 16 to 18 megacycles. The VFO output is tuned by capacitor  $C_7$  which is controlled from the front panel.

### Multipliers

The VFO is followed by two triplers and a straight-through driver which increase the frequency to 144 megacycles. The circuits for the triplers V2 and V3 are of conventional design and are quite stable if reasonable care is used in wiring (e.g., the use of shortest possible leads for rf wiring and generous by-passing). Front-panel plate tuning is provided by  $C_{15}$  and  $C_{22}$ . A switch deck ( $S_{2a}$  and  $S_{2b}$ ) located near V2 provides two functions.  $S_{2a}$  switches the output of multiplier V2 directly to the final for six-meter operation, or to the next multiplier, V3, for two-meter operation. The six-meter band is covered as the VFO tunes from 8333 to 9000 kilocycles, or the upper two-thirds of the dial. This basic frequency doubles in the plate circuit of V1, then triples in V2 to cover 50 to 54 megacycles. For two-meter operation, the VFO tunes the

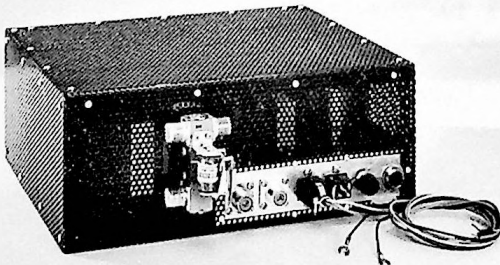

Rear view of new mobile transmitter showing antenna relay, microphone connector, and power connectors.

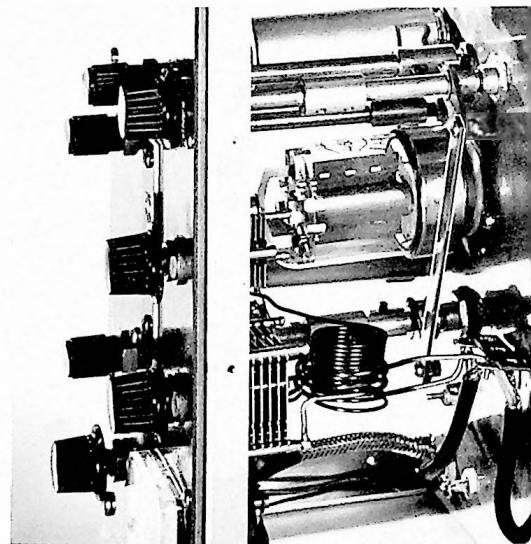

Top view of unit showing detail of bandswitch mechanism.

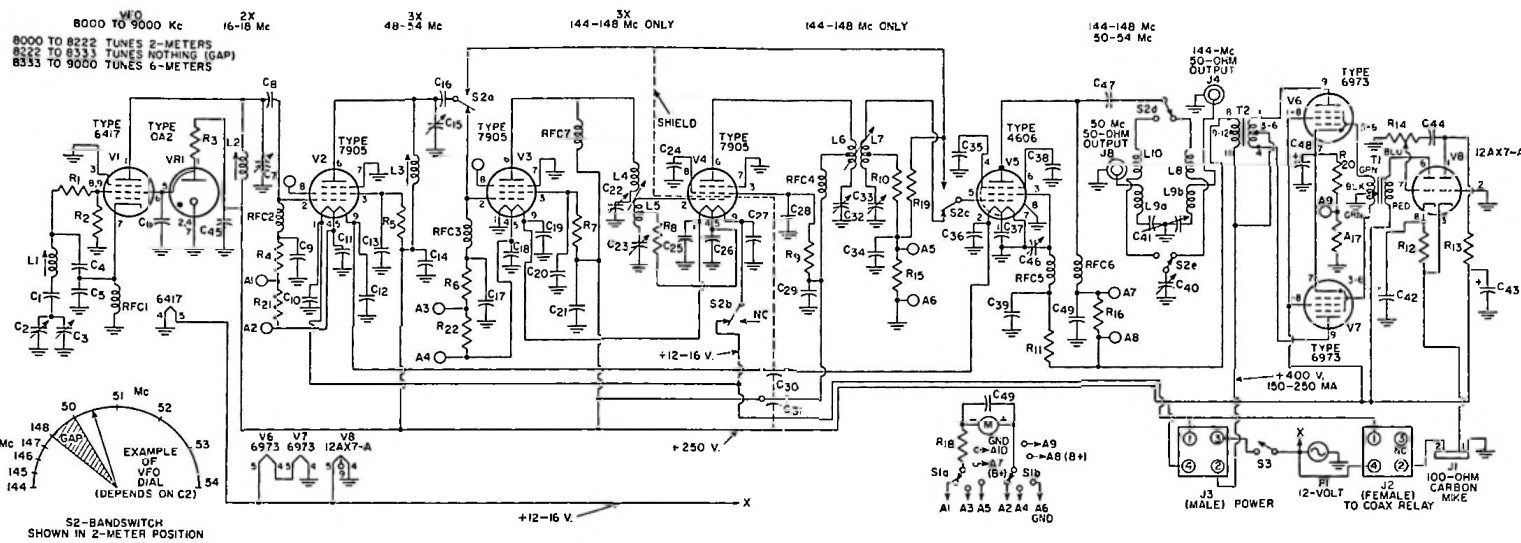

- |   |   |  |   |   |   |
|---|---|--|---|---|---|
| <p>C<sub>1</sub>—220 pf, NPO disc ceramic<br/> C<sub>2</sub>—5-20 pf, double-bearing variable (Hammarlund MC-20-S or equiv.)<br/> C<sub>3</sub>—4-30 pf, NPO ceramic trimmer (Centralab 822-AZ or equiv.)<br/> C<sub>4</sub>, C<sub>5</sub>—390 pf, silver mica<br/> C<sub>6</sub>, C<sub>9</sub>, C<sub>10</sub>, C<sub>11</sub>, C<sub>12</sub>, C<sub>13</sub>, C<sub>14</sub>, C<sub>17</sub>, C<sub>18</sub>, C<sub>19</sub>, C<sub>20</sub>, C<sub>21</sub>, C<sub>24</sub>, C<sub>25</sub>, C<sub>26</sub>, C<sub>27</sub>, C<sub>28</sub>, C<sub>29</sub>, C<sub>34</sub>, C<sub>39</sub>, C<sub>45</sub>, C<sub>49</sub>—0.001 μf 600 WV disc ceramic bypass capacitors<br/> C<sub>7</sub>, C<sub>15</sub>—2.3-14.2 pf, Johnson Midget Variables (15M11 160-107 or equiv.)<br/> C<sub>8</sub>, C<sub>16</sub>—100 pf, disc ceramic<br/> C<sub>22</sub>—1.5-5 pf, Johnson Midget Variable (5M11 160-102 or equiv.)<br/> C<sub>23</sub>, C<sub>33</sub>—1-8 pf, Teflon tubular trimmer (Erie 532-10 or equiv.)<br/> C<sub>30</sub>, C<sub>31</sub>—0.001 μf ceramic feed-thru (Centralab MFT-100 or equiv.)<br/> C<sub>32</sub>—2.8-17.5 pf, variable (Johnson Midget 160-107 or equiv.)</p> | <p>C<sub>25</sub>, C<sub>36</sub>, C<sub>37</sub>, C<sub>38</sub>—0.001 μf button silver mica (Erie 370-FA-102) or equiv.)<br/> C<sub>40</sub>—3.6-15 pf, double-spaced variable (Hammarlund HF-15-X or equiv.)<br/> C<sub>41</sub>—6.3-50 pf, 2-section differential variable (Johnson 167-33 or equiv.)<br/> C<sub>42</sub>—10 μf 50 WV electrolytic<br/> C<sub>43</sub>—8 μf 450 WV electrolytic<br/> C<sub>44</sub>—0.01 μf 600 WV paper<br/> C<sub>46</sub>—5-80 pf, mica trimmer (Arco 462 or equiv.)<br/> C<sub>47</sub>—0.001 μf 2000 WV transmitting mica<br/> C<sub>48</sub>—25 μf 50 WV electrolytic<br/> J<sub>1</sub>—2-wire &amp; shield microphone jack (Amphenol 80-PC2F or equiv.)<br/> J<sub>2</sub>—Cinch-Jones 4-terminal female (261-12-04-010 or equiv.)<br/> J<sub>3</sub>—Cinch-Jones 4-terminal male (261-11-04-010 or equiv.)</p> | <p>J<sub>4</sub>, J<sub>8</sub>—Coaxial cable connector (Amphenol SO-239A or equiv.)<br/> J<sub>5</sub>, J<sub>6</sub>, J<sub>7</sub>—Connectors part of coaxial relay<br/> L<sub>1</sub>—32 turns of No. 24 enamelled wire, 1/16-inch long, 1/2-inch ceramic CTC PLS-7-2C4L slug form<br/> L<sub>2</sub>—26 turns of No. 28 enamelled wire, 3/8-inch long, 1/4-inch ceramic CTC slug form CTC PLS-6-2C4L<br/> L<sub>3</sub>—7 turns of No. 24 enamelled wire, 5/16-inch long, 1/4-inch ceramic CTC slug form CTC PLS-6-2C4L<br/> L<sub>4</sub>—4 1/2 turns of No. 18 enamelled wire, 3/16-inch diameter, 1/2-inch long<br/> L<sub>5</sub>—4 1/2 turns of No. 18 enamelled wire, 3/16-inch diameter, 3/8-inch long, center-tapped for R<sub>8</sub><br/> L<sub>6</sub>—3 turns of No. 20 enamelled wire, 1/2-inch diameter, 3/8-inch long, center-tapped for RFC<sub>4</sub></p> | <p>L<sub>7</sub>—3 turns of No. 20 enamelled wire, 1/2-inch diameter, 3/8-inch long, center-tapped for R<sub>10</sub><br/> L<sub>8</sub>—2 turns of No. 14 enamelled wire, 1 1/16-inch diameter, 3/8-inch long, wound close-space on 3/8-inch mandrel, released and stretched to length<br/> L<sub>9a</sub>, L<sub>9b</sub>—2 turns of No. 14 enamelled wire, 1 1/16-inch diameter, 3/8-inch long<br/> L<sub>10</sub>—11 turns of No. 16 enamelled wire, 1 1/16-inch diameter, close wound 7/8-inch long<br/> M—Meter, 1 ma full-scale<br/> P<sub>1</sub>—Microphone plug (Amphenol 80-MC2M or equiv.)<br/> P<sub>2</sub>—Cinch-Jones cable clamp (261-11-04-030 or equiv.)<br/> P<sub>3</sub>—Cinch-Jones cable clamp (261-12-04-030 or equiv.)<br/> P<sub>4</sub>, P<sub>5</sub>, P<sub>6</sub>, P<sub>7</sub>—Coaxial cable connector (Amphenol 83-1SP) (RG-58/U inserts 83-168 3/16-inch)</p> | <p>PL<sub>1</sub>—Bayonette pilot bulb socket and red jewel indicator<br/> R<sub>1</sub>—68 ohm, 1/2 watt<br/> R<sub>2</sub>, R<sub>13</sub>—47 K, 1/2 watt<br/> R<sub>3</sub>—5 K, 10 watt, wire-wound<br/> R<sub>4</sub>, R<sub>6</sub>—56 K, 1/2 watt<br/> R<sub>5</sub>, R<sub>7</sub>, R<sub>9</sub>—15 K, 1/2 watt<br/> R<sub>8</sub>, R<sub>10</sub>, R<sub>19</sub>—18 K, 1/2 watt<br/> R<sub>11</sub>—18.5 K, 3 watt (3-56 K, 1 watt in parallel)<br/> R<sub>12</sub>—1 K, 1 watt<br/> R<sub>14</sub>—1/2 megohm potentiometer<br/> R<sub>15</sub>, R<sub>21</sub>, R<sub>22</sub>—470 ohm, 1/2 watt<br/> R<sub>16</sub>, R<sub>17</sub>—10 ohm, 1/2 watt<br/> R<sub>18</sub>—1800 ohm, 1/2 watt<br/> R<sub>20</sub>—300 ohm, 10 watt<br/> RFC<sub>1</sub>, RFC<sub>2</sub>, RFC<sub>3</sub>—750 microhenry<br/> RFC<sub>4</sub>, RFC<sub>6</sub>, RFC<sub>7</sub>—Ohmite Z-144 or equiv.<br/> RFC<sub>5</sub>—Ohmite Z-50 or equiv.</p> | <p>RY<sub>1</sub>—Advance coaxial relay, CE/IC2C/12VD (12-volt DC coil and auxiliary contacts)<br/> RY<sub>2</sub>—Potter &amp; Brumfield SPST Relay MR3D or equiv.<br/> S<sub>1</sub>—DP5T rotary wafer switch, non-shorting (Centralab PA-1003 or equiv.)<br/> S<sub>2a</sub>, S<sub>2b</sub>, S<sub>2c</sub>, S<sub>2d</sub>, S<sub>2e</sub>—Centralab SPDT contacts on three separate ceramic wafers (miniatures) SEE TEXT<br/> S<sub>3</sub>—SPST toggle switch<br/> T<sub>1</sub>—Driver transformer, 10 K plate to PP grids, 3:1 pri. to 1/2 sec. (Stancor A-4723 or equiv.)<br/> T<sub>2</sub>—Modulation transformer, Stancor A-3892 poly-pedance 150 ma<br/> Miscellaneous—Microphone, Astatic Model 10M5A carbon button with PTT switch (or equiv.); National MCN VFO dial</p> |
|---|---|--|---|---|---|

Figure 1: Schematic diagram and parts list of WA2ELL's and K2SKK's low-battery-drain mobile transmitter.

lower one-third of the dial, or 8000 to 8222 kilocycles. This basic frequency is then doubled in the plate circuit of V1 and tripled by V2 to a frequency of 48 to 49.3 megacycles. The output of V2 is switched by S<sub>2a</sub> to V3 where the frequency is again tripled to cover a range of 144 to 148 megacycles to drive V4, the straight-through driver for the final. In the six-meter position, S<sub>2b</sub> disconnects the filament power to the two-meter tripler and driver (V3 and V4), which are not used, thereby leaving the filaments of V2 and V5 in series for six-meter operation. (Note that reference is made to "filaments" of the 7905 and 4604 quick-heating tubes. These tubes are fil-

amentary-cathode types and must be treated as such with respect to cathode dc and rf potentials.)

#### Driver

The driver is a straight-through amplifier which provides adequate power between 144 and 148 megacycles to drive the 4604 final amplifier. The 7905 does not provide sufficient output—when used as a doubler-driver at two-meter frequencies—to drive the 4604 to the required 2 milliamperes grid current. V4 must be shielded across the socket to prevent self-oscillation. The series-tuned circuits in the plate and grid are not switched because

they are only used for two-meter operation. Neutralizing should not be necessary when a straddling shield is used across the socket.

#### Final Amplifier

The final amplifier is a plate-modulated single-ended stage utilizing the RCA-4604, which is similar in ratings to the popular 6146. The 4604 uses directly heated filaments for the quick-heating feature. From a cold start, this tube and the 7905 drivers and multipliers reach approximately 90% power output within one second after application of filament voltage. The filament is specifically designed to withstand the normal voltage

variations encountered in mobile use. The grid circuit is series-tuned for two meters and sufficient reserve drive is available from V2 to utilize an untuned grid-No. 1 circuit on six meters. This arrangement simplifies the switching and reduces the number of components required.

The plate circuit is series-tuned on both six- and two-meter bands. One tuning capacitor (C<sub>40</sub>) is switched from one tank coil to the other by one handswitch deck. Two separate links (L<sub>0a</sub> and L<sub>0b</sub>) are used in conjunction with two separate antenna SO-239 jacks at the rear of the transmitter. Each separate link is series-tuned by one-half of a two-section

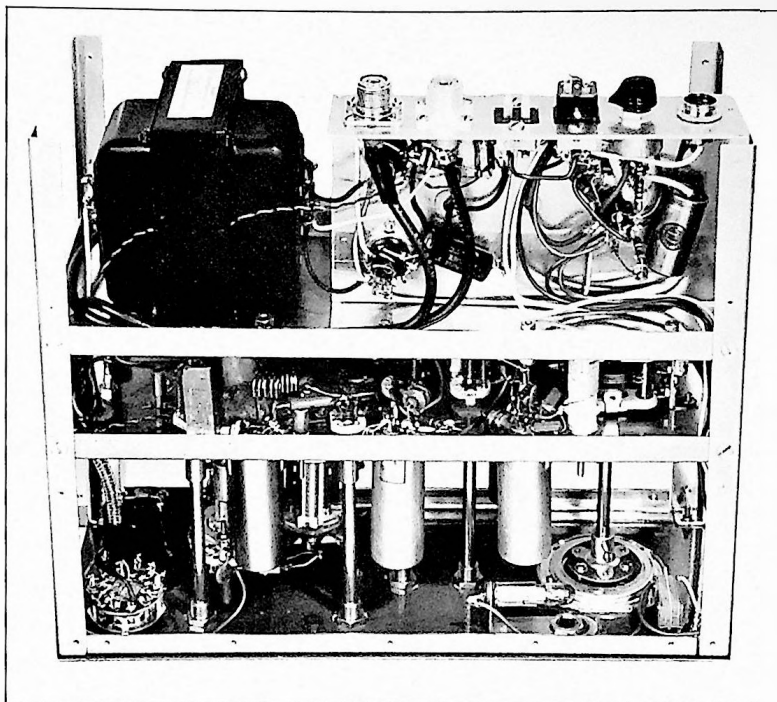

Bottom view showing modulator construction and rf section.

differential capacitor ( $C_{11}$ ) which is used for antenna loading. This arrangement permits the combination of two functions in one front-panel control. Separate antenna jacks are feasible because the same mobile antenna is rarely used on both six- and two-meter bands. The 4604 is neutralized by a tuned screen-grid network ( $RFC_5$  and  $C_{16}$ ).

### Modulators

The RCA-6973 modulators deliver 20 watts of peak power for plate modulation of the final. At the low voltages used in this transmitter, this output is adequate for 100% modulation. Cathode bias in the modulator eliminates the need for a negative fixed-bias supply — an important feature because this type of supply is not always readily available in mobile installations. The speech amplifier (V8) is designed for a high-output carbon microphone. (A crystal microphone would require an additional triode for amplification ahead of V8.) The speech-amplifier-and-modulator circuit is conventional and requires no special precautions in wiring. Because the 6973's become hot in operation, they should not be covered by a tube shield. A clip should be used to hold the tubes in the sockets. V8 requires a conventional tube shield.

### Metering

A five-position switch ( $S_1$ ) is used with a 0-1 milliamperemeter to read final plate and grid currents, modulator cathode current, and multiplier grid currents. The value of the series-multiplier resistor ( $R_{18}$ ) depends on the internal resistance of the meter and the full-scale sensitivity desired. The arrange-

Top view of 50-watt bandswitching transmitter showing modulator layout and final tank-circuit components.

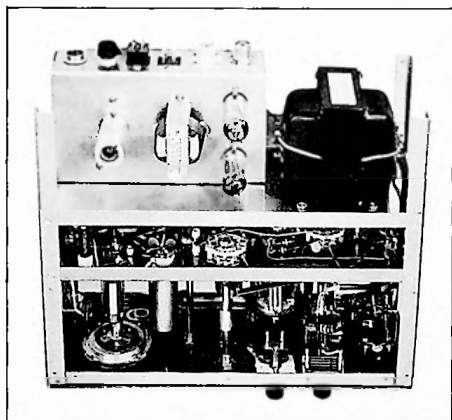

ment used in this transmitter utilizes the meter as a voltmeter to measure the voltage drop across resistors in series with the plate circuit in each stage. In this way, circuit disturbance is kept to a minimum since the metering resistors are always in the circuit. The values in this circuit provide a full-scale sensitivity of 200 milliamperes for plate-current readings and 2 milliamperes for grid-current readings. Both legs of the meter circuit are switched together because there is B+ voltage on both sides of the metering resistor in some positions. The switch itself is mounted on the chassis and is operated by a shaft extending to the front panel. This arrangement keeps leads to the switch short and prevents stray coupling to the final tank coils, so that the possibility of parasitic oscillations is minimized.

#### Transmitter Power Requirements

The transmitter-modulator combination is designed to operate from a supply that delivers approximately 300 milliamperes at 400 volts and 200 milliamperes at 250 volts, or a total of approximately 170 watts. Because the final and modulator use 400 volts B+, two separate high-voltage supplies are not needed. The total standby power required from the 12-volt dc supply is one ampere when the unit is turned on; during transmission, a current

of 1.85 amperes is required on six meters or 2.5 amperes on two meters. The B+ supply requirements depend on the type of supply used and its conversion efficiency. The actual current drawn by the transmitter at 400 volts is 215 milliamperes with no modulation; however, the power supply must deliver peak currents of up to 300 milliamperes when the final is modulated. The authors use dynamotors already on hand to power this unit. Dynamotors are readily available at very moderate cost from military-surplus jobbers.

#### Auxiliary Antenna and Receiver Switching

During transmit periods, a coaxial relay RY<sub>1</sub> on the rear of the transmitter can be used to mute the receiver as well as switch the antenna lead-in between transmitter and receiver. This relay is operated by the push-to-talk switch on the microphone. Because there are separate jacks for six- and two-meter antennas on the rear of the transmitter, a short piece of coaxial cable must be used between either one of these jacks and the transmitter side of the coaxial relay. This jumper, as well as the antenna, must be changed when bands are changed. RG-58/U, 50-ohm coaxial cable is usually preferred for mobile work. Should the builder desire further flexibility, another coaxial relay can be utilized externally to perform the function of switching the jumper.

Information furnished by the Radio Corporation of America is believed to be accurate and reliable. However, no responsibility is assumed by RCA for its use; nor for any in-

fringements of patents or other rights of third parties which may result from its use. No license is granted by implication or otherwise under any patent or patent rights of RCA.



From your local  
RCA distributor,  
headquarters for  
RCA receiving  
and power tubes.

RCA HAM TIPS  
is published by the  
RCA Electron Tube  
Division, Harrison,  
N. J. It is available  
free of charge from  
RCA distributors.

STATION WFDF  
GARLAND AT FIRST AVE  
FLINT 2 MICH RS

WHEN MAILING  
PLACE POSTAGE HERE

