

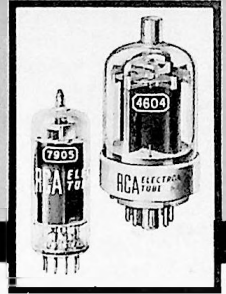

HAM TIPS



A PUBLICATION OF THE RCA ELECTRON TUBE DIVISION

VOL. 23, NO. 2

©1963, RADIO CORPORATION OF AMERICA

SPRING, 1963

A MOBILE 50-WATT TRANSMITTER FOR THE SIX- AND TWO-METER BANDS

Part II

By M. R. Adams, WA2ELL, and P. B. Boivin, K2SKK

RCA Electron Tube Division, Harrison, N. J.

The Winter, 1962-1963, issue of HAM TIPS presented the first installment of a two-part article on a compact, mobile-type 50-watt amateur bandswitching transmitter designed for coverage of the six- and two-meter bands and employing RCA "quick-heating" tube types 4604 and 7905 for added power economy. In that issue, the authors covered such considerations as circuit description, variable-frequency oscillator, multipliers, driver, final amplifier, modulators, metering, transmitter power requirements, and auxiliary antenna and receiver switching. The article is now concluded with a discussion of chassis construction and layout, bandswitching details, capacitor-mounting details, VFO design, driver shielding and construction details, final-amplifier layout, modulator details, VFO calibration and alignment, alignment procedure for multipliers and driver, and general conclusions and installation tips.

Chassis Construction and Layout

Templates for the chassis layout are shown in Figures 3, 4, and 5. The main chassis is made of 20-gauge sheet brass to facilitate ground connections. The socket straddle shield for V4 is fabricated from 24-gauge copper. Aluminum angle stock ($\frac{1}{2}$ -inch by $\frac{1}{2}$ -inch) is cut and drilled to tie together the front panel, main chassis, and modulator. Two more pieces of aluminum angle, $\frac{3}{8}$ -inch by $\frac{3}{8}$ -inch, are attached to the top and bottom edges of the front panel to hold the cover. This type of construction results in a finished unit which can be dash-mounted and requires minimum space in the front seat of the vehicle. The use of a perforated sheet-steel cover, which is mounted in two halves, provides easy



Front view of WA2ELL's and K2SKK's mobile 50-watt transmitter. Unit measures approximately 12 inches in width, 5 inches in height, and 10 inches in depth.

access for servicing and allows air to circulate freely. The front panel is fabricated from $\frac{1}{8}$ -inch sheet aluminum. The modulator is a simple channel-shaped chassis cut down from commercially available chassis or constructed from $\frac{1}{16}$ -inch sheet aluminum as shown in Figure 5. The meter hole in the front panel should be cut with a hole cutter in a drill press. (A chassis punch may warp the panel.) All other large holes can be punched with standard chassis punches.

Bandswitching Details

Bandswitching is accomplished by means of a single knob on the front panel. Figure 6 shows the mechanical linkage for this control which operates S_{2a} directly on the main chassis. The steel ball in this deck provides the detent action for all three switches. A crank on the S_{2a} shaft operates a connector bar

which fastens to a similar crank on the common shaft of S_{2c} and S_{2e} . The ball detents in these two ganged switches are removed to decrease the mechanical resistance on the connector bar and at the knob on the front panel. The ganged decks are held in position by the connector bar. An end-to-end shaft-extension coupling having two set screws is available at most parts-suppliers and can be cut in half to make the two cranks for the connector bar. Because the couplings are usually nickel-plated brass, a small $\frac{1}{16}$ -inch sheet-brass tab can be soldered to the end of the coupling to form a crank and to operate the connecting bar (see Figure 6). The nickel plating should be filed off the end to permit soldering.

The deck with S_{2d} and S_{2e} is back-mounted to the rear of the front panel by the two screws that hold the wafer to the switch, rather than by the shaft. Longer, 4-40 machine screws are used, along with two standard $\frac{3}{4}$ -inch spacers which are cut down to $\frac{5}{8}$ -inch. *Care must be taken to line up the front panel and main chassis so that the switch shafts do not bind or place undue pressure on the ceramic wafer sections.* Remember that the S_{2e} section is wired backwards because it turns in the opposite direction to S_{2d} . Because of the close spacing between terminals on these switches, unused contacts which are adjacent to terminals with high rf voltage should be removed by carefully drilling out the rivets. This step is necessary to prevent breakdown and to decrease circuit capacitance. To prevent stray 50-megacycle rf from feeding through to the final, the terminal on S_{2a} which connects to the grid of the final amplifier is grounded when the switch is in the two-meter position. All shaft couplings on this switch should have flats filed on the shaft under the set-screws to maintain proper alignment and indexing on all three decks.

Capacitor-Mounting Details

Tuning capacitors C_7 , C_{15} , C_{22} , and C_{32} are Johnson midjet variable capacitors which mount in a $\frac{1}{4}$ -inch hole and have a $\frac{3}{16}$ -inch-diameter slotted shaft for screwdriver adjustment. These capacitors can be adapted to front-panel tuning by using $\frac{3}{16}$ -inch shaft couplings and extensions. Because these items of hardware are often difficult to obtain, $\frac{3}{16}$ -inch-to- $\frac{1}{4}$ -inch shaft adapters can be used which will allow standard $\frac{1}{4}$ -inch hardware to be used on the front panel. It is suggested that oversized holes be used in the front panel to facilitate proper alignment of switch and capacitor shafts during assembly.

MODIFICATIONS: In the Part I, Page 5, photograph (Winter, 1962-63, issue) showing modulator construction and rf section, the meter switch, S_1 , is shown mounted on the front panel. The authors subsequently modified the transmitter to mount S_1 on the rf chassis with a shaft extension to the front panel, as described in the text. The main rf chassis template (Part II, Figure 4) includes this modification. The modification was made to prevent the meter leads from picking up stray rf from the final tank coil. Also note that in the Part I, Figure 1 schematic diagram, the final amplifier, V5, is incorrectly labeled as 4606 rather than 4604 as described in the text. Also, VFO tube V1 shows the junction of R_1 and R_2 incorrectly connected to the screen grid rather than to the control grid (pins 8 and 9). Multiplier V3 shows pin 8 incorrectly connected to the suppressor grid rather than to its screen grid. On both V2 and V3, socket pin 8 should be tied to pin 3 with a short jumper. Resistor R_{17} is incorrectly shown as A_{17} . Switch S_1 in Parts List (S_{1a} and S_{1b} in schematic diagram) is actually a two-pole, single-wafer, five-position rotary. The ceramic switches (Parts List designations S_{2a} , S_{2b} , S_{2c} , S_{2d} , and S_{2e}) are three Centra-lab miniature type PA-2007's—modified as described in the text.

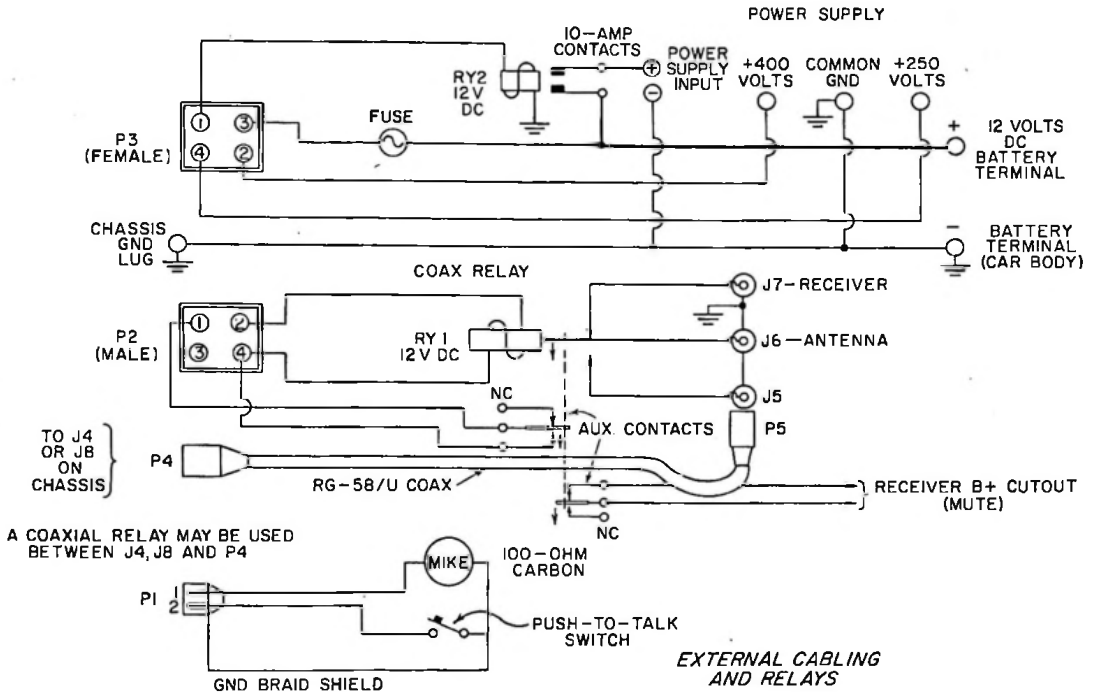

Figure 2: Suggested cabling diagram.

VFO Design

The VFO components should be mounted as rigidly as possible. Care in this respect results in mechanical stability and freedom from FM caused by vibration. The VFO dial calibration favors six meters because the authors planned to use this band most frequently. Some constructors may prefer to add an additional switch in the VFO and two separate capacitors, thus allowing each band to be spread across the dial for easier tuning. Admittedly, crystal control is more stable for mobile operation; however, it is the authors' experience that once a VFO is available, crystals are seldom used. The flexibility of a VFO more than compensates for any difficulty that might be encountered (e.g., drifting out of the narrow passband of certain VHF converters). As a result, the crystal socket, mode switch, extra components, etc., are left out to save space and simplify construction.

Driver Shielding and Construction Details

Because tube V4 operates as a straight-through amplifier at 144 megacycles, adequate isolation between input and output circuits must be provided to prevent oscillation. Neutralization was not necessary with a straddle-shield across the socket to shield the plate-circuit components from the input coils. Oscillation could be a problem with variations in design; therefore, certain units may require neutralization. The shield used in this transmitter is fashioned from tinned-copper flashing and soldered in place so that socket pins 1, 2, and 3 are on the input side and the remainder of the pins are on the output, or plate-circuit, side. If the nine-pin socket has a center lug, it should be soldered to the shield. The size of the shield should be sufficient to separate coils and components as well as socket pins (see Part I photograph showing top view of transmitter and modulator layout and final tank-circuit components).

Final-Amplifier Layout

The grid-No. 1 wiring for final stage must be as close as possible to the bandswitch S_{2c} to keep lead length to a minimum. Bypass capacitors (C_{35} , C_{30} , C_{37} , and C_{38}) in the final are the chassis-mounted, ceramic-button-stand-off type which mount with a 3-48 machine screw. This type of capacitor provides excellent rf grounding with an octal socket. Grid coils for the two-meter band are mounted directly on the bandswitch contacts. The grid-leak bias resistors (R_{10} and R_{19}) are soldered directly to the chassis and as near the V5 socket as possible. The screen-grid neutralizing capacitor C_{40} is an Arco mica compression type and may be rigidly mounted directly across the V5 socket between pins 3 and 7. Plate-circuit components are switched by S_{2d} and S_{2e} . Again, short leads are essential on two meters. The switch-contacts support the tank coils and associated link-coupling coils L_{0n} and L_{0b} . RG-58/U coaxial cable couples directly to each link and carries the output through the main chassis and modulator panels to two separate SO-239 connectors on the rear apron of the modulator. Because these connectors are close to the audio speech amplifier, "hoods" are used to shield the con-

nectors; rf feedback at this point could cause oscillation. The plate-tuning and antenna-loading capacitors are both mounted on the front panel, as well as switch deck S_{2d} and S_{2e} .

Modulator Details

The modulator is conventional and needs only a few comments other than what has already been outlined. Because the microphone connector and audio-gain control are both mounted on the rear apron, input leads to the speech amplifier (V8) are short. Once the audio gain is adjusted for a particular microphone, it is usually unnecessary to change it using a different microphone is used.

The modulator panel is the same size as the main RF chassis and fastens to the angle brackets to complete the assembly. The pre-amplifier chassis and modulation transformer are then mounted to this panel. External power supply and antenna connectors are mounted on the modulator chassis. The antenna-switching coaxial relay is mounted on the rear of the punched-steel cover. A jumper lead completes the connection to the transmitter. Auxiliary contacts on the coaxial antenna relay are used to energize the quick-heating filament string in the rf chassis.

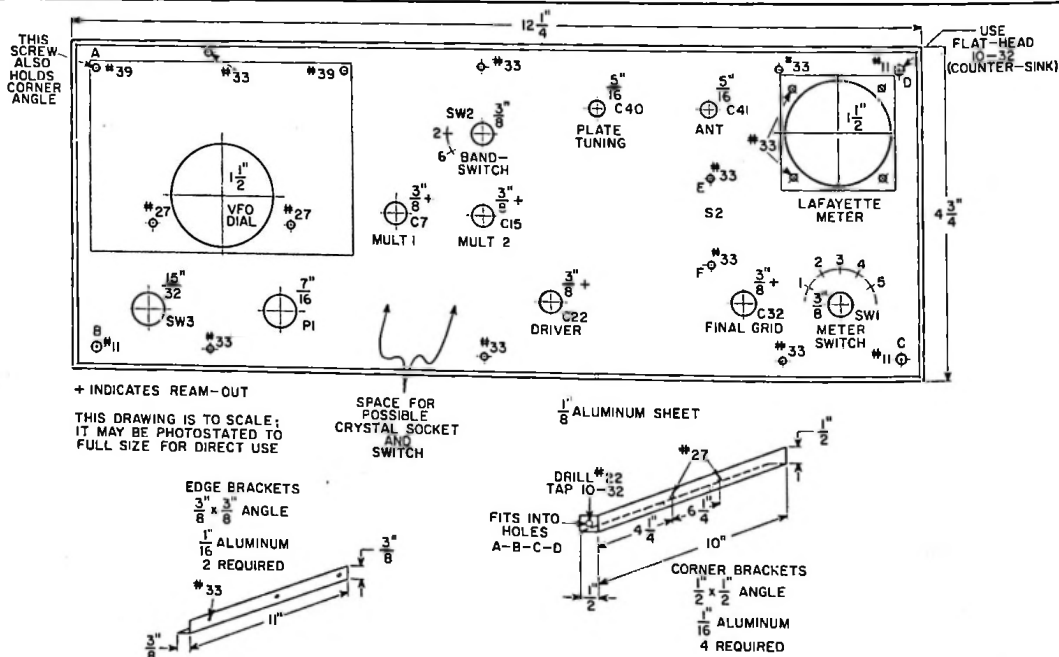

Figure 3: Construction details for front-panel template.

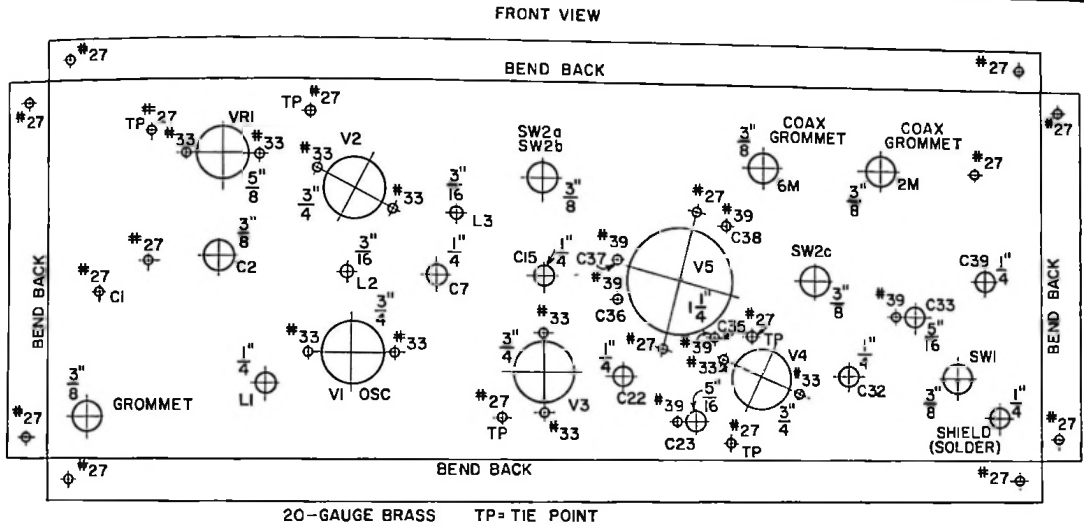

Figure 4: Construction details for main-chassis template.

VFO Calibration and Alignment

The VFO is calibrated from 8.0 to 9.0 megacycles with the aid of a BC-221 frequency meter or a good receiver with a crystal calibrator. The upper two-thirds of the dial scale is numbered with six-meter frequencies which correspond to the sixth harmonic of the basic VFO frequency (50 megacycles is the sixth harmonic of 8333 kilocycles). The lower third of the dial is numbered with two-meter frequencies which correspond to the eighteenth harmonic of the basic VFO frequency (145 megacycles is the eighteenth harmonic of 8055 kilocycles). Subdivisions of each band are placed at half-megacycle intervals.

When the VFO is being aligned, C_2 and C_3 are set at maximum capacitance and the slug in L_1 is tuned until the 8.0-megacycle beat note is heard on the BC-221. C_2 is then tuned to minimum capacitance and checked against the 9.0-megacycle beat note. If the 9.0-megacycle beat is not heard, C_3 is trimmed until it can be heard. C_2 should then be returned to maximum capacitance and the slug in L_1 retrimmed for the 8.0-megacycle beat. This procedure must be repeated several times to find a combination of L_1 and C_3 which covers the 8.0-to-9.0-megacycle range with maximum utilization of dial scale space. It should be remembered that, in aligning any VFO, the

trimmer capacitors are always adjusted at the highest frequency on the dial and the coil slugs are adjusted at the lowest frequency on the dial.

Alignment Procedure for the Multipliers And Driver

When the VFO has been aligned and the power connections to the transmitter completed, the following steps should be followed to tune and align the multipliers and the driver:

1. Remove modulator tubes and disconnect the 400-volt B+ supply *only*; the 250-volt B+ supply is needed for this portion of the line-up.
2. Set hand switch to six meters.
3. Set VFO to 51 megacycles on the dial.
4. Set capacitor C_7 to half-open.
5. With meter switch in position 1, adjust L_2 for maximum grid drive.
6. Set capacitor C_{15} to its half-open position.
7. Place meter switch in position 3 and adjust L_3 for maximum drive at 51 megacycles.

This step completes the alignment for six meters. In future use, the transmitter is tuned up on six meters merely by setting the VFO to the desired frequency and then tuning capacitors C_7 and C_{15} for maximum grid-No. 1 drive. The final stage may then be tuned for maximum output as indicated in steps number 13 and 14 which follow.

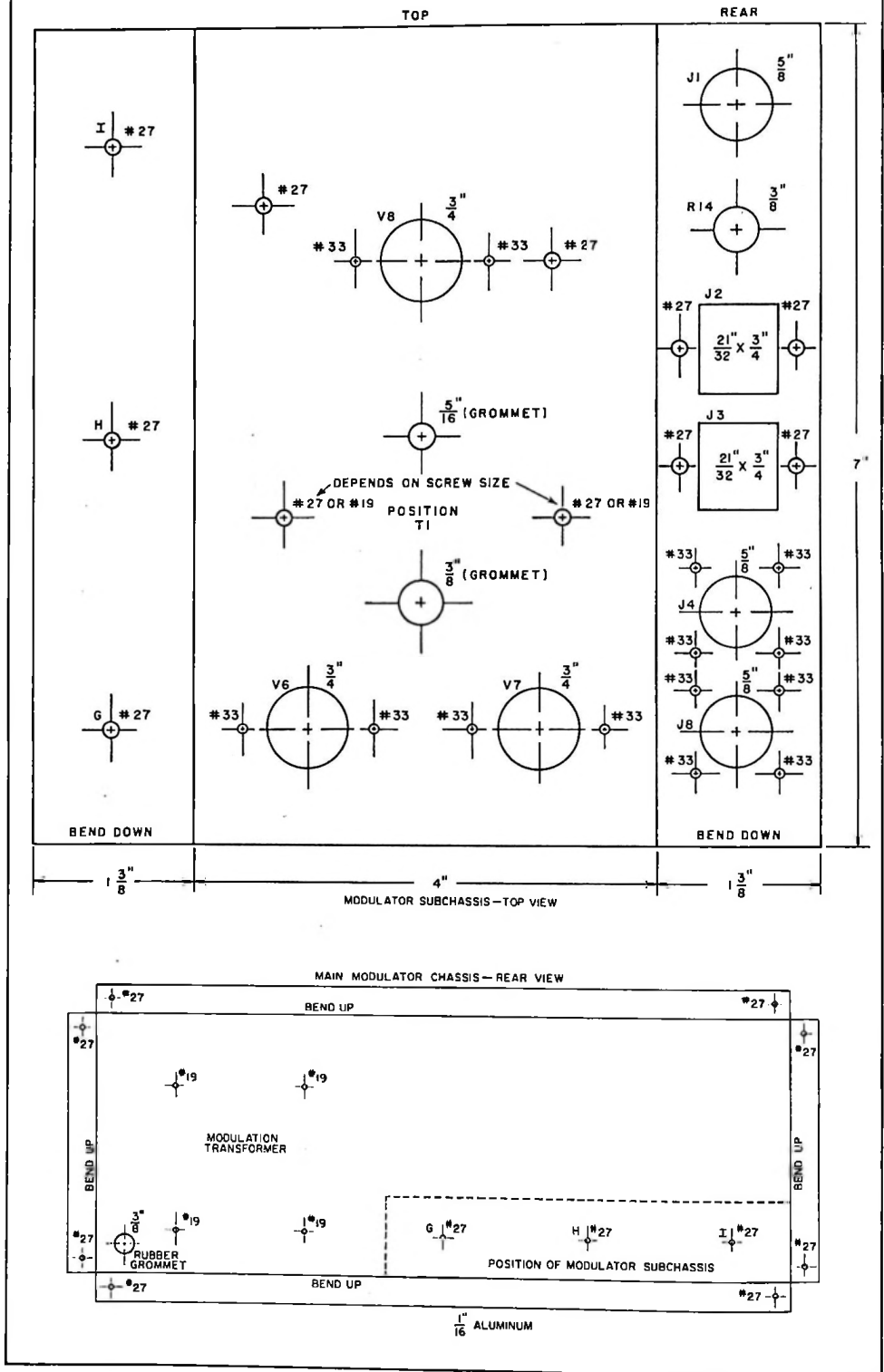

Figure 5: Construction details for modulator template (2 parts).

The alignment of the two-meter section of the transmitter is accomplished as follows:

1. Set the bandswitch to the two-meter position.
2. Set the VFO to 145.5 megacycles on the dial.
3. Peak capacitor C_7 for maximum output on the meter in position 1.
4. Peak capacitor C_{15} for maximum output with the meter in position 2.
5. Set capacitor C_{22} to its half-capacitance position.
6. Set capacitor C_{23} to half-capacitance (brass slug half out of the cylinder).
7. "Squeeze" coils L_4 and L_5 and adjust C_{23} to obtain maximum drive with the meter in position 3.
8. If there is no meter indication, adjust C_{32} until some drive is obtained, then return to step No. 7, above.
9. Set capacitor C_{33} to its half-capacitance point as in step No. 6.
10. Set C_{32} to its half-open position.
11. "Squeeze" coils L_6 and L_7 and adjust C_{33} for maximum output.
12. Adjust capacitor C_{18} (screen-grid neutralizing capacitor) for minimum change in drive as the plate tuning capacitor (C_{10}) is tuned back and forth through resonance.
13. Connect the 400-volt B+ supply; plug in the modulator tubes; and connect a dummy, non-inductive load to the two-meter antenna jack.
14. With the meter in position 4, turn on the transmitter and tune C_{10} for the resonance dip. Load the dummy load with C_{11} so the dip in plate current occurs at 150 milliamperes. This value should be the maximum plate cur-

rent used. Recheck grid drive to the final and readjust C_{32} if necessary.

15. As C_{10} is rocked through resonance, recheck the neutralizing capacitor C_{18} for minimum change in grid drive to the 4604. Meter should be in position 3.

16. Switch the meter to position 5 and check modulator current. Modulator should idle at approximately 55 milliamperes and peak up to 125 milliamperes with voice modulation.

17. The antenna link positioning should be adjusted if capacitor C_{41} does not pass sufficient power to the load. The output into a 50-ohm non-inductive load, with 1:1 SWR should be approximately 20 watts at 145 megacycles and 30 watts at 51 megacycles.

18. Turn off the transmitter. Switch to six meters. Turn on the transmitter and tune up on 51 megacycles. No change in neutralizing should be required on the 4604 final.

When tuning the transmitter on the two-meter band, set the VFO to the desired frequency, then tune C_7 , C_{15} , and C_{32} for maximum indication on the meter in respective positions 1, 2, and 3. With the meter in position 4, tune C_{10} for resonance and C_{41} for maximum power into the antenna.

As with any antenna fed from a transmitter link, the SWR should not be allowed to get too high (over 2:1) or it will be impossible to tune the transmitter properly. Link tuning is different from pi-net loading, which can usually couple appreciable power into a transmission line with a high SWR.

In all the above adjustments, it is necessary to have either a microphone in the carbon-mike socket or a switch in the proper J_1 termi-

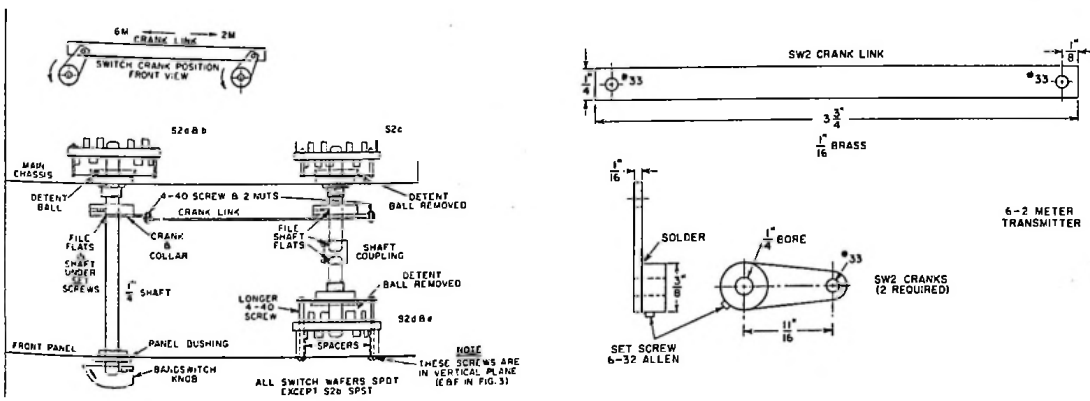

Figure 6: Detail of switches S_{2a} , S_{2b} , S_{2c} , S_{2d} , and S_{2e} (2 parts).

nals to turn the transmitter and quick-heating tube filaments on and off.

Conclusions and Installation Tips

The output section of this transmitter is designed to operate into a 50-ohm coaxial transmission line. Because of its small size, RG-58-U is ideal for mobile installation. A quarter-wave whip or combination coaxial antenna can be used with excellent results, although many amateurs today prefer horizontal polarization for mobile work. The coaxial relay switches the 50-ohm line from the antenna to either the receiver or transmitter and permits single-button, push-to-talk operation while the vehicle is in motion. As shown in Figure 2, pin No. 1 on P₃ is wired to energize a relay with heavier contacts which turns on the high-voltage power supply. Additional suggested power supply and antenna connections are shown in Figure 2.

The final amplifier could be operated with a combination of fixed negative bias and developed bias from drive. Under these conditions, the fixed bias would prevent the 4604 from exceeding rated plate dissipation in the event grid drive were lost. The fixed-bias feature is not incorporated in this transmitter because a negative supply was not available from the authors' dynamotor power supply.

Sufficient room is available on the front

panel for an additional switch and crystal socket. If this feature is added, a crystal-controlled oscillator may be used in place of the VFO, as mentioned earlier in this article. The oscillator can be a 7905 quick-heating tube which would result in zero-standby power for the rf section. A 10-ohm resistor would have to be used in series with the 6-volt 7905 filament for 12-volt operation. This low-drain feature, plus crystal control, should be ideal for six- or two-meter CD work where portable power is at a premium. If such a 7905 crystal oscillator is employed, fixed bias on the 4604 is mandatory to protect the tube during the time the oscillator comes on.

Lower standby power could be obtained by substitution of a transistorized modulator, however, the tube modulator is less costly because of the higher cost of comparable transistors. A dynamotor power supply would be less costly than a transistorized power supply, especially because of the availability of war-surplus units.

The individual constructor may wish to incorporate his own variations in design, depending on personal preferences. This article shows what can be done with the new line of quick-heating transmitting electron tubes in mobile work—tubes made by RCA which offer the "mobiler" more VHF output power per dollar than any present-day semiconductor device!

Information furnished by the Radio Corporation of America is believed to be accurate and reliable. However, no responsibility is assumed by RCA for its use; nor for any in-

fringements of patents or other rights of third parties which may result from its use. No license is granted by implication or otherwise under any patent or patent rights of RCA.



From your local
RCA distributor,
headquarters for
RCA receiving
and power tubes.

RCA HAM TIPS
is published by the
RCA Electron Tube
Division, Harrison,
N. J. It is available
free of charge from
RCA distributors.

WHEN MAILING
PLACE POSTAGE HERE

STATION WFDF RS
GARLAND AT FIRST AVE
FLINT 2 MICH

