



# HAM TIPS



A PUBLICATION OF RCA ELECTRONIC COMPONENTS AND DEVICES

VOL. 24, NO. 3

©1964, RADIO CORPORATION OF AMERICA

SUMMER, 1964

## A Low-Cost High-Efficiency Modulator

By R. K. Lockhart, K2HAK\*

RCA Defense Electronic Products

Recent design of a mobile transceiver by the author occasioned the need for a low-cost, high-efficiency modulator.

Since it was planned to have the transceiver operate directly from an auto battery, it was important that both the number of heaters and the amount of heat dissipated within the case be kept at absolute minimums.

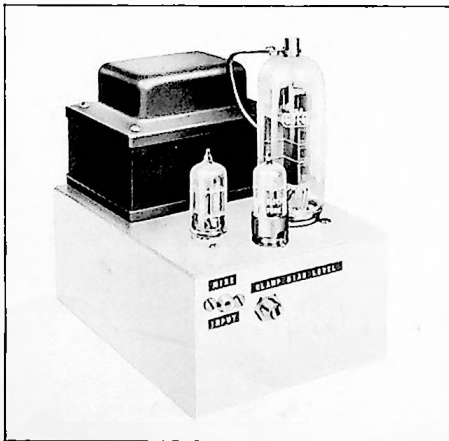

K2HAK's modulator employs TV-receiver type power transformer whose high-voltage secondary windings are designed to pass considerable current. Front of modulator shows "Mike Input" and slotted shaft for adjusting "Clamp Bias Level."

The prospect of employing *Heising* (constant-current) modulation was ruled out. This type of modulator does not possess the effectiveness deemed necessary in this instance, nor does it meet the requirement that the carrier be well filled. With an anticipated power of more than 50 watts, the all-important positive envelope peak would be heavily clipped if the audio tube were to be kept within plate dissipation rating. It was apparent also that the output transformer would become a problem as the DC currents of the audio stage and the RF amplifier would be in phase—saturating the core, and becoming additive in terms of IR drop in the transformer.

The answer seemed to lie either in the use of two tubes as a push-pull modulator or in utilization of screen modulation. The first choice, however, violated the filament and heat requirement, while its alternative did not offer the RF output of plate modulation. (Plate modulation provides nearly four times the peak-envelope power for a given carrier power.) Some deliberation on the subject yielded the circuit described in the text that follows. In this discussion, the over-all arrangement in its simplest form is treated first. Following this, the article describes two modifications, and the advantages of each.

### Principal Features

Figure 1 serves to highlight several main features of the circuit.

\*Manager, Advanced Digital Techniques, Applied Research Department, Camden, N. J.

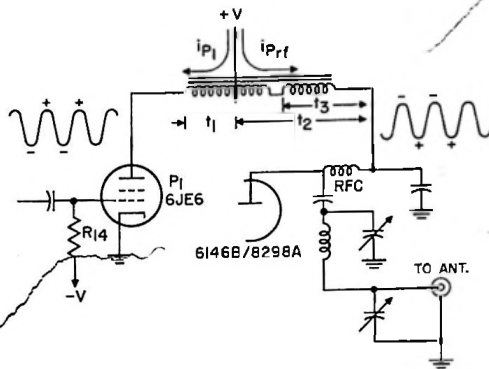

Figure 1: Autotransformer connections showing details of step-up configuration.

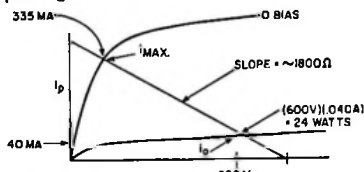

Figure 2: Modulator plate load characteristic.

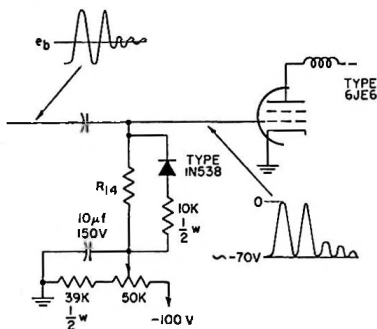

Figure 5: Insertion and operation of clamp diode.

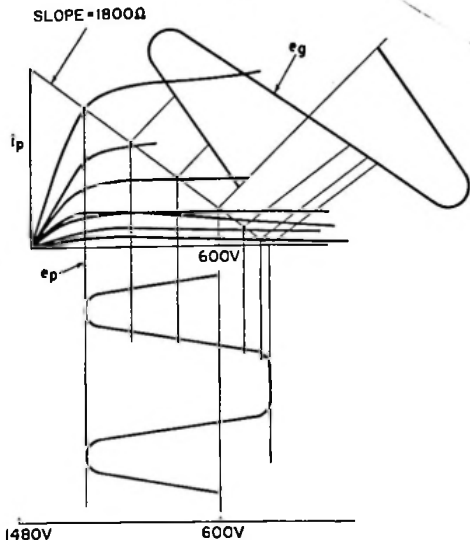

Figure 3: Modulator transfer characteristic.

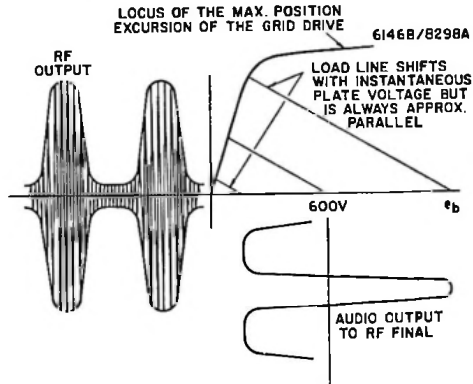

Figure 4: Representation of resulting plate modulation.

The DC plate current of the audio output tube flows in the opposite direction with respect to that of the RF amplifier in the modulation transformer. Consequently, the saturation components tend to buck each other in the core. Since the DC currents do not flow through a common winding, the IR drop of the modulator current does not subtract from the voltage supplied to the RF stage; and as the power loss in the transformer is proportional to  $I^2$ , this loss is also reduced.

Because the phase of the audio signal is inverted in going to the RF final, the side of the speech waveform suffering clipping is on the downward side, envelope-wise, and the peak of the envelope is undistorted. As this clipping is appreciable, the turns-ratio,  $t_2/t_1$ , can be increased to the point where the clipped downswing approaches zero-carrier and a degree of super-modulation may be achieved. In actual practice, the author has been able to measure modulation upswing as high as 140% while holding downswing to about 95%.

This method of clipping produces high-level speech-limiting which provides good weak-signal readability without splatter.

Because of the inherently high power sensitivity of the RCA-6JE6 novar-type beam-power tube (i.e.,  $g_m$  of about 12,000), a good plate modulator may be designed requiring only this tube and the RCA-12AX7A high-mu twin triode for full plate modulation of transmitters such as Heath's *Cheyenne*, or various rigs designed for novice use.

A TV-type power transformer designed for a full-wave rectifier should prove adequate. The author resurrected an old power transformer formerly used in a 7-inch TV set (RCA Model 621). This power transformer has the following characteristics:

- One winding for 117 volts (primary), which is not used
- One winding for 500 volts @ 0.250 ampere, RMS center-tapped
- Two filament windings (i.e., one for 6.3 volts @ 3.5 amperes, and one for 5.0 volts @ 3.0 amperes)

Television-receiver-type transformers are particularly well adapted to this use because their high-voltage secondary windings are designed to pass considerable current.

**Circuit Design**

In examining circuit design, let us assume that we are employing a *Cheyenne* transmitter which utilizes an RCA-6146B/8298A beam-power tube in the output and is designed for use with a 600-volt power supply. The manufacturer's rating allows 600 volts max. and 180 ma for class C plate modulation (6146B). Since the plate dissipation will be exceeded (under certain conditions) if both max. voltage and current are loaded into the tube simultaneously, we further assume a conservative rating of 600 volts and 150 ma for line-voltage changes. This represents a resistance of:

$$R = E/I \text{ or } 600/0.15 \text{ or } 4,000 \text{ ohms}$$

This resistance is reflected into the modula-

tor transformer. The turns-ratio of the modulation transformer can be expressed by the voltages of the respective windings. If the secondary is wound for about 250 volts rms, the turns-ratio is:

$$n = \frac{250 + 115}{250} = 1.46$$

The impedance ratio, of course, is the square of the turns-ratio (i.e.,  $[1.46]^2$  or 2.15). Since the autotransformer is connected "step-up," the reflected impedance on the audio output is:

$$Z = 4,000/2.15 \text{ or about } 1,800 \text{ ohms}$$

The next step is to draw the load line on the plate "family-of-curves" for the RCA-6JE6, as represented in the simplified sketch in Figure 2. The operating point is determined by the plate dissipation and the grid bias is adjusted until that point is met. The plate dissipation of the 6JE6 is listed at 24 watts—represented by 40 ma—for which current the bias is adjusted with no audio signal. The power output for the undistorted swing is calculated as follows:

Figure 6: Complete schematic diagram and parts list of K2HAK's low-cost, high-efficiency modulator.

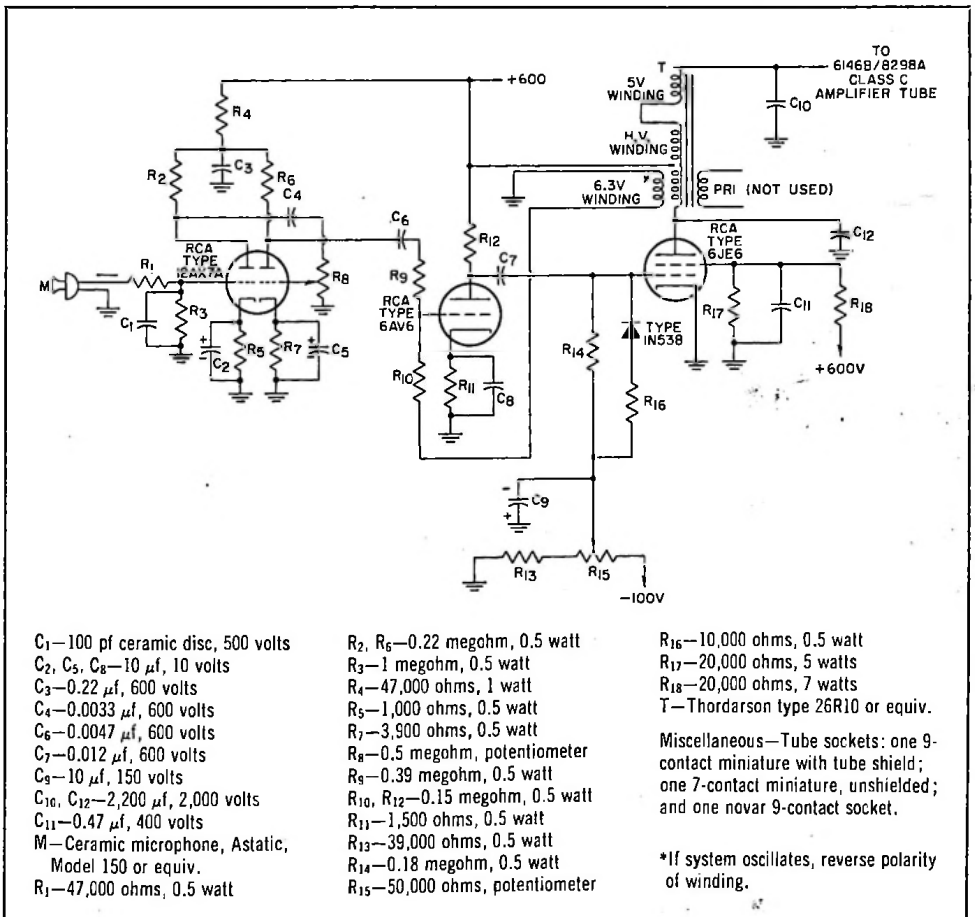

$$\hat{i} = (i - i_0) = 335 - 40 = 295 \text{ ma peak, or } 210 \text{ ma rms}$$

$$P_0 = (210)^2(1800) = 79 \text{ watts}$$

As the power input to the final is 600 volts multiplied by 0.15 ampere, the audio power required for 100% plate modulation is half that amount, or 45 watts. The actual modulation factor obtainable in the upward direction is the square root of the ratio of power available to that required for 100% or:

$$\sqrt{\frac{79}{45}} \text{ or } 139\%$$

Figure 3 shows how the distortion actually occurs. The bottom scale provides the instantaneous values after inversion occurs in the autotransformer. Figure 4 shows how this signal modulates the RF final.

The first version constructed by the author was intended for use in his own mobile rig. After this, a second unit was built incorporating the modifications described below.

#### Modifications

The following disadvantages of the original modulator indicate two areas of possible modification or improvement:

- Although the 24 watts represent a small percentage of the total power used by the modulator, this wattage is nevertheless a serious heat producer.
- The negative peak-clipping that permits

the high degree of modulation possesses inherent distortion.

The 24 watts may be reduced to as low as two watts by the insertion of a DC-setting type diode across  $R_{14}$  (see Figure 5). This allows the bias to be adjusted to produce zero plate current in the absence of audio, thus approaching true class B operation in the sense that the diode sets bias upward.

Insofar as the second disadvantage is concerned, eliminating inherent distortion is no simple matter. On the other hand, satisfactory quality can be obtained without loss of efficiency by adding another voltage amplifier and eliminating the extra gain by inverse feedback (see Figure 6). This second modification was incorporated in a model constructed by the author and compared for performance quality against the modulator (push-pull class B modulator with inverse feedback) incorporated in his regular transmitter. There was little observable difference. (Proper polarity of the feedback winding connection is necessary to maintain a negative value. Reversed polarity may cause the system to oscillate.)

The complete circuit schematic appears in Figure 6, together with the associated parts list. Through use of this modulation system, the discerning ham can go far toward achieving real economy and efficiency in practical modulators.

Information furnished by the Radio Corporation of America is believed to be accurate and reliable. However, no responsibility is assumed by RCA for its use; nor for any in-

fringements of patents or other rights of third parties which may result from its use. No license is granted by implication or otherwise under any patent or patent rights of RCA.



From your local  
RCA distributor,  
headquarters for  
RCA receiving  
and power tubes.

RCA HAM TIPS  
is published by RCA  
Electronic Components  
and Devices, Harrison,  
N. J. It is available  
free of charge from  
RCA distributors.

WHEN MAILING  
PLACE POSTAGE HERE

STATION WDFD  
GARLAND AT FIRST AVE  
FLINT 2 MICH RS

