

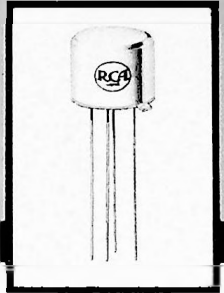

HAM TIPS



PUBLICATION OF RCA ELECTRONIC COMPONENTS AND DEVICES

VOL. 27, NO. 3

© 1967, RADIO CORPORATION OF AMERICA

OCTOBER, 1967

Using the MOS Field-Effect Transistor As a Product Detector and AGC Gate

By W. M. Stobbe, W3KDT*
RCA Electronic Components and Devices

The paragons of two worlds of electronics — the vacuum tube and the solid-state device — have been successfully combined in the RCA-developed insulated-gate metal-oxide-semiconductor (MOS) field-effect transistor. This transistor features such useful characteristics as extremely high input impedance, excellent low-noise qualities, high power gain throughout the VHF region, and a square-law transfer characteristic over a substantial current range. Its transfer characteristic makes the device ideal for use as a product detector. Considerably less BFO voltage (in the order of a few millivolts) is required in this transistor than in the conventional diode or other devices.

In the following article, W3KDT describes the use of the RCA-3N128 MOS field-effect transistor as a product detector and automatic-gain-control recovery gate in converting an older-type receiver to single-sideband use. The AGC system is unique in that it receives signal from the receiver noise-limiter output and therefore prevents noise peaks from initiating the AGC voltage.

It may be noted by some readers that, from a purely theoretical standpoint, this circuit is a departure from some conventional product-detector circuits. The end results of this single-sideband-detection system, however, are quite comparable.

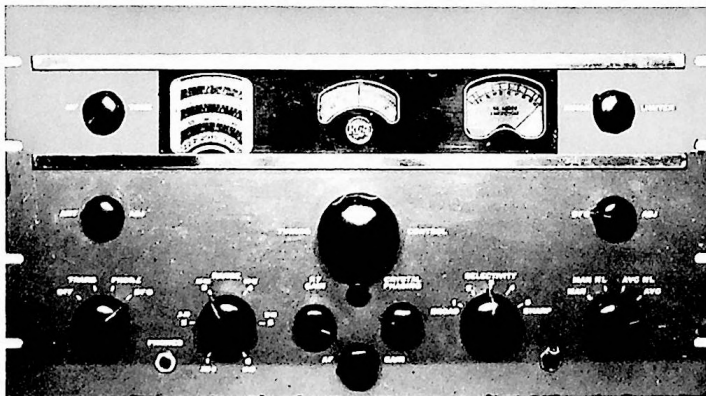

Figure 1: Front panel of the RCA-CR-91 general-purpose communications receiver. The AGC switch (extreme right) was subsequently modified to include "SSB" in a fifth position.

*Electronic Instruments Operations, Harrison, N. J.

Following the end of World War II, the RCA-CR-91 general-purpose communications receiver (see Figure 1) found its way into the hands of numerous hams through war-surplus channels.

The author has used a general-purpose receiver of this type for several years and—with the growing popularity of single side-band—began to investigate the various methods for adapting the unit to SSB operation.

This paper discusses the design of a product detector and AGC circuit that incorporates the MOS field-effect transistor as the active element. Figure 2 shows a block diagram of the SSB receiver, indicating the positions of the product detector and AGC circuits. These circuits are connected into the receiver for SSB operation by means of the automatic-volume-control (AVC) switch. *Although the product detector and AGC system are discussed with specific reference to the CR-91 receiver, these circuits may be applied to any general-purpose communications receiver. Separate schematics are illustrated in the text for this purpose.*

Product Detector

Figure 3 shows the schematic diagram of the product detector. A separate IF-transformer, T_{100} , is used to couple the SSB-IF-signal from the grid of the third IF-amplifier tube to the field-effect transistor. Capacitor

C_{101} minimizes capacitive loading on the circuit being sampled and also permits tuning of the primary winding of the transformer, T_{100} . Capacitor C_{102} , which consists of a twisted-wire "gimmick," couples the BFO voltage to the product detector. Any excess BFO voltage blocks the SSB signal and reduces the output level.

As the output of the product detector is switched into the receiver audio-frequency volume control, the output of the conventional AM detector is disconnected from the circuit. The BFO should be "on" and the AVC system switched to "manual." Gain is then controlled by the RF gain control. If the audio AGC is used, this voltage is connected into the receiver AVC bus. Audio volume is then set to about three-quarters of full "on," and the sensitivity is controlled by the RF gain control. The SSB signal is tuned for maximum intelligibility by means of the main tuning control and the BFO pitch control.

Audio AGC

Operation on SSB can be greatly enhanced by use of an audio-derived AGC circuit. This circuit permits controlled volume and use of the "S" meter to interpret signal strength.

The AGC circuit shown in Figure 4 consists of a two-stage audio amplifier that uses silicon n-p-n transistors; an AGC diode; and a MOS field-effect transistor for the recovery

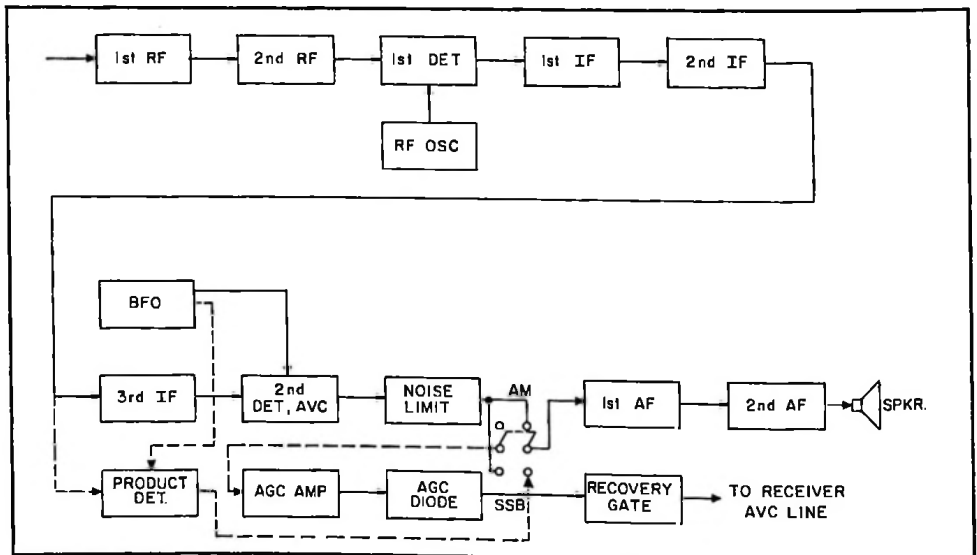

Figure 2: Block diagram of a typical general-purpose communications receiver showing additions (dashed lines) of product detector and AGC system.

gate. Proper operation of this circuit requires a completely isolated AVC line in the receiver with infinite resistance to ground, and use of the MOS transistor in conjunction with a time-constant circuit to control recovery to the maximum-gain bias condition.

The AGC-amplifier input signal is obtained from the output of the receiver noise limiter. This arrangement removes noise peaks which might initiate AGC. A good-quality audio-

amplifier section is not required at this point because the control voltage is developed by the peaks on the waveform of the average human voice.

After the signal is amplified, it is passed into the AGC diode, CR₂. The output of the diode is applied to the time-constant RC network, R₁₁ and C₆, which controls the decay time of the AGC. The MOS transistor is connected across the AGC output line, and is in a

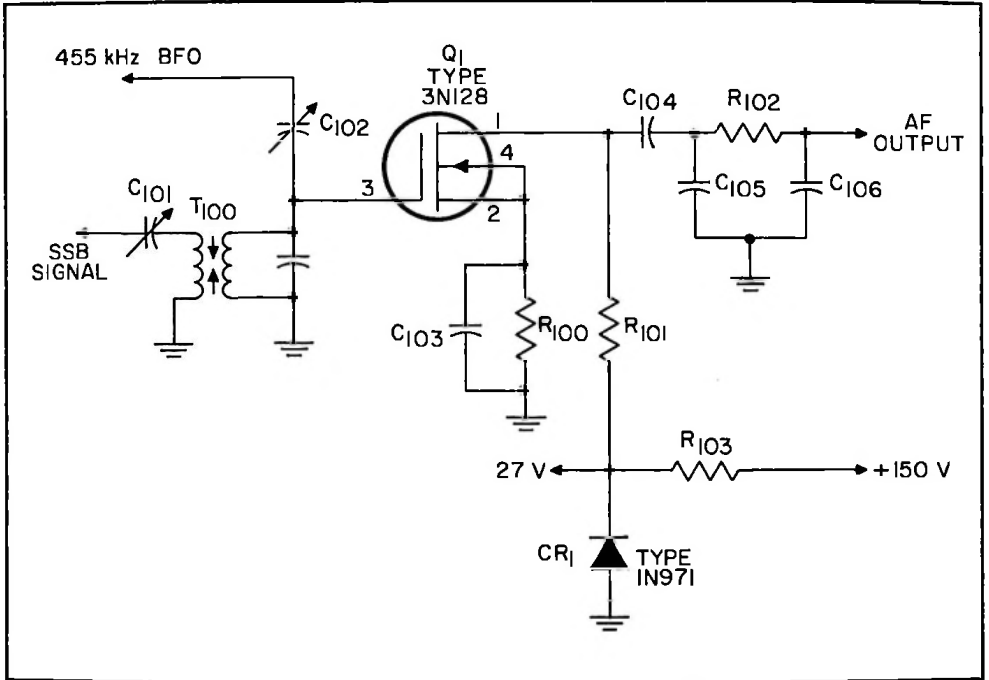

Figure 3: Schematic diagram of product detector.

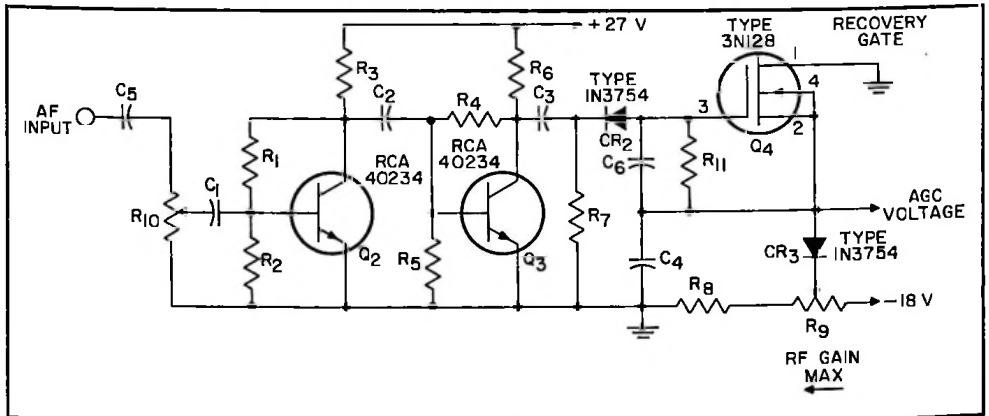
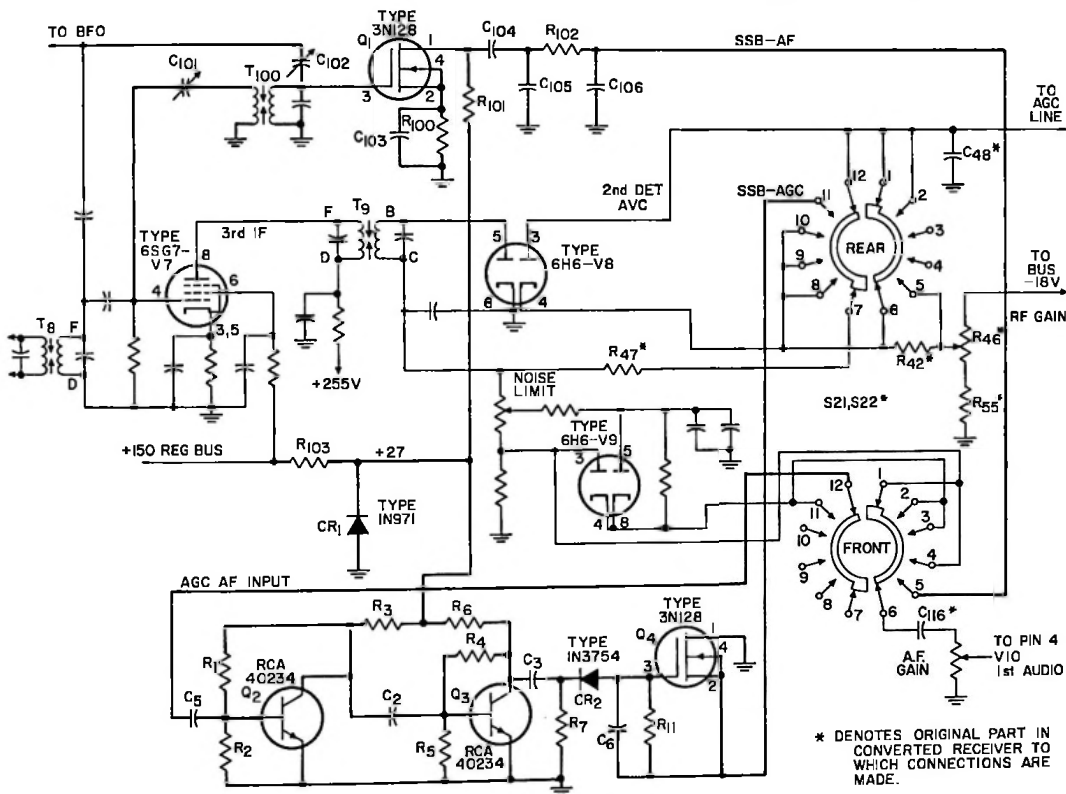

Figure 4: Schematic diagram of AGC system.

nonconducting state when the signal is applied. The threshold of conduction is determined by the receiver RF gain control. The RF gain control is isolated from the AGC line by means of the receiver AVC diode, CR₃. The time-constant RC network discharges at its normal rate until the gate voltage on the field-effect transistor reaches a point with re-

spect to the source that permits conduction to take place between the drain and the source. At this point, the AGC voltage decay is speeded up until another input signal resets the time constant. As a result, the AGC voltage has fast attack and slow decay to the point of conduction, and its "hang" time is determined by the values of R₁₁ and C₆. The



* DENOTES ORIGINAL PART IN CONVERTED RECEIVER TO WHICH CONNECTIONS ARE MADE.

Product Detector:

- C₁₀₁ — 4-40 pF, midget trimmer (Arco type 40-403 or equiv.)
- C₁₀₂ — 1 pF (twisted-wire "gimmick")
- C₁₀₃ — 0.47- μ F disc., 10-volt (Centralab UK-10 or equiv.)
- C₁₀₄ — 1,500-pF disc (Centralab DD-152 or equiv.)
- C₁₀₅, C₁₀₆ — 330-pF disc (Centralab DD-152 or equiv.)
- R₁₀₀ — 470,000 ohms, 1/2 watt
- R₁₀₁ — 1 megohm, 1/2 watt

- R₁₀₂ — 47,000 ohms, 1/2 watt
- R₁₀₃ — 15,000 ohms, 2 watts
- T₁₀₀ — IF transformer, 455 kHz (W. Miller 12-C1 or equiv.)

AGC Amplifier:

- C₁, C₂, C₃, C₅ — 0.01- μ F disc (Centralab DD-103 or equiv.)
- C₄ — 0.05- μ F disc, 20-volt (Centralab UK-20-503 or equiv.)
- C₆ — 0.47 μ F-disc, 10-volt (Centralab UK-10 or equiv.)

- R₁, R₄ — 33,000 ohms, 1/2 watt
- R₂, R₅ — 1,800 ohms, 1/2 watt
- R₃, R₆ — 10,000 ohms, 1/2 watt
- R₇ — 470,000 ohms, 1/2 watt
- R₈ — 5,600 ohms, 1/2 watt
- R₉ — 50,000 ohms, 2 watts, carbon potentiometer
- R₁₀ — 10,000 ohms, 1/2 watt, carbon potentiometer
- R₁₁ — 10 megohms, 1/2 watt
- S₂₁, S₂₂ — replacement, 5-position, 4-pole, 2-section wafer switch (Centralab PA-1012 or equiv.)

Figure 5: Schematic diagram of CR-91 receiver modified for SSB operation. Product detector and AGC system are indicated by heavy lines, with separate parts-list shown for each.

size of the capacitor, C_6 , may be varied to change the decay time as desired. A switch can also be used to select two or three different time constants.

For the components shown in Figure 4, the maximum-gain bias voltage is about -2 volts. There must be no leakage to ground on the AGC bus; even a resistance in the order of megohms will interfere with proper operation of the receiver. For example, the load of VTVM is sufficient to discharge the bus and destroy the "hang" feature. The minimum-gain AGC voltage levels off at about -7 volts as a result of saturation by the amplifying transistors. Additional limiting is obtained by adjustment of R_{10} .

AGC Operation

For optimum operation, the following parameters of the AGC system are adjusted:

- **Maximum-gain threshold.** The threshold voltage establishes the conducting state of the recovery gate, Q_4 , or the maximum-signal fixed-bias level set on the AGC line. This voltage is adjusted by means of the receiver RF gain control.

- **Minimum-gain limiting.** The amount of AGC bias voltage connected to Q_2 , Q_3 , and CR_2 depends on the amount of signal voltage present at the base of Q_2 . This voltage is adjusted by means of R_{10} .

- **"Hang" time constant.** This parameter is defined as the period of time from the initial signal that produces the AGC voltage until the discharge of the RC network to the point where Q_4 starts to conduct. This time may be varied by selection of different values of C_6 .

Modified CR-91 Receiver

Figure 5 shows the complete schematic for conversion of the CR-91 to SSB operation.

When the AGC circuit shown in Figure 4 is inserted in the CR-91 receiver for SSB operation, the maximum-gain bias voltage is

Figure 6: Layout of product-detector (left) and audio-AGC (right) components on vector board. Short wire in center of board is the product-detector output; long wire is the audio input for the AGC system.

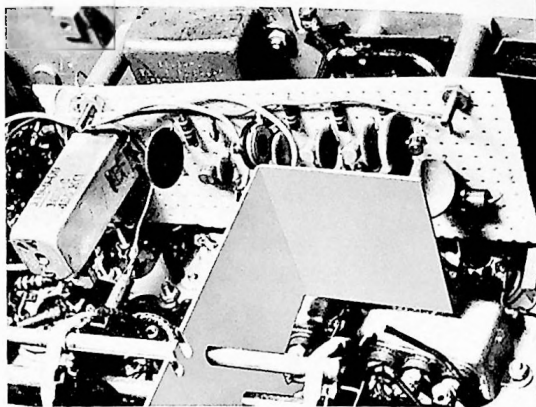

Figure 7: Mounting of circuit board under the receiver chassis.

about -2 volts. Resistors R_8 and R_9 and Capacitor C_1 are replaced by R_{35} , R_{16} , and C_{16} , respectively, of the original receiver. The AVC diode, CR_3 , is replaced by one-half of the 6H6-V₈ diode tube, which is normally used in the AVC circuit. Minimum-gain limiting is accomplished by adjustment of the noise-limiter control. An increase of the noise-limiter action limits the available average audio input to the AGC amplifier. Because only one value of time constant is used, it is not necessary to add any controls or switches to the front panel.

The AVC switch (S_{21} , S_{22}) is replaced by a 5-position, 4-pole, 2-section wafer switch (Centralab PA-1012 or equivalent). The fifth position of this switch connects the receiver for SSB operation. Switching for SSB includes the following steps:

1. The AM detector output is disconnected.
2. The product-detector output is connected into the first audio stage.
3. The noise-limiter output is switched into the AGC amplifier.
4. The AGC output is switched into the AVC bus.
5. R_{17} (a 2-megohm resistor) is disconnected from the AVC bus.
6. R_{12} (a 390,000-ohm resistor) is shorted out, and V_8 is connected in series with the RF gain bias line as an isolation diode.

For SSB operation, the operator must also switch on the BFO. This function can be made part of the AVC switch by addition of another wafer with parallel connections to the BFO switch.

RCA HAM TIPS is published by RCA Electronic Components and Devices, Harrison, N. J. It is available free of charge from participating RCA Industrial Distributors. It is also available on a two-year subscription basis (\$1 for eight issues to cover costs of handling and mailing). Please make check or money order payable to Radio Corporation of America, and remit to "Radio Corporation of America, Section 882, Harrison, N. J. 07029."

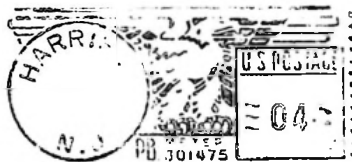
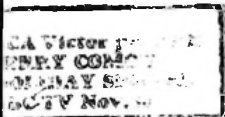

RS
STATION WFDF
WFDF FLINT CORP
406 GARLAND ST
FLINT MI 48503

Information furnished by the Radio Corporation of America is believed to be accurate and reliable. However, no responsibility is assumed by RCA for its use; nor for any in-

fringements of patents or other rights of third parties which may result from its use. No license is granted by implication or otherwise under any patent or patent rights of RCA.

Power for both the product detector and the AGC amplifier is obtained from the regulated 150-volt bus. This voltage is reduced to 27 volts by means of a dropping resistor and a zener diode.

Construction

Except for controls and switches, the entire circuit is mounted and wired on a vector board, approximately $6\frac{3}{4}$ inches long and $2\frac{3}{4}$ inches wide, as shown in Figure 6. Figure 7 shows how the board is fastened at a convenient place under the receiver chassis by use of long bolts and spacers. Wires are then run from terminals on the board to the receiver circuits.

Alignment of Product Detector

For alignment of the product detector, a tone-modulated RF signal is applied to the receiver antenna terminals or a local AM signal is tuned in. The function switch is set for AM reception, and the BFO is switched off. An oscilloscope is connected to the output of the product detector. Capacitor C_{101} is set to about half range, and the secondary winding of the 455-kHz IF transformer, T_{100} , is adjusted for maximum audio output as indicated on the 'scope. The T_{100} primary is then adjusted for maximum output. If the primary does not peak, capacitor C_{101} is readjusted (starting with minimum capacitance) until peaking occurs. The receiver 455-kHz IF transformer is then readjusted for maximum

output to compensate for the loading effect, and all previous adjustments are repeated.

With the BFO on, the receiver is switched for SSB reception. An SSB signal is tuned in, and the BFO is adjusted for normal intelligence. Capacitor C_{102} is then adjusted for maximum audio output. An excess BFO voltage reduces the output. In the CR-91, the BFO is coupled to the product detector through two capacitors. The capacitance between the tube pins of the 6J5 BFO octal socket, plus the capacitance provided by the additional twisted-wire "gimmick" in series, should yield the approximate amount of coupling required.

Conclusion

Successful results have been achieved by the author in converting both the RCA-CR-91 and the RCA-AR-88D general-purpose communications receivers to single-sideband operation. The CR-91 is similar to the AR-88 except that it has two low-frequency bands and a 735-kHz IF. T_{100} was modified to tune to this frequency by removing approximately 60 turns from the primary and secondary.

Strict attention to details of construction, and careful observance of RCA instructions in the handling of MOS-FET's, should provide the builder with an important additional function for his receiver at a moderate cost.

Reference: Barnes, S. H., and Luettgenau, G. G., "Designing with Low-Noise MOS FET's: A Little Different but no Harder," ELECTRONICS, December 14, 1964, page 53.