

ham tips

November 1969 | Volume 29 Number 2

A Precision Three-Mode Voltage Calibrator

By D. W. Nelson, WB2EGZ
RCA Defense Electronic Products*

Do you remember the last time you calibrated your VTVM? You don't? Well, you probably can recall the date you needed to know the deflection sensitivity of your 'scope.

You can easily determine the sensitivity of your equipment and improve its accuracy with the aid of the three-mode voltage calibrator described by WB2EGZ in this issue. As an added bonus to building this useful instrument, you will gain a practical working knowledge of RCA's popular-priced CA3018 and CA3047A integrated circuits, as well as many valuable pointers on the versatile metal-oxide-semiconductor (MOS) field-effect transistor.

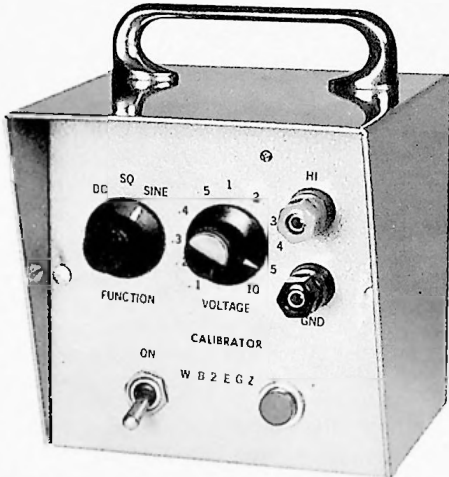

Figure 1: Exterior view of three-mode voltage calibrator constructed by WB2EGZ. A rather sophisticated circuit has been compressed into a 5-by-5-by-5-inch "cowl box."

Using the least complex circuit possible, the author has developed a voltage calibrator offering a choice of three outputs: DC, an RMS sine wave, and a peak-to-peak square wave. Unlike some other calibrators, no manipulation or guesswork is involved in using the AC (RMS) mode of this calibrator.

Circuit Description

The calibrator is best described in terms of the block diagram shown in Figure 2 and the schematic diagram shown in Figure 3. Two 1-kHz oscillators (a sine wave and a square wave) and a DC level form the basic generators of the correct waveforms. Any of the three modes may be selected and fed to a follower amplifier which prevents loading of the generators. The precision of the instrument is established at the output of the follower by a voltage divider. This is the only place in the circuit where precision parts are used. If an AC output were not

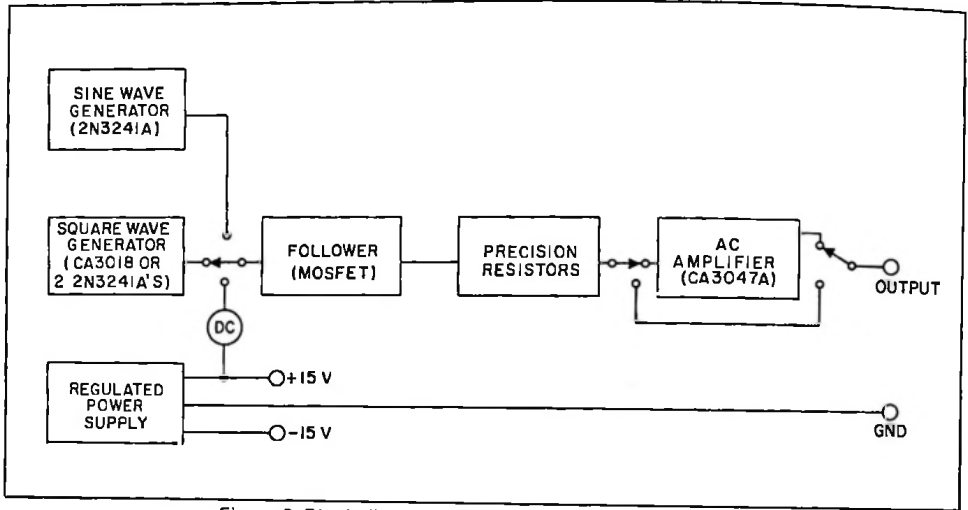

Figure 2: Block diagram of three-mode voltage calibrator.

needed, the circuit could terminate here.

The requirement for an alternating-current sine wave complicates the design appreciably because the basic generators cannot provide an undistorted wave form of sufficient amplitude. Remember that the peak-to-peak amplitude of a sine wave is 2.83 times the RMS value. Furthermore, the signal must average zero volts to make most voltmeters read correctly. These requirements have been met by using an operational amplifier of fixed gain in the AC section of the calibrator.

The three-mode calibrator requires regulated power supplies to maintain stability. The dual supply used with the calibrator is shown in Figure 4. A positive 15 volts powers the generators and the follower, but the AC amplifier uses a negative 15-volt supply as well. The 30-volt total permits generation of a 28.3-volt peak-to-peak undistorted output for the 10-volt RMS level. The use of positive and negative supplies permits the centering of the amplifier output around zero.

Two types of integrated circuits, or "IC's," are employed in the calibrator. One—the RCA-CA3018—contains four transistors, only two of which are used. The second IC—the RCA-CA3047A—is a direct-coupled amplifier that contains both resistors and transistors. The original intent was to combine the square-wave generator with the sine-wave generator by using all the transistors in the CA3018. Due to certain temperature problems, however, it was im-

possible to maintain accuracy in the AC mode with this configuration. Hence, the sine-wave oscillator was redesigned to use a discrete transistor, type 2N3241A. Two of this same type transistor may be used in the square-wave generator, if desired, without adversely affecting calibrator performance. The method of connecting the discrete transistors in place of the CA3018 is shown in Figure 5. In the instance of the AC amplifier, however, any substitution is out of the question. The CA3047A seems "made to order" for this application, and combines 21 transistors and 14 resistors in a very sophisticated circuit. Can you imagine the size of this circuit if tubes—or even transistors—were used?

Thermal stability presented the greatest design problem in this project. Power-supply voltage was stabilized by using 1N5216 silicon diodes in series with the 1N965 regulator diodes. Second, the sine-wave oscillator, which utilizes a twin-T bridge circuit, was stabilized by using two more 1N5216's in the base-biasing network. The system used in the sine-wave oscillator could be improved. In its present form, it limits the thermal drift to 2 percent of the output voltage. Long-term stability would be better if the diodes and transistor were physically connected as they are in an IC. Nearly perfect stability is the boast of the CA3047A operational amplifier. There is a slight long-term drift in the source-follower MOS transistor circuit, but this is insignificant for most amateur applications of the

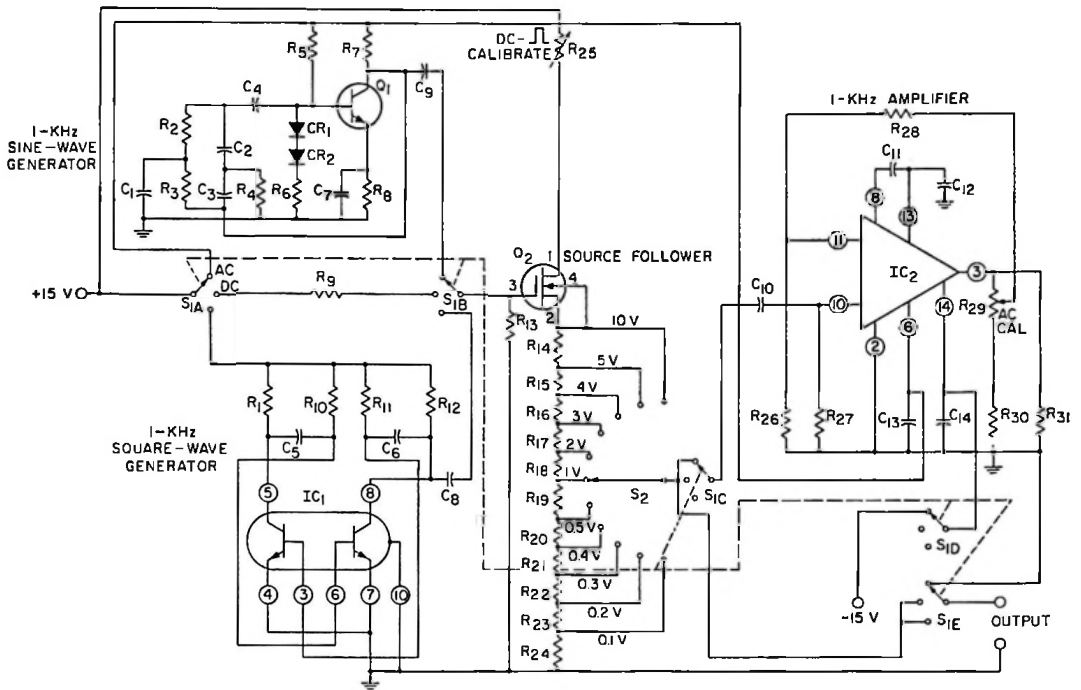

- C₁, C₂, C₃, C₄, C₁₂, C₁₀₃, C₁₀₄ — 0.01 microfarad, 50 volts, paper or ceramic tubular
- C₅, C₆ — 0.022 microfarad, 50 volts, paper or ceramic tubular
- C₇ — 2.2 microfarads, 6 volts, electrolytic
- C₈, C₉ — 0.047 microfarad, 50 volts, paper or ceramic tubular
- C₁₀, C₁₁, C₁₃, C₁₄ — 0.1 microfarad, 50 volts, paper or ceramic tubular
- C₁₀₁, C₁₀₂ — 1,000 microfarads, 50 volts, electrolytic
- CR₁, CR₂, CR₁₀₁, CR₁₀₂, CR₁₀₃, CR₁₀₄, CR₁₀₇, CR₁₀₈ — RCA-1N5216 silicon diode
- CR₁₀₅, CR₁₀₆ — 1N965 regulator diode
- F₁ — 1-ampere 3AG fuse
- I₁ — NE51 Neon indicator bulb
- IC₁ — RCA-CA3018 linear integrated circuit or two RCA-2N3241A silicon NPN transistors
- IC₂ — RCA-CA3047A linear integrated circuit
- Q₁, Q₁₀₁, Q₁₀₂ — RCA-2N3241A silicon NPN transistor
- Q₂ — RCA-3N128 or RCA-40467A or RCA-40468A single-gate MOS field-effect transistor

- Q₁₀₃, Q₁₀₄ — RCA-2N2613 germanium PNP transistor
- Q₁₀₅ — RCA-2N3053 silicon NPN transistor
- Q₁₀₆ — RCA-2N4037 silicon PNP transistor
- R₁, R₁₂ — 1.8 kilohms, ¼ watt, carbon
- R₂, R₃ — 27 kilohms, ¼ watt, carbon
- R₄, R₁₀₂, R₁₀₃ — 2.7 kilohms, ¼ watt, carbon
- R₅, R₂₆, R₂₇ — 100 kilohms, ¼ watt, carbon
- R₆ — 10 kilohms, ¼ watt, carbon
- R₇ — 4.7 kilohms, ¼ watt, carbon
- R₈ — 560 ohms
- R₉ — 820 kilohms, ¼ watt, carbon (may be adjusted for precise agreement between DC and square wave)
- R₁₀, R₁₁ — 39 kilohms, ¼ watt, carbon
- R₁₃ — 1 megohm, ¼ watt, carbon
- R₁₄ — 2 kilohms, ¼ watt, 1% deposited carbon or metal film
- R₁₅, R₁₆, R₁₇, R₁₈ — 400 ohms, ¼ watt, 1% deposited carbon or metal film

- R₁₉ — 200 ohms, ¼ watt, 1% deposited carbon or metal film
- R₂₀, R₂₁, R₂₃, R₂₄ — 40 ohms, ¼ watt, 1% deposited carbon or metal film
- R₂₅, R₂₉ — 1 kilohm miniature pot (Mallory MTC-L1 or equiv.)
- R₂₈ — 330 kilohms, ¼ watt, carbon
- R₃₀ — 1.5 kilohms, ¼ watt, carbon
- R₃₁ — 100 ohms, ½ watt, carbon
- R₁₀₁ — 120 kilohms, ½ watt, carbon (not necessary with 120-volt indicator assemblies)
- R₁₀₄, R₁₀₅ — 2.2 kilohms, ¼ watt, carbon
- R₁₀₆, R₁₀₇ — 1.5 kilohms, ½ watt, carbon
- S₁ — 5-pole, 3-position rotary (Centralab PA-2015 or equiv.)
- S₂ — 1-pole, 11-position rotary (Centralab PA-2000 or equiv.)
- S₁₀₁ — SPST toggle
- T₁₀₁ — power transformer (Triad F91X or equiv.)
- Miscellaneous — Cowl box (Bud SC-2133 or equiv.); heat sink (Thermalloy 2225-B or equiv.); binding posts; and 3AG fuse holder.

Figure 3: Schematic diagram and parts list of WB2EGZ calibrator.

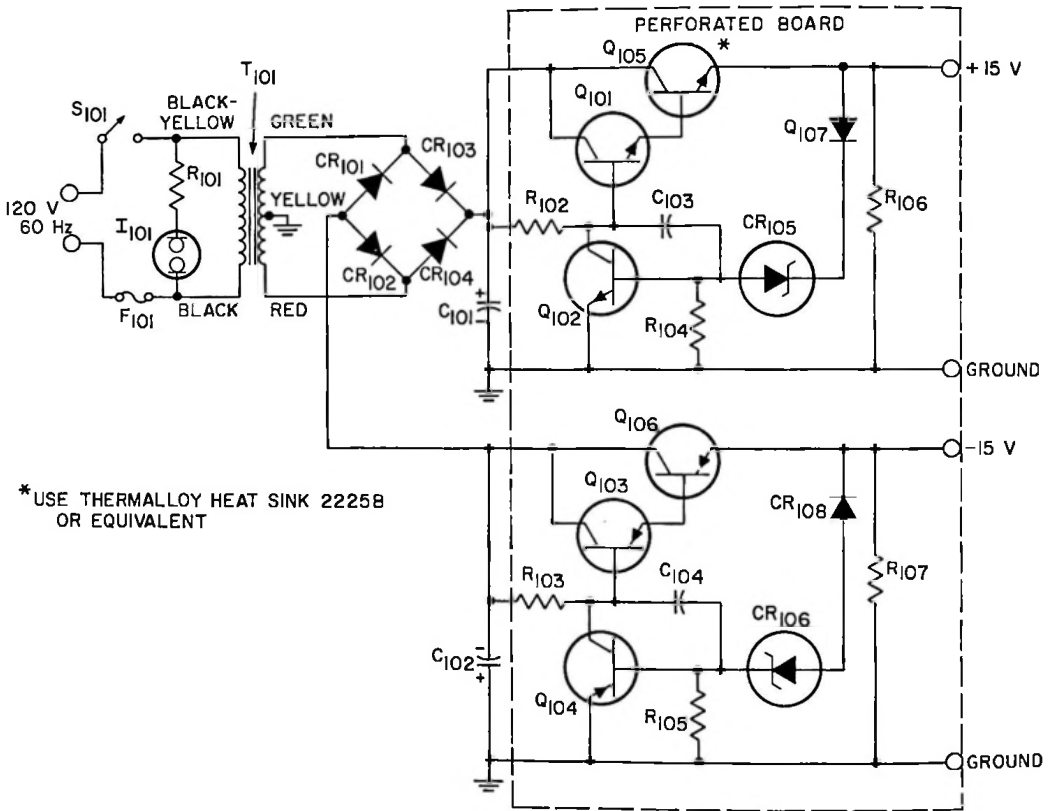

Figure 4: Schematic diagram of ± 15 -volt power supply.

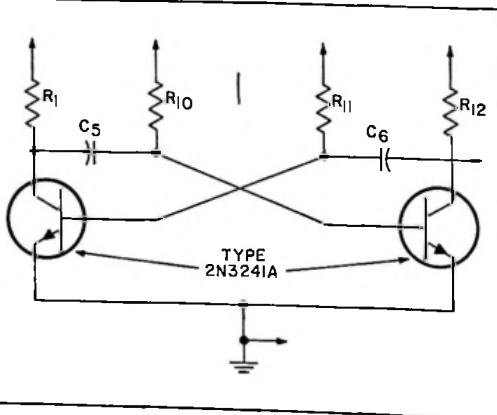
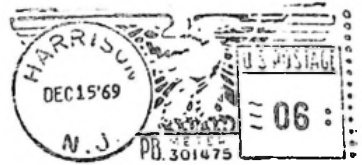

Figure 5: Schematic diagram of square-wave generator as it would appear if constructed with transistors in place of the CA3018 integrated circuit.

calibrator. No special compensation was added to the follower or square-wave generator portions of the calibrator.

Construction

Construction of the calibrator in a Bud "cow box" 5 inches square keeps its size to a minimum (see Figures 6, 7, and 8). In some instances, however, builders may prefer larger cases, particularly if the small ceramic capacitors suggested here are not available. Larger components are acceptable and their placement is not critical, provided that signal leads from the 60-Hz AC field are adequately shielded. In the calibrator described here, all such leads carrying calibration signal information have been shielded and the shields connected at a common point near the CA3047 (see Figure 8). This arrangement follows standard de-



HAM TIPS is published by the Electronic Components operation of RCA, Harrison, New Jersey. It is available from participating RCA Industrial Distributors or by writing to: RCA — HAM TIPS, 16-3, Harrison, New Jersey 07029.

RS
STATION WFDF
WFDF FLINT CORP
406 GARLAND ST
FLINT MI 48903

Information furnished by RCA is believed to be accurate and reliable. However, no responsibility is assumed by RCA for its use; nor for any infringements of patents or other rights

of third parties which may result from its use. No license is granted by implication or otherwise under any patent or patent rights of RCA.

be reduced by increasing the resistance of R_8 . Although not experienced by the author, it is possible that some CA3047A's will exhibit clipping in the output stage when driven to 28.3 volts peak-to-peak. The simple correction for this problem is to increase the 15-volt supplies to 16 volts by substituting 1N966's for the 1N965's now used. Once the output distortion is eliminated, R_8 may be readjusted for 28.3 volts peak-to-peak.

Your new three-mode voltage calibrator stands ready for use with the 'scope or VTVM. It's a rather sophisticated addition to the ham shack, isn't it? Remember that this design is not intended to check VOM's or panel meters. Although the error on a 20,000-ohm/volt meter is negligible, the error on a 1,000-ohm/volt DC meter will be 10 percent. Higher percentages of error can be expected on less sensitive meters.

Figure 9: Calibrator chassis layout.

DRILL SIZES

- A = No. 33
- B = No. 28
- C = No. 19
- D = 5/16
- E = 3/8
- F = 1/2

ALL DIMENSIONS IN INCHES.

