

A-450 ELECTRICAL CHECKS AND ADJUSTMENTS

0 dB = 0.775 V

| STEP NO. | ITEM | SWITCH/CONTROL SETTING | | | | | | INPUT SOURCE SIGNAL | OTHER CONDITIONS OR OPERATION | ADJUSTMENT ON DECK | SPECIFICATION | REMARKS | |
|---|---|------------------------|---------|----------|---------------|--------|----------|--|--|--|----------------------------|---|--|
| | | CONV. DIAG. | BIAS EQ | DOLBY NR | DOLBY FM/COPY | SOURCE | CONTROLS | | | | | | |
| I. PLAYBACK PERFORMANCE | | | | | | | | | | | | | |
| Test tape: MTT-150: For Dolby Level Calibration MTT-116K: For Frequency response test for EQ 1 & 2 MTT-116U: For Frequency response test for EQ 3 | | | | | | | | | | | | | |
| 1-1 | R/P Head Azimuth Adjustments | 1 | A | 3 | OUT | OUT | — | OUTPUT: Set as necessary for usable output level. | MTT-150 | Ensure phase relationship between L-ch & R-ch. | Azimuth adjustment of head | Phase 45° on oscilloscope | Phase relationship check |
| | | 2 | | | | | | | MTT-116U, 10 kHz section | | | Maximum | |
| 1-2 | Specified Output Level Setting | 1 | B | | | | | OUTPUT: Maximum | MTT-150 | — | VR102/202 | 100 mV (-18 dB) at Dolby T.P. | Maximum output Level |
| | | 2 | | ↓ | ↓ | ↓ | | OUTPUT: Set to get specified OUTPUT indicated in specification column. | | | | -3.5 dB ± 1 dB (461 mV ~ 580 mV) | |
| | | 3 | C | | | | | | | | | -5 dB (435 mV) | Specified Output Level |
| 1-3 | VU Meter Calibration - Playback - | | ↓ | ↓ | ↓ | ↓ | | OUTPUT: Specified setting | MTT-150 | — | VR107/207 | +3 VU (□□) on VU meter | After calibrating, ensure VU meter indication is same, when DOLBY NR switch is set to IN. |
| 1-4 | Frequency Response - Playback - | 1 | ↓ | | ↓ | ↓ | | ↓ | MTT-116U, 40 Hz ~ 14 kHz section | — | VR101/201 | See Frequency Response Limits on page 18 in the manual. | VR101/201 are only for high frequency spectrum adjustment. For Hi-Fi tape. |
| | | 2 | | 1 & 2 | ↓ | ↓ | | ↓ | MTT-116K, 40 Hz ~ 14 kHz section | — | | | For CrO ₂ & Fe-Cr tapes. |
| 1-5 | Signal to Noise Ratio Checks - Playback - | | ↓ | 3 | ↓ | ↓ | FM | ↓ | MTT-150 | PLAY-PAUSE mode | — | -52 dB min., or 1.94 mV max. (Corresponds to S/N ratio of 47 dB min.) | Measure OUTPUT level of noise signal and compare this to standard OUTPUT level of -5 dB. |
| 1-6 | Headphone Output Level Checks | | D | ↓ | ↓ | ↓ | | ↓ | MTT-150 | — | — | -21 dB ± 2 dB (54.8 mV ~ 86 mV) | Load imp.: 8 ohm |
| II. MONITOR PERFORMANCE | | | | | | | | | | | | | |
| Test tape: Any recordable tape RECORD-PAUSE mode NOTE: * means see REMARKS column. | | | | | | | | | | | | | |
| 2-1 | Minimum Input Level Checks | 1 | | | | | | OUTPUT: Specified Setting | 400 Hz/-67 dB ± 2 dB (274 μV ~ 435 μV) | Check by applying test signal to MIC jacks. | — | | For MIC jacks |
| | | 2 | E | | OUT | OUT | NORMAL | LINE: Minimum | 400 Hz/-35 dB ± 2 dB (10.9 mV ~ 17.3 mV) | Check by applying test signal to input terminals of DIN Connector. | — | 100 mV (-18 dB) at Dolby T.P. | For DIN connector |
| | | 3 | | | | | | OUTPUT: Specified Setting | 400 Hz/-15 dB ± 2 dB (109 mV ~ 173 mV) | Check by applying test signal to LINE IN jacks. | — | | For LINE IN jacks |
| | | | | | | | | LINE: Maximum | | | | | |
| | | | | | | | | MIC: Minimum | | | | | |
| 2-2 | Specified LINE Control Setting | | E* | | ↓ | ↓ | | OUTPUT: Specified Setting | 400 Hz/-5 dB (435 mV) | Set LINE controls for specification. | — | 100 mV (-18 dB) at Dolby T.P. | * Use LINE IN jack • Input level of -5 dB: Specified Input Level for LINE |
| | | | | | | | | LINE: Set controls to get specified OUTPUT | | | | | |
| | | | | | | | | MIC: Minimum | | | | | |
| 2-3 | DOLBY FM/COPY CAL Control Setting | | E | | IN | ↓ | | OUTPUT: Specified Setting | 400 Hz/-14 dB (154 mV) | — | DOLBY FM COPY-CAL controls | 100 mV (-18 dB) at Dolby T.P. | • LINE & MIC control setting do not affect level. • Input level of -14 dB: Specified Input level for DOLBY FM/COPY |
| | | | | | | | | LINE: Specified Setting | | | | | |
| | | | | | | | | MIC: Minimum | | | | | |
| 2-4 | VU Meter Calibration - Record - | | F | | OUT | ↓ | | ↓ | 400 Hz/-5 dB (435 mV) | — | VR106/206 | +3VU (□□) on VU meter | |
| 2-5 | LED Peak Level Indicator Calibration | | F | | ↓ | ↓ | | ↓ | 400 Hz/-2 dB (615 mV) & 400 Hz/-4 dB (488 mV) | — | VR108/208 | PEAK Indicator Lights at full intensity when input is -2 dB and goes off completely when input is -4 dB | |
| 2-6 | Dolby NR Effect Measurement | 1 | | | IN | ↓ | | 1 kHz | Set as necessary for specified output level | Adjust Attenuator for specification. | — | 10 mV (-38 dB) at Dolby T.P. | * Use LINE IN jack • LINE & MIC control setting is ineffective. • 10 mV of specification is reference level for next step. |
| | | 2 | E* | | IN | ↓ | | ↓ | | Ensure VTVM reading reduces to specification from reference level when Dolby NR switch is switched from OUT to IN. | — | (Variation at 1 kHz) 5 dB ± 1 dB | |
| | | 3 | | | OUT | ↓ | | 10 kHz | Set as necessary for specified output level | Adjust Attenuator for specification. | — | 3.2 mV (-48 dB) at Dolby T.P. | • 3.2 mV of specification is reference level for next test. |
| | | 4 | | | IN | ↓ | | ↓ | | Ensure VTVM reading reduces to specification from reference level. | — | Variation at 10 kHz: 10 dB ± 1 dB | |
| 2-7 | Dolby FM Compensator Efficiency Checks | 1 | | | OUT | ↓ | FM | 400 Hz/-14 dB (154 mV) | Note VTVM reading for reference level for next test. | — | — | — | — |
| | | 2 | | | ↓ | ↓ | | 10 kHz/-14 dB | Ensure VTVM reading raises to specification from reference level when input signal frequency is changed. | — | — | Variation with SOURCE at FM position: 8 dB ± 1 dB | LINE & MIC control setting is ineffective. |
| | | 3 | F | | ↓ | ↓ | NOR. | 400 Hz/-14 dB | Note VTVM reading for reference level for next test. | — | — | — | — |
| | | 4 | | | ↓ | ↓ | | 10 kHz/-14 dB | Ensure VTVM reading differs within specification from reference level. | — | — | Variation with SOURCE switch set to NORMAL: (0 dB ± 1 dB) | — |

CONNECTIONS

A

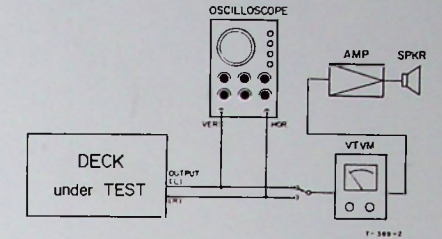

B

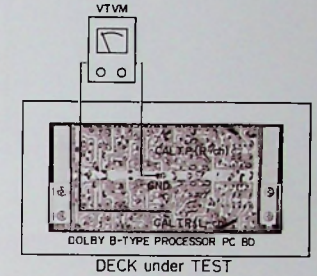

C

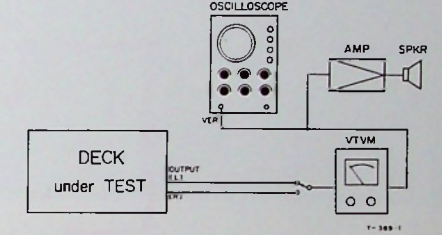

D

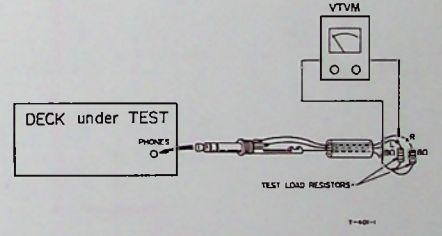

E

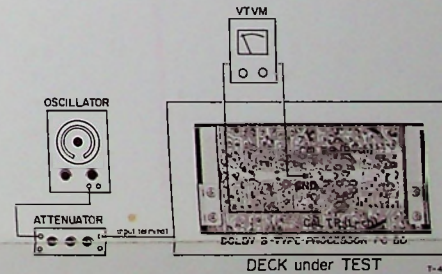

F

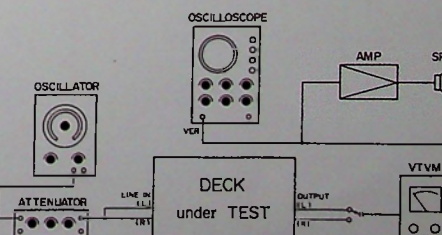

G

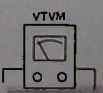

SIMPLIFIED CIRCUIT DIAGRAM

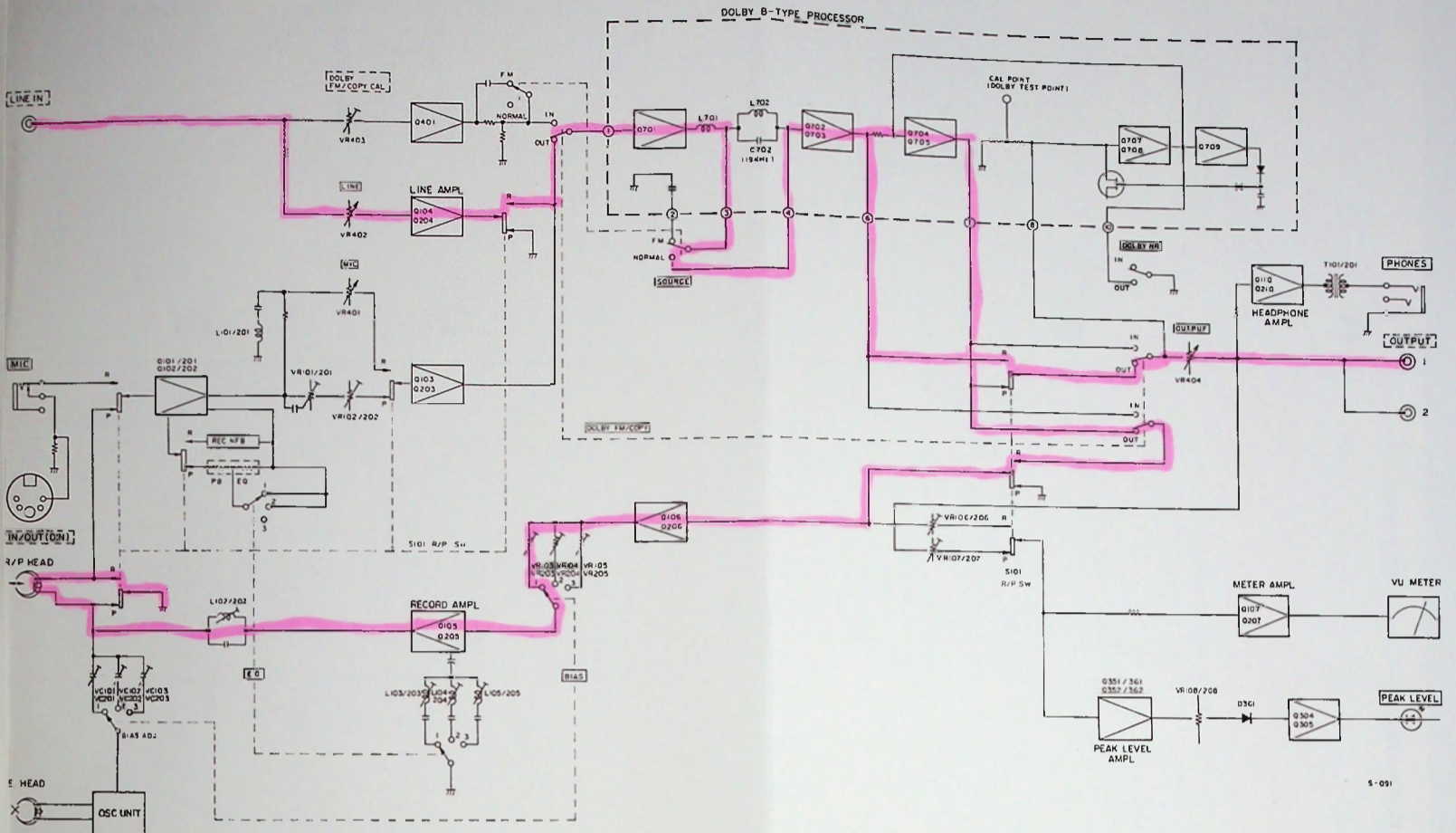

5-091

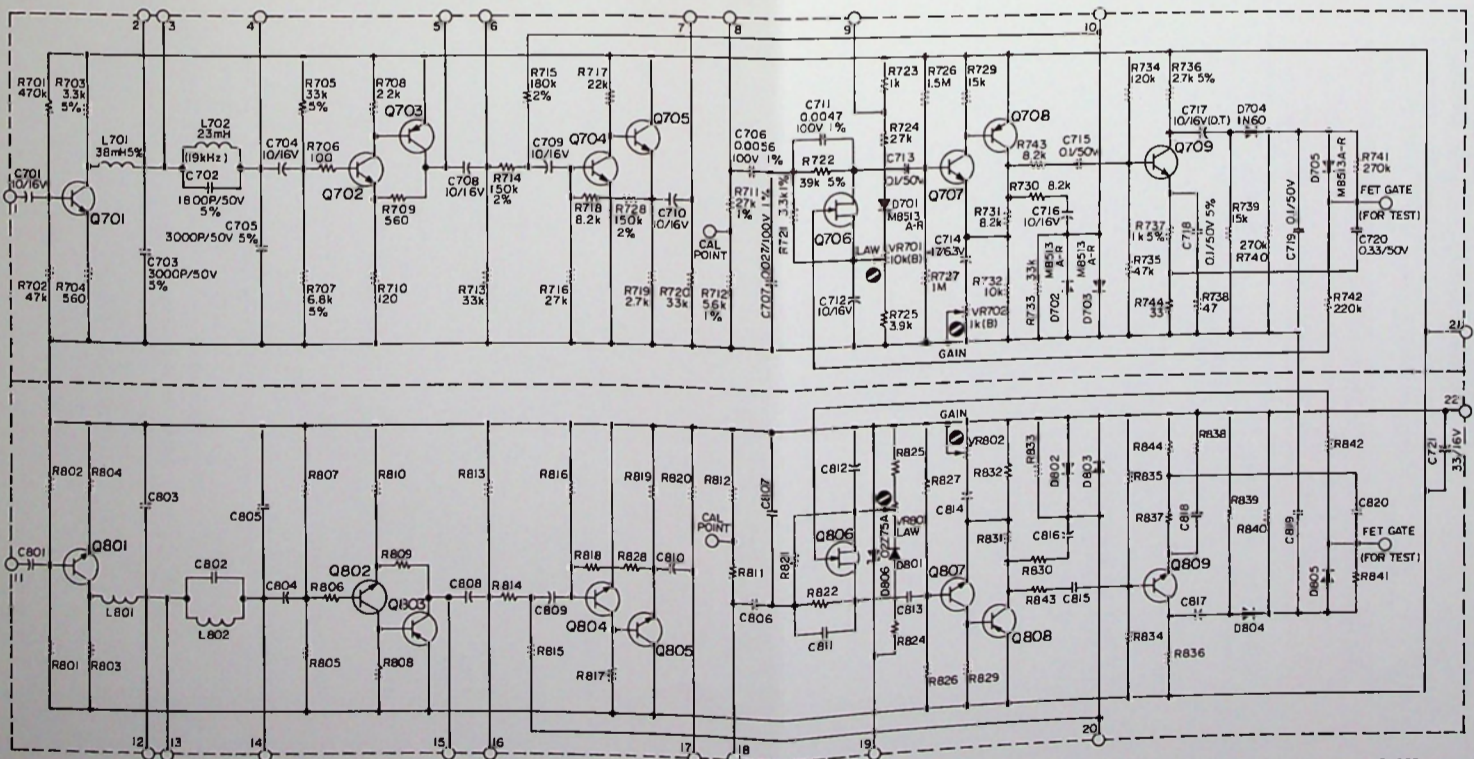

5-083

| CIRCUIT REF. NO. | DESCRIPTION | CIRCUIT REF. NO. | DESCRIPTION |
|------------------|-------------|------------------|------------------------|
| Q701 / Q801 | 2SC1327(T) | Q706 / Q806 | 2SK30(DA) or 2SK30(DB) |
| Q702 / Q802 | 2SC644(S) | Q707 / Q807 | 2SC1327(T) |
| Q703 / Q803 | 2SA666(S) | Q708 / Q808 | 2SA666(S) |
| Q704 / Q804 | 2SC644(T) | Q709 / Q809 | 2SC644(T) |
| Q705 / Q805 | 2SC644(S) | | |

NOTE

- ALL RESISTORS ARE 1/4 WATT, 5%, UNLESS MARKED OTHERWISE. RESISTOR VALUES ARE IN OHMS (k=1000, M=1,000,000).
- ALL CAPACITOR VALUES ARE IN MICROFARADS (p=PICO-FARADS).

| | | | |
|---|-------|--|--|
| 6 | | | |
| 5 | | | |
| 4 | | | |
| 3 | | | |
| 2 | 03-76 | | |
| 1 | 12-75 | | |

DOLBY NR

TEAC CORPORATION

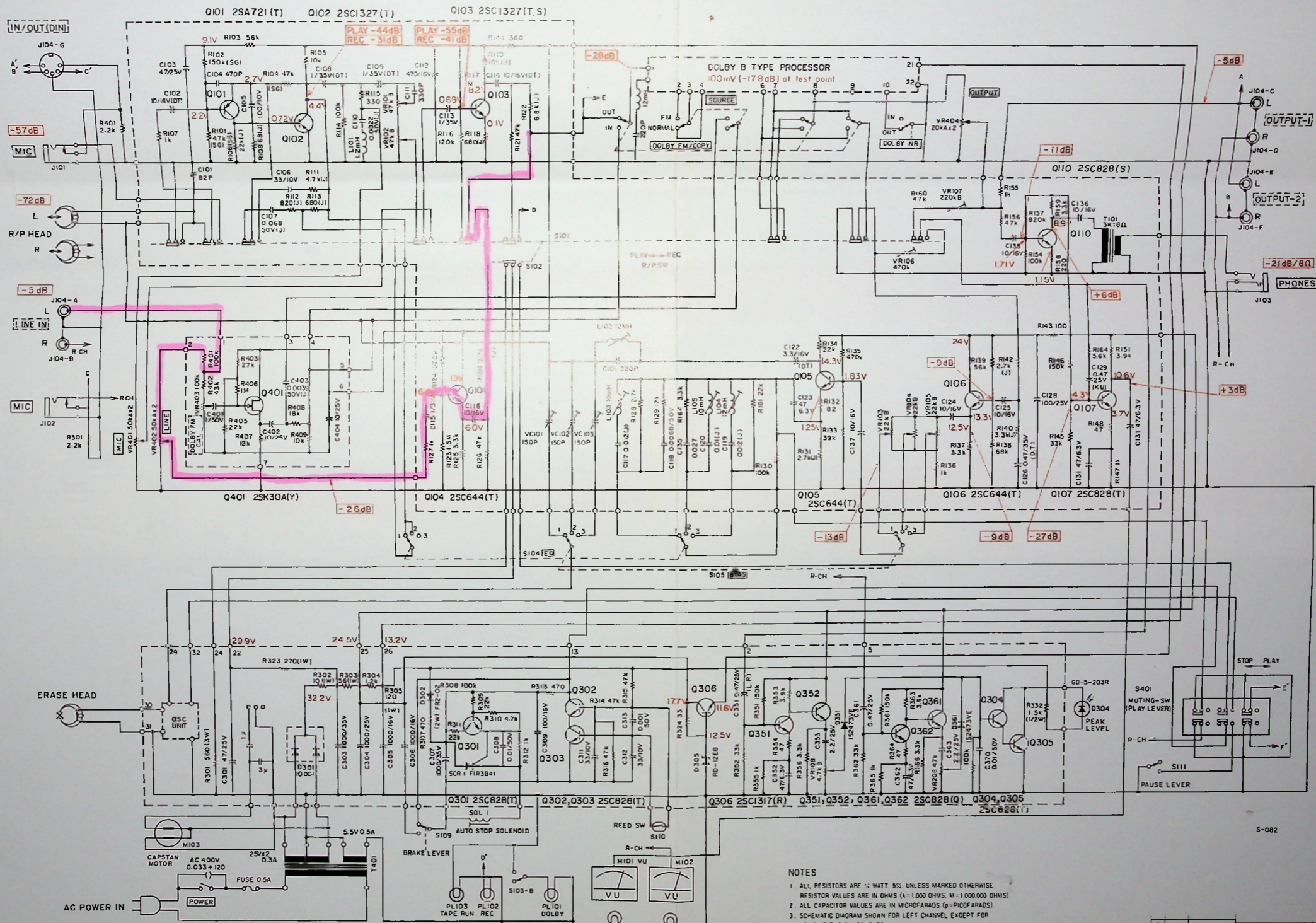

- NOTES**
1. ALL RESISTORS ARE 1/4 WATT, 5% UNLESS MARKED OTHERWISE. RESISTOR VALUES ARE IN OHMS (K=1,000 OHMS, M=1,000,000 OHMS)
 2. ALL CAPACITOR VALUES ARE IN MICROFARADS (P=PICOFARADS)
 3. SCHEMATIC DIAGRAM SHOWN FOR LEFT CHANNEL EXCEPT FOR SOME OF THE COMPONENTS
 4. DC VOLTAGES WERE MEASURED DURING PLAY MODE
 5. SIGNAL LEVELS (dB) WERE MEASURED WITH INPUT AND OUTPUT CONTROLS AT SPECIFIED POSITION
 6. READING IN dB REFERENCED TO 0dB=0.775V