

Tektronix®
COMMITTED TO EXCELLENCE

FM BROADCAST MEASUREMENTS USING THE SPECTRUM ANALYZER



FM BROADCAST MEASUREMENTS USING THE SPECTRUM ANALYZER

by Clifford B. Schrock

I. Introduction: The Stereophonic Spectrum

II. Equipment Performance Measurements

- A. Preparing Equipment
 - B. Audio Frequency Response
 - C. Harmonic Distortion
 - D. Output Noise Level (Fm)
 - E. Am Noise
 - F. Separation
 - G. Crosstalk
 - H. Subcarrier Suppression
- } Mono Proof

III. Monitoring Requirements

- A. Frequency: carrier, subcarrier, and SCA
- B. Modulation and Deviation: carrier, subcarrier,
SCA and composite makeup
- C. Antenna Pattern
- D. Spurious Emission

IV. Day-to-Day Maintenance

- A. Console Tests
- B. S/I Performance
- C. Intermodulation; Audio
- D. Intermodulation; Transmitter
- E. Crosstalk Using Program Material
- F. Pilot Interference
- G. Dolby Fm
- H. Antenna, Filter, and Feedline Testing

The author would like to thank Morris Engelson, Linley Gumm, and Bill Warner for their help in preparing this booklet. Collins Radio, Harris Corp., and FCC personnel reviewed and commented on the manuscript.

Cover photo courtesy of KPAM, AM and FM, Portland, Oregon

Copyright © 1977, Tektronix, Inc. All rights reserved.

I. Introduction: The Stereophonic Spectrum

This application note explains how to use and interpret spectrum analysis of the fm stereo system.

The fm system approved for use by the FCC in the U. S. uses a complex modulation system to achieve a compatible mono/stereo system of broadcasting. In a simple monaural system, the fm channel is frequency modulated ± 75 kHz with the audio information. To achieve a compatible system, when stereo is transmitted, the same monaural (left plus right channel combined) remains in the 0 to 15 kHz position of the transmitted frequency spectrum. This monaural signal, however, cannot be modulated ± 75 kHz, since it would occupy the total frequency spectrum available for an fm station. Instead, the monaural signal is modulated only 45%, average. The second component of a stereo transmission is the pilot carrier at 19 kHz. This 19 kHz pilot carrier modulates the fm channel 8 to 10%. On a monaural station receiver, the pilot would not be heard at 19 kHz, since it is beyond the normal human hearing limit. In an fm stereo receiver, the pilot carrier signals that the transmission is stereo (sometimes lighting an indicator). The third part of the stereo transmission is the sub-channel which is a double sideband suppressed carrier signal (DSSC). This subcarrier is a left-subtracted-from-right (L-R) signal, which, when fed through a matrix with the monaural main channel in the receiver, forms the individual left and right channels. The 38 kHz channel is transmitted without a carrier (suppressed carrier). The 38 kHz carrier is obtained in the receiver from the 19 kHz pilot and reinserted on the sub-channel prior to detection. The sub-channel is modulated 45%, so that the total modulation for an fm stereo station is main channel 45%, pilot carrier 10%, and sub-channel 45%. The total is 100%. The only other possible signal in the modern station is an SCA usually used for background music. This is an extra audio channel carried at 67 kHz and is generally modulated 10% in a stereo station. Since the total modulation cannot be over 100%, stereo stations with an SCA reduce the

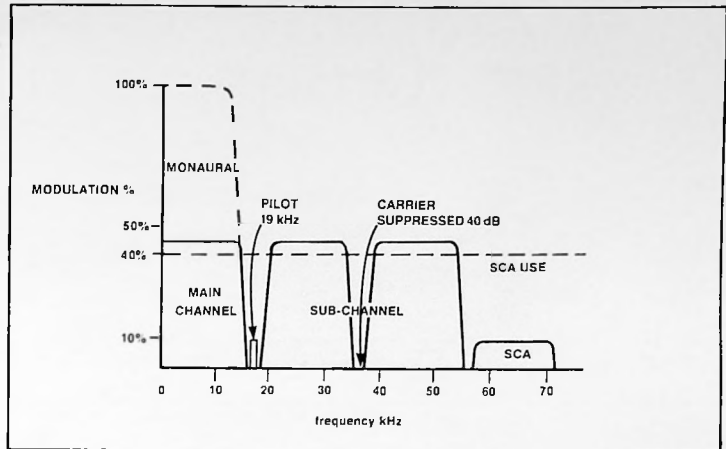

Fig. 1. The Composite Fm Stereo Spectrum

main and sub-channel modulations to 40% each.

This combination then gives main channel 40%, pilot 10%, sub-channel 40%, and SCA 10%. The total is 100%. An audio spectrum analyzer can be used to show all these components and their relative levels and interactions. The signals can be checked at the composite output of the stereo generator. The theoretical channel occupancy is shown in figure 1.

A theoretical diagram of an fm stereo generator is shown in figure 2. Both the left and right channels are pre-emphasized just as a normal monaural signal would be. Then the left and right signals are both added and subtracted in

a matrix. The channels added (L+R) form a monaural signal. This is the main channel. The subtracted channels (L-R) are modulated on a 38 kHz carrier, to form the sub-channel. Since a balanced modulator is used, the carrier at 38 kHz will be suppressed, leaving only the modulated audio information. The 38 kHz oscillator is divided by 2 to make the 19 kHz pilot. The three signals: main channel, sub-channel, and pilot are combined in the proper ratios (45, 45, 10%) forming the composite output.

In an actual fm facility, a slightly different type of stereo generator is used which produces the same result as the theoretical generator by using a switching technique. After pre-emphasis, a simple

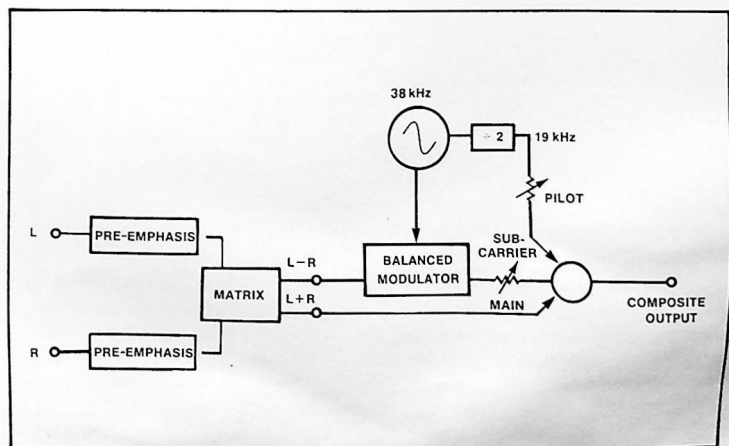

Fig. 2. Block Diagram of Theoretical Fm Stereo Generator

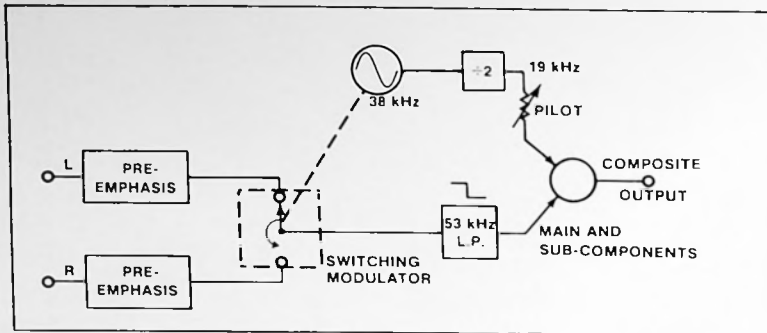

Fig. 3. Block Diagram of a Switching-type Stereo Generator

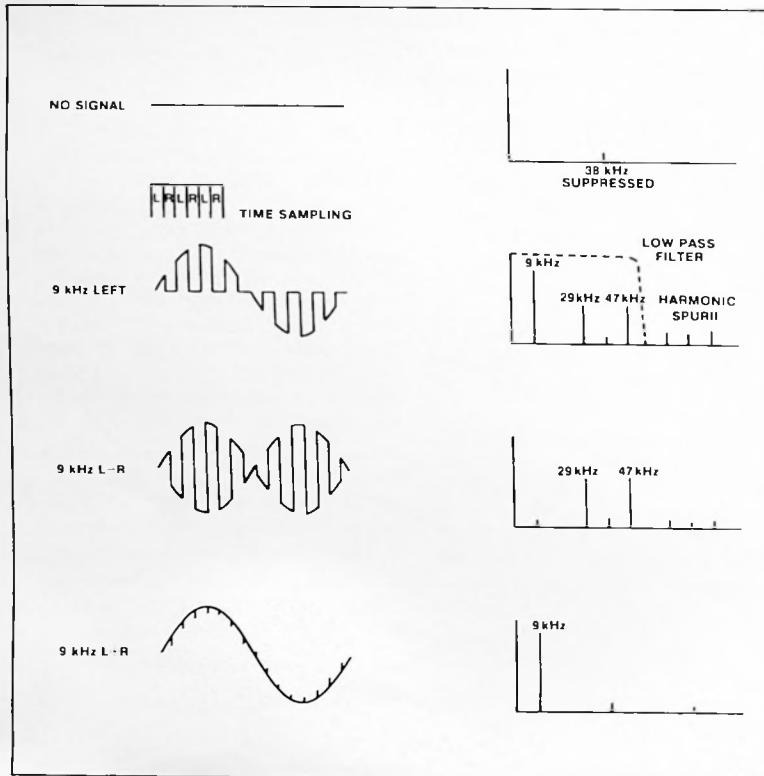

Fig. 4. Time and Frequency Components Generated in a Switching-type Stereo Generator

electronic switch (figure 3) commutates between the left and right channels. The switching occurs at 38 kHz and forms all of the main and subchannel components as shown in figure 4. Because of the sharp switching transient, high harmonics are also produced. The harmonics are generally filtered with a low pass filter. Some manufacturers have devised schemes to eliminate or reduce

the generation of the high harmonics so that the low-pass filter can be simpler, and less phase distortion will be present due to the filter. These schemes involve special sampling waveforms with low harmonic content.

A display similar to the theoretical diagram (figure 1) will be obtained on the spectrum analyzer by sweeping the left

and right channels of a stereo system with an audio generator (figure 5). The pre-emphasis curve with 17 dB of rise, is prominent in both the main and sub-channels. The sub-channel sidebands as generated are 6 dB lower than the main channel; although, after detection, they would add together and the resultant power would be equal to the main channel. In figure 5, notice the pilot carrier at 19 kHz and the absence of the subcarrier, which has been suppressed, at 38 kHz. Figure 6 is a spectrum display of the main, sub-, and SCA channels obtained by using a de-emphasized sweep. Figure 7 is a display of an fm stereo signal on an rf spectrum analyzer. Because the signal is fm, it cannot be interpreted as readily as the baseband composite signal; however, many key components and frequencies can be seen.

II. Equipment Performance Measurements

The FCC requires that yearly measurements be performed on fm transmitters and facilities to insure compliance with certain minimum standards.

The fm proof on a monaural station requires only four checks: frequency response, harmonic distortion, am noise,

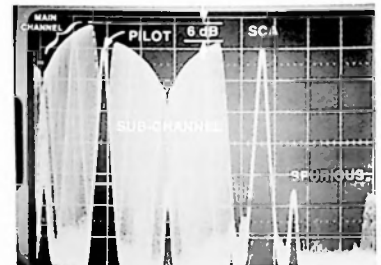

Fig. 5. Display of Composite Fm Stereo Signal on Low Frequency Spectrum Analyzer

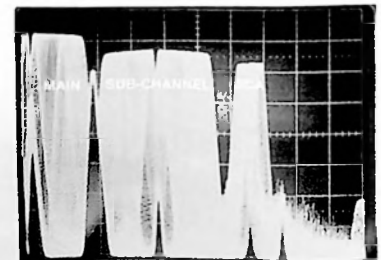

Fig. 6. Composite Fm Stereo Signal Display Obtained by Sweeping with a De-emphasis Filter

and fm noise. A station broadcasting stereo programming is also required to check separation, crosstalk and sub-channel suppression.

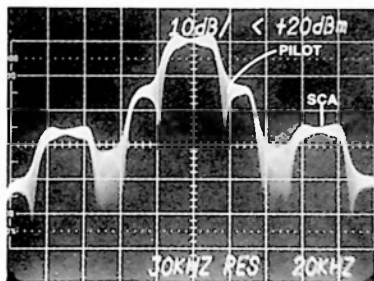

Fig. 7. Fm Stereo Station with SCA on Rf Spectrum Analyzer

Traditionally, Equipment Performance Measurements have been performed using the station modulation monitor and a distortion analyzer. An oscilloscope is used for the stereo adjustments. By substituting an audio spectrum analyzer for many parts of the proof, much more information can be obtained. Interactions between the main channel and the sub-channels in stereo stations can be noted, and sources of many intricate problems can be easily diagnosed once the operator becomes familiar with spectrum analysis.

In some instances it is possible to make measurements directly at rf using a high-frequency spectrum analyzer. Direct rf measurements have many advantages, including the elimination of non-linearities of the modulation monitor.

A. Preparing Test Equipment

The accuracy of the proof depends upon the quality of the test equipment and also the care with which it is connected, calibrated, and used. The sensitivity of the spectrum analyzers we recommend demands the best engineering practices during measurements, otherwise, the results may be masked by effects such as leakage and rf within the test lash-up.

Test Equipment Recommended for Audio Measurements

1. Low-frequency spectrum analyzer, such as the 5L4N, and appropriate 5000 Series mainframe. The use of a 5111 storage mainframe is recommended.
2. Audio generator such as the SG 502.

3. Matching transformers (2 required for stereo) such as W.E. 111C or U.T.C. A-20.
4. De-emphasis filter (figure 10).
5. Matching pads as appropriate.
6. Miscellaneous patch cables.

Test Equipment for Rf Measurements

1. High-frequency spectrum analyzer, such as 7L12 or 7L13, and appropriate 7000 Series mainframe. A storage or variable-persistence mainframe is recommended.
2. Preamplifier such as 7K11 CATV Preamplifier.
3. Frequency Counter such as DC 502 or 7D14.

Other Applicable Equipment

1. 600-ohm step attenuator such as Tektronix model 011-0093-00.
2. Dipole antenna (see figure 48).
3. Vertical amplifiers for mainframe such as 5A45 or 7A15.

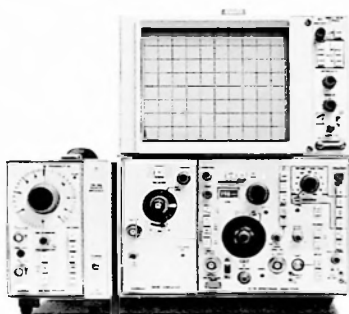

Fig. 8. TEKTRONIX 5L4N Audio Spectrum Analyzer and SG 502 Audio Oscillator



Fig. 9. TEKTRONIX 7L12 Rf Spectrum Analyzer and 7K11 Rf Preamplifier

4. Rf bridge such as Hewlett Packard 11652A Reflection/Transmission Kit.

Checking the Test Equipment

This test should be performed on location at the station to insure that stray rf fields do not interfere with the measuring equipment. First, each piece of audio equipment should be checked to insure that the internal calibration is correct.

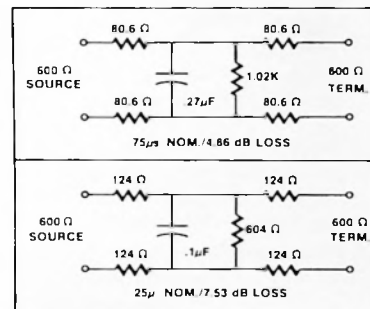

Fig. 10. Details for Constructing De-emphasis Filters for 25 and 75 Microsecond Characteristics (All Components 1% Tolerance)

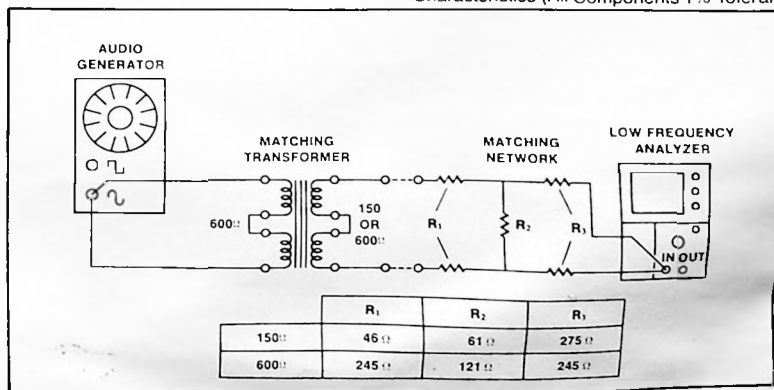

Fig. 11. Setup to Check Test Equipment and Details of Matching Pads

The 5L4N has a detailed calibration procedure in the operating manual. An external 5 watt 20 dB 600 ohm pad must be used ahead of the 5L4N to extend the measurement range from -10 dBm to +10 dBm full screen. Details of pads are shown in figures 10 and 11.

The audio generator should be connected through a matching transformer to the 5L4N as shown in figure 11. The transformer is necessary to insure measurements free of noise and hum.

1. Set the 5L4N to -10 dBm REF LEVEL and select 600 INT TERM 'on'.
2. Check the output level of the audio generator in the MAX position with all attenuation pushbuttons 'out'. The analyzer should indicate a full screen signal (+10 dBm through the 20 dB pad with the analyzer input attenuator set at -10 dBm).
3. Check the harmonic content of the audio generator by looking at a 0 to 20 kHz span on the analyzer. Tune the generator frequency from 20 Hz to 15 kHz and note that the harmonics are at least 70 dB below the desired tone (figure 12).
4. Check the flatness of the matching transformers using the tracking generator output of the 5L4N instead of the audio generator. It should have virtually flat response from 20 Hz to 20 kHz. Any error should be noted for future reference (figure 13).
5. Finally, reconnect the generator and set the output level to minimum with all attenuation 'in'. The baseline of the analyzer display should be clean and free of noise and spurious responses from 0 to 20 kHz.

The high-frequency spectrum analyzer should be calibrated using the instructions in the operating manual. In the high rf environment around the fm transmit-

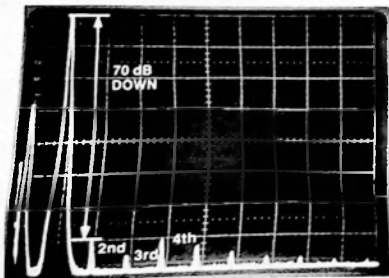

Fig. 12. Checking Harmonic Distortion of Audio Generator

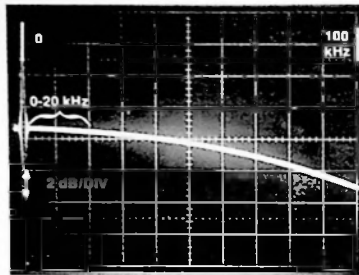

Fig. 13. Checking Frequency Response of Matching Transformer

ter, the analyzer should be checked with the input terminated to verify that spurious responses are not occurring within the analyzer. Grounding of the main-frame may be necessary to insure that spurious free measurements can be made.

The Test Setup

Test points for the performance measurements should be located in the station as shown in figure 14. The 5L4N audio frequency Spectrum Analyzer should be connected to the output of the modulation monitor (test point ⑥). The microphone input in the main control room should also be accessible (test point ②). The test equipment should be well grounded, and shielded cable should be used for all connections. If it is not possible to locate the generator and analyzer in the same room (such as when an *stl* is used) then locate the generator in the control room and place the modulation monitor at the transmitter site along with the audio frequency spectrum analyzer.

Signal processing AGC circuits should be defeated, although every attempt should be made to perform mea-

surements with all equipment left in the processing chain. Most AGC-type processors have built in defeat switches that turn 'off' the gain control loop without disturbing the signal path. While patching around processing units is not prohibited, it would be considered illegal to intentionally patch around any device that alters the frequency response (i.e. equalizers). This applies only to frequency altering devices normally used between the board output and the transmitters.

Legal Requirements

FCC rules (§73.93) require that the proof be performed by the holder of a first class license. Descriptions of the equipment used, equipment connections and an equipment list is also required. All pertinent data such as equipment serial numbers, time of tests, persons who assisted, accuracy capability of the test equipment, equipment removed or disabled, equipment connections, and personal recommendations or observations must be incorporated into the final proof.

B. Frequency Response

Frequency response is a measure of the ability of the transmitting chain to pass frequencies required for faithful audio reproduction. The *fm* transmitting system uses a pre-emphasis network in the transmitting chain and a de-emphasis network in the receiver. 75 μ s of pre-emphasis is commonly used except in Dolby stations. The transmitting system must have a frequency response that conforms as closely as possible to the pre-emphasis curve (figure 15) with a tolerance of no more than 3 dB below the curve (in the direction of minimum deviation).

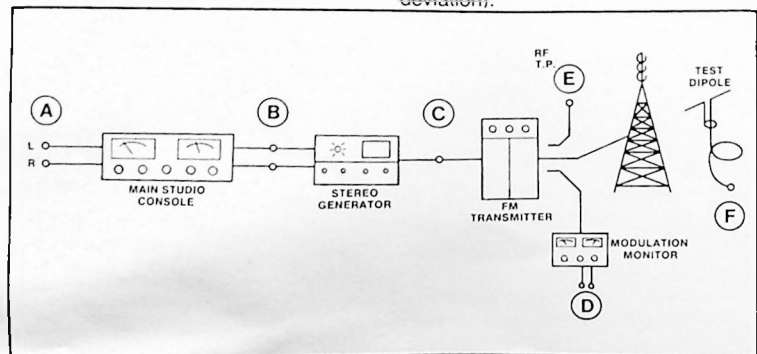

Fig. 14. Typical Fm Station Block Diagram Showing Test Points for Performance Tests

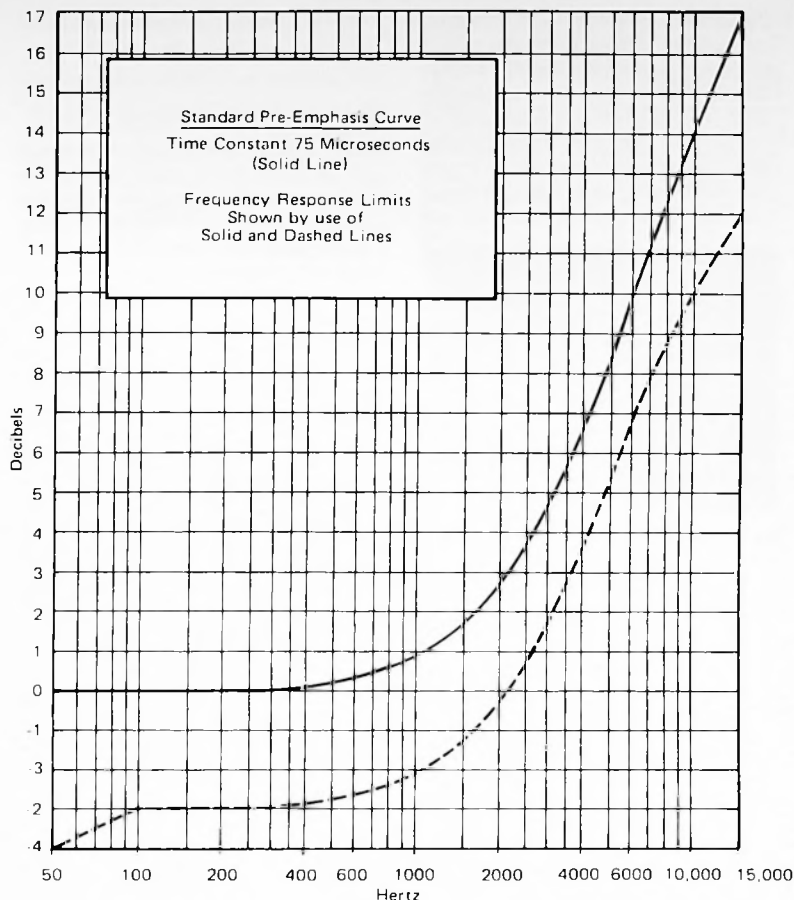

Fig. 15. Standard 75 μ s Pre-emphasis Curve

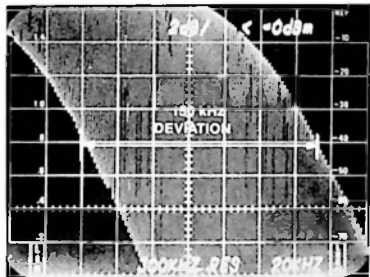

Fig. 16. 100% Modulation Indication on Rf Spectrum Analyzer

Many possibilities exist for measuring the transmitter chain frequency response. The best indication can be obtained using the station modulation monitor to indicate 100% modulation, and supplying audio through a step attenuator. If the calibration of the monitor

is in doubt, then a high-frequency spectrum analyzer can be substituted for use as a modulation indicator.

Assuming the station modulation monitor can be trusted, the response of the transmitter and individual stereo and SCA channels can be rapidly checked with an audio spectrum analyzer. The audio spectrum analyzer is especially useful for response tests on a regular basis since the response can be verified in a matter of minutes. This permits monthly or even weekly tests if desired.

In addition to response tests, the specification for spurious responses and the action of the audio lowpass filters (generally 17 kHz) can be checked.

Measurements at Rf.

A high-frequency spectrum analyzer is

used as an indicator of modulation for 25, 50, and 100% modulation, and a gain set attenuator is used to accurately measure the deviations from the pre-emphasis curve.

1. Carefully calibrate the spectrum analyzer. Additionally, the frequency span should be checked with a 20 kHz square wave audio tone to verify the calibration of the narrower spans used for this test.
2. Modulate the transmitter through a 600 ohm attenuator with a 1000 Hz tone until the spectrum analyzer indicates a deviation of 150 kHz (\pm 75 kHz) as shown in figure 16. This is 100% modulation for a monaural fm station.
3. The 1000 Hz point is zero reference on the step attenuator. Set the tone to 50 Hz and use the step attenuator to reset the modulation to 150 kHz deviation. Note the attenuator difference in dB from the zero reference point.
4. Continue the test for frequencies of 100, 400, 1000, 5000, 10,000, and 15,000 Hz. The results can be plotted on a diagram of the pre-emphasis curve (figure 15). Deviations from the 75 μ s pre-emphasis curve indicate frequency response variations.
5. Repeat the tests for 25% modulation, by driving the transmitter with a reference tone until the spectrum analyzer indicates a deviation of 37.5 kHz.
6. Repeat the test for 50% modulation (75 kHz indication on the spectrum analyzer).

Stereo Stations

1. Proceed as above except that 100% modulation of each stereo channel is 45% of the total modulation envelope. This will be indicated on the spectrum analyzer by a deviation of 67.5 kHz when either the left or right channel is driven with a single audio tone. Each stereo channel should match the 75 μ s pre-emphasis curve.
2. Repeat the test on each stereo channel for levels of 25% modulation (16.9 kHz) and for 50% modulation (33.75 kHz).

Stereo Stations with SCA

Use the procedure outlined for monaural stations except that the channels should be driven with audio tones with 100%

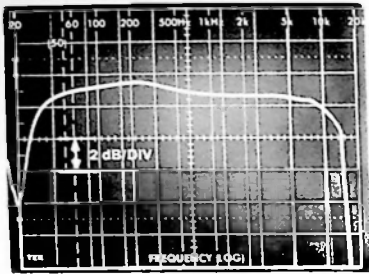

Fig. 17. Typical Response of Fm Station Checked through De-emphasis Circuit in Modulation Monitor

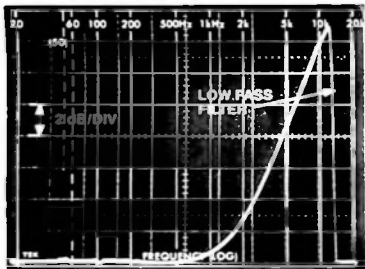

Fig. 18. Pre-emphasis Response from Composite Output on Modulation Monitor

modulation being 40% of the total envelope. The spectrum analyzer should indicate 60 kHz deviation for 100%, 15 kHz for 25% and 30 kHz for 50%.

Procedure for Frequency Response Measurements at Audio

A low-frequency spectrum analyzer can be used to quickly verify the frequency response of the transmitter through the modulation monitor. This is not a proof-of-performance test since the modulation changes with frequency due to the pre-emphasis curve.

Note: A simple de-emphasis network can be built for use with any 600 ohm source. This filter will permit audio swept measurements of the transmitter while maintaining 100% modulation. If the network is used (figure 10) it is recommended that the response of the network be carefully checked after construction to verify that the response is complementary to the standard pre-emphasis curve.

1. Using the 5L4N Spectrum Analyzer, connect the tracking generator output to the audio console. Using MANUAL, set the frequency to 400 Hz. Set the level, as indicated on the modulation monitor, to 17 dB below 100% modulation. This setup is necessary to insure that the transmitter is not overmodulated as higher audio frequencies are

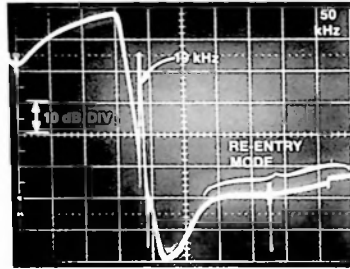

Fig. 19. Pre-emphasis Response in 10 dB/div Mode

passed through the transmitter.

2. Connect the spectrum analyzer to the audio output of the modulation monitor and sweep the analyzer from 20 Hz to 20 kHz. In the normal (de-emphasized) output the response should be flat, as shown in figure 17.
3. Switch the monitor to the composite output and sweep the transmitter. The pre-emphasis curve of the transmitter will be displayed as in figure 18.
4. Sweep the stereo generator-transmitter combination from 0 to 50 kHz in 10 dB/div mode. Check for low level re-entry points and the 19 kHz intersect point (Figure 19).

Stereo Response at Audio

1. Introduce a 400 Hz audio signal from the tracking generator output of the 5L4N to the left channel input 17 dB below 100% modulation of the left channel, as indicated on the modulation monitor. Sweep the spectrum analyzer. A flat display should result from 50 to 15,000 Hz. Roll-off above

15 kHz should be noted due to the 17 kHz lowpass filters (figure 18).

2. Repeat the test for the right channel.

SCA Response (Not required for proof)

1. Connect the tracking generator output of the 5L4N to the SCA input on the transmitter exciter and modulate the channel to 100%, as indicated on the modulation monitor. Sweep the channel with the spectrum analyzer. Most SCAs operating at 67 kHz have a response up to 5 kHz, at which point they roll off.
2. Other channels, such as telemetry

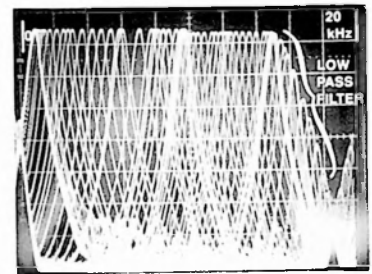

Fig. 20. Checking Audio Response Using Slow Sweep and Storage

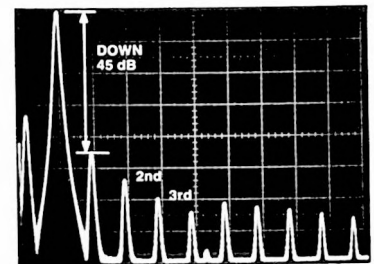

Fig. 21. Typical Harmonic Distortion Measurement

channels, can be checked in a similar manner using the tracking generator in the spectrum analyzer.

Note: If it is not practical to operate the spectrum analyzer/tracking generator in a location where there is access to both ends of the transmitting chain, an audio generator can be substituted for the tracking generator. Use the 5L4N in a storage mainframe and slowly move the audio generator from the low frequency limit to the high limit. A display similar to that shown in figure 20 will be obtained.

C. Harmonic Distortion

Harmonic Distortion or combined audio harmonics [§ 73.317 (a, 2)] is the arithmetic sum of the amplitudes of all the separate harmonic distortion components. This is the most common distortion test performed on transmitters, and is measured by passing a pure sine-wave tone (at 1000 Hz for example) through a transmitter and measuring the sum of all the components (2000, 3000, 4000 Hz etc.).

dB DIFFERENCE	ADD TO HIGHER LEVEL
Same (0dB)	3.01
1 dB	2.54
2	2.13
3	1.76
4	1.46
5	1.19
6	.97
7	.79
8	.64
9	.51

Fig. 22. Chart to Sum Harmonics

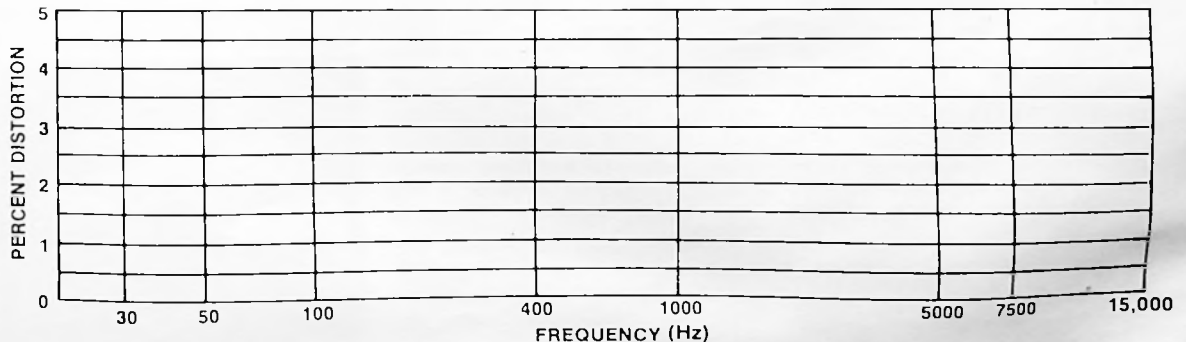

Fig. 24. Use this Chart to Record Results of Harmonic Distortion Tests

RATIO in dB	% of READING	RATIO in dB	% of READING
20. (40:60)	10% (1% .1%)	30 (50:70)	3.16% (.31, .031%)
21	8.9	31	2.87
22	7.94	32	2.51
23	7.08	33	2.24
24	6.31	34	2.00
25	5.62	35	1.78
26	5.01	36	1.59
27	4.47	37	1.41
28	3.98	38	1.26
29	3.55	39	1.12

Fig. 23. dB to Percent of Distortion Conversion chart

The low-frequency spectrum analyzer presents a graphic display for analysis of the harmonics of an audio signal. This technique also makes it possible to differentiate between harmonics, and noise and hum that might also be on the transmitted signal. In the case of fm stereo installations, other frequency components besides harmonics can occur due to an incorrectly adjusted stereo generator, and these can be readily identified so that the problems can be solved.

The 5L4N audio Spectrum Analyzer in combination with a good audio generator (such as the SG 502) can make 70 dB (0.034%) harmonic distortion measurements.

Procedure for Harmonic Distortion Measurement at Audio

1. Connect an audio generator (such as the SG 502) to the microphone input, of the transmitter (test point Ⓐ). Set the generator to 1000 Hz and set the microphone fader to mid-range. Increase the generator output until 100% modulation is indicated on the modulation monitor.
2. Connect the low-frequency spectrum analyzer to the monitor output Ⓢ. Set the analyzer controls to 10 dB/div, 1 kHz/div, and select a center frequency of 5 kHz. A display of the 1 kHz tone should be observed on the second graticule line from the left edge of the screen.

- Harmonic distortion is measured by noting the difference in amplitude between the fundamental tone (1 kHz in this case) and the sum of the harmonics (second, third, fourth, etc.).
- The sum of the harmonics can be easily added using the chart in figure 22. Harmonics that are more than 10 dB below the other harmonics contribute little relative power and do not normally have to be computed.
- The difference between the fundamental and the harmonics is measured in dB as shown in figure 21. These numbers may be converted to percentage of distortion using the chart in figure 23. Record the results in a chart like the one shown in figure 24.
- Continue harmonic distortion measurements for the fundamental frequencies 50, 100, 400, 1000, 5000, 10,000, and 15,000 Hz at 100% modulation as indicated on the modulation monitor. Harmonics should be measured to 30 kHz.
- Harmonic distortion measurements must also be made on the fundamental frequencies of 50, 100, 400, 1000, and 5000 Hz at 25 and 50% modulation.

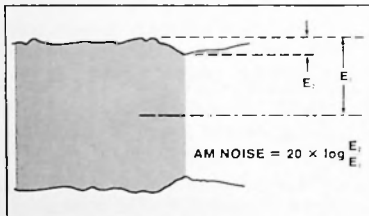

Fig. 25. Amplitude Variations of the Fm Envelope Causing Am Noise

Harmonic Distortion Measurements on Fm Stereo Stations

- Use the same procedure as above except that the left and right channels should be done separately and measurements should be made using either 40% or 45% modulation as the 100% reference point, depending upon the station configuration (stereo or SCA).

D. Am Noise

Am noise occurs in two ways in an fm transmitter. It can occur in the lower level stages, appearing around the unmod-

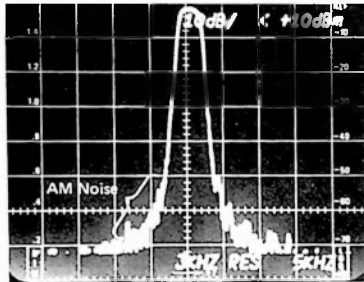

Fig. 26. Residual Am Noise Measurement

ulated carrier much as it would occur in an am transmitter. It can also appear as an effect of improper transmitter tuning. If the 150 kHz bandpass of the transmitter is not virtually flat, then deviation will also impart amplitude variations on the carrier (figure 25).

Am noise can generally be measured using the built-in test on the station modulation monitor. However, for troubleshooting or where more insight into a problem is desired, the high-frequency spectrum analyzer can be a great help. A procedure for accurate tuning of the final stages of the transmitter for best am noise is shown below. In addition, another technique for sweeping the fm transmitter with a low frequency audio signal is demonstrated.

Measuring Am Noise

- Check the residual am noise with a high-frequency spectrum analyzer such as the 7L12 or 7L13. Tune to the unmodulated carrier using 10 dB/div and 3 kHz RESOLUTION. Using the 300 Hz VIDEO FILTER, note any humps in the noise floor around the carrier, indicating noisy low level stages in the transmitter as shown in figure 26.
- Check for modulation noise by feeding the transmitter 50 or 60 Hz at 100% modulation. Use the ZERO SPAN mode and 300 kHz RESOLUTION. Note any modulation components on the carrier tips as shown in figure 27.
- To minimize amplitude modulation components, tune the transmitter and any transmission line traps to produce a completely flat display across the 150 kHz bandpass of the transmitter.

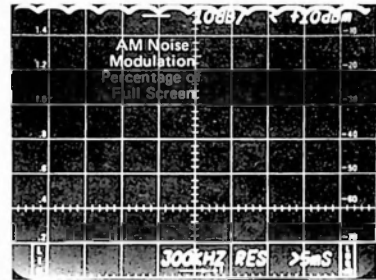

Fig. 27. Modulated Am Noise Measurement

Sweeping the Fm Transmitter (To Optimize Tuning and Am Noise Performance)

- Connect an audio oscillator to the input of the transmitter. In stereo installations, connect both channels in phase. Switch 'off' the stereo monaural mode.
- Connect an rf spectrum analyzer to an rf test point in the transmission line. Select a moderate sweep speed, 20 kHz/div, and storage mode if available.
- Modulate the transmitter with a 30 Hz tone and modulate in excess of 100%. **NOTE:** This test will swing the transmitter in excess of its standard deviation and could cause interference to adjacent fm channels. Appropriate precautions as to time and duration should be observed.
- A display of the transmitter bandpass will be obtained on the spectrum analyzer (figure 28). The tuning should be flat across the normal 150 kHz bandwidth of the transmitter for optimum stereo and am noise performance. Adjustments should be made to insure flat response.

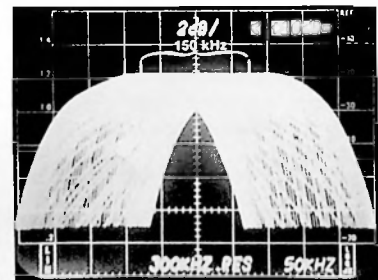

Fig. 28. Self-Sweeping an Fm Transmitter

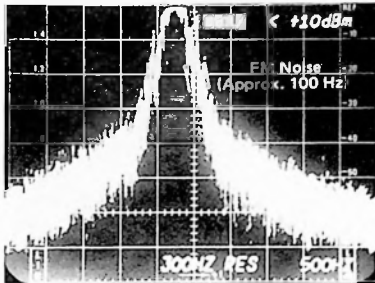

Fig. 29. Fm Noise Measurement

E. Fm Noise

Fm noise is a measure of the amount of residual fm remaining when all modulation is removed from the transmitter. Due to the pre-emphasis curve used with fm transmission, the noise when received (and subsequently de-emphasized) will have a greater low-frequency component than amplifier-type white noise.

1. Disconnect the transmitter audio input or composite generator and terminate or short the input terminals.
2. Connect a high-frequency spectrum analyzer to an appropriate rf testpoint on the transmission line.
3. Set the spectrum analyzer to a narrow SPAN and RESOLUTION and note any horizontal jitter. This jitter, if detected, can be related to the 100% modulation limit of the transmitter. For example, if 150 Hz of jitter were noted, and the 100% transmitter modulation limit is 150 kHz, then the percent of fm noise is 1/100th or 40 dB down.

F. Separation

Stereo separation is a measure of how well the left and right channels remain separated from each other throughout the broadcast chain. It is measured by loading one channel with an audio signal, and measuring the amount of signal that 'bleeds' across into the other channel.

Poor separation in the modern fm stereo facility can most often be traced to the studio, and occurs because of leakage in the console or poor phone line separation. Within the transmitter stereo exciter, improper adjustment of the pilot phase of the transmitter (or the modulation monitor) and an improper gain relationship between the main and the sub-channels can also cause separation problems.

Separation can be measured by using either a modulation monitor or an audio spectrum analyzer. The spectrum analyzer will permit separation measurements directly readable in dB across the entire audio spectrum. For the purpose of isolating a separation problem, it is recommended that the system be tested in two parts, from the studio to the input of the stereo generator, and from the stereo generator to the modulation monitor.

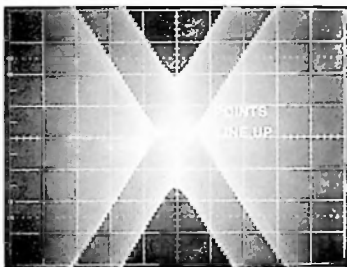

Fig. 30. Left Minus Right (L-R) Signal Used to Check Pilot Phase

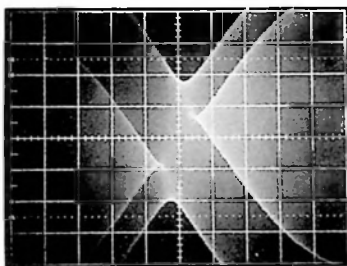

Fig. 31. Pilot Phase is Not Adjusted Correctly

CAUTION: Before attempting to measure either separation or crosstalk, the pilot phase and amplitude must be correct. In addition, the main and sub-channel amplitudes must be equal.

Note: Oscilloscope probe compensation should be checked before attempting to set pilot phase and amplitude.

To set the pilot gain and phase, the inputs to the stereo generator should be connected in parallel, but out of phase. A tone of 50 Hz should be used. This is the classic L Equals Minus R signal and will produce a pattern on an oscilloscope connected to the composite output as shown on figure 30. If the pilot phase is misadjusted it will appear as in figure 31 and should be readjusted until the pat-

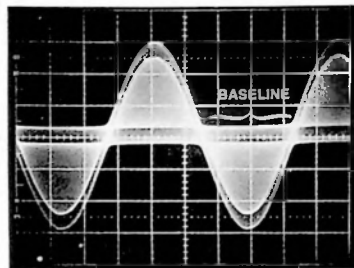

Fig. 32. Left Channel Only: Used to Balance Main and Sub-channels

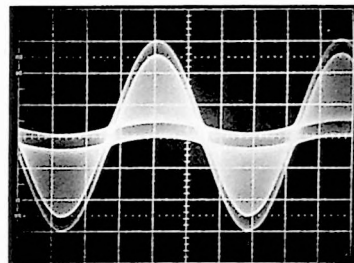

Fig. 33. Gain Between Main and Sub-channel is Wrong

tern is symmetrical. The pilot gain will interact with the phase control, and both should be adjusted until proper phase and a gain of 8 to 10% modulation is achieved.

Once the stereo generator has been adjusted, it is a good idea to check the pilot phase on the modulation monitor. Move the oscilloscope to the composite output of the modulation monitor and adjust the monitor phase controls for an identical pattern to the one obtained on the stereo generator composite output.

Now connect a 400 Hz tone to the left channel only of the stereo generator. A pattern such as the one shown in figure 32 is desired. If gain differences exist, then a pattern like the one shown in figure 33 will be noted. The gain control for the right channel should be adjusted until the baseline is flat.

Measurement of Separation with the Spectrum Analyzer

1. Assuming the transmitter has been set up correctly with regard to phase and gain, insert the tracking generator output into the left channel of the stereo generator.

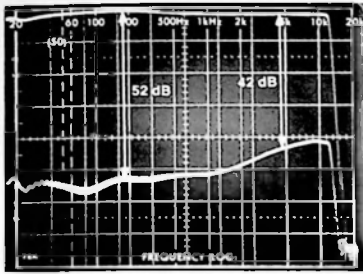

Fig. 34. Separation Measurement. Note That Separation is Poor at Higher Frequencies

- Temporarily connect the low-frequency spectrum analyzer (5L4N) to the left channel output of the modulation monitor.
- In MANUAL mode, set the spectrum analyzer to approximately 400 Hz and set the tone 17 dB below 100% modulation as indicated on the modulation monitor.
- Sweep the analyzer from 0 to 20 kHz and note the pattern. It should be flat as shown in figure 34.
- Change the analyzer input to the right and repeat the sweep. The difference between the lines in steps 4 and 5 is the separation. A dual trace display such as the one shown in figure 34 can be made with a storage scope if desired.

G. Crosstalk

Crosstalk occurs when the stereo sub-channel (23-53 Hz) modulates the main channel (0-15 Hz), or the main channel modulates the sub-channel. Intermodulation and other nonlinearities within the exciter, transmitter, and antenna system can cause true crosstalk. Crosstalk can also occur due to the music source, the console, phone lines or **stl** and amplifiers. Anything that delays or alters the gain and phase characteristics between the left and right channel will cause crosstalk. Two mechanisms generally divide crosstalk into system and transmitter crosstalk.

Since the modern **fm** stereo system uses a sum and difference type signal, any differences in gain or phase in any portion of the audio chain will cause system crosstalk. The true performance of the stereo system is measured by totally exciting either the main or sub-channel, and measuring the other non-excited

channel. If any phase or gain inequalities do exist, then system crosstalk will occur as a small portion of the non-desired channel in the matrix.

Transmitter crosstalk occurs when clean signals excite the modulator causing spurious responses in the main channel due to signals in the sub-channel (or vice versa). The most noticeable form of transmitter crosstalk occurs from the SCA to the main or sub-channels due to modulation non-linearities.

Typical tests performed with a modulation monitor cannot differentiate between the two cases of crosstalk. The low-frequency spectrum analyzer can be used to measure the individual contributions.

Testing Crosstalk with the Low-frequency Spectrum Analyzer

- Use an audio oscillator such as the SG 502 to excite both the left and right channels in phase. Connect the oscillator through a 75 μ s de-emphasis fil-

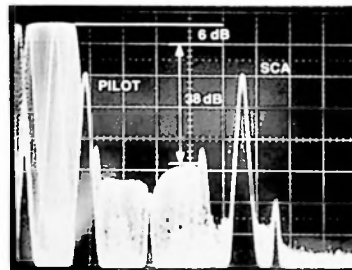

Fig. 35. Main-to-Sub-channel Crosstalk Test Shows Better than 38 dB of Isolation

- Begin with a 400 Hz tone and set both vu's on the console for exactly 100% (0 vu).
- Place the spectrum analyzer at the composite output of the stereo generator and look at a full span display (0 to 100 Hz).
- Slowly move the audio oscillator frequency from 50 Hz to 15 kHz and note the display. It should appear as in figure 35. The audio tone should appear in the main channel position from 0 to 15 Hz. Any signal noted in the 23 to 53 Hz region is crosstalk. Problems with phase differences vs. frequency across the audio spectrum will cause one or more random peaks and valleys as shown in figure 36.

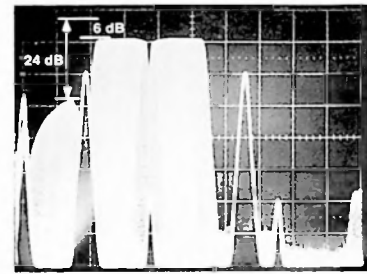

Fig. 36. Sub- to Main-channel Crosstalk Measurement. Phase Problem Causes Erratic Response in Main Channel

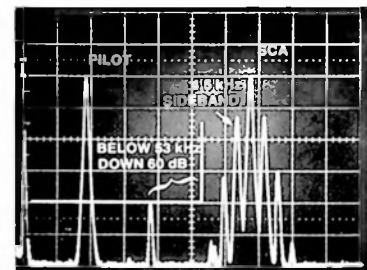

Fig. 37. SCA Crosstalk Test Using 4.5 kHz tone and 5 kHz Deviation

- A 6 dB difference normally exists between the main and sub-channels. To measure crosstalk from main to sub-channel; note the difference in dB between the frequency components and subtract 6 dB. To measure sub- to main channel crosstalk; note the difference in dB and add 6 dB.
- Move the spectrum analyzer to the composite output of the modulation monitor and repeat the test. If transmitter nonlinearities are a problem, spurious components such as harmonics of audio frequencies, sum and difference beats, etc. will appear in the display.
- Repeat the test for the sub-to-main channel crosstalk by using the same test signal with one channel out of phase with the other.

SCA Crosstalk

FCC rules have recently changed concerning the SCA carriers. The new rule states that any frequency deviation and modulating frequency can be used provided that interference in the 0 to 53 kHz portion of the composite signal is greater than 60 dB down from 100% modulation. By calculations using the Bessel null

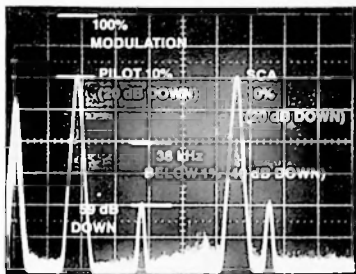

Fig. 38. Subcarrier Suppression is Referenced to 100% Modulation. It Can Also Be Compared to the 19 kHz Pilot

functions, a deviation of 5 kHz and a modulation frequency less than 4.5 kHz is the most practical combination that will protect the spectrum below 53 kHz.

To check the SCA, modulate the channel with 4.5 kHz using 5 kHz of deviation. The results should be similar to figure 37. Note that the pilot carrier is 20 dB down (10% modulation) from 100% modulation. The products produced from the SCA should be 40 dB below the pilot level in the 0 to 53 kHz region.

H. Subcarrier Suppression

FCC rules require that the subcarrier for the sub-channel (38 kHz) be suppressed by 40 dB. This is usually determined by the balance of the stereo modulator. The low-frequency spectrum analyzer can be used to look directly at the subcarrier and measure this parameter. Begin by checking the output of the stereo generator. The display should be similar to the one shown in figure 38. The balance of the modulator can be adjusted for minimum if it is not greater than 40 dB below 100% modulation reference for the transmitter. To check the subcarrier suppression at the composite output with a spectrum analyzer, the stereo pilot can be used for a reference. If the pilot is set at 10%, then it is suppressed 20 dB. The 38 kHz subcarrier should be at least 20 dB below the pilot level as shown in the figure.

III. Monitoring Requirements

A. Frequency

A frequency monitor is no longer required by the FCC. Instead it is up to the chief engineer to check the frequency of

each source within the station once a month by some means ultimately traceable to the National Bureau of Standards (N. B. S.)

For an fm station, the carrier must be held within ± 2000 Hz (§73.269) of the assigned carrier frequency. The stereo pilot must be held within ± 2 Hz (§73.297(b)) of 19 kHz, and the SCA should be within ± 500 Hz (§73.295(g)) of the frequency used. A number of procedures for these measurements exist depending upon the equipment available. A frequency monitor might still be used and is certainly recommended for day-to-day tests. Today, however, the frequency counter is almost universally accepted as the test instrument for monthly calibration. The problem is to verify the accuracy of any device used against the N. B. S. reference. The frequency measuring equipment can be sent out to a calibration service, however, most stations will prefer to use one of the following techniques.

Direct Comparison Measurement Technique

This technique can be used on most frequency counters containing a 1 or 5 MHz internal reference oscillator. A receiver or spectrum analyzer is used to monitor WWV, WWVB (60 kHz), WWVH or WWVL. A small portion of the frequency counter time base oscillator signal is coupled into the receiver as shown in figure 39. After the station (usually WWV at 5, 10, or 15 MHz) is carefully tuned in on the receiver, the frequency counter oscillator or harmonics of the oscillator are zero beat against the incoming signal. This technique is simple, although its accuracy is based upon two factors. The ability to detect a zero beat on the communications receiver may be limited to ± 20 Hz because of the lower audibility limits. The spectrum analyzer, however, can be used in ZERO SPAN to make an oscilloscope display at absolute zero beat. Secondly, when using a higher WWV frequency, such as 10 or 15 MHz, it is difficult to obtain enough harmonic energy to zero beat. A diode across the counter time base output test point will cause rich harmonics if enough drive cannot be obtained by other means.

Oscilloscope Comparison

This technique uses a dual trace oscil-

loscope to display the counter time base and compare it to the N. B. S. standard. It can be used to compare almost any standard time base to any of the N. B. S. services, even if the frequencies are different. For example the 5, 10, or 15 MHz WWV transmission can be directly compared to a 1 MHz time base.

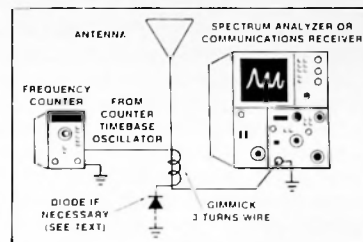

Fig. 39. Diagram Showing How to Calibrate a Frequency Counter with a Receiver

First connect the frequency counter time base oscillator to one input on a dual trace scope. The N. B. S. signal can be obtained from a specially built receiver, from a test point in the rf chain of some communications receivers, or from a transfer or crystal oscillator zero beat against WWV.

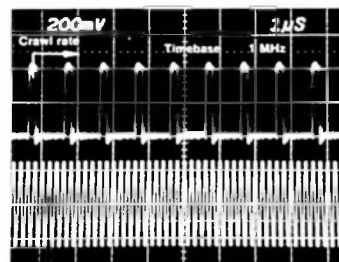

Fig. 40. Oscilloscope Comparison of 5 MHz WWV Against 1 MHz Time Base (figure 40). Adjust counter time base until 10^{-6} accuracy is achieved.

The oscilloscope time base should be triggered on the WWV standard. By using the $1\mu\text{s}/\text{div}$ sweep speed, movement of the counter time base display across the screen in more than one second is equivalent to 1×10^{-6} accuracy

B. Modulation and Deviation of the Carrier, Subcarrier and SCA

Modulation measurements are done with a modulation monitor. The monitor

is required to be in continuous operation (§73.268) and is used directly or indirectly to set all the other levels within the station. The FCC requirements are quite rigid for type approval of a modulation monitor, but with age, monitors eventually drift and require calibration.

The fm station must not exceed ± 75 kHz total deviation whether it is monaural or stereo (§73.268). When stereo is transmitted other standards also apply, however, the total deviation must still be ± 75 kHz. The stereo pilot must be held within 8 to 10% of the total envelope (§73.332 (b).). The SCA without stereo must not exceed 30%. With stereo, it must be limited to 10%. For a stereo station without an SCA, the pilot is normally set at 10% and each channel modulates the transmitter 45%. With an SCA plus stereo the pilot is 8 to 10%, each channel is 40%, and the SCA is 10%.

With all these different standards, it is necessary to calibrate the modulation monitor at many different points to insure accuracy when measuring all the channels and the pilot.

The spectrum analyzer can be used in three ways to verify the calibration of the modulation monitor. One technique uses the SPAN accuracy of the spectrum analyzer for quick checks while modulation is present. The other techniques use the mathematically exact Bessel Null principle to produce an indisputable calibration.

The Bessel Null Technique of Measuring Modulation

Fm modulation produces sideband frequency components, the amplitudes of which vary with modulation index and modulating frequency. The exact functions that occur are called the Bessel Null functions.

The Modulation Index is defined as the ratio of total \pm deviation of the carrier to peak modulating frequency:
 Modulation Index =

$$\frac{\text{Peak Deviation of Carrier}}{\text{Highest Modulating Frequency}}$$

At certain values of the Modulation Index, the carrier amplitude drops to zero (null) and all the energy is transmitted in the sidebands. The chart in figure 42 gives the modulation indices necessary to produce carrier nulls. By carefully choosing a modulation frequency and

	MAIN	SUB	PILOT	SCA
MONO	100%			
MONO-SCA	70%			30%
STEREO	45%	45%	8-10%	
STEREO-SCA	40%	40%	8-10%	10%

Fig. 41. Modulation Requirements for Different Station Configurations

NULL	MODULATION INDEX
1	2.4048
2	5.5201
3	8.6531
4	11.7915
5	14.9309
6	18.0711
7	21.2116
8	24.3525

Fig. 42. Bessel Null Chart

using the spectrum analyzer as an indicator, any modulation percentage can be generated and checked on the modulation monitor.

Procedure for Bessel Null Modulation Monitor Calibration

1. Connect the rf spectrum analyzer (such as a 7L12 or 7L13) to an rf test point in the output line of the transmitter and select a span of 20 kHz/div. Use the 10 dB/div, LOG mode.
2. Connect an audio generator to the input of the transmitter and bridge a frequency counter across the audio line. Frequency accuracy of the audio source determines the accuracy of the Bessel Null technique.
3. To check for 100% modulation calibration of the total fm signal, the optimum audio frequency must be selected. For the first null the frequency would be:

$$f = \frac{\text{Peak Deviation}}{\text{Modulation Index}} = \frac{75 \text{ kHz}}{2.4048}$$

The frequency would be 31.188 kHz. Since this is out of the audio passband

of the transmitter, we will check the 2nd null:

$$f = \frac{75 \text{ kHz}}{5.5201}$$

The frequency of the 2nd null would be 13.586 kHz. This is a good frequency that the transmitter will pass.

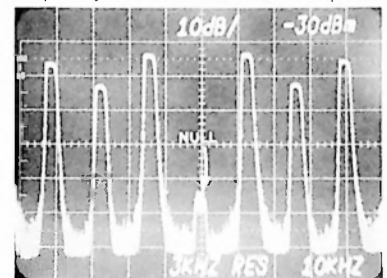

Fig. 43. Indication of the Second Null Using a Spectrum Analyzer

4. Use the frequency counter to set the audio generator frequency at exactly 13.586 kHz. Begin with the output amplitude set at zero and slowly increase the output level while watching the display on the spectrum analyzer screen. As the audio level is increased, the carrier will null. Continue increasing the audio output until a second null is reached. The second null indicates exactly 100% modulation of the transmitter which the modulation monitor should indicate at this point. Continue Bessel Null tests at other percentages of modulation to verify the lower ranges on the modulation monitor and to check the stereo pilot and SCA ranges on the monitor. Figure 44 shows the optimum frequencies and nulls for all standard fm percentages.

Percentage (%)	1	8	10	30	40	45	50	75	100
NULL	1	1	1	1	2	2	2	2	2
Frequency (Hz)	312	2,495	3,125	9,355	5,435	6,114	6,793	10,190	13,587

Fig. 44. Optimum Null Frequencies for Fm Stations

Using the Calibrated Span to Measure Modulation

The calibration span of the spectrum analyzer can be used to measure deviation of the fm carrier either with tones or with actual voice or music modulation. Accuracy depends upon the calibration

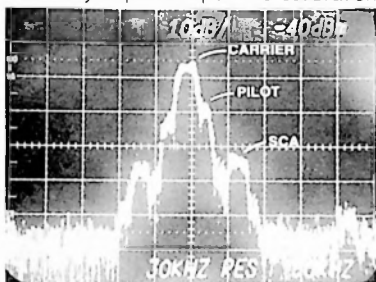

Fig. 45. Fm Stereo Station "Signature"

of the spectrum analyzer. The modern analyzer is quite accurate in this area once the operator becomes familiar with a few set-up procedures. By testing with actual music and voice audio, the spectrum display will quickly show a spurious out-of-band signal that sometimes occurs during complex modulation.

Procedure for Verifying Modulation Monitor Accuracy

1. Calibrate the horizontal span of the spectrum analyzer using the procedure in the owner's manual.
2. Connect the spectrum analyzer to an rf test point in the output line of the transmitter and select a span of 20 kHz/div and a vertical display of 10 dB/div.
3. With normal station audio the display for a stereo station will appear as in figure 45. On the average it will occupy an area ± 75 kHz around the carrier LESS the resolution bandwidth chosen.
4. Using single audio tones, the display can be expanded to show only half of the analyzer filter shape (figure 46).

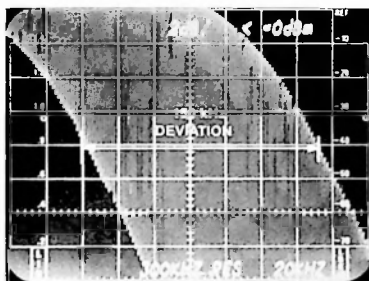

Fig. 46. Fm Deviation Measurement Using the Calibrated Span

With modulation applied, the horizontal width occupied by the modulation is the deviation directly displayed on the screen. All percentages of modulation can be checked in this manner.

Sideband Measurements Pilot and SCA Modulation

The pilot and SCA carriers must be set accurately to remain within compliance with FCC rules. Using a principle developed by Bessel, we can calculate the ratio between the fm carrier and the sideband produced by the 19 and 67 kHz carriers. The modulation index is low for these signals, hence they can be considered narrowband fm and will look similar to am on the rf spectrum analyzer.

For stereo stations, the pilot carrier will be set at 10% if the 19 kHz sideband is

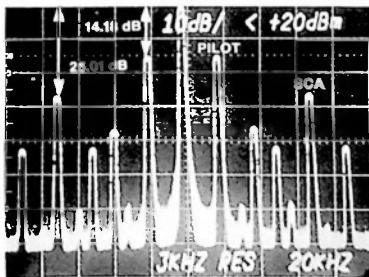

Fig. 47. Pilot and SCA Measurement Using the Bessel Null Method

13.76 dB below the carrier. If an SCA is used with stereo, the SCA will be down

25.01 dB at 10% modulation and the stereo pilot will be down 14.18 dB. This is demonstrated in figure 47.

For a monaural station, 30% modulation of the SCA is permitted. The 67 kHz sideband will be 15.35 dB below the carrier.

C. Antenna Pattern

The pattern or coverage area of an fm station is carefully checked when it begins service. As the years go by measurements must be made to determine if the performance of the antenna is changing. By using a high-frequency spectrum analyzer and a dipole antenna that you can construct with readily available materials, patterns can be verified without an expensive field strength measurement. While the accuracy is quite high and repeatable, we do not recommend these tests as absolute measurements for licensing unless other calibration steps are also taken.

Procedure for Pattern and Field Strength Measurements

A dipole antenna can be constructed with standard 300 ohm twin lead (flat line) cut to the length shown in figure 48. The 300 to 75 ohm balun is available through most CATV supply houses. For maximum sensitivity, a preamplifier should be used. The TEKTRONIX 7K11 or AM 511 are both available and match the 75 ohm antenna impedance. To insure maximum accuracy and minimize reflections, it is recommended that a 10 dB pad be used between the dipole antenna and the amplifier input.

To measure field strengths with the 7L12/7K11 or similar combination, take spectrum analyzer readings in the field, orienting the dipole for maximum output. Measure the carrier power in dBmV, add an antenna correction factor of 8 dB for the homemade dipole, add the 10 dB pad value if used, then convert to μ V/meter using the chart in figure 49.

D. Spurious Signals and Harmonics

Spurious signals and harmonic measurements are necessary to insure that there are no emissions from a transmitter that might potentially interfere with another radio service or channel. Spurious signals can originate either within the transmitter, or at the antenna. The most logical place to test is at some distance from the transmission site since it

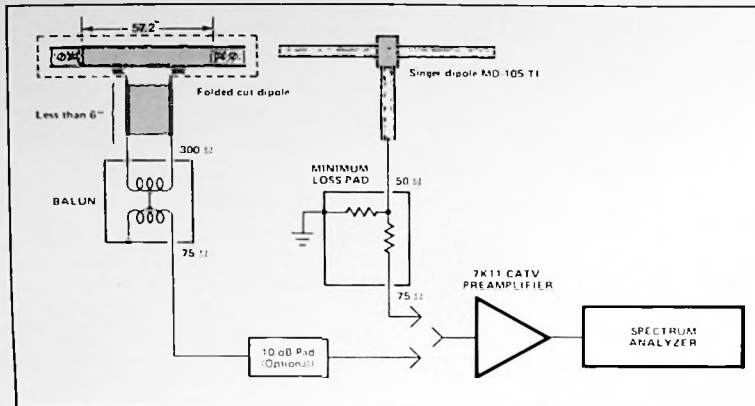

Fig. 48. Details on the construction of a Test Dipole for Fm Stations

CONVERSION TABLE dBmV – Microvolt/m									
Reference Level: 0 dBmV = 1 millivolt/m									
dBmV	$\mu\text{v/m}$	dBmV	$\mu\text{v/m}$	dBmV	$\mu\text{v/m}$	dBmV	$\mu\text{v/m}$	dBmV	$\mu\text{v/m}$
40	10.00	20	100.0	0	1.000	21	11.220	41	112.200
39	11.22	19	112.2	1	1.122	22	12.590	42	125.900
38	12.59	18	125.9	2	1.259	23	14.130	43	141.300
37	14.13	17	141.3	3	1.413	24	15.850	44	158.500
36	15.85	16	158.5	4	1.585	25	17.780	45	177.800
35	17.78	15	177.8	5	1.778	26	19.950	46	199.500
34	19.95	14	199.5	6	1.995	27	22.390	47	223.900
33	22.39	13	223.9	7	2.239	28	25.120	48	251.200
32	25.12	12	251.2	8	2.512	29	28.180	49	281.800
31	28.18	11	281.8	9	2.818	30	31.620	50	316.200
30	31.62	10	316.2	10	3.162	31	35.480	51	354.800
29	35.48	9	354.8	11	3.548	32	39.810	52	398.100
28	39.81	8	398.1	12	3.981	33	44.670	53	446.700
27	44.67	7	446.7	13	4.467	34	50.120	54	501.200
26	50.12	6	501.2	14	5.012	35	56.230	55	562.300
25	56.23	5	562.3	15	5.623	36	63.100	56	631.000
24	63.10	4	631.0	16	6.310	37	70.790	57	707.900
23	70.79	3	707.9	17	7.079	38	79.430	58	794.300
22	79.43	2	794.3	18	7.943	39	89.130	59	891.300
21	89.13	1	891.3	19	8.913	40	100.000	60	1 000.000
				20	10.000				

Fig. 49. $\mu\text{V}/\text{Meter}$ from dBmV Chart

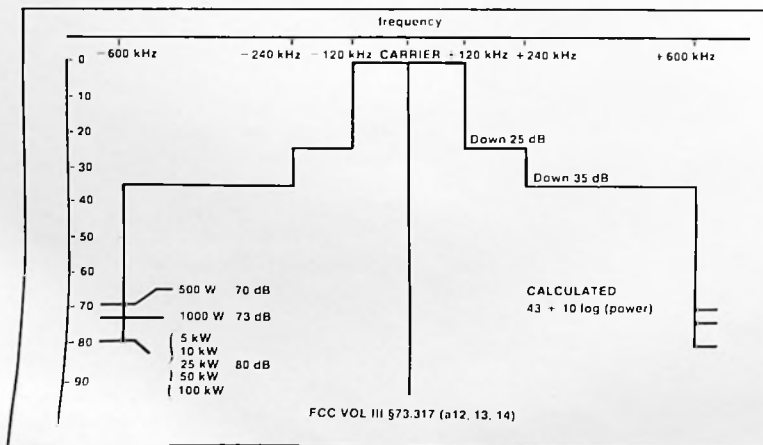

Fig. 50. Summary of FCC Rules on Spurious Emissions

is more important to measure what is being radiated than what occurs in the transmission line. Begin testing for spurious signals with the test dipole one mile or more from the transmitter. Then, if a problem is noted, the interfering signal can be traced back through the transmitting chain and pinpointed.

The FCC specifications for spurious signals are summarized in figure 50. Note that there are actually three requirements: in and out-of-band spurious, spurious due to modulation, and harmonics of the carrier.

Procedure for Measuring Spurious Signals

1. Use the spectrum analyzer and the test dipole (constructed as shown in the preceding chapter) at some distance from the transmitter. With an unmodulated carrier, check for any spurious signals located close to the carrier. If any are noted, momentarily remove the plate power from the transmitter and see if they remain.
2. Test for out-of-band spurious signals by checking across the fm band while turning the plates of the transmitter 'off' and 'on'. Any signals that occur only while the plates are 'on' should be suspect.
3. Modulate the transmitter and check to see that the transmitted envelope conforms to the chart in figure 50. Some engineers like to use a storage display on the spectrum analyzer to perform this test.
4. Check for harmonics of the transmitter by checking the predictable harmonic positions (2nd, 3rd, etc.) as shown in figure 52.

IV. Day-to-Day Maintenance

While the yearly proof of performance and calibrations are important, the day-to-day maintenance takes up most of a radio engineer's time. The typical engineer always seems to have a long list of things to do and would often like to do more on a particular project or repair but just does not have time. The spectrum analyzer has much to offer both in the area of new tests, and in the area of time saving techniques for checking-out consoles, cart machines, and other audio and processing equipment. The key is to use an audio spectrum analyzer such as the 5L4N which permits rapid frequency

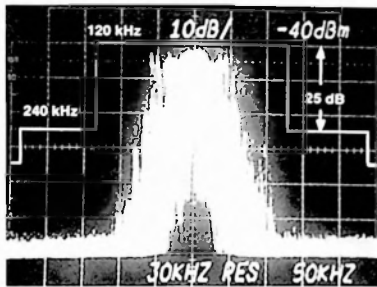

Fig. 51. Occupied Bandwidth Test

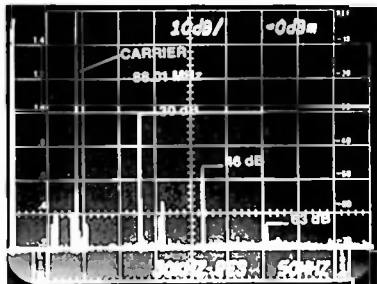

Fig. 52. Checking Harmonics of the Carrier response, noise, and distortion checks.

A. Console Checks

This is a test procedure that checks the response, distortion, and noise on each input and channel of an audio console. By using the switch and jumper arrangement shown in figure 53, it is possible to test each input quite rapidly.

1. Connect the left channel program line OUT on the console through a matching pad to the input of the 5L4N Spectrum Analyzer.
2. Connect the switch harness (alligator clips are recommended) to the first input (left channel) on the console and select a level that does not overdrive the console as indicated by the console **vu** meter.
3. Use the 5L4N Tracking Generator to sweep the console from 20 Hz to 20 kHz.
4. Switch the SG 502 Audio Oscillator and drive the console to 0 **vu** using a 1000 Hz tone.
5. Check the harmonic distortion using the technique and charts on page 00. Both the combination of low audio oscillator output with the console pot set to $\frac{3}{4}$, and high oscillator output with the console pot set to $\frac{1}{4}$, should indicate 0 **vu**.

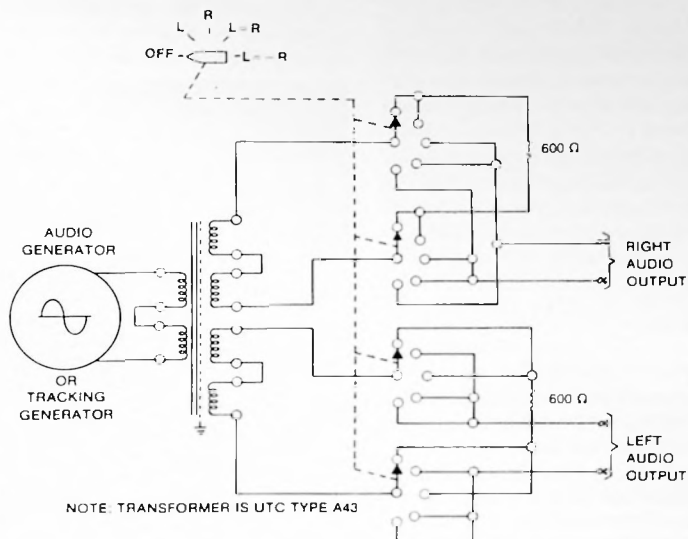

Fig. 53. Jumper Arrangement for Testing Stereo Consoles

6. To check the low level harmonic distortion, set the console pot to $\frac{1}{2}$, and turn down the audio oscillator output until the **vu** meter on the console indicates -13 dBm.
7. Switch off the audio oscillator and read the residual noise and hum for that channel of the console using the procedure on page 10 of this booklet.
8. Continue response, harmonic distortion, and noise tests on all inputs of the console.
9. Switch the oscillator and the spectrum analyzer to the right channel. Repeat response, distortion, and noise tests on all right channel inputs on the console.
10. To check the console separation, sweep the left channel while the spectrum analyzer input is connected to the right channel output. A display such as shown in figure 54 may be obtained. The difference between the normal response of the right channel and the leakage response is the separation and may be read directly in dB. Repeat the separation test from the right to the left channel.
11. Other console tests such as inter-modulation distortion and transient

distortion may be performed at this time. Other Tektronix application notes on audio and **am** radio measurements contain procedures for these additional tests.

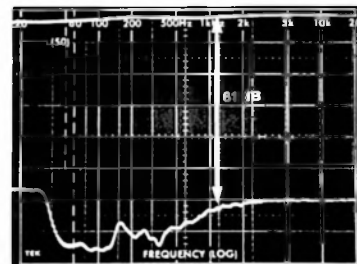

Fig. 54. Measuring Console Separation

B. Studio Transmitter Link Test

Many **fm** stations now employ an **stl** between the studio and the transmitter. These are licensed to operate in the 942 to 951.5 MHz bands (although the size of the band has now been cut so that no new licenses will be issued in the 942 to 947 MHz band).

A stereo station can send the audio as two separate channels, or it can send the composite envelope on *one carrier*. Because the **stl** uses frequency modulation and the channels allocated for **stl** use are 500 kHz wide, there is ample room for a quality transmission of the

signal in composite form to the transmitter site. Many stations prefer composite transmission since the stereo generator can then be located at the studio avoiding many problems affecting phase and separation.

Few stations have any way of testing the **stl** other than to check the manufacturer's recommended voltages and hope the transmitter holds together. The high-frequency and audio frequency spectrum analyzers can be used to check further to insure the utmost performance.

Checking a Composite Stl

Use the **rf** spectrum analyzer to look at the carrier. Using 20 kHz/div, the composite **stl** will look similar to an **fm** stereo station. Check the deviation to verify that it is correct. The **stl** uses the same pre-emphasis as the **fm** station so that all checks covered earlier in this booklet can be used.

The composite **stl** should be capable of passing a wideband signal. This can be verified by sweeping the transmitter with an oscillator from 0 to 100 kHz. An audio spectrum analyzer with storage can be used at the receiver to obtain results such as those shown in *figure 55*. Response should be flat over the composite **stl** since the pre-emphasis occurs in the stereo generator. Other tests such as distortion and noise should also be checked. Distortion checks including intermodulation tests are extremely important in maintaining good crosstalk and separation in the composite **stl**. The output of the composite **stl** is fed directly to the **fm** exciter with no further modifications, so it is imperative that the composite **stl** perform correctly.

Checking Single Channel Stl's

If a station uses two separate **stl**'s for the left and right channels then each channel is treated as a separate path. The transmitters are generally licensed within the same 500 kHz channel, staggered around the middle of the channel. Each transmitter uses the same pre-emphasis as an **fm** transmitter. At the transmitting antenna, two transmitters will appear similar to *figure 56*. It is important to "look at" both transmitters simultaneously, and verify that both have about the same power and deviation as is indicated on the analyzer.

At the receive site, generally both receivers are fed from the same receive antenna. The spectrum analyzer should

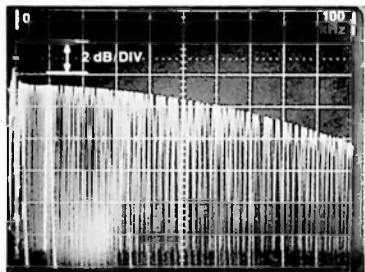

Fig. 55. Composite Stl Response

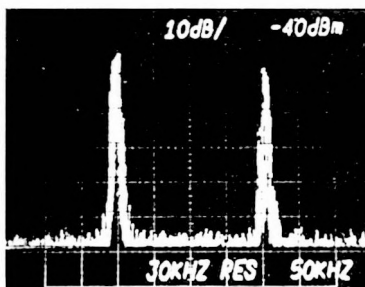

Fig. 56. Dual Stl Transmitters

be used on the receiver coax to verify that both carriers are received with equal strength. Problems at this point involve the signal path. The transmit and receive dishes can be aligned using the spectrum analyzer as an indicator, if desired.

Once the path and transmitter performance is verified, the audio spectrum analyzer can be used to verify the response and distortion of the **stl**'s. Use an audio oscillator with a slow sweep at the transmitter input and the audio analyzer at the receiver. By using storage and a slow audio sweep, the response and pre-emphasis can be checked. Use single audio tones to test the harmonic distortion and remove all input signals to check noise. Most stations using two **stl**'s use the pre-emphasized signal directly, bypassing the pre-emphasis circuits in the stereo generator. It is still important to verify the phase of each channel relative to the other for maximum separation. The phase can be checked with an oscilloscope and the separation between channels can be checked by sweeping one **stl**, and using the low frequency analyzer on the other channel to note any leakage.

C. Intermodulation Testing of Audio Equipment

Intermodulation testing is another method of checking the distortion of an audio system or transmitter. Many audio authorities feel that there is a much higher correlation between **im** test results and listening tests than with harmonic distortion. Since all broadcasters are in the music business, the **im** test is a valuable addition to other forms of testing.

The low-frequency audio spectrum analyzer can be used directly to measure both harmonic and intermodulation distortion.

Fm Stereo Transmitters

It is critical that **fm** stereo systems and transmitters have good **im** performance since this is vital to a clean sound and contributes to the separation and crosstalk.

The following procedures cover two methods of measuring intermodulation, the SMPTE and the CCIF techniques. The exact tones and parameters are shown in *figure 57*. These tests can be performed on any portion of the audio chain. In addition, a specialized technique is shown to verify the **im** distortion of the transmitter after the stereo generator. This last procedure is invaluable when attempting to solve transmitter crosstalk and separation problems.

Procedure for Intermodulation Distortion Tests

1. Set up a two tone source connected to one channel of the studio console using the equipment shown in *figure 58*.
2. Set the tone ratios. If the SMPTE method is used, the 60 Hz tone should be 4 times (12 dB) greater than the 7 kHz tone. If the CCIF technique is used, the two tones (6 and 7 kHz) should be equal in amplitude.
3. The console level should be increased until 100% (45% for a stereo channel) modulation is indicated on the modulation monitor.
4. The 5L4N should be connected to the modulation monitor output and set for a span of 0 to 20 kHz (2 kHz/div).
5. SMPTE distortion is measured by noting the dB down of the 60 Hz sidebands around the 6 kHz tone as

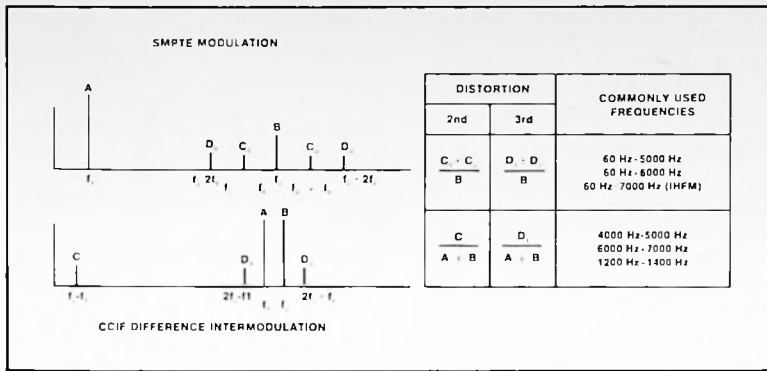

Fig. 57. SMPTE and CCIF Intermodulation Test Standards

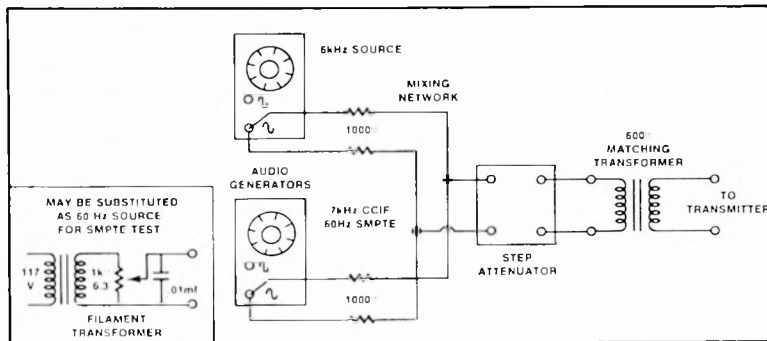

Fig. 58. Two-tone Source for Intermodulation Tests

shown in figure 59, then converting to percentage using the chart in figure 23.

- Intermodulation distortion using the CCIF method is performed by noting the dB down of the generated 1 kHz sidebands as shown in figure 60, then converting to percentage. The single carrier at 1 kHz is the 2nd order difference beat and the sidebands centered around the 6 and 7 kHz tones are the 3rd order components.

D. Intermodulation Testing of the Transmitter/Generator Combination

Some specialized tests have been devised to evaluate the im performance of the fm transmitter and the stereo generator. The ability of the stereo generator to produce clean modulation components without intermodulation is only one requirement. The bandpass of the transmitter and the linearity of the modulation oscillator both contribute to the im performance. Typically most stereo systems will pass signals with in-

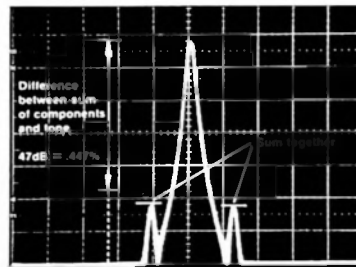

Fig. 59. Measurement Using the SMPTE Standard

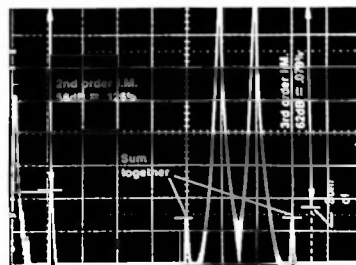

Fig. 60. Measurement Using the CCIF Standard

termodulation down at least 40 dB. A few companies now offer systems with intermods suppressed at least 60 dB.

One of the simplest ways to evaluate intermod performance is to use three test combinations of a 7 kHz tone. The 7 kHz modulates the transmitter through the stereo generator as a *left* only, then a *left plus right* and finally as a *left minus right* signal. A variation of this test is to use a 60 Hz and 7 kHz tone in combination, with the 60 Hz 12 dB greater than the 7 kHz. Many intermod products will be formed that correspond to second and third order components. If linearity adjustments are provided in the modulation oscillator, adjustments will sometimes improve the performance. Retuning the transmitter can also improve performance. As part of the intermod test, the components in the 67 kHz SCA area should be noted since they will determine the crosstalk performance. In some transmitters, intermods should be measured out to 500 kHz since many transmitters will pass higher frequency intermods, causing the occupied bandwidth to be out of tolerance.

Figures 61 through 64 show a typical transmitter intermod test sequence.

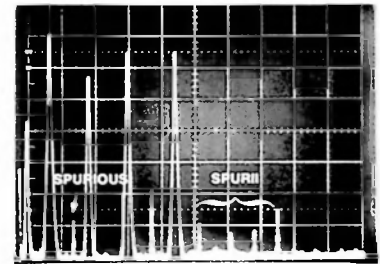

Fig. 61. 7 kHz Left Channel Im Test

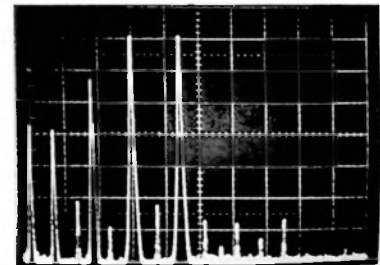

Fig. 62. 7 kHz L Minus R Im Test

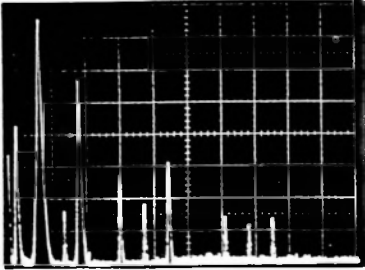

Fig. 63. 7 kHz L Plus RA Im Test

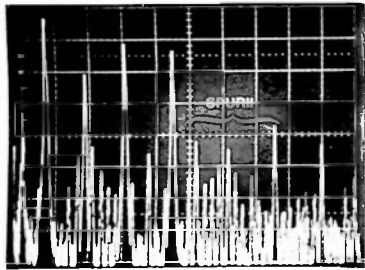

Fig. 64. Im Test Indicating Modulation Oscillator Non-linearity

E. Crosstalk Measurements Using Program Material

Crosstalk measurements with tones or sweeping signals provide numerical data as to the performance of a stereo system. In the end, however, the system will be used to pass music and voice programming. Therefore one of the most effective tests is to use actual program material and store the results until a complete display of the performance can be observed. Often uncorrelated products will be generated that a tone test does not uncover.

Figure 65 is an example of a program test. The level of the pilot carrier was reduced so that the action of the lowpass filters could be evaluated. Note that the

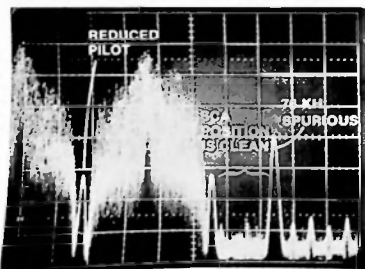

Fig. 65. Composite Output with Program Material and Reduced Pilot Carrier

67 kHz position is relatively clean and free from spurious components. Figure 66 is an example of a program test on the SCA channel. Note that the products are reduced 60 dB below 53 kHz.

F. Pilot Interference

High quality stereo performance requires that the pilot carrier be received without interference by the receiver. If the filtering or intermod performance of the transmitter is poor, then the pilot frequency may have interfering information present.

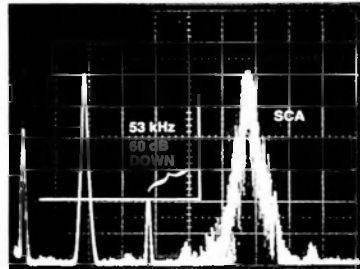

Fig. 66. SCA Crosstalk Using Program Material

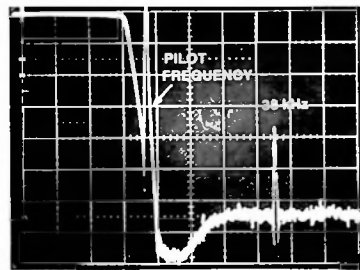

Fig. 67. Sweep of Low-pass Filter Showing Rejection at Pilot Frequency

Two tests should be performed. The lowpass filter (generally 17 kHz) should be carefully swept to insure that audio is suppressed at least 40 dB below 100% modulation at 19 kHz. Another valuable test is to remove the pilot carrier and check the 19 kHz position while program material modulates the transmitter. Figure 65 is an example of good pilot carrier protection.

G. Dolby Fm

Application of the Dolby type B system to fm broadcasting is becoming more common today now that commercial receivers contain circuits to use the noise reduction characteristic of the transmissions. The total benefit of 9 dB of noise reduction can be obtained in a properly set up system.

To use the Dolby system in an fm station, the normal pre-emphasis curve is changed to 25 μ s. Then the Dolby B unit is added. More high-frequency program content can be transmitted without overmodulating. In addition, the Dolby B unit boosts the high frequency content of quieter passages. The net effect is that the system is compatible with existing receivers, and receivers with Dolby circuits will have a better apparent noise performance.

Verifying Dolby Performance

1. The 25 μ s pre-emphasis circuit should be checked for proper response using response procedures on page 6 of this booklet. The graph in figure 69 should be used for the 25 μ s plot.
2. The tracking generator output of the audio spectrum analyzer should be connected through a 600 ohm step attenuator to an input on the audio console. Bypass all limiters and modulation processors.
3. Connect the audio spectrum analyzer to the modulation monitor output. Sweep the transmitter at 100% modulation. Repeat the sweep with 10 dB of attenuation inserted. Continue sweeping in 10 dB increments. A display similar to figure 68 will indicate proper operation of the Dolby B encoder.

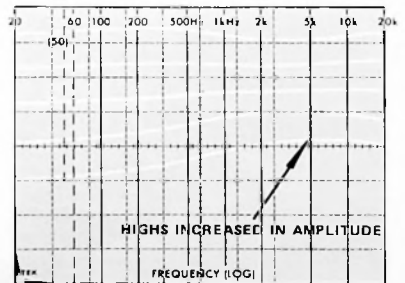

Fig. 68. Dolby 'B' Encoder Characteristic Response

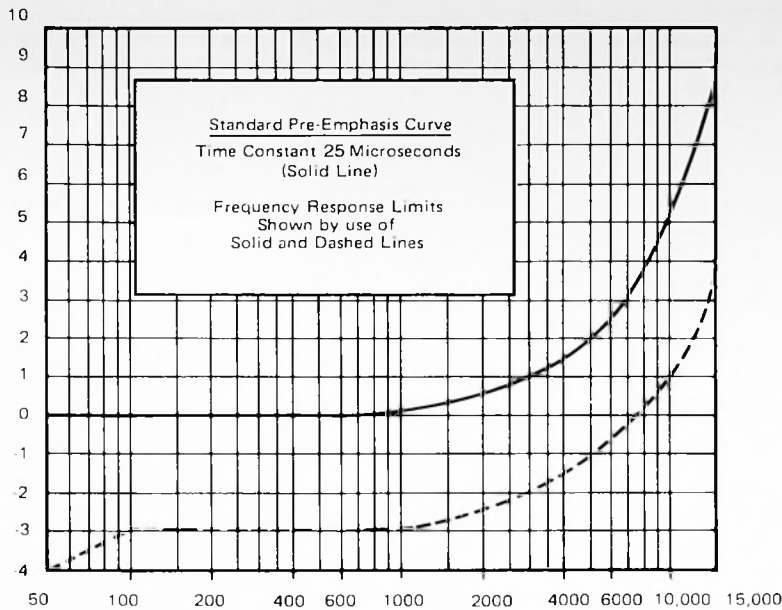

Fig. 69. 25 μ s Pre-emphasis Curve Used with Dolby Fm

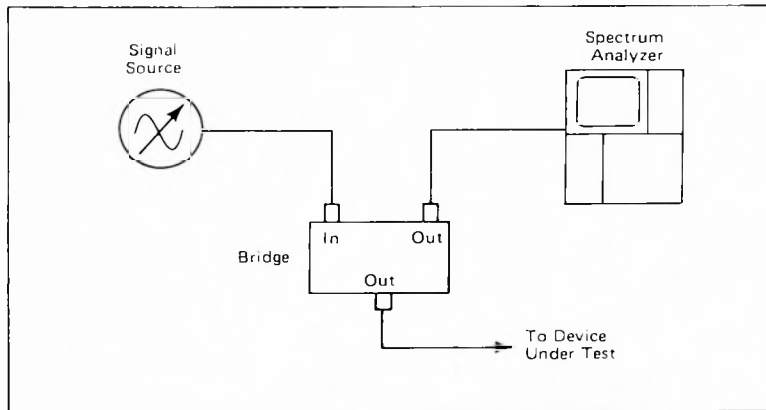

Fig. 70. Bridge Connections to Test Vswr

H. Antenna, Filter and Feedline

Components of the transmitter system must sometimes be tested out of service to isolate problems or verify performance. If a signal source such as a sweep, CW, or tracking generator (TR 501/502 or SW 503) is available, the performance of most filters, transmission lines, and couplers can be checked. The spectrum analyzer is used in the storage mode (or with a camera if storage is not available) to check the response and insertion loss. With the addition of a bridge, return loss (match), and tuning can also be checked on single port devices such as the transmitter output stage, or the antenna and feedline (figure 70). The inverse of the return loss display of an antenna gives the tuning characteristic (figure 71).

CAUTION: Do not attempt to make measurements on the feedline either while the transmitter is energized, or in the presence of high ambient field from other local transmitters since the induced voltages can cause damage to the measuring equipment.

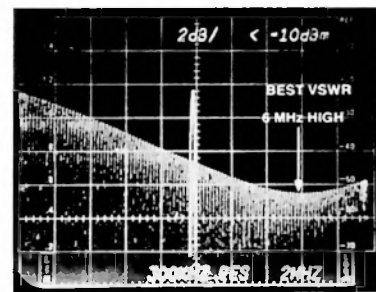

Fig. 71. Tuning of an Fm Antenna. Note that the Antenna is Tuned Incorrectly with Minimum VSWR Approximately 6 MHz Above Carrier

FOOTNOTES

1. "F.C.C. Rules and Regulations Volume III," September 1972, Part 73, Update #6/75.
2. "FM Proof of Performance Manual," December 1974, *Broadcasting Magazine*, 1014 Wyandotte Street, Kansas City, MO 64105.
3. "The F.C.C. Gives Perspective to Proof Requirements," Dennis Ciapura, *Broadcast Engineering*, Page 21, June 1973.
4. "AM-FM Broadcast Maintenance," Harold E. Ennes, Howard W. Sams and Co., ©1968.
5. "Spectrum Analysis... Noise Measurement," 150-4 January 1973, *Hewlett Packard*.
6. "Spurious Emission Measurements," James R. Stephenson Jr., *Broadcast Engineering*, Page 38, July 1972.
7. "Reference Data for Radio Engineers," Fifth Edition, Howard W. Sams and Co., ©1968.
8. "Adding IM Tests to Your Audio Proof," Dennis Ciapura, *Broadcast Engineering*, Page 32, January 1973.
9. "An Analysis of the Intermodulation Method of Distortion Measurements," W.J. Warren and W.R. Hewlett, *Proc. IRE*, Volume 36, Page 456, February 1948.
10. "FM Stereo Proof of Performance," Steve Broomell, Gates Radio, Quincy, IL 62301.
11. "Optimum Use of Noise Reduction in FM Broadcasting," Ray Dolby, *Journal of the AES*, Page 357, June 1973.
12. "Let's Minimize Those FM Transmitter Problems," Glen Clark, *Broadcast Engineering*, Page 34, Feb. 1974.
13. "New Techniques for Generation of Composite Stereo Signals," David L. Hershberger and Geoffrey N. Mendenhall, Harris Corp., Quincy, Ill.

Additional measurements are described in these Tektronix publications: AM Broadcast Measurements Using the Spectrum Analyzer, Television Operational Measurements Video and RF for NTSC Systems, and the Tektronix Cookbook of Standard Audio Tests.

INTERNATIONAL FIELD OFFICES, DISTRIBUTORS AND REPRESENTATIVES

- ALGERIA**
Measurlec
111 Bd Sahlin Boulevard
Algeria
Phone: 9245 70 and 60 45 71
Telex: 319700 (Telex not available)
Risks
Cable: IREINDISS (Algeria)
- ARGENTINA**
Cosmos S.A.
Calle de Prm 4071
Buenos Aires
Phone: 52 5186 51 1031
Telex: 012 2204
Cable: COSAR, Buenos Aires
25 de Mayo P. 1930
Cordoba
Phone: 51 2037
- AUSTRALIA**
Tektronix Australia Pty Limited
80 Waterloo Road
Nasim Road, N.S.W. 2113
Sydney
Phone: 886 7006
Telex: A2212021
Cable: TEKTRONIX Australia
132 Giles Street
Adelaide, South Australia 5000
Phone: 243 2811
214 Avon Road
Hawthorn Vic 3122
Melbourne
Phone: 41 0594
- AUSTRIA**
Rohde & Schwarz - Tektronix
Ges m b H
Sonne im Bismarck 20
A-1184 Wien
Phone: 107924-11-11
Telex: 107924-11-11
- BELGIUM**
Tektronix nv/sa
Av. J. Cassin 13412
Bruxelles 1150
Phone: 62221518-48
Telex: 26713
Cable: TEABELL
- BRAZIL**
Impulhaco
Industria e Comercio
Ambrósia S.A.
Rio de Janeiro 108 - 2. andar
Rio de Janeiro RJ
Phone: 204 7501, 205 7920, 206 0061
Telex: 331 21213
Cable: RAOGOCARCO, Rio de Janeiro
Rio de Janeiro RJ
Sao Paulo SP
Phone: 61 2610, 66 0912, 66 6016
Fax: 66 1871
- CANADA**
Tektronix Canada Ltd
81 Main Street
Barré, Ontario
L3M 5K3
Canada
Phone: 705 737 2700
Telex: 109 01186Z
Cable: TEKANARNA
- FIELD OFFICES**
(Montreal)
100 St-Jacques Street
Pointe-Claire, Quebec
H3T 2Y3
Phone: 514 697 5380
Telex: 109 01186Z
Cable: TEKANARNA
- Calgary Alberta**
820 10th Avenue S.W.
Calgary Alberta
T2P 1G9
Phone: 403 204 4134
Telex: 109 01186Z
Cable: TEKANARNA
- Edmonton Alberta**
453 2nd
Edmonton Alberta
T6C 2B5
Phone: 403 434 4166
Telex: 109 01186Z
Cable: TEKANARNA
- Ottawa Ontario**
1782 Deschamps (Drummond)
Ottawa Ontario
K2C 2B5
Phone: 461 225 2840
Telex: 053 1119
Cable: TEKANARNA
- (Vancouver)**
8515 Canada Way
Burnaby B.C.
V3G 4K1
Phone: 604 438 4321
Telex: 083 5400Z
- (Toronto)**
P.O. Box 4680
Toronto Ontario
M3J 1K4
Phone: 705 737 2700
Telex: 109 01186Z
Cable: TEKANARNA
- Hong Kong**
HONG KONG
1782 Deschamps (Drummond)
Ottawa Ontario
K2C 2B5
Phone: 461 225 2840
Telex: 053 1119
Cable: TEKANARNA
- INDIA**
Hindion Services Private Ltd
6 A-1, Jagannand Marg
Bombay 400 064
Phone: 36531
Telex: 9510 - 2126
Cable: TEHNDI Bombay
817 Raj Mahal West Extension
Bangalore 560 006
Phone: 33339
Telex: 96124 231
Cable: TEHNDI Bangalore
- INDONESIA**
C.V. Dwi Tunggal Djaja
Jl. Rong Ai No. 9
Jakarta
Phone: 6689
Cable: CVOHWIDJAJA
- IRAN**
Irantronix Company Ltd
20 Sium Road
Roshan Ali Avenue
Tehran
Phone: 82994 & 831564
Telex: 217950 BIRAK IR
Cable: IREHNDXAV Tehran
- ISRAEL**
Estronics Ltd
11 Binyan Street
Tel-Aviv
P.O. Box 19300
Tel-Aviv
Phone: 475151
Telex: 031 638
Cable: ESTRONIX Tel-Aviv
- JAPAN**
Sony/Tektronix Corporation
9-31, Kitashinjyua 5, Shinjyua Ku
Tokyo 161
P.O. Box 114, Nanda 2-chome
Tel-Aviv
Phone: 485 0221 (Japan Office)
Telex: 223 228
Cable: SONYTEX Tokyo
c/o Tokyo Ebu Building 1-6-11
Tokyo 100
Phone: 170 0141 (Japan Office)
c/o Takushoku Building 2-2-1
Chiyoda-ku
Osaka-shi
530
Phone: 312 2751 (Japan Office)
Tokyo 100
Telex: 223 228
Cable: SONYTEX Tokyo
- JORDAN**
TAREO Scientific Bureau
Sah Road
P.O. Box 1463
Amman
Phone: 9655 & 3285
Telex: 1611 ADEL JO
Cable: ADELREJG AMMAN
- KUWAIT**
TAREO Company
P.O. Box 2056
Phone: 43404 & 33045
Telex: 20401E 2015 W
Cable: TAREO KUWAIT
- LEBANON**
Projets S.A.L
Beyrouth
Phone: 251680
Telex: 20666
Cable: PROJETS BEIRUT
- MALAYSIA**
Mecomb Malaysia Sdn Bhd
No. 2, Lorong 13-A
Petaling Jaya, Selangor
Phone: 773455
Telex: 3706S
Cable: MECOMB Petaling Jaya
- MEXICO**
Técnicos Argotal, S.A.
Depto. Control de Calidad
Av. de los Arcos 160
Apdo. Postal No. 251 - México D.F.
México D.F.
Phone: 545 85 00
Telex: 5117 25
Cable: ARGOTELA México
Av. Universidad 1335 Norte
Monterrey NL
Phone: 41 13 60
Telex: 018A5
Cable: 1256562 GATE 383
Guadaluajara Jalisco
Phone: 77 26 36 17 78 12
Telex: 0688 9710
- MOROCCO**
SCRCM
29 BD Grand
Casablanca
Phone: 21 5 11
Telex: 21875
Cable: SCRCM CAS 12 1815
- NEW ZEALAND**
W & K McLean Ltd
101 105 Felton Marina Avenue
Glen Innes
P.O. Box 3597
Auckland 6
Phone: 187 017
Telex: NZ267A OSH V
Cable: NKSTV Auckland
181 Wain Street
Wellington
Phone: 851 150
Telex: NZ2653 OSH V
2nd Floor, Museum Building
210 Oxford Terrace
Wellington
Phone: 324231
Christchurch
Phone: 64 403
- NIGERIA**
Motat Engineering Co. Ltd
P.O. Box 6209
85 Wapiti Street
Lagos
Phone: 43195
Telex: 21935 OJNING
Cable: MOIATENG LAGOS
S.W. 31 Jebu Road
Lagos
P.O. Box 3464
Ibadan
Phone: 22824
- NORWAY**
Morgensierne & Co AS
Kjøpmannsgt 23
P.O. Box 4686, Rodevika, Oslo 51
Oslo
Phone: 3561 10
Telex: 11719
Cable: MOROI Oslo
- PAKISTAN**
Pak Land Corporation
Centre Commercial Area
Ajlmal Road
P.E.C.H. Society
Karachi-27
Phone: 432814, 43642
Cable: PAKLAND Karachi
- PANAMA**
Executive Marketing Corporation
Arados 4729
Panama 5
Phone: 64 9354 64 9651
Telex: 228 222
Cable: MASPENSU PA Panama
- PERU**
Importaciones y
Representaciones
Electronicas S.A.
(IRE Ingremicos)
Av. La Fragua D. B. 2201 - 105
El Barrio Roma
Lima
Phone: 28 86 50
Telex: 22607
Cable: IRE ING PERU Lima
- PHILIPPINES**
Philippine Electronic
Industries Inc
3rd Floor, RCA Circuit Bldg
8250 Power Road
P.O. Box 408, Makati Commercial
Center
Makati Rizal 1317
Phone: 87 99 26, 87 99 27, 87 99 28
Telex: 222206
Cable: PHILECTRON Makati
- PORTUGAL**
Equipamentos de
Laboratório Lda
Estrada 1014, Santa Adelaide
P.O. Box 1100 (Cidade Jardim)
Lisbon
Phone: 97 65 51
Telex: 12702 EGULAL
Cable: EQUIB LISBOA
- REPUBLIC OF SOUTH AFRICA**
Protea Physical & Nuclear
Instrumentation (Pty.) Ltd
P.O. Box 31127
Brunner 2018
746 9th Street
Wynnton 5141
Transvaal
Phone: 786 1020
Telex: 242487
P.O. Box 141
Durbanville 7202
224 2nd Street
Pretoria 2001 (Old Brunton)
Phone: 51 247
Telex: 5 77531
P.O. Box 47031
Greenwood 2025
116 2nd Street
Durban
Phone: 35 1100
Telex: 6 2775
- SAUDI ARABIA**
Electronic Equipment Marketing
Establishment
P.O. Box 3750
Riyadh
Phone: 32700 32761
Telex: 20120
- SINGAPORE**
Mechanical & Combustion
Engineering Co. Pte. Ltd
10 12 Tiam Street
P.O. Box 45, Alexandra Road (Raffles
Singapore)
Phone: 642151
Telex: 80128
Cable: MECOMB Singapore
- SOUTH KOREA**
M-C International (Korea) Ltd
Room 1407, Center Building
9-1 Songdo-dong, Songdo-gu
P.O. Box 11551
Seoul
Phone: 24 4015
Cable: EVNCEKREA Seoul
- SPAIN**
C.R. Mares, S.A.
Valencia 331
Barcelona 16
Phone: 231 62 00
Telex: 21332
Cable: MARES Barcelona
Getxo 66
Madrid
Phone: 413 13 00
Telex: 7332
Cable: MARS Madrid
- SRI LANKA**
Electronic Roche Limited
C.O.P.O. Box 4
Colombo
Phone: 3356, 2947, 2764
Cable: LAKARPANA Colombo
- SUDAN**
Cine & Photo Supply
Company (CIPSC)
P.O. Box 393
Khartoum
Phone: 2162, 2033 and 4248
Telex: M3 PHOTON A
Cable: PHOTON A
- SURINAME**
Wong Sang Isoi & Co.
P.O. Box 163
Paramaribo
Phone: 73111 2517, 1254 7610
Cable: SANGISOLO Paramaribo
- SWEDEN**
Tektronix AB
Fax
S-171 (4 Solna)
Phone: 04810081
Telex: 17511 TEKVA S
Cable: TEKTRONIK Stockholm
Kommunikations-
S 414 Sö Gården
Phone: 43 12 10 35
- SWITZERLAND**
Tektronix International A G
P.O. Box 91
CH-4001 Zug
Phone: 042 29 91 92
Telex: 78668
Cable: TEKTRITAG
- SYRIA**
General Trading Company
P.O. Box 104
Damascus
Phone: 81007 22470 559103
Telex: 1123 YGICOO SY
- TAIWAN**
Height Trading Co. Ltd
Importing Fairchild Section 4
616 Box 46-03
Taipei 114
Phone: 251 0910
Telex: 21427
Cable: HEIGHT Trading Taipei
- THAILAND**
G Simon Radio Company Ltd
30 Ratchadapisek Avenue
Bangkok
Phone: 3099 3
Cable: SIMRACO Bangkok
- THE NETHERLANDS**
Tektronix Holland N.V.
Mediolanweg 2
Postbus 164
Breda 2000
Phone: 060-406153
Telex: 16149
- TURKEY**
Erkmen Elektronik Ateier
Ticaret Anonim Sektör
Nispetiye Caddesi 132
Carmali, Istanbul
Phone: 41 14 04 31 34
Telex: 23351 MAG TR
Cable: IREKMER TUR
- TUNISIA**
EL ESLEK
Societe Industrielle et
Commerciale d'Equipe-
ments Electroniques
3 Rue de Venise
Tunis
Phone: 24187
Telex: 10612 ESELE TN
- UNITED ARAB EMIRATES**
Contact TAREO COMPANY KUWAIT
- UNITED KINGDOM**
Tektronix K Limited
Barnhill House
10 Seacombe Road
P.O. Box 40
Harpenden
Phone: 0464 63144, 61251
Telex: 21645
Cable: TEKTRON K Harpenden
181A Maidenhead
Barnhill
Manchester 1
Phone: 061 224 044
Telex: 86404
2 Queenwood, Sherwell
Lisington, Norfolk
Phone: 108 23767
- URUGUAY**
C.G.M. Uruguay S R L
Calle de Chile No. 1493
Montevideo
Cable: C.G.M. Uruguay
Phone: 91 79
Cable: CGUJA Montevideo
- VENEZUELA**
Equilab C.A.
1012 Av. R. Bolivar
1318 Rivas, Candelaria
Santa Elvadia
Aparicio Rivas
Caracas 100
Phone: 281 166, 31080
Telex: 2190 EGULAC
Cable: EGULAB Caracas
- WEST BERLIN**
Rohde & Schwarz
Handels-GmbH
Erich Reichen Pra. 10
1 Berlin
Phone: 63111 44 1016
Telex: 2181 696
Cable: RHODESCHWARZ Berlin
- ZAMBIA**
Bard and Tatlock (Zambia) Ltd
Chamber Musoma Road
P.O. Box 10386
Lusaka
Phone: 25115-6
Telex: 4271
Cable: PPRETTE Lusaka
Phone: 251
P.O. Box 10979
Noida
Phone: 1522 & 25134
Telex: 3481
Cable: PPRETTE Noida

Customers in the following countries
Belgium, Czechoslovakia, Hungary, Poland,
Romania, U.S.S.R. and Yugoslavia
Contact: Rohde & Schwarz, Tektronix Ges m B & H & CO KG
Sommerthergasse 20, A-1100 Wien, Austria. Phone Vienna 62 61 41. Telex Vienna 139333

Customers in all other countries should contact
Tektronix Inc., Export Marketing
P.O. Box 500, Beaverton, Oregon 97077, U.S.A.

Tektronix, Inc.

P. O. Box 500, Beaverton, Oregon 97077

Telephone: (503) 644-0161 TWX: 910-467-8708 TEKTRONIX BEAV. Cable: TEKTRONIX

FIELD ENGINEERING OFFICES

ALABAMA

*Huntsville 35801
Suite 8, 3322 S. Memorial Parkway
Phone (205)881-2912

ARIZONA

*Phoenix 85034
2643 E. University Drive
Suite 113
Phone (602)244-9795
Tucson Area: Enterprise 383

CALIFORNIA

*Concord 94520
2345 Stanwell Circle
Phone (415) 689-2710
From Oakland: (415) 254-5353

*Irvine 92714

16601 Hale Ave.
Phone (714)556-8080-89
(213)778-5225, 6

*Los Angeles

21300 Erwin Street
Woodland Hills 91367
Phone (213)999-1711

*San Diego 92111

7827 Convoy Court
Suite 401
Phone (714)292-7330

*Santa Clara 95051

3200 Coronado Drive
Phone (408)249-5500

COLORADO

*Denver
Suite 4A
14 Inverness Dr. East
Englewood 80110
Phone (303)773-1011
Telex: (Infocom) 45-4455

CONNECTICUT

Milford 06460
20 Commerce Park Road
Phone (203)877-1494

FLORIDA

*Fort Lauderdale 33311
1871 West Oakland Park Blvd.
Phone (305)731-1220
Also serves Puerto Rico and
U.S. Virgin Islands
From Miami: 947-6053

*Orlando 32803

Suite 109, 1040 Woodcock Rd.
Phone (305)894-3911
From The Cape Kennedy Area:
636-0343

Pensacola 32503

Suite 130, 4900 Bayou Blvd.
Phone (904)476-1897

GEORGIA

*Atlanta 30341
Suite 3, 2251 Perimeter Park
Phone (404)451-7241

HAWAII

Sales:
21300 Erwin Street
Woodland Hills, CA 91364
Phone ENTERprise 8072

Honolulu Service Center

EMC Corporation
2979 Ualena Street
Phone (808) 847-1138

ILLINOIS

*Chicago
5350 Keystone Ct.
Rolling Meadows 60008
Phone (312) 259-7580

INDIANA

*Indianapolis 46219
6121 East 30th Street
Phone (317)545-2351

KANSAS

*Kansas City
10580 Barkley
Suite 62
Overland Park, 66212
Phone (913)341-3344

LOUISIANA

*New Orleans
3004 34th St.
Metairie 70001
Phone (504)837-8454

MARYLAND

Baltimore
1526 York Road
Lutherville 21093
Phone (301) 321-7000

*Rockville 20850
2 Research Court
Phone (301)948-7151

MASSACHUSETTS

*Boston
482 Bedford Street
Lexington 02173
Phone (617) 861-6800

MICHIGAN

*Detroit
25882 Orchard Lake Rd.
Farmington Hills 48018
Phone (313) 478-5200

MINNESOTA

*St. Paul 55112
3563 N. Lexington Ave.
Phone (612)484-8571

MISSOURI

*St. Louis
422 Anglum Rd.
Hazelwood 63042
Phone (314)731-4695

NEW JERSEY

*Springfield 07081
964 South Springhold Avenue
Phone (201)379-1670

NEW MEXICO

*Albuquerque 87108
1258 Ortiz Drive S.E.
Phone (505)265-5541
Southern N.M. Area: ENTERprise 678
Southern Nevada Area: ENTERprise 678

NEW YORK

Albany
678 Troy Road
Latham 12110
Phone (518)785-3353

*Long Island

100 Crossways Park West
Woodbury, L.I. 11797
Phone (516) 364-9060
(212) 895-9215

Poughkeepsie 12603
31 Haight Avenue
Phone (914) 454-7540

Rochester 14623
1210 Jefferson Rd.
Phone (716)244-2600

*Syracuse

1 Northern Concourse
North Syracuse 13212
Phone (315)455-6661
From New York: (800)962-1095

NORTH CAROLINA

*Raleigh 27612
Suite 104
3725 National Dr.
Phone (919)782-5624

OHIO

*Cleveland 44129
5689 Pearl Road
Phone (216)884-6558

*Dayton 45449
501 Progress Rd.
Phone (513)859-3681

OKLAHOMA

Oklahoma City 73105
Suite 201
800 N.E. 63rd
Phone (405)848-3361

OREGON

Portland
7000 S.W. Hampton St.
Suite 121
Tigard, Oregon 97223
Phone: (503)620-9100

Factory Service Center
Tektronix Industrial Park
Beaverton 97077
Phone (503)644-0161
TWX: 910-467-8708

PENNSYLVANIA

*Philadelphia
1720 Walton Road
Blue Bell 19422
Phone (215)825-6400
From Harrisburg, Lancaster, and
York Area call, ENTERprise 1-0631

*Pittsburgh

3834 Northern Pike
Monroeville 15146
Phone (412) 373-3250

TEXAS

*Dallas 75240
4455 Sigma Road
Phone (214)233-7791

*Houston 77036

5755 Bonhomme
Suite 420
Phone (713)783-1910

San Antonio 78226
3311 Rosslawn
Phone (512)434-4334

UTAH

*Salt Lake City 84115
65 West 2950 South
Phone (801)484-8501

VIRGINIA

Hampton 23666
1329 C Coliseum Dr.
Phone (804)826-4020

WASHINGTON

*Seattle 98188
641 Industry Drive
Phone (206)575-0180

*Field Office/Service Center
iService Center