

# OPERATING INSTRUCTIONS

model 535  
DUAL GRAPHIC EQUALIZER

model 533  
GRAPHIC EQUALIZER

## Universal Audio

products of



**UNITED RECORDING ELECTRONICS INDUSTRIES**

8460 SAN FERNANDO RD., SUN VALLEY, CALIFORNIA 91352  
TELEX 65-1389 UREI SNVY

(213) 767-1000

A small logo consisting of the letters 'UREI' in a stylized font, followed by the word 'company' in a smaller, lowercase font.

BEFORE PROCEEDING WITH COMPLETE UNPACKING AND SETUP,  
CONSULT UNPACKING AND INSPECTION INSTRUCTIONS ON PAGE 4

model 535  
DUAL GRAPHIC EQUALIZER

model 533  
GRAPHIC EQUALIZER

REPAIRS AND WARRANTY

This product is factory warranted to the original purchaser against defects in material and workmanship for one year after initial purchase. This limited warranty must be activated at the time of purchase by returning the registry portion of the Warranty Card to the factory. Should a malfunction ever occur, the dealer from whom the unit was purchased will be glad to handle return for factory repair. Please call or write to the factory for a Return Authorization Number which must accompany all repairs. For prompt service ship the unit prepaid directly to the factory with the RA Number visible on the shipping label. Be sure it is well packed in a sturdy carton, with shock-absorbing material such as foam rubber, styrofoam pellets or "bubble-pack" completely filling the remaining space. Particular attention should be paid to protecting the controls, switches, etc. Tape a note to the top of the unit describing the malfunction, and instructions for return. We will pay one-way return shipping costs on any in-warranty repair.

Because of specially selected components in this product, field repairs are not authorized during the warranty period, and attempts to perform repairs may invalidate the warranty.



**United Recording Electronics Industries**

8460 SAN FERNANDO ROAD, SUN VALLEY, CALIFORNIA 91352

(213) 767-1000

Printed in U.S.A.

© Copyright 1979, UREI

## TABLE OF CONTENTS

|  | PAGE |
|--|------|
| <u>SECTION I. INTRODUCTION</u>                     |      |
| 1.1 DESCRIPTION                                    | 1    |
| 1.2 SPECIFICATIONS                                 | 2    |
| 1.3 CONTROLS                                       | 3    |
| <br>   |      |
| <u>SECTION II. INSPECTION AND INSTALLATION</u>     |      |
| 2.1 UNPACKING AND INSPECTION                       | 4    |
| 2.2 ENVIRONMENTAL CONSIDERATIONS                   | 4    |
| 2.3 POWERING                                       | 4    |
| 2.4 LINE VOLTAGE SWITCH                            | 5    |
| 2.5 EXTERNAL CONNECTIONS                           | 5    |
| 2.5.1 MODEL 301 XLR/QG ADAPTER                     | 6A   |
| 2.6 IMPEDANCE AND TERMINATION                      | 7    |
| 2.7 SIGNAL LEVEL AND OVERLOAD DETECTOR             | 8    |
| 2.8 ACCESSORIES                                    | 8    |
| 2.9 RACK MOUNTING A MODEL 533                      | 8    |
| 2.10 RACK MOUNTING TWO UNITS (MODEL 533)           | 9    |
| <br>   |      |
| <u>SECTION III. OPERATING INSTRUCTIONS</u>         |      |
| 3.1 GENERAL  | 11   |
| 3.2 SYSTEM CHECK                                   | 11   |
| 3.3 EXPERIMENTATION                                | 11   |
| 3.4 DOCUMENTATION                                  | 11   |
| 3.5 APPLICATION                                    | 11   |
| 3.5.1 OBJECTIVE MEASUREMENTS VS SUBJECTIVE HEARING | 13   |
| 3.5.2 ADDITIONAL HINTS                             | 13   |
| 3.5.3 SPECTRAL DISTRIBUTION IN THE AUDIO SIGNAL    | 14   |
| 3.5.4 EQ SYSTEMS AND LIMITERS                      | 14   |
| 3.6 DISCUSSION OF EQUALIZATION                     | 15   |
| 3.6.1 BEFORE EQUALIZATION                          | 17   |
| 3.6.2 MEASUREMENT TECHNIQUES                       | 18   |
| 3.6.3 ADJUSTMENT OF EQUALIZERS                     | 19   |
| 3.6.4 SOME PROBLEMS WITH CORRECTIVE ROOM EQ        | 19   |
| 3.6.5 FEEDBACK SUPPRESSION                         | 20   |
| 3.7 GAIN STRUCTURE AND SIGNAL-TO-NOISE             | 21   |
| 3.8 INPUT LEVEL                                    | 22   |
| 3.9 OVERLOAD INDICATOR                             | 22   |
| <br>   |      |
| <u>SECTION IV. THEORY OF OPERATION</u>             |      |
| 4.1 GENERAL  | 23   |
| 4.2 INPUT AMPLIFIER                                | 23   |
| 4.3 GAIN AMPLIFIER                                 | 23   |
| 4.4 GRAPHIC EQUALIZER                              | 23   |
| 4.4.1 GENERAL                                      | 23   |
| 4.4.2 FILTERS                                      | 23   |

TABLE OF CONTENTS (Continued)

|                           | PAGE |
|---------------------------|------|
| 4.4.3 THE ACTIVE INDUCTOR | 25   |
| 4.5 OUTPUT AMPLIFIER      | 26   |
| 4.6 OVERLOAD INDICATOR    | 26   |
| 4.7 POWER SUPPLY          | 26   |

SECTION V. MAINTENANCE

|                           |    |
|---------------------------|----|
| 5.1 GENERAL               | 27 |
| 5.2 REPAIRS AND WARRANTY  | 27 |
| 5.3 SERVICE ADJUSTMENTS   | 27 |
| 5.3.1 COMMON MODE BALANCE | 27 |
| 5.3.2 OFFSET ADJUSTMENT   | 28 |
| 5.4 CLEANING              | 28 |
| 5.5 ON OP AMPS            | 29 |

SECTION VI. ILLUSTRATION

|                                     |  |
|-------------------------------------|--|
| SCHEMATIC DIAGRAM OF UREI MODEL 533 |  |
| SCHEMATIC DIAGRAM OF UREI MODEL 535 |  |

SECTION I  
INTRODUCTION

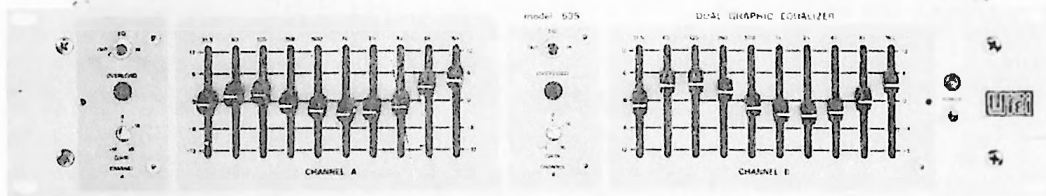

FIGURE 1. MODEL 535 FRONT PANEL.

NOTE: This manual contains complete instructions for the operation of the two-channel "Dual Graphic Equalizer" Model 535.

However, this manual is also intended for the single channel "Graphic Equalizer" Model 533. If used with a Model 533, all references to the two-channel unit should be disregarded.

### 1.1 DESCRIPTION

The Model 535 Dual Graphic Equalizer is a studio quality product which has wide application in recording, sound reinforcement, radio and TV production, and high fidelity music systems.

The system is designed to operate at any nominal level from as low as -20 dB (Ref. 0.775 V) allowing its use with low level mixers, high or low impedances, and balanced or single-ended circuits. The Model 535 provides 12 dB of boost or cut at each of its 10 frequencies which are centered at ISO 1-octave increments from 31.5 Hz to 16 kHz. The positions of the control arms of the vertical, stepless controls provide a graphic representation of the response curve selected.

The filters are active, minimum phase, 2-pole synthesized LC networks, whose skirts properly combine for minimum ripple and phase shift when used in combination. A front panel control adjusts the gain from -10 dB to +20 dB. Bypass switches permit switching the equalization out for A-B tests. An optional (SC-1) security cover may be installed to protect all operating controls against inadvertent disturbance or tampering in fixed installations.

## 1.2 SPECIFICATIONS

### ELECTRICAL (EACH CHANNEL):

INPUT: Balanced bridging, differential amplifier.

INPUT IMPEDANCE: 40 kohms, used as balanced input.  
20 kohms, used as unbalanced  
(single-ended) input.

MAXIMUM INPUT LEVEL: +20 dB (7.75 volts).

EQUIVALENT INPUT NOISE: Less than -90 dBm. 15.7 kHz noise bandwidth  
with all controls set flat, output termina-  
ted with 600 ohm load (Model 535, -88 dBm).

GAIN: Variable, -10 dB to +20 dB, with front  
panel control.

FREQUENCY RESPONSE:  $\pm 1$  dB, 20-20,000 Hz (with no EQ).

OUTPUT: Floating, transformer isolated.

OUTPUT LOAD: 150 ohms or greater.

POWER OUTPUT: +24 dBm into 600 ohm load (12.28 volts),  
+20 dB into 150 ohm load (7.75 volts).

DISTORTION: Less than 0.25% THD, 30 Hz to 15 kHz at  
maximum rated output.

FILTER TYPE: 2-pole synthesized L-C.

FILTER BANDWIDTH: 1-octave at -3 dB points with 8 dB  
boost or cut.

CENTER FREQUENCIES: Standard ISO (Hz) 31.5 63 125 250 500  
1k 2k 4k 8k 16k.

FREQUENCY ACCURACY:  $\pm 3\%$  of center frequency.

RANGE OF BOOST AND CUT: 12 dB, single filter section.

CALIBRATION OF BOOST AND CUT: Within 1 dB of indicated setting, 0 to  
 $\pm 6$  dB, within 1.5 dB of indicated  
setting,  $\pm 6$  to  $\pm 12$  dB, (single  
filter section).

CHANNEL SEPARATION: 60 dB worst case at high frequencies,  
typically better than 80 dB.

MISCELLANEOUS:

POWER REQUIREMENTS: 100-125 VAC or 200-250 VAC, 50/60 Hz,  
switch selectable, less than 10 W.

ENVIRONMENT: Operating 0°C to +50°C (+32°F to +122°F);  
storage -20°C to +60°C (-4°F to +140°F).

CONNECTIONS: Input and output, through rear chassis  
barrier strip, or XLR/QG connectors  
through Model 301 accessory adapter;  
Power through 3-wire power cable;  
Model 533 utilizes IEC style connector  
and power cord. (See Installation  
Instructions, Section 2.5.)

PHYSICAL CHARACTERISTICS:

DIMENSIONS: Model 535, 483 x 89 mm rack panel; depth  
behind panel 203 mm. (19" x 3-1/2" x 8");  
Model 533, 216 x 89 mm rack panel; depth  
behind panel 190 mm (8-1/2" x 3-1/2" x  
7-1/2").

FINISH: Panel is 3.18 mm (1/8") brushed clear  
anodized aluminum, in two shades.  
Chassis is cadmium plated steel.

WEIGHT: Model 535, 4.31 kg (9.5 pounds);  
Model 533, 2.95 kg (6.5 pounds).

SHIPPING WEIGHT: Model 535, 6.35 kg (14 pounds);  
Model 533, 4.08 kg (9 pounds).

ACCESSORIES: Model SC-1 Security Cover, smoke gray  
transparent plastic; covers all operating  
controls (Model 535 only).

Model 301 XLR/QG adapter; two needed for  
Model 535. One adapter provides connec-  
tions for signal input and output.

1.3 CONTROLS:

EQUALIZATION: Vertical slide controls, continuously  
variable 0 to ±12 dB.

GAIN: Screwdriver adjustable from -10 dB to  
+20 dB.

EQ IN/OUT: Front panel toggle switch.

POWER: Front panel toggle switch.

INDICATORS: LED, Power ON;  
LED, Overload Condition, levels monitored  
at 3 circuit points;

MAINS VOLTAGE: Rear panel slide switch, 115/230 volts.

## SECTION II

### INSPECTION AND INSTALLATION

#### 2.1 UNPACKING AND INSPECTION

Your Model 535 was carefully packed at the factory, and the container was designed to protect the unit from rough handling. Nevertheless, we recommend careful examination of the shipping carton and its contents for any sign of physical damage which could have occurred in transit.

If damage is evident, do not destroy any of the packing material or the carton, and immediately notify the carrier of a possible claim for damage. Shipping claims must be made by the consignee.

The shipment should include:

Model 535 Dual Graphic Equalizer

UREI Instruction Manual (this book)

Two-part Warranty Card bearing the same serial number as the Model 535.

Mounting screws and finish washers  
(for rack mounting of 535 only).

#### 2.2 ENVIRONMENTAL CONSIDERATIONS

The system will operate satisfactorily over a range of ambient temperatures from 0°C to +50°C (+32°F to 122°F), and up to 80% relative humidity.

If the system is installed in an equipment rack together with high heat producing equipment (such as power amplifiers), adequate ventilation should be provided to prolong the life of components. Also, while circuitry susceptible to hum pick-up is sufficiently shielded from moderate electromagnetic fields, installation should be planned to avoid mounting the system immediately adjacent to large power transformers, motors, etc.

#### 2.3 POWERING

The 535 may be operated from either 100-125 VAC or 200-250 VAC mains (50 or 60 Hz, single phase.) As indicated in Section 2.4, the nominal line voltage may be selected with a rear panel switch. BE SURE TO VERIFY BOTH THE ACTUAL LINE VOLTAGE, AND THE SETTING OF THE VOLTAGE SELECTOR SWITCH BEFORE CONNECTING THE 535 TO THE MAINS.



To comply with most Electrical Codes, the 535 is supplied with a three-wire AC cord, the grounding pin of which is connected to the chassis. In some installations this may create ground-loop problems. Ground loops can become very evident (as hum and buzz) if a significant potential difference exists between the AC conduit ground and the grounded metal enclosure in which the chassis is installed. If hum is experienced, check for the possibility of ground loops by using a 3-prong to 2-prong AC adapter, ungrounding the AC plug temporarily. This ungrounds the Model 535, and will probably cure the hum or buzz, but is not a substitute for proper system grounding. Be aware that unless the Model 535 Dual Graphic Equalizer is AC grounded, a safety hazard can exist. UREI accepts no responsibility for legal actions or for direct, incidental or consequential damages that may result from violation of any electrical codes.

#### 2.4 LINE VOLTAGE SWITCH

Unless a tag on the line cord specifies otherwise, the Model 535 was shipped ready for operation with nominal 115 VAC power mains. In order to change this for nominal 230 V (50 or 60 Hz), slide the VOLTAGE SELECTOR switch on the rear panel to the 230 position. The voltage is visible in a window next to the switch slot. Be sure to change the fuse to the correct value: 1/8-amp slo-blo when changing to 230 V operation or 1/4-amp slo-blo for 115 V operation. A small screwdriver should be used to move the recessed switch.

#### 2.5 EXTERNAL CONNECTIONS

Permanent input and output signal wires should be shielded cable, and connected in accordance with standard wiring practice, as indicated on the rear panel barrier strip. If the XLR/QG connectors are to be used, install the accessory Model 301 according to the instructions supplied with the adapter. (See also "Mounting Instructions," page 6A.)

If the Model 535 output is connected to a high impedance circuit, we recommend shunting the "+" and "COM" output terminals with a 620 ohm, 1/2 watt resistor. This assures optimum loading for the 535. (See section 2.6 regarding input termination).

(See Figures 2 and 3 on the following page)

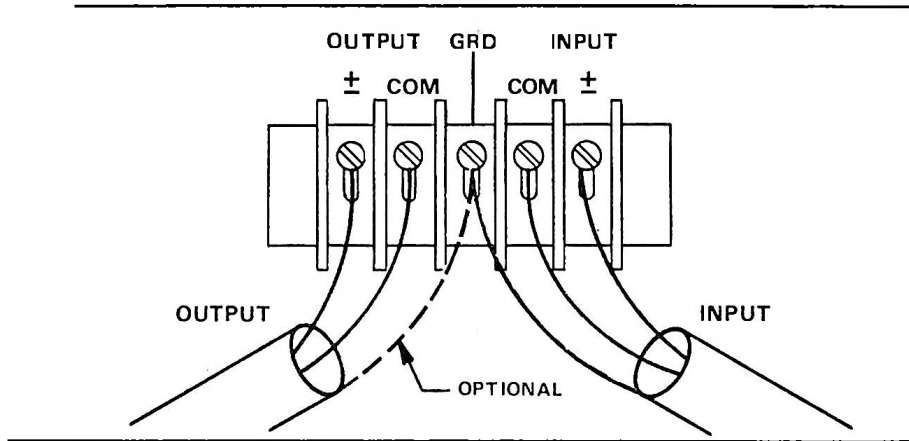

FIGURE 2. CONNECTING THE MODEL 535 WITH BALANCED INPUT AND BALANCED OUTPUT CIRCUITS.\*

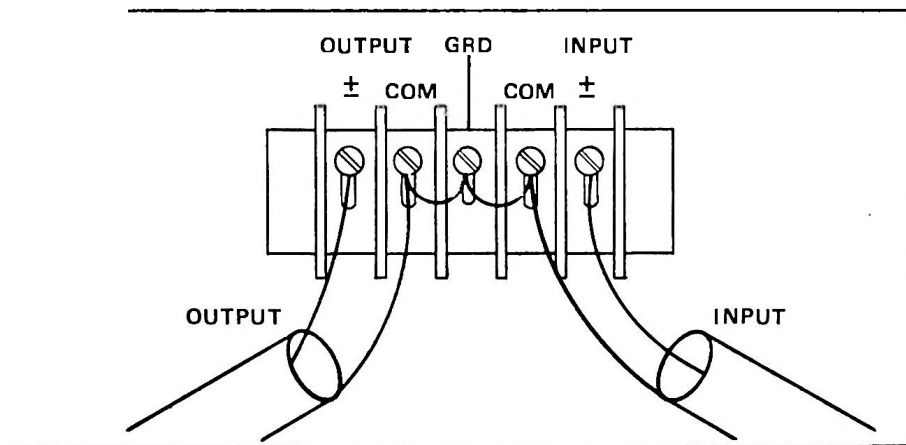
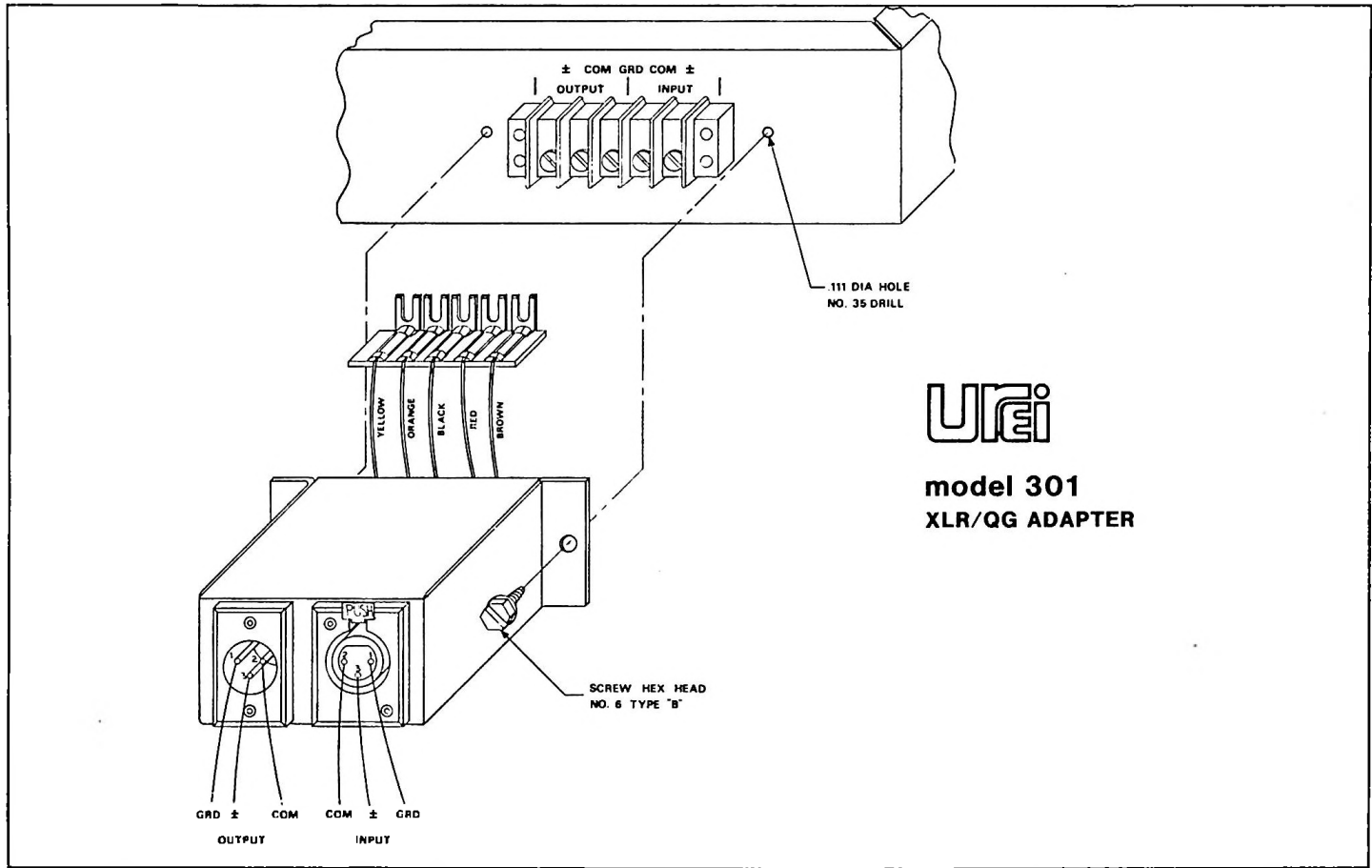

FIGURE 3. CONNECTING THE MODEL 535 WITH UNBALANCED INPUT AND UNBALANCED OUTPUT CIRCUITS.\*

\*With a balanced input and unbalanced output, or vice-versa, use the appropriate connections suggested by each of the above diagrams. No special switching or transformers are needed.



## 2.6 IMPEDANCE AND TERMINATION

Audio engineering had its roots in the telephone industry, and "600 ohm circuits" (together with their predecessors, "500 ohm circuits") are carry-overs from telephone transmission practices. Long audio transmission lines, like their video counterparts, must be properly sourced from and terminated in equipment which matches their characteristic impedance, if optimum frequency response and noise rejection are to be achieved.

However, transmission line theory and techniques are not only unnecessary but impractical within modern recording studios, broadcast studios and other local audio systems where transmission circuits are seldom more than several hundred feet in length. The advent of negative feedback circuitry and solid-state electronics has spawned modern audio amplifiers and other signal processing devices having source impedances of only a few ohms. They are essentially indifferent to load impedances and by varying their output current inversely to changes in load impedance, maintain the same output voltage into any load impedance above a rated minimum, with no change in frequency response.

Modern audio systems, therefore, utilize amplifiers and other active devices which have very low output impedances and high (10k to 50k) input impedances. These products may thus be cascaded (operated in series), or many inputs may be connected to a single output of a preceding device, without regard to impedance "matching". Switching, patching, etc. is simplified because "double loads" and "unterminated" bugaboos are essentially eliminated. "Floating" (ungrounded) transformer outputs minimize ground loop problems, and differential transformerless input circuitry (or input transformers) minimize common mode noise or interference which may be induced into the interconnecting wires or cables.

Where audio must be transmitted through cables or wire pairs of more than several hundred feet in length, however, transmission line termination practices should still be observed.

The Model 535 has input impedances of 40 kohms (40,000 ohms) when used in a balanced, differential input configuration, and 20 kohms (20,000 ohms) when used unbalanced (one side grounded). This makes the 535 suitable for use with any nominal source impedance, low or high. Only when it is used from a source which requires a low impedance termination (such as a 600-ohm transmission line or older vacuum-tube equipment) will a source termination resistor be required at the 535 input.

## 2.7 SIGNAL LEVEL AND OVERLOAD DETECTOR

The Model 535's differential input amplifiers are capable of being driven by signals up to a level of +20 dB (Ref. 0.775 V rms), above which clipping and distortion occurs. The overload LED turns on when peak signals approach the clipping level, and it will remain on long enough to be seen even if the excess signal is only a brief transient. To avoid audible distortion, when the LED indicator flashes more than occasionally, either lower the output level of the source feeding the equalizer, or use an external attenuation pad.

Because of the possible combination of control settings, the overload is monitored at several points in the circuit:

1. Input amplifier (maximum signal level +20 dB, ref. 0.775 V rms).
2. Filter amplifiers, which could be driven into clipping as a result of boost equalization.
3. Output amplifier, which is capable of delivering +24 dBm into a 600-ohm load (12.3 V rms), or +26 dBm\* into a 150-ohm load (7.75 V rms).

\*NOTE: +26 dBm into 150 ohms is equivalent to +20 dB referenced to 0.775 volts, i.e., 7.75 V rms.

## 2.8 ACCESSORIES

A security cover (SC-1) may be installed over the front panel of the Model 535 only. This protects all controls from unwanted adjustments. Only the power switch remains accessible. The smoke gray plexiglas cover is transparent enough to allow viewing of the control settings. The Model 301 adapter is available for the use of XLR/QG connectors; two are needed for the Model 535.

## 2.9 RACK MOUNTING A MODEL 533

The SR-21 kit (optional) allows mounting of one 533 in a standard 19" USASI rack. The unit occupies two standard spaces (3-1/2" high). The SR-21 kit should contain the following items:

| QUANTITY | DESCRIPTION            | UREI PART NUMBER |
|----------|------------------------|------------------|
| 2        | Rack Adapter Angles    | 25-12108         |
| 2        | Rack Extensions        | 25-12109         |
| 4        | #6-32 Oval Head Screws |                  |
| 4        | #6 Lock Washers        |                  |
| 4        | #6-32 Nuts             |                  |
| 4        | #8-32 Pan Head Screws  |                  |
| 4        | #8 Lock Washers        |                  |

The SR-21 Installation Procedure is as follows:  
(Refer to Figure 4)

1. Using the #6-32 screws, lockwashers, and nuts, mount the angles to the back side of the rack extensions. Do not tighten the screws at this time.
2. Using the #8-32 screws and lock washers, mount the angle and rack extension assemblies to the tapped holes in the sides of the 533. Do not tighten the screws at this time.
3. The 533 front panel is adjustable to allow optimum alignment of the front panel with the rack extensions. For precise alignment, loosen the front panel mounting screws, as well as the top and bottom cover screws (1/2 turn is adequate). Adjust the relative positions of the brackets and panels, and then tighten all hardware. SEE SECTION 2.5 BEFORE INSTALLING THE ASSEMBLY IN A RACK.

#### 2.10 RACK MOUNTING TWO UNITS (MODEL 533)

The DR-21 kit (optional) allows mounting of two 533's side by side in a standard 19" USASI rack. The assembly occupies two standard spaces (3-1/2" high). The DR-21 kit should contain the following items:

| QUANTITY | DESCRIPTION           | UREI PART NUMBER |
|----------|-----------------------|------------------|
| 2        | Joining Plates        | 25-11168         |
| 2        | Rack Mounting Angles  | 25-12106         |
| 2        | Spacer Plates         | 25-12107         |
| 4        | #8-32 Pan Head Screws |                  |
| 4        | #8 Lock Washers       |                  |

The DR-21 Installation Procedure is as follows:  
(Refer to Figure 5)

1. Place the two 533's side by side, with front panels touching. Remove four screws from the top of each unit, as illustrated, to permit positioning of the joining plate. Replace the screws through the plate and covers, but do not tighten completely at this time.
2. Turn the assembly upside down, and install the bottom joining plate in the same fashion as the top joining plate (step 1).

3. Using the #8-32 screws and lock washers, mount one angle and one spacer plate to each side of the 533 assembly. The spacer plates should be located between the angles and the 533 chassis. The mounting holes in the 533 are tapped, so nuts are not required. Do not tighten the screws at this time.

4. The 533 front panels are adjustable to allow optimum alignment of the front panels with the rack mounting angles. For precise alignment, loosen the front panel mounting screws, as well as the top and bottom cover screws (1/2 turn is adequate). Adjust the relative positions of the angles and panels, and then tighten all hardware. SEE SECTION 2.5 BEFORE INSTALLING THE ASSEMBLY IN A RACK.

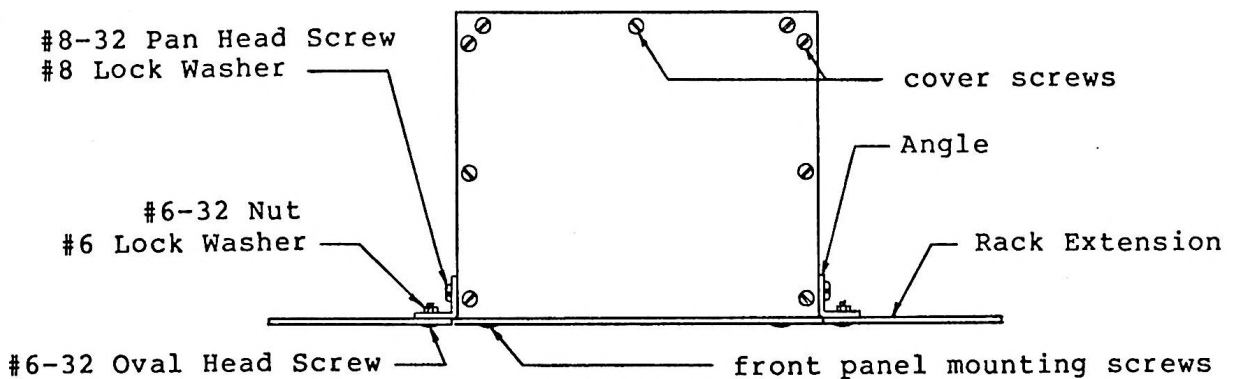

FIGURE 4. MOUNTING DETAILS FOR SR-21 RACK MOUNT KIT.

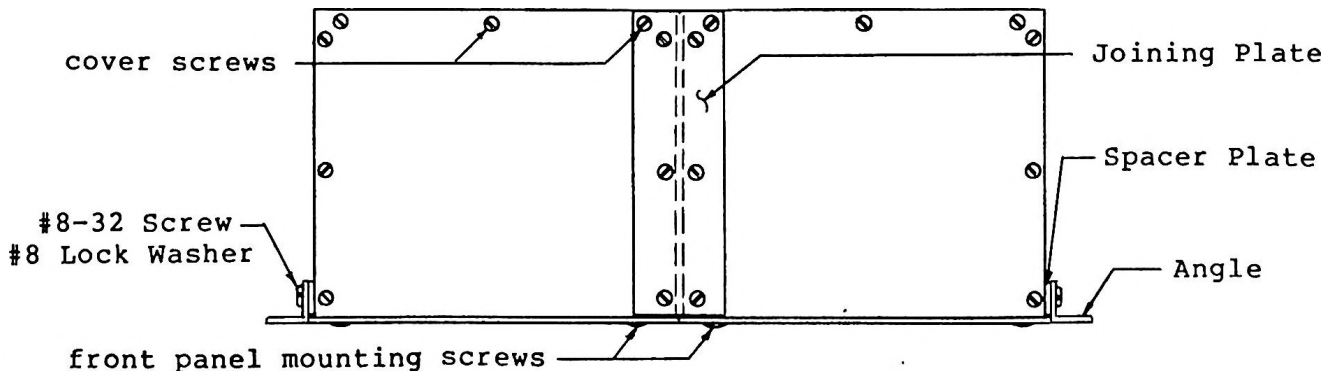

FIGURE 5. MOUNTING DETAILS FOR DR-21 RACK MOUNT KIT.

## SECTION III

### OPERATING INSTRUCTIONS

#### 3.1 GENERAL

After the Model 535 Graphic Equalizer has been installed and is connected to both the signal source and the succeeding equipment according to Section II, power may be switched ON. Set controls:

Gain Control -- To unity gain.

All Frequency Controls -- To the zero line of the front panel, producing no effect on the frequency response.

#### 3.2 SYSTEM CHECK

Apply program material and monitor the output signal while the EQ switch is in the OUT position. The signal should be passed through the Model 535 without loss or gain in amplitude, or frequency alteration. No change should be noticeable when the EQ switch is set to the IN position.

#### 3.3 EXPERIMENTATION

To become familiar with the range and effect of the individual filters and their almost unlimited number of combinations, it is helpful to "play" with the controls and listen to the change in some familiar program material. The EQ switch is very useful to make an instant A-B comparison while altering adjustments.

#### 3.4 DOCUMENTATION

The very nature of a graphic equalizer will result in many different control settings. For later duplication of a certain sound, or of a corrective filter shape, it is necessary to document the position of the controls (frequency, boost and/or cut, and gain). This is made convenient by the graphic layout of the Model 535's front panel and its calibrated markings. In addition, a frequency curve may be drawn with a suitable sweep generator and X-Y recorder system, such as the UREI Model 200/2000.

#### 3.5 APPLICATION

It will be helpful to study the editorial in the following paragraphs. Although the section is not intended to be a complete textbook, it shares some of the experiences we have gained during



the years our equalizers have been in use. Also, it should serve as a stimulant to experiment with the instrument. We believe that it is of primary importance for the user to know and understand the equipment and its capabilities. Some sections may not be of interest at this time, however it is beneficial to read through the entire text.

As in any other field, "practice is the key to success." Just as it is not reasonable to expect to get beautiful music out of a musical instrument the first time you play on it, it is also not reasonable to expect to immediately master the techniques necessary to adjust the Model 535 for the desired sound the first time you work with it.

Some of its many uses are listed below:

- (1) Recording studio frequency shaping of recorded material. The very low output noise and high signal handling capability make the Model 535 suitable for use in any studio situation.
- (2) Reduction of proximity effect due to close-talking use of cardioid microphones. A decrease of only 2 dB or so in the 200 to 400 Hz region may significantly improve the intelligibility of what otherwise would be a very "boomy" sound.
- (3) Elimination of excess high frequencies and sibilance, especially at high sound pressure levels. A slight reduction in level at 8 kHz may eliminate much of the harshness which is experienced when loudspeakers and amplifiers are operated close to their power limits.
- (4) Sound effect processing such as "Telephone Sound."
- (5) Room equalization.
- (6) Sound effects tapes for theatrical productions may be made through the Model 535 to ensure consistency of quality of the recorded material, and to pre-equalize for correct sound from the particular loudspeakers to be used. If the tapes are correctly equalized, adjustments during the show are reduced to volume adjustments and speaker selection. If the show goes on the road to some other auditorium, the Model 535 may be inserted in the line to account for different acoustics while retaining the original total balance of sounds from effect to effect.
- (7) Many sound systems are required to serve rooms in which different acoustic environments prevail in different areas: for example, the under balcony area of a theatre versus the balcony area. For such installations, use of one half of a Model 535 for one area and the other half of a Model 535 for another area may allow for more consistent response throughout the room.

### 3.5.1. OBJECTIVE MEASUREMENTS vs. SUBJECTIVE HEARING

Since the hearing process is subjective, each individual will have a different opinion of what constitutes "good sound" or "bad sound". Until science has found all the answers about the phenomenon of hearing, we will have to use the available tools to modify sound with a certain imprecision. This lack of ability to quantify the relationship which exists between the subjective response of the listener, and the objective measurements of amplitude-vs-frequency response, phase, distortion, etc., need not be a barrier to our efforts to "improve" the sounds that we hear.

We have a most sophisticated quality assessment mechanism which is specifically suited to do this job...the human ear. Therefore, the educated listener with good hearing will probably always be the standard of reference to decide if a sound has been accurately reproduced. However, accurate faithful reproduction is not always the goal, and in many circumstances it may not even be possible or desirable.

### 3.5.2. ADDITIONAL HINTS

The Model 535 Graphic Equalizer is a powerful tool for the audio engineer to modify, adjust, alter, enhance, destroy or reclaim the audio signal. The extreme result would be a sound that never existed before. In such instances, there are very few rules for what to do and what not to do with the equalizer controls...in creative equalization: whatever works is right.

It is good to begin the work in a controlled environment where there is enough time to experiment, and the freedom to do it "wrong" without offending someone else. Doing it the wrong way means to know what does not work! Start out with simple program material of various types and try to make it sound "better." Different program material will require different control settings.

Extreme filter settings are generally to be avoided. Of course special effects and corrective equalization of program material which must be saved may require such settings. The important thing is to avoid creating a new problem while correcting another.

Whenever a big notch in the frequency response of the filter is selected, it can cause important parts of the program material to be removed. It is possible to make adjacent notes on the musical scale differ considerably in level. If that's what is desired, fine. However, if you are trying to correct for problems which would better be dealt with by choice of microphone, microphone positioning, acoustic control, etc., you may run into trouble. The 535 (or any other such device) is not a lifesaver in an ocean of problems.

### 3.5.3. SPECTRAL DISTRIBUTION IN THE AUDIO SIGNAL

It may seem obvious, but we'll point it out anyway; a major advantage of a graphic equalizer is to be able to see at a glance what the instrument is doing. The shape of the filter response is apparent immediately from the positions of the slide controls. This information, together with the knowledge of the spectral distribution of the program material, is very advantageous in arriving at a desired frequency response.

NOTE: The UREI Model 970 Vidigraf™ is an especially useful tool with which to view the program spectrum in a recording studio situation. It allows the operator to monitor the signal from a program source and to determine visually the relative levels of frequency bands.

We can arbitrarily divide the audible frequency spectrum into four sections: bass, lower midrange, upper midrange, and high frequencies. When we are concerned with wide bandwidth program material, we should remember that each of these frequency bands is important for its contribution to a full and balanced sound. Lack of bass frequencies will make the sound thin, while too much will make it boom. The lower midrange, which provides much of the rich and mellow texture to music, may make the program material sound muffled if too abundant. The upper midrange is necessary for clarity and articulation, but gives the program a "canned" quality if overused. The high frequencies in excess create a harsh sound, but if balanced, give the audio program a spaciousness which it would not otherwise have.

### 3.5.4. EQ SYSTEMS AND LIMITERS

The use of a compressor or limiter in the audio chain is frequently dictated by the system's headroom restraint, the dynamic range of program material, or aesthetic reasons. The question then arises, "do I put the limiter before or after the equalizer?" The answer is that generally the equalizer should be ahead of the limiter in the chain.

The equalizer, by its very nature, changes the frequency balance and harmonic relationships of the input signal. Frequencies that were greatest in amplitude at the input may not be so at the output. Conversely, some frequencies may be at a high level at the output due to the equalizer's action. The limiter, which is actuated by the level of the signal, should see the equalized or balanced signal.

The use of the equalizer prior to the limiter offers a further advantage, i.e., the program material may be equalized to optimize the limiter output by adjusting the input signal to the limiter.

As an example, if a recording has a large dynamic range and an excess of low frequencies, the equalizer would be able to reduce the level of the low frequencies fed to the limiter, thereby reducing the amount of limiting needed. It also enables the user to select a faster attack and release time on the limiter if needed for peak limiting. The excessive low frequencies would have restricted the speed at which the limiter could operate and still achieve the desired low distortion.

There are a few instances where the equalizer might be placed after the limiter, and that would be in a system where extreme uncontrollable dynamics are expected. These might otherwise overload the Model 535. However, these cases are very rare, and the exceptionally wide dynamic range of the 535 makes this situation even more unlikely.

### 3.6 DISCUSSION OF EQUALIZATION

The main reason for frequency response tailoring of audio systems is to compensate for response anomalies occurring in the system and its environment, and to adjust the system response curve to some desired shape. In some systems this means adjusting for best overall flatness of response through the entire audio range, and in other instances some different response shape is desirable.

Three important characteristics of audio systems may be improved by judicious application of corrective equalization techniques. They are:

- (1) **DISTORTION OF FREQUENCY RESPONSE BALANCE.**  
Sources of sound which may be amplified through a sound system start out with some specific frequency balance. If, in being processed through an audio system this balance is disturbed by variation in frequency response, then truly the sound has been distorted. For example, an instrument has a specific characteristic with regard to the levels of the various harmonics compared to the fundamental tone. If these signals are processed through an audio system with non-linear frequency response, then the resultant sound is simply not the distinctive sound which that instrument originally produced.
- (2) **SUSCEPTIBILITY TO FEEDBACK.**  
In public address and sound reinforcement systems, the maximum acoustic gain that may be obtained for a microphone in the vicinity of a loudspeaker which is part of that system, will be determined by the positive feedback loop created when sound from the loudspeaker enters the microphone, reinforcing the signal level until the system goes into oscillation. This positive feedback problem is aggravated if some frequencies in the

audio range are reproduced at a higher level than the rest of the frequency band. If the level of these frequencies which are being reproduced at an exaggerated level can be reduced, then the sound system gain may be increased to some degree without feedback.

(3) INTELLIGIBILITY.

For an audience in an auditorium to understand a lecturer, or for a nightclub audience to hear the words which a vocalist is singing, there are two important requirements:

- (a) The sound level of the source must be sufficiently loud as to be heard clearly and not masked by other sounds which may be present in the listening environment.
- (b) The sound which the listener hears must be intelligible to him. It should not be distorted or garbled. There are a number of causes for poor intelligibility in a sound system. Among them are: amplifier or speaker distortion, frequency band masking, improper balance of direct and reverberant fields, and inadequate projection of the higher frequencies which are necessary for the recognition of words. The frequency band from approximately 1 kHz to 5 kHz is very important to the recognition of sibilant and consonant sounds, and if the sound system has inadequate output in this frequency band, or if other bands have considerably greater output which "cover up" the sounds in the intelligibility band, the words may simply not be understood. Equalization is very helpful to correct some of these problems.

The remainder of this section is concerned with a general description of the equalization process and some suggestions for successful application of the Model 535 are given. Techniques are continuously being improved upon, therefore this discussion should be considered only as a starting point for those who are new to the field, and as a general review for those who are already proficient in the methods used.

Those interested in more complete information on the general subject of sound system design and corrective equalization are encouraged to study specialized literature\* and/or participate in seminars dedicated to audio acoustics, etc.

An excellent series of continuing seminars are conducted in various cities by Don and Carolyn Davis. For further information, and a schedule of their regular seminars, contact:

"Synergetic Audio Concepts"  
P.O. Box 1134  
Tustin, CA 92680

### 3.6.1 BEFORE EQUALIZATION

Corrective equalization is only one of the solutions to the problems faced by designers or users of audio systems. Applied correctly, it is a powerful tool; but if it is assumed to be a cure-all without careful consideration of other possible alternatives, results may be disappointing. If the sound system is not thoroughly checked out before equalization procedures are attempted, much time may be wasted. Therefore we feel that it is important to mention a few of the tests which should be made prior to the start of corrective room equalization. The list is not intended to be exhaustive, rather to point out that unless you know what the sound system IS doing, you may find it difficult (if not impossible) to make it do what it SHOULD do.

#### A PARTIAL CHECK-LIST OF PROCEDURES BEFORE EQUALIZATION:

- (1) At normal operating levels, check the frequency response and the signal-to-noise and distortion characteristics of the individual components of the system and the system as a whole.
- (2) Check phasing (polarity) of signal lines from all inputs through to the amplifier outputs.
- (3) Check loudspeakers to see that all units function, that there are no rattles due to loose screws or units poorly attached to walls. Check phasing of all loudspeakers, even of the several drivers within one cabinet. Check loudspeaker aiming.
- (4) Check phasing of all microphones.

---

\* Sound System Engineering, by Don and Carolyn Davis, Published by Howard W. Sams, Inc., Indianapolis, Indiana 46268, Copyright 1975.

- (5) Check that all electronic components of the system are connected correctly, that correct signal levels are observed, that loads are where they should be and not where they should not be. Check the system for oscillations, R.F. interference, and hum.
- (6) Make sure you have a good system ground, and that shielding and grounding are done in accordance with good practices.
- (7) Make sure that the AC electrical power to the system is of good quality, adequately protected, and that the wire size is sufficiently large to avoid excessive voltage drop when large amounts of power are drawn.

### 3.6.2 MEASUREMENT TECHNIQUES

Several different methods are in use to measure the frequency response characteristic of a sound system in its acoustic environment:

- (1) Pink noise, measured in 1/3-octave bands and displayed on a real-time spectrum analyzer or suitable LED-display.
- (2) Swept sine waves, measured on an audio voltmeter or plotted on a graphic recorder.
- (3) Swept sine waves, frequency modulated with a constant percentage bandwidth (Warble Tone) generated and plotted with the UREI 200/2000 Recorder system.
- (4) Pulsed signals, generated and measured with the UREI SONIPULSE™ system.
- (5) Other methods, as for example "Time Delay Spectrometry," are in the development stage and may become important alternate solutions in the future.

Basically, all of the measurement methods are similar in technique, differing only in hardware. They all involve generating a known quantity of audio signal, transmitting it through the sound system, and reading the results through a calibrated microphone and readout device. The results will closely resemble each other if comparative measurements are made, presuming correct application of the various methods.

The microphone is located in the listening area, and its position is changed to see if there are response variations in different locations. The response variations are then averaged together to make what is called the RAW HOUSE CURVE (Figure 6). Corrective

equalization procedures are based on this curve. Many problems associated with level balance between multiple speakers in large areas, acoustic deficiencies, and speaker aiming and locating faults will show up on the curves taken in various locations in the listening area. For good results, these faults should be corrected by re-balancing of levels and re-aiming or relocating speakers -- not by equalization. In a system which uses the electronic crossover with a biamplified configuration, the balance should be checked and adjusted between low and high frequencies and between speakers covering different parts of the listening area.

### 3.6.3 ADJUSTMENT OF EQUALIZERS

Room equalization is performed as a series of approximations of control settings. Looking at the sample RAW HOUSE CURVE in Figure 6, we can infer that if an inverse electrical response curve were placed in the audio chain that the result would be a flat frequency response.

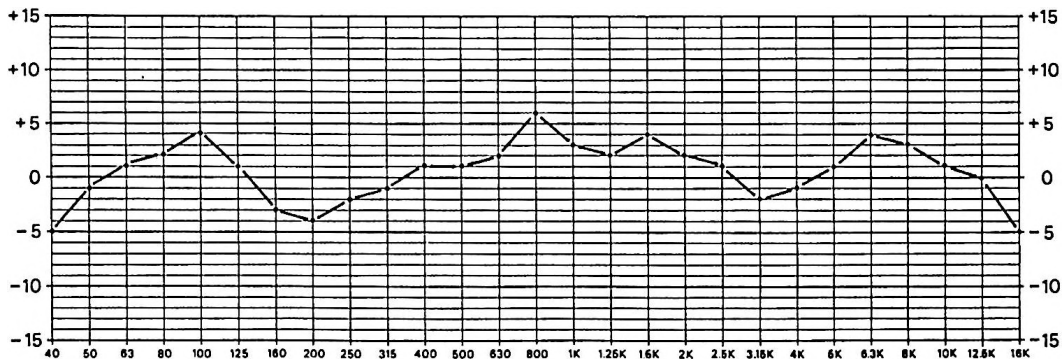

FIGURE 6.  
TYPICAL RAW HOUSE CURVE OBTAINED FROM SONIPULSE™ MEASUREMENTS.

The octave graphic graphic equalizer is the tool with which this inverse curve is approximated. Because there are combining effects between adjacent filters, it is necessary to make settings on the equalizer and then to re-check the room response to see if the adjustments were correct. Additional adjustments and measurements may be made until the desired results are obtained.

### 3.6.4 SOME PROBLEMS WITH CORRECTIVE ROOM EQ

As stated earlier, the process of corrective equalization of sound systems is not a cure-all. There are some rooms which, because of very long reverberation times and poor acoustic configuration, cannot be significantly improved. There are a few others



in which the acoustics and the sound system are already so well balanced that there is little need for correction. It is for the majority of situations which lie between unsolvable and relatively perfect that corrective equalization is intended.

Many of the problems that people seem to have when performing corrective equalization stem from a tendency to "overkill." It has been found in practice that it is not desirable to attempt to equalize to the "last dB" all minor anomalies in the response of an acoustical system, as this often results in an artificial or processed sound. Also, it sometimes requires extreme filter settings with introduction of unwanted phase shift, which may cause more problems than the EQ solves. In general, if the final results are within a 3 dB envelope of the desired theoretical values, the equalization should be considered successful.

Attention should also be given to the fact that different frequencies are attenuated differently when traveling through air. As the distance between the sound source and the listening position (or position of the measuring microphone) increases, it is natural for high frequencies to be attenuated more. Therefore, if equalization is adjusted to create a perfectly "flat" response, particularly throughout a large room, the resulting sound will be excessively bright. A house curve which produces a natural response in sound systems is subjective and a matter of personal preference, as well as a function of the primary use of the location. However, a flat response up to about 3 kHz and then an attenuation of 3 dB per octave above 3 kHz is frequently used in sound reinforcement. In recording studios and monitoring rooms, the response is usually flat to higher frequencies.

Widely disparate settings of adjacent controls should be avoided if at all possible. A control panel in which adjacent adjustment knobs are 8 to 10 dB apart may look interesting, but the resultant sound will not be natural. It is good to remember that the trained human ear is still the ultimate judge of any equalization.

#### 3.6.5 FEEDBACK SUPPRESSION

An improvement of a system's tendency to feedback should be attempted after the general equalization of the frequency response is performed. The result will be a higher amplifier gain setting than was possible before feedback suppression. Remember: an improvement of 3 dB is equal to twice the previously available power. To prevent ringing, it is best to adjust the gain at least 3 dB below the threshold of feedback.

### 3.7 GAIN STRUCTURE AND SIGNAL-TO-NOISE

Only the correct gain structure throughout the entire audio system will enable the user to take advantage of the optimum signal-to-noise ratio built into the individual components. In this discussion, the matching between the equalizer and a following power amplifier is considered.

The Model 535 was designed for an average signal level at its input of approximately 0 dB (Ref. 0.775 V rms). This guarantees 20 dB of headroom; that is, peaks may be 20 dB above the average level before any clipping could occur. Residual output noise from the Model 535 is 90 dB below the average signal level, or >110 dB below maximum output level, and therefore inaudible.

The specification of the power amplifier may state an input sensitivity of 0.775 volts (0 dB) for maximum output power. This means that any signal level which is greater than 0 dB causes overload of the amplifier. As stated before, the maximum output level from the equalizer may have peak values of approximately +20 dB. Obviously, the equipment is not properly matched!

Two solutions shall be discussed:

- (1) We reduce the level through the equalizer to -20 dB average signal level. This value is safe to provide us with 20 dB of headroom in the power amplifier. At the same time, however, we reduce our signal-to-noise ratio. As was mentioned before, the residual noise from the equalizer is 90 dB below a 0 dB reference level. If our average signal level is -20 dB, only 70 dB of signal-to-noise ratio remains, which may be adequate, but is a limitation.
- (2) A better solution would be to leave the average signal level through the equalizer at the optimum level of 0 dB, but add a 20 dB attenuator between its output and the power amplifier's input. This reduces the average signal level and the residual noise from the equalizer (and other possible sources). The original 90 dB below average signals or 110 dB below peak signals is maintained. In many cases the gain control of the power amplifier may be used as the suggested attenuator (so long as an input stage in the power amplifier will not be overdriven).

### 3.8 INPUT LEVEL

If the equalization controls are in the flat position or attenuated, no special care is necessary with regard to input signal level other than keeping it below +20 dB (Ref. 0.775 V rms). However, if any of the controls are adjusted for boost, then it must be remembered that at the frequencies affected by that control the gain of the equalizer becomes greater, and the maximum input signal level which is allowable at those frequencies is reduced by the amount of boost at those frequencies.

At moderate amounts of boost, this should not present a problem, but if, for example, all controls are in full boost, some frequencies will be boosted as much as 20 dB due to the combining effect of adjacent filters. Under such circumstances, the signal should be reduced with the Gain control to a safe level to avoid overload.

### 3.9 OVERLOAD INDICATOR

Overload conditions are monitored throughout the equalizer. The LED flashes ON when peak signals approach the clipping level in any part of the circuit. It will remain ON long enough to be seen even if the excess signal is only a brief transient. To avoid audible distortion, when the LED indicator flashes more than occasionally, the signal level must be lowered.

A listening test may show that the LED flashes before distortion is audible. This may be due to high amplitude, short duration transients, and you may never hear the resulting overload, depending on program material, listening conditions, and yes, even your own ears. Therefore the overload LED, like all such indicators, should not be ignored.

SECTION IV  
THEORY OF OPERATION

4.1 GENERAL

This section provides a generalized description of the 535 circuitry, and should be used in conjunction with the schematic at the end of the manual.

4.2 INPUT AMPLIFIER

The signal is applied to a differential input amplifier (IC 1, sections A and D). The input accepts either balanced or unbalanced sources (see also Installation, section 2.5). Common mode rejection is factory adjusted with R1 and is typically better than 40 dB.

4.3 GAIN AMPLIFIER

IC 1B is a variable gain amplifier providing -15 to +15 dB of gain. Thus the stage has a gain range of 30 dB, allowing system gain from -10 to +20 dB.

4.4 GRAPHIC EQUALIZER

4.4.1 GENERAL

The Graphic Equalizer consists of 10 L-C-R band filters tuned to ISO center frequencies (IC 2A, B, C, D, 3C, D, 4A, B, C, D). Switch S1 selects either the input to or the output from this section as the input to the Output Amplifier.

4.4.2 FILTERS

The output of the gain amplifier is connected to the filter amplifiers IC 3A, B, and 5B. Each of the filter amplifiers is connected to a group of L-C-R filters. (Refer to Figure 7, next page.)

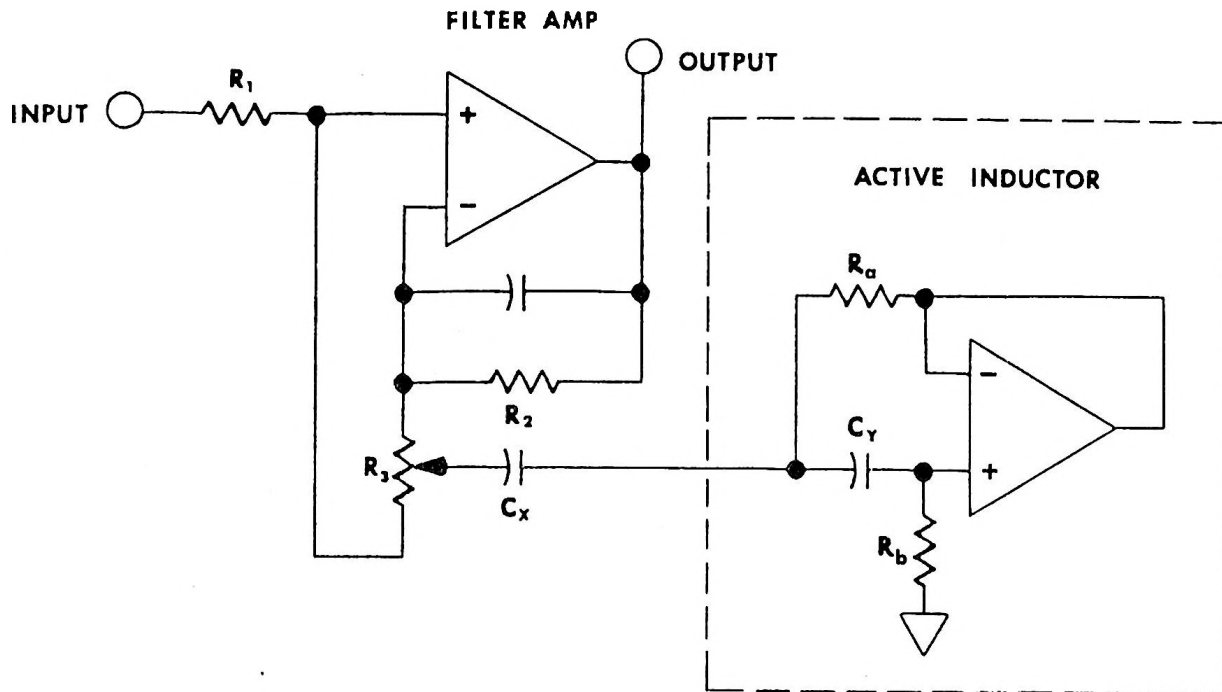

FIGURE 7. TYPICAL FILTER SCHEMATIC.

The filter amplifier is connected as a unity gain follower because  $R_1$  and  $R_2$  are equal. With the potentiometer connected as shown, consider the result if the wiper of the pot were connected to AC ground. As the wiper is moved towards the positive input of the filter amplifier, a voltage division of the input signal takes place, thus reducing the output of the amplifier. As the wiper of the pot is moved towards the negative input of the filter amplifier, a voltage division takes place also, but this voltage division is of the negative feedback; thus, as the impedance at the negative input of the amplifier is increased, the voltage at the output of the amplifier is decreased. With the control at midpoint, any voltage division occurs equally in the input signal and feedback signal, and the filter amplifier is once again a unity gain follower.

In the Model 535, the wiper of the potentiometer is connected to a synthesized series L-C circuit in which component values have been chosen to resonate at a given frequency and with a "Q" of 1 at approximately 8 dB of boost or cut. Because the wiper of the pot is connected to AC ground through the L-C network, the voltage division which takes place in the filter amplifier is effective only for the frequencies in the band covered by the individual L-C network. A total of 10 such L-C-R networks are used in the Model 535.

#### 4.4.3 THE ACTIVE INDUCTOR

The Model 535 does not use conventional coils to form its L-C-R networks. Rather, the inductors are synthesized through the use of a circuit known as an active inductor, as shown in Figure 7. To understand the operation of this circuit, examine the frequency response characteristic of a capacitor, as shown in Figure 8 (a) below.

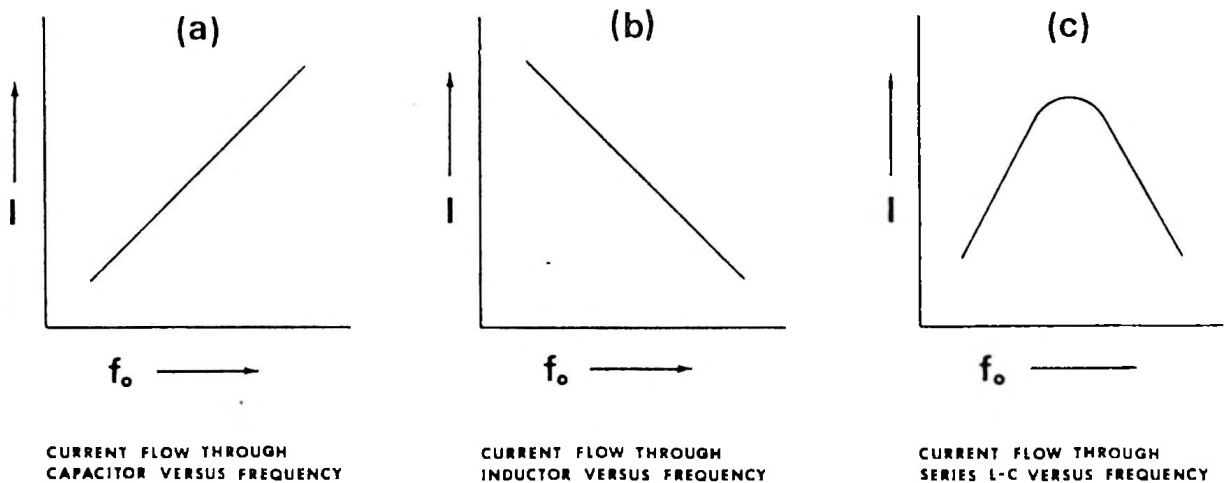

FIGURE 8. CURRENT FLOW VERSUS FREQUENCY CHARACTERISTICS FOR A CAPACITOR, AN INDUCTOR, AND THE TWO IN SERIES.

As frequency increases, capacitive reactance decreases and more current flows through the capacitor. An inductor, as seen in Figure 8 (b), functions in just the opposite manner; as frequency increases, inductive reactance increases and less current flows through the inductor. The active inductor circuit uses a capacitor and an operational amplifier to simulate the action of an inductor. If we remove capacitor  $C_y$  from the circuit in Figure 7, we see that current flows into the circuit through resistor  $R_a$  to the virtual ground of the operational amplifier output. If we now return capacitor  $C_y$  to the circuit we see that with increase in frequency the current flow through the capacitor will increase. This increase in current flow will be seen as an increase in voltage across resistor  $R_b$ , which will be reflected in an increase in output voltage of the operational amplifier. This increased voltage results in a decrease in current flow through resistor  $R_a$ . This change in current flow through resistor  $R_a$  follows the plot in Figure 8 (b), which is that of an inductor. The current flow through the active inductor in series with capacitor  $C_x$  is seen in Figure 8 (c), in which the peak current is achieved when the inductive reactance of the active inductor equals the capacitive reactance of the capacitor; this point is the resonant frequency of the circuit.

#### 4.5 OUTPUT AMPLIFIER

IC 5A together with transistors Q1 and Q2 form the output amplifier driving the transformer T2. The gain of the amplifier is set by the ratio of R54 and R53. The output transformer has a gain of 3 dB when terminated with a 600 ohm load.

#### 4.6 OVERLOAD DETECTOR

Under normal signal level conditions, the output of IC 5D is positive due to the negative bias at its inverting input. Thus, the LED is turned OFF. If the signal levels from the input amplifier through diode CR 5, from IC 1B through CR 4, or from the output amplifier through CR 3 exceed the threshold set by the ratio of R48 and R49, the overload detector amplifier changes its output state for approximately 0.1 seconds, and the LED indicates the overload condition.

The pulse-stretching network included in the positive feedback loop of the amplifier ensures that the LED remains ON long enough to be observed, even though the overload may have been caused by a very short duration signal peak.

#### 4.7 POWER SUPPLY

The power supply is bipolar, employing two integrated circuit voltage regulators VR1 and VR2 to provide low-ripple,  $\pm 18$  volt DC. Additional filter capacitors assure power supply stability and low noise.

The pilot LED is connected across the positive and negative sides of the power supply to indicate power ON condition.

SECTION V  
MAINTENANCE

5.1 GENERAL

The Model 535 is an all solid-state unit, ruggedly constructed with only the highest quality components. As such, it should provide years of trouble free use with normal care. All parts used are conservatively rated for their application, and workmanship meets the rigid standards you have learned to expect in UREI products.

NO SPECIAL PREVENTIVE MAINTENANCE IS REQUIRED.

REPAIRS AND WARRANTY

This product is factory warranted to the original purchaser against defects in material and workmanship for one year after initial purchase. This limited warranty must be activated at the time of purchase by returning the registry portion of the Warranty Card to the factory. Should a malfunction ever occur, the dealer from whom the unit was purchased will be glad to handle return for factory repair. Please call or write to the factory for a Return Authorization Number which must accompany all repairs. For prompt service ship the unit prepaid directly to the factory with the RA Number visible on the shipping label. Be sure it is well packed in a sturdy carton, with shock-absorbing material such as foam rubber, styrofoam pellets or "bubble-pack" completely filling the remaining space. Particular attention should be paid to protecting the controls, switches, etc. Tape a note to top of the unit describing the malfunction, and instructions for return. We will pay one-way return shipping costs on any in-warranty repair.

Because of specially selected components in this product, field repairs are not authorized during the warranty period, and attempts to perform repairs may invalidate the warranty.

5.3 SERVICE ADJUSTMENTS

These controls have been carefully set at the factory and should not require adjustments except after service work.

5.3.1 COMMON MODE BALANCE

The internal trimpot R1 affects the COMMON MODE BALANCE. If a check or an adjustment is necessary the following procedure should be followed:

Connect the  $\pm$  and COM input terminals together and apply an input signal between this connection and the GND terminal (100 Hz, 3 V rms).



With EQ OUT, measure the signal with an AC VTVM or DVM across the output terminals of the Model 535. Adjust the trimpot R1 for a minimum reading, switching the voltmeter to more sensitive ranges as required. It should be possible to obtain a reading below 0.03 volts (40 dB down).

#### 5.3.2. OFFSET ADJUSTMENT

The internal trimpot R7 affects this adjustment. It should only be necessary to change the factory setting if IC 1 or IC 5 is replaced. The adjustment is correct when the DC output of IC 1C is the same as the offset voltage at the input of IC 5A. No "click" will be generated when the EQ switch is operated, if this adjustment is correct.

NOTE: If the offset control is severely misadjusted, large voltage pulses are generated in the equalizer when the EQ switch is operated. This could overload or damage unprotected equipment which may be connected to the output of the Model 535. UREI cannot be responsible for consequential damages due to misadjustment of this control.

#### PREFERRED METHOD

With no input signal applied, set the EQ switch to the "IN" position. Measure the DC offset voltage of IC 5A (brown wire at the EQ switch) and adjust R7 until the output of IC 1C measures the same value (red wire at the EQ switch). The range of the adjustment is approximately  $\pm 30$  mV.

#### ALTERNATE METHOD

Connect the output terminals of the Model 535 to a high gain amplifier and loudspeaker. With no input signal applied switch the EQ IN and OUT.

Listen to the loudspeakers and adjust R7 for minimum audible "click" while operating the EQ switch.

#### 5.4. CLEANING

The front panel of the 535 may be cleaned with a non-abrasive cleanser such as "Formula 409" or "Fantastic" applied with a soft clean cloth. Additional protection of the anodized panel can be afforded through a light application of a spray wax preparation such as "Pledge." Never spray the panel directly, as the cleanser or wax may adversely affect the lubrication of the slide pots.

## 5.5 ON OP AMPS

The Model 535 Graphic Equalizer makes extensive use of integrated circuit operational amplifiers (IC op amps). During the last several years, much research and development work has been done by the semi-conductor manufacturers to improve their products, and more is anticipated. We expect that better op amps at lower cost will be available as this development work continues. At the time of the design of the Model 535, we anticipated this and have made every effort to design the circuit so that as improved parts become available they may be incorporated into the Model 535 with little, if any, modification. We also realize that occasionally an IC will fail. For this reason, the table below lists a number of different operational amplifiers which will function as direct, pin-for-pin replacements for the op amps in the 535. For one reason or another, they may not function as well as the op amps originally supplied with this unit, but for emergency repairs, if the original types are not available, these will get the instrument back into service.

|                    | <u>MODEL or TYPE</u> | <u>MANUFACTURER</u>    |
|--------------------|----------------------|------------------------|
| ORIGINAL . . .     | HA 4741-5 . . .      | HARRIS                 |
| REPLACEMENTS . . . | HA 4741-5 . . .      | RAYTHEON               |
|                    | TL 074 . . .         | TEXAS INSTRUMENTS      |
|                    | TL 084 . . .         | TEXAS INSTRUMENTS      |
|                    | RC 4156 . . .        | RAYTHEON               |
|                    | LM 347 . . .         | NATIONAL SEMICONDUCTOR |

All of the above "replacement" op amps should be considered interim replacements until the correct "original" device can be obtained and substituted.

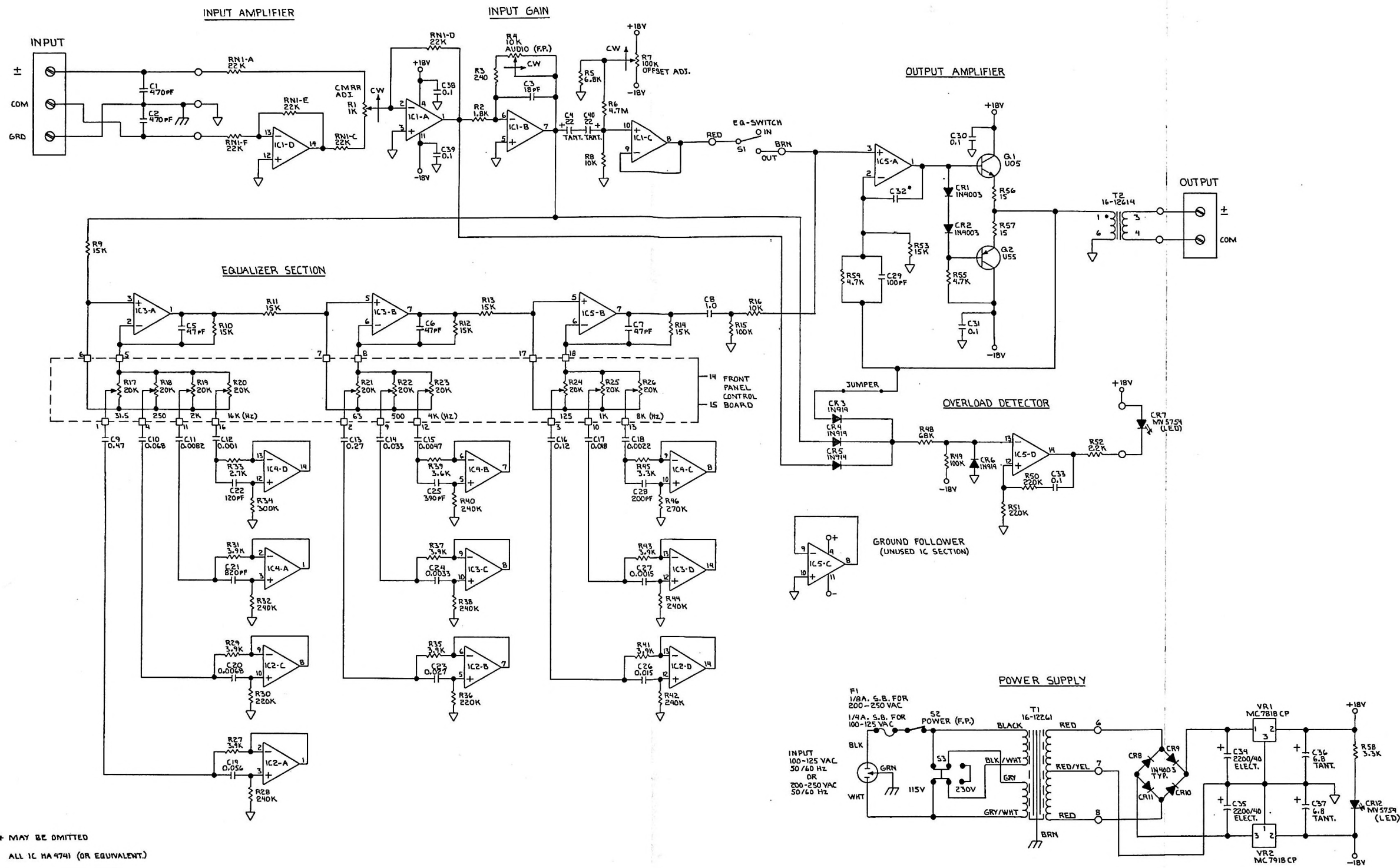

- 10. \* MAY BE OMITTED
- 9. ALL IC HA 4741 (OR EQUIVALENT)
- 8.  $\perp$  INDICATES CHASSIS GROUND.
- 7.  $\nabla$  INDICATES CIRCUIT GROUND
- 6.  $\rightarrow$  INDICATES CLOCKWISE ROTATION.
- 5. (F.P.) INDICATES FRONT PANEL CONTROL.
- 4.  $\circ$  INDICATES WIRE TERMINATION ON P.C. BOARD.
- 3.  $\square$  INDICATES P.C. CONNECTION.
- 2. CAPACITOR VALUES ARE IN MICROFARADS
- 1. RESISTOR VALUES ARE IN OHMS  $\pm$  5% 1/2W

**NOTE:**  
 COMPONENTS SHOWN ARE FOR CHANNEL "A"  
 FOR CHANNEL "B" ADD PREFIX "100" TO COMPONENT IDENTIFICATION NUMBER, (R42 BECOMES R142), EXCEPTION: POWER SUPPLY WHICH SERVES BOTH CHANNELS.

NOTES: UNLESS OTHERWISE SPECIFIED.

|   |           |                |
|---|-----------|----------------|
| <b>SCHEMATIC</b><br>GRAPHIC EQUALIZER     |           |                |
| SIZE                                      | MODEL NO. | DRAWING NO.    |
| R   | 535       | 13129 B        |
| REV B PER ECO-0535-002 EFFECTIVE SER# 251 |           | DATE 4-13-79   |
| REV A CHANGE TO BE USE ON 535 ONLY        |           | DR: R.P. MARIN |
| SHEET 1 OF 1                              |           |                |

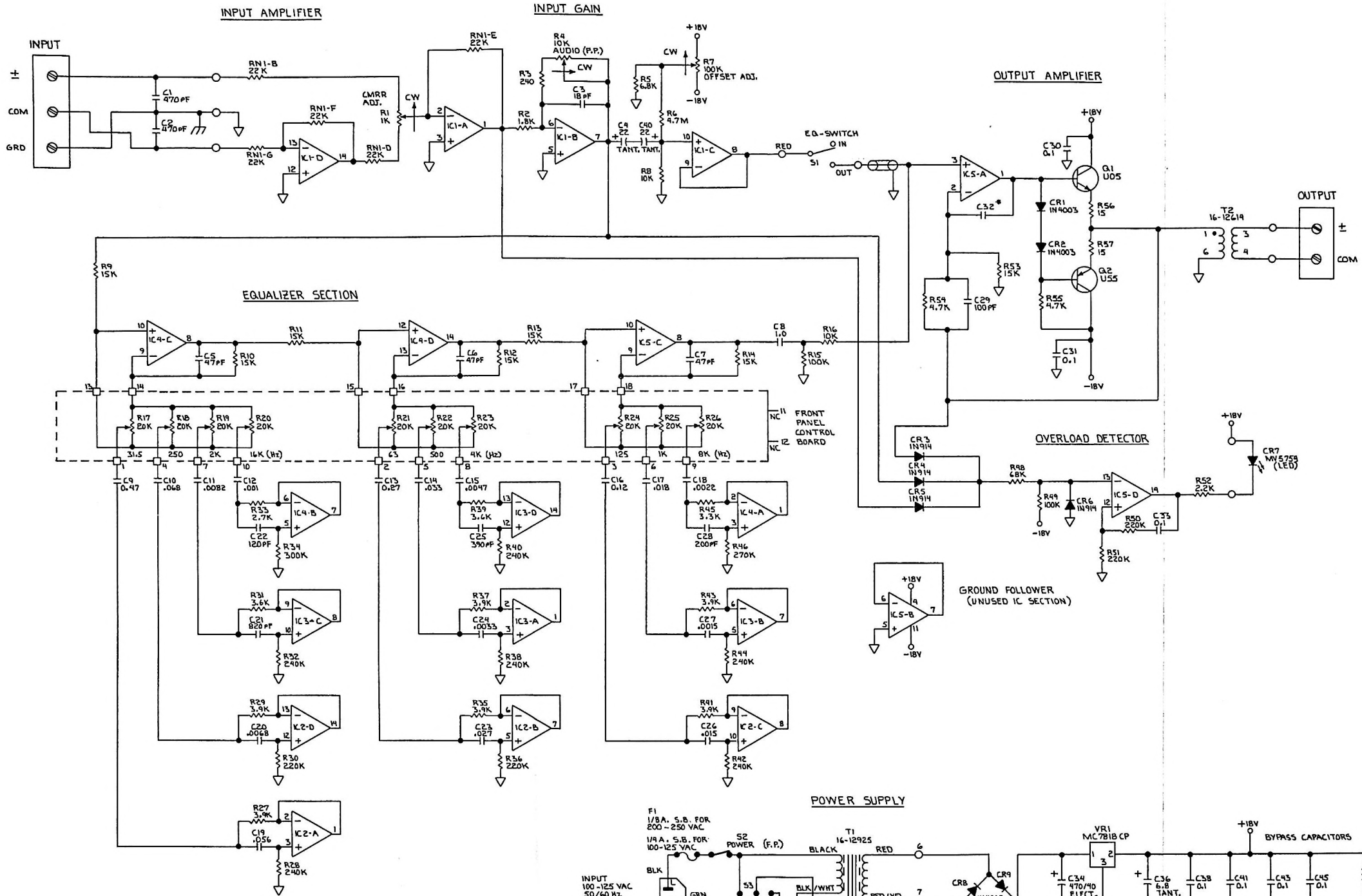

- 10 \* MAY BE OMITTED.
9. ALL IC HA4741 (OR EQUIVALENT).
8.  $\text{///}$  INDICATES CHASSIS GROUND.
7.  $\nabla$  INDICATES CIRCUIT GROUND.
6.  $\rightarrow$  INDICATES CLOCKWISE ROTATION.
- 5.(F.P.) INDICATES FRONT PANEL CONTROL.
4.  $\circ$  INDICATES WIRE TERMINATION ON P.C. BOARD.
3.  $\square$  INDICATES P.C. CONNECTION.
2. CAPACITOR VALUES ARE IN MICROFARADS.
1. RESISTOR VALUES ARE IN OHMS  $\pm 5\%$  1/2W

NOTES: UNLESS OTHERWISE SPECIFIED.

SCHMATIC  
GRAPHIC EQUALIZER

|      |           |             |
|------|-----------|-------------|
| SIZE | MODEL NO. | DRAWING NO. |
| R    | 533       | 13186A      |

In order to insure registration of your instrument for warranty purposes, return this card within 10 days of purchase. (No postage necessary, if mailed in the U.S.)

Name \_\_\_\_\_ Model \_\_\_\_\_

Address \_\_\_\_\_ Serial \_\_\_\_\_

City \_\_\_\_\_ State \_\_\_\_\_

Distributor \_\_\_\_\_

Date Purchased \_\_\_\_\_

Installed by: Dealer  Systems Mfg.  Owner  Other

How did you find out about this equip.? \_\_\_\_\_

Did the Dealer check unit out in his shop? Yes  No

(Detach Here)

## Warranty

URE products are warranted by URE against defective material and/or workmanship for a period of one year from date of shipment.

Warranty is voided by misuse or by maintenance or installation practices not covered in our published instructions or by use of parts other than those supplied by URE.

Warranty does not apply to expendable items such as batteries, tubes, lamps, fuses, etc. Products covered by this warranty will be repaired or replaced at our option F.O.B. factory, URE assumes no responsibility for indirect or consequential damages or loss of any nature in connection with equipment sold by us.

Warranty is not valid unless registration card is mailed to URE.

The logo for United Recording Electronic Industries, consisting of the letters 'URE' in a stylized, bold, sans-serif font.

UNITED RECORDING ELECTRONIC INDUSTRIES



**BUSINESS REPLY MAIL**  
FIRST CLASS PERMIT NO. 191, SUN VALLEY, CALIFORNIA

**URi**

**8460 San Fernando Rd.**

**Sun Valley, Ca. 91352**

**U.S.A.**

