

OPERATING INSTRUCTIONS

MODEL BL-40
BROADCAST LIMITER
INSTRUCTION MANUAL

Universal Audio

TELETRONIX

products of

Urei

UNITED RECORDING ELECTRONICS INDUSTRIES

1922 VALERIO STREET, NO. HOLLYWOOD, CALIFORNIA 91605 TEL. (213) 764-1500

8460 San Fernando

213-767-1000

Fernando Road, Sun Valley, CA 91352

MODEL BL-40
BROADCAST LIMITER

INSTRUCTION MANUAL

Manufactured in USA by

UNITED RECORDING ELECTRONICS INDUSTRIES

11922 Valerio Street
North Hollywood, California 91605
Telephone: (213) 764-1500

Printed in U.S.A.

TABLE OF CONTENTS

		<u>Page No.</u>
SECTION I	GENERAL INFORMATION	1
SECTION II	TECHNICAL SPECIFICATIONS	2
SECTION III	INSTALLATION	4
SECTION IV	OPERATION	6
SECTION V	THEORY OF OPERATION	7
SECTION VI	TROUBLESHOOTING	12
SECTION VII	RECALIBRATION	15
SECTION VIII	FIELD MODIFICATIONS	19
SECTION IX	PARTS LIST	20
SECTION X	RECOMMENDED SPARES	24
SECTION XI	DRAWINGS	

SECTION I

GENERAL INFORMATION

1-1. The BL-40 Broadcast Limiter has been designed to fill the needs of the AM broadcaster who desires a constant high modulation index with absolute control of transmitter overmodulation. The design goal is satisfied without resorting to the use of clipping, magic boxes, or secret circuits. The limiter is straightforward and easy to understand, operate, and service.

Signal conditioning is accomplished in three steps. The first processor controls signal level by measuring RMS content and adjusting gain to produce constant power. This section of the limiter uses a patented (U.S. Patent 3,258,707) optical attenuator which has proven to be an ideal device for RMS signal limiting.

The second major section compares the amplitude of the positive and negative signal peaks and corrects the signal phase to produce maximum upward modulation. The pilot light on the front panel indicates relative phase of the input and output signals of the BL-40. The indicator is a two color light emitting diode array. Green indicates in-phase input and output. Red indicates a 180° phase difference between the input and output signals.

The third signal conditioner is a Field Effect peak limiter designed to tightly control peak-to-peak amplitude without introducing the distortion commonly associated with simple peak limiters (clippers).

Attack and release times of the limiter section are very short, allowing the largest possible average output consistent with low distortion. Attack time is typically 5 microseconds and release time is typically 100 milliseconds. Ripple suppression is used to allow fast limiting release without low frequency distortion.

The results are quite beyond the performance capability of past limiting schemes, allowing excellent control, high average level, and minimum waveform distortion of the output signal.

SECTION II

TECHNICAL SPECIFICATIONS

INPUT IMPEDANCE	: 600 ohms bridged-T input control. Floating, transformer isolated.
OUTPUT LOAD IMPEDANCE	: Designed to work into 600 ohm load. Output transformer isolated.
INPUT LEVEL	: -25dBm to +25 dBm for 5dB limiting.
MAXIMUM OUTPUT LEVEL	: +27dBm.
GAIN	: 70dB with all controls at maximum.
FREQUENCY RESPONSE	: +0, -.8dB 30 Hz - 15 kHz.
DISTORTION (No limiting)	: Less than .5% T.H.D. 30 Hz to 15 kHz, at +24 dBm output.
DISTORTION (5dB RMS, 5dB peak limiting)	: Less than 3% T.H.D. 50 Hz to 15 kHz at +24dBm output.
SIGNAL-TO-NOISE RATIO	: Better than 70dB at threshold of RMS limiting. Equivalent input noise less than -110dBm.
ATTACK TIME, RMS SECTION	: Signal dependent: 1 millisecond to 50 milliseconds.
RELEASE TIME, RMS SECTION	: Signal dependent: 50 milliseconds to 2 seconds depending on duration of compression.
ATTACK TIME, PEAK SECTION	: 5 micro-seconds for 10dB limiting.
RELEASE TIME, PEAK SECTION	: 100 milliseconds.
COMPRESSION RATIO	: Greater than 80 : 1.
METERING	: 3 Separate meters for: RMS limiting Peak limiting Output level
EXTERNAL CONNECTIONS	: Barrier strip on rear with input, output, and monitor feed.

- CONTROLS : Input Level, Output Level, Output Meter Calibration, Peak Limiting, Asymmetrical Peak Limiting, By-pass Switch, and Power Switch.
- POWER REQUIREMENTS : 110-120 VAC 50-60 Hz 10 watts or 220-240 VAC 50-60 Hz 10 watts.
- TEMPERATURE : Maximum ambient temperature +50°C (+122°F).
- RF SUPPRESSION : Capable of operating in strong RF fields. (Field tested 150 feet from 50 KW array).
- FINISH : Clear anodized brushed aluminum front panel. Cadmium plated chassis.
- DIMENSIONS: : 3½" Vertical, for mounting in standard 19" rack. Depth behind panel 8".
- WEIGHT : 11 pounds.
- SHIPPING WEIGHT : 16 pounds.

SECTION III

INSTALLATION

3-1. UNPACKING AND INSPECTION. Carefully examine the contents of the shipping carton for any sign of physical damage which could have occurred in transit. Though your BL-40 was carefully packed at the factory, and the container was designed to protect the unit through rough handling, accidents do happen.

IF DAMAGE IS EVIDENT, DO NOT DESTROY ANY OF THE PACKING MATERIAL OR CARTON, AND IMMEDIATELY NOTIFY THE CARRIER OF A POSSIBLE CLAIM FOR DAMAGE. SHIPPING DAMAGE CLAIMS MUST BE MADE BY THE CONSIGNEE.

Besides the BL-40 unit itself, you should verify that the shipment included the following:

- a. This instruction manual.
- b. A two-part warranty card, bearing the same serial number as the unit.
- c. If ordered, the accessory spares kit.
(Check your packing slip and purchase order to verify this option.)

Complete the Warranty Card, and mail the return portion immediately to activate your one-year warranty. (No postage required.)

3-2. ENVIRONMENTAL CONSIDERATIONS. The Model BL-40 will operate satisfactorily over a wide range of ambient temperatures, from 0°C to +50°C (32°F to +122°F.) If included in an equipment rack with high heat producing equipment, such as power amplifiers, adequate ventilation should be provided, however, to prolong life of components. Also, while coils and other circuitry susceptible to hum pickup are adequately shielded from moderate electromagnetic fields, installation should be planned to avoid mounting the BL-40 immediately adjacent to large power transformers, motors, etc.

To comply with existing Electrical Codes, the BL-40 is supplied with a three-wire AC power cord, the grounding pin of which is connected to the chassis. In some installations, this may create ground-loop problems, if a significant potential difference exists between a grounded metal enclosure in which the chassis is installed, and the AC conduit ground. If hum is experienced, check for this possibility by using a 3-wire to 2-wire adaptor at the power receptacle, ungrounding the AC plug.

3-3. POWERING. The Model BL-40 may be operated from either 110-120 VAC or 220-240 VAC mains supply, 50 or 60 Hz single phase, depending upon the position of the power transformer input switch. This is a recessed slide switch, which is located adjacent to the fuse post and line cord entry on the rear of the chassis. Unless a tag on the line cord specified otherwise, your unit was delivered ready for operation from 110-120 VAC mains. Verify this before applying power to the unit by observing that the number 115 appears near the bottom of the slide-switch window. The AC fuse should be 1/8A, slo-blo.

To change for operation from 220-240 VAC, use a small screwdriver in the horizontal slot of the slide-switch. Push down firmly until the number 230 appears at the top of the window. (To change for 110-120 VAC, push up.) For 220-240 VAC operation, the line fuse should be changed to 1/16A slo-blo, for proper protection.

3-4. EXTERNAL CONNECTIONS. During initial setup the input, peak limiting and output controls should be set to minimum (CCW) to avoid overloading the subsequent amplifiers.

Input and output signal pair wires should be connected as indicated on the rear chassis above the terminal strip, following standard practices.

If the output is to be connected to a high-impedance circuit, a 620 ohm resistor (1/2 watt) should be shunted across the † and COM. output terminals.

The monitor feed on the rear terminal strip is 600 ohms single ended. The level is 10dB below the output if bridged and 16dB below the output if terminated. Termination is optional.

SECTION IV

OPERATION

4-1. GENERAL. The BL-40 has been designed for very easy adjustment. The main operating controls are located behind the removable security cover to the right of the meters. Before applying power set the controls as follows:

INPUT	:	Counterclockwise
PEAK LIMITING	:	Counterclockwise
OUTPUT	:	Counterclockwise
POSITIVE THRESHOLD	:	Counterclockwise
METER ADJUST	:	Clockwise

Apply power and check zero readings on RMS meter and Peak meter. If necessary adjust for accurate "0"dB readings with the RMS zero or Peak zero controls.

Next, apply input signal and advance input control clockwise until RMS meter indicates 3 to 5dB of gain reduction.

Advance peak limiting until 3 to 5dB of peak limiting is indicated.

Advance output control for 100% modulation of transmitter.

If positive asymmetry is to be used, advance the positive threshold control for the desired amount of positive overmodulation.

Adjust the output meter sensitivity to read zero on signal peaks.

4.2. PROOF OF PERFORMANCE TESTS. For proof of performance testing the BL-40 should be left in the limit mode to avoid bypassing circuitry within the limiter. Controls may be left set as in normal limiting operation and the input signal level adjusted downward until no gain reduction of the test signal is indicated. Output level may then be adjusted with the output level control for the desired modulation percentage.

4-3. PHASE OPTIMIZER. The sensitivity of your BL-40's Phase Optimizer circuit has been factory set for best operation on a wide range of program material. Should it be desired to increase or decrease sensitivity, or to completely defeat the operation of this circuit, see Section VIII (Field Modifications), Paragraphs 8.5 and 8.6.

SECTION V

THEORY OF OPERATION

For purposes of this section the BL-40 will be divided into circuit blocks and each treated individually.

5-1. POWER SUPPLY. The BL-40 power supply consists of the power transformer T4, the rectifiers and filter capacitors, and two regulator circuits supplying plus and minus 18 volts referenced to chassis ground. Rectification of the secondary voltage of the power transformer T4 is through silicon diodes CR11, CR12, CR13, and CR14. CR12 and CR14 supply positive voltage for the positive side of the supply. CR11 and CR13 supply negative voltage for the negative side of the supply. Capacitors C48 and C49 are filter capacitors for the negative and positive sides of the supply respectively. The negative and positive regulators are identical with the exception of the manner in which their reference voltages are derived. Reference voltage for the positive supply is furnished from a 10 volt zener diode CR18. Reference voltage for the negative supply is derived from the positive supply. This allows one voltage adjustment and precise tracking between the two power supplies.

Operation of the positive supply will be described first. Unregulated supply voltage is applied to the collector of Q12, which is connected as an emitter follower. The base of Q12 is driven from the output of operational amplifier IC 8. The positive input (pin 3) of IC 8 is connected to a +10 volt reference source. Start-up for the reference source is supplied through R76. After the power supply voltage comes up, CR15 conducts output voltage to the junction of R76 and R77 supplying a stable current source to the zener diode CR18. The output of the supply is sampled by the voltage divider R78, R79, and R82. R79 is the power supply voltage adjustment potentiometer. The output of this divider is connected to the inverting input (pin 2) of IC 8 and compared to the +10 volt reference voltage. If the voltage at the wiper of R79 differs from +10 volts, the output of IC 8 drives the base of Q12 in the proper direction to correct the output voltage error. Transistor Q13 samples the voltage drop across the resistor R83. If the power supply is inadvertently short-circuited transistor Q13 conducts and shunts base current away from transistor Q12 and limits the output current of the power supply. Silicon diodes CR16 and CR17 are connected across the outputs of the power supplies to protect against inadvertent power supply output reversal in the event that the plus and the minus supplies are shorted together. Capacitors C52 and C53 supply high frequency filtering and lower the high frequency output impedances of the regulated supplies.

Two 39K precision resistors R89 and R90 are connected to the outputs of the plus and minus supplies respectively. If the plus and minus supplies are equal, the junction of the two resistors will be at 0 volts

with respect to ground. The positive input (pin 3) of IC 9 is connected to ground. The negative input (pin 2) connects to the junction of R89 and R90 and compares the voltage of that junction against ground. If the voltage of the junction varies from 0 volts the output of IC 9 drives the base of Q15 in a manner to correct the error on the negative regulator output and makes the output voltages equal. Transistor Q14 is short-circuit protection for the negative supply and functions in a similar manner to Q13 in the positive supply.

Power supply voltage adjustments should not be made unless the supply voltage has drifted more than half a volt. If power supply voltage is adjusted other adjustments in the limiter will be affected and complete recalibration will be required. The power supply voltage tolerance is 18 volts plus or minus .5 volts. The plus and minus supply should match within .2 volts. In the event that power supply troubleshooting is required, it should be remembered that operation of the negative power supply is dependent on the positive power supply for its reference voltage. Therefore, if the positive power supply is defective the output of the negative power supply will be wrong. If only the negative power is defective the positive power supply will not be affected.

5-2. INPUT ATTENUATOR, INPUT AMPLIFIER, AND RMS LIMITING CIRCUIT.
The input control is a standard 600 ohm bridged-T type attenuator, connected between the input terminals to the limiter and the primary winding of the input transformer. The input transformer supplies approximately 14dB of gain ahead of the input amplifier stage. An additional 14dB of gain is supplied by IC 1 making the total gain from input terminals to the input of the RMS limiter 28dB. C1, C2, and C3 are in the circuit for RF suppression. The signal from IC 1 is coupled through C8, a DC blocking capacitor, and then through resistors R11 and R15 to the input of the voltage follower IC 3. The input of IC 3 is shunted to ground by a light dependent resistor which is part of the optical attenuator assembly. Variations in light intensity falling on the light dependent resistor control the input level to the follower. A sample of the input signal to this stage is amplified by IC 2 and transistors Q2 and Q3 then stepped up 10 : 1 through transformer T2. The output of transformer T2 drives an electro-luminescent panel which is in contact with the light dependent resistors in the optical attenuator. As increasing input signal tries to increase the output of the gain reduction amplifier, made up of IC 2, Q2, and Q3, the increased light level results in reduction of the resistance of the light dependent resistors. This causes increased voltage division at the input of the follower IC 3 and effectively regulates the signal amplitude.

The field effect transistor Q1 is wired as a constant current source and drives constant current through an identical light dependent resistor which is also in contact with the electro-luminescent panel in the optical attenuator. The RMS limiting meter is connected to the junction of the second light dependent resistor and the output of the

constant current source and loads the junction with approximately 15K. (33K in some earlier units). In this way the DC voltage developed at the end of the 15K resistor R8, is a mirror of the AC voltage attenuation at the input of the follower. Changes in resistance of the light dependent resistors will cause a change in gain of the amplifying system and simultaneously cause a change in DC level going to the RMS limiting meter. The RMS limiting meter, therefore, indicates the amount of limiting directly in decibels.

5-3. PHASE OPTIMIZER. The U.R.E.I, phase optimizer operates by comparing positive and negative peaks from the output of IC 3 and reversing phase, as required, to the input of the peak limiter. Operation is as follows:

Signal from IC 3 is amplified 10 : 1 by IC 11 and fed to D2 and D3. D2 and C62 function as a positive peak detector (with respect to IC 11 output terminal). D3 and C63 perform the same function for negative peaks. R103 and R104 combine the peak rectifier outputs and drive the input of IC 12. If imbalance between positive and negative peaks exists the input of IC 12 is driven in the direction of the imbalance.

IC 12 is a comparator with 0 volts as a reference (through R105). Positive feedback is brought around to the input of the comparator through R107. The degree of positive feedback is adjusted by R108. The positive feedback causes the output of IC 12 to toggle immediately when the input threshold is exceeded. The output of IC 12 has two stable states: all the way positive or all the way negative. The feedback tends to lock the output in one state or the other. For example, if the output is fully positive it will tend to remain there unless sufficient peak detector imbalance causes it to switch. This feedback avoids "hunting" for the proper phase when the imbalance is small. At maximum sensitivity an imbalance of .1dB will cause the output of IC 12 to change states. At minimum sensitivity an imbalance of 10.0dB will be required to switch states. The control is factory set to trip on a 1.0dB (10%) imbalance. This setting, it seems, is a good compromise between adequate sensitivity and unwanted hunting.

The voltage controlled phase inverter consists of Q16, IC 10, and associated components. In the non-inverting (GREEN) state Q16 is off because the output of IC 12 is low. Under this circumstance IC 10 functions as a unity gain follower and its output is in phase with its input. If negative signal peaks become greater than positive signal peaks IC 12 changes state (RED) and saturates Q16, grounding the non-inverting input of IC 10. IC 10 then functions as a unity gain inverter with an output equal in amplitude, but 180° out of phase with its input. Thus the largest signal peaks are always polarized positive at the output of IC 10. The output of IC 10 drives the peak limiter.

5-4. PEAK LIMITING CIRCUIT. The output of switchable inverter IC 10 is connected to the input of a voltage divider made up of R94,

R75, and R20, to reduce the signal level to the input of the peak limiter to a value manageable by the field effect transistor, Q4. Resistor R21 in combination with the field effect transistor Q4 forms a simple voltage divider. The conductance of Q4 is modulated by a positive DC signal derived from the output of the peak limiting gain-reduction-amplifier. Signal across the FET is sampled by amplifier IC 4 and amplified approximately 3dB before being applied to the output level control and the input of the peak gain reduction amplifiers.

The peak gain reduction circuit consists of two amplifiers IC 5 and IC 6. These amplifiers have been chosen for excellent high frequency response and stability to allow very fast attack time in the peak limiter. IC 6 is connected as a unity gain follower with its output half-wave rectified by CR6. The output of CR6 is driven through R91 and R37 in series to the emitter of Q5. IC 5 is a unity gain inverter, the output of which is rectified by CR5 and applied through a 680 ohm resistor R38, also to the emitter of Q5. This circuit allows separate gain control of the positive and negative excursions of the input waveform. The 250 ohm potentiometer R37 can be adjusted to reduce the sensitivity of the emitter of Q5 to signals from CR6, the positive peak rectifier, allowing positive over-modulation. The transistor Q5 is connected as a common base amplifier with excessive forced emitter current. The operation of this circuit is a bit unusual and will therefore be described in detail: R43, a 2.2K resistor forces approximately 7.9 mA into the emitter of Q5. Only 4.8 mA is required to reduce the collector voltage of Q5 to -.6 volts. In the quiescent condition the excess 3.1 mA of emitter current flows through CR19 and R39 to ground. IC 5 and IC 6 are capable of sinking excess emitter current away from Q5 through CR5, CR6, R38, R91 and R37. The values of these components are chosen so that if the peak signal amplitude exceeds +2.5 volts at the output of either IC 5 or IC 6, transistor Q5 will be driven out of conduction producing a positive going voltage pulse at its collector. The gain of Q5 is quite high and a relatively large pulse will be produced with a very slight increase in signal above 2.5 volts peak. R37 allows adjustment of the threshold for positive signal peaks from IC 6 so that asymmetry may be obtained. The point at which Q5 begins to be switched out of conduction by signal peaks is the threshold of peak limiting.

Transistor Q6 is connected as an emitter follower to transform the 3900 ohm output impedance of the pulse amplifier Q5 to a very low value in order to allow rapid changing of C35, the peak storage capacitor. R47 and R45 limit charging current for C35 to protect Q6 from damage. A DC voltage is developed across C35 due to the positive going pulses from the emitter of Q6 when the peak reduction threshold is exceeded. This voltage is connected to the gate of Q4 through R32 and will drive Q4 into conduction to control signal amplitude. R29, R30, and R31 are a linearizing circuit to reduce signal distortion caused by non-linearity in the channel resistance of Q4. C25, C26, and C27 are speedup capacitors to avoid delay in the correction signals to the gate of Q4.

Peak limiting release is controlled by a feed forward circuit consisting of CR7, R48, R42, R44, and C54. The voltage on C54 is nearly equal to that on C35 during limiting so the discharge resistor R44 is effectively bootstrapped out of the circuit during long term limiting of constant amplitude signals. The time constant in this part of the circuit is very short, however, and if the signal being limited drops below threshold the limiter will release very quickly. Use of this circuit allows fast release of limiting without distortion of low frequency signals, due to partial release between half-cycles.

A meter amplifier IC 7 monitors the voltage fed to the gate of Q4 and causes an indication of the amount of peak limiting on the peak limiting meter.

5-5. OUTPUT AMPLIFIER. The output amplifier is a garden variety complementary output amplifier with feedback to the emitter of the input transistor Q7. Special attention was paid to phase shift which can, if uncontrolled, undo the peak limiting of low frequency signals and allow overmodulation. The output transformer is designed to be terminated with 600 ohms. A resistor should be added across the output to load the BL-40 properly if the transmitter has an input impedance greater than 600 ohms. If the input impedance of the modulator is less than 600 ohms, build-out resistors should be added or a stepdown transformer should be used.

SECTION VI

TROUBLE SHOOTING

If trouble shooting the BL-40 is necessary the following equipment should be available:

1. Oscilloscope
2. Audio signal generator
3. Digital voltmeter
4. Audio voltmeter
5. 1 each - LM301A, LM318

6-1. POWER SUPPLY. The most probable power supply fault would be failure of an I.C. If spare I.C.'s are available try substitution while monitoring supply busses. If no spares are available use IC 1 or IC 3 for a substitute. The reference zener may be checked by removing IC 8 and IC 9, to avoid loading, and measuring the voltage at CR18 with a high impedance voltmeter. The voltage should be between +9 and +11 volts.

The least likely failure would be the pass transistor Q12 as it is running at about 1/10 of its rated power. If the current limiter transistor Q13 is suspected it may simply be removed since the power supply will operate without it.

If the positive supply is O.K. but the negative supply is not, substitute IC 9. Q14 is not likely to fail but should be substituted if suspected.

Naturally, power buss overloading or short circuits will cause low supply voltage. Two jumpers are located near the power supply which may be removed to see if the fault is due to excessive loading. If this proves to be the case a crude but effective method for finding the overload is to reconnect, turn the unit on and see what gets hot. Be careful! I.C.'s can get very hot.

If the smoke test is successful, you have found the problem area and should jump to the section of this procedure which is relevant. If signal path problems exist, tracing a signal through the limiter is the best method for finding a problem.

A great deal of the circuitry can be eliminated by checking to see if the limiter passes signal when the front panel switch is in bypass. If the limiter passes signal in bypass the input amplifier and the output amplifier are O.K. and the trouble lies between the output of IC 1 and the output level control. Connect the signal source to the input, set the level of the generator to -40dBm and frequency to 1 kHz. Using a scope probe simply trace through the electronics until the point is found where signal disappears. The signal path is described below in some detail to facilitate tracing.

6-2. INPUT AMPLIFIER. Signal passes through the input attenuator R3 to the primary of input transformer T1. Gain through the input transformer should be 14dB. From the secondary of T1, signal passes through IC 1. Gain of IC 1 is set at 15dB.

6-3. RMS LIMITER. From the output of IC 1 the signal path is through R11, C8, and R15 to the input of IC 3 which has no gain. The output of IC 3 should be the same as the output of IC 1 if the optical attenuator and IC 2 are removed. If the optical attenuator loads the input of IC 3 when IC 2 is not in the circuit, the attenuator is defective. If IC 2 loads the input of IC 3, IC 2 is defective. If signal passes to the output of IC 3, RMS limiting should operate normally, if IC 2, Q2, Q3, T2, and the optical attenuator are O.K. T2 may be checked by observing the voltage step up from the 80 uF capacitor C16 to pin 3 of the optical attenuator socket. This step up should be 1 to 10 (20dB).

6-4. AUTOMATIC PHASE INVERTER. This circuit consists of three major parts.

The first is a peak rectifier and storage capacitor.
The second is a voltage comparator and switch.
The third is the voltage actuated phase inverter.

IC 11 amplifies signal from IC 3 about 21dB. The output of IC 11 drives two half-wave rectifiers CR2 and CR3. With a sinusoidal input signal the voltages at the end of C62 and C63 should be equal but of opposite sign. Short circuiting C63 should force the comparator to the GREEN state. In this condition the output of IC 12 will be 15 to 18 volts negative with respect to ground and the front panel indicator will be GREEN. Likewise shorting C63 will drive the output of IC 12 to the high state and the LED will be RED. Sensitivity of the comparator to positive-negative imbalance may be adjusted with R108.

If R108 is clockwise the comparator is extremely sensitive and phase reversals will occur with very slight imbalance and quite frequently. If fully counterclockwise the comparator is quite insensitive and phase reversals will occur most infrequently, if at all.

DC control voltage from the output of IC 12 drives the gate of the F.E.T. switch through R111. If the gate is driven positive (RED state) the + input of IC 10 is shorted to ground and IC 10 functions as a phase inverter. If the gate is driven negative (GREEN state) the F.E.T. is an open circuit and IC 10 acts as a non-inverting amplifier. In both states the amplifier has unity gain.

If it is desired to defeat the automatic phase inverter simply remove IC 11. The power up clear circuit C59, R116, R117, and CR1 will guarantee the GREEN state (non-inverting).

6-5. PEAK LIMITER. Signal from IC 10 passes through the peak limiting control R75 then through R21, C18 and C20 to the input of IC 4. IC 4 should have a voltage amplification of 37dB. IC 5 and IC 6 are unity gain. The outputs of IC 5 and IC 6 should match the output of IC 4. IC 5 and IC 6 look like the others but are not the same type. IC 5 is an LM 318. IC 6 is either an LM 318A in early units or an LM 310A in later units. LM 301A's will not work.

The threshold amplifier can be checked by grounding the emitter of Q5. The collector of Q5 should rise to over 16 volts and the emitter of Q6 should follow. If signal passing through the limiter drops at least 30dB, the field effect transistor Q4 is O.K.

6-6. OUTPUT AMPLIFIER. Signal from the output control, R46, connects through C36 and R49 to the base of Q7. The emitter of Q7 should be at around -0.5 to -0.6 volts DC. The collector of Q7 should be at about +16 volts DC. The collectors of Q8 and Q9 should be near 0 volts. The emitters of the output transistors Q10 and Q11 should be at -0.5 to -0.7 volts DC. If these DC potentials are correct signal should pass through the output stage.

SECTION VII
RECALIBRATION

If recalibration seems necessary the test procedure below should be carefully followed:

7-1. INITIAL SETTINGS.

From front panel:

Input Level	R3	CCW
Limiting	R75	CCW
Output	R46	CW
Positive Threshold	R37	CCW (100%)
Output Meter	R62	CCW (+4)
Mode Switch		to: Limit

Inside chassis:

T4C	Removed	
"Q"-bias	R24	CCW
Peak Balance	R33	Midpoint
Peak Meter Tracking	R67	Midpoint

7-2. ADJUSTMENTS.

7-2.1 POWER SUPPLY. Connect the unit to the AC-power line and connect the test cables to input and output. Switch power ON.

Pilot Light should be ON.

Adjust R79 in the power supply section for ± 18.0 volts. Tracking between positive and negative supply must be within 0.2 volt.

NOTE: If no regulated voltage is available at the output of the power supply a short in the subsequent circuitry may cause the current protection to shut the power supply down. Two jumper wires (positive and negative voltage) may be disconnected to determine whether the power supply functions properly.

- 7-2.2. ZERO ADJUSTMENT OF METERS. Remove IC 5, IC 6, and T4C. From the front panel adjust:
- a. RMS-Zero (R12) until RMS meter reads zero dB.
 - b. Peak-Zero (R66) until Peak Limiting Meter reads zero dB.
- 7-2.3. "Q"-BIAS ADJUSTMENT. Remove IC 5, IC 6, and T4C. Apply signal to the input (1 kHz, - 30dBm).
- Turn Input control CW until the Output Level Meter reads +1dB.
- Adjust "Q"-Bias control CW until the Output drops to 0dB.
- This causes FET Q4 to be at the threshold of conduction.
- 7-2.4. PEAK LIMITING TRACKING. Remove IC 5, IC 6, and T4C. Connect a high resistance (approximately 4.7 megs) from B+ to the emitter of Q6. This will cause limiting and is indicated on both the Output Meter and the Peak Limiting Meter. Select a resistance which will give about -5dB reading on the Output Meter.
- Since the adjustments of Peak-zero (R66) and Limiting-tracking (R67) interact, the following adjustments have to be repeated alternately several times until both zero and tracking are achieved.
- a. With DC connected adjust R67 until both meters read the same reduction.
 - b. Disconnect DC and readjust R66 for a zero reading on the Peak Limiting Meter.
 - c. Repeat "a" and "b" until both "0" and tracking are satisfactory.
- 7-2.5. PEAK BALANCE ADJUSTMENT. Insert IC 5 and IC 6. Apply an input signal and turn the Input control CW until some peak limiting is indicated. Connect a scope probe to R40 (3.9 k) and adjust Peak Balance R33 until all peaks are of equal amplitude (twice input frequency).
- NOTE: Input level of -38dB should be sufficient for this adjustment.

7-2.6. POSITIVE THRESHOLD CHECK. Remove the negative peak limiting amplifier (IC 5) and adjust the Input signal for a reading of 5dB Peak Limiting. Turn the Positive Threshold (R37) CW and note the difference (increase) in Output level. This should be 2.0 to 2.2dB. Change R95 (at bracket behind front panel) if necessary.

7-2.7. OUTPUT METER CHECK. If R62 is in CCW position the Output level, indicating 0dB on the Output Meter should be +4dBm; in CW position the output level indicating 0dB should be +16dBm. A deviation of ± 0.5 dB is acceptable.

To avoid possible damage to the meter due to high output level, perform the following tests in the +16dBm position:

7-3. FUNCTIONAL TESTS.

7-3.1. RMS TRACKING AND LIMITING. Remove IC 5 and IC 6 and insert T4C. Apply a -20dB, 1 kHz signal to the input. Turn Input control CW until 5dB of RMS limiting is indicated. Adjust the Output level until the meter also reads -5dB.

Remove T4C. Both meters should indicate 0dB. A tracking error of 0.75dB at -5 limiting is acceptable.

NOTE: Tracking errors may be due to mismatch in T4C cells. This can be checked by removing the T4C and connecting pin #6 and #7 alternately through a 15 k resistor to ground. Both meters (RMS and Output) should indicate the same amount of limiting. If mismatch exists R8 may be changed to achieve tracking.

Replace T4C. Add 10dB input signal. The RMS Limiting meter must show 10dB more limiting. The Output must remain below -2dB.

Replace IC 5 and IC 6.

7-3.2. PEAK LIMITING. Remove T4C. Apply -20dB, 1 kHz input signal. Turn the Input control CW until 10dB of Peak limiting is indicated. Reduce input signal to -30dB. The Peak limiting should read -1 to 0dB. The Output Level should remain within ± 1 dB.

Turn Limiting control (R75) CW. Peak Limiting Meter must indicate -10dB (± 1 dB).

Adjust the input level for an indicated 5dB of Peak limiting. Note the output level. Increase the input level by 20dB. The output level should not increase more than 1dB. Replace T4C. (Compression ratio 20 : 1).

7-3.3. COMBINED LIMITING. Set input level for 5dB RMS limiting. Adjust Peak limiting to indicate 5dB of Peak limiting. Note Output level. Increase input level by 20dB. The output level should not change more than +0.3dB.

7-4. PERFORMANCE VERIFICATION.

7-4.1. GAIN AND MAXIMUM OUTPUT LEVEL. Apply -50dB input signal. Set the following controls CW: Output Meter, Input, Limiting, Output. The output should read $\leq +22\text{dBm}$.

7-4.2. FREQUENCY RESPONSE. Frequency response is measured without RMS or Peak reduction. The controls are set as in 7-4.1 and -50dB input level is applied. The response at 30 Hz and 15 kHz must be within +0, -0.5dB of 1 kHz reference level.

7-4.3. DISTORTION. Distortion without RMS or Peak reduction is measured at spot frequencies 30 Hz and 15 kHz. Apply -30dB input signal (1 kHz) and set the controls as follows: Input, Limiting CCW; Output CW. Advance Input CW until +24dB is measured at the output. Distortion of spot frequencies must be less than 0.5%.

Distortion with RMS and Peak Limiting: Advance input CW until 5dB RMS limiting is indicated. Turn Limiting control CW until Peak limiting also indicates 5dB. Adjust Output control for +24dBm and measure the distortion at 50 Hz and 15 kHz. Reading must be less than 3%.

7-4.4. THRESHOLD OF LIMITING.

Peak Limiting: Set controls as follows: Input, Limiting, Output = CW. Apply an input signal (1 kHz) and increase this level until the Peak Meter indicates 0.5dB of limiting. The input level necessary to achieve this condition should be less than -38dB.

RMS Limiting: Increase the level of the input signal until the RMS meter indicates 0.5dB of limiting. This should occur at less than -32dB input level.

A Peak limiting of -5dB or more should be indicated. Set the Peak Limiting control to indicate 0.5dB of limiting. The Output should be +30dBm; f1dB.

Measure the Output of IC 4. The reading should be 5 Vpp.

7-4.5. NOISE. Terminate the input with a 600 ohm dummy load, or turn the Input control CCW while no input signal is applied. (Limiting and Output = CW). Connect the terminated output through a filter with 15.7 kHz B.W. to a VTVM and read the noise level. This should be -40dB or less.

SECTION VIII

FIELD MODIFICATIONS

8-1. ASYMMETRY. The F.C.C. allows a maximum of 125% positive modulation. The BL-40 is designed to allow 125% overmodulation if the transmitter responds linearly to positive peaks. In some cases it may be desirable to achieve more than 125% positive peaks to compensate for modulator non-linearity. This may be accomplished by purposely misadjusting R33 the peak balance control. This should be done very carefully to avoid extreme imbalance as the control is very sensitive.

INTERKAL

8-2. TRANSFORMERLESS OUTPUT CONNECTION. In some installations it may be desired to bypass the output transformer. This may be done by taking the output signal from the monitor output. A 10dB reduction in gain will result. The monitor output source impedance is 600 ohms resistive.

8-3. ADJUSTING RELEASE TIME OF PEAK LIMITER. The release time of the peak limiter is adjusted for a good compromise between fastest possible release and minimum waveform distortion.

If some waveform distortion can be tolerated, the release time may be shortened, resulting in higher average modulation.

The 1 uF capacitor C35 may be reduced in value to .22 uF (minimum) to decrease both attack and release times. This will result in some audible distortion particularly on solo instrument passages.

8-4. RECALIBRATION OF OUTPUT METERING. Some transmitters will require more than +16dBm to achieve 100% modulation. In this case the output meter sensitivity may be decreased 10dB by replacing R63 with a 330 ohm resistor.

8-5. ADJUSTMENT OF PHASE OPTIMIZER SENSITIVITY. The Phase Optimizer is factory set to trigger on 1dB imbalance between positive and negative peaks. R108 on the Phase Optimizer board may be adjusted for more or less sensitivity. With R108 fully clockwise imbalance sensitivity is about 0.1dB and at full CCW about 10dB.

8-6. DEFEATING PHASE OPTIMIZER. If automatic polarity reversal is not desired, the BL-40 Phase Optimizer may be disabled by physically removing IC 11 from its socket on the Phase Optimizer board. In this configuration the output of the BL-40 will remain in phase with its input, and the LED indicator will remain GREEN.

SECTION IX

PARTS LIST BL-40

<u>Description of Part</u>	<u>Reference Designation</u>	<u>UREI Part Number or Equivalent</u>
Transformers	T1	B 11178
	T2	B 11184
	T3	B 11148
	T4	B 11588
Operational Amplifiers	IC 1-4	LM 301 A
	IC 7-12	LM 301 A
	IC 5	LM 318
	IC 6	LM 310 or LM 318
Transistors	Q1,4,16	FET U 2244
	Q2,6,10	U 05
	Q3,11	U 55
	Q5,7,13	86-5117-2
	Q8,9	2N 5087
	Q12	MJE 3055
	Q14	2N 3638
	Q15	MJE 2955
	Diodes	CR1,2,3,5,6
CR10,19		Silicon "violet" 86-5037-3
CR4		L.E.D. Red/Green MV 5491
CR7		Germanium 1N 90
CR8,9,11-17		Silicon 1N 4003
CR18		Silicon Zener 10V 1N 4740A
Optical Attenuator	T4C	T4C
Capacitors (Capacitor values are in "uF" unless otherwise specified.)	C1,2,42,43,55	.001 Ceramic
	C3,4,5,12,44,50,51,56,66	33 pF Ceramic
	C8	.47 Mylar
	C9,21,61,64	10 pF Ceramic
	C13,14,34,37,40	50 uF/25V Electrolytic
	C15	.0033 Mylar
	C16	80 uF/25V Electrolytic
	C18,20,35	1.0 Mylar
	C19	100 uF/6V Electrolytic
	C25,27	180 pF 5% Silver mica
	C26	100 pF 5% Silver mica
	C28	3.3 pF Ceramic
	C29,65	.01 Ceramic
	C30-33	.1 Ceramic
	C36,59,62,63	6.8 uF/35V Tantalum

<u>Description of Part</u>	<u>Reference Designation</u>	<u>UREI Part Number or Equivalent</u>	
Capacitors	C38	220 pF Mica	
	C39	12 pF Ceramic	
	C41	2000 uF/15V Electrolytic	
	C48,49	1000 uF/50V Electrolytic	
	C52,53	80 uF/25V Electrolytic	
	C57,58, 67,68	100 uF/25V Electrolytic	
	C54	.22 Mylar	
	C60	.1 Mylar	
	(All resistors are carbon 5% tolerance, ½ watt, unless otherwise specified.)	R1	47 Ohm
		R2	47 Ohm
R3		600 T Attenuator, type J	
R4		3.3 k Ohm	
R5		2.7 k Ohm	
R6		12 k Ohm	
R7		33 Ohm	
R8		25 K Pot flat mount	
R9		100 k Ohm	
R10		100 Ohm	
R11		15 k Ohm	
R12		10 K Pot upright mount	
R13		2.7 k Ohm	
R14		33 Ohm	
R15		1.6 k Ohm	
R16		220 k Ohm	
R17		150 k Ohm	
R18		120 k Ohm	
R19		220 Ohm	
R20		1 k Ohm	
R21		22 k Ohm	
R22		4.7 k Ohm	
R23		68 k Ohm	
R24		10 k Pot flat mount	
R25		100 k Ohm	
R26		330 k Ohm	
R27		330 Ohm	
R28		22 k Ohm	
R29		1 M Ohm	
R30		22 k Ohm	
R31		330 Ohm	
R32		1 M Ohm	
R33		100 k Pot flat mount	
R34		470 k Ohm	
R35		4.99 k Ohm 1%	

<u>Description of Part</u>	<u>Reference Designation</u>	<u>UREI Part Number or Equivalent</u>
Resistors	R36	4.99 k Ohm 1%
	R37	250 Ohm Pot upright mount
	R38	680 Ohm
	R39	1 k Ohm
	R40	3.9 k Ohm
	R41	39 Ohm
	R42	4.7 k Ohm
	R43	2.2 k Ohm
	R44	47 k Ohm
	R45	10 Ohm
	R46	100 k Ohm Pot audio taper type J
	R47	18 Ohm
	R48	47 k Ohm
	R49	3.3 k Ohm
	R50	100 k Ohm
	R51	68 k Ohm
	R52	10 k Ohm
	R53	39 k Ohm
	R54	22 k Ohm
	R55	1 k Ohm
	R56	10 k Ohm
	R57	100 Ohm
	R58	1.2 k Ohm
	R59	1.2 k Ohm
	R60	4.3 Ohm
	R61	4.3 Ohm
	R62	2.k Ohm Pot upright mount
	R63	1 k Ohm
	R64	3 k Ohm
	R65	3.6 k Ohm
	R66	10 k Ohm Pot upright mount
	R67	50 k Ohm Pot flat mount
	R68	220 k Ohm
	R69	13 k Ohm
	R70	100 k Ohm
	R71	620 Ohm
	R72	Not used
	R73	15 k Ohm
	R74	22 k Ohm
	R75	10 k Ohm linear taper, type J
	R76	100 k Ohm
	R77	1 k Ohm
	R78	4.7 k Ohm
	R79	10 k Ohm Pot upright mount
	R80	2.7 k Ohm
	R81	330 Ohm
	R82	4.7 k Ohm

<u>Description of Part</u>	<u>Reference Designation</u>	<u>UREI Part Number or Equivalent</u>
Resistors	R83	6.8 Ohm
	R84	2.2 k Ohm
	R85	10 k Ohm
	R86	10 k Ohm
	R87	2.2 k Ohm
	R88	6.8 Ohm
	R89	39.2 k Ohm 1%
	R90	39.2 k Ohm 1%
	R91	680 Ohm
	R92	15 k Ohm
	R93	2.2 k Ohm
	R94	3.3 k Ohm
	R95	Factory selected
	R96	10 Ohm
	R97	10 Ohm
	R98	Not used
	R99	Not used
	R100	100 k Ohm
	R101	10 k Ohm
	R102	100 k Ohm
	R103	180 k Ohm
R104	180 k Ohm	
R105	100 k Ohm	
R106	100 k Ohm	
R107	1 M Ohm	
R108	100 k Ohm Pot flat mount	
R109	10 k Ohm	
R110	10 k Ohm	
R111	10 M Ohm	
R112	10 k Ohm	
R113	1 k Ohm	
R114	33 Ohm	
R115	33 Ohm	
R116	100 k Ohm	
R117	470 k Ohm	

SECTION X

RECOMMENDED SPARES

The following recommended spare parts may be purchased from U.R.E.I. through your dealer, at a cost of approximately \$30. (Price may vary slightly to reflect current cost at time of purchase.)

Operational Amplifiers	:	2 ea.	LM 301 A	
	:	1 ea.	LM 318 A	
		1 ea.	LM 310 A	
Transistors	:	1 ea.	U 2244	
		1 ea.	MPS U 05	
		1 ea.	MPS U 55	
		1 ea.	86-5117-2	
		1 ea.	2N 5087	
		1 ea.	MJE 3055	
		1 ea.	MJE 2955	
		1 ea.	2N 3638	
Diodes	:	1 ea.	1N914 B (may be substituted for 86-5037-3)	
		1 ea.	1N 4740 A	

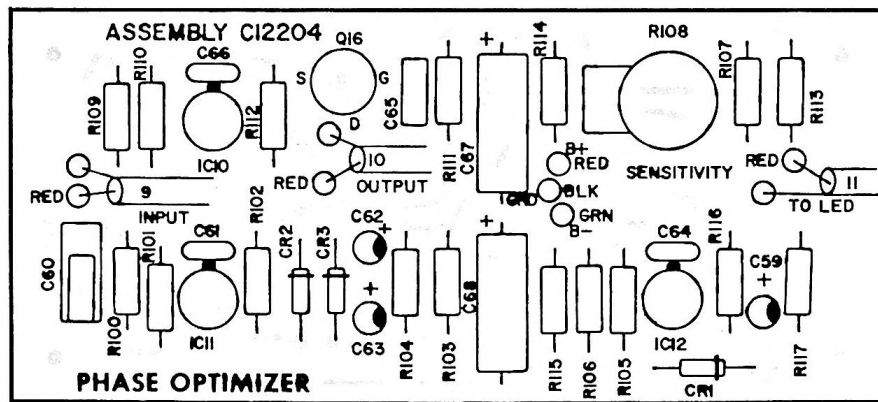

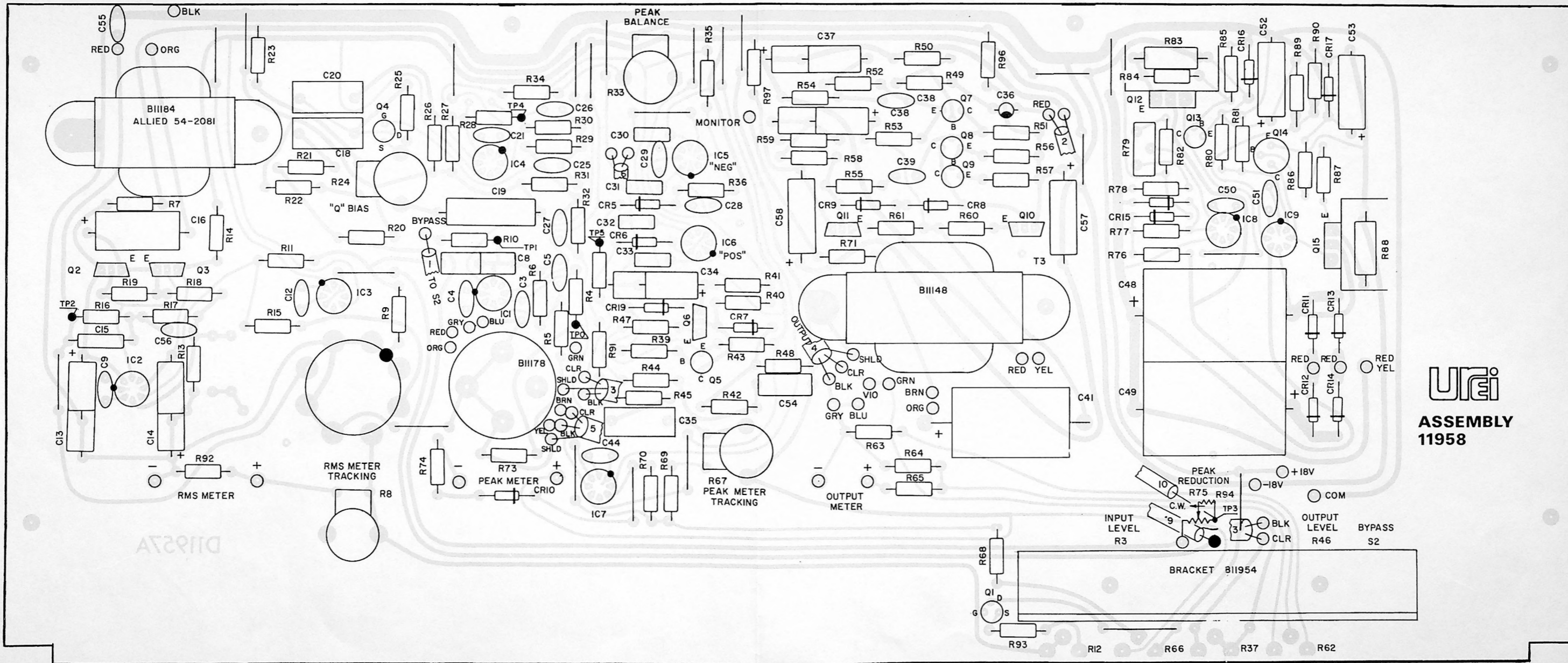

URi
ASSEMBLY
11958

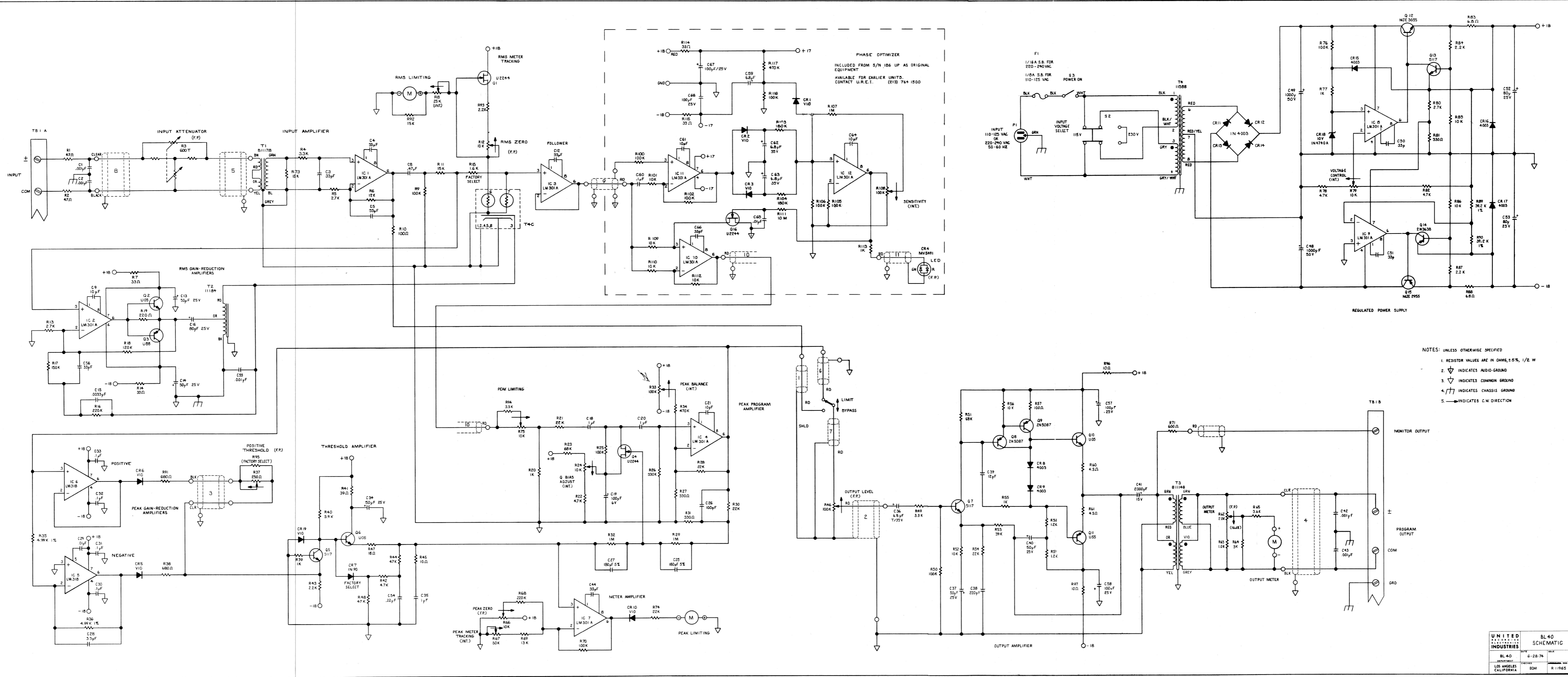

- NOTES: UNLESS OTHERWISE SPECIFIED
1. RESISTOR VALUES ARE IN OHMS, ±5%, 1/2 W
 2. ⏏ INDICATES AUDIO-GROUND
 3. ⏏ INDICATES COMMON GROUND
 4. ⏏ INDICATES CHASSIS GROUND
 5. → INDICATES C.W. DIRECTION